



Count on it.

Parts Catalog

Hand Spray Gun Kit

Multi-Pro® 5800 Turf Sprayer

Model No. 41605—Serial No. 313000001 and Up



Ordering Replacement Parts

To order replacement parts, please supply the part number, the quantity, and the description of each part desired.

Understanding Reference Numbers

Each identified part in an illustration has a reference number. The reference number for a part also appears in the parts list, along with other information about the part.

This catalog uses two special reference number formats, one to indicate parts in a service assembly and another to indicate the quantity of a given part in an illustration.

Service Assembly Reference Numbers

Parts in service assemblies have reference numbers in the form a:b. The a represents the reference number of the entire service assembly and the b represents a sequential number unique to each part within the service assembly.

For example, a wheel assembly might be identified by reference number 6, the tire by 6:1, the valve by 6:2, and the wheel by 6:3. When you order the assembly identified by reference number 6, you receive all parts identified by reference numbers 6:1, 6:2, and 6:3. However, you may also order any part individually. Reference numbers of this type appear in illustration and in parts lists.

Reference Numbers Indicating Quantity

In an illustration, if a reference number indicates more than one part, the reference number has the form nX y. The n represents the quantity of the part, the X is the multiplication symbol, and the y represents the reference number.

For example, in an illustration, the reference number 2X 37 means that two of the parts identified by reference number 37 are indicated.

List of Abbreviations

AR: as required	HLH: hex lag head	PTO: power-take-off
ASM: assembly	HOC: height-of-cut	RH: right hand
BBC: blade brake control	HSBH: hex socket button head	ROPS: roll-over protection system
BHTF: button head thread forming	HSFH: hex socket flat head	RRB: rear roller brush
CARR: carriage	HSH: hex socket head	SFH: slotted fillister head
CCW: counter clockwise	HWH: hex washer head	SHH: slotted hex head
CW: clockwise	HWHTF: hex washer head thread forming	SHWH: slotted hex washer head
DEG: degrees	HYD: hydraulic	SPH: slotted pan head
DPA: Dual Point Adjustment	LH: left hand	SQH: square head
ECM: electronic control module	LP: Liquefied Petroleum Gas	SRH: slotted round head
EXT: external	LPG: Liquefied Petroleum Gas	STD: standard
FH: flat head	NI: nylon insert	TAP: self tapping
GA: gauge	NPTF: national pipe thread fine	TTH: torx truss head
HD: heavy-duty	PFH: phillips flat head	
HF: hex flange	PPH: phillips pan head	
HH: hex head	PPHTF: phillips pan head thread forming	
HHF: hex head flange	PRH: phillips round head	
HHFTF: hex head flange thread forming	PTH: phillips truss head	
HJ: hex jam		

Contents

Hand Spray Gun Kit 4
Spray Gun Assembly No. 120-8610 6

Hand Spray Gun Kit

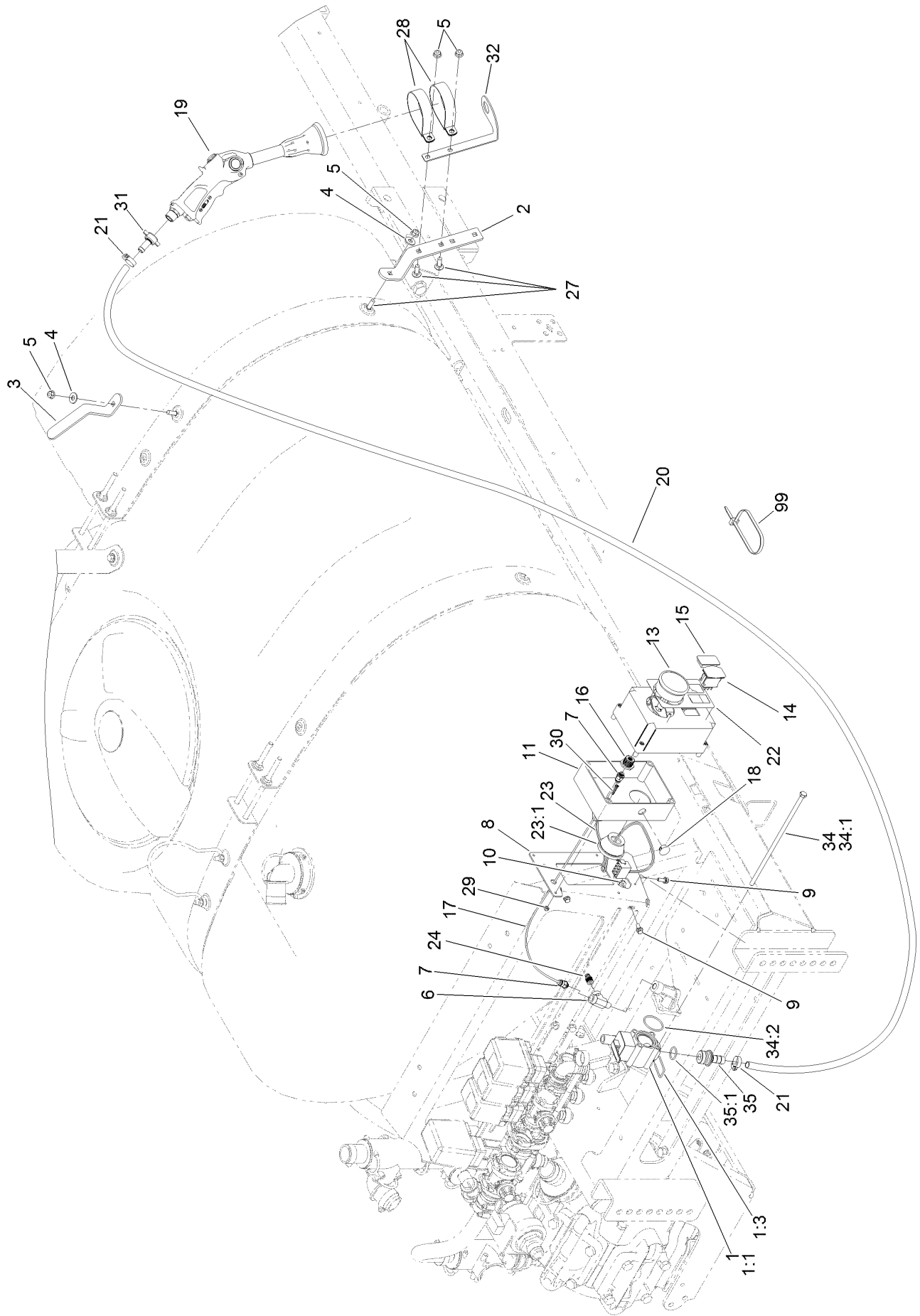

Hand Spray Gun Kit (continued)

<i>Ref.</i>	<i>Part Number</i>	<i>Qty.</i>	<i>Description</i>	<i>Ref.</i>	<i>Part Number</i>	<i>Qty.</i>	<i>Description</i>
1		1	Manual Valve ASM ●	19	120-8610	1	Spray Gun ASM
1:1	119-4935	1	Valve-Manual	20	107-8751	1	Hose-Spray Gun
1:3	119-4901	1	Fork	21	2412-36	2	Clamp-Hose
2	121-4986-03	1	Bracket-Spraygun	22	120-0686	1	Decal-Spray Gun
3	40153-03	1	Hook-Hose	23	119-5788	1	Harness-Wire, Spray Gun
4	3256-3	2	Washer-Flat	23:1	32180-033	1	Grommet
5	104-8300	4	Nut-Flange, NI	24	100-8674	1	Coupler-Tube
6	2815-16	1	Fitting-HYD, Tee	27	3230-2	4	Bolt-CARR
7	100-8667	1	Coupler-Reducer	28	120-8592	2	Clamp-R
8	120-8591-03	1	Mount-Control	29	3296-1	4	Nut-Lock
9	3234-33	3	Screw-HHF	30	363-3160	4	Screw-Ssh
10	32128-33	3	Nut-HF	31	121-4982	1	Hosebarb-Spray Gun
11	120-8590	1	Box-Control	32	120-8593-03	1	Bracket-Spray Gun
13	120-8546	1	Gauge-Pressure	34		1	Bracket-Mounting Kit ●
14	100-1535	1	Switch	34:1	119-4880	4	Screw-HH
15	99-7420	1	Plug-Hole	34:2	119-4974	1	O-Ring
16	100-8665	1	Reducer-Gauge, Pressure	35	120-0682	1	Hosebarb
17	119-4954	1	Gauge-Pressure, Tube	35:1	119-4975	1	O-Ring
18	94-5627	1	Plug	99	3290-379	2	Tie-Cable

● Not serviced separately

Spray Gun Assembly No. 120-8610

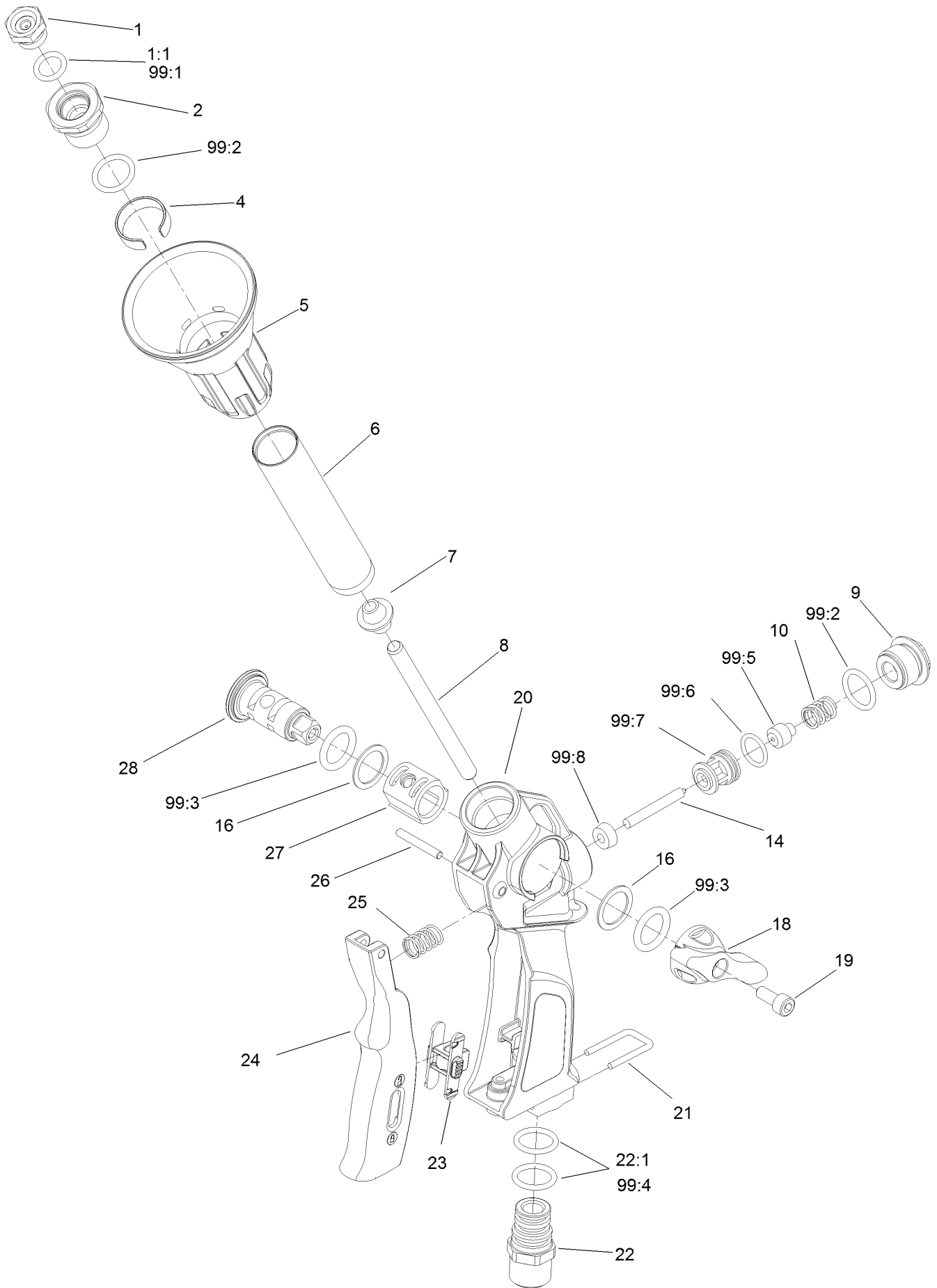

Spray Gun Assembly No. 120-8610 (continued)

<i>Ref.</i>	<i>Part Number</i>	<i>Qty.</i>	<i>Description</i>	<i>Ref.</i>	<i>Part Number</i>	<i>Qty.</i>	<i>Description</i>
1	121-4950	1	Nozzle-2.3Mm	22:1	121-4972	2	O-Ring
1:1	121-4951	1	O-Ring	23	121-4974	1	Slide-Lever
2	121-4952	1	Head-Nozzle Holder	24	121-4975	1	Lever-Spraygun
4	121-4954	1	Ring-Spacer	25	121-4977	1	Spring
5	121-4955	1	Spreader-Micro Jet	26	121-4978	1	Pin-Lever
6	121-4956	1	Tube-Spray Gun	27	121-4979	1	Cover-Drum
7	121-4957	1	Conveyor-Inner	28	121-4980	1	Drum-Regulation
8	121-4958	1	Tube-Spray Gun, Inner	99	121-4981	1	Spray Gun Seal Kit ●
9	121-4959	1	Drum-Regulation	99:1	121-4951	1	O-Ring
10	121-4960	1	Spring-Spray Gun	99:2	121-4953	2	Gasket
14	121-4964	1	Pin-Hinge	99:3	121-4967	2	O-Ring
16	121-4966	2	Washer-Teflon	99:4	121-4972	2	O-Ring
18	121-4968	1	Lever-Drum, Spray Gun	99:5	121-4962	1	Plunger-Cone
19	121-4969	1	Screw	99:6	121-4961	1	O-Ring
20	121-4970	1	Grip-Spray Gun	99:7	121-4963	1	Box And Seat
21	121-4971	1	Fork	99:8	121-4965	1	Seal
22	121-4973	1	Hose-Tail				

● Not illustrated



Count on it.