



Count on it.

Operator's Manual

Workman® MDE Utility Vehicle

Model No. 07299—Serial No. 31200001 and Up

Model No. 07299TC—Serial No. 31200001 and Up

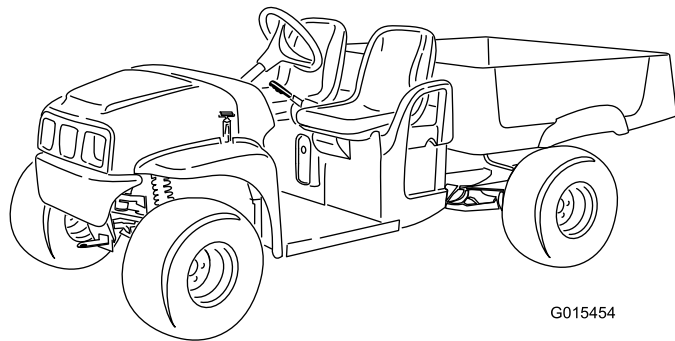

G015454



This machine is a utility vehicle intended to be used by professional, hired operators in commercial applications. It is primarily designed for the transport of implements used in such applications. This vehicle allows for the safe transport of an operator and one passenger in the identified seats. The bed of this vehicle is not suitable for any riders.

This product complies with all relevant European directives, for details please see the separate product specific Declaration of Conformity (DOC) sheet.

Introduction

Read this information carefully to learn how to operate and maintain your product properly and to avoid injury and product damage. You are responsible for operating the product properly and safely.

You may contact Toro directly at www.Toro.com for product and accessory information, help finding a dealer, or to register your product.

Whenever you need service, genuine Toro parts, or additional information, contact an Authorized Service Dealer or Toro Customer Service and have the model and serial numbers of your product ready. Figure 1 identifies the location of the model and serial numbers on the product. Write the numbers in the space provided.

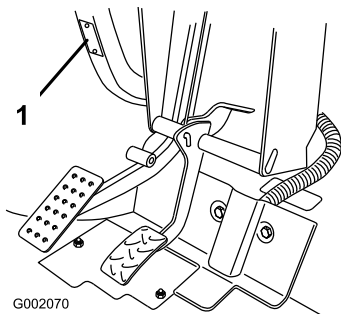

Figure 1

1. Model and serial number location

Model No. _____
Serial No. _____

This manual identifies potential hazards and has safety messages identified by the safety alert symbol (Figure 2), which signals a hazard that may cause serious injury or death if you do not follow the recommended precautions.



Figure 2

1. Safety alert symbol

This manual uses 2 other words to highlight information. **Important** calls attention to special mechanical information and **Note** emphasizes general information worthy of special attention.

Contents

Introduction.....	2	Replacing the Headlights	30
Safety	4	Drive System Maintenance	31
Safe Operating Practices	4	Inspecting the Tires	31
Before Operating	4	Adjusting Front Wheel Toe-In and	
Operation.....	4	Camber	31
Handling and Servicing Batteries.....	7	Checking the Transaxle Oil Level	33
Maintenance.....	8	Brake Maintenance	33
Sound Pressure.....	8	Inspecting the Brakes	33
Hand-Arm Vibration.....	8	Checking the Brake Fluid Level.....	33
Whole Body Vibration.....	8	Adjusting the Parking Brake.....	34
Safety and Instructional Decals	9	Cleaning.....	34
Setup	12	Washing the Vehicle.....	34
1 Installing the Steering Wheel	12	Storage	35
2 Installing the Batteries.....	12	Troubleshooting.....	36
3 Checking the Tire Pressure.....	14	Schematics	37
4 Setting the Charger Voltage (07299TC			
only).....	14		
5 Reading the Manual and Viewing the Safety			
Video	15		
Product Overview	16		
Controls	16		
Specifications	19		
Attachments/Accessories.....	19		
Operation.....	20		
Think Safety First.....	20		
Pre-Starting Checks	20		
Checking the Tire Pressure	20		
Operating the Vehicle	20		
Stopping the Vehicle.....	20		
Parking the Vehicle	20		
Understanding and Using the Battery			
System.....	20		
Operating the Cargo Box.....	22		
Breaking in a New Vehicle	23		
Loading the Cargo Box.....	23		
Transporting the Vehicle.....	23		
Towing the Vehicle	24		
Towing a Trailer.....	24		
Maintenance.....	25		
Recommended Maintenance Schedule(s)	25		
Daily Maintenance Checklist.....	25		
Pre-maintenance Procedures.....	26		
Maintaining the Vehicle under Special			
Operating Conditions	26		
Jacking the Vehicle.....	26		
Accessing the Hood.....	26		
Lubrication.....	27		
Adding Grease	27		
Electrical System Maintenance.....	28		
Maintaining the Batteries	28		
Replacing the Fuses	30		

Safety

Improper use or maintenance by the operator or owner can result in injury. To reduce the potential for injury, comply with these safety instructions and always pay attention to the safety alert symbol, which means **Caution**, **Warning**, or **Danger**—“personal safety instruction.” Failure to comply with the instruction may result in personal injury or death.

Supervisors, operators, and service persons should be familiar with the following standards and publications (the material may be obtained from the address shown):

SAE J2258 Light Utility Vehicle

SAE International, 400 Commonwealth Drive,
Warrendale, PA 15096-0001 U.S.A.

Safe Operating Practices

⚠ WARNING

The Workman is an off-highway vehicle only and is not designed, equipped, or manufactured for use on public streets, roads, or highways.

Supervisor's Responsibilities

- Make sure that operators are thoroughly trained and familiar with the *Operator's Manual* and all labels on the vehicle.
- Be sure to establish your own special procedures and work rules for unusual operating conditions (e.g. slopes too steep for vehicle operation).

Note: This vehicle has a supervisor speed limit switch to allow you to limit the maximum speed that the operator can drive the vehicle. Refer to Supervisor Speed Limit Switch section in Product Overview.

Before Operating

- Operate the vehicle only after reading and understanding the contents of this manual.
- Never allow children to operate the vehicle. Anyone who operates the vehicle should have a motor vehicle license.
- Never allow other adults to operate the vehicle without first reading and understanding the *Operator's Manual*. Only trained and authorized persons should operate this vehicle. Make sure that all operators are physically and mentally capable of operating the vehicle.
- This vehicle is designed to carry only you, the operator, and one passenger in the seat provided by

the manufacturer. Never carry any other passengers on the vehicle.

- Never operate the vehicle when under the influence of drugs or alcohol. Even prescription drugs and cold medicines can cause drowsiness.
- Do not drive the vehicle when you are tired. Be sure to take occasional breaks. It is very important that you stay alert at all times.
- Become familiar with the controls and know how to stop the vehicle quickly.
- Keep all shields, safety devices, and decals in place. If a shield, safety device, or decal is malfunctioning, illegible, or damaged, repair or replace it before operating the vehicle.
- Always wear substantial shoes. Do not operate the vehicle while wearing sandals, tennis shoes or sneakers. Do not wear loose fitting clothing or jewelry which could get caught in moving parts and cause personal injury.
- Wearing safety glasses, safety shoes, long pants and a helmet is advisable and required by some local safety and insurance regulations.
- Avoid driving when it is dark, especially in unfamiliar areas. If you must drive when it is dark, be sure to drive cautiously, use the headlights, and even consider adding additional lights.
- Be extremely careful when operating around people. Always be aware of where bystanders might be.
- Before operating the vehicle, always check the designated areas of the vehicle that are stated in the pre-starting section of this manual. If something is wrong, do not use the vehicle. Make sure that the problem is corrected before the vehicle or attachment is operated.

Operation

- The operator and passenger should remain seated whenever the vehicle is in motion. The operator should keep both hands on the steering wheel whenever possible, and the passenger should use the hand holds provided. Keep your arms and legs within the vehicle body at all times.
- Drive slower and turn less sharply when you are carrying a passenger. Remember your passenger may not be expecting you to brake or turn and may not be ready.
- Always watch out for and avoid low overhangs such as tree limbs, door jambs, and over-head walkways. Make sure there is enough room over head to easily clear the vehicle and your head.

- Failure to operate the vehicle safely may result in an accident, tip over of the vehicle, and serious injury or death. Drive carefully. To prevent tipping or loss of control:
 - Use extreme caution, reduce speed, and maintain a safe distance around sand traps, ditches, creeks, ramps, unfamiliar areas, or any areas that have abrupt changes in ground conditions or elevation.
 - Watch for holes or other hidden hazards.
 - Use extra caution when operating the vehicle on wet surfaces, in adverse weather conditions, at higher speeds, or with a full load. Stopping time and distance will increase with a full load.
 - Avoid sudden stops and starts. Do not go from reverse to forward or forward to reverse without first coming to a complete stop.
 - Slow down before turning. Do not attempt sharp turns or abrupt maneuvers or other unsafe driving actions that may cause a loss of vehicle control.
 - When dumping, do not let anyone stand behind the vehicle and do not dump the load on anyone's feet. Release the tailgate latches from the side of the box, not from behind.
 - Only operate the vehicle when the cargo box is down and latched.
 - Before backing up, look to the rear and ensure that no one is behind you. Back up slowly.
 - Watch out for traffic when you are near or crossing roads. Always yield the right of way to pedestrians and other vehicles. This vehicle is not designed for use on streets or highways. Always signal your turns or stop early enough so that other people know what you plan to do. Obey all traffic rules and regulations.
 - The electrical system of the vehicle can produce sparks capable of igniting explosive materials. Never operate the vehicle in or near an area where there is dust or fumes in the air which are explosive.
 - If you are ever unsure about safe operation, stop work and ask your supervisor.
- If the vehicle ever vibrates abnormally, stop immediately, wait for all motion to stop, and inspect the vehicle for damage. Repair all damage before commencing operation.
- Before getting off of the seat:
 1. Stop the movement of the vehicle.

2. Set the parking brake.
3. Turn the key to Off.
4. Remove the key.

Note: If the vehicle is on an incline, block the wheels after getting off of the vehicle.

5. Lightning can cause severe injury or death. If lightning is seen or thunder is heard in the area, do not operate the machine; seek shelter.

Braking

- Slow down before you approach an obstacle. This gives you extra time to stop or turn away. Hitting an obstacle can damage the vehicle and its contents. More important, it can injure you and your passenger.
- Gross Vehicle Weight (GVW) has a major impact on your ability to stop and/or turn. Heavy loads and attachments make a vehicle harder to stop or turn. The heavier the load, the longer it takes to stop.
- Decrease the vehicle speed if the cargo box has been removed and there is no attachment on the vehicle. The braking characteristics change and fast stops may cause the rear wheels to lock up, which may affect the control of the vehicle.
- Turf and pavement are much more slippery when they are wet. It can take 2 to 4 times as long to stop on wet surfaces as on dry surfaces. If you drive through standing water deep enough to get the brakes wet, they will not work well until they are dry. After driving through water, you should test the brakes to make sure they work properly. If they do not, drive slowly while putting light pressure on the brake pedal. This will dry the brakes out.

Operating on Hills

⚠ WARNING

Operating the vehicle on a hill may cause tipping or rolling of the vehicle, or the batteries may run low and you could lose headway on the hill. This could result in personal injury.

- Do not operate machine on excessively steep slopes.
- Do not accelerate quickly or slam on the brakes when backing down a hill, especially with a load.
- If the batteries run low or you begin to lose headway while climbing a hill, gradually apply the brakes and slowly back straight down the hill.
- Operate the vehicle slowly on a hill and use caution.
- Avoid turning on a hill.
- Reduce your load and the speed of the vehicle.
- Avoid stopping on hills, especially with a load.

These extra cautions need to be taken when operating the vehicle on a hill:

- Slow down before starting up or down a hill.
- If the batteries run low or you begin to lose headway while climbing a hill, gradually apply the brakes and slowly back straight down the hill.
- Turning while traveling up or down hills can be dangerous. If you have to turn while on a hill, do it slowly and cautiously. Never make sharp or fast turns.
- Heavy loads affect stability. Reduce the weight of the load and your speed when operating on hills or if the load has a high center of gravity. Secure the load to prevent it from shifting and take extra care when hauling loads that shift easily (liquid, rock, sand, etc.).
- Avoid stopping on hills, especially with a load. Stopping while going down a hill will take longer than stopping on level ground. If the vehicle must be stopped, avoid sudden speed changes, which may initiate tipping or rolling of the vehicle. Do not slam on the brakes when rolling backward, as this may cause the vehicle to overturn.
- You can install an optional ROPS kit for operation in hilly terrain.

Operating on Rough Terrain

Reduce speed and load when operating on rough terrain, uneven ground, and near curbs, holes, and other sudden

changes in terrain. Loads may shift, causing the vehicle to become unstable.

You can install an optional ROPS kit for operation in rough terrain.

⚠ WARNING

Sudden changes in terrain may cause abrupt steering wheel movement, possibly resulting in hand and arm injuries.

- Reduce your speed when operating on rough terrain and near curbs.
- Grip the steering wheel loosely around the perimeter keeping thumbs up and out of the way of the steering wheel spokes.

Loading and Dumping

The weight and position of the cargo and passenger can change the vehicle center of gravity and vehicle handling. To avoid loss of control and personal injury, follow these guidelines:

- Do not carry loads which exceed the load limits described on the vehicle weight label; refer to Specifications in the Product Overview section, for vehicle weight limits. The load rating is for level surfaces only.
- Reduce the weight of the load when operating on hills and rough terrain to avoid tipping or overturning of the vehicle.
- Reduce the weight of the load if the center of gravity is high. Items such as bricks, fertilizer, or landscape timbers stack higher in the box. The higher a load is stacked, the more likely the vehicle is to tip over. Distribute the load as low as possible, making sure that the load does not affect rear visibility.
- Position the weight of the load evenly from side to side. If you position the load toward one of the sides, the vehicle is more likely to tip over while turning.
- Position the weight of a load evenly from front to back. If you position the load behind the rear axle, it will reduce the weight on the front wheels. This may result in a loss of steering control or cause the vehicle to tip over on hills or bumpy terrain.
- Use extra caution if the load exceeds the dimensions of the box and when handling off-center loads that cannot be centered. Keep loads balanced and secure to prevent them from shifting.
- Always secure loads so that they do not shift. If a load is not secured, or you are transporting a liquid in a large container such as a sprayer, the load can shift. This shifting happens most often while turning,

going up or down hills, suddenly changing speeds, or while driving over rough surfaces. Shifting loads can cause the vehicle to tip over.

⚠ WARNING

The weight of the box may be heavy. Hands or other body parts could be crushed.

- **Keep hands and other body parts clear when lowering the box.**
- **Do not dump materials on bystanders.**
- Never dump a loaded cargo box while the vehicle is sideways on a hill. The change in weight distribution may cause the vehicle to overturn.
- When operating with a heavy load in the cargo box, reduce your speed and allow for sufficient braking distance. Do not suddenly apply the brakes. Use extra caution on slopes.
- Be aware that heavy loads increase your stopping distance and reduce your ability to turn quickly without tipping over.
- The rear cargo space is intended for load carrying purposes only, not for passengers.
- Never overload your vehicle. The decal (located on the rear frame) shows load limits for the vehicle. Never overload the attachments or exceed the Gross Vehicle Weight (GVW).

Handling and Servicing Batteries

- To reduce the potential for fire, keep the batteries and motor area free of excessive grease, grass, leaves, and accumulation of dirt.
- Always disconnect and remove a battery cable before servicing any electrical components.
- Disconnecting any battery cable will inhibit operation of the electrical system.
- Battery electrolyte contains sulfuric acid. Sulfuric acid produces hydrogen gas which, in the right proportions is explosive.
 - Always service, store, and charge the vehicle in a well ventilated area.
 - Keep sparks and open flames away from the batteries.
 - Do not smoke near the batteries.
 - Never use an open flame to check the level or leakage of battery electrolyte.
- Use caution when handling and working around electrolyte. The sulfuric acid in electrolyte can burn

skin and damage clothing. Furthermore, it can be emitted as a gas that can damage your lungs.

- Wear proper eye, hand, and face protection.
- Do not lean over the batteries at any time.
- Avoid breathing battery fumes.
- Fill the batteries where clean water is always available for flushing the skin.
- If you get electrolyte on your skin or eyes, flush the affected area for 20 minutes with clean water. Remove acid soaked clothing . Seek medical attention immediately.
- Keep children and pets away from the batteries and electrolyte.
- Electrolyte is very poisonous.
 - Do not drink electrolyte.
 - If electrolyte is swallowed, do not induce vomiting; instead, drink large amounts of water or milk followed by milk of magnesia, beaten raw eggs, or vegetable oil. Get medical attention immediately.
 - Keep children and pets away from the batteries and electrolyte.
- When not filling the batteries, keep the battery vent caps tight on the batteries. Never operate the vehicle if any of the vent caps are missing or damaged.
- When removing or installing the batteries, do not allow the battery terminals to touch any metal parts of the vehicle.
- Do not allow metal tools to short between the battery terminals and metal parts of the vehicle. Remove all jewelry and watches before servicing the batteries.
- Do not check a battery charge by placing a metal object across the posts. This will cause sparks which can cause an explosion.
- Always keep the battery retainers in place to protect and secure the batteries.
- Read and understand the charging instructions before charging the batteries; refer to Charging the Batteries in Maintenance (page 25). Also, take the following precautions and actions when charging the batteries:
 - Turn the vehicle On/Off switch to Off before connecting the charger to a power source.
 - Use only the battery charger supplied with the vehicle to charge the batteries.
 - Do not charge a damaged or frozen battery.
 - Always unplug the AC power cord from the power outlet before unplugging it from the vehicle charging receptacle to avoid sparks.

- If during charging a battery gets hot, begins emitting large amounts of gasses, or spews electrolyte, immediately disconnect the charger power cord from the power outlet. Have the vehicle serviced by an Authorized Service Dealer before using it again.

Uncertainty Value (K) = 0.5 m/s²

Measured values were determined according to the procedures outlined in EN 1032.

Maintenance

- Only qualified and authorized personnel shall be permitted to maintain, repair, adjust, or inspect the vehicle.
- Before servicing or making adjustments to the vehicle, stop the vehicle, set the parking brake, and remove the key to prevent someone from accidentally starting the motor.
- To make sure that the entire vehicle is in good condition, keep all nuts, bolts, and screws properly tightened.
- Do not use open pans of fuel or flammable cleaning fluids for cleaning parts.
- If major repairs are ever needed or assistance is required, contact an Authorized Toro Distributor.
- To be sure of optimum performance and safety, always purchase genuine Toro replacement parts and accessories. Replacement parts and accessories made by other manufacturers could be dangerous. Altering this vehicle in any manner that may affect vehicle operation, performance, durability, or its use, may result in injury or death. Such use could void the product warranty.

Sound Pressure

This unit has a sound pressure level at the operator's ear of 68 dBA, which includes the Uncertainty Value (K) of 1 dBA.

Hand-Arm Vibration

Measured vibration level for right hand = 0.43 m/s²

Measured vibration level for left hand = 0.38 m/s²

Uncertainty Value (K) = 0.5 m/s²

Measured values were determined according to the procedures outlined in EN 1032.

Whole Body Vibration

Measured vibration level = 0.2 m/s²

Safety and Instructional Decals



Safety decals and instructions are easily visible to the operator and are located near any area of potential danger. Replace any decal that is damaged or lost.

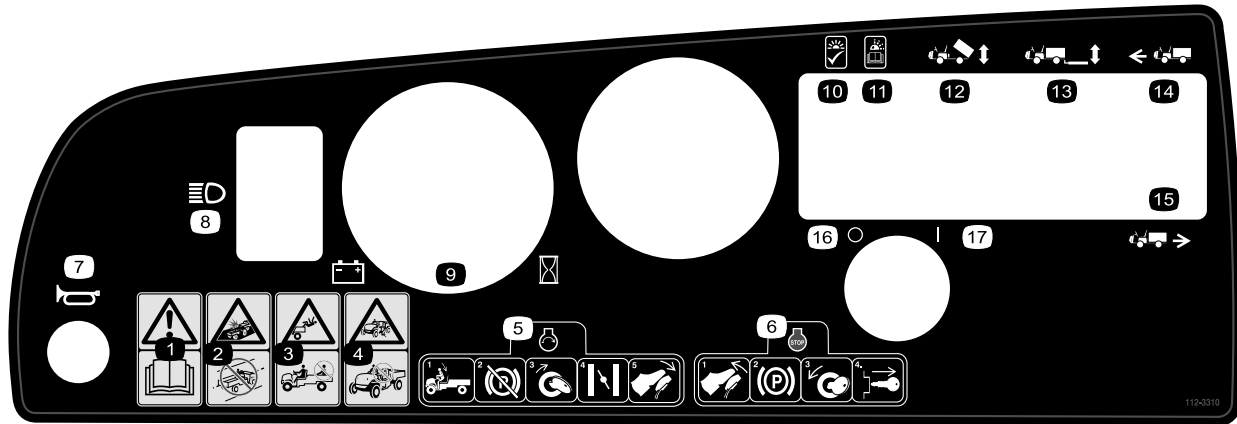

112-3310

- | | |
|---|---|
| 1. Warning—read the <i>Operator's Manual</i> . | 10. Light on, OK |
| 2. Collision hazard—do not operate the vehicle on public streets, roads, or highways. | 11. Light blinking, read the <i>Operator's Manual</i> . |
| 3. Falling hazard—do not carry passengers in the cargo bed. | 12. Cargo bed lift |
| 4. Falling hazard—do not allow children to operate the vehicle. | 13. Rear lift |
| 5. To start the motor, sit on the operator's seat, release the parking brake, turn the power key on, pull the choke lever out (if needed), and press the accelerator pedal. | 14. Forward |
| 6. To stop the motor, release the accelerator pedal, set the parking brake, turn the power key off, and remove the power key. | 15. Reverse |
| 7. Horn | 16. Power—Off |
| 8. Headlights | 17. Power—On |
| 9. Battery/hour meter | |



104-7215

1. Warning—read the *Operator's Manual*.
2. Explosion hazard—no fire, open flames, or smoking around batteries.
3. Warning—do not operate this machine unless you are trained.
4. Tipping hazard—use caution and drive slowly while on slopes; drive slowly when turning, keep the vehicle speed under 16 MPH (26 km/h) when carrying a full or heavy load and when driving on rough terrain.
5. Falling and arm/leg injury hazards—do not carry passengers in the cargo bed and keep arms and legs inside of the vehicle at all times.



104-7207

1. Poison hazard—read the *Operator's Manual*.
2. Explosion hazard—no fire, open flames, or smoking.
3. Caustic liquid/chemical burn hazard—to perform first aid, flush with water.

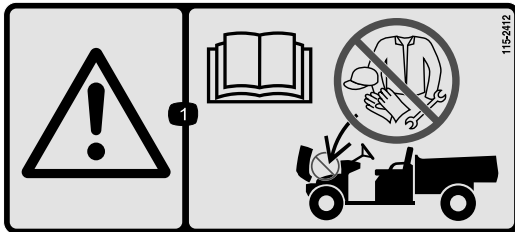

115-2412

1. Warning—read the *Operator's Manual*; no storage.

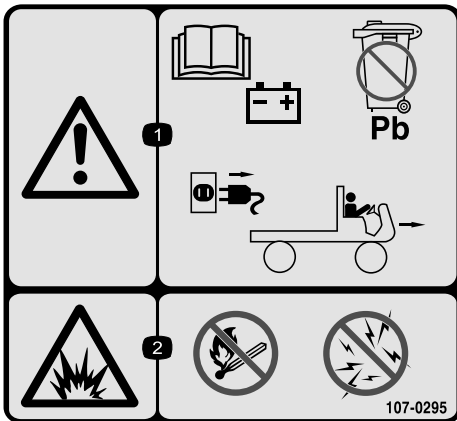

107-0295

1. Warning—read the *Operator's Manual* for more information on batteries; batteries contain lead, do not discard; disconnect the power cord from power source before driving vehicle.
2. Explosion hazard—no fire, open flames, or smoking; avoid sparks.

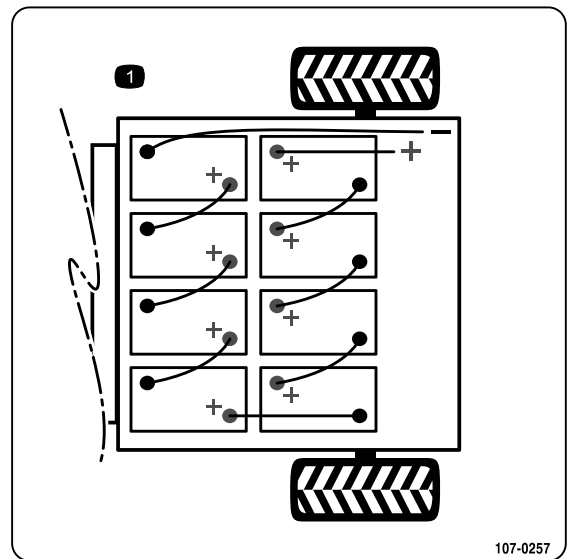

107-0257

1. Battery schematic



107-0356

1. Warning—do not touch moving objects, fan; do not touch the hot surfaces; read the *Operator's Manual*.



99-7954

1. Warning—read the *Operator's Manual*.
2. Falling hazard—do not carry passengers in the cargo bed.
3. Explosion hazard, static discharge into fuel container—do not fill fuel containers in the cargo bed; place fuel containers on the ground before filling.

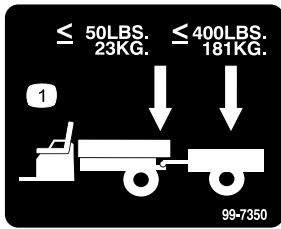

99-7350

1. Maximum tongue weight is 50 lb (23 kg); maximum trailer weight is 400 lb (181 kg).

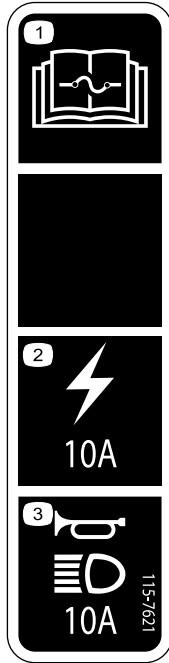

115-7621

1. Read the *Operator's Manual* for information on fuses.
2. 10 amp fuse for the power point.
3. 10 amp fuse for the horn and headlights.



Battery Symbols

Some or all of these symbols are on your battery

- | | |
|--|--|
| 1. Explosion hazard | 6. Keep bystanders a safe distance from the battery. |
| 2. No fire, open flame, or smoking. | 7. Wear eye protection; explosive gases can cause blindness and other injuries |
| 3. Caustic liquid/chemical burn hazard | 8. Battery acid can cause blindness or severe burns. |
| 4. Wear eye protection | 9. Flush eyes immediately with water and get medical help fast. |
| 5. Read the <i>Operator's Manual</i> . | 10. Contains lead; do not discard. |

Setup

Loose Parts

Use the chart below to verify that all parts have been shipped.

Procedure	Description	Qty.	Use
1	Steering wheel	1	Install the steering wheel (Model 07299TC only).
2	Battery hold down Battery hold down rod Battery cables Battery tray pads Battery pad Flange nut (3/8 inch) Battery terminal protector spray	2 2 7 4 1 2 1	Install the batteries (Model 07299TC only).
3	No parts required	–	Check the tire pressure.
4	No parts required	–	Set the charger voltage (Model 07299TC only).
5	Operator's Manual Parts Catalog Safety Training material Registration Card Predelivery Inspection Form Certificate of Quality Key	1 1 1 1 1 1 2	Read the Operator's Manual and view the training material before operating the machine.

Note: Determine the left and right sides of the machine from the normal operating position.



Installing the Steering Wheel

Parts needed for this procedure:

1	Steering wheel
---	----------------

Procedure

Note: This procedure is only needed for Model No. 07299TC.

1. Release the tabs on the back of the steering wheel that hold the center cover in place. Remove the cover
2. Remove the nut and washer from the steering shaft.
3. Slide the steering wheel and washer onto the shaft. Position the steering wheel on the shaft so that the cross beam is horizontal when the tires are pointed

straight ahead and the thicker spoke of the steering wheel is downward.

4. Secure the steering wheel to the shaft with the nut (Figure 3). Torque the nut to 18-22 ft-lb (24-29 N-m)

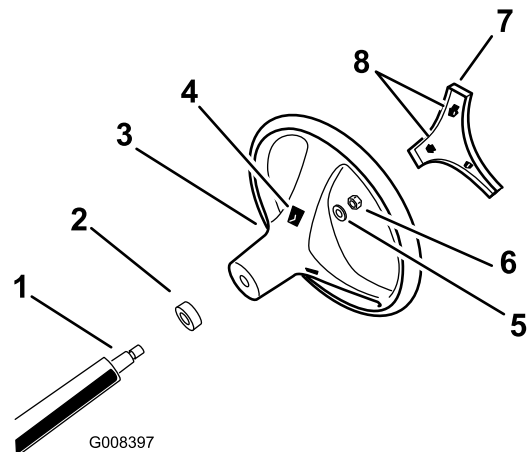

Figure 3

- | | |
|-----------------------|------------------|
| 1. Steering shaft | 5. Washer |
| 2. Foam seal | 6. Nut |
| 3. Steering wheel | 7. Cover |
| 4. Tab slots in wheel | 8. Tabs in cover |

5. Snap the center cover in place.

2

Installing the Batteries

Parts needed for this procedure:

2	Battery hold down
2	Battery hold down rod
7	Battery cables
4	Battery tray pads
1	Battery pad
2	Flange nut (3/8 inch)
1	Battery terminal protector spray

Procedure

Toro recommends the use of either Trojan T105 or T145, or US Battery US2200 or US145.

Battery Specification: 6V 225AH @ 20hr rate
 Dimensions: (LxWxH) (10-3/8 x 7-1/8 x 10-7/16 inches)

1. Turn the key switch to the Off position and remove the key.
2. Install the battery tray pads into the rear frame assembly as shown Figure 4.

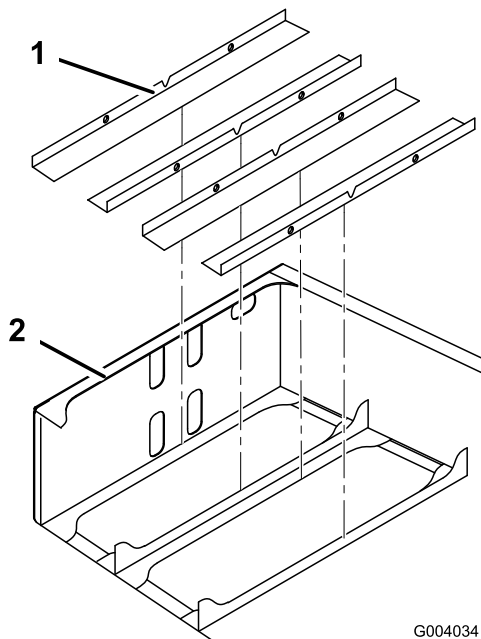

Figure 4

1. Battery tray pads
2. Rear frame assembly

3. Remove the adhesive strip from the back of the battery pad and install it to the front inside face of the rear frame as shown in Figure 5.

Note: The pad should be approximately 1/4 inch below the bottom edge of the upper set of cut-out holes (Figure 5).

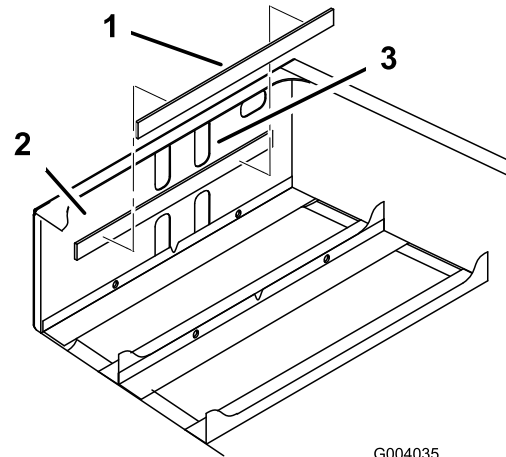

Figure 5

1. Battery pad
2. Front inside face
3. Upper cut-out holes

4. Install the batteries as shown in Figure 6.

Note: Pay attention to the battery polarity when installing the new batteries (Figure 6).

⚠ WARNING

Incorrect battery cable routing could damage the vehicle and cables causing sparks. Sparks can cause the battery gasses to explode, resulting in personal injury.

Always ensure the battery polarity when making connections.

⚠ CAUTION

Batteries can give you a powerful electrical shock.

- Use tools with plastic handles or wrap the handles of metal tools with electrical tape.
- Be careful not to contact both a positive terminal and a negative terminal at the same time.

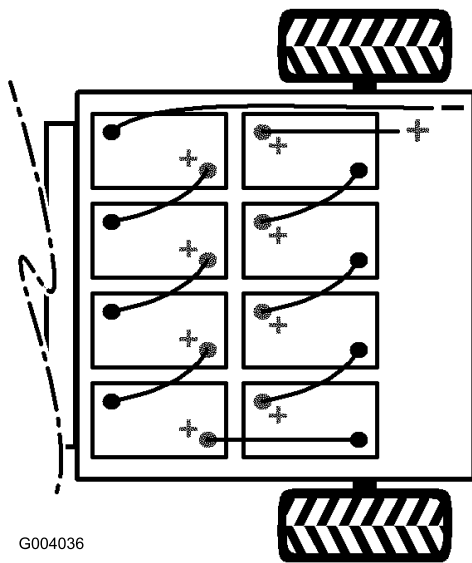

Figure 6

3

Checking the Tire Pressure

No Parts Required

Procedure

Check the tire pressure every 8 hours or daily to ensure proper levels.

The air pressure range in the front and rear tires is 8-22 psi (55-152 kPa).

The air pressure needed is determined by the payload carried. **Lower** air pressure will provide less compaction, a smoother ride, and fewer tire marks. Lower pressure should not be used for heavy payloads at high speeds.

Higher pressures should be used for heavier payloads at higher speeds. Do not exceed the maximum pressure.

4

Setting the Charger Voltage (07299TC only)

No Parts Required

Procedure

Important: The incorrect voltage setting on the battery charger can impair function and damage the charger.

Always make sure the charger voltage setting matches the voltage used to power the charger.

1. Locate the voltage selector on the rear of the charger (Figure 7).
2. Adjust the voltage setting by moving the switch on the voltage selector upward or downward to change the voltage setting (Figure 7).

5. Install the battery retainers and torque the nuts to 150 to 200 in-lb (17 to 22 N-m).
6. Connect the batteries together with the battery cables included in loose parts, as shown in Figure 6. Ensure the cable routing does not allow cables to contact any sharp edges.

Important: Check all high current battery connections to ensure they have been properly secured.

7. Tighten the bolt and secure the other side of the clip with a new bolt (5/16 x 3/4 inch) and flange nut (5/16 inch) (Figure 6).
8. Connect the long, red, main positive lead between the bank of batteries and the vehicle (Figure 6).
9. Connect the long, black, main negative lead between the bank of batteries and the vehicle (Figure 6).

⚠ WARNING

Loose or improperly secured battery connections could damage the vehicle and cables causing sparks. Sparks can cause the battery gasses to explode, resulting in personal injury.

Always ensure the battery polarity when making connections.

10. Torque the nuts securing all battery cables to 120 to 180 inch-lb (13.5 to 21 N-m).
11. Coat the battery terminals with Toro battery terminal protector.
12. Ensure that the rubber boots on each battery cable are securely seated over the battery terminals.

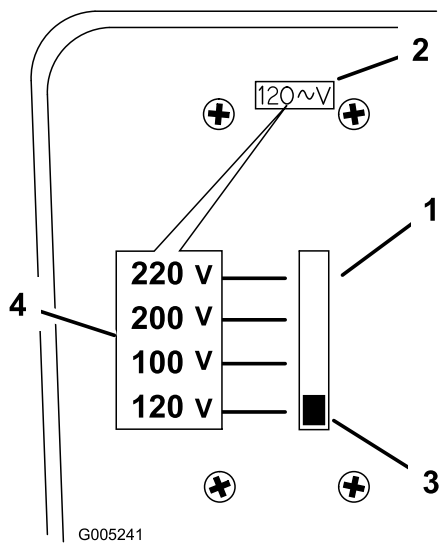

Figure 7

- | | |
|---------------------------|--------------------------------|
| 1. Voltage selector | 3. Switch |
| 2. Voltage setting window | 4. Voltages by switch position |

Always use the appropriate power cord for the power outlet of the country or region where charging will occur. Contact your Authorized Toro Dealer to obtain the correct power cord if necessary.

5

Reading the Manual and Viewing the Safety Video

Parts needed for this procedure:

1	<i>Operator's Manual</i>
1	<i>Parts Catalog</i>
1	Safety Training material
1	Registration Card
1	<i>Predelivery Inspection Form</i>
1	Certificate of Quality
2	Key

Procedure

- Read the *Operator's Manual*.
- View the safety training material.
- Fill out the registration card.
- Complete the *Predelivery Inspection Form*.

Product Overview

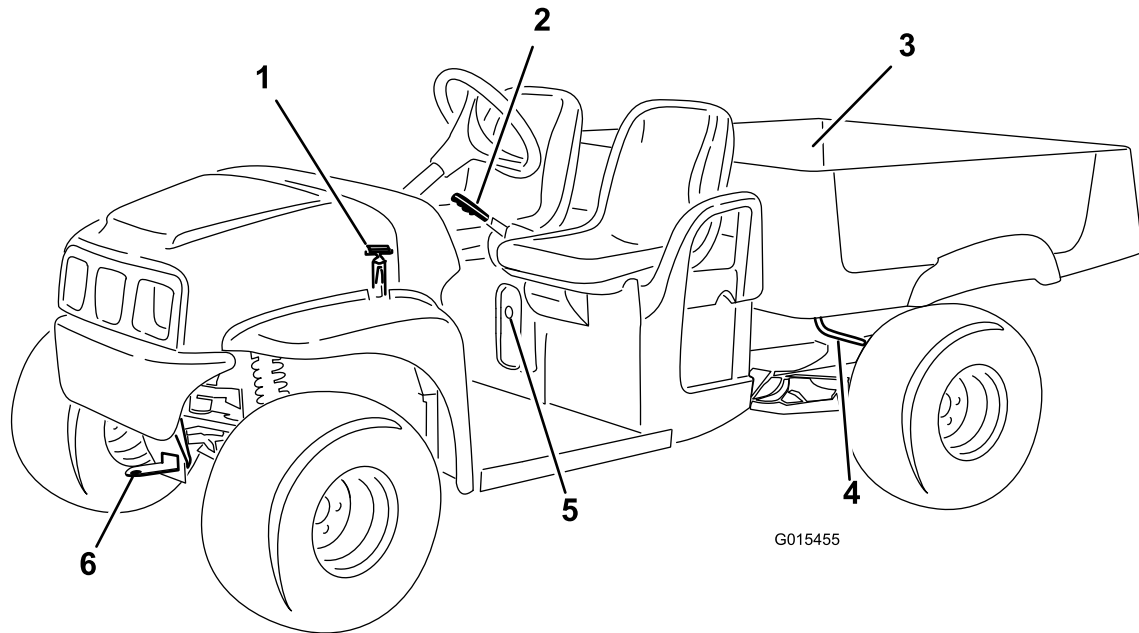

Figure 8

- | | | |
|------------------|----------------------------|------------------------|
| 1. Hood strap | 3. Cargo box | 5. Charging receptacle |
| 2. Parking brake | 4. Cargo box release lever | 6. Towing tongue |

Controls

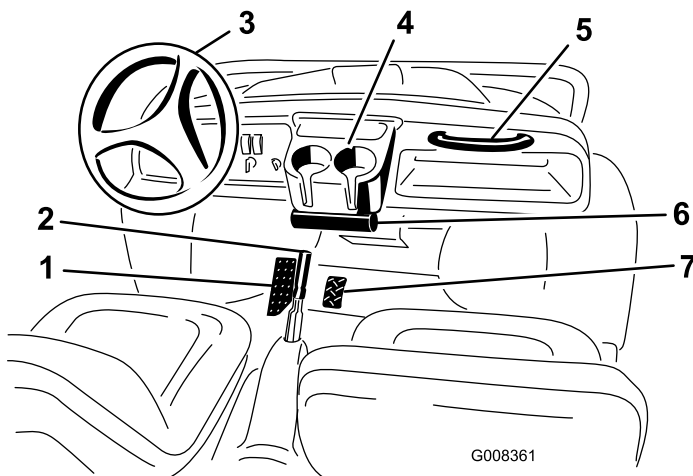

Figure 9

- | | |
|----------------------------------|---------------------------|
| 1. Brake pedal | 5. Passenger hand hold |
| 2. Parking brake, center console | 6. Operator's Manual tube |
| 3. Steering wheel | 7. Accelerator pedal |
| 4. Cup holder | |

Accelerator Pedal

The accelerator pedal (Figure 9) gives the operator the ability to vary ground speed of the vehicle. Pressing the pedal when the On/Off switch is On starts the

motor. Pressing the pedal farther increases ground speed. Releasing the pedal will slow the vehicle and the motor will stop.

Note: Pressing down on the pedal and holding it there before the key is turned to the On position will cause a safety interlock to engage and the machine will not operate. Release the pedal and the interlock will disengage and allow normal operation of the machine to resume.

Brake Pedal

The brake pedal is used to stop or slow the vehicle (Figure 9).

⚠ CAUTION

Brakes can become worn or can be incorrectly adjusted resulting in personal injury.

If brake pedal travels to within 1 inch (25 mm) of the vehicle floor board, the brakes must be adjusted or repaired.

Parking Brake

The parking brake is between the seats (Figure 9). Whenever the vehicle is shut off, the parking brake must be engaged to prevent accidental movement of the vehicle. To engage the parking brake, pull back on

the lever. To disengage, push the lever forward. If the vehicle is parked on a steep grade, make sure that the parking brake is applied.

On/Off Switch

The On/Off switch (Figure 10) used to activate the electrical systems of the vehicle, has two positions: Off and On. Rotate the key clockwise to the On position to allow operation of the vehicle and accessories. After stopping the vehicle, rotate the key counterclockwise to the Off position. Remove the key when leaving the vehicle.

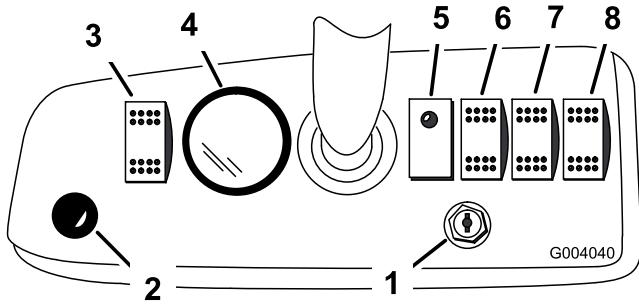

Figure 10

- | | |
|---------------------------------|--------------------------------------|
| 1. On/Off switch | 5. Vehicle status light |
| 2. Horn button (TC Models Only) | 6. Power cargo bed switch (optional) |
| 3. Light switch | 7. Rear lift switch (optional) |
| 4. Battery/hour meter | 8. Vehicle direction switch |

Horn Button (TC Models Only)

Press the horn button to sound the horn (Figure 14).

Battery Discharge Indicator

The battery/hour meter provides you with an indication of how much charge is contained in the batteries (Figure 10 and Figure 14) and the number of operating hours on the vehicle. The battery meter is located at the top of the LCD screen. When the vehicle batteries are fully charged, ten bars extend from the 0 to the 1 position. As the charge is used, bars disappear starting on the right side. For detailed information on the battery meter, refer to Understanding and Using the Battery System in Operation (page 20).

The hour meter is located at the bottom of the LCD screen. It logs operating hours whenever the key is in the On position and the vehicle is in motion.

Vehicle Direction Switch

Use this switch (Figure 10) to toggle between forward and reverse operation.

Vehicle Status Light

The vehicle contains a computer that monitors the state of the vehicle electrical systems. This computer communicates the status of the vehicle to you through the vehicle status light. Always check this light when you turn the On/Off switch to the On position (Figure 14) When there are no problems and the vehicle is operational, the light is on.

When there is a problem, the light flashes. The light flashes at various intervals for different problems and events. If the light blinks, refer to Always onThe system is functioning properly.None (page) for a description of the flash codes.

Light Switch

Use this switch to turn the headlights on and off (Figure 10).

Cargo Bed Lift Switch (Optional)

Use this switch to raise and lower the cargo bed (Figure 10).

Rear Lift Switch (Optional)

Use this switch to raise and lower the rear lift (Figure 10).

Supervisor Speed Limit Switch

The supervisor speed limit switch, located under the cup holder (Figure 11) has two positions: Off and On. Rotate the key clockwise to the On position to limit the maximum vehicle speed to a factory setting of 12 mph (19 kph). Rotate the key counterclockwise to the Off position to restore the maximum speed of the vehicle.

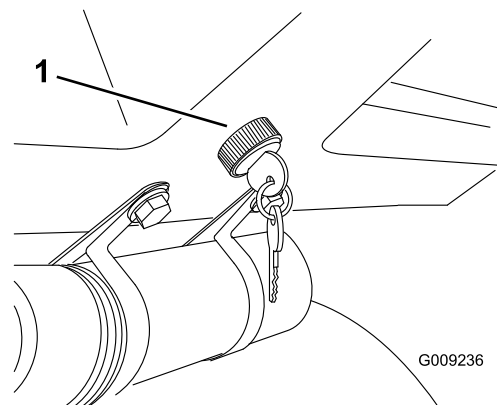

Figure 11

1. Supervisor speed limit switch

Passenger Hand Holds

The passenger hand holds are located on the right side of the dash panel and at the outside of each seat (Figure 12).

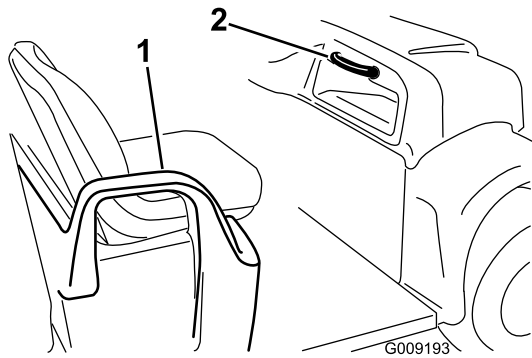

Figure 12

1. Hip restraint

2. Passenger hand hold

Specifications

Note: Specifications and design are subject to change without notice.

Base weight	1600 lb (726 kg)
Base weight without Batteries	1025 lb (765 kg)
Rated capacity (on level ground)	1200 lb (544.5 kg) total, including 200 lb (90.7 kg) operator and 200 lb (90.7 kg) passenger, load, trailer tongue weight, gross trailer weight, accessories, and attachments
Maximum gross vehicle weight (GVW) (on level ground)	2800 lb (1270 kg) total, including all of the weights listed above
Maximum cargo capacity (on level ground)	800 lb (362 kg)* total, including trailer tongue weight and gross trailer weight
Tow capacity:	
Standard Hitch	Tongue weight 50 lb (23 kg) Maximum trailer weight 400 lb (182 kg)
Heavy Duty Hitch	Tongue weight 100 lb (45 kg) Maximum trailer weight 800 lb (363 kg)
Overall width	59 in (150 cm)
Overall length	119.75 in (304.2 cm)
Ground clearance	10 inches (25.4 cm) at the front with no load or operator, 7 inches (18 cm) at the rear with no load or operator
Wheel base	83 in (210.8 cm)
Wheel tread (center line to center line)	49 inches (124.5 cm) in the front, 46-1/2 inches (118 cm) in the rear
Cargo box length	46 inches (116.8 cm) inside, 52-1/4 inches (132.7 cm) outside
Cargo box width	49 inches (124.5 cm) inside, 59 inches (150 cm) at outside of the molded fenders
Cargo box height	10 inches (25.4 cm) inside

* Specifications listed are with Trojan T145 batteries.

Attachments/Accessories

A selection of Toro approved attachments and accessories is available for use with the machine to enhance and expand its capabilities. Contact your Authorized Service Dealer or Distributor or go to www.Toro.com for a list of all approved attachments and accessories.

Operation

Note: Determine the left and right sides of the machine from the normal operating position.

Think Safety First

Please carefully read all of the safety instructions and decals in the safety section. Knowing this information could help you or bystanders avoid injury.

Pre-Starting Checks

Check the following items each time you begin using the vehicle for the day:

- Check the tire pressure.
- Check the brake pedal operation.
- Check to see that the lights are working.
- Turn the steering wheel to the left and right to check steering response.
- Check for loose parts and any other noticeable malfunctions. Make sure the vehicle is off and all moving parts have stopped before checking for loose parts and other malfunctions.

If any of the above items are not correct, notify your mechanic or check with your supervisor before taking the vehicle out for the day. Your supervisor may want you to check other items on a daily basis, so ask what your responsibilities are.

Checking the Tire Pressure

Service Interval: Before each use or daily

Check the tire pressure every 8 hours or daily to ensure proper levels.

The air pressure range in the front and rear tires is 8–22 psi (55–103 kPa).

The air pressure needed is determined by the payload carried. The lower the air pressure, the less the compaction, smoother the ride, and tire marks are minimized. Lower pressure should not be used for heavy payloads at high speeds.

Higher pressures should be used for heavier payloads at higher speeds. Do not exceed the maximum pressure.

Operating the Vehicle

1. Disconnect the battery charger.

2. Sit in the Operator's seat, insert the key into the On/Off switch, and rotate the key clockwise to the On position.
3. Move the vehicle direction switch button to the desired position.
4. Release the parking brake.
5. Slowly step on the accelerator pedal to drive the vehicle.

Stopping the Vehicle

Important: When stopping the vehicle on an incline, use the brake to stop the vehicle and the parking brake to hold it in place. Using the accelerator to stall the vehicle can damage the vehicle.

To stop the vehicle, remove your foot from the accelerator pedal and slowly press the brake pedal.

Note: Stopping distance may vary depending on the vehicle load and speed.

Parking the Vehicle

1. Engage the parking brake and rotate the On/Off key to Off.
2. Remove the key from the switch to prevent accidental starting.

Understanding and Using the Battery System

Understanding Deep Cycle Batteries

The vehicle contains 8 deep cycle, lead-acid batteries which supply power to the motor and accessories. A deep cycle battery is not the same as an automobile battery. An automobile battery is designed to provide a surge of power to start the vehicle and moderate power to run the lights and accessories when the motor is off or idling. The alternator then continuously recharges it as the automobile runs. As such, an automobile battery seldom drops below 90% of maximum charge level.

A deep cycle battery is designed to be a primary power source to provide a sustained output. Deep cycle batteries are typically discharged as low as 20% to 30% of the maximum charge level. A discharge this low is considered a deep discharge.

Lead acid batteries produce electricity through a chemical reaction between coated lead plates and

sulfuric acid. Charging a battery reverses the chemical reaction, allowing the battery to once again produce electricity.

A battery is a perishable item that has a limited life time (Figure 13). When a battery is new, it requires a break-in period to establish efficient electrical production. This break in period usually requires 20 to 50 discharge/charge cycles.

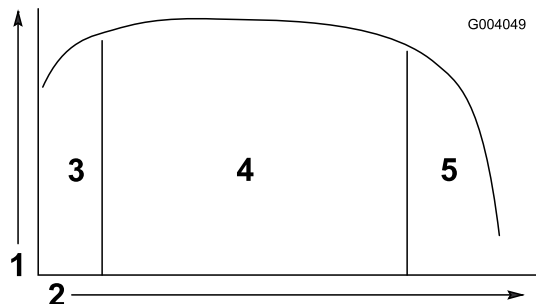

Figure 13

- | | |
|--------------------------------------|------------------------|
| 1. Battery capacity | 4. Prime battery life |
| 2. Discharge/charge cycles | 5. End of battery life |
| 3. Break-in period (20 to 50 cycles) | |

After the break-in period, the battery will maintain a high capacity for many cycles. The number of cycles a battery will perform is dependant on the following:

- Battery maintenance—improper maintenance will severely reduce the life of the batteries.
- Depth of discharge between charge cycles—**the deeper the batteries are discharged on a regular basis between charges, the less life they will have.**
- Recharge frequency—charge the batteries whenever they are not in use. **Fully discharging the batteries will damage them and reduce their life.**

At the end of the battery life, the coating on the lead plates begins to deteriorate, causing the batteries to rapidly lose electric capacity.

Using the Battery System

When your batteries are fully charged, the battery meter will have ten bars showing from left to right (Figure 14).

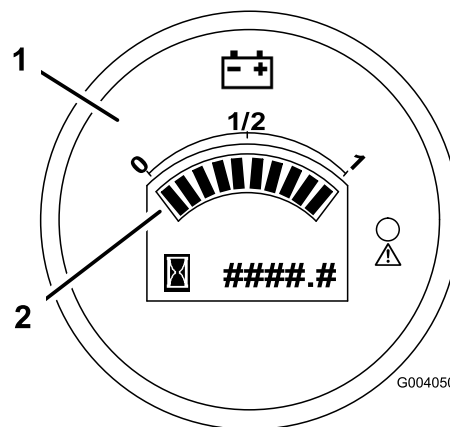

Figure 14

- | | |
|-----------------------|--------------------------|
| 1. Battery/hour meter | 2. Charge indicator bars |
|-----------------------|--------------------------|

As you use the vehicle, the bars will disappear as the electrical capacity of the batteries is used.

When only 2 bars are left, the red warning light on the meter will illuminate and the battery icon will begin flashing on the screen (Figure 15). This indicates that the battery capacity is nearly drained and you should charge the batteries as soon as possible to prevent battery damage.

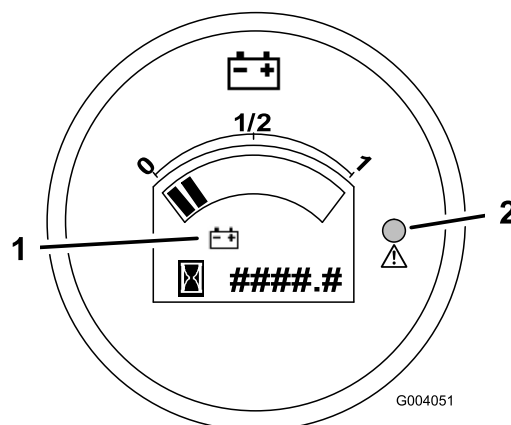

Figure 15

- | | |
|-----------------|---------------------|
| 1. Battery icon | 2. Warning light—on |
|-----------------|---------------------|

When only one bar is left, the warning light will begin flashing and the vehicle will go into an energy saving mode (Figure 16). In this mode, the vehicle will only drive at 3 mph. Recharge the batteries immediately to prevent serious damage to them.

If the batteries become fully discharged, the vehicle will shut down. **Do not allow the batteries to become fully discharged.**

Important: To obtain maximum battery life, always charge the batteries when there are 2 or more bars visible on the screen. Depleting the

batteries lower than 2 bars, especially on a regular basis, will reduce the life of the batteries.

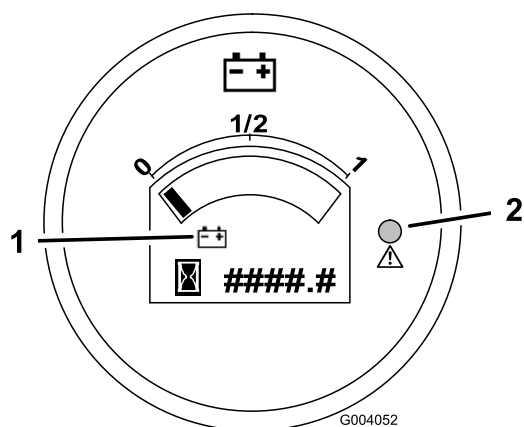

Figure 16

1. Battery icon
2. Warning light-flashing

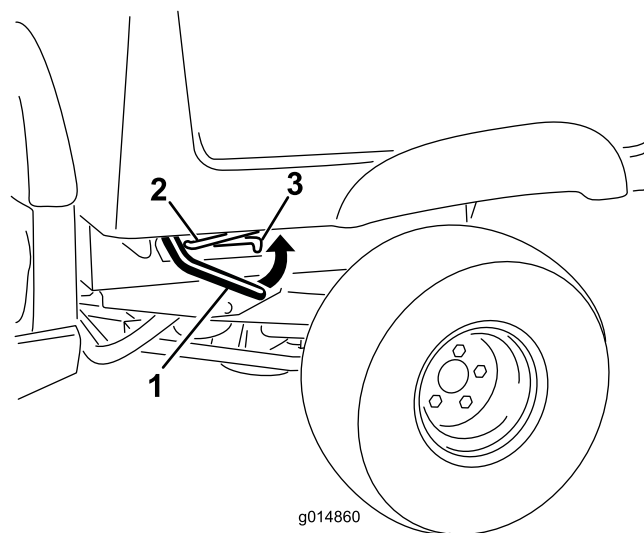

Figure 17

1. Lever
2. Prop rod
3. Detent slot

Operating the Cargo Box

Raising the Box

⚠ WARNING

Driving the vehicle with the cargo box raised may cause the vehicle to tip or roll easier. The box structure may become damaged if you operate the vehicle with the box raised.

- Only operate the vehicle when the cargo box is down.
- After dumping a load, lower the cargo box.

⚠ CAUTION

If a load is concentrated near the back of the box when you release the latches, the box may unexpectedly tip open injuring you or bystanders.

- Center loads in the box if possible.
- Hold the box down and ensure that no one is leaning over the box or standing behind it when releasing the latches.
- Remove all cargo from the box before lifting the box to service the vehicle.

1. Lift the lever on either side of the box and lift the box up (Figure 17).

2. Pull the prop rod into the detent slot, securing the box (Figure 17).

Lowering the Box

⚠ WARNING

The weight of the box may be heavy. Hands or other body parts could be crushed.

Keep hands and other body parts clear when lowering the box.

Pull the prop rod out of the detent slot and lower the box until it latches into place.

Adjusting the Box Latches

If the box latch does not latch tightly, vibrating up and down as you drive the vehicle, you can adjust the latch posts to make the latches fit snugly.

1. Loosen the nut on the end of the latch post (Figure 18).

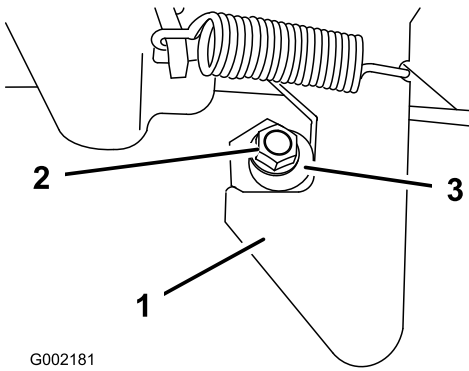

Figure 18

- 1. Latch
- 2. Nut
- 3. Latch post

2. Turn the latch post clockwise until it is snug against the latch and then tighten the nut (Figure 18).
3. Repeat this procedure for the latch on the other side of the vehicle.

Operating the Tailgate Latches

- To open the tailgate, pull outward and lift the latch up, then slowly lower the tailgate (Figure 19).

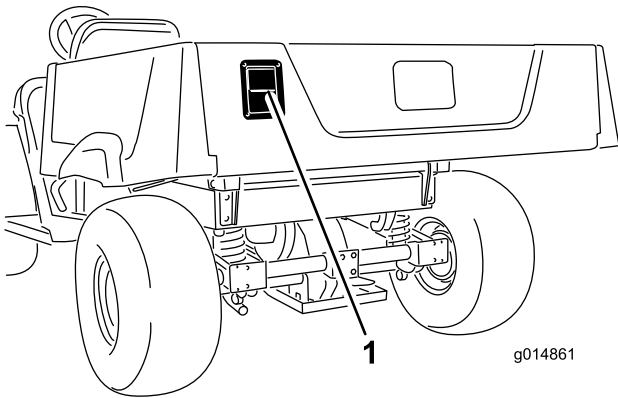

Figure 19

- 1. Tailgate latch

- To close the tailgate, lift the tailgate upward and push it closed until it locks in place.

Breaking in a New Vehicle

To provide proper performance and long vehicle life, follow these guidelines for the first 100 operating hours:

- Avoid hard braking situations for the first several hours of new vehicle break-in operation. New brake linings may not be at optimum performance until several hours of use has caused the brakes to become burnished (broken-in).

- Refer to the Maintenance section for any special low hour checks.
- Check the front suspension positioning and adjust it if necessary; refer to Adjusting the Front Suspension in Drive System Maintenance (page 31).

Loading the Cargo Box

The capacity of the cargo box is 13 ft³ (0.37 m³). The amount (volume) of material that can be placed in the box without exceeding the vehicle load ratings can vary greatly depending on the density of the material. For example, a level box of wet sand weighs 1500 lb (680 kg), which greatly exceeds the load rating.

See the table below for load volume limits with various materials:

Material	Material (lb/ft ³)	Max. cargo box capacity (on level ground)
Gravel, dry	95	1/2 full
Gravel, wet	120	1/3 full
Sand, dry	90	1/2 full
Sand, wet	120	1/3 full
Wood	45	Full
Bark	<45	Full
Earth, packed	100	1/2 full

Transporting the Vehicle

For moving the vehicle long distances, a trailer should be used. Make sure that the vehicle is secured to the trailer. Refer to Figure 20 and Figure 21 for the location of the tie-down points.

⚠ CAUTION

Loose seats may fall off of the vehicle and trailer when transporting and land on another vehicle or become an obstruction on the road.

Remove the seats or make sure that the seats are securely fastened in the detents.

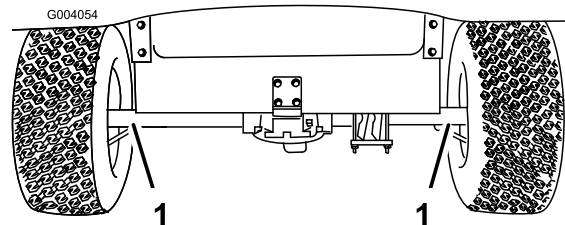

Figure 20

- 1. Tie down points

Towing the Vehicle

In case of an emergency, the vehicle can be towed for a short distance. However, we do not recommend this as a standard procedure.

⚠ WARNING

Towing at excessive speeds could cause a loss of steering control, resulting in personal injury.

Never tow the vehicle faster than 5 mph (8 km/h).

Towing the vehicle is a two person job. If the machine must be moved a considerable distance, transport it on a truck or trailer; refer to Transporting the Vehicle.

1. Turn off the On/Off switch and remove the key.

Important: If you tow the vehicle with the key in the On position, the electrical system may be damaged.

2. Affix a tow line to the tongue on the front of the frame (Figure 21).
3. Release the parking brake.

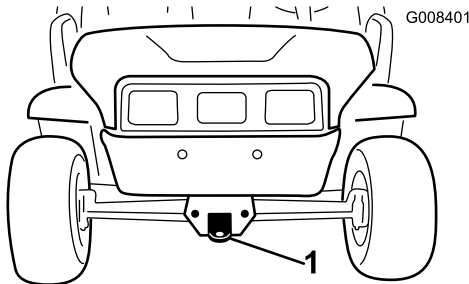

Figure 21

1. Towing tongue and tie down point

200 lb (90 kg) then the maximum cargo load = 600 lb (272 kg).

To provide adequate braking and traction, always load the cargo box when trailering. Do not exceed the GTW or GVW limits.

Avoid parking a vehicle with a trailer on a hill. If you must park on a hill, engage the parking brake and block the trailer tires.

Towing a Trailer

The vehicle is capable of pulling trailers. Two types of tow hitches are available for the vehicle, depending on your application. Contact your Authorized Toro Distributor for details.

When hauling cargo or towing a trailer, do not overload your vehicle or trailer. Overloading can cause poor performance or damage to the brakes, axle, motor, transaxle, steering, suspension, body structure, or tires. Always load a trailer with 60% of the cargo weight in the front of the trailer. This places approximately 10% of the Gross Trailer Weight (GTW) on the tow hitch of the vehicle.

The maximum cargo load shall not exceed 800 lb (362 kg), including the GTW. For example, if the GTW =

Maintenance

Note: Determine the left and right sides of the machine from the normal operating position.

Recommended Maintenance Schedule(s)

Maintenance Service Interval	Maintenance Procedure
Before each use or daily	<ul style="list-style-type: none"> • Check the tire pressure. • Charge the batteries. • Check the brake fluid level.
Every 25 hours	<ul style="list-style-type: none"> • Clean the batteries. • Check the battery electrolyte level.
Every 100 hours	<ul style="list-style-type: none"> • Grease the bearings and bushings. • Inspect the condition and wear of the tires. • Torque the wheel lug nuts to 45-65 ft-lb (61-88 N-m). • Check the front wheel toe-in and camber. • Check the transaxle fluid. • Inspect the brakes.
Every 200 hours	<ul style="list-style-type: none"> • Check the parking brake operation.
Every 800 hours	<ul style="list-style-type: none"> • Change the transaxle fluid.

Daily Maintenance Checklist

Duplicate this page for routine use.

Maintenance Check Item	For the week of:						
	Mon.	Tues.	Wed.	Thurs.	Fri.	Sat.	Sun.
Check brake and parking brake and adjust as needed.							
Check unusual operating noises.							
Check tire pressure.							
Check fluid leaks.							
Check instrument operation.							
Check accelerator operation.							
Lubricate all grease fittings.							
Touch up damaged paint.							

⚠ CAUTION

If you leave the key in the On/Off switch, someone could accidentally start the vehicle and seriously injure you or other bystanders.

Remove the key from the On/Off switch and disconnect a battery cable before you do any maintenance.

⚠ WARNING

The bed must be raised to perform some routine maintenance.

A raised bed can fall and injure persons that are underneath it.

- Always use the prop rod to hold the bed up before working under it.
- Remove any load material from the bed before working under it.

Premaintenance Procedures

Maintaining the Vehicle under Special Operating Conditions

If the vehicle is subjected to any of the conditions listed below, maintenance should be performed twice as frequently.

- Desert operation
- Cold climate operation (below 50° F [10 degrees C])
- Trailer towing
- After extended operation in mud, sand, water, or similar dirty conditions, have your brakes inspected and cleaned as soon as possible. This will prevent any abrasive material from causing excessive wear.

Jacking the Vehicle

Whenever the vehicle is run for routine maintenance and/or motor diagnostics, the rear wheels of the vehicle should be 1 inch (25 mm) off the ground with the rear axle supported on jack stands.

⚠ DANGER

The vehicle may be unstable when using a jack. It could slip off the jack, injuring anyone beneath it.

- Do not start the vehicle while the vehicle is on a jack.
- Always remove the key from the On/Off switch before getting off of the vehicle.
- Block the tires when the vehicle is on a jack.

The jacking point at the front of the vehicle is on the front of the frame behind the towing tongue (Figure 22). The jacking point at the rear of the vehicle is under the axle tubes (Figure 23).

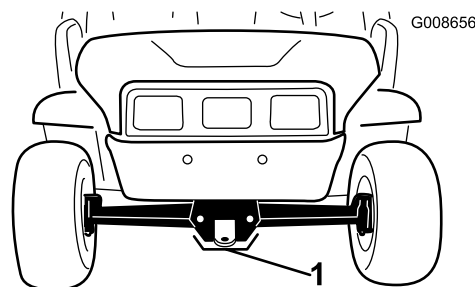

Figure 22

1. Front jacking point

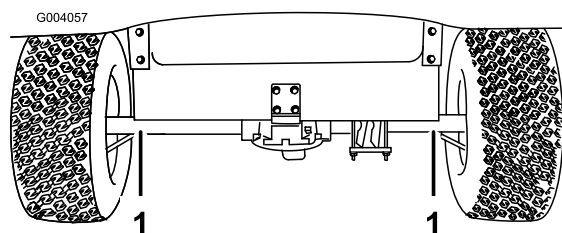

Figure 23

1. Rear jacking points

Accessing the Hood

1. Release the rubber straps on both sides of the hood (Figure 24).

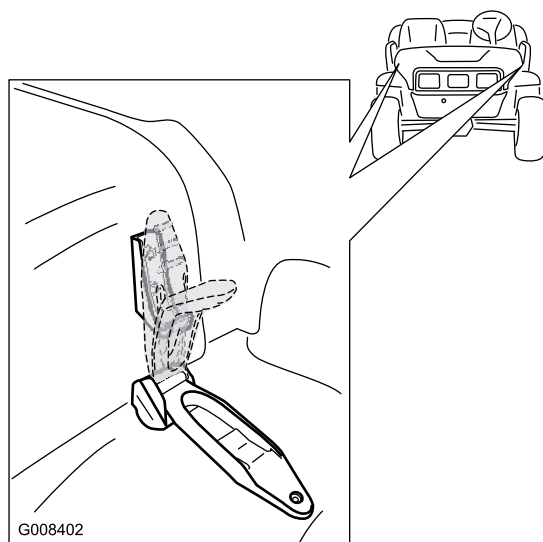

Figure 24

2. Raise the hood.
3. Lower the hood to close and use rubber retaining straps to secure the hood.

Lubrication

Lubricate all of the bearings and bushings every 100 hours or once a year, whichever occurs first. Grease them more frequently when using the vehicle for heavy-duty operations.

Grease Type: Number 2 General Purpose Lithium Base Grease

Adding Grease

Service Interval: Every 100 hours

1. Wipe the grease fitting clean so foreign matter cannot be forced into the bearing or bushing.
2. Pump grease into the bearing or bushing.
3. Wipe off excess grease.

The grease fittings are located at the four tie rod ends (Figure 25) and the two king pins (Figure 26).

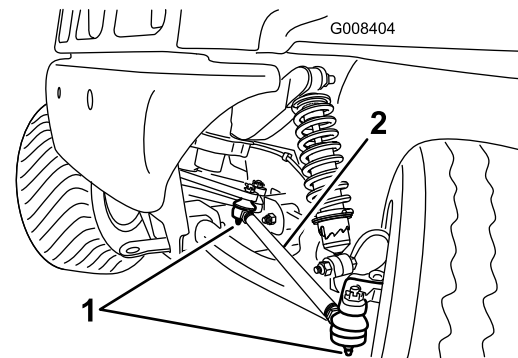

Figure 25
Left side shown

1. Grease fitting
2. Tie rod

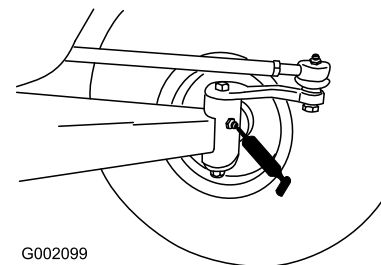

Figure 26

Electrical System Maintenance

Maintaining the Batteries

⚠ WARNING

Battery terminals or metal tools could short against metal vehicle components causing sparks. Sparks can cause the battery gasses to explode, resulting in personal injury.

- When removing or installing the battery, do not allow the battery terminals to touch any metal parts of the vehicle.
- Do not allow metal tools to short between the battery terminals and metal parts of the vehicle.
- Always keep the battery retainers in place to protect and secure the batteries.

WARNING

CALIFORNIA Proposition 65 Warning

Battery posts, terminals, and related accessories contain lead and lead compounds, chemicals known to the State of California to cause cancer and reproductive harm.
Wash hands after handling.

Cleaning the Batteries

Service Interval: Every 25 hours

Clean the batteries every day before use.

1. Ensure that all of the battery caps are tight.
2. Use a paper towel to clean the batteries.
3. If the battery terminals are corroded, clean them with a solution of four parts water and one part baking soda. Also, clean the posts and cable clamps with a post and clamp cleaner. The posts and clamps should have a bright metallic shine.
4. Apply a light coating of Toro battery terminal protector.

Charging the Batteries

Service Interval: Before each use or daily

A charger is supplied with the vehicle. Always keep the charger in a dry location. For maximum battery life,

charge the batteries whenever you are not using the vehicle. Depending on how discharged the batteries are, it may take up to 16 hours to charge the batteries to full capacity.

Important: Lead-acid batteries do not develop a charge memory and do not need to be fully discharged before charging them. *Fully discharging the batteries may damage them.* Charge the batteries any time the vehicle is not in use; refer to Using the Battery System section in Operation (page 20).

⚠ WARNING

Charging the battery produces gasses that can explode.

Never smoke near the batteries and keep sparks and flames away from them.

1. Position the vehicle in a well ventilated area near a suitable power outlet.
2. Connect the charger cord to the charging receptacle on the vehicle (located on the panel between the seats).
Note: Make sure the charger voltage setting matches the voltage at the power outlet being used.
3. Plug the charger power cord into the power outlet.
While the batteries are charging, the green light on the charger will blink on and off. When the batteries are fully charged, the green light stops blinking and stays on.
4. Disconnect the cord from the power outlet.
5. Disconnect the charger from the vehicle.

Important: Do not carry the charger on the vehicle. Excessive or prolonged jarring may damage it.

Adding Water to the Batteries

Service Interval: Every 25 hours

Check the electrolyte level and add water if needed every 25 operating hours or, if the vehicle is in storage, every 30 days. **Use only clean, distilled water to fill the batteries.**

⚠ DANGER

Battery electrolyte contains sulfuric acid which is a deadly poison and causes severe burns.

- Do not drink electrolyte and avoid contact with skin, eyes or clothing. Wear safety glasses to shield your eyes and rubber gloves to protect your hands.
- Fill the batteries where clean water is always available for flushing the skin.
- Never add acid to a battery.

1. Raise the cargo bed, turn the key off, and remove it.
2. Remove the filler caps from each battery.
3. If the electrolyte is not over the top of the plates in each battery cell, add just enough distilled water to cover the plates.
4. Replace the filler caps on all batteries.
5. Charge the batteries until a full charge is achieved; refer to Charging the Batteries.
6. Once the batteries are fully charged, remove the filler caps from each battery.
7. Add just enough distilled water to bring the electrolyte level to 1/8 inch (3 mm) below the bottom of each fill well (Figure 27).

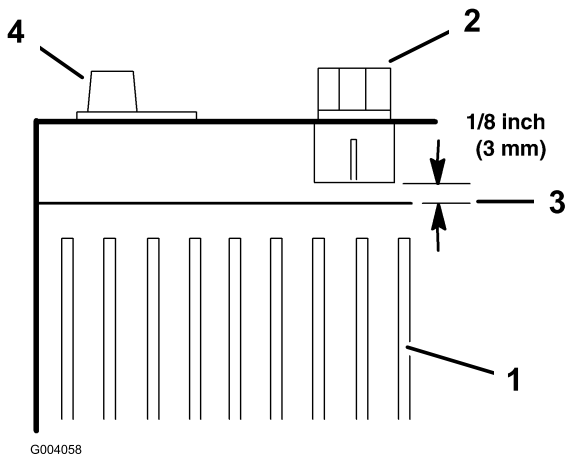

Figure 27

- | | |
|-------------------|----------------------|
| 1. Battery plates | 3. Electrolyte level |
| 2. Filler cap | 4. Battery terminal |

Important: Do not overfill the battery. Electrolyte will overflow onto other parts of the vehicle and severe corrosion and deterioration may result. Also, overfilling the battery will reduce the life of the battery.

8. Replace the filler caps on all batteries.

Replacing Used Batteries

When the vehicle begins to show a loss of range or when the length of the discharge/charge cycle is significantly reduced, the batteries are probably getting old and losing their ability to hold a charge. Take the vehicle to an Authorized Service Dealer and have them test the batteries to determine whether the batteries need to be replaced. The Dealer can then replace the batteries for you. If you wish to replace the batteries yourself, use the following procedure:

1. Raise the cargo bed, turn the key off, and remove it.
2. Disconnect the long, black, main negative lead running from the bank of batteries to the vehicle from the battery post (Figure 28).

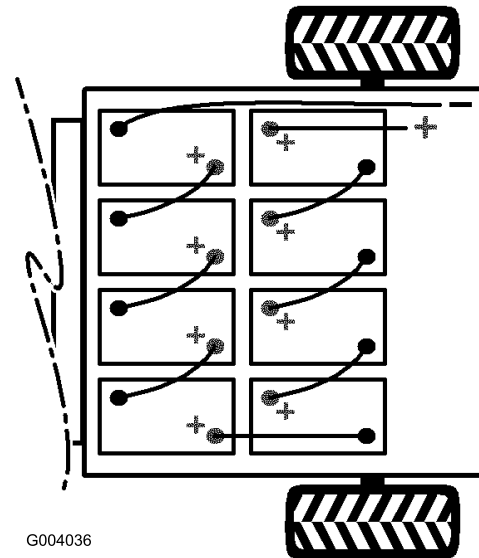

Figure 28

3. Remove the long, red, main positive lead running from the bank of batteries to the vehicle from the battery post (Figure 28).
 4. Disconnect all of the battery leads from the batteries.
 5. Remove the battery retainers located between the batteries.
 6. Remove all of the batteries and recycle them according to your local codes.
 7. Install new batteries in the places vacated by the old batteries
- Note:** Pay attention to the battery polarity when installing the new batteries (Figure 28).
8. Install the battery retainers and torque the nuts to 150 to 200 in-lb (17 to 22 N-m).
 9. Connect the batteries together with the battery cables removed previously, as shown in Figure 28.

10. Connect the long, red, main positive lead between the bank of batteries and the vehicle (Figure 28).
11. Connect the long, black, main negative lead between the bank of batteries and the vehicle (Figure 28).
12. Torque the nuts securing all battery cables to 120 to 180 inch-lb (13.5 to 21 N-m).
13. Coat the battery terminals with Toro battery terminal protector.
14. Ensure that the rubber boots on each battery cable are securely seated over the battery terminals.

Storing the Batteries

Charge the batteries fully before placing the vehicle into storage. Plug the charger into a wall outlet while the vehicle and batteries are in storage. Leave the charger plugged into a wall outlet and charging receptacle during storage to ensure that the batteries stay charged and do not freeze; otherwise, charge the batteries at least once every 3 months.

Replacing the Fuses

There are 2 fuses in the electrical system. They are located beneath the dash on the driver's side (Figure 29).

Open	10 A
Power Point	10 A
Lights and Horn	10 A

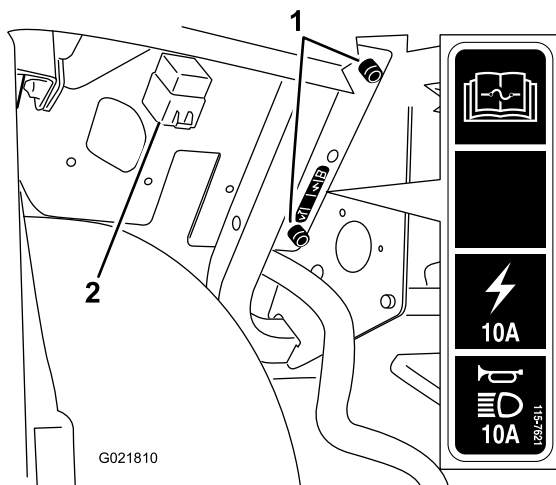

Figure 29

1. Vehicle fuse holder
2. Relay

Replacing the Headlights

Before performing any maintenance set the parking brake, turn the On/Off switch to Off, and remove the key.

Release the retaining straps on the hood and raise the hood to access the headlights.

Replacing the Bulbs

⚠ CAUTION

The halogen bulbs become extremely hot when in operation. Handling a hot bulb can cause severe burns and personal injury.

Always allow enough time for the bulbs to cool before replacing them. Use care whenever handling the bulb.

⚠ CAUTION

Any surface contamination can damage the headlight bulb and lead to its failure or explosion creating a serious safety hazard.

Head light lamps should be handled without touching the clear quartz, either by using a clean paper towel or carefully holding the base.

Specification: See your *Parts Catalog*.

1. Disconnect the electrical harness from the bulb housing on the back of the lamp.
2. Remove the protective rubber boot (Figure 30).

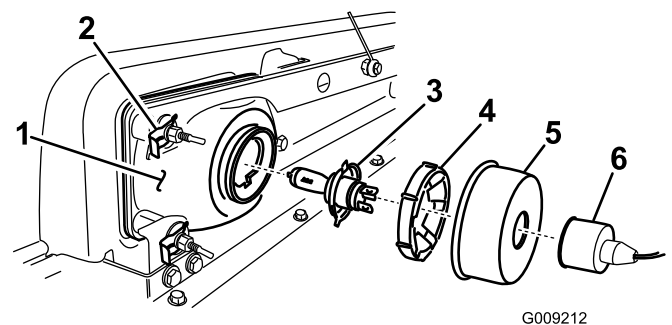

Figure 30

1. Headlight
 2. Speed clip and flat washer
 3. Headlight bulb
 4. Retaining ring
 5. Rubber boot
 6. Headlight bulb harness connection
3. Release the plastic retaining ring by turning it 1/4 turn counter clockwise. Remove the ring.
 4. Remove the bulb assembly by moving it rearward, out of the lamp housing.
 5. Install a new bulb into the lamp housing. Use a paper towel to grasp the new bulb with handling it to avoid contaminating the surface.
 6. Secure the bulb in place by installing the retaining ring. Turn the ring 1/4 turn clockwise to lock it in place.

7. Install the rubber boot over the ring and bulb.
8. Connect the bulb to the electrical harness.

Replacing the Headlight

When removing or replacing the headlight assembly, disconnect the wiring harness to the bulb assembly if the bulb is to be removed with the lamp.

1. Remove the speed clips and washers securing the headlight in place. Retain all parts.
2. Remove the headlight assembly by moving it forward through the opening in the front bumper (Figure 30).
3. Install the new headlight through the opening in the bumper (Figure 30). Ensure the adjustment posts are lined up with the holes in the mounting bracket in the bumper.
4. Secure the headlight assembly with the washers and speed clips removed previously.
5. Attach the headlight to the wire harness removed previously.
6. Adjust the headlights to direct the beams to the desired position.

Adjusting the Headlights

Use the following procedure to adjust the headlight beam position whenever a headlight assembly is replaced or removed.

1. Turn the key to the On position and turn on the headlights.
2. At the headlight assembly, use the fasteners to pivot the headlight assembly and affect the cast beam position.

Drive System Maintenance

Inspecting the Tires

Service Interval: Every 100 hours

Every 100 hours

Check the tire condition at least every 100 hours of operation. Operating accidents, such as hitting curbs, can damage a tire or rim and also disrupt wheel alignment, so inspect tire condition after an accident.

Check the wheels to ensure that they are mounted securely. Torque the lug nuts to 45-65 ft-lb (61-88 N-m).

Adjusting Front Wheel Toe-In and Camber

Service Interval: Every 100 hours/Yearly (whichever comes first)—Check the front wheel toe-in and camber.

Important: You will need to obtain tool number TORO6010 from your Toro Distributor to perform this procedure

The toe-in should be 0-1/4 inch (0-6 mm) and the camber should be 0+1/2 degree, i.e., the bottom of the wheel rims angled in 0.09 inch (2.3 mm) more than the top, with the following parameters:

- Check the tire pressure to ensure that the front tires are inflated to 12 psi (82 kPa).
 - Either, add weight to the driver's seat equal to the average operator who will run the machine or have an operator sit on the seat. The weight or operator must remain on the seat for the duration of the procedure.
 - On a level surface, roll the vehicle straight back 6 to 10 ft (2 to 3 m) and then straight forward to the original starting position. This will allow the suspension to settle into the operating position.
 - Measure the toe-in with the wheels facing straight ahead.
1. To check the camber, place a 90 degree square on the ground with the vertical edge touching the face of the tire (Figure 31).

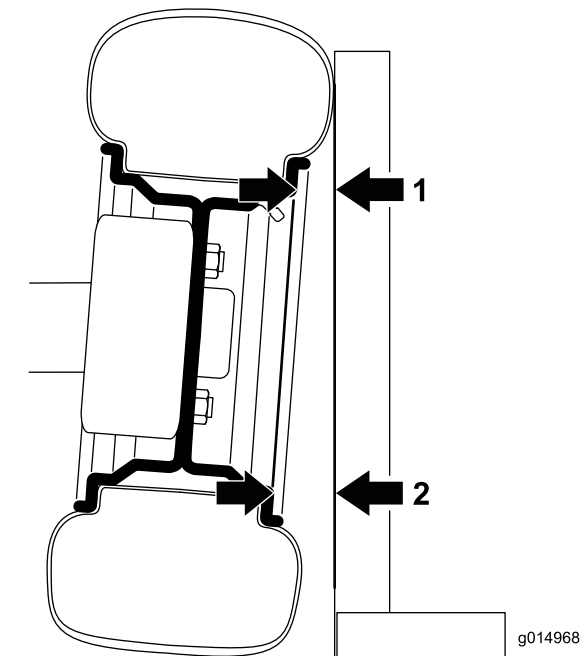

Figure 31

Left, front wheel shown from the front; the angle is exaggerated for illustrative purposes

1. Measure here
2. Measure here—should be 0.09 inch (2.3 mm) larger than the measurement at 1

2. Measure from the same part of the rim on the top and bottom of the tire to the square (Figure 31). The distance of the bottom measurement should be 0.09 inch (2.3 mm) larger than the top measurement. Complete the measurement on both front tires before adjusting.

Complete the following procedure for each tire that needs adjusting:

- A. Using tool TORO6010, rotate the collar on the shock absorber to change the length of the spring (Figure 32).
 - If the bottom measurement was too short, reduce the length of the spring.
 - If the bottom measurement was too long, increase the length of the spring.

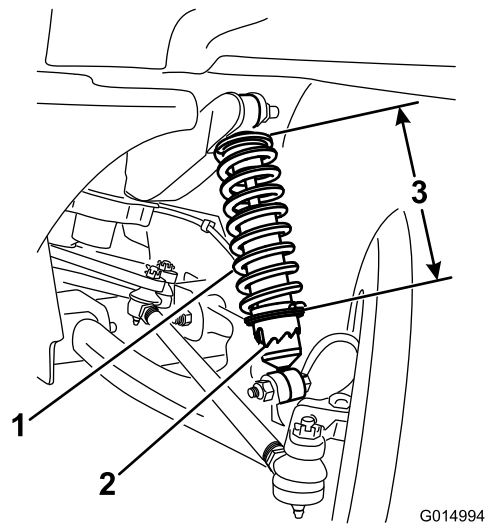

Figure 32

1. Shock absorber spring
2. Collar
3. Spring length

- B. On a level surface, roll the vehicle straight back 6 to 10 ft (2 to 3 m) and then straight forward to the original starting position.

- C. Repeat this procedure, starting with step 1 until the camber is set correctly for both front wheels.

3. Measure the distance between both of the front tires at the axle height at both the front and rear of the front tires (Figure 33).

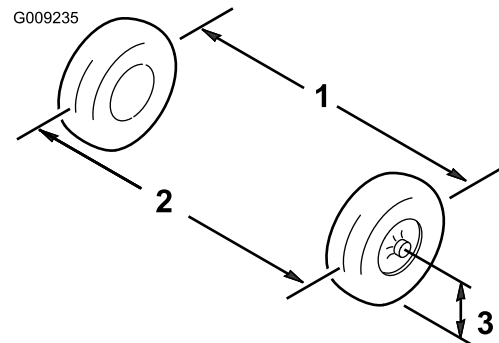

Figure 33

1. Tire center line-back
2. Tire center line-front
3. Axle center line

4. If the measurement does not fall within 0-1/4 inch (0-6 mm), loosen the jam nuts at both ends of the tie rods (Figure 34).

Brake Maintenance

Inspecting the Brakes

Service Interval: Every 100 hours

Brakes are a critical safety component of the vehicle. As with all safety components, they should be closely inspected at regular intervals to ensure optimum performance and safety. The following inspections should be done every 100 hours:

- Inspect the brake shoes for wear or damage. If the lining (brake pad) thickness is less than 1/16 inch (1.6 mm), the brake shoes should be replaced.
- Inspect the backing plate and other components for signs of excessive wear or deformation. If any deformation is found, the appropriate components must be replaced.
- Check the brake fluid level; refer to Checking the Brake Fluid Level.

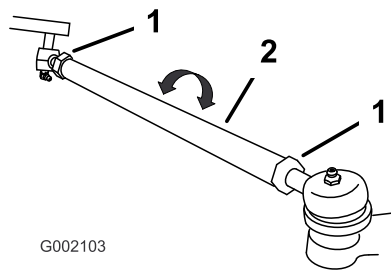

Figure 34

1. Jam nut
2. Tie rod

5. Rotate both tie rods to move the front of the tire inward or outward.
6. Tighten the tie rod jam nuts when the adjustment is correct.
7. Ensure that there is full travel of the steering wheel in both directions.

Checking the Transaxle Oil Level

Service Interval: Every 100 hours

Every 800 hours

Check the oil level in the transaxle at the rear of the vehicle every 100 operating hours. Change the oil in the transaxle every 800 operating hours.

1. Park the vehicle on a level surface, set the parking brake, and turn off and remove the key.
2. Remove the check bolt on the transaxle (Figure 35).

The oil level should be even with the bottom of the check hole.

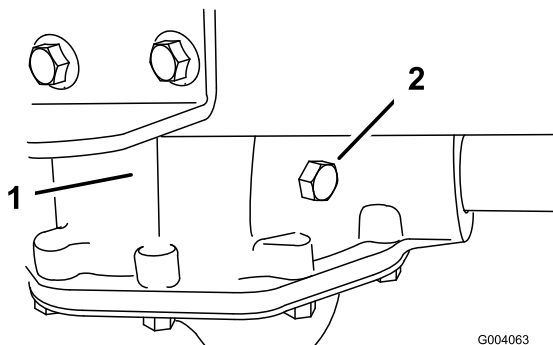

Figure 35

1. Transaxle
2. Check bolt

3. If the oil level is low, add 10w30 motor oil to the check hole until it runs out the hole.
4. Replace the check bolt and torque it to 15 to 20 ft-lb (20 to 27 N-m).

Checking the Brake Fluid Level

Service Interval: Before each use or daily

The brake fluid reservoir is filled and shipped from the factory with DOT 3 brake fluid. Check the level before the vehicle is first started and every 8 hours or daily, thereafter.

1. Park the machine on a level surface, set the parking brake, turn the On/Off switch to Off, and remove the key.
2. Remove the rubber plug in the center and on top of the dash to gain access to the master brake cylinder and reservoir.
3. Look at the side of the reservoir. The level should be above the Minimum line (Figure 36). If the fluid level is low, clean the area around the cap, remove the cap, and fill the reservoir to above the Minimum line. Do not overfill.

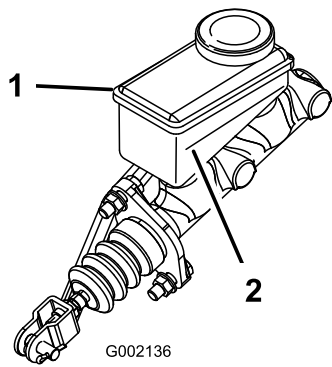

G002136

Figure 36

1. Brake fluid reservoir 2. Minimum line

Cleaning

Washing the Vehicle

The vehicle should be washed as needed. Use water alone or with a mild detergent. A rag may be used, however the hood will lose some of its luster.

Important: Pressurized water is not recommended when washing the machine. It may damage the electrical system, loosen important decals, or wash away necessary grease at friction points. Avoid excessive use of water, especially near the control panel, motor, and batteries.

Adjusting the Parking Brake

Check the parking brake adjustment every 200 hours.

1. Pry the rubber cover off of the parking brake.
2. Loosen the set screw securing the knob to the parking brake lever (Figure 37).

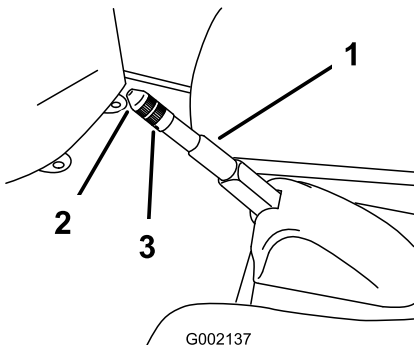

G002137

Figure 37

1. Parking brake lever 3. Set screw
2. Knob

3. Rotate the knob until a force of 30-35 lb (133-156 N) is required to actuate the lever.
4. Tighten the set screw and install the rubber cover.

Storage

1. Position the machine on a level surface, set the parking brake, stop the vehicle, and remove the key.
2. Clean dirt and grime from the entire machine, including the outside of the motor housing.

Important: You can wash the machine with mild detergent and water. Do not use high pressure water to wash the machine. Pressure washing may damage the electrical system or wash away necessary grease at friction points. Avoid excessive use of water, especially near the control panel, lights, motor, and the battery.

3. Inspect the brakes; refer to Inspecting the Brakes in the Brake Maintenance section in Maintenance.
4. Grease the machine; refer to Lubrication section in Maintenance.
5. Check the tire pressure; refer to Checking the Tire Pressure.
6. Charge the batteries fully before placing the vehicle into storage, refer to Maintaining the Batteries section in Electrical System Maintenance. Plug the charger into a wall outlet while the vehicle and batteries are in storage. Leave the charger plugged into a wall outlet and charging receptacle during storage to ensure that the batteries stay charged and do not freeze; otherwise, charge the batteries at least once every 3 months.
7. Check and tighten all bolts, nuts, and screws. Repair or replace any part that is damaged.
8. Paint all scratched or bare metal surfaces.
Paint is available from your Authorized Service Dealer.
9. Store the machine in a clean, dry garage or storage area.
10. Remove the key and put it in a safe place out of the reach of children.
11. Cover the machine to protect it and keep it clean.

Troubleshooting

Vehicle Status Light Flash Pattern

Problem	Possible Cause	Corrective Action
Always on	1. The system is functioning properly.	1. None
1 flash	1. The computer programming personality is out of range.	1. Turn the On/Off key to the Off position, wait a few seconds, and turn the On/Off key to the On position. If the condition continues, refer to your Authorized Service Dealer.
2 flashes	1. The accelerator pedal was pressed when the On/Off key was turned.	1. Turn the On/Off key to the Off position, release the accelerator pedal, and turn the On/Off key to the On position.
3 flashes	1. The power block has a short circuit (MOSFET S/C). 2. A poor batter or power cable connection.	1. Turn the On/Off key to the Off position, wait a few seconds, and turn the On/Off key to the On position. Check all batteries and high current controller connections. If the condition continues, refer to your Authorized Service Dealer. 2. Turn the On/Off key to the Off position, wait a few seconds, and turn the On/Off key to the On position. Check all batteries and high current controller connections. If the condition continues, refer to your Authorized Service Dealer.
4 flashes	1. The line contactor is not responding to commands.	1. Turn the On/Off key to the Off position, wait a few seconds, and turn the On/Off key to the On position. If the condition continues, refer to your Authorized Service Dealer.
5 flashes	1. The charger interlock switch is active.	1. Turn the On/Off key to the Off position, disconnect the charger, and turn the On/Off key to the On position.
6 flashes	1. Accelerator potentiometer is out of adjustment.	1. Refer to your Authorized Service Dealer.
7 flashes	1. Battery voltage is out of range. 2. Over voltage error code caused by overspeeding when traveling down a steep hill.	1. Refer to your Authorized Service Dealer. 2. Cycle pedal to clear fault, if not refer to your Authorized Service Dealer to have the batteries tested and replaced if necessary.
8 flashes	1. The controller is overheated.	1. The vehicle will continue to run, but at reduced power until the controller cools down.
9 flashes	1. The motor is over heated or the battery is nearly discharged (the vehicle will go into the energy saving mode).	1. If the batter meter displays more than one bar, stop the vehicle and allow the motor to cool before operating it again. If the battery meter displays only one bar, charge the vehicle immediately.
Off	1. No power to the controller or the controller has failed.	1. Refer to your Authorized Service Dealer.

Schematics

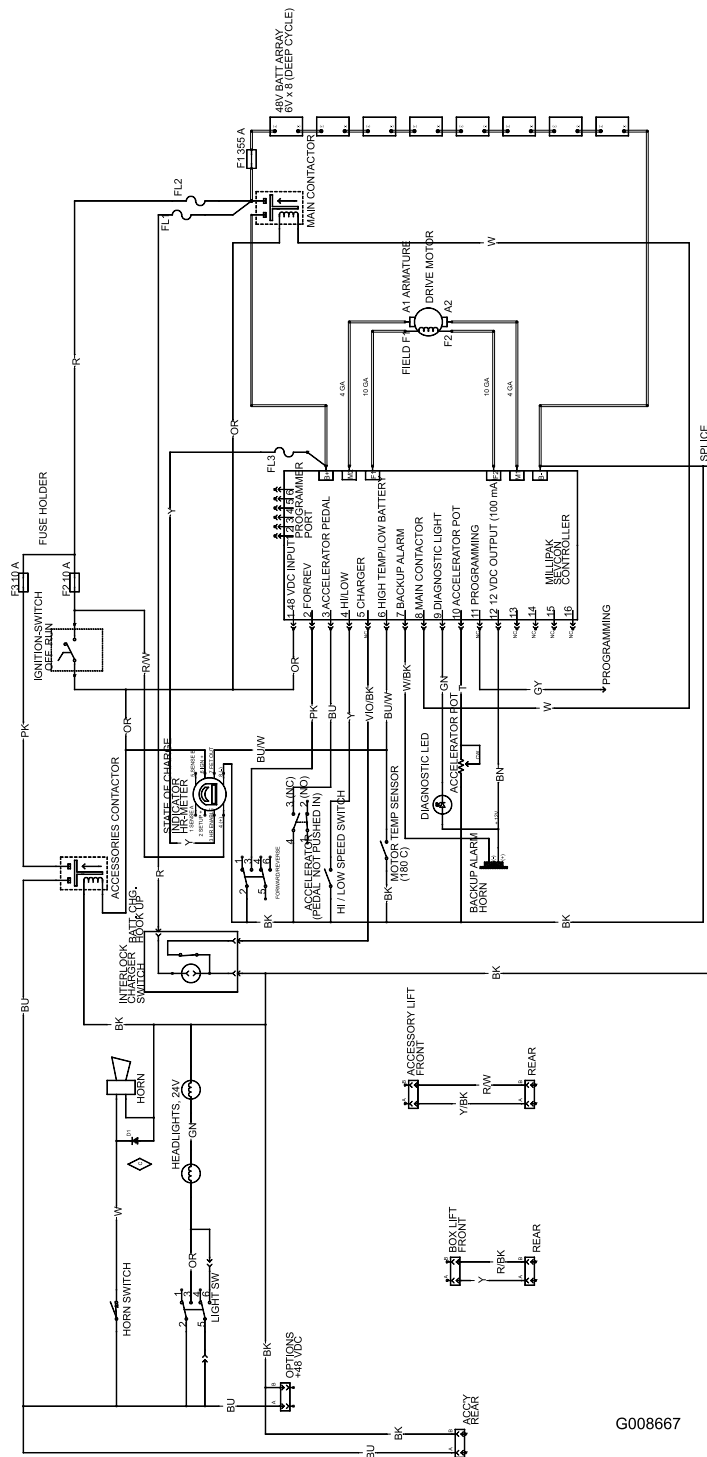

G008667

Electrical Schematic (Rev. C)

Notes:

Notes:



The Toro General Commercial products Guarantee

A Limited Warranty

Electric
Workman

Conditions and Products Covered

The Toro Company and its affiliate, Toro Warranty Company, pursuant to an agreement between them, jointly warrant your Toro Commercial product ("Product") to be free from defects in materials or workmanship for two years or 1500 operational hours*, whichever occurs first. Where a warrantable condition exists, we will repair the Product at no cost to you including diagnostics, labor, parts, and transportation. This warranty begins on the date the Product is delivered to the original retail purchaser.

* Product equipped with an hour meter.

Instructions for Obtaining Warranty Service

You are responsible for notifying the Commercial Products Distributor or Authorized Commercial Products Dealer from whom you purchased the Product as soon as you believe a warrantable condition exists. If you need help locating a Commercial Products Distributor or Authorized Dealer, or if you have questions regarding your warranty rights or responsibilities, you may contact us at:

Commercial Products Service Department
Toro Warranty Company
8111 Lyndale Avenue South
Bloomington, MN 55420-1196
E-mail: commercial.warranty@toro.com

Owner Responsibilities

As the Product owner, you are responsible for required maintenance and adjustments stated in your *Operator's Manual*. Failure to perform required maintenance and adjustments can be grounds for disallowing a warranty claim.

Items and Conditions Not Covered

Not all product failures or malfunctions that occur during the warranty period are defects in materials or workmanship. This warranty does not cover the following:

- Product failures which result from the use of non-Toro replacement parts, or from installation and use of add-on, or modified non-Toro branded accessories and products. A separate warranty may be provided by the manufacturer of these items.
- Product failures which result from failure to perform recommended maintenance and/or adjustments. Failure to properly maintain your Toro product per the Recommended Maintenance listed in the *Operator's Manual* can result in claims for warranty being denied.
- Product failures which result from operating the Product in an abusive, negligent or reckless manner.

Countries Other than the United States or Canada

Customers who have purchased Toro products exported from the United States or Canada should contact their Toro Distributor (Dealer) to obtain guarantee policies for your country, province, or state. If for any reason you are dissatisfied with your Distributor's service or have difficulty obtaining guarantee information, contact the Toro importer. If all other remedies fail, you may contact us at Toro Warranty Company.

- Parts subject to consumption through use unless found to be defective. Examples of parts which are consumed, or used up, during normal Product operation include, but are not limited to, batteries, carbon brushes, brake components, tires, filters, belts, etc.
- Failures caused by outside influence. Items considered to be outside influence include, but are not limited to, weather, storage practices, contamination, use of unapproved lubricants, additives, chemicals, etc.
- Normal "wear and tear" items. Normal "wear and tear" includes, but is not limited to, damage to seats due to wear or abrasion, worn painted surfaces, scratched decals or windows, etc.

Parts

Parts scheduled for replacement as required maintenance are warranted for the period of time up to the scheduled replacement time for that part. Parts replaced under this warranty are covered for the duration of the original product warranty and become the property of Toro. Toro will make the final decision whether to repair any existing part or assembly or replace it. Toro may use remanufactured parts for warranty repairs.

Note Regarding Deep Cycle Battery Warranty:

Deep cycle batteries have a specified total number of kilowatt-hours they can deliver during their lifetime. Operating, recharging, and maintenance techniques can extend or reduce total battery life. As the batteries in this product are consumed, the amount of useful work between charging intervals will slowly decrease until the battery is completely worn out. Replacement of worn out batteries, due to normal consumption, is the responsibility of the product owner. Battery replacement may be required during the normal product warranty period at owner's expense.

General Conditions

Repair by an Authorized Toro Distributor or Dealer is your sole remedy under this warranty.

Neither The Toro Company nor Toro Warranty Company is liable for indirect, incidental or consequential damages in connection with the use of the Toro Products covered by this warranty, including any cost or expense of providing substitute equipment or service during reasonable periods of malfunction or non-use pending completion of repairs under this warranty.

All implied warranties of merchantability and fitness for use are limited to the duration of this express warranty. Some states do not allow exclusions of incidental or consequential damages, or limitations on how long an implied warranty lasts, so the above exclusions and limitations may not apply to you.

This warranty gives you specific legal rights, and you may also have other rights which vary from state to state.