



**Count on it.**

**Operator's Manual**

**Groundsmaster® 5900 and 5910  
Rotary Mower**

Model No. 31598—Serial No. 313000301 and Up

Model No. 31598TE—Serial No. 313000301 and Up

Model No. 31599—Serial No. 313000301 and Up

Model No. 31599TE—Serial No. 313000301 and Up



This product complies with all relevant European directives, for details please see the separate product specific Declaration of Conformity (DOC) sheet

your product ready. Figure 1 identifies the location of the model and serial numbers on the product. Write the numbers in the space provided.

**▲ WARNING**

**CALIFORNIA**  
**Proposition 65 Warning**

**This product contains a chemical or chemicals known to the State of California to cause cancer, birth defects, or reproductive harm.**

**Diesel engine exhaust and some of its constituents are known to the State of California to cause cancer, birth defects, and other reproductive harm.**

Because in some areas there are local, state, or federal regulations requiring that a spark arrester be used on the engine of this machine, a spark arrester is incorporated with the muffler assembly.

Genuine Toro spark arresters are approved by the USDA Forestry Service.

**Important:** This engine is equipped with a spark arrester muffler. It is a violation of California Public Resource Code Section 4442 to use or operate the engine on any forest-covered, brush-covered, or grass-covered land without a spark arrester muffler maintained in working order, or the engine constricted, equipped, and maintained for the prevention of fire. Other states or federal areas may have similar laws.

## Introduction

This machine is a ride-on, rotary-blade lawn mower intended to be used by professional, hired operators in commercial applications. It is primarily designed for cutting grass on well-maintained lawns in parks, golf courses, sports fields, and on commercial grounds. It is not designed for cutting brush, mowing grass and other growth alongside highways, or for agricultural uses.

Read this information carefully to learn how to operate and maintain your product properly and to avoid injury and product damage. You are responsible for operating the product properly and safely.

You may contact Toro directly at [www.Toro.com](http://www.Toro.com) for product and accessory information, help finding a dealer, or to register your product.

Whenever you need service, genuine Toro parts, or additional information, contact an Authorized Service Dealer or Toro Customer Service and have the model and serial numbers of

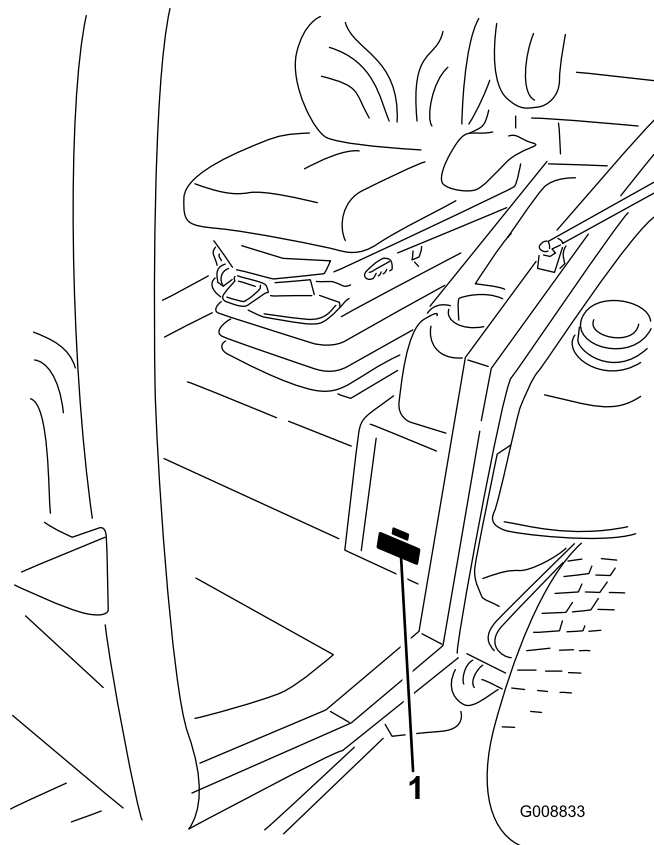

Figure 1

1. Model and serial number location

Model No. _____
Serial No. _____

This manual identifies potential hazards and has safety messages identified by the safety alert symbol (Figure 2), which signals a hazard that may cause serious injury or death if you do not follow the recommended precautions.



Figure 2

1. Safety alert symbol

This manual uses 2 other words to highlight information. **Important** calls attention to special mechanical information and **Note** emphasizes general information worthy of special attention.

# Contents

Safety .....	4	Servicing the Fuel System .....	44
Safe Operating Practices .....	4	Servicing the Water Separator .....	44
Toro Mower Safety .....	6	Replacing the Fuel Filter .....	45
Sound Power Level .....	7	Electrical System Maintenance .....	46
Sound Pressure Level .....	7	Fuses .....	46
Sound Pressure Level .....	7	Battery Care .....	47
Vibration Level .....	7	Jump Starting / Battery Charging .....	47
Safety and Instructional Decals .....	8	Recalibrate Traction Pedal .....	47
Setup .....	15	Drive System Maintenance .....	48
1 Remove Side Deck Shipping Strap and		Adjusting the Traction Pedal Angle .....	48
Brace .....	15	Checking the Planetary Drive Gear/Brake	
2 Lower Front Deck Winglets .....	15	Oil .....	48
3 Level Front Center Deck .....	17	Changing the Planetary Drive Gear/Brake	
4 Level Winglet Decks to Front Center		Oil .....	48
Deck .....	17	Checking the Rear Wheel Toe-In .....	49
5 Checking Tire Pressure .....	18	Cooling System Maintenance .....	50
6 Checking Fluid Levels .....	18	Checking the Cooling System .....	50
7 Greasing Machine .....	18	Servicing the Engine Cooling System .....	51
Product Overview .....	19	Brake Maintenance .....	51
Controls .....	19	Adjusting the Service Brakes .....	51
Specifications .....	25	Belt Maintenance .....	52
Attachments/Accessories .....	25	Servicing the Alternator Belt .....	52
Operation .....	26	Servicing the Compressor Belt .....	52
Checking the Engine Oil Level .....	26	Replacing the Blade Drive Belts .....	52
Checking the Cooling System .....	26	Front Cutting Unit .....	52
Checking the Hydraulic System .....	26	Side Cutting Decks .....	53
Adding Fuel .....	26	Hydraulic System Maintenance .....	54
Checking the Tire Pressure .....	27	Checking the Hydraulic Fluid .....	54
Checking the Torque of Wheel Lug Nuts .....	27	Changing the Hydraulic Fluid and Filters .....	55
Adjusting the Height-of-Cut .....	27	Checking the Hydraulic Lines and Hoses .....	55
Adjusting the Skids .....	30	Hydraulic System Test Ports .....	55
Adjusting the Cutting Unit Anti-Scalp Rollers .....	30	Mower Maintenance .....	56
Checking the Mismatch Between Cutting		Pivoting (Tilting) the Front Cutting Unit	
Units .....	31	Upright .....	56
Adjusting the Mirrors .....	32	Pivoting the Front Cutting Unit Down .....	56
Aiming the Headlights .....	32	Adjusting the Cutting Unit Pitch .....	57
Starting and Stopping the Engine .....	32	Servicing the Castor Arm Bushings .....	58
Checking the Interlock Switches .....	33	Servicing the Castor Wheels and Bearings .....	58
Pushing or Towing the Machine .....	33	Blade Maintenance .....	59
Jacking Points .....	34	Checking for a Bent Blade .....	59
Tie Downs .....	34	Removing and Installing the Cutter Blade(s) .....	59
Operating Characteristics .....	35	Inspecting and Sharpening the Cutter Blade(s) .....	59
Reversing Fan Operation .....	35	Correcting the Cutting Unit Mismatch .....	60
Operating Tips .....	36	Miscellaneous Maintenance .....	61
Maintenance .....	37	Servicing the Spark Arrestor Muffler .....	61
Recommended Maintenance Schedule(s) .....	37	Cleaning the Cab Air Filters .....	61
Service Interval Chart .....	38	Cleaning the Air Conditioning Coil .....	61
Pre-maintenance Procedures .....	38	Cleaning the A/C Condenser Screen .....	62
Inner Wing Deck Covers .....	38	Storage .....	63
Lubrication .....	39	Preparing for Seasonal Storage .....	63
Greasing the Bearings and Bushings .....	39	Schematics .....	64
Engine Maintenance .....	42		
Air Cleaner Maintenance .....	42		
Servicing the Engine Oil .....	43		
Adjusting the Valve Clearance .....	44		
Fuel System Maintenance .....	44		

# Safety

This machine meets or exceeds CEN standard EN 836:1997, ISO standard 5395:1990, and ANSI B71.4-2004 specifications in effect at the time of production.

Improper use or maintenance by the operator or owner can result in injury. To reduce the potential for injury, comply with these safety instructions and always pay attention to the safety alert symbol, which means **Caution, Warning, or Danger**—personal safety instruction. Failure to comply with the instruction may result in personal injury or death.

## Safe Operating Practices

The following instructions are from the CEN standard EN 836:1997, ISO standard 5395:1990, and ANSI standard B71.4-2004.

### Training

- Read the *Operator's Manual* and other training material carefully. Be familiar with the controls, safety signs, and the proper use of the equipment.
- Never allow children or people unfamiliar with these instructions to use the mower. Local regulations may restrict the age of the operator.
- Never mow while people, especially children, or pets are nearby.
- Keep in mind that the operator or user is responsible for accidents or hazards occurring to himself or herself, other people, or property.
- Do not carry passengers.
- All drivers and mechanics should seek and obtain professional and practical instruction. The owner is responsible for training the users. Such instruction should emphasize:
  - the need for care and concentration when working with ride-on machines;
  - control of a ride-on machine sliding on a slope will not be regained by the application of the brake. The main reasons for loss of control are:
    - ◇ insufficient wheel grip;
    - ◇ being driven too fast;
    - ◇ inadequate braking;
    - ◇ the type of machine is unsuitable for its task;
    - ◇ lack of awareness of the effect of ground conditions, especially slopes;
    - ◇ incorrect hitching and load distribution.

### Preparation

- While mowing, always wear substantial footwear, long trousers, hard hat, safety glasses, and ear protection. Long

hair, loose clothing or jewelry may get tangled in moving parts. Do not operate the equipment when barefoot or wearing open sandals.

- Thoroughly inspect the area where the equipment is to be used and remove all objects which may be thrown by the machine.
- **Warning**—fuel is highly flammable. Take the following precautions:
  - Store fuel in containers specifically designed for this purpose.
  - Refuel outdoors only and do not smoke while refuelling.
  - Add fuel before starting the engine. Never remove the cap of the fuel tank or add fuel while the engine is running or when the engine is hot.
  - If fuel is spilled, do not attempt to start the engine but move the machine away from the area of spillage and avoid creating any source of ignition until fuel vapors have dissipated.
  - Replace all fuel tank and container caps securely.
- Replace faulty silencers/mufflers.
- Before using, always visually inspect to see that the blades, blade bolts, and cutting assembly are not worn or damaged. Replace worn or damaged blades and bolts in sets to preserve balance.
- Evaluate the terrain to determine what accessories and attachments are needed to properly and safely perform the job. Only use accessories and attachments approved by the manufacturer.
- Check that operators presence controls, safety switches, and shields are attached and functioning properly. Do not operate unless they are functioning properly.

### Operation

- Do not operate the engine in a confined space where dangerous carbon monoxide fumes can collect.
- Mow only in daylight or in good artificial light.
- Before attempting to start the engine, disengage the PTO, shift into neutral, and engage the parking brake. Only start the engine from the operators position. Use seat belts, if provided.
- Remember there is no such thing as a safe slope. Travel on grass slopes requires particular care. To guard against overturning:
  - Do not stop or start suddenly when going up or downhill.
  - The machine speed should be kept low on slopes and during tight turns.
  - Stay alert for humps and hollows and other hidden hazards.
  - Never mow across the face of the slope, unless the machine is designed for that purpose.

- Stay alert for holes in the terrain and other hidden hazards.
- Use care when using heavy equipment.
  - Do not turn sharply. Use care when reversing.
  - Use counterweight(s) or wheel weights when suggested in the *Operator's Manual*.
- Watch out for traffic when crossing or near roadways.
- Stop the blades from rotating before crossing surfaces other than grass.
- When using any attachments, never direct discharge of material toward bystanders nor allow anyone near the machine while in operation.
- Never operate the machine with damaged guards, shields, or without safety protective devices in place. Be sure all interlocks are attached, adjusted properly, and functioning properly.
- Do not change the engine governor settings or overspeed the engine. Operating the engine at excessive speed may increase the hazard of personal injury.
- Before leaving the operators position:
  - Stop on level ground.
  - Disengage the power take-off and lower the attachments.
  - Change into neutral and set the parking brake.
  - Stop the engine and remove the key.
- Disengage drive to attachments, stop the engine and remove the ignition key:
  - before clearing blockages;
  - before checking, cleaning, or working on the machine;
  - after striking a foreign object. Inspect the machine for damage and make repairs before restarting and operating the equipment. Torque all the spindle pulley nuts to 130 to 150 ft-lb (176 to 203 N·m) and all the blade bolts to 85 to 110 ft-lb (115 to 149 N·m),
  - if the machine starts to vibrate abnormally (check immediately).
- Disengage drive to attachments when transporting or not in use.
- Stop the engine and disengage drive to attachment:
  - before refuelling;
  - before making height adjustment unless adjustment can be made from the operators position.
- Reduce the throttle setting before stopping engine and, if the engine is provided with a fuel shut-off valve, turn the fuel off at the conclusion of mowing.
- Never raise deck with the blades running.
- Keep hands and feet away from the cutting units.
- Look behind and down before backing up to be sure of a clear path.
- Slow down and use caution when making turns and crossing roads and sidewalks.
- Do not operate the mower under the influence of alcohol or drugs.
- Lightning can cause severe injury or death. If lightning is seen or thunder is heard in the area, do not operate the machine; seek shelter.
- Use care when loading or unloading the machine into a trailer or truck.
- The operator shall turn on flashing warning lights whenever traveling on a public road, except where such use is prohibited by law.

## Maintenance and Storage

- Keep all nuts, bolts, and screws tight to be sure the equipment is in safe working condition.
- Never store the equipment with fuel in the tank inside a building where fumes may reach an open flame or spark.
- Allow the engine to cool before storing in any enclosure and do not store near flame.
- To reduce the fire hazard, keep the engine compartment, silencer/muffler, battery compartment, cutting units, drives, and fuel storage area free of grass, leaves, or excessive grease. Clean up oil or fuel spillage.
- Replace worn or damaged parts for safety.
- If the fuel tank has to be drained, do this outdoors.
- On multi-bladed machines, take care as rotating one blade can cause other blades to rotate.
- When machine is to be parked, stored, or left unattended, lower the cutting units unless a positive mechanical lock is provided.
- Disengage drives, lower the cutting units, move traction pedal to Neutral, set parking brake, move the throttle switch to the low idle position, stop engine and remove ignition key. Wait for all movement to stop before adjusting, cleaning or repairing.
- Shut off fuel while storing or transporting. Do not store fuel near flames.
- Park machine on level ground. Never allow untrained personnel to service machine.
- Use jack stands to support components when required.
- Carefully release pressure from components with stored energy.
- Disconnect battery before making any repairs. Disconnect the negative terminal first and the positive last. Reconnect positive first and negative last.
- Use care when checking blades. Wrap the blades or wear gloves, and use caution when servicing them. Only replace blades. Never straighten or weld them.
- Keep hands and feet away from moving parts. If possible, do not make adjustments with the engine running.
- Charge batteries in an open well ventilated area, away from spark and flames. Unplug charger before connecting or disconnecting from battery. Wear protective clothing and use insulated tools.

- Make sure all hydraulic line connectors are tight and all hydraulic hoses and lines are in good condition before applying pressure to the system.
- Keep your body and hands away from pin hole leaks or nozzles that eject hydraulic fluid under high pressure. Use paper or cardboard, not your hands, to search for leaks. Hydraulic fluid escaping under pressure can have sufficient force to penetrate the skin and cause serious injury. If fluid is injected into the skin it must be surgically removed within a few hours by a doctor familiar with this form of injury or gangrene may result.
- Always wear the seat belt when operating the machine.
- Be certain that the seat belt can be released quickly if the machine is driven or rolls into a pond or water.
- Watch for traffic when near or crossing roads. Always yield the right-of-way.
- Do not mow near drop-offs, ditches, or embankments. The machine could suddenly turn over if a wheel goes over the edge of a cliff or ditch or if an edge gives way.
- Do not mow on wet grass. Reduced traction could cause sliding.
- Machine should not be used as a tow vehicle.
- Use extra care with other attachments. These can change the stability of the machine.
- Turn off the blades when not mowing.
- For operating environments exceeding 110 degrees F (43 degrees C), consult Toro for special machine needs.
- Do not operate the engine below 1350 rpm.

## Toro Mower Safety

The following list contains safety information specific to Toro products or other safety information that you must know that is not included in the CEN, ISO, or ANSI standards.

This product is capable of amputating hands and feet and throwing objects. Always follow all safety instructions to avoid serious injury or death.

Use of this product for purposes other than its intended use could prove dangerous to user and bystanders.

### Operation

- Before operating the machine be certain that the seat belts are attached.
- Know how to stop the machine and engine quickly.
- Do not operate the machine while wearing tennis shoes or sneakers.
- Wearing safety shoes and long pants is advisable and required by some local ordinances and insurance regulations.
- Keep hands, feet, and clothing away from moving parts and the mower discharge area and underside of the mower while the engine is running.
- Fill fuel tank until level is 1 inch (25 mm) below the bottom of the filler neck. Do not overfill.
- Check the safety interlock switches daily for proper operation. If a switch should fail, replace the switch before operating the machine.
- Check carefully for overhead clearances (i.e. branches, doorways, electrical wires) before driving under any objects and do not contact them.
- Do not mow in reverse unless absolutely necessary.
- Reduce speed when making sharp turns.
- Avoid starting or stopping on a slope. If tires lose traction, disengage the blades and proceed slowly straight down the slope. Avoid raising the side cutting units on a slope.
- Avoid turning on slopes. If you must turn, turn slowly and gradually downhill, if possible.
- Never remove the ROPS from the machine.

### Maintenance and Storage

- Do not touch equipment or attachment parts which may be hot from operation. Allow to cool before attempting to maintain, adjust, or service.
- Never store the machine or fuel container inside where there is an open flame, such as near a water heater or furnace.
- Keep nuts and bolts tight, especially the blade attachment bolts. Keep equipment in good condition.
- If the engine must be running to perform a maintenance adjustment, keep hands, feet, clothing, and any parts of the body away from the cutting units, attachments, and any moving parts. Keep everyone away.
- Check brake operation frequently. Adjust and service as required.
- Battery acid is poisonous and can cause burns. Avoid contact with skin, eyes, and clothing. Protect your face, eyes, and clothing when working with a battery.
- Battery gases can explode. Keep cigarettes, sparks, and flames away from the battery.
- Do not use high pressure water near Info Center.
- The engine must be shut off before checking the oil or adding oil to the crankcase.
- If major repairs are ever needed or if assistance is desired, contact an Authorized Toro Distributor.
- To make sure of optimum performance and continued safety certification of the machine, use only genuine Toro replacement parts and accessories. Replacement parts and accessories made by other manufacturers could be dangerous, and such use could void the product warranty.

## Sound Power Level

This unit has a guaranteed sound power level of 105 dBA, which includes an Uncertainty Value (K) of 1 dBA.

Sound power level was determined according to the procedures outlined in ISO 11094.

## Sound Pressure Level

### Model 31598

This unit has a sound pressure level at the operator's ear of 92 dBA, which includes an Uncertainty Value (K) of 1 dBA.

Sound pressure level was determined according to the procedures outlined in EN 836.

## Sound Pressure Level

### Model 31599

This unit has a sound pressure level at the operator's ear of 84 dBA, which includes an Uncertainty Value (K) of 1 dBA.

Sound pressure level was determined according to the procedures outlined in EN 836.

## Vibration Level

### Hand-Arm

Measured vibration level for right hand = 0.63 m/s<sup>2</sup>

Measured vibration level for left hand = 0.65 m/s<sup>2</sup>

Uncertainty Value (K) = 0.5 m/s<sup>2</sup>

Measured values were determined according to the procedures outlined in EN 836.

### Whole Body

Measured vibration level = 0.58 m/s<sup>2</sup>

Uncertainty Value (K) = 0.5 m/s<sup>2</sup>

Measured values were determined according to the procedures outlined in EN 836.

# Safety and Instructional Decals



Safety decals and instructions are easily visible to the operator and are located near any area of potential danger. Replace any decal that is damaged or lost.

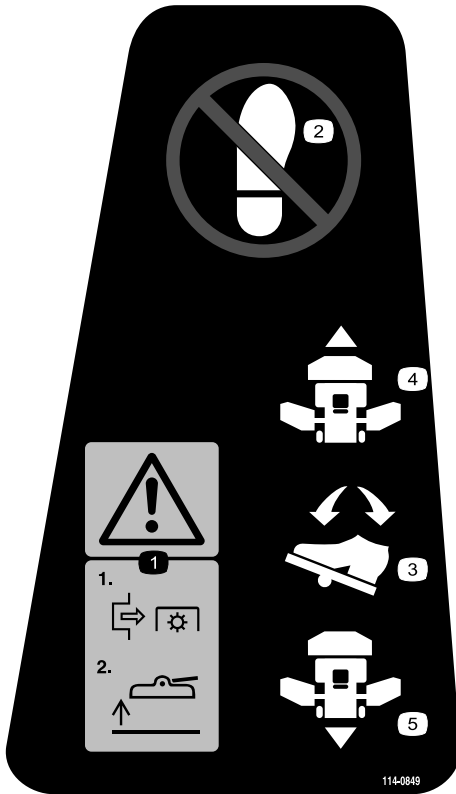

**114-0849**

1. Warning—disengage the PTO then raise the deck.
2. No step
3. Traction control pedal
4. Forward
5. Reverse

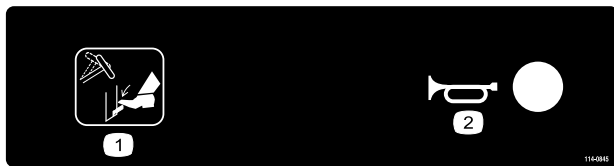

**114-0845**

1. Tilt steering lever
2. Horn

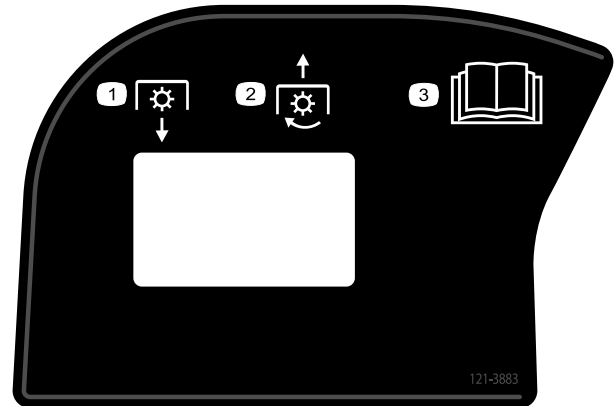

**121-3883**

1. Disengage the PTO
2. Engage the PTO
3. Read the *Operator's Manual*

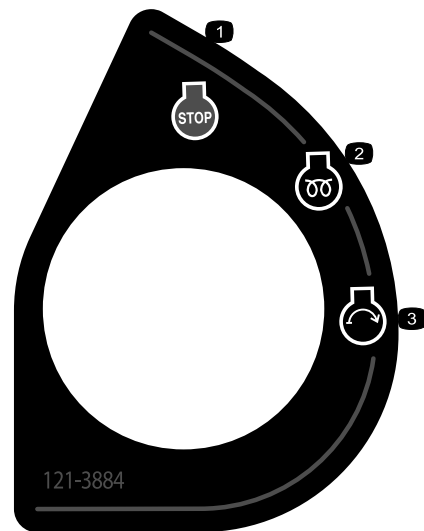

**121-3884**

1. Engine—stop
2. Engine—preheat
3. Engine—start

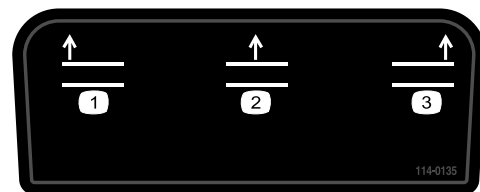

**114-0135**

1. Raise cutting units—left
2. Raise cutting units—center
3. Raise cutting units—right

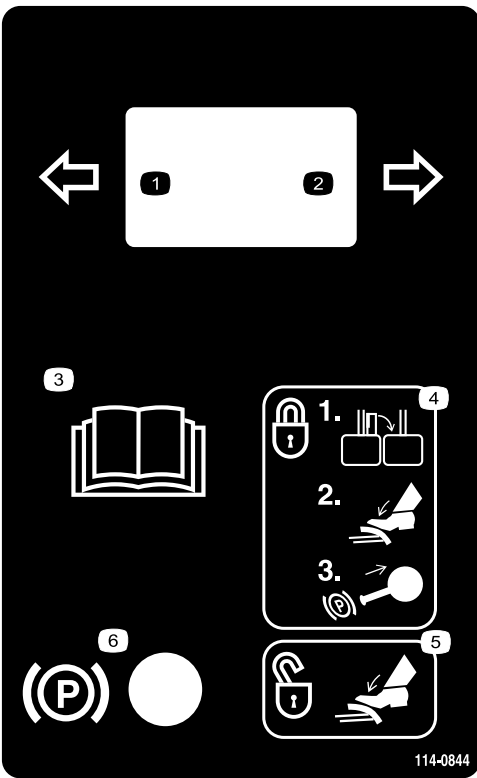

114-0844

- |                                       |  |
|---------------------------------------|--|
| 1. Left hand turn signal              | 4. To lock the brakes, close latch, press the brake pedal and pull up on the parking brake knob. |
| 2. Right hand turn signal             | 5. To unlock the parking brake, press the brake.   |
| 3. Read the <i>Operators Manual</i> . | 6. Parking brake   |



115-5459

1. Electric shock hazard—do not remove cover; keep cover in place.

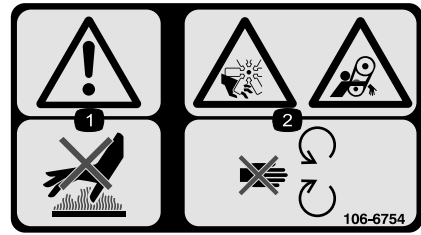

106-6754

1. Warning—do not touch the hot surface.
2. Cutting/dismemberment hazard, fan and entanglement hazard, belt—stay away from moving parts.

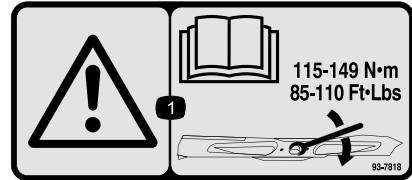

93-7818

1. Warning—read the *Operator's Manual* for instructions on torquing the blade bolt/nut to 115-149 N-m (85-110 ft-lb).

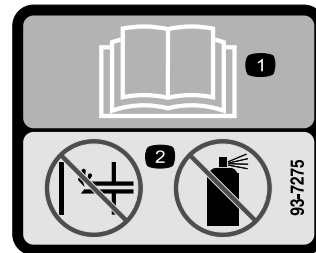

93-7275

1. Read the *Operator's Manual*—do not use starting fluid to start the engine.



106-6755

- |   |  |
|---|--|
| 1. Engine coolant under pressure.                       | 3. Warning—do not touch the hot surface.       |
| 2. Explosion hazard—read the <i>Operator's Manual</i> . | 4. Warning—read the <i>Operator's Manual</i> . |

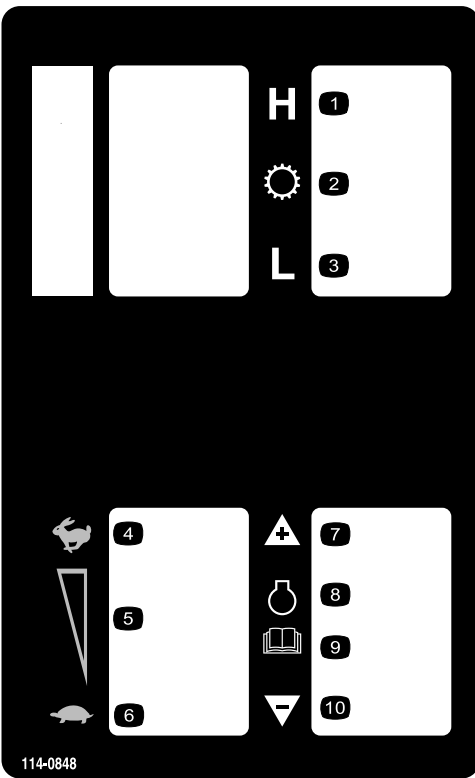

114-0848

- |                 |  |
|-----------------|--|
| 1. High range   | 6. Low idle                            |
| 2. Transmission | 7. Increase engine speed               |
| 3. Low range    | 8. Engine                              |
| 4. High idle    | 9. Read the <i>Operator's Manual</i> . |
| 5. Mid idle     | 10. Decrease engine speed              |

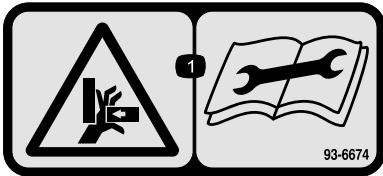

93-6674

- Crushing hazard, hand—read the instructions before servicing or performing maintenance.



93-6687

- Do not step here.

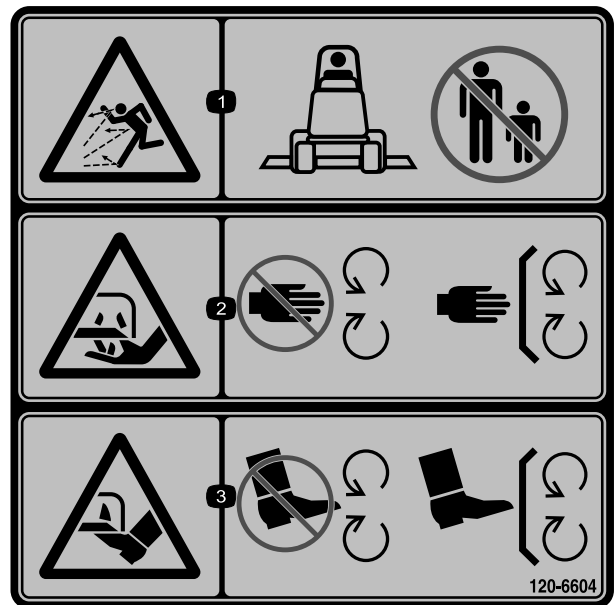

120-6604

- Thrown object hazard—keep bystanders away from the machine.
- Cutting/dismemberment hazard of hand, mower blade—stay away from moving parts, keep all guards and shields in place.
- Cutting/dismemberment hazard of foot, mower blade—stay away from moving parts, keep all guards and shields in place.

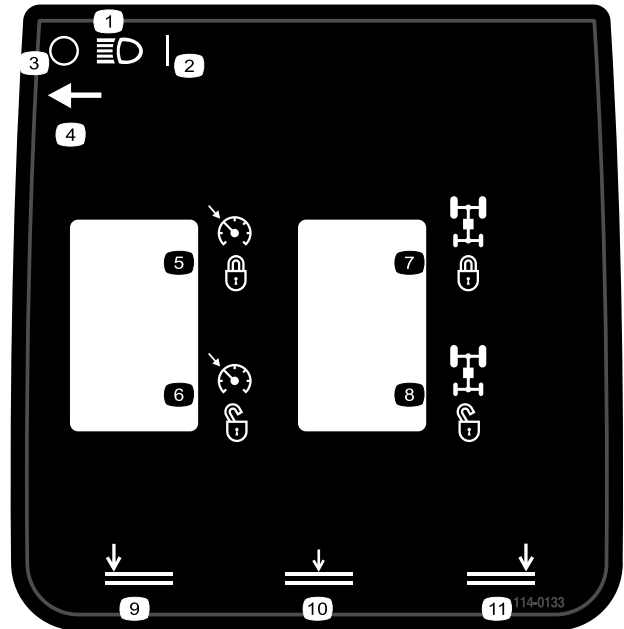

114-0133

- |                              |                                |
|------------------------------|--------------------------------|
| 1. Headlights                | 7. Flow divider—engage         |
| 2. On                        | 8. Flow divider—disengage      |
| 3. Off                       | 9. Lower cutting units—left    |
| 4. Headlight switch location | 10. Lower cutting units—center |
| 5. Cruise control—engage     | 11. Lower cutting units—right  |
| 6. Cruise control—disengage  |                                |

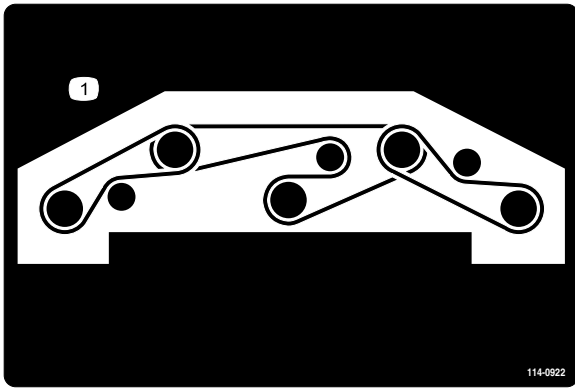

114-0922

1. Belt routing

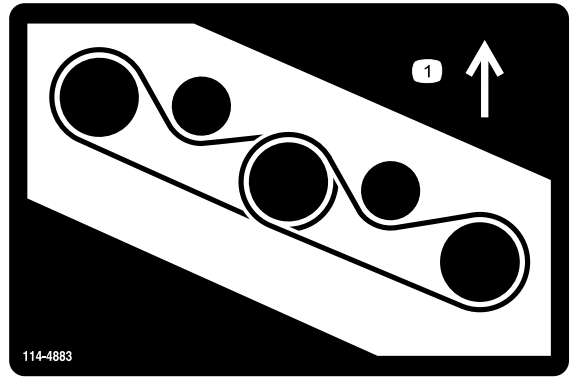

114-4883

1. Belt routing

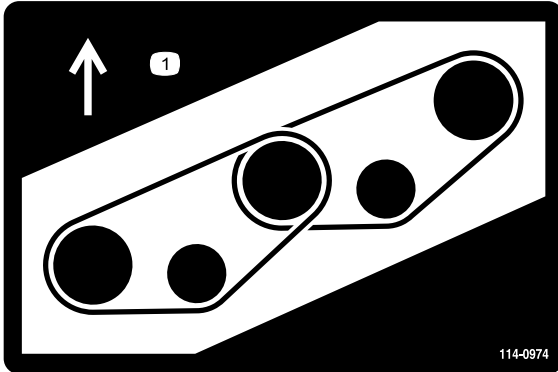

114-0974

1. Belt routing

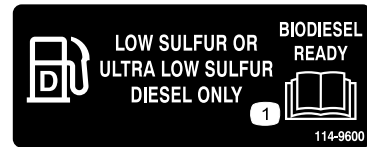

114-9600

1. Read the *Operator's Manual*.



117-2718

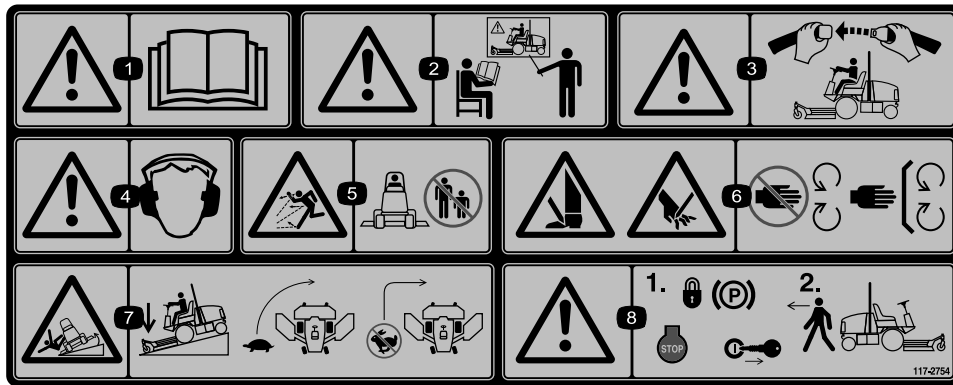

117-2754

1. Warning—read the *Operator's Manual*.
2. Warning—do not operate this machine unless you are trained.
3. Warning—wear the seat belt when seated in the operator's position.
4. Warning—wear hearing protection.
5. Thrown object hazard—keep bystanders a safe distance from the machine.
6. Cutting hazard of hand or foot—stay away from moving parts; keep all guards in place.
7. Tipping hazard—lower the cutting unit when driving down slopes; slow machine before turning, do not turn at high speeds
8. Warning—lock the parking brake, stop the engine and remove the ignition key before leaving the machine.

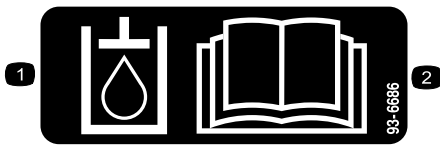

93-6686

1. Hydraulic oil
2. Read the *Operator's Manual*.

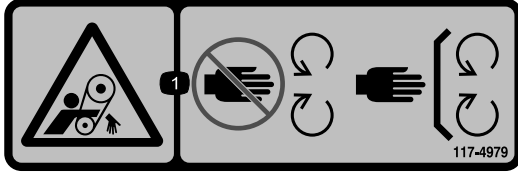

117-4979

1. Entanglement hazard, belt—stay away from moving parts, keep all guards and shields in place.

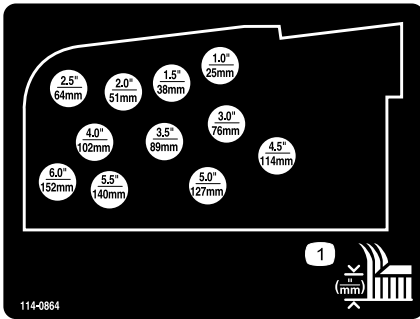

114-0864

1. Height of cut adjustment

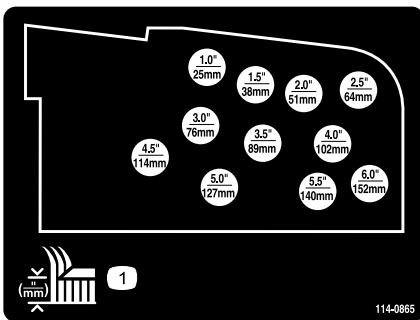

114-0865

1. Height of cut adjustment

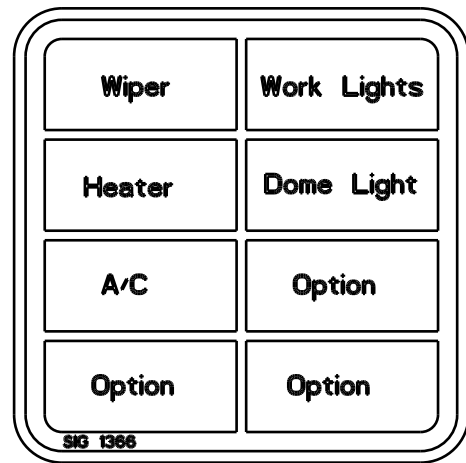

115-5509

(Model 31599 only)



115-5489

(Model 31599 only)

1. Warning—when the cab windows are open wear hearing protection.
2. Close the rear window before attempting to open the hood.



**Battery Symbols**

Some or all of these symbols are on your battery

- |  |  |
|--|--|
| 1. Explosion hazard                    | 6. Keep bystanders a safe distance from the battery.                           |
| 2. No fire, open flame, or smoking.    | 7. Wear eye protection; explosive gases can cause blindness and other injuries |
| 3. Caustic liquid/chemical burn hazard | 8. Battery acid can cause blindness or severe burns.                           |
| 4. Wear eye protection                 | 9. Flush eyes immediately with water and get medical help fast.                |
| 5. Read the <i>Operator's Manual</i> . | 10. Contains lead; do not discard.   |

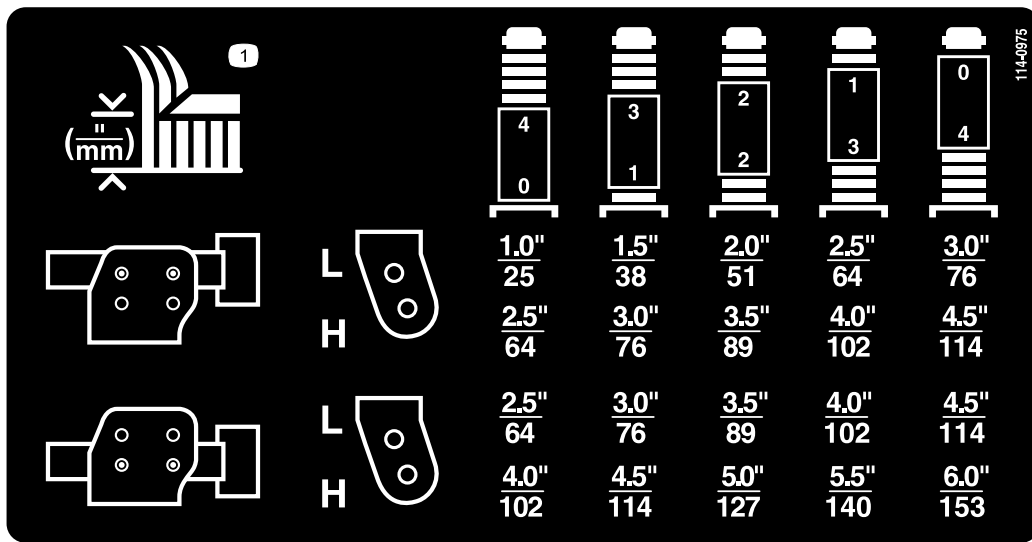

114-0975

1. Height-of-cut

### GROUNDMASTER 5900 QUICK REFERENCE AID

**CHECK/SERVICE (DAILY)**

- ENGINE OIL LEVEL
- HYDRAULIC FLUID LEVEL
- ENGINE COOLANT LEVEL
- FUEL - DIESEL ONLY
- FUEL/WATER SEPARATOR
- ALTERNATOR BELT TENSION
- RADIATOR SCREEN
- AIR CLEANER
- BRAKE FUNCTION
- INTERLOCK SYSTEM
- TIRE PRESSURE -  
FRONT = 50 PSI/3.40 BAR  
REAR = 30 PSI/2.10 BAR
- GREASE POINTS (10)  
SEE OPERATOR'S MANUAL FOR  
50 HR INTERVAL GREASE POINTS.
- A/C COMPRESSOR BELT TENSION

**SPECIFICATIONS/CHANGE INTERVALS**

SEE OPERATOR'S MANUAL FOR INITIAL CHANGES.	FLUID TYPE	CAPACITY	CHANGE INTERVAL		FILTER PART NO.
			FLUID	FILTER	
ENGINE OIL	15W-40 CH-4	8.5 QUARTS	250 HOURS	250 HOURS	115-8868 (A)
HYDRAULIC FLUID	ISO VG 46	76 QUARTS	1000 HOURS	1000 HOURS	75-1310 (B) 86-6110 (C)
PRIMARY AIR FILTER					SEE SERVICE INSTRUCTIONS 115-8887 (D)
SAFETY AIR FILTER					SEE OPERATOR'S MANUAL 115-8877 (E)
FUEL SYSTEM	> 32 F	NO. 2 DIESEL B20	35 GALLONS	1000 HOURS DRAIN/FLUSH	500 HOURS
	< 32 F	NO. 1 D / NO. 2 D DIESEL BLEND			
PLANETARY DRIVE - WET BRAKE	85W-140	22 OUNCES	800 HOURS		
ENGINE COOLANT	50% WATER 50% ETHYL GLYCOL	13.5 QUARTS 18.0 QTS W/ CAB	DRAIN&FLUSH EVERY 2 YRS.		

125-5318

1. Read the *Operator's Manual* for information on maintenance.

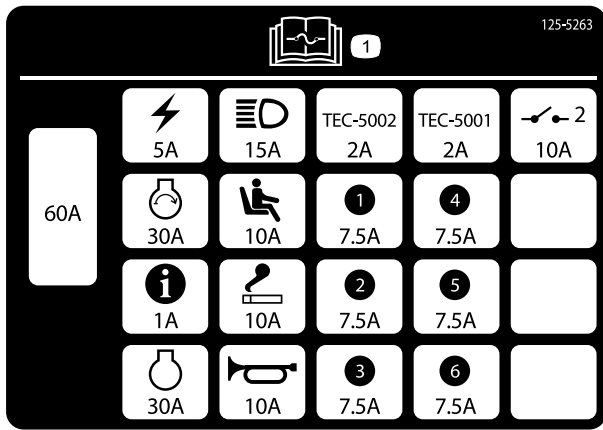

**125-5263**

1. Read the *Operator's Manual* for information on fuses.

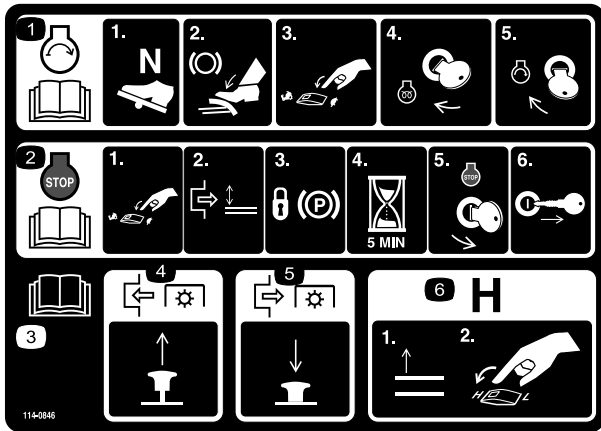

**114-0846**

1. Read the *Operators Manual*; to start the engine, move the traction pedal to Neutral, apply the brake, move the throttle switch to low, turn the ignition key to Preheat. When the Wait to Start Advisory clears on the Info Center then turn the ignition key to Start.
2. Read the *Operators Manual*; to stop the engine, move the throttle lever to slow, disengage the PTO, set the parking brake, wait 5 minutes, turn the ignition key to Stop, and remove the key; read the *Operators Manual*.
3. Read the *Operators Manual*.
4. To engage the PTO, pull up on the PTO switch.
5. To disengage the PTO, push down on the PTO switch.
6. To switch the transmission to high speed, fully raise the attachments and switch the speed control to High.

# Setup

## Loose Parts

Use the chart below to verify that all parts have been shipped.

Procedure	Description	Qty.	Use
<b>1</b>	No parts required	–	Remove the side deck straps and brace
<b>2</b>	Deck cover R.H. Deck cover L.H. V-Belt	1 1 2	Lower the front deck winglets
<b>3</b>	No parts required	–	Level the front center deck
<b>4</b>	No parts required	–	Level winglet decks to front center deck
<b>5</b>	No parts required	–	Check the Tire Pressure
<b>6</b>	No parts required	–	Check Fluid Levels
<b>7</b>	No parts required	–	Grease the machine.

## Media and Additional Parts

Description	Qty.	Use
Operator's Manual	1	Provide the operator with information on the use and maintenance of the machine
Engine Operator's Manual	1	
Operator Training Material	1	
Parts Catalog	1	Ordering parts
Declaration of Conformity	1	

**Note:** Determine the left and right sides of the machine from the normal operating position.

**Note:** Some parts may have already been installed at the factory.

# 1

## Remove Side Deck Shipping Strap and Brace

### No Parts Required

### Procedure

Remove the strap and brace securing the side decks for shipping.

# 2

## Lower Front Deck Winglets

### Parts needed for this procedure:

1	Deck cover R.H.
1	Deck cover L.H.
2	V-Belt

### Procedure

1. Remove the nuts securing the front and rear stop bolts to the right winglet deck mounts ([Figure 3](#)).
2. While supporting the right winglet, remove the front and rear stop bolts from the deck mounts ([Figure](#)

3). Leave the eccentrics positioned between the deck mounts.

3. Lower the winglet to the operating position.

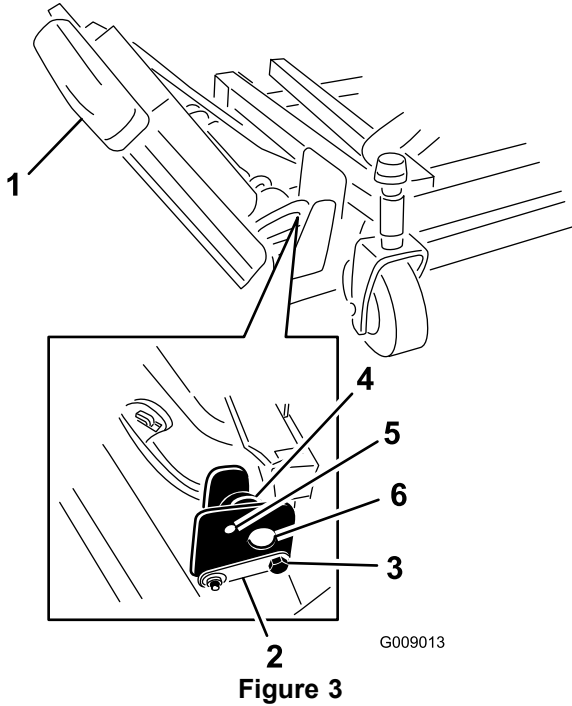

**Figure 3**

- |              |                |
|--------------|----------------|
| 1. Winglet   | 4. Eccentric   |
| 2. Hinge pin | 5. Upper hole  |
| 3. Stop bolt | 6. Deck mounts |

4. Install the front and rear stop bolts through the upper mounting holes and eccentrics. Make sure the stop bolt engages the tab on the hinge pin.
5. Install the nuts securing the stop bolts but do not tighten at this time.
6. Repeat the procedure on left winglet.

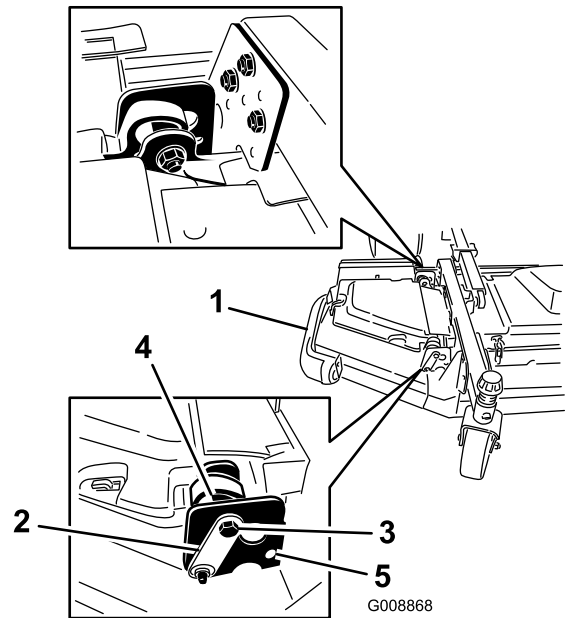
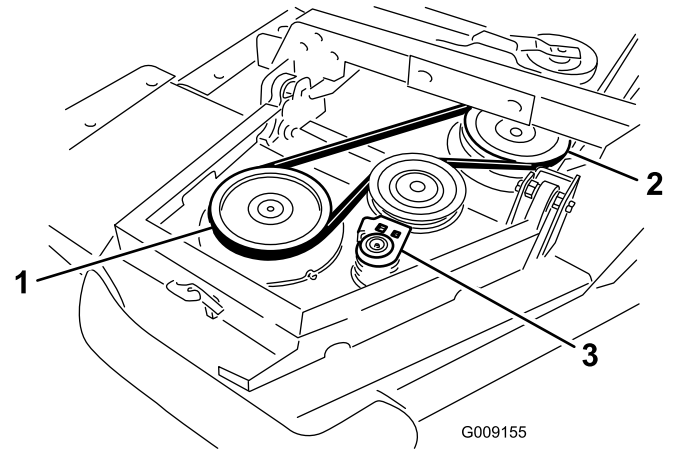

**Figure 4**

- |              |               |
|--------------|---------------|
| 1. Winglet   | 4. Eccentric  |
| 2. Hinge pin | 5. Lower hole |
| 3. Bolt      |               |

7. Install the winglet belts as follows:

- Start the belt around the winglet spindle pulley and the front deck spindle pulley (Figure 5).
- Using a ratchet wrench or similar tool, move the idler pulley away from the pulleys (Figure 5).
- Route the belt around the winglet spindle pulley and the upper spindle pulley on the front deck.
- Release the idler pulley to put tension on the belt.



**Figure 5**

- |                              |                          |
|------------------------------|--------------------------|
| 1. Winglet spindle pulley    | 3. Idler pulley assembly |
| 2. Front deck spindle pulley |                          |

8. Install the winglet deck cover and secure with rubber latch (Figure 6).

**Note:** Make sure to slide the cover under the front center deck cover tabs before inserting it onto the mounting hooks and post.

- Repeat the procedure on the other winglet.

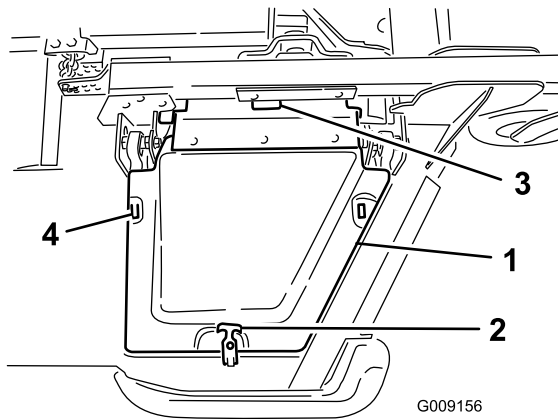

**Figure 6**

- |                 |                                 |
|-----------------|---------------------------------|
| 1. Cover        | 3. Front center deck cover tabs |
| 2. Rubber latch | 4. Mount hooks                  |

# 4

## Level Winglet Decks to Front Center Deck

### No Parts Required

### Procedure

Level the winglet decks to the front deck as follows:

- Rotate the blade on each winglet so that it points side to side.
- Loosen the bolts and nuts securing the two eccentric spacers to the winglets (Figure 7).

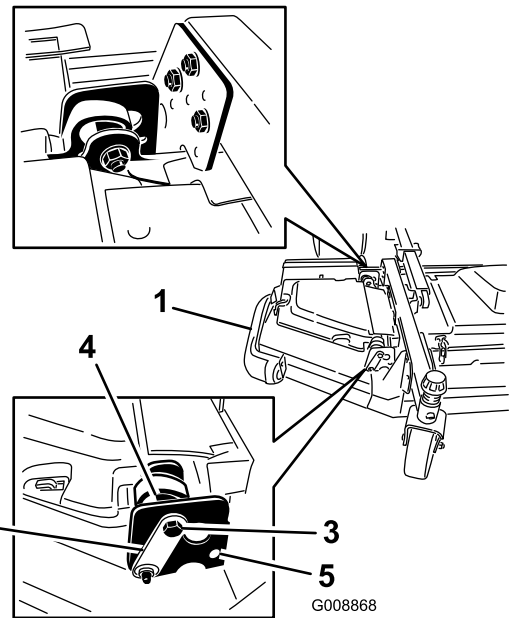

**Figure 7**

- |              |               |
|--------------|---------------|
| 1. Winglet   | 4. Eccentric  |
| 2. Hinge pin | 5. Upper hole |
| 3. Stop bolt |               |

- Rotate the rear (closest to traction unit) eccentric until the outside blade tip is about 1/8 inch higher than the desired height of cut (Figure 7).

**Note:** There is a notch on the eccentric hex which is 180° from the lobe on the eccentric cam (Figure 8). Use the notches to reference the location of the lobes when adjusting the eccentrics.

# 3

## Level Front Center Deck

### No Parts Required

### Procedure

Refer to Adjusting the Height-of-Cut in Operation.

- Rotate blade on each outer spindle until the ends face forward and backward.
- Measure from the floor to the front tip of the blade. Adjust 1/8 inch shims on front castor fork(s) to match desired height of cut.
- Rotate the blades 180° and now measure from the floor to the (rear facing) tip of the blade.
- Loosen the lower jam nuts on the height-of-cut chain U-bolt.
- Adjust the nuts to raise or lower the rear of the cutting unit so that the front and rear blade tips have the same measurement. Tighten the jam nuts.
- Proceed to procedure 4 and level the winglet decks to the front center deck.

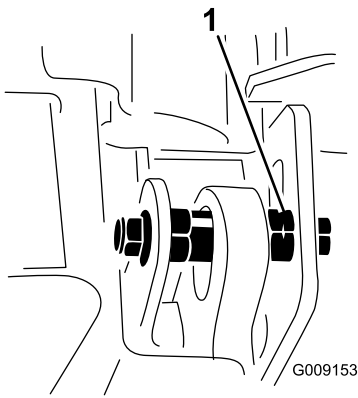

**Figure 8**

1. Eccentric notch

- Tighten the bolt and nut for this eccentric to 110 ft-lb (149 N-m).
- Adjust the forward eccentric until it just makes contact with the inner slot surface of the winglet pivot brackets.
- Tighten the bolt and nut for this eccentric to 110 ft-lb (149 N-m).
- Repeat the procedure on the opposite winglet. Refer to Adjusting the Cutting Unit Pitch procedure in Mower Maintenance.

## 5

### Checking Tire Pressure

#### No Parts Required

#### Procedure

Check the air pressure in all the tires before operating the machine. The correct air pressure in the front tires is 50 psi (345 kPa) and the rear tires is 30 psi (207 kPa) (Figure 9).

**Important:** Maintain pressure in all tires to ensure a good quality-of-cut and proper machine performance. *Do not under-inflate.*

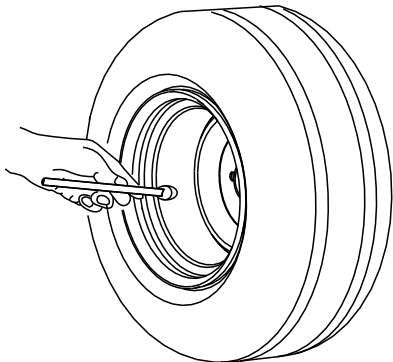

**Figure 9**

## 6

### Checking Fluid Levels

#### No Parts Required

#### Procedure

1. Check the engine oil level before starting the engine, refer to Checking the Engine Oil Level in Engine Maintenance.
2. Check the hydraulic fluid level before starting the engine, refer to Checking the Hydraulic Fluid Level in Hydraulic System Maintenance.
3. Check the cooling system before starting the engine; refer to Checking the Cooling System in Cooling System Maintenance.

## 7

### Greasing Machine

#### No Parts Required

#### Procedure

Before the machine is operated, it must be greased to ensure proper lubricating characteristics; refer to Greasing the Bearings and Bushings procedure in Lubrication in the Maintenance Section. Failure to properly grease the machine will result in premature failure of critical parts.

# Product Overview

## Controls

**Note:** Determine the left and right sides of the machine from the normal operating position.

### ⚠ CAUTION

This machine produces sound levels in excess of 85 dBA at the operators ear and can cause hearing loss through extended periods of exposure.

Wear hearing protection when operating this machine.

## Traction Pedal

The traction pedal (Figure 10) controls forward and reverse operation. Press the top of the pedal to move forward and the bottom to move backward. Ground speed depends on how far you press the pedal. For no load, maximum ground speed, fully press the pedal while the throttle is in the Hi idle position.

To stop, reduce your foot pressure on the traction pedal and allow it to return to the center position.

## Brake Pedals

Two foot pedals (Figure 10) operate individual wheel brakes for turning assistance, parking, and to aid in obtaining better side hill traction. A latch connects the pedals for parking brake operation and transport.

## Pedal Locking Latch

The pedal locking latch (Figure 10) connects the pedals together to engage the parking brake.

## Tilt Steering Lever

Press the lever (Figure 10) down to tilt the steering wheel to the desired position. Then release the lever to lock the adjustment.

## Turn Signal Switch

Press the left side of the turn signal switch (Figure 10) to activate the left turn signal and the right side of the switch to activate the right turn signal. The center position is off.

## Hi-Lo Speed Switch

Press the front of the switch (Figure 10) to select high speed range. Press the rear of the switch to select low speed range. The machine must be stationary or traveling at a very slow speed, less than 2 mph, to shift to Hi or Lo.

## Horn Button

Press the horn button (Figure 10) to activate the horn.

## Parking Brake Latch

The knob on the left side of the console actuates the parking brake lock (Figure 10). To engage the parking brake, connect the pedals with the locking latch, push down on both pedals, and pull the parking brake latch out. To release the parking brake, press both pedals until the parking brake latch retracts.

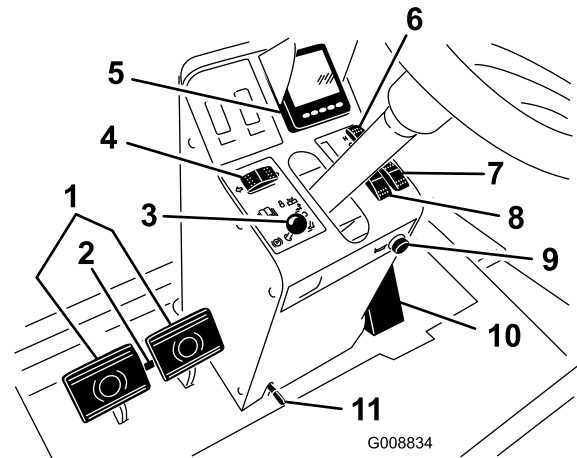

Figure 10

- |                        |                             |
|------------------------|-----------------------------|
| 1. Brake pedals        | 7. Variable throttle switch |
| 2. Pedal locking latch | 8. Throttle switch          |
| 3. Parking brake latch | 9. Horn                     |
| 4. Turn signal switch  | 10. Traction pedal          |
| 5. Info center         | 11. Tilt steering lever     |
| 6. Hi-lo speed control |                             |

## Throttle Switch

The throttle switch (Figure 11) has three positions low idle, mid idle and high idle.

## Variable Throttle Switch

The variable throttle switch (Figure 11) allows the engine speed to be adjusted in small increments. Press the “+” once to increase the engine speed and the “-” once to decrease the engine speed.

**Note:** Moving the throttle switch will override and cancel the variable throttle setting.

**Important:** Do not operate the engine below 1350 rpm.

## Lift Switches

The lift switches (Figure 11) raise and lower the cutting units. Press the switches forward to lower the cutting unit and backward to raise the cutting units.

**Note:** The decks will not lower while in the Hi speed range, and the decks will not raise or lower if the operator is out of the seat when the engine is running.

## Key Switch

The key switch (Figure 11) has three positions: Stop, Run/Preheat, and Start.

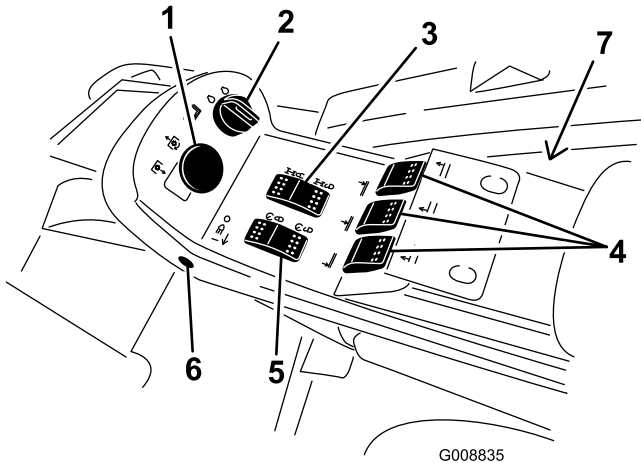

Figure 11

- |                           |   |
|---------------------------|---|
| 1. PTO switch             | 5. Cruise control                             |
| 2. Key switch             | 6. Light switch                               |
| 3. Traction assist switch | 7. Power point (on the right side of console) |
| 4. Lift switches          |   |

## PTO Switch

The PTO switch (Figure 11) has two positions: Out (start) and In (stop). Pull the PTO button out to engage the implement or cutting unit blades. Push in the button to disengage the implement operation.

## Traction Assist Switch

When operating in mow (low) speed, press and hold the traction assist switch (Figure 11) to enhance traction drive performance in compromised operating conditions.

**Note:** The traction assist only engages in Mow- Forward. The traction assist will not engage in Mow-Reverse or Hi speed range.

## Cruise Control Switch

The cruise control switch (Figure 11) sets the speed of the machine. Pressing the rear of the switch turns off the cruise control, the middle position of the switch enables the cruise control function and the front of the switch sets the desired ground speed.

**Note:** Pressing either brake pedal or moving the traction pedal into the reverse position, for one second, will also disengage the cruise control.

## Light Switch

Press the lower edge of the switch (Figure 11) to turn on the lights. Press the upper edge of the switch to turn off the lights.

## Audible Alarm (Console)

The alarm is activated when a fault is detected.

The buzzer sounds:

- continuous when the engine sends a stop fault.
- with a short pulse when the engine sends a check engine fault.
- when there is low fuel.

## Power Point

The power point, located next to the console on the side of the power center, is used to power optional electrical accessories (Figure 11).

## Seat Adjustments

### Weight gauge

Indicates when the seat is adjusted to the weight of the operator (Figure 12). Height adjustment is made by positioning the suspension within the range of the green region.

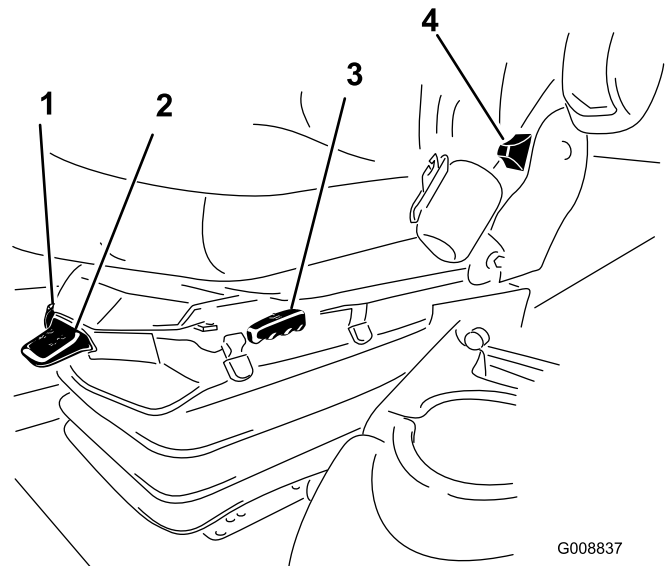

Figure 12

- |                                 |                              |
|---------------------------------|------------------------------|
| 1. Weight gauge                 | 4. Seat back adjusting lever |
| 2. Weight adjusting lever       | 5. Arm rest adjusting knob   |
| 3. Fore and Aft adjusting lever |                              |

### Weight Adjusting Lever

Adjust for operator weight (Figure 12). Pull up on the lever to increase the air pressure and push down to decrease the air

pressure. The proper adjustment is attained when the weight gauge is in the green region.

## Fore and Aft Adjusting Lever

Pull out on the lever to slide the seat fore or aft (Figure 12).

## Seat Back Adjusting Lever

Move the lever to adjust the seat back angle (Figure 12).

## Seat Arm Rest Adjusting Knob

Rotate the knob to adjust the seat arm rest angle (Figure 12).

## Cab Controls

Model 31599 only

### Wind Shield Wiper Switch

Press front of switch to activate the wind shield wipers (Figure 13) and rear of switch to turn off the wipers.

### Air Conditioning Switch

Press front of switch to activate the air conditioning (Figure 13) and rear of switch to turn off the air conditioning.

### Fan Control

Rotate the fan control knob to regulate the speed of the fan (Figure 13).

### Temperature Control

Rotate the temperature control knob to regulate the air temperature in the cab (Figure 13).

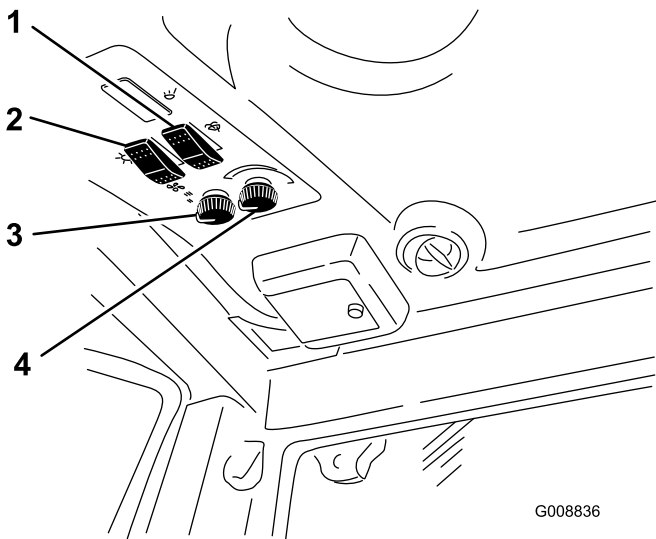

Figure 13

- |                             |                        |
|-----------------------------|------------------------|
| 1. Wind shield wiper switch | 3. Fan control         |
| 2. Air conditioning switch  | 4. Temperature control |

## Wind Shield Latch

Lift up on latches to open the wind shield (Figure 14). Press in on latch to lock wind shield in open position. Pull out and down on latch to close and secure wind shield.

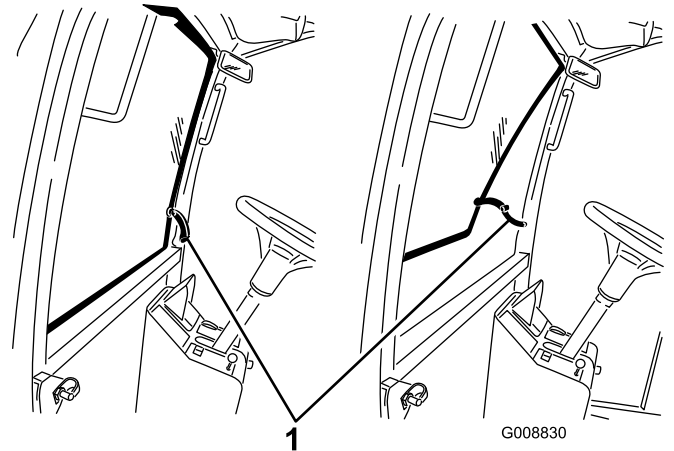

Figure 14

1. Wind shield latch

## Rear Window Latch

Lift up on latches to open the rear window. Press in on latch to lock window in open position. Pull out and down on latch to close and secure window (Figure 14).

**Important:** The rear window must be closed before opening the hood or damage may occur.

## Info Center

### Screen Functions

- Press the corresponding button to view screen 1 or screen 2, to stop audible alarm, to view fault screen or to exit (Figure 15).
- If a fault appears on the screen, press any key to view the active fault advisory. Contact your supervisor or mechanic to relay fault advisory and determine course of action.
- Press the arrow keys to navigate the fault screen.
- Press any key to reveal the information keys on the screen.

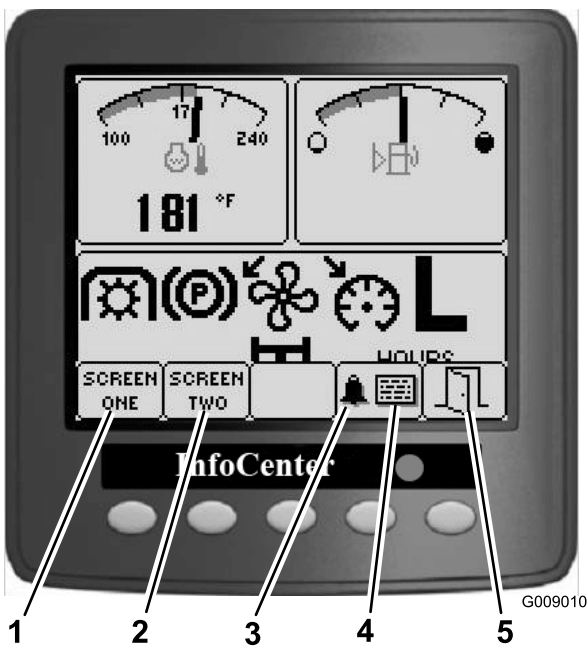

Figure 15

- |                  |                 |
|------------------|-----------------|
| 1. Screen 1      | 4. Fault screen |
| 2. Screen 2      | 5. Exit         |
| 3. Audible alarm |                 |

### Operator Information

There are two screens that will monitor and display the machine functions that the operator can use.

#### Screen 1 will display:

Top Left Gauge-Engine Coolant Temperature

Top Right Gauge-Fuel Level

Left to Right on the Bottom Half

1. PTO Engaged
2. Parking Brake Engaged
3. Fan Reversing
4. Cruise Control Engaged
5. H/L (Hi/Low speed range)

Bottom Left Corner-Air Intake Heater Active

Bottom Middle-Traction Assist Engaged

Bottom Right-Machine Hours

#### Screen 2 will display:

Top Left Corner-Engine RPM

Top Right Corner-Hydraulic Oil Temperature

Lower Left Corner-Battery Voltage

Lower Right Corner-Service Due

### Engine Coolant Temperature Indicator

This display indicates the engine coolant temperature (Figure 16).

### Parking Brake Indicator

This display indicates that the parking brake is actuated (Figure 16).

### PTO Indicator

This display indicates (Figure 16) when the PTO is engaged.

### Fan Reverse Indicator

This display indicates (Figure 16) when the fan is operating in reverse. The fan speed will be controlled by the hydraulic oil temperature, air intake temperature or engine coolant temperature and will automatically reverse. A reverse cycle is automatically initiated, to help blow debris off of the rear hood screen, when either the engine coolant temperature or hydraulic oil temperature reaches a certain point.

### Cruise Control Indicator

This display indicates (Figure 16) when the cruise control is in operation.

### Fuel Level Indicator

This display indicates the level of fuel in the tank (Figure 16).

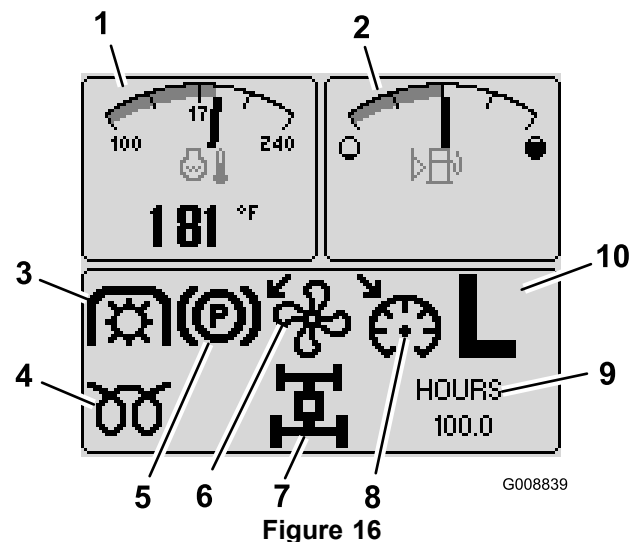

Figure 16

- |   |                                |
|---|--------------------------------|
| 1. Engine coolant temperature indicator | 6. Fan reverse indicator       |
| 2. Fuel indicator                       | 7. Traction assist indicator   |
| 3. PTO indicator                        | 8. Cruise control indicator    |
| 4. Air intake heater indicator          | 9. Machine hours indicator     |
| 5. Parking brake indicator              | 10. H / L (Hi / Low) indicator |

## H / L (Hi/Low Range) Indicator

This display indicates which speed range has been selected (Figure 16).

## Air Intake Heater Indicator

This display indicates when the system is pre heating (Figure 16).

## Traction Assist Indicator

This display indicates when the traction assist is engaged (Figure 16).

## Machine Hours Indicator

This display shows the total hours that the machine has been operated (Figure 17).

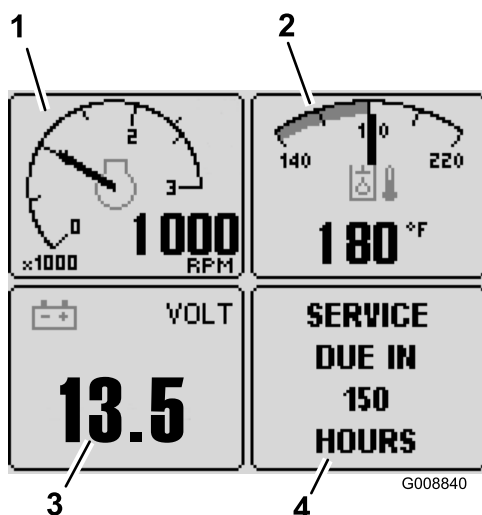

Figure 17

- |                              |                    |
|------------------------------|--------------------|
| 1. Tachometer                | 3. Battery voltage |
| 2. Hydraulic oil temperature | 4. Service due     |

## Tachometer

This display shows the engine operating speed in RPM (Figure 17).

## Battery Voltage

This display shows the battery voltage (Figure 17).

## Hydraulic Oil Temperature Indicator

This display indicates the hydraulic oil temperature (Figure 17).

## Service Due Indicator

This display indicates the time until the next regular service interval (Figure 17).

**Note:** When service has been performed, make sure to reset the indicator.

## Resetting the Service Interval Indicator

1. Press and hold the far right button on the Info Center.
2. The Main Menu screen will come up. Select SERVICE using the 2 buttons on the left; press the button below the right arrow to continue.
3. Select HOURS and press the button below the right arrow.
4. Press the button below RESET HOURS.
5. Select the HOURS for the appropriate next service time and press the button below the right arrow. A check mark will appear once it has been reset. When finished, press the button below the exit icon (picture of a door open) to return to the main screen, or press cancel to exit.

## Engine Air Filter Restriction Indicator

This display (Figure 18) indicates when the engine air filter is restricted.



Figure 18

## Alarm (InfoCenter)

The InfoCenter's alarm sounds when:

- an engine fault is received
- an advisory or fault is received from the TEC controllers
- starting the machine

## Info Center

### Fault Indicators

**Stop** -If the driver receives a STOP indication, the driver should cease operation of the machine and the engine as quickly and as safely as possible to reduce damage to the engine (Figure 19).

**Check Engine** -If the driver receives a Check Engine indication for a maintenance fault, the driver should take the machine to a service center as soon as possible.



**Figure 19**  
Fault Example

1. Fault screen

## Advisories

Advisories provide the operator additional information to operate certain functions on the machine (Figure 20).



**Figure 20**  
Advisory Example

1. Advisory screen

## To Set Cruise Control

Increase ground speed

## To Float Deck

Lower decks

## To Lower Deck

1. Operator must be seated
2. Select low range
3. Set parking brake

## Electronics Issues

1. Fix High/Low range switch
2. Controller firmware incompatible
3. Blown fuse
4. HHDT ready

## Engine

1. Lower engine speed
2. Wait to shutoff engine

## Fuel Level

Add fuel

## To Engage PTO

1. Solve engine fault
2. Let engine warm up
3. Let hydraulic oil warm
4. Lower decks
5. Must be in low range
6. Operator must be seated

## To Set High Range

1. Disengage cruise
2. Disengage PTO
3. Lift left deck
4. Lift center deck
5. Lift right deck
6. Reduce ground speed

## To Set Low Range

1. Disengage cruise
2. Reduce ground speed

## To Start

1. Disengage deck switch
2. Disengage PTO
3. Move traction pedal to neutral
4. Insert jumper in teach plug

5. Engine running
6. Must be seated or set parking brake
7. Turn key switch off then on
8. Wait

5. Release parking brake
6. Operator must be seated

#### For Teach (Traction Pedal Calibration)

Turn key switch off then on

#### For Traction

1. Fix critical sensor error
2. Fix critical voltage error
3. Move forward
4. Move traction pedal to neutral

#### For Traction Assist

1. Must be in low range
2. Operator must be seated

#### Traction Derate Due To

1. Requires service
2. Engine or hydraulics too hot
3. Traction pedal sensor needs calibration
4. Reserved 1
5. Reserved 2
6. Reserved 3

## Specifications

**Note:** Specifications and design are subject to change without notice.

Width of cut	
overall	192 inches (488 cm)
front cutting unit	92 inches (234 cm)
side cutting unit	57 inches (145 cm)
front and one side cutting unit	142 inches (361 cm)
Overall width	
cutting units down	199 inches (505 cm)
cutting units up (transports)	99 inches (251 cm)
Overall height	
with ROPS	89 inches (226 cm)
without ROPS	60 inches (152 cm)
with cab	93 inches (236 cm)
Overall length	175 inches (445 cm)
Minimum ground clearance (at machine centerline)	9.5 inches (24 cm)
Wheel tread (to center of tire)	
front	63 inches (160 cm)
rear	56 inches (142 cm)
Wheel tread (to outside of tire)	
front	76 inches (193 cm)
rear	66 inches (168 cm)
Wheel base	76 inches (193 cm)
Net Weight (with cutting units)	
without cab	5,966 lb (2706 kg)
with cab	6,457 lb (2929 kg)

## Attachments/Accessories

A selection of Toro approved attachments and accessories is available for use with the machine to enhance and expand

its capabilities. Contact your Authorized Service Dealer or Distributor or go to [www.Toro.com](http://www.Toro.com) for a list of all approved attachments and accessories.

# Operation

**Note:** Determine the left and right sides of the machine from the normal operating position.

## ⚠ CAUTION

This machine produces sound levels in excess of 85 dBA at the operators ear and can cause hearing loss through extended periods of exposure.

Wear hearing protection when operating this machine.

## Checking the Engine Oil Level

Before you start the engine and use the machine, check the oil level in the engine crankcase; refer to Checking Oil Level in Engine Maintenance.

## Checking the Cooling System

Before you start the engine and use the machine, check the cooling system; refer to Checking the Cooling System in Cooling System Maintenance.

## Checking the Hydraulic System

Before you start the engine and use the machine, check the hydraulic system; refer to Checking the Hydraulic System in Hydraulic System Maintenance.

## Adding Fuel

Use only clean, fresh diesel fuel or biodiesel fuels with low (<500 ppm) or ultra low (<15 ppm) sulfur content. The minimum cetane rating should be 40. Purchase fuel in quantities that can be used within 180 days to ensure fuel freshness.

**Fuel tank capacity:** 35 US gallons (132 liters)

Use summer grade diesel fuel (No. 2-D) at temperatures above 20° F (-7° C) and winter grade (No. 1-D or No. 1-D/2-D blend) below that temperature. Use of winter grade fuel at lower temperatures provides lower flash point and cold flow characteristics which will ease starting and reduce fuel filter plugging.

Use of summer grade fuel above 20° F (-7° C) will contribute toward longer fuel pump life and increased power compared to winter grade fuel.

**Important:** Do not use kerosene or gasoline instead of diesel fuel. Failure to observe this caution will damage the engine.

## ⚠ WARNING

Fuel is harmful or fatal if swallowed. Long-term exposure to vapors can cause serious injury and illness.

- Avoid prolonged breathing of vapors.
- Keep face away from nozzle and fuel tank or conditioner opening.
- Keep fuel away from eyes and skin.

### Biodiesel Ready

This machine can also use a biodiesel blended fuel of up to B20 (20% biodiesel, 80% petrodiesel). The petrodiesel portion should be low or ultra low sulfur. Observe the following precautions:

- The biodiesel portion of the fuel must meet specification ASTM D6751 or EN14214.
- The blended fuel composition should meet ASTM D975 or EN590.
- Painted surfaces may be damaged by biodiesel blends.
- Use B5 (biodiesel content of 5%) or lesser blends in cold weather.
- Monitor seals, hoses, gaskets in contact with fuel as they may be degraded over time.
- Fuel filter plugging may be expected for a time after converting to biodiesel blended.
- Contact your distributor if you wish more information on biodiesel.

In certain conditions during fueling, static electricity can be released causing a spark which can ignite the fuel vapors. A fire or explosion from fuel can burn you and others and can damage property.

- Always place fuel containers on the ground away from your vehicle before filling.
- Do not fill fuel containers inside a vehicle or on a truck or trailer bed because interior carpets or plastic truck bed liners may insulate the container and slow the loss of any static charge.
- When practical, remove equipment from the truck or trailer and refuel the equipment with its wheels on the ground.
- If this is not possible, then refuel such equipment on a truck or trailer from a portable container, rather than from a fuel dispenser nozzle.
- If a fuel dispenser nozzle must be used, keep the nozzle in contact with the rim of the fuel tank or container opening at all times until fueling is complete.

## ⚠ DANGER

In certain conditions, fuel is extremely flammable and highly explosive. A fire or explosion from fuel can burn you and others and can damage property.

- Fill the fuel tank outdoors, in an open area, when the engine is cold. Wipe up any fuel that spills.
- Never fill the fuel tank inside an enclosed trailer.
- Never smoke when handling fuel, and stay away from an open flame or where fuel fumes may be ignited by a spark.
- Store fuel in an approved container and keep it out of the reach of children. Never buy more than a 180-day supply of fuel.
- Do not operate machine without entire exhaust system in place and in proper working condition.

## Filling the Fuel Tank

1. Park the machine on a level surface.
2. Using a clean rag, clean area around fuel tank cap.
3. Remove cap from the fuel tank (Figure 21).

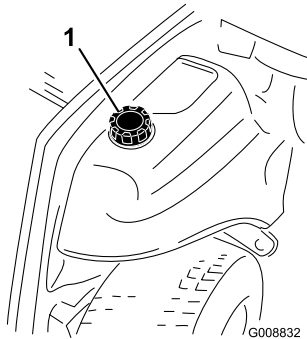

Figure 21

1. Fuel tank cap

4. Fill the tank until the level is to the bottom of the filler neck with diesel fuel.
5. Install fuel tank cap tightly after filling tank.

**Note:** If possible, fill the fuel tank after each use. This will minimize possible buildup of condensation inside the fuel tank.

## Checking the Tire Pressure

**Service Interval:** Before each use or daily

The correct air pressure in the front tires is 50 psi (345 kPa) and the rear tires is 30 psi (207 kPa) (Figure 22).

**Important:** Maintain pressure in all tires to ensure a good quality-of-cut and proper machine performance. *Do not under-inflate.*

Check the air pressure in all the tires before operating the machine.

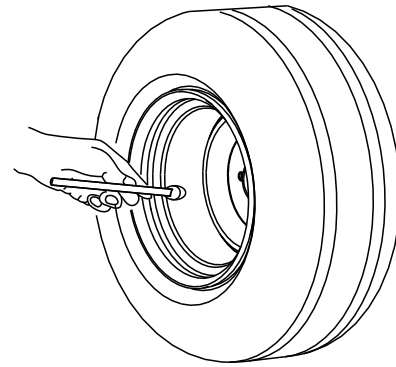

Figure 22

## Checking the Torque of Wheel Lug Nuts

**Service Interval:** After the first 10 hours

Every 250 hours

## ⚠ WARNING

Failure to maintain proper torque of the wheel nuts could result in failure or loss of wheel and may result in personal injury.

Torque the front and rear wheel nuts to 70 to 90 ft-lb (95 to 122 N·m) after 10 hours of operation. Torque every 250 hours thereafter.

## Adjusting the Height-of-Cut

The height-of-cut is adjustable from 1 to 6 inches (25 to 153 mm) in 1/2 inch (13 mm) increments. To adjust the height-of-cut, position the castor wheel axles in the upper or lower holes of the castor forks, add or remove an equal number of spacers from the castor forks, and adjust the rear chain (front deck only) to the desired holes. The higher heights of cut are attained by repositioning the deck caster arms to the lower set of holes on the deck mounting brackets.

## Front Cutting Unit

1. Start the engine and raise the cutting units so that the height-of-cut can be changed. Stop the engine and remove the key after the cutting unit is raised.
2. Position the castor wheel axles in the same holes in all castor forks. Refer to the chart (Figure 23) to determine the correct holes for the setting.

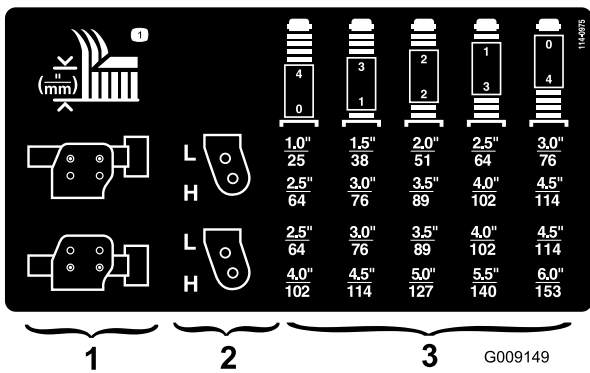

Figure 23

1. Castor arm height of cut mounting holes
2. Castor fork height of cut mounting holes
3. Castor fork height of cut spacers

**Note:** When operating at 2-1/2 inch (64 mm) height of cut or higher, the axle bolt should be installed in the bottom castor fork hole to prevent grass buildup between the wheel and the fork. When operating at heights of cut lower than 2-1/2 inches (64 mm) and grass buildup is detected, reverse the machines direction to pull any clippings away from the wheel/fork area.

3. Remove the tensioning cap from the castor shaft (Figure 24), and slide the shaft out of the castor arm. Put 2 shims (1/8 inch [3 mm]) onto the castor shaft as originally installed. Slide the appropriate number of 1/2 inch spacers onto the shaft to get the desired height-of-cut.

**Note:** The shim washers may be used in any combination above or below the castor arm hub as required to achieve the desired height of cut or deck level.

Refer to the chart (Figure 23) to determine the combinations of spacers for the setting:

4. Push the castor shaft through the front castor arm. Install the shims (as originally installed) and the remaining spacers onto the shaft. Install the tensioning cap to secure the assembly (Figure 24).

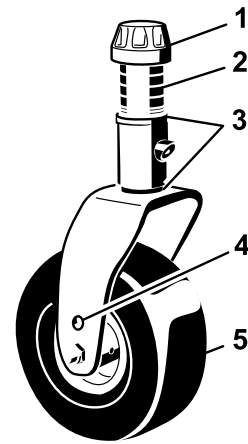

Figure 24

1. Tensioning cap
2. Spacers (4)
3. Shims (2 top & 2 bottom)
4. Top axle mounting hole
5. Castor wheel

5. Remove the hairpin cotter and clevis pin securing the height-of-cut chains to the rear of the cutting unit (Figure 25).

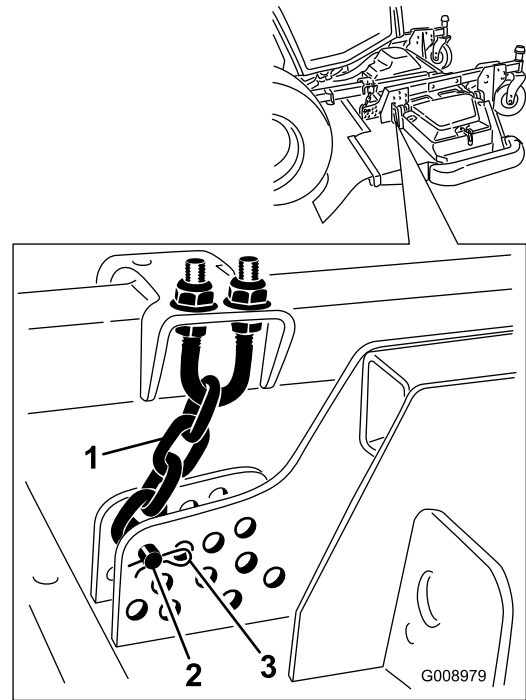

Figure 25

1. Height-of-cut chain
2. Clevis pin
3. Hairpin cotter

6. Mount the height-of-cut chains to the desired height-of-cut hole (Figure 26) with the clevis pin and hairpin cotter.

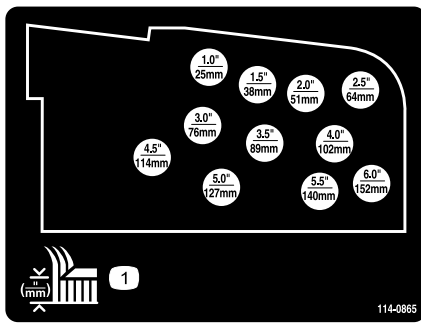

Figure 26

**Note:** When mowing at height-of-cuts below 2-1/2 inches (51 mm), move the skids, gage wheels and rollers to the highest holes.

- To attain the 5 to 6 inch (102 to 153 mm) height of cut settings, remove the mounting bolts securing the deck hanger brackets to the height of cut castor arms and remount the deck hanger brackets to the height of cut castor arms using the lower set of holes (Figure 27).

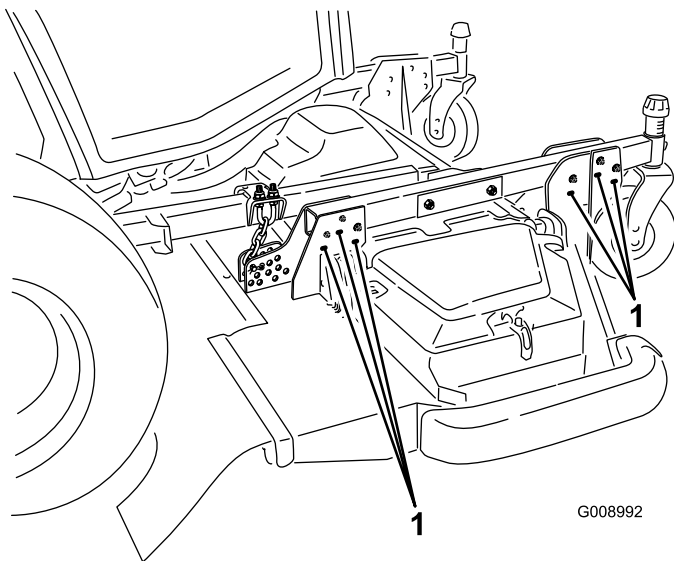

Figure 27

- Lower mounting bolts

Height of Cut	Spacers	Shims
1.0" (25mm)	4	0
1.5" (38mm)	3	1
2.0" (51mm)	2	2
2.5" (64mm)	1	3
3.0" (76mm)	0	4

Figure 28

**Note:** When operating at 2-1/2 inch (64 mm) height of cut or higher, the axle bolt should be installed in the bottom castor fork hole to prevent grass buildup between the wheel and the fork. When operating at heights of cut lower than 2-1/2 inches (64 mm) and grass buildup is detected, reverse the machines direction to pull any clippings away from the wheel/fork area.

- Remove the tensioning cap from the castor spindle shaft (Figure 29) and slide the castor shaft out of the castor arm. Put 2 shims (1/8 inch [3 mm]) onto the shaft as originally installed. Slide the appropriate number of 1/2 inch spacers onto the shaft to get the desired height-of-cut.

**Note:** The shim washers may be used in any combination above or below the castor arm hub as required to achieve the desired height of cut or deck level.

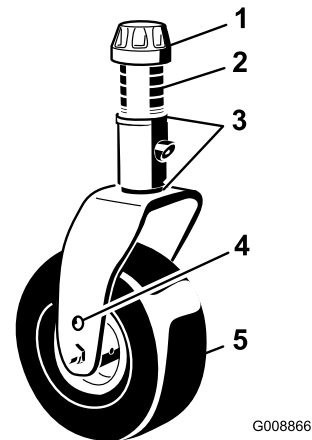

Figure 29

- Tensioning cap
- Spacers (4)
- Shims (2 top and 2 bottom)
- Top axle mounting hole
- Castor wheel

## Side Cutting Units

- Start the engine and raise the cutting units so that the height-of-cut can be changed. Stop the engine and remove the key after the cutting unit is raised.
- Position the castor wheel axles in the same holes in all castor forks. Refer to the chart (Figure 28) to determine the correct holes for the height of cut setting.

- Push the castor shaft through the castor arm. Install the shims (as originally installed) and the remaining spacers onto the shaft. Install the tensioning cap to secure the assembly.

# Adjusting the Skids

The skids should be mounted in the lower position when operating at heights of cut greater than 2-1/2 inches (64 mm) and in the higher position when operating at heights of cut lower than 2-1/2 inches (64 mm).

**Note:** When the skids become worn, you can switch the skid to the opposite sides of the mower, flipping them over. This will allow you to use the skids longer before replacing them.

1. Loosen the screw at the front of each skid (Figure 30).

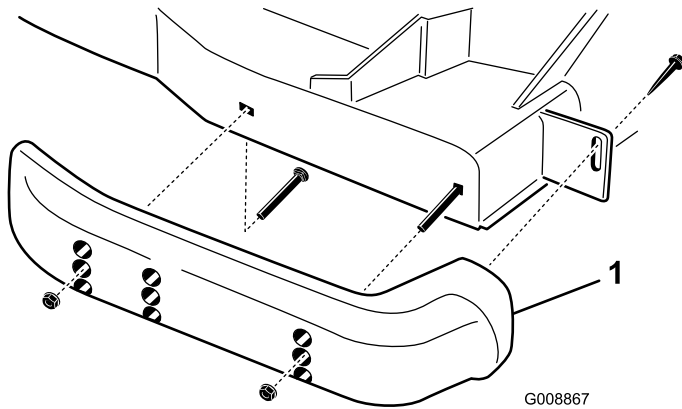

Figure 30

1. Skid

2. Remove the flange-head bolts and nuts from each skid (Figure 30).
3. Move each skid to the desired position and secure them with the flange-head bolts and nuts.

**Note:** Only use the top or center sets of holes to adjust the skids. The bottom holes are used when switching sides at which time they become the top holes on the other side of the mower.

4. Torque the screw at the front of each skid to 80 to 100 in-lb (9 to 11 N·m).

# Adjusting the Cutting Unit Anti-Scalp Rollers

The cutting unit gage wheels and roller should be mounted in the lower position when operating at heights of cut greater than 2-1/2 inches (64 mm) and in the higher position when operating at heights of cut lower than 2-1/2 inches (64 mm).

## Adjusting the Roller

1. Remove the screw and nut securing the roller shaft to the deck bracket (Figure 31).

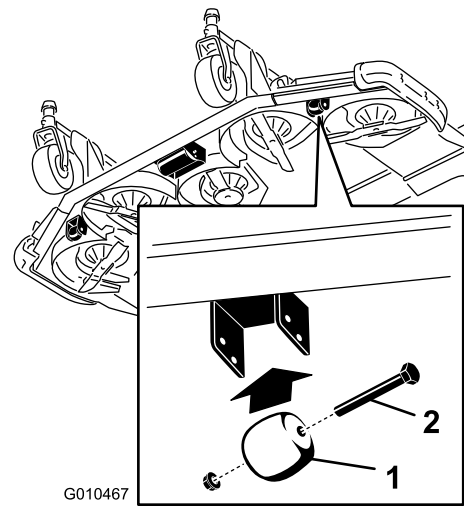

Figure 31

1. Gage wheel
2. Screw and nut

2. Slide the shaft out of the lower bracket holes, align the roller with the top holes, and install the shaft (Figure 32).

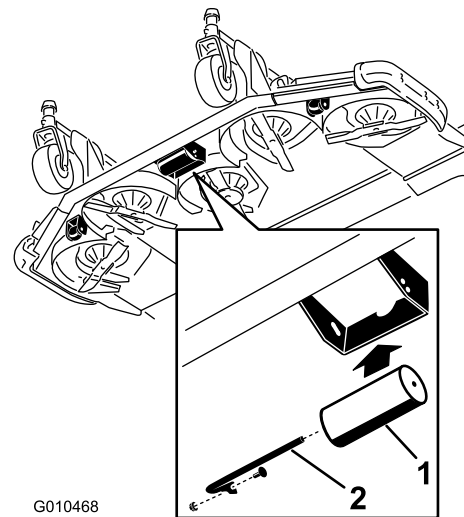

Figure 32

1. Roller
2. Roller shaft, screw and nut

3. Install the screw and nut to secure the assemblies.

## Adjusting the Gage Wheels

1. Remove the bolt and nut securing the gage wheel to the cutting unit brackets (Figure 31).
2. Align the roller and spacer with the top holes in the brackets and secure them with the bolt and nut.

# Checking the Mismatch Between Cutting Units

Due to differences in grass conditions and the counterbalance setting of the traction unit, it is advised that grass be cut and appearance checked before formal cutting is started.

1. Set all cutting units to the desired height of cut; refer to Adjusting the Height of Cut.
2. Check and adjust front and rear tractor tire pressure. The correct air pressure in the front tires is 50 psi (345 kPa) and the rear tires is 30 psi (207 kPa).
3. Check and adjust all castor tire pressures to 50 psi (345 kPa).
4. Check lift and counterbalance pressures with engine at high idle using test ports defined in Hydraulic Systems Test Ports. Adjust as required.
5. Check for bent blades; refer to Checking for a Bent Blade procedure in Mower Maintenance.
6. Cut grass in a test area to determine if all cutting units are cutting at the same height.
7. If cutting unit adjustments are still needed, find a flat surface using a 6 foot (2 m) or longer straight edge to ensure the surface is flat.
8. To ease measuring blade plane, raise the height of cut to the highest position; refer to Adjusting the Height of Cut.
9. Lower cutting units onto the flat surface. Remove the covers from the top of the cutting units.

## Side Cutting Units

1. Rotate blade of each spindle until the ends face forward and backward
2. For the outside blade spindle only, equally adjust the 1/8 inch shims on the front castor forks to match the desired height of cut
3. Measure from floor to the front tip of the cutting blade.
4. Rotate the blade 180° and measure from floor to the tip of the cutting blade.
5. The rear of the blade should be .300 inch (7.5 mm) higher than the front. If adjustment is required, adjust 1/8 inch shims on rear castor forks.

## Matching Height Of Cut Between Cutting Units

1. Position blade side to side on outside spindle of both side cutting units. Measure from the floor to the tip of the cutting edge on both units and compare. These numbers should be within 1/8 inch (3 mm) of each other. Make no adjustment at this time.
2. Position blade side to side on inside spindle of side cutting unit and corresponding outside spindle of front cutting unit. Measure from the floor to the tip of the cutting edge on inside edge of side cutting unit to

corresponding outside edge of front cutting unit and compare.

**Note:** The side cutting unit castor wheels should remain on the ground with counterbalance applied.

**Note:** If adjustments need to be made to match the cut between the front and side cutting units, make the adjustments to the **side cutting units only**.

3. If the inside edge of the side cutting unit is too high relative to the outside edge of the front cutting unit, remove one 1/8 inch shim from the bottom of the front inside castor arm on the side cutting unit (Figure 33 and Figure 34). Recheck measurement between outside edges of both side cutting units and inside edge of side cutting unit to outside edge of front cutting unit.
4. If inside edge is still too high, remove an additional 1/8 inch shim from bottom of front inside castor arm of the side cutting unit **and** one 1/8 inch shim from the front outside castor arm of the side cutting unit (Figure 33 and Figure 34).
5. If the inside edge of the side cutting unit is too low relative to the outside edge of the front cutting unit, add one 1/8 inch shim to the bottom of the front inside castor arm on the side cutting unit (Figure 33 and Figure 34). Check measurement between outside edges of both side cutting units and inside edge of side cutting unit to outside edge of front cutting unit.
6. If inside edge is still too low, add an additional 1/8 inch shim to the bottom of front inside castor arm of the side cutting unit **and** add one 1/8 inch shim to the front outside castor arm of the side cutting unit.
7. Once cutting height matches at the edges of front and side cutting units, verify that side cutting unit pitch is still .300 inch (7.6 mm). Adjust as necessary.

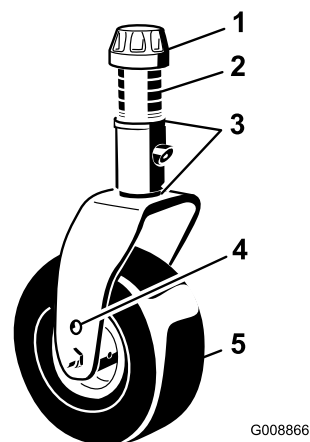

Figure 33

1. Tensioning cap
2. Spacers (4)
3. Shims (2 top and 2 bottom)
4. Top axle mounting hole
5. Castor wheel

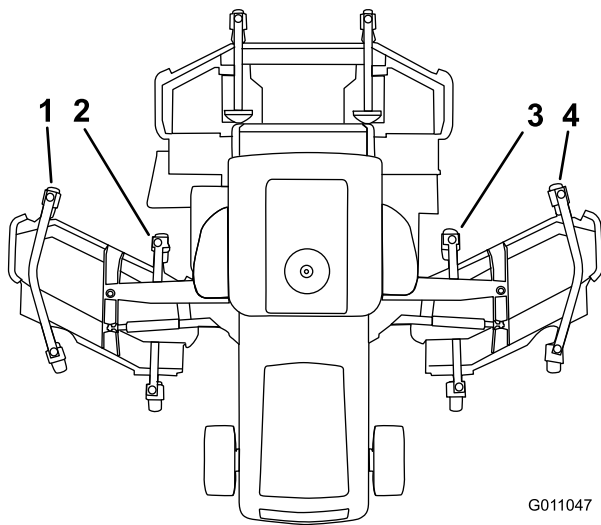

Figure 34

- |                                  |                                   |
|----------------------------------|-----------------------------------|
| 1. Left front outside castor arm | 3. Right front inside castor arm  |
| 2. Left front inside castor arm  | 4. Right front outside castor arm |

## Adjusting the Mirrors

### Rear View Mirror

While sitting in the seat, adjust the rear view mirror (Figure 35) to attain the best view out the rear window. Pull the lever rearward to tilt the mirror to reduce the brightness and glare of light.

### Side View Mirrors

While the sitting in the seat, have a helper adjust the side view mirrors (Figure 35) to attain the best view around the side of the machine.

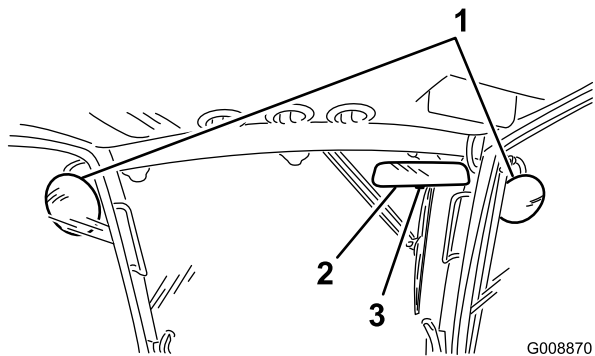

Figure 35

- |                      |          |
|----------------------|----------|
| 1. Side view mirrors | 3. Lever |
| 2. Rear view mirror  |          |

## Aiming the Headlights

1. Loosen the mounting nuts and position each headlight so that it points straight ahead. Tighten the mounting nut just enough to hold the headlight in position.
2. Place a flat piece of sheet metal over the face of the headlight.
3. Mount a magnetic protractor onto the plate. While holding the assembly in place, carefully tilt the headlight downward 3 degrees, then tighten the nut.
4. Repeat the procedure on the other headlight.

## Starting and Stopping the Engine

1. Ensure that the parking brake is set. Remove your foot from the traction pedal and ensure that it is in neutral.
2. Set the throttle switch to the low-idle position.
3. Turn the ignition key to the Run position. The air intake heater icon on the info center will show/disappear.
4. When the glow indicator dims, turn the ignition key to the Start position. Release the key immediately when the engine starts and allow it to return to the Run position. Allow engine to warm up at low speed (without load) for 3 to 5 minutes, then actuate the throttle switches to attain the desired engine speed.

**Important: Do not run the starter motor more than 30 seconds at a time or premature starter failure may result. If the engine fails to start after 30 seconds, turn the key to the Off position, recheck the controls and procedures, wait 2 minutes, and repeat the starting procedure.**

When the temperature is below 20°F (-75°C), let the machine warm up for a minimum of 10 minutes.

5. To stop the engine, set the throttle switch to low idle, move the PTO switch to the Off position, set the parking brake, and rotate the ignition key to Off. Remove the key from the switch to prevent accidental starting.

**Important: Allow engine to idle for 5 minutes before shutting it off after a full load operation. Failure to do so may lead to turbo-charger trouble.**

# Checking the Interlock Switches

## ⚠ CAUTION

If safety interlock switches are disconnected or damaged the machine could operate unexpectedly causing personal injury.

- Do not tamper with the interlock switches.
- Check the operation of the interlock switches daily and replace any damaged switches before operating the machine.

The machine has interlock switches in the electrical system. These switches are designed to stop the engine when operator gets off of the seat when the traction pedal is depressed. However, the operator may get off of the seat while the engine is running, the traction pedal is in neutral and the parking brake engaged.

To check the operation of the interlock switches, perform the following procedure:

1. Drive the machine slowly to a large, relatively open area. Lower the cutting unit, stop the engine, and apply the parking brake.
2. Sit on the seat and depress the traction pedal. Try to start the engine. The engine should not crank. If the engine cranks, there is a malfunction in the interlock system that should be corrected before beginning operation.
3. Sit on the seat and start the engine. Rise from the seat and move the PTO lever to On. The PTO should not engage. If the PTO engages, there is a malfunction in the interlock system that should be corrected before beginning operation.
4. Sit on the seat, engage the parking brake and start the engine. Move the traction pedal out of the neutral position. The traction drive should not function. If the traction drive still functions there is a malfunction in the interlock system that should be corrected before beginning operation.

# Pushing or Towing the Machine

In an emergency, the machine can be moved forward by actuating the bypass valve in the variable displacement hydraulic pump and pushing or towing the machine.

**Important:** Do not push or tow the machine faster than 2-3 MPH (3-4.8 km/h) because internal transmission damage may occur. The bypass valves must be open whenever the machine is pushed or towed.

1. Raise the hood and locate the bypass valves on the pump (Figure 36).

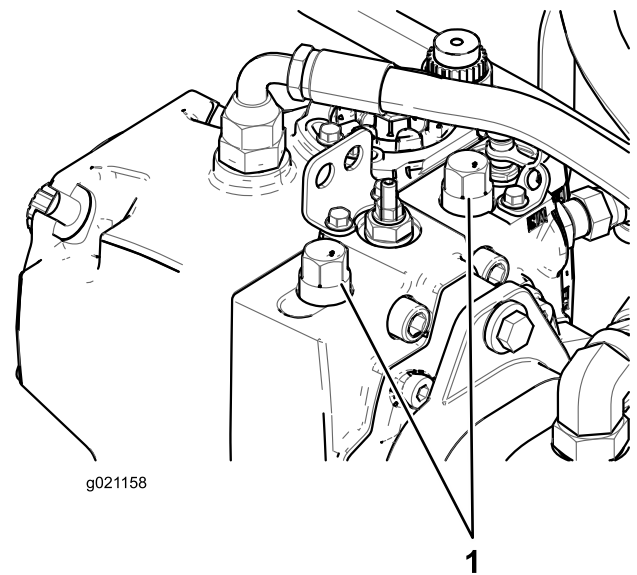

Figure 36

1. Bypass valves (2)

2. Rotate each valve 3 turns counter-clockwise to open and allow oil to bypass internally. Do not open more than 3 turns. Because fluid is bypassed, the machine can be slowly moved without damaging the transmission.
3. Close the bypass valves before starting the engine. Torque to 52 ft-lb (70 N-m) to close the valve.

**Important:** If the machine must be pushed or towed in reverse, the check valve in the four-wheel drive manifold must also be bypassed. To bypass the check valve, connect a hose assembly (Hose Part No. 95-8843, Coupler Fitting No. 95-0985 [Qty. 2], and Hydraulic Fitting No. 340-77 [Qty. 2]) to the reverse traction pressure test port MB, located on the hydrostat, and on the test port G2 on the rear traction manifold which is located behind the front tire.

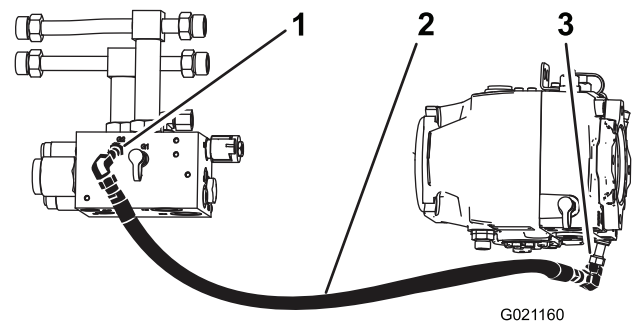
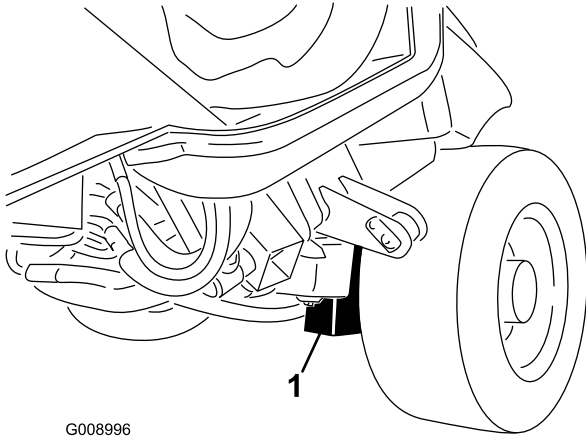

Figure 37

1. Reverse four-wheel drive pressure test port (Port G2)
2. Hose assembly
3. Reverse traction pressure test port (Port MB)

## Jacking Points

- On the front of the machine on the frame on the inside of each drive tire (Figure 38).



G008996

**Figure 38**

1. Front jacking point (2)
- 

- On the rear of the machine at the center of the axle (Figure 39).

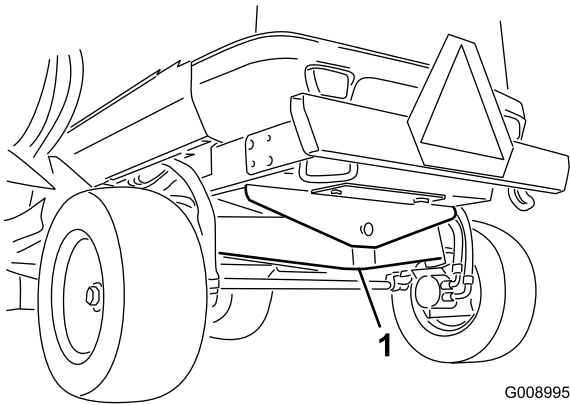

G008995

**Figure 39**

1. Rear jacking point
- 

## Tie Downs

- Under the front of the operator's platform (2 places) (Figure 40).

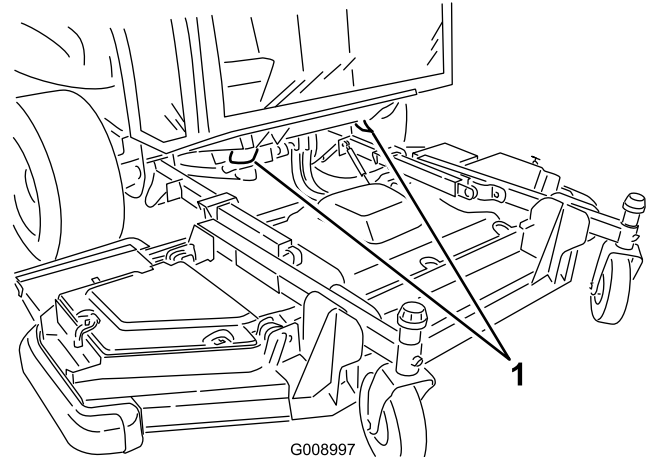

G008997

**Figure 40**

1. Front tie down (2)
- 

- The rear bumper (2 places) (Figure 41).

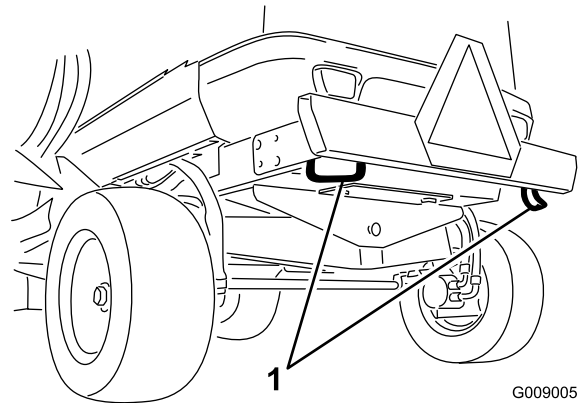

G009005

**Figure 41**

1. Rear tie down (2)
-

# Operating Characteristics

Practice driving the machine because it has a hydrostatic transmission and its characteristics are different than many turf maintenance machines. Some points to consider when operating the traction unit, cutting unit, or other implements are the transmission, engine speed, load on the cutting blades or other implement components, and the importance of the brakes.

To maintain enough power for the traction unit and implement while operating, regulate the traction pedal to keep the engine speed (RPM) high and somewhat constant. A good rule to follow is to decrease the ground speed as the load on the implement increases, and increase the ground speed as the load decreases.

Therefore, allow the traction pedal to move backward as the engine speed (RPM) decreases, and depress the pedal slowly as the engine speed (RPM) increases. By comparison, when driving from one work area to another, with no load and cutting unit raised, have the throttle in the highest position and depress the traction pedal slowly but fully to attain maximum ground speed.

The traction assist enhances traction drive performance in compromised operating conditions. The traction assist is for use in low speed range only. When approaching an area known to cause wheel spin, depress and hold traction assist switch until completely past the area. If a tire spins while climbing or maneuvering on slopes, depress switch and slowly drive out of area. If both a front and rear wheel spins, the steering brake can be feathered to transfer the torque from the spinning wheels to opposite front wheel.

The brakes can be used to assist in turning the machine. However, use them carefully, especially on soft or wet grass because the turf may be torn accidentally. Another benefit of the brakes is to maintain traction. For example, in some slope conditions, the uphill wheel slips and loses traction. If this situation occurs, depress the uphill turn pedal gradually and intermittently until the uphill wheel stops slipping, thus, increasing traction on the downhill wheel.

Use extra care when operating the machine on slopes. Make sure the seat belt is buckled. Drive slowly and avoid sharp turns on slopes to prevent roll overs. For steering control, the cutting unit must be lowered when going downhill.

## **▲ WARNING**

**This product is designed to drive objects into the ground where they lose energy quickly in grass areas. However, careless operation, combined with terrain angle, ricochets, or improperly positioned safety guard can lead to thrown object injuries.**

- When a person or pet appears suddenly in or near the mowing area, *stop mowing*.
- Do not resume mowing until the area is cleared.

Before stopping the engine, disengage all controls and move the throttle to the slowest position. Moving the throttle to the slowest position reduces high engine speed (RPM), noise, and vibration. Turn the key to Off to stop the engine.

Before transporting the machine, raise the cutting units and secure the side cutting unit transport latches (Figure 42).

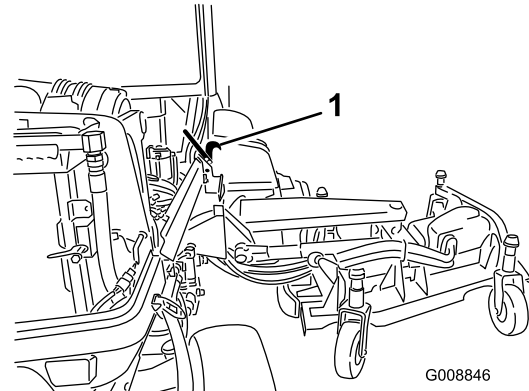

**Figure 42**

1. Transport latch

# Reversing Fan Operation

The fan speed will be controlled by hydraulic oil temperature, air intake temperature and engine coolant temperature. A reverse cycle is automatically initiated and only happens when either the engine coolant or hydraulic oil temperature reaches a certain point. This reversal will help blow debris off the rear screen and lower the engine and hydraulic oil temperatures (Figure 43).



**Figure 43**

# Operating Tips

## Select the Proper Height-of-Cut Setting to Suit Conditions

Remove approximately 1 inch (25 mm) or no more than 1/3 of the grass blade when cutting. In exceptionally lush and dense grass, you may have to raise the height-of-cut to the next setting.

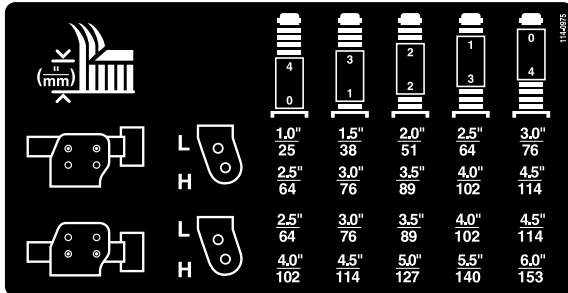

Figure 44

## Mow When Grass is Dry

Mow either in the late morning to avoid the dew, which causes grass clumping, or in late afternoon to avoid the damage that can be caused by direct sunlight on the sensitive, freshly mowed grass.

## Mow at Proper Intervals

Under most normal conditions you will need to mow approximately every 4-5 days. But remember, grass grows at different rates at different times. This means that in order to maintain the same height-of-cut, which is a good practice, you will need to cut more frequently in early spring; as the grass growth rate slows in mid summer, cut only every 8-10 days. If you are unable to mow for an extended period due to weather conditions or other reasons, mow first with the height-of-cut at a high level; then mow again 2-3 days later with a lower height setting.

## Transporting

Use the transport latches when transporting over long distances, rough terrain, or when trailering.

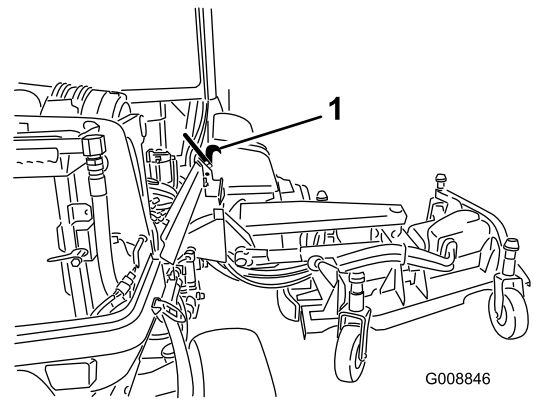

Figure 45

1. Transport latch

## After Operating

To ensure optimum performance, clean the underside of the mower housing after each use. If residue is allowed to build up in the mower housing, cutting performance will decrease.

## Cutting Unit Pitch

Cutting unit pitch is the difference in height-of-cut from the front of the blade plane to the back of the blade plane. A blade pitch of .300 inch (7.6 mm) is recommended. A pitch larger than .300 inch (7.6 mm) will result in less power required, larger clippings, and a poorer quality of cut. A pitch less than .300 inch (7.6 mm) will result in more power required, smaller clippings and a better quality of cut.

## Maximizing Air Conditioner Performance

- To limit solar heating, park the machine in a shaded area or leave the doors open in direct sun.
- Check to make sure the air conditioning screen is clean.
- Check to make sure the air conditioning condenser fins are clean.
- Operate the air conditioner blower at the mid speed setting.
- Verify continuous seal between the roof and the headliner. Correct as required.
- Measure the air temperature at the front center vent in the headliner (Typically stabilize at less than or equal to 50 degrees F.)
- Refer to the Service Manual for additional information

# Maintenance

**Note:** Determine the left and right sides of the machine from the normal operating position.

## Recommended Maintenance Schedule(s)

Maintenance Service Interval	Maintenance Procedure
After the first 10 hours	<ul style="list-style-type: none"> <li>• Torque the wheel lug nuts.</li> <li>• Check the alternator belt tension.</li> <li>• Check the compressor belt tension.</li> <li>• Check blade bolt torque</li> </ul>
After the first 250 hours	<ul style="list-style-type: none"> <li>• Adjust the valve clearance</li> <li>• Change the planetary drive gear/brake oil</li> </ul>
Before each use or daily	<ul style="list-style-type: none"> <li>• Check the tire pressure.</li> <li>• Lubricate castor arm bushings.</li> <li>• Check the engine oil level.</li> <li>• Drain the water separator</li> <li>• Check the coolant level.</li> <li>• Check the hydraulic fluid level.</li> <li>• Check mower blade condition</li> <li>• Check the safety interlock switch operation</li> </ul>
Every 50 hours	<ul style="list-style-type: none"> <li>• Lubricate all grease fittings.</li> <li>• Remove air cleaner cover and clean out debris Do not remove filter.</li> <li>• Check the battery condition</li> <li>• Inspect the blade drive belts.</li> <li>• Check blade bolt torque</li> <li>• Clean the air conditioning screen. (Clean more frequently in extremely dusty or dirty conditions)</li> <li>• Remove all debris and chaff from the engine compartment, radiator and oil cooler.</li> </ul>
Every 100 hours	<ul style="list-style-type: none"> <li>• Inspect the cooling system hoses.</li> </ul>
Every 250 hours	<ul style="list-style-type: none"> <li>• Torque the wheel lug nuts.</li> <li>• Change the engine oil and filter.</li> <li>• Service the spark arrestor.</li> <li>• Clean the cab air filters. (Clean more frequently in extremely dusty or dirty conditions and replace them if they are torn or excessively dirty.)</li> <li>• Clean the air conditioning coil. (Clean more frequently in extremely dusty or dirty conditions)</li> </ul>
Every 400 hours	<ul style="list-style-type: none"> <li>• Check the planetary drive gear/brake oil level (Also, check if external leakage is observed)</li> </ul>
Every 500 hours	<ul style="list-style-type: none"> <li>• Inspect the fuel lines and connections.</li> <li>• Replace the fuel/water separator element.</li> <li>• Replace the fuel filter element</li> <li>• Inspect the cutting unit castor wheel assemblies.</li> </ul>
Every 800 hours	<ul style="list-style-type: none"> <li>• Change the planetary drive gear/brake oil (Or yearly, whichever comes first)</li> </ul>
Every 1,000 hours	<ul style="list-style-type: none"> <li>• Drain and clean the fuel tank.</li> <li>• Recalibrate traction pedal</li> <li>• Check the rear wheel toe-in.</li> <li>• Check the alternator belt tension.</li> <li>• Check the compressor belt tension.</li> <li>• Replace the drive blade belts</li> <li>• Change the hydraulic fluid and filters.</li> </ul>
Every 2,000 hours	<ul style="list-style-type: none"> <li>• Adjust the valve clearance</li> </ul>
Every 2 years	<ul style="list-style-type: none"> <li>• Flush the cooling system and replace fluid.</li> <li>• Replace moving hoses.</li> </ul>

## ⚠ CAUTION

If you leave the key in the ignition switch, someone could accidentally start the engine and seriously injure you or other bystanders.

Remove the key from the ignition before you do any maintenance.

## Service Interval Chart

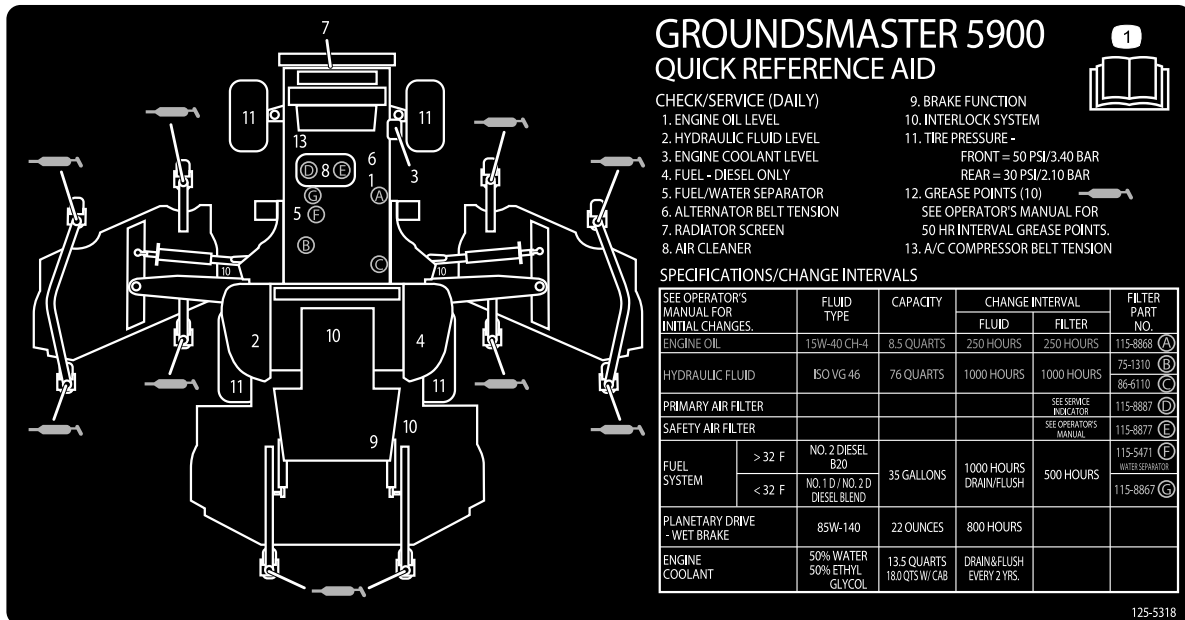

Figure 46

## Premaintenance Procedures

### Inner Wing Deck Covers

#### Removal

1. Lower the wing deck onto a level surface.
2. Disengage the cover latch.
3. Remove the bolt securing the belt cover, if so equipped.
4. Lift the rear and inside cover edges off the mounting posts (Figure 47).

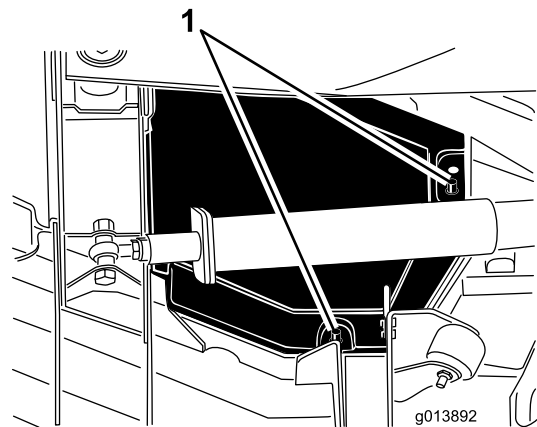
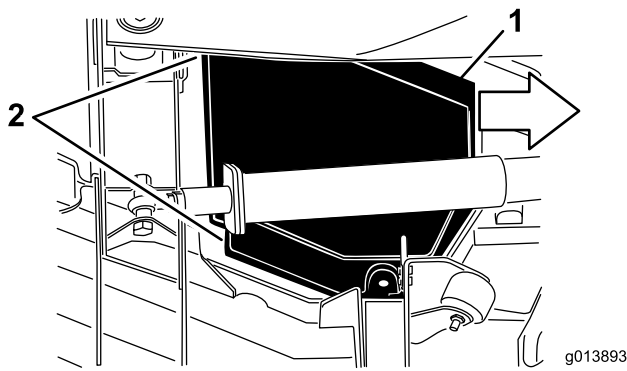

Figure 47

1. Mounting posts

5. While lifting the cover, slide it toward the traction unit, approximately 1 inch, to disengage the outer cover edge from the deck (Figure 48).



**Figure 48**

1. Slide cover inward approximately 1 inch
2. Disengage these cover edges

6. Lift the front edge, guide it between the lift arm and the roller to remove it (Figure 49).

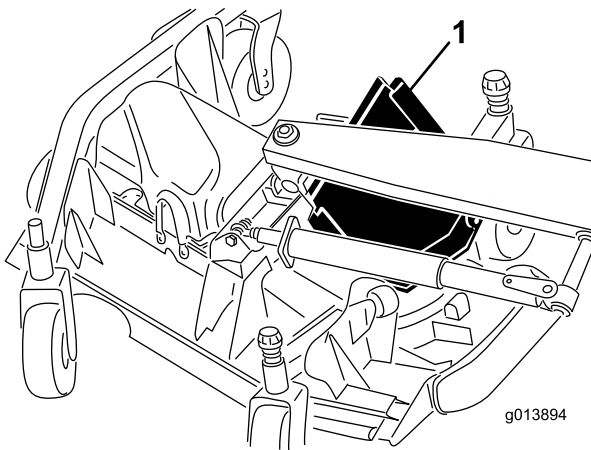

**Figure 49**

1. Slide cover out between lift arm and roller

## Installation

1. Lower the wing deck onto a level surface.
2. Slide the cover into position by guiding the rear edge between the lift arm and roller.
3. While sliding the cover away from the traction unit, guide the outside edge under the front and rear brackets on the deck.
4. Align the deck mounting posts with the holes in the cover and lower the cover into position.
5. Install the bolt securing the belt cover, if so equipped.
6. Engage the deck cover latch.

## Lubrication

### Greasing the Bearings and Bushings

**Service Interval:** Before each use or daily—Lubricate castor arm bushings.

Every 50 hours—Lubricate all grease fittings.

The machine has grease fittings that must be lubricated regularly with No. 2 General Purpose Lithium Base Grease. If the machine is operated under normal conditions, lubricate all bearings and bushings after every 50 hours of operation or immediately after every washing.

**Note:** The castor fork shaft bushings must be lubricated before each use or daily

The grease fitting locations and quantities are:

### Traction Unit

- Impact arms (2) (Figure 50)
- Front Deck Lift cylinder pivots (2) (Figure 50)
- Side Deck Lift cylinder pivots (2) (Figure 50)
- Steering cylinder ball joints (4) (Figure 51)
- Tie rod ball joints (2) (Figure 51)
- King pin bushings (2) (Figure 51)
- Rear axle pivot bushing (1) (Figure 52)
- Brake shaft pivot bearings (1) (Figure 53)

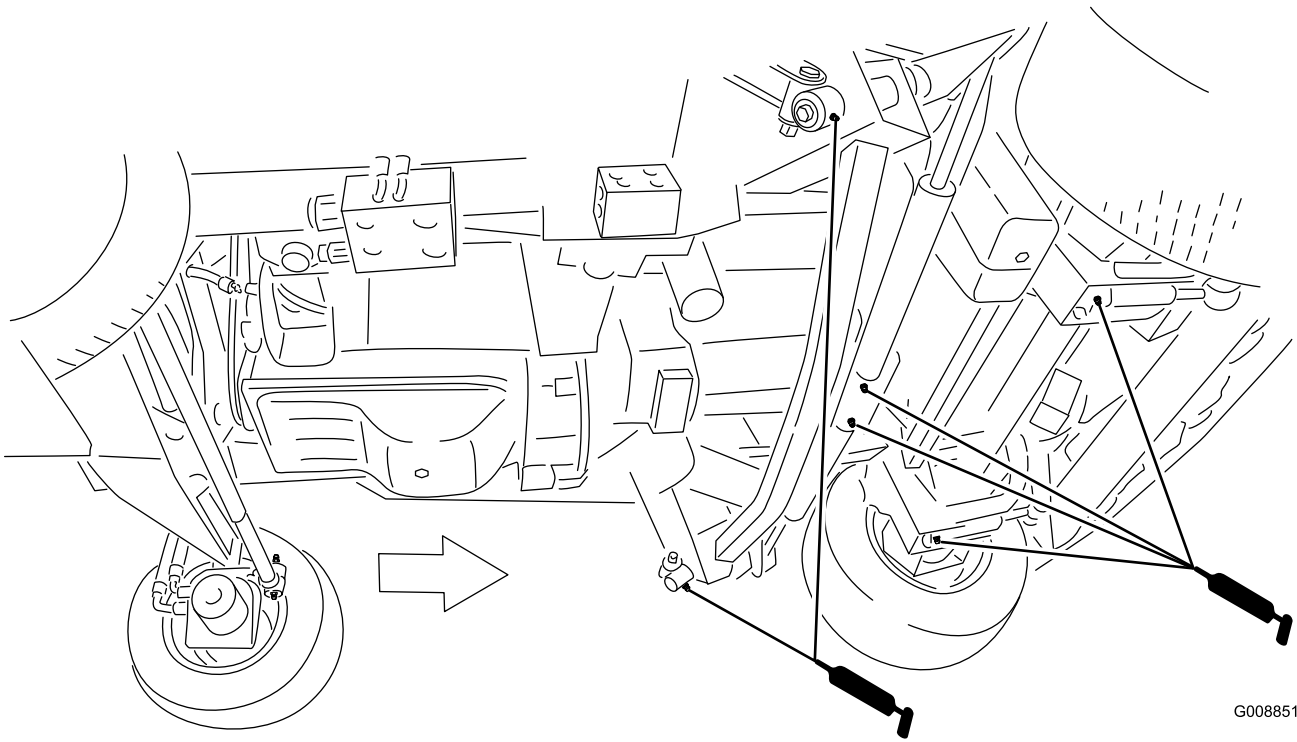

G008851

**Figure 50**

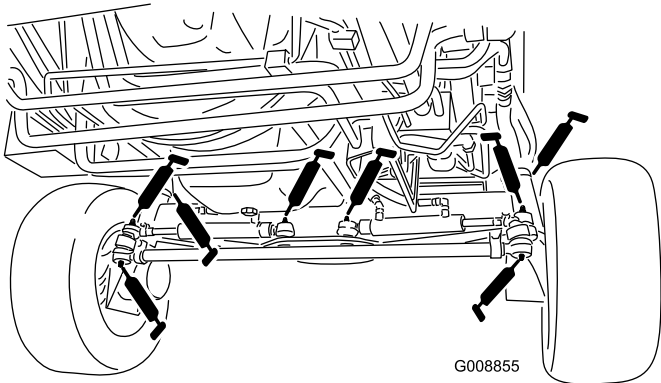

G008855

**Figure 51**

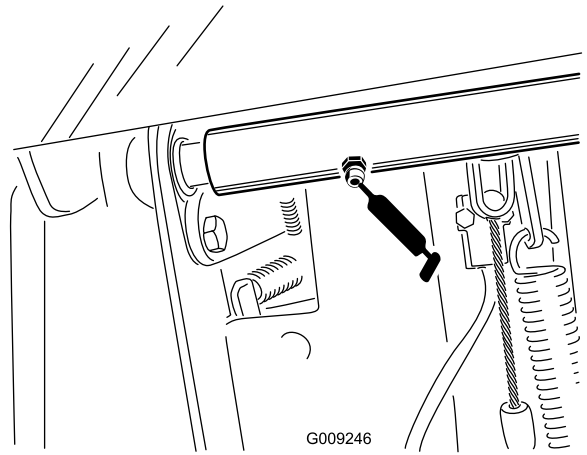

G009246

**Figure 53**

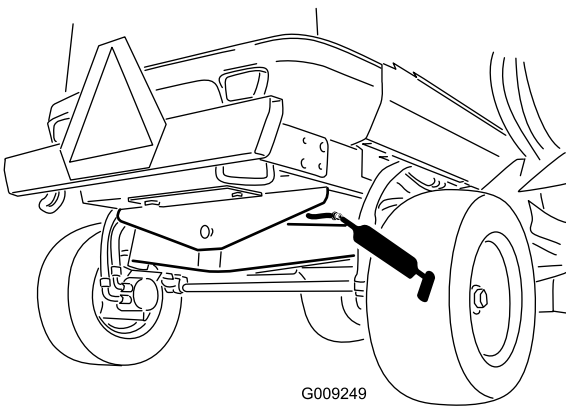

G009249

**Figure 52**

## Front Cutting Unit

- Castor fork shaft bushings (2) (Figure 54)
- Spindle shaft bearings (5) (located on spindle housing) (Figure 54)
- Idler arm pivot bushings (3) (located on the idler pivot shaft) (Figure 54)

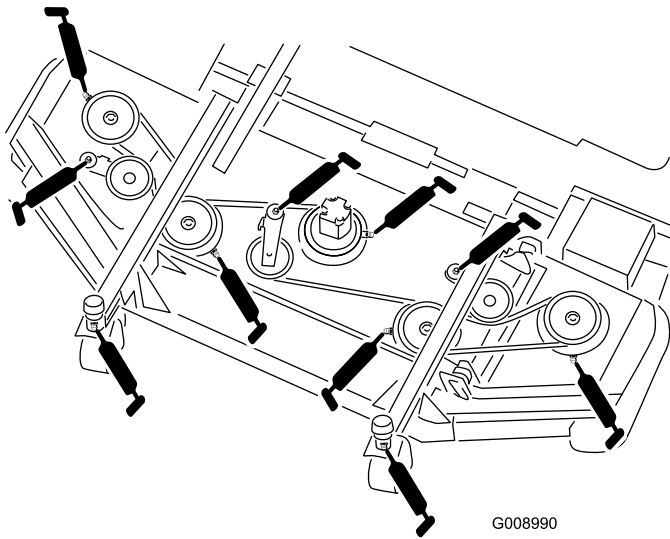

**Figure 54**

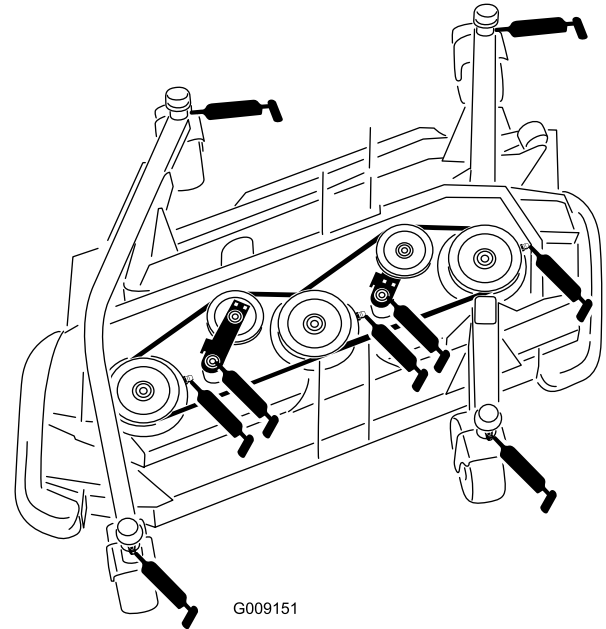

**Figure 56**

### Front Lift Assemblies

- Lift arm bushings (2) (Figure 55)
- Lift arm ball joints (2) (Figure 55)
- Front Deck Lift cylinder pivots (2) (Figure 55)

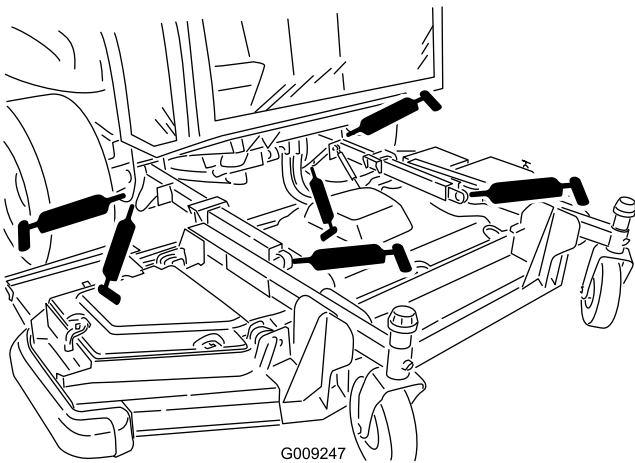

**Figure 55**

### Side Lift Assemblies (per side)

- Main lift arm bushings (3) (Figure 57)
- Lift cylinder bushings (1) (Figure 57)
- 

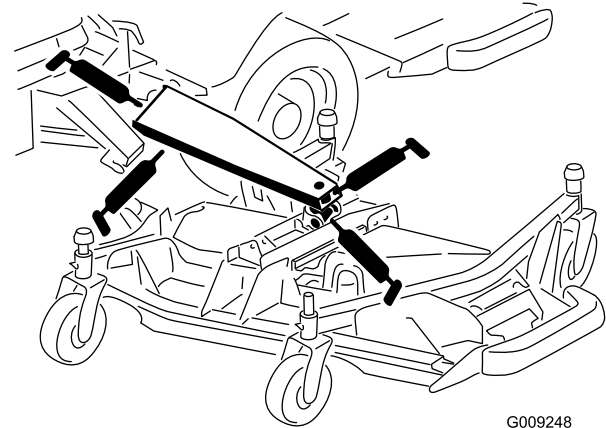

**Figure 57**

### Side Cutting Units (per side)

- Castor fork shaft bushing (4) (Figure 56)
- Spindle shaft bearings (3 each) (located on spindle housing) (Figure 56)
- Idler arm pivot bushings (2) (located on the idler pivot shaft) (Figure 56)

# Engine Maintenance

## Air Cleaner Maintenance

- Check the air cleaner body for damage which could cause an air leak. Replace if damaged. Check the whole intake system for leaks, damage or loose hose clamps. Also, inspect the rubber intake hose connections at the air cleaner and turbo to make sure the connections are complete.
- Service the air cleaner filter only when “Check Air Filter” is displayed on the Info Center (Figure 58). Changing the air filter before it is necessary only increases the chance of dirt entering the engine when the filter is removed.



Figure 58

g021157

- Be sure the cover is seated correctly and seals with the air cleaner body.

## Servicing the Air Cleaner Cover

**Service Interval:** Every 50 hours—Remove air cleaner cover and clean out debris. Do not remove filter.

Check the air cleaner body for damage which could cause an air leak. Replace a damaged air cleaner body.

Service the air cleaner filter only when “Check Air Filter” is displayed on the Info Center (Figure 58). Changing the air filter before it is necessary only increases the chance of dirt entering the engine when the filter is removed.

1. Pull the latch outward and rotate the air cleaner cover counterclockwise (Figure 59).
2. Remove the cover from the air cleaner body.
3. Clean any debris from cover and reinstall cover. Do not remove air filters.

## Servicing the Air Cleaner Filter

1. Before removing the filter, use low pressure air (40 psi, clean and dry) to help remove large accumulations of debris packed between outside of primary filter and the canister. Avoid using high pressure air which could force dirt through the filter into the intake tract. This

cleaning process prevents debris from migrating into the intake when the primary filter is removed.

2. Remove the primary filter (Figure 59). Cleaning of the used element is not recommended due to the possibility of damage to the filter media. Inspect the new filter for shipping damage, checking the sealing end of the filter and the body. Do not use a damaged element. **Do not** remove the safety filter (Figure 60).

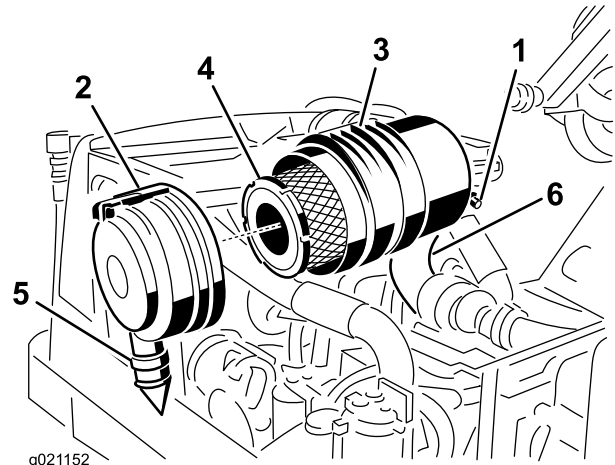

Figure 59

- |                            |                               |
|----------------------------|-------------------------------|
| 1. Air cleaner restriction | 4. Air cleaner primary filter |
| 2. Air cleaner latch       | 5. Rubber outlet valve        |
| 3. Air cleaner body        | 6. Rubber intake hose         |

**Important:** Never attempt to clean the safety filter (Figure 60). Replace the safety filter with a new one after every three primary filter services.

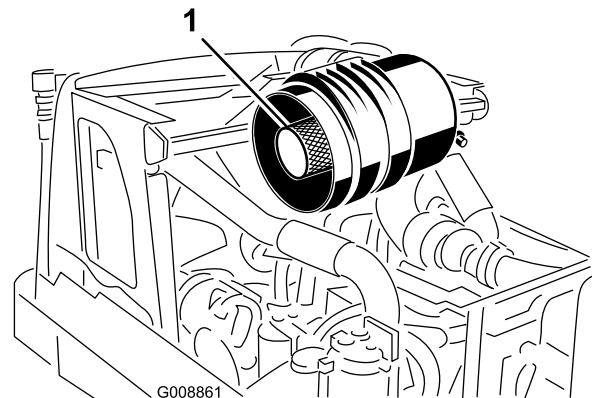

Figure 60

1. Safety filter
3. Replace the primary filter (Figure 59).
4. Insert the new filter by applying pressure to the outer rim of the element to seat it in the canister. Do not apply pressure to the flexible center of the filter.
5. Clean the dirt ejection port located in the removable cover. Remove the rubber outlet valve from the cover, clean the cavity and replace the outlet valve.

- Install the cover orienting the rubber outlet valve (Figure 59) in a downward position - between approximately 5:00 to 7:00 when viewed from the end. Secure the latch.

## Servicing the Engine Oil

### Checking the Engine Oil Level

**Service Interval:** Before each use or daily—Check the engine oil level.

The engine is shipped with oil in the crankcase; however, the oil level must be checked before and after the engine is first started.

The crankcase capacity is 8.5 qt (8.04 l) with the filter.

Use high-quality engine oil that meets the following specifications:

- API Classification Level Required: CH-4, CI-4 or higher.
- Preferred oil: SAE 15W-40 (above 0°F)
- Alternate oil: SAE 10W-30 (below 23°F)

Toro Premium Engine Oil is available from your distributor in either 15W-40 or 10W-30 viscosity. See the parts catalog for part numbers. Also, refer to the *Engine Operator's Manual*, included with the machine, for further recommendations.

**Note:** The best time to check the engine oil is when the engine is cool before it has been started for the day. If it has already been run, allow the oil to drain back down to the sump for at least 10 minutes before checking. If the oil level is at or below the 'add' mark on the dipstick, add oil to bring the oil level to the 'full' mark. **Do not overfill.** If the oil level is between the 'full' and 'add' marks, no oil addition is required.

- Park the machine on a level surface.
- Remove the dipstick (Figure 61), wipe it clean, install the dipstick into the tube, and pull it out again. The oil level should be up to the Full mark.

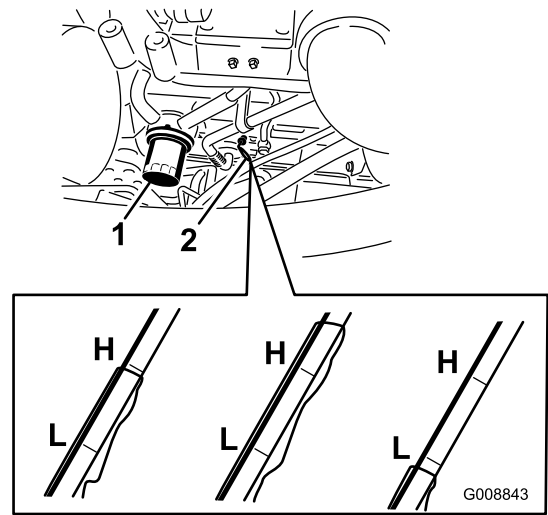

**Figure 61**

- Oil filter
- Dipstick

- If the oil is below the Low mark, remove the fill cap (Figure 62) and add oil until the level reaches the Full mark. **Do not overfill.**

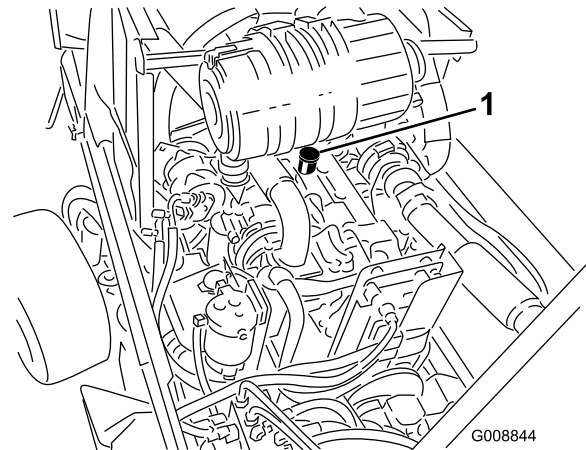

**Figure 62**

- Oil fill cap

- Install the oil fill cap and dipstick.

### Changing the Engine Oil

**Service Interval:** Every 250 hours—Change the engine oil and filter.

- Remove the drain plug (Figure 63) and let the oil flow into a drain pan. When the oil stops, install the drain plug.

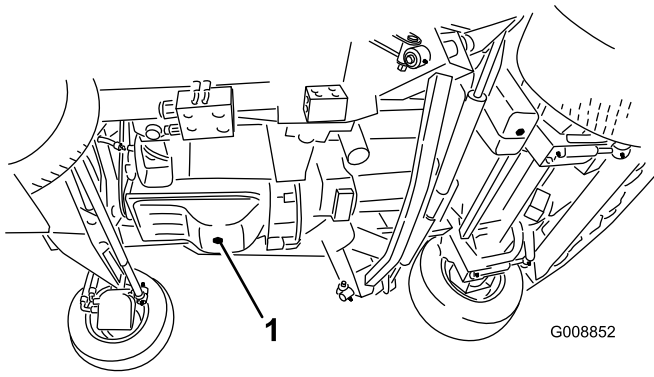

**Figure 63**

1. Engine oil drain plug
- 
2. Remove the oil filter (Figure 61). Apply a light coat of clean oil to the new filter seal before screwing it on. **Do not overtighten.**
  3. Add oil to the crankcase; refer to Checking the Engine Oil.

## Adjusting the Valve Clearance

**Service Interval:** After the first 250 hours—Adjust the valve clearance

Every 2,000 hours—Adjust the valve clearance

Refer to the Engine Operator's Manual, included with the machine, for the adjusting procedure.

# Fuel System Maintenance

## Servicing the Fuel System

### **⚠ DANGER**

Under certain conditions, diesel fuel and fuel vapors are highly flammable and explosive. A fire or explosion from fuel can burn you and others and can cause property damage.

- Use a funnel and fill the fuel tank outdoors, in an open area, when the engine is off and is cold. Wipe up any fuel that spills.
- Do not fill the fuel tank completely full. Add fuel to the fuel tank until the level is 1 inch (25 mm) below the bottom of the filler neck. This empty space in the tank allows the fuel to expand.
- Never smoke when handling fuel, and stay away from an open flame or where fuel fumes may be ignited by a spark.
- Store fuel in a clean, safety-approved container and keep the cap in place.

## Fuel Tank

**Service Interval:** Every 1,000 hours—Drain and clean the fuel tank.

Drain and clean the fuel tank every 1000 hours. Also, drain and clean the tank if fuel system becomes contaminated or if the machine will be stored for an extended period of time. Use clean fuel to flush out the tank.

## Fuel Lines and Connections

**Service Interval:** Every 500 hours—Inspect the fuel lines and connections.

Check the fuel lines and connections every 500 hours or yearly, whichever comes first. Inspect them for deterioration, damage, or loose connections.

## Servicing the Water Separator

**Service Interval:** Before each use or daily—Drain the water separator

Every 500 hours—Replace the fuel/water separator element.

## Draining the Water Separator

1. Place a clean container under the water separator (Figure 64).
2. Open the drain plug and operate the pump to drain off contaminants (Figure 64).

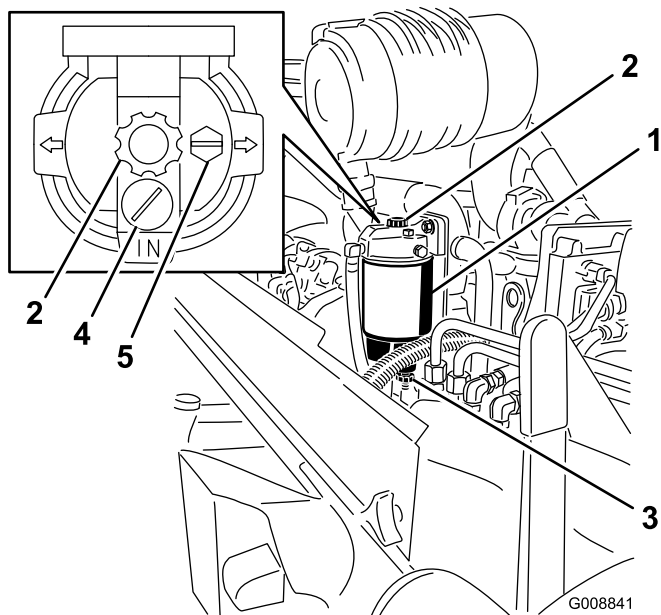

**Figure 64**

- |                                    |                     |
|------------------------------------|---------------------|
| 1. Water separator filter canister | 4. Flow check valve |
| 2. Priming pump                    | 5. Vent plug        |
| 3. Drain plug                      |                     |

3. Close the drain plug.

## Replacing the Fuel Filter Element

1. Place a clean container under the water separator.
2. Drain some fuel by loosening the vent plug and opening the drain plug (Figure 64).
3. Disconnect the water sensor (electrical connector) from the bottom of the water separator
4. Clean the area where the filter element mounts to the head.
5. Remove the filter element and bowl. Remove the element from the bowl and clean the mounting surface.
6. Clean the O-ring gland on the bowl.
7. Apply a coating of clean fuel or motor oil to the new O-ring and element seal.
8. Spin the bowl onto the new element and then spin them both onto the filter head by hand only. **Do not use tools.**
9. Close the drain plug.
10. Connect the water sensor (electrical connector) from the bottom of the water separator.
11. With the vent plug still loosened, operate the primer pump until fuel purges at the vent plug. Close the vent plug, start the engine and check for leaks. Correct as necessary with the engine off.

## Replacing the Fuel Filter

**Service Interval:** Every 500 hours—Replace the fuel filter element

1. Clean the area around the fuel filter head (Figure 65).

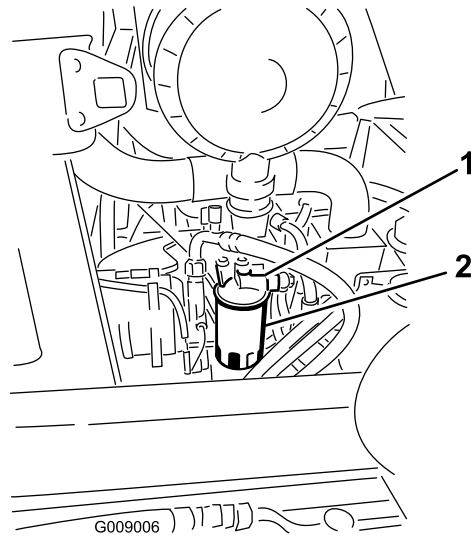

**Figure 65**

- |                     |           |
|---------------------|-----------|
| 1. Fuel filter head | 2. Filter |
|---------------------|-----------|

2. Remove the filter and clean the filter head mounting surface (Figure 65).
3. Lubricate the filter gasket with clean lubricating engine oil. Refer to the Engine Operator's Manual, included with the machine, for additional information.
4. Install the dry filter canister, by hand, until the gasket contacts the filter head, then rotate it an additional 1/2 turn.
5. Loosen the banjo fitting on the fuel filter housing (Figure 66).

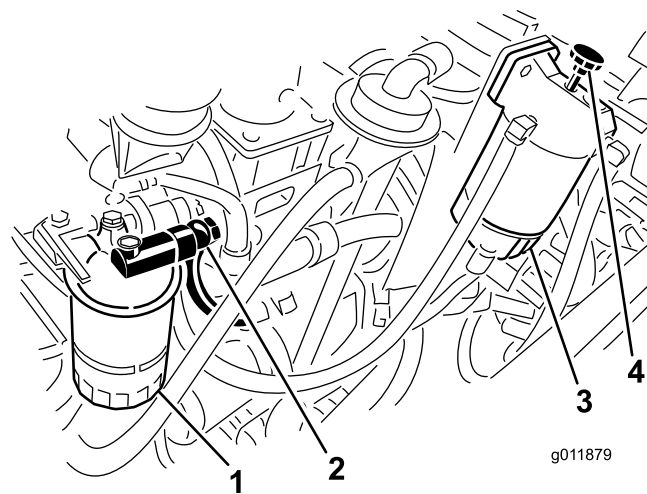

**Figure 66**

- |                  |                    |
|------------------|--------------------|
| 1. Fuel filter   | 3. Water Separator |
| 2. Banjo fitting | 4. Priming pump    |

6. Operate the water separator priming pump until a solid stream of fuel is detected at the banjo fitting (Figure 66).
7. Tighten the fuel filter banjo fitting.
8. Push down the priming pump and turn it clockwise to secure.
9. Start the engine and check for fuel leaks around the filter head.

# Electrical System Maintenance

## ⚠ WARNING

If installing an auxiliary accessory to the machine, the only approved locations to source power are the traction unit fuse block (Figure 69) or the cab fuse block (Figure 71). A maximum of 10 amps is available from either location. Contact your local Toro distributor for assistance.

**Note:** Make sure the key is off and removed from the switch before removing fuses.

## Fuses

The traction unit fuses (Figure 69) are located in the power center console (Figure 68).

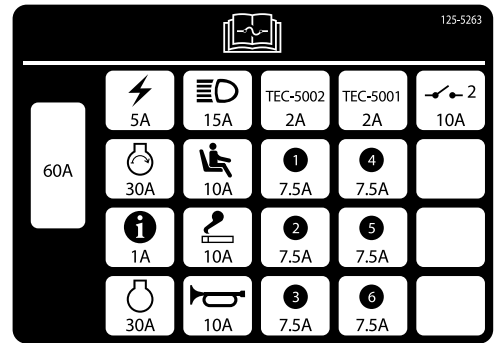

g021155

Figure 67

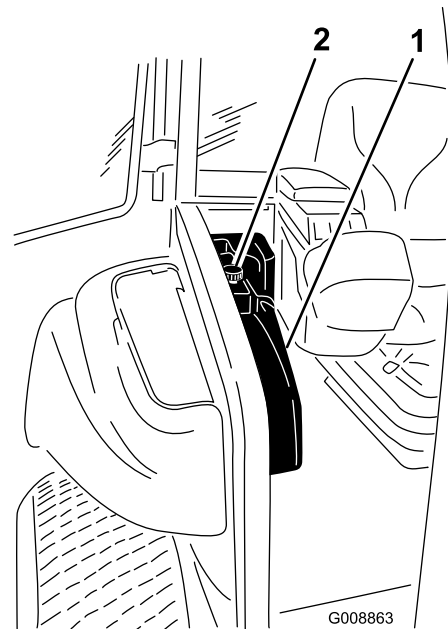

Figure 68

1. Power center console
2. Knob

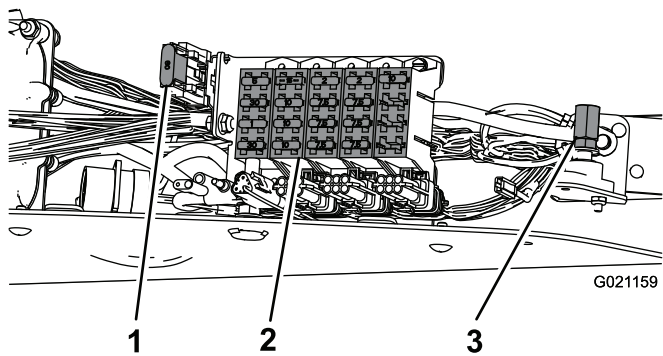

Figure 69

- 1. Fuse-60 AMP
- 2. Fuse block
- 3. Alternate positive post for charging or jump starting

## Battery Care

**Service Interval:** Every 50 hours—Check the battery condition

### WARNING

#### CALIFORNIA Proposition 65 Warning

Battery posts, terminals, and related accessories contain lead and lead compounds, chemicals known to the State of California to cause cancer and reproductive harm. Wash hands after handling.

The cab fuses are located in the fuse box on the cab headliner (Figure 71).

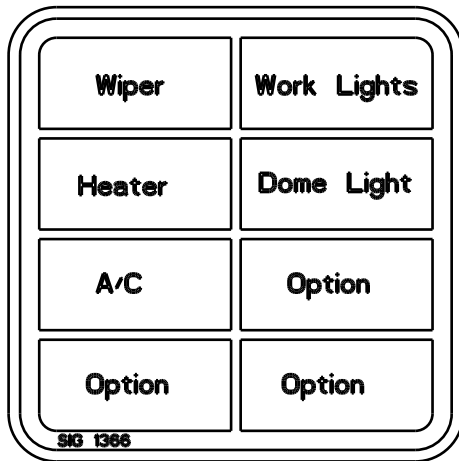

Figure 70

**Important:** Before welding on the machine, disconnect the negative cable from the battery to prevent damage to the electrical system. Also, the engine, InfoCenter and machine controllers must be disconnected before welding on the machine.

**Note:** Check the battery condition weekly or after every 50 hours of operation. Keep the terminals and the entire battery case clean because a dirty battery will discharge slowly. To clean the battery, wash the entire case with a solution of baking soda and water. Rinse with clear water. Coat the battery posts and cable connectors with Grafo 112X (skin-over) grease (Toro Part No. 505-47) or petroleum jelly to prevent corrosion.

## Jump Starting / Battery Charging

If the machine needs to be jump started or the batteries need to be charged, the alternate positive post can be used instead of the positive battery post (Figure 69). The alternate positive post is located in the front of the power center console (Figure 68).

## Recalibrate Traction Pedal

**Service Interval:** Every 1,000 hours—Recalibrate traction pedal

Contact your local Toro distributor or refer to the Toro Service Manual for the assistance.

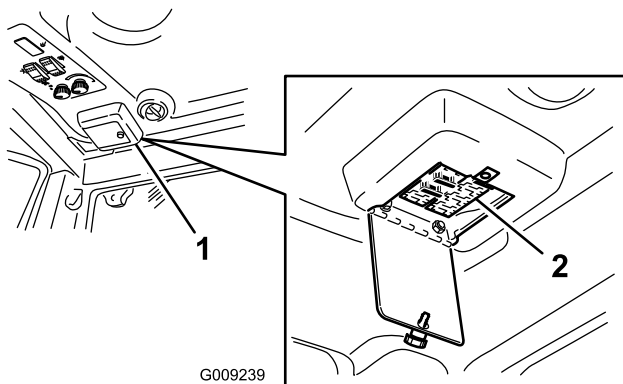

Figure 71

- 1. Cab fuse box
- 2. Fuses

# Drive System Maintenance

## Adjusting the Traction Pedal Angle

The traction pedal operating angle can be adjusted for operator comfort.

1. Loosen the two nuts and bolts securing the left side of the traction pedal to the bracket (Figure 72).

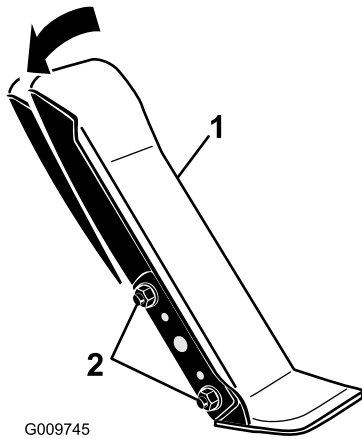

Figure 72

1. Traction pedal
2. Mounting nuts and bolts (2)

2. Pivot the pedal to the desired operating angle and tighten the nuts (Figure 72).

## Checking the Planetary Drive Gear/Brake Oil

**Service Interval:** Every 400 hours—Check the planetary drive gear/brake oil level (Also, check if external leakage is observed)

Check the oil level after every 400 hours of operation or if external leakage is noted. Use high quality SAE 85W-140 gear lube as a replacement.

1. With the machine on a level surface, position the wheel so that one check plug (Figure 73) is at the 12 o'clock position and the other is at 3 o'clock position.

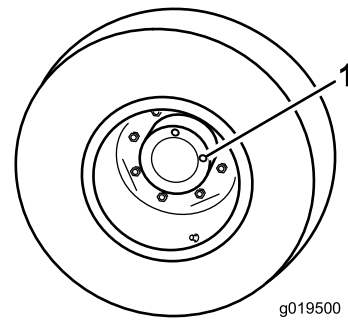

Figure 73

1. Check/drain plug (3 o'clock position)
2. Remove the plug at the 3 o'clock position (Figure 73). Oil level should be at the bottom of the check plug hole
3. If the oil level is low, remove the plug at the 12 o'clock position and add oil until it begins to flow out of the hole at the 3 o'clock position.
4. Re-install both plugs.
5. Repeat steps 1-3 on the opposite planetary gear assembly.

## Changing the Planetary Drive Gear/Brake Oil

**Service Interval:** After the first 250 hours—Change the planetary drive gear/brake oil

Every 800 hours

Change the oil initially after first 250 hours of operation. Thereafter change the oil every 800 hours, or yearly, whichever occurs first. Use a high quality SAE 85W-140 gear lube as replacement.

1. With machine on level surface, position a wheel so one of the check/drain plugs is at the lowest (6 o'clock) position (Figure 74).

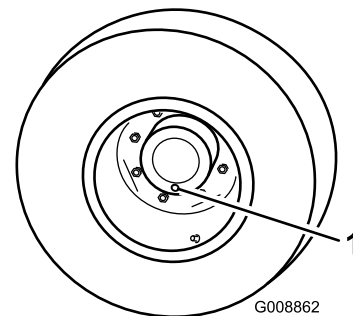
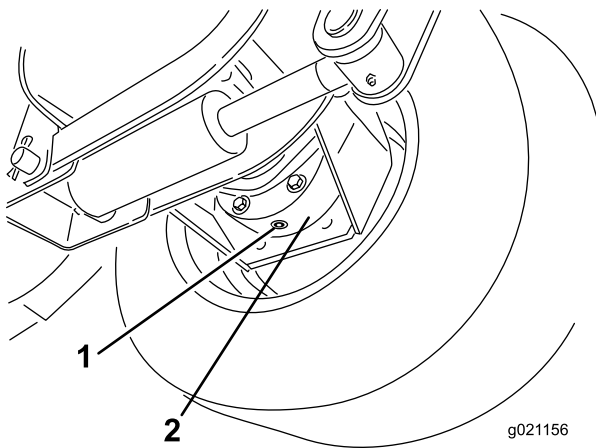

Figure 74

1. Check/drain plug
2. Place a drain pan under the planetary hub, remove plug and allow oil to drain.
3. Place a drain pan under the brake housing, remove the drain plug and allow the oil to drain (Figure 75).



**Figure 75**

1. Drain plug
2. Brake housing

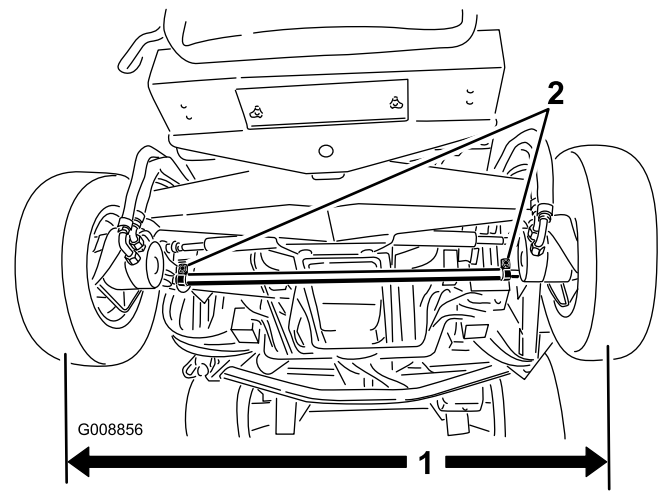

**Figure 76**

1. Center to center distance
2. Tie rod clamps

4. When all of the oil has drained from both locations, re-install the plug in the brake housing.
5. Rotate the wheel until the open plug hole in the planetary is at the twelve o'clock position.
6. Through the open hole, slowly fill the planetary with 22 ounces. (0.65 liter) of high quality SAE 85W-140 wt. gear lube.

**Important:** If the planetary fills before the 22 ounces (0.65 liter) of oil is added, wait one hour or install the plug and move the machine approximately ten feet to distribute the oil through the brake system. Then, remove the plug and add the remaining oil.

7. Reinstall the plug.
8. Repeat the procedure on the opposite planetary/brake assembly

2. To adjust, loosen the clamps at both ends of the tie rods (Figure 76).
3. Rotate the tie rod end to move the front of the tire inward or outward.
4. Tighten the tie rod clamps when the adjustment is correct.

## Checking the Rear Wheel Toe-In

**Service Interval:** Every 1,000 hours—Check the rear wheel toe-in.

After every 1000 operating hours or annually, check the rear wheel toe-in.

1. Measure the center-to-center distance (at axle height) at the front and rear of the steering tires (Figure 76). The front measurement must be no greater than 0.00”-0.12’ less than the rear measurement.

# Cooling System Maintenance

## ⚠ CAUTION

Discharge of hot pressurized coolant or touching hot radiator and surrounding parts can cause severe burns.

- Do not remove the radiator cap when the engine is hot. Always allow the engine to cool at least 15 minutes or until the radiator cap is cool enough to touch without burning your hand before removing the radiator cap.
- Do not touch radiator and surrounding parts that are hot.

## ⚠ DANGER

Swallowing engine coolant can cause poisoning.

- Do not swallow engine coolant.
- Keep out of reach from children and pets.

## Checking the Cooling System

**Service Interval:** Before each use or daily—Check the coolant level.

Check level of coolant at the beginning of each day. Capacity of the system on a machine without a cab is 13.5 quarts (10.4 l) and with a cab is 18 quarts (17 l).

### Recommended Coolant

**Note:** Coolant must meet or exceed ASTM Standard 3306

Glycol based pre-diluted coolant (50/50 blend)

or

Glycol based coolant mixed with **distilled** water (50/50 blend)

or

Glycol based coolant mixed with good quality water (50/50 blend) as listed in the Cummins Manual

$\text{CaCO}_3 + \text{MgCO}_3 < 170 \text{ ppm}$

Chloride  $< 40 \text{ ppm (Cl)}$

Sulfur  $< 100 \text{ ppm (SO}_4)$

## ⚠ DANGER

The rotating fan and drive belt can cause personal injury.

- Do not operate the machine without the covers in place.
- Keep fingers, hands and clothing clear of rotating fan and drive belt.
- Shut off the engine and remove the ignition key before performing maintenance.

1. Carefully remove the radiator cap and expansion tank cap (Figure 77).

## ⚠ CAUTION

If the engine has been running, the pressurized, hot coolant can escape and cause burns.

- Do not open the radiator cap when the engine is running.
- Use a rag when opening the radiator cap, and open the cap slowly to allow steam to escape.

2. Check the coolant level in the radiator. The radiator should be filled to the top of the filler neck and the expansion tank filled to the Full mark.

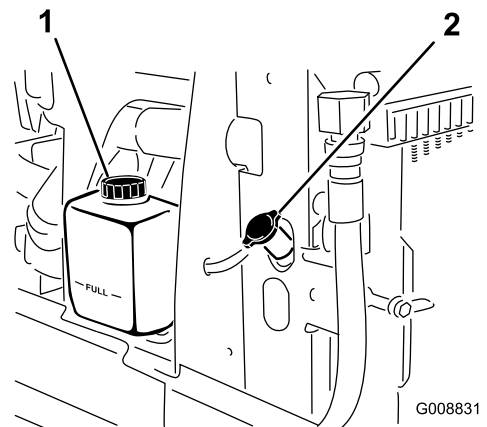

Figure 77

1. Expansion tank
2. Radiator cap

3. If the coolant is low, add recommended replacement coolant, as required. **Do not use water only or alcohol/methanol base coolants.**
4. Install the radiator cap and expansion tank cap.

# Servicing the Engine Cooling System

**Service Interval:** Every 100 hours—Inspect the cooling system hoses.

Every 2 years—Flush the cooling system and replace fluid.

**Remove debris and chaff from the engine compartment, oil cooler and radiator daily.** Clean more frequently in dusty and dirty conditions, if required.

1. Turn the engine off and raise the hood. Clean the engine area thoroughly of all debris.
2. Rotate the latches (Figure 78) securing the oil cooler to the frame.

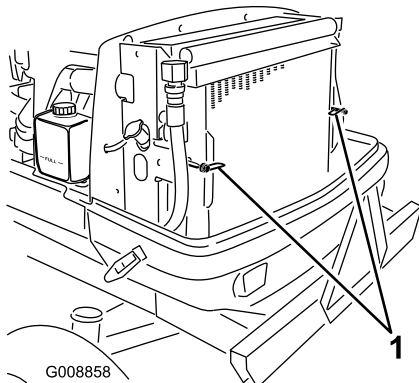

**Figure 78**

1. Latches

3. Pivot the oil cooler rearward. Clean both sides of the oil cooler and radiator area thoroughly with compressed air. Start from the fan side and blow the debris out towards the back. Then clean from the back side and blow towards the front. Repeat procedure several times until all chaff and debris is removed.

**Important:** Cleaning the radiator or oil cooler with water can promote premature corrosion and damage to components.

4. Pivot the oil cooler back into position. Secure it to the frame with the latches and close the hood.

# Brake Maintenance

## Adjusting the Service Brakes

Adjust the service brakes when there is more than 2 inches (50 mm) of “free travel” of the brake pedal, or when the brakes do not work effectively. Free travel is the distance the brake pedal moves before braking resistance is felt.

1. Disengage the locking latch from the brake pedals so that both pedals work independently of each other.
2. To reduce free travel of the brake pedals, adjust the brake cables as follows:
  - A. Loosen the front nut on the threaded end of the brake cable.

**Note:** To allow easier access to the adjusting nuts, the spring may be unhooked and removed.

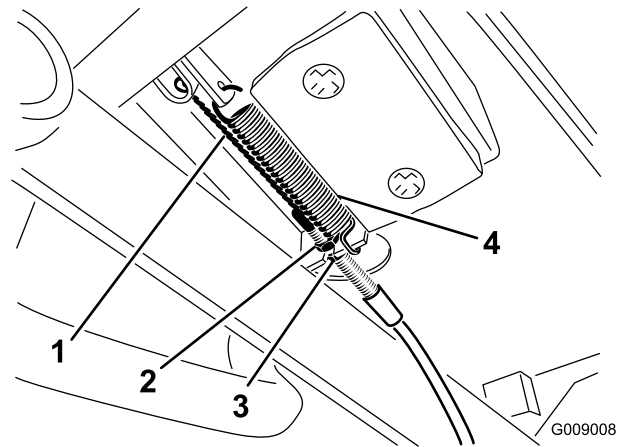

**Figure 79**

1. Brake cable
2. Front nut
3. Rear nut
4. Spring

- B. Tighten the rear nut until the brake pedals have 2 inches (50 mm) of free travel.
- C. Repeat the procedure on the other brake cable.
- D. Tighten the front nuts after the brakes are adjusted correctly.
- E. Reinstall the springs, if removed.

**Important:** Adjusting the brake tension too tight will decrease the life of the friction pad material.

# Belt Maintenance

## Servicing the Alternator Belt

**Service Interval:** After the first 10 hours—Check the alternator belt tension.

Every 1,000 hours—Check the alternator belt tension.

Refer to the Engine Operator's Manual, included with the machine, for the servicing procedure.

## Servicing the Compressor Belt

**Service Interval:** After the first 10 hours—Check the compressor belt tension.

Every 1,000 hours—Check the compressor belt tension.

### Model 31599 only

1. Loosen the compressor pivot bolt and adjusting bolt (Figure 80).
2. Insert a torque wrench into the square hole in the compressor bracket (Figure 80).

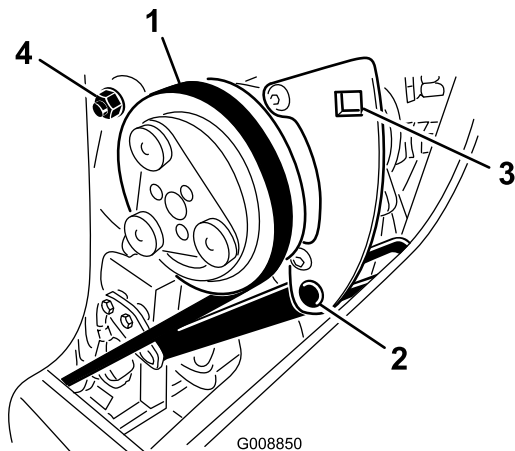

Figure 80

- |                    |                |
|--------------------|----------------|
| 1. Compressor belt | 3. Square hole |
| 2. Mounting bolt   | 4. Pivot bolt  |

3. Rotate the wrench until a torque of 27–33 ft-lb (37–45 N·m) is attained.
4. Tighten the mounting bolts.

## Replacing the Blade Drive Belts

**Service Interval:** Every 50 hours—Inspect the blade drive belts.

Every 1,000 hours—Replace the drive blade belts

The blade drive belt, tensioned by the spring loaded idler pulley, is very durable. However, after many hours of use, the belt will show signs of wear. Signs of a worn belt are:

squealing when belt is rotating, blades slipping when cutting grass, frayed edges, burn marks and cracks. Replace the belt if any of these conditions are evident.

## Front Cutting Unit

1. Lower the cutting unit to the shop floor. Remove the belt covers from the top of the cutting unit and set the covers aside.
2. On the front deck, loosen the jam nuts on the idler pulley stop screw and thread the stop screw in to the bracket (Figure 81).
3. Using a ratchet wrench or similar tool, move the idler pulley (Figure 81) away from the drive belt to release the belt tension and allow the belt to be slipped off the deck pulleys.

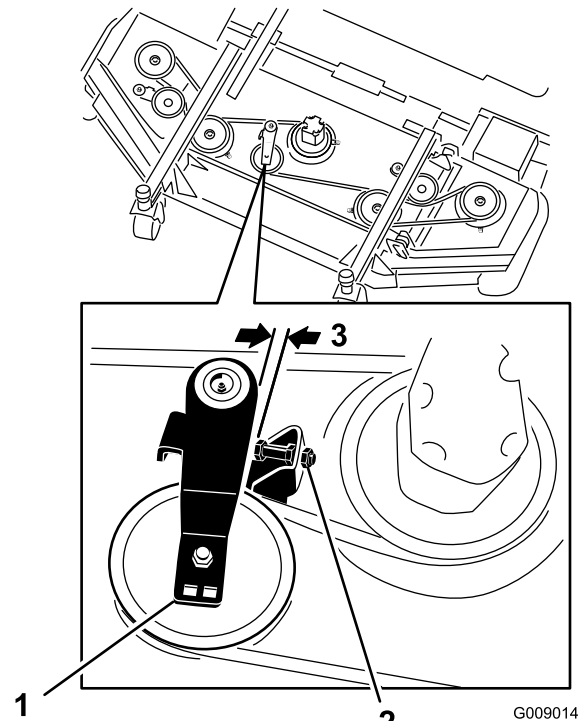
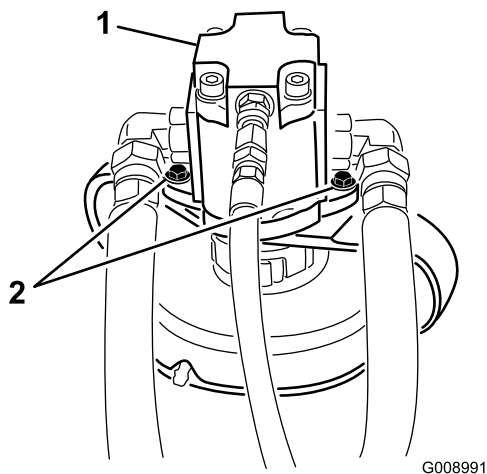

Figure 81

- |                     |                    |
|---------------------|--------------------|
| 1. Idler stop screw | 3. .10 to .16 inch |
| 2. Idler pulley     |                    |

4. Remove the bolts securing the hydraulic motor to the cutting unit (Figure 82). Lift the motor off of the cutting unit and lay it on top of the cutting unit.



**Figure 82**

G008991

- 1. Hydraulic motor
- 2. Mounting bolts

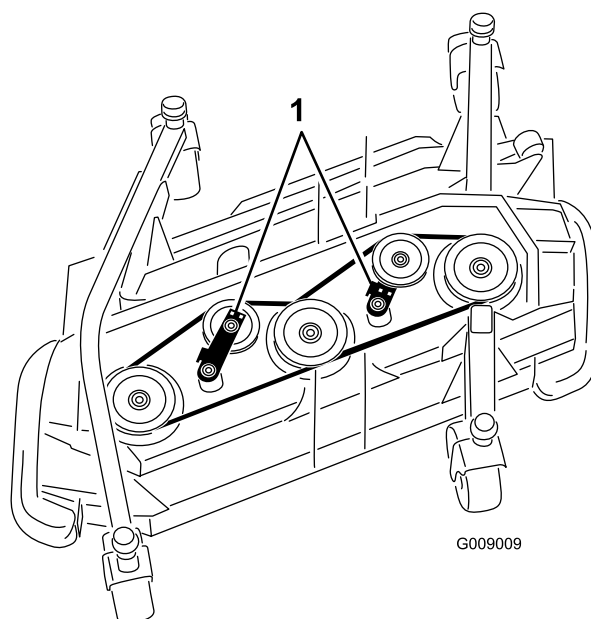
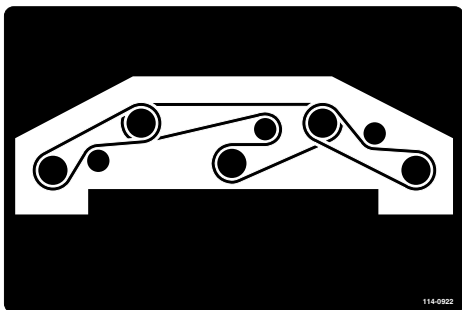

**Figure 84**

G009009

- 1. Idler pulleys

- 5. Remove the old belt from around the spindle pulleys and idler pulley.
- 6. Route the new belt around the spindle pulleys and idler pulley assembly as shown in [Figure 83](#).

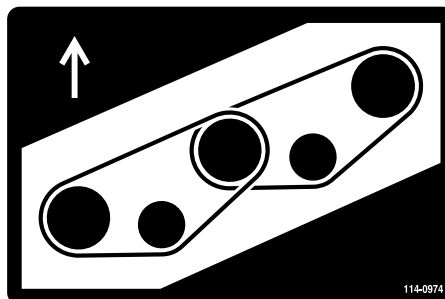

**Figure 83**

114-0922

- 7. Readjust the idler pulley stop screw and tighten the jam nuts.

- 4. Remove the old belt from around the spindle pulleys and idler pulley.
- 5. Route the new belt around the spindle pulleys and idler pulley assembly as shown in [Figure 85](#) and [Figure 86](#).



**Figure 85**

Right side deck

114-0974

## Side Cutting Decks

**Note:** To remove the lower belt, the upper belt must first be removed.

- 1. Lower the cutting unit to the shop floor. Remove the belt covers from the top of the cutting unit and set the covers aside.
- 2. Remove the bolts securing the hydraulic motor to the cutting unit ([Figure 82](#)). Lift the motor off of the cutting unit and lay it on top of the cutting unit.
- 3. Using a ratchet wrench or similar tool, move the idler pulleys ([Figure 84](#)) away from the drive belt to release the belt tension and allow the belt to be slipped off the pulleys.

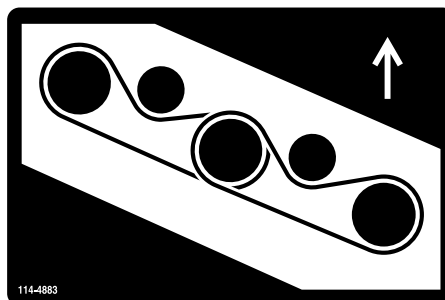

**Figure 86**

Left side deck

114-4883

# Hydraulic System Maintenance

## Checking the Hydraulic Fluid

**Service Interval:** Before each use or daily—Check the hydraulic fluid level.

The machine's reservoir is filled at the factory with approximately 19 U.S. gallons (71.9 l) of high quality hydraulic fluid. **Check the level of the hydraulic fluid before the engine is first started and daily thereafter.** The recommended replacement fluid is:

**Toro Premium All Season Hydraulic Fluid** (Available in 5 gallon pails or 55 gallon drums. See parts catalog or Toro distributor for part numbers.)

**Alternate fluids:** If the Toro fluid is not available, other fluids may be used provided they meet all the following material properties and industry specifications. We do not recommend the use of synthetic fluid. Consult with your lubricant distributor to identify a satisfactory product.

**Note:** Toro will not assume responsibility for damage caused by improper substitutions, so use only products from reputable manufacturers who will stand behind their recommendation.

### High Viscosity Index/Low Pour Point Anti-wear Hydraulic Fluid, ISO VG 46

#### Material Properties:

Viscosity, ASTM D445	St @ 40° C 44 to 48
	St @ 100° C 7.9 to 8.5
Viscosity Index ASTM D2270	140 to 160
Pour Point, ASTM D97	-34° F to -49° F
FZG, Fail stage	11 or better
Water content (new fluid)	500 ppm (maximum)

**Industry Specifications:** Vickers I-286-S (Quality Level), Vickers M-2950-S (Quality Level), Denison HF-0

**Note:** Many hydraulic fluids are almost colorless, making it difficult to spot leaks. A red dye additive for the hydraulic system oil is available in 2/3 oz (20 ml) bottles. One bottle is sufficient for 4-6 gallons (15-22 l) of hydraulic oil. Order part no. 44-2500 from your authorized Toro distributor.

**Note:** If ambient operating temperatures exceed 110° F, contact Toro for fluid recommendations.

1. Position the machine on a level surface, lower the cutting units, stop the engine, and remove the key.
2. On the right side of the machine, raise the access cover to expose the hydraulic tank cap (Figure 87).

3. Clean the area around the filler neck and cap of the hydraulic tank (Figure 87). Remove the cap from the filler neck.

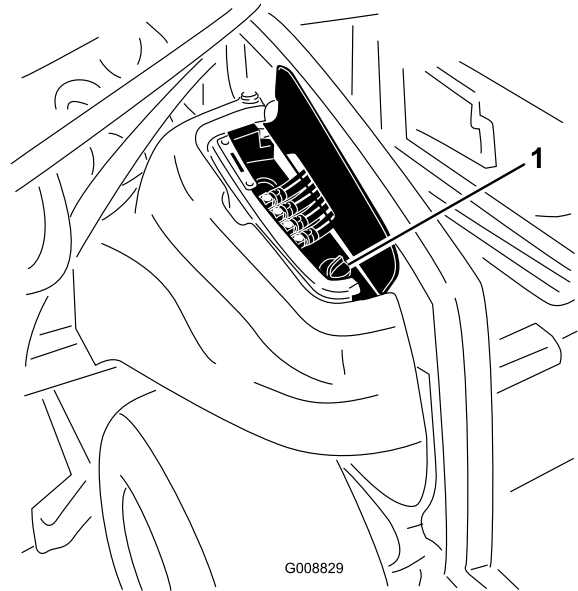

Figure 87

1. Hydraulic tank cap

4. Remove the dipstick from the filler neck and wipe it with a clean rag. Insert the dipstick into the filler neck; then remove it and check the fluid level. The fluid level should be within the safe operating range on the dipstick (Figure 88).

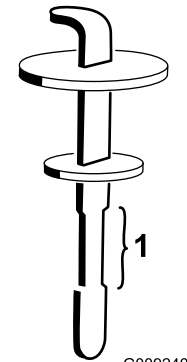

Figure 88

1. Safe operating range

5. If the level is low, add the appropriate fluid to raise the level to the upper mark.
6. Install the dipstick and cap onto the filler neck.
7. Close the cover.

# Changing the Hydraulic Fluid and Filters

**Service Interval:** Every 1,000 hours—Change the hydraulic fluid and filters.

Change the 2 hydraulic filters and the hydraulic fluid after every 1000 operating hours, in normal operating conditions. If the fluid becomes contaminated, contact your local Toro distributor because the system must be flushed. Contaminated fluid looks milky or black when compared to clean oil.

Use Toro replacement filters (Part No. 86-6110 for the left side of the machine and 75-1310 for the right side of the machine).

**Important:** Use of any other filter may void the warranty on some components.

1. Position the machine on a level surface, lower the cutting units, stop the engine, engage the parking brakes, and remove the ignition key.
2. Place a large drain pan under the hydraulic fluid tank.
3. Remove the drain plug (Figure 89) from the bottom of the tank and let the hydraulic fluid flow into the pan. Install the drain plug when the hydraulic fluid stops draining.

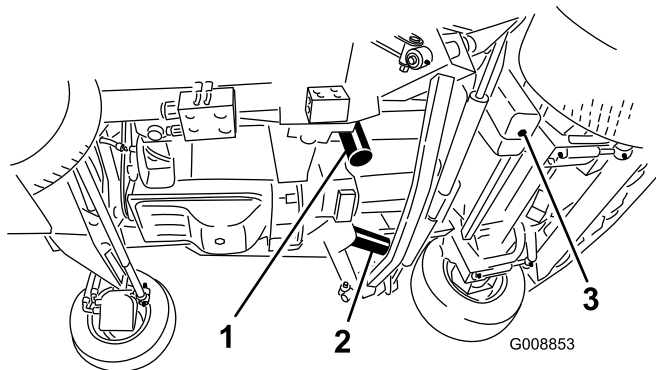

Figure 89

1. Hydraulic filter
2. Hydraulic filter
3. Hydraulic tank drain plug

4. Clean the area around the filter mounting areas. Place a drain pan under the filter and remove the filter (Figure 89).
5. Lubricate the new filter gasket and fill the filter with hydraulic fluid.
6. Ensure that the filter mounting area is clean. Screw the filters on until the gaskets contacts the mounting plates; then tighten the filter an additional 1/2 turn.
7. Fill the reservoir with hydraulic fluid; refer to Checking the Hydraulic Fluid.

**Important:** Use only the hydraulic fluids specified. Other fluids could cause system damage.

8. Install the reservoir cap. Start the engine and use all of the hydraulic controls to distribute hydraulic fluid throughout the system. Also check for leaks; then stop the engine.
9. Check the fluid level and add enough to raise level the level to the Full mark on the dipstick. **Do not overfill.**

## Checking the Hydraulic Lines and Hoses

**Service Interval:** Every 2 years—Replace moving hoses.

Inspect the hydraulic lines and hoses daily for leaks, kinked lines, loose mounting supports, wear, loose fittings, weather deterioration, and chemical deterioration. Make all necessary repairs before operating.

### ⚠ WARNING

Hydraulic fluid escaping under pressure can penetrate skin and cause injury.

- Make sure all hydraulic fluid hoses and lines are in good condition and all hydraulic connections and fittings are tight before applying pressure to the hydraulic system.
- Keep your body and hands away from pin hole leaks or nozzles that eject high pressure hydraulic fluid.
- Use cardboard or paper to find hydraulic leaks.
- Safely relieve all pressure in the hydraulic system before performing any work on the hydraulic system.
- Seek immediate medical attention if fluid is injected into skin.

## Hydraulic System Test Ports

The test ports are used to test the pressure in the hydraulic circuits. Contact your local Toro distributor or refer to the Toro Service Manual for assistance.

# Mower Maintenance

## Pivoting (Tilting) the Front Cutting Unit Upright

**Note:** Although not needed for normal maintenance procedures, the front cutting unit can be pivoted (tilted) to an upright position. Should you desire to tilt the cutting unit, proceed as follows:

1. Raise the front cutting unit slightly off of the floor, set the parking brake, and stop the engine. Remove the ignition key.
2. Remove the retainer clip and disconnect the damper assembly from the cutting unit (Figure 90).

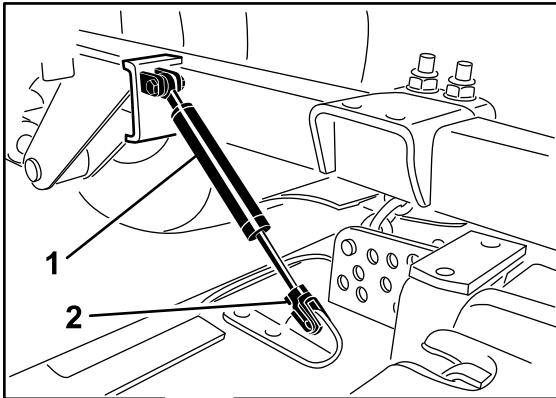

Figure 90

1. Damper assembly
2. Retainer clip

3. Remove the hairpin cotter and clevis pin securing the height-of-cut chains to the rear of the cutting unit (Figure 91).

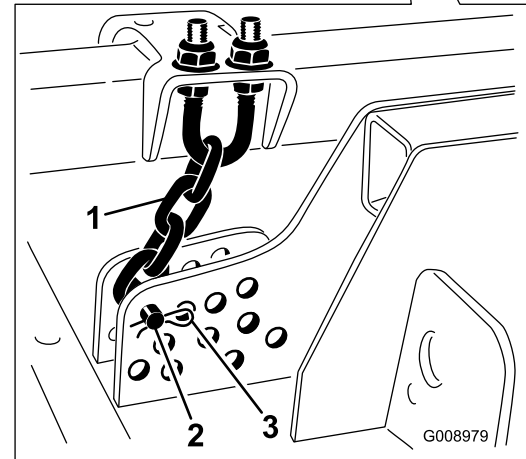
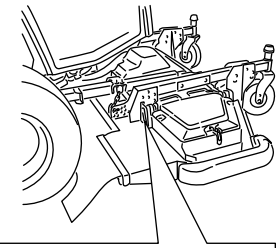

Figure 91

1. Height of cut chain
2. Clevis pin
3. Hair pin cotter

4. Start the engine, slowly raise the front cutting unit, and stop the engine. Remove the ignition key.
5. Wedge a 2 x 4 between the rear of the deck and the machine (Figure 92).

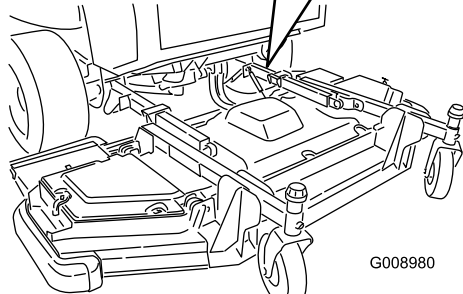

Figure 90

1. Damper assembly
2. Retainer clip

3. Remove the hairpin cotter and clevis pin securing the height-of-cut chains to the rear of the cutting unit (Figure 91).

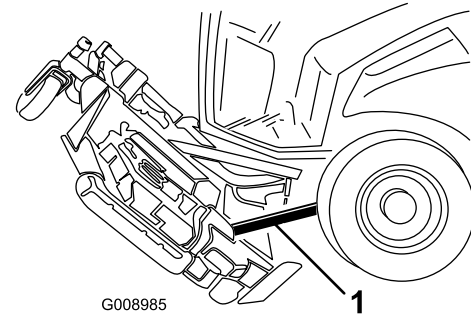

Figure 92

1. 2 x 4

## Pivoting the Front Cutting Unit Down

1. With the help of another person holding the front of the cutting unit, remove the 2 x 4.
2. Sit on the seat, start the engine, and lower the cutting unit until it is slightly off of the floor.
3. Secure the height-of-cut chains to the rear of the cutting unit.
4. Connect the damper assembly and secure it with the retainer clip.

# Adjusting the Cutting Unit Pitch

## Measuring the Cutting Unit Pitch

Cutting unit pitch is the difference in height-of-cut from the front of the blade plane to the back of the blade plane. Toro recommends a blade pitch of .300 inch (7.5 mm). That is the back of the blade plane is .300 inch (7.5 mm) higher than the front.

1. Position the machine on a level surface on the shop floor.
2. Set the cutting unit to the desired height-of-cut.
3. Make sure the winglets are level to the front deck and the front deck is level side to side.

## Adjusting the Front Cutting Unit

1. Rotate the 2 outer front blades and the winglet blades so that they point straight forward (Figure 93).

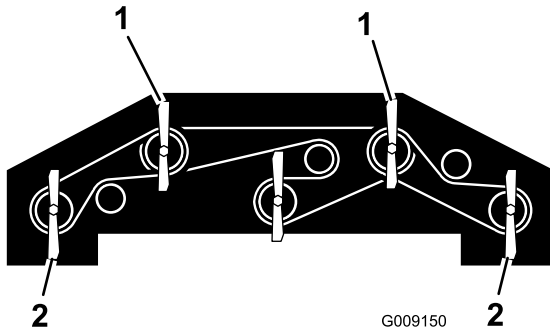

Figure 93

- |   |  |
|---|--|
| 1. Use one of these blades for measuring the front blade height | 2. Use one of these blades for measuring the rear blade height |
|---|--|

2. Using a short ruler, measure from the floor to the front tip of the front blade and record this dimension.
3. Measure from the floor to the back tip of the winglet blade and record this dimension.
4. Subtract the front dimension from the rear dimension to calculate the blade pitch.
5. Loosen the jam nuts on the top or bottom of the height-of-cut chain U-bolt (Figure 94).

**Note:** Loosen or tighten the height of cut chain nuts equally so the deck remains level side to side.

6. Adjust the other set of nuts to raise or lower the rear of the cutting unit and attain the correct cutting unit pitch.
7. Tighten the jam nuts.

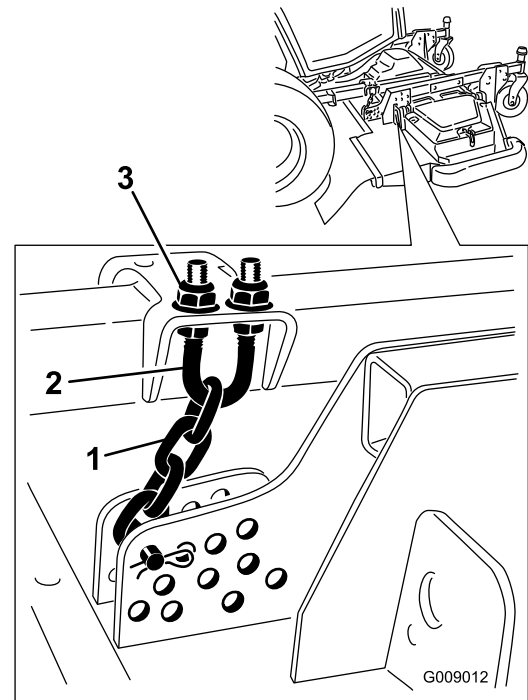

Figure 94

- |                        |            |
|------------------------|------------|
| 1. Height-of-cut chain | 3. Nut (2) |
| 2. U-bolt              |            |

## Adjusting the Side Cutting Units

1. Remove the tensioning cap from the castor spindle shaft and slide the spindle out of the castor arm (Figure 95). Reposition the shims, as required, to raise or lower the castor wheel until the cutting unit has the correct pitch.
2. Install the tensioning cap.

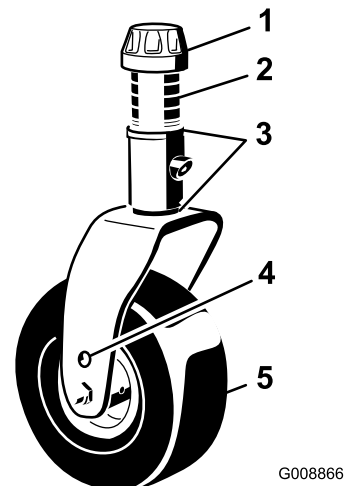

Figure 95

- |                   |                           |
|-------------------|---------------------------|
| 1. Tensioning cap | 4. Top axle mounting hole |
| 2. Spacers        | 5. Castor wheel           |
| 3. Shims          |                           |

# Servicing the Castor Arm Bushings

The castor arms have bushings pressed into the top and bottom of the tube and after many hours of operation, the bushings will wear. To check the bushings, move the castor fork back and forth and from side to side. If the castor spindle is loose inside the bushings, the bushings are worn and must be replaced.

1. Raise the cutting unit so that the wheels are off of the floor. Block the cutting unit so that it cannot accidentally fall.
2. Remove the tensioning cap, spacer(s), and thrust washer from the top of the castor spindle.

**Note:** Record the position of the washers and spacers before removal so the deck pitch does not have to be readjusted.

3. Pull the castor spindle out of the mounting tube. Allow the thrust washer and spacer(s) to remain on the bottom of the spindle.
4. Insert a pin punch into the top or bottom of the mounting tube and drive the bushing out of the tube (Figure 96). Also drive the other bushing out of the tube. Clean the inside of the tubes to remove dirt.

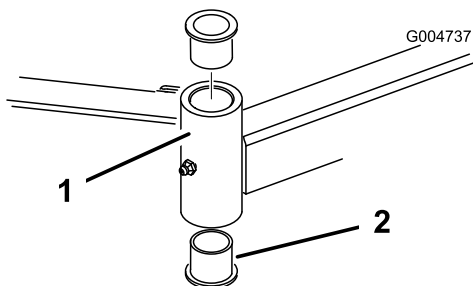

Figure 96

1. Castor arm tube
2. Bushings

5. Apply grease to the inside and outside of the new bushings. Using a hammer and flat plate, drive the bushings into the mounting tube.
6. Inspect the castor spindle for wear and replace it if it is damaged.
7. Push the castor spindle through the bushings and mounting tube. Slide the thrust washer and spacer(s) onto the spindle. Install the tensioning cap on the castor spindle to retain all parts in place.

# Servicing the Castor Wheels and Bearings

**Service Interval:** Every 500 hours—Inspect the cutting unit castor wheel assemblies.

1. Remove the locknut from the bolt holding the castor wheel assembly between the castor fork (Figure 97) or

the castor pivot arm. Grasp the castor wheel and slide the bolt out of the fork or pivot arm.

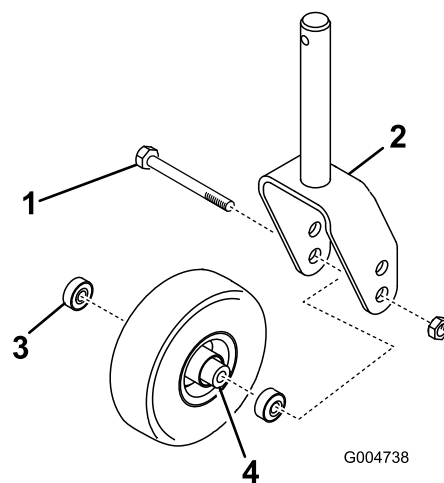

Figure 97

1. Castor wheel
2. Castor fork
3. Bearing
4. Bearing spacer

2. Remove the bearing from the wheel hub and allow the bearing spacer to fall out (Figure 97). Remove the bearing from the opposite side of the wheel hub.
3. Check the bearings, spacer, and inside of the wheel hub for wear. Replace any damaged parts.
4. To assemble the castor wheel, push the bearing into the wheel hub. When installing the bearings, press on the outer race of the bearing.
5. Slide the bearing spacer into the wheel hub. Push the other bearing into the open end of the wheel hub to captivate the bearing spacer inside the wheel hub.
6. Install the castor wheel assembly between the castor fork and secure it in place with the bolt and locknut.

# Blade Maintenance

## Checking for a Bent Blade

After striking a foreign object, inspect the machine for damage and make repairs before restarting and operating the equipment. Torque all the spindle pulley nuts to 130 to 150 ft-lb (176 to 203 N·m).

1. Position the machine on a level surface. Raise the cutting unit, engage the parking brake, put the traction pedal in neutral, make sure the PTO switch is in the Off position, stop the engine, and remove the ignition key. Block the cutting unit to prevent it from accidentally falling.
2. Rotate the blade until the ends face forward and backward (Figure 98). Measure from the inside of the cutting unit to the cutting edge at the front of the blade. Record this dimension.

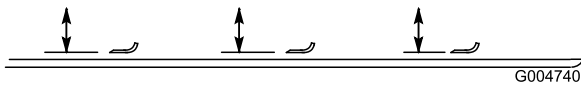

Figure 98

3. Rotate the opposite end of the blade forward. Measure between the cutting unit and cutting edge of the blade at the same position as in step 2. The difference between the dimensions obtained in steps 2 and 3 must not exceed 1/8 inch (3 mm). If the dimension exceeds 1/8 inch (3 mm), the blade is bent and must be replaced; refer to Removing and Installing the Cutter Blade.

## Removing and Installing the Cutter Blade(s)

The blade must be replaced if a solid object is hit, the blade is out of balance, or if the blade is bent. Always use genuine Toro replacement blades to be sure of safety and optimum performance. Never use replacement blades made by other manufacturers because they could be dangerous.

1. Raise the cutting unit to the highest position, engage the parking brake, stop the engine, and remove the ignition key. Block the cutting unit to prevent it from accidentally falling.
2. Grasp the end of the blade using a rag or thickly padded glove. Remove the blade bolt, anti-scalp cup, and blade from the spindle shaft (Figure 99).
3. Install the blade, anti-scalp cup, and blade bolt. Tighten the blade bolt to 85 to 110 ft-lb (115 to 149 N·m).

**Important:** The curved part of the blade must be pointing toward the inside of the cutting unit to ensure proper cutting.

**Note:** After striking a foreign object, torque all the spindle pulley nuts to 130 to 150 ft-lb (176 to 203 N·m) and the blade bolts to 85 to 110 ft-lb (115 to 149 N·m).

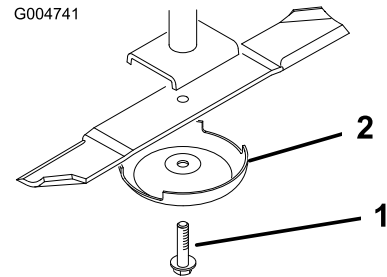

Figure 99

1. Blade bolt
2. Anti-scalp cup

## Inspecting and Sharpening the Cutter Blade(s)

**Service Interval:** After the first 10 hours

Every 50 hours

Before each use or daily

### **▲ DANGER**

**A worn or damaged blade can break, and a piece of the blade could be thrown into the operator's or bystander's area, resulting in serious personal injury or death. Trying to repair a damaged blade may result in discontinued safety certification of the product.**

- Inspect the blade periodically for wear or damage.
- Never try to straighten a blade that is bent or weld a broken or cracked blade
- Replace a worn or damaged blade.

Two areas must be considered when checking and servicing the cutter blade—the sail and the cutting edge. Both cutting edges and the sail, which is the turned up portion opposite the cutting edge, contribute to a good quality-of-cut. The sail is important because it lifts the grass up straight, thereby producing an even cut. However, the sail will gradually wear down during operation, and this condition is normal. As the sail wears down, the quality-of-cut will degrade somewhat, although the cutting edges are sharp. The cutting edge of the blade must be sharp so that the grass is cut rather than torn. A dull cutting edge is evident when the tips of the grass appear brown and shredded. Sharpen the cutting edges to correct this condition.

1. Position the machine on a level surface. Raise the cutting unit, engage the parking brake, put the traction

pedal in neutral, make sure the PTO switch is in the Off position, stop the engine, and remove the ignition key.

- Examine the cutting ends of the blade carefully, especially where the flat and curved parts of the blade meet (Figure 100). Since sand and abrasive material can wear away the metal that connects the flat and curved parts of the blade, check the blade before using the mower. If wear is noticed (Figure 100), replace the blade.

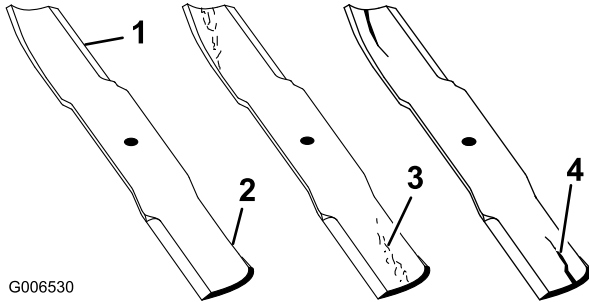

Figure 100

- |                 |                      |
|-----------------|----------------------|
| 1. Cutting Edge | 3. Wear/slot Forming |
| 2. Curved Area  | 4. Crack             |

- Examine the cutting edges of all of the blades. Sharpen the cutting edges if they are dull or nicked. Sharpen only the top of the cutting edge and maintain the original cutting angle to make sure of sharpness (Figure 101). The blade will remain balanced if the same amount of metal is removed from both cutting edges.

### **⚠ DANGER**

If the blade is allowed to wear, a slot will form between the sail and flat part of the blade (Figure 101). Eventually a piece of the blade may break off and be thrown from under the housing, possibly resulting in serious injury to you or bystanders.

- Inspect the blade periodically for wear or damage.
- Never try to straighten a blade that is bent or weld a broken or cracked blade.
- Replace a worn or damaged blade.

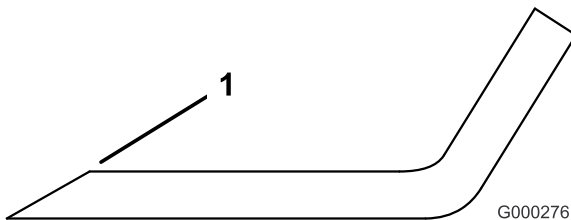

Figure 101

- Sharpen at original angle

**Note:** Remove the blades and sharpen them on a grinder. After sharpening the cutting edges, install the blade with the anti-scalp cup and blade bolt; refer to Removing and Installing the Cutter Blade(s).

## Correcting the Cutting Unit Mismatch

If there is mismatch between the blades, on a single cutting unit, the grass will appear streaked when it is cut. This problem can be corrected by making sure that the blades are straight.

- Using a 3 foot (1 meter) long carpenters level, find a level surface on the shop floor.
- Raise the height-of-cut to the highest position; refer to Adjusting the Height-Of-Cut.
- Lower the cutting unit onto the flat surface. Remove the covers from the top of the cutting unit.
- Rotate the blades until the ends face forward and backward. Measure from the floor to the front tip of the cutting edge. Record this dimension. Then rotate the same blade so that the opposite end is forward, and measure again. The difference between the dimensions must not exceed 1/8 inch (3 mm). If the dimension exceeds 1/8 inch (3 mm), replace the blade because it is bent. Make sure to measure all of the blades.
- Check that deck is level side to side and adjust as required.
- Install the belt covers.

# Miscellaneous Maintenance

## Servicing the Spark Arrestor Muffler

**Service Interval:** Every 250 hours—Service the spark arrestor.

Every 250 hours operation, clear the muffler of carbon buildup.

1. Remove the pipe plug from the clean-out port at the lower side of the muffler.

### ⚠ CAUTION

The muffler may be hot and could cause injury.

Be careful while working around the muffler.

2. Start the engine. Plug the normal muffler exit with a block of wood or metal plate so that the exhaust flow will be forced out of the clean-out port. Continue to block the exit until carbon deposits cease coming out of the port.

### ⚠ CAUTION

Do not stand in line with the clean-out port.

Always wear safety glasses.

3. Stop the engine and replace the pipe plug.

## Cleaning the Cab Air Filters

**Service Interval:** Every 250 hours—Clean the cab air filters. (Clean more frequently in extremely dusty or dirty conditions and replace them if they are torn or excessively dirty.)

1. Remove the thumb screws and grates from over both the in-cab and rear cab air filters (Figure 102).

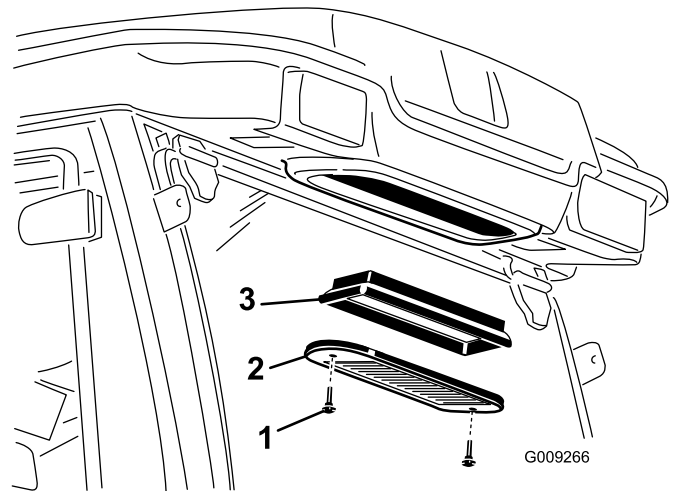
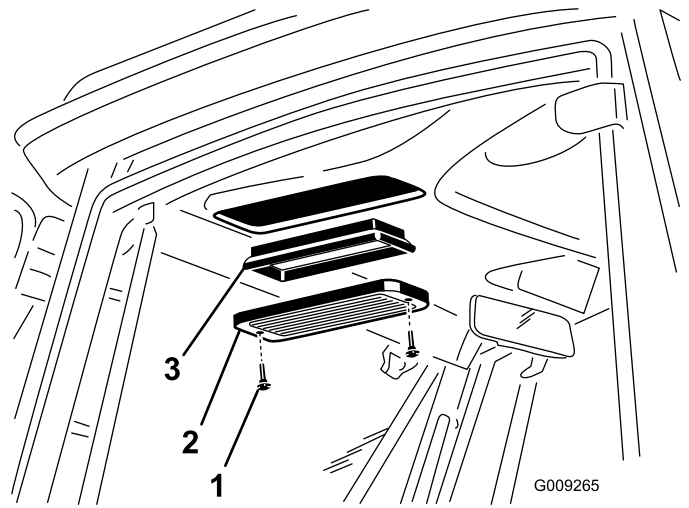

Figure 102

1. Thumb screw
2. Grate
3. Air filter

2. Clean the filters by blowing clean, oil free, compressed air through them.

**Important:** If either filter has a hole, tear, or other damage, replace it.

3. Install the filters and grate, securing them with the thumb screws.

## Cleaning the Air Conditioning Coil

**Service Interval:** Every 250 hours—Clean the air conditioning coil. (Clean more frequently in extremely dusty or dirty conditions)

1. Stop the engine and remove the key.
2. Remove the (4) screws securing the fan and the condenser cover to the fan mount (Figure 103).
3. Carefully lift the fan out of the condenser cover.

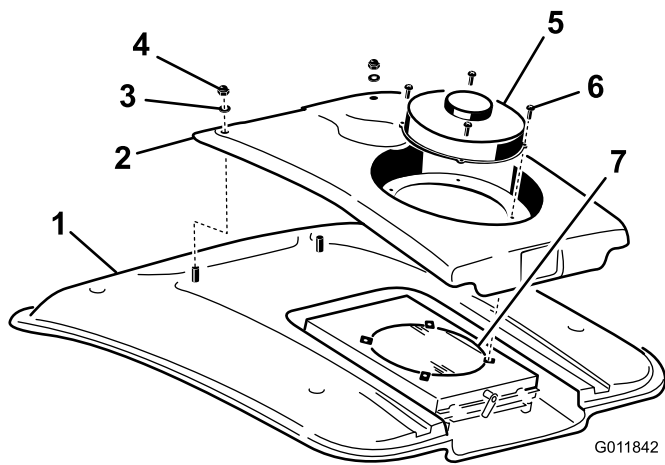

**Figure 103**

- |                    |                               |
|--------------------|-------------------------------|
| 1. Cabin roof      | 5. Fan                        |
| 2. Condenser cover | 6. Screw                      |
| 3. Washer          | 7. Air conditioning condenser |
| 4. Nut             |                               |

4. Remove the two nuts and washers securing the front of the condenser cover to the cab roof (Figure 103).
5. Unplug the fan wire connectors located between the cover and roof.
6. Remove the fan and the cover.
7. Remove and clean the A/C Condenser Screen. Refer to Cleaning the A/C Condenser Screen.
8. Clean the air conditioning condenser thoroughly with compressed air (Figure 103).
9. Replace the A/C Condenser Screen.
10. Replace the condenser cover and fan. Make sure to connect the fan wires before securing the condenser cover.

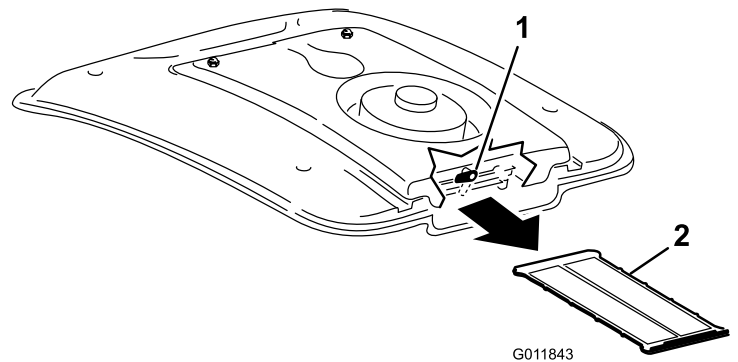

**Figure 104**

- |          |               |
|----------|---------------|
| 1. Latch | 2. A/C screen |
|----------|---------------|
3. Slide the A/C screen out from under the air conditioning coil (Figure 104).
  4. Clean the screen thoroughly with compressed air (Figure 104).
  5. Slide the screen into the channels under the air conditioning coil and rotate the latch downward.

## Cleaning the A/C Condenser Screen

**Service Interval:** Every 50 hours—Clean the air conditioning screen. (Clean more frequently in extremely dusty or dirty conditions)

1. Stop the engine and remove the key.
2. On the rear of the fan mount, rotate the latch to the side (Figure 104).

# Storage

## Preparing for Seasonal Storage

### Traction Unit

1. Thoroughly clean the traction unit, cutting units, and the engine.

**Important: Do not use high pressure water near Info Center**

2. Check the tire pressure; refer to Checking the Tire Pressure procedure in Operation.
3. Check all fasteners for looseness; tighten as necessary.
4. Grease or oil all grease fittings and pivot points. Wipe up any excess lubricant.
5. Lightly sand and use touch-up paint on painted areas that are scratched, chipped, or rusted. Repair any dents in the metal body.
6. Service the battery and cables as follows:
  - A. Remove the battery terminals from the battery posts.
  - B. Clean the battery, terminals, and posts with a wire brush and baking soda solution.
  - C. Coat the cable terminals and battery posts with Grafo 112X skin-over grease (Toro Part No. 505-47) or petroleum jelly to prevent corrosion.
  - D. Slowly recharge the battery every 60 days for 24 hours to prevent lead sulfation of the battery.

### Engine

1. Drain the engine oil from the oil pan and install the drain plug.
2. Remove and discard the oil filter. Install a new oil filter.
3. Refill the oil pan with 8.5 qt (8.04 l) of SAE 15W-40 CH-4, CI-4 or higher motor oil.
4. Start the engine and run it at idle speed for approximately two minutes.
5. Stop the engine.
6. Flush the fuel tank with fresh, clean diesel fuel.
7. Secure all of the fuel system fittings.
8. Thoroughly clean and service the air cleaner assembly.
9. Seal the air cleaner inlet and the exhaust outlet with weatherproof tape.
10. Check the anti freeze protection and add a 50/50 solution of water and ethylene glycol anti-freeze as needed for the expected minimum temperature in your area.



**Notes:**

**Notes:**

# Notes:



# The Toro Total Coverage Guarantee

## A Limited Warranty

### Conditions and Products Covered

The Toro Company and its affiliate, Toro Warranty Company, pursuant to an agreement between them, jointly warrant your Toro Commercial product ("Product") to be free from defects in materials or workmanship for two years or 1500 operational hours\*, whichever occurs first. This warranty is applicable to all products with the exception of Aerators (refer to separate warranty statements for these products). Where a warrantable condition exists, we will repair the Product at no cost to you including diagnostics, labor, parts, and transportation. This warranty begins on the date the Product is delivered to the original retail purchaser.

\* Product equipped with an hour meter.

### Instructions for Obtaining Warranty Service

You are responsible for notifying the Commercial Products Distributor or Authorized Commercial Products Dealer from whom you purchased the Product as soon as you believe a warrantable condition exists. If you need help locating a Commercial Products Distributor or Authorized Dealer, or if you have questions regarding your warranty rights or responsibilities, you may contact us at:

Toro Commercial Products Service Department  
Toro Warranty Company  
8111 Lyndale Avenue South  
Bloomington, MN 55420-1196  
952-888-8801 or 800-952-2740  
E-mail: commercial.warranty@toro.com

### Owner Responsibilities

As the Product owner, you are responsible for required maintenance and adjustments stated in your *Operator's Manual*. Failure to perform required maintenance and adjustments can be grounds for disallowing a warranty claim.

### Items and Conditions Not Covered

Not all product failures or malfunctions that occur during the warranty period are defects in materials or workmanship. This warranty does not cover the following:

- Product failures which result from the use of non-Toro replacement parts, or from installation and use of add-on, or modified non-Toro branded accessories and products. A separate warranty may be provided by the manufacturer of these items.
- Product failures which result from failure to perform recommended maintenance and/or adjustments. Failure to properly maintain your Toro product per the Recommended Maintenance listed in the *Operator's Manual* can result in claims for warranty being denied.
- Product failures which result from operating the Product in an abusive, negligent, or reckless manner.
- Parts subject to consumption through use unless found to be defective. Examples of parts which are consumed, or used up, during normal Product operation include, but are not limited to, brake pads and linings, clutch linings, blades, reels, rollers and bearings (sealed or greasable), bed knives, spark plugs, castor wheels and bearings, tires, filters, belts, and certain sprayer components such as diaphragms, nozzles, and check valves, etc.
- Failures caused by outside influence. Conditions considered to be outside influence include, but are not limited to, weather, storage practices, contamination, use of unapproved fuels, coolants, lubricants, additives, fertilizers, water, or chemicals, etc.
- Failure or performance issues due to the use of fuels (e.g. gasoline, diesel, or biodiesel) that do not conform to their respective industry standards.

### Countries Other than the United States or Canada

Customers who have purchased Toro products exported from the United States or Canada should contact their Toro Distributor (Dealer) to obtain guarantee policies for your country, province, or state. If for any reason you are dissatisfied with your Distributor's service or have difficulty obtaining guarantee information, contact the Toro importer.

- Normal noise, vibration, wear and tear, and deterioration.
- Normal "wear and tear" includes, but is not limited to, damage to seats due to wear or abrasion, worn painted surfaces, scratched decals or windows, etc.

### Parts

Parts scheduled for replacement as required maintenance are warranted for the period of time up to the scheduled replacement time for that part. Parts replaced under this warranty are covered for the duration of the original product warranty and become the property of Toro. Toro will make the final decision whether to repair any existing part or assembly or replace it. Toro may use remanufactured parts for warranty repairs.

### Deep Cycle and Lithium-Ion Battery Warranty:

Deep cycle and Lithium-Ion batteries have a specified total number of kilowatt-hours they can deliver during their lifetime. Operating, recharging, and maintenance techniques can extend or reduce total battery life. As the batteries in this product are consumed, the amount of useful work between charging intervals will slowly decrease until the battery is completely worn out. Replacement of worn out batteries, due to normal consumption, is the responsibility of the product owner. Battery replacement may be required during the normal product warranty period at owner's expense. Note: (Lithium-Ion battery only): A Lithium-Ion battery has a part only prorated warranty beginning year 3 through year 5 based on the time in service and kilowatt hours used. Refer to the *Operator's Manual* for additional information.

### Maintenance is at Owner's Expense

Engine tune-up, lubrication, cleaning and polishing, replacement of filters, coolant, and completing recommended maintenance are some of the normal services Toro products require that are at the owner's expense.

### General Conditions

Repair by an Authorized Toro Distributor or Dealer is your sole remedy under this warranty.

**Neither The Toro Company nor Toro Warranty Company is liable for indirect, incidental or consequential damages in connection with the use of the Toro Products covered by this warranty, including any cost or expense of providing substitute equipment or service during reasonable periods of malfunction or non-use pending completion of repairs under this warranty. Except for the Emissions warranty referenced below, if applicable, there is no other express warranty. All implied warranties of merchantability and fitness for use are limited to the duration of this express warranty.**

Some states do not allow exclusions of incidental or consequential damages, or limitations on how long an implied warranty lasts, so the above exclusions and limitations may not apply to you. This warranty gives you specific legal rights, and you may also have other rights which vary from state to state.

### Note regarding engine warranty:

The Emissions Control System on your Product may be covered by a separate warranty meeting requirements established by the U.S. Environmental Protection Agency (EPA) and/or the California Air Resources Board (CARB). The hour limitations set forth above do not apply to the Emissions Control System Warranty. Refer to the Engine Emission Control Warranty Statement supplied with your product or contained in the engine manufacturer's documentation for details