



**12-38 HXL**

# **Lawn Tractor**

**Model No. 71203 - 3900001 & Up**

---

## **Operator's Manual**

**IMPORTANT:** Read this manual carefully. It contains information about your safety and the safety of others. Also become familiar with the controls and their proper use before you operate the product.

# Introduction

Thank you for purchasing a Toro product.

All of us at Toro want you to be completely satisfied with your new product, so feel free to contact your local Authorized Service Dealer for help with service, genuine Toro replacement parts, or other information you may require.

Whenever you contact your Authorized Service Dealer or the factory, always know the model and serial numbers of your product. These numbers will help the Service Dealer or Service Representative provide exact information about your specific product. You will find the model and serial number plate located in a unique place on the product as shown below.

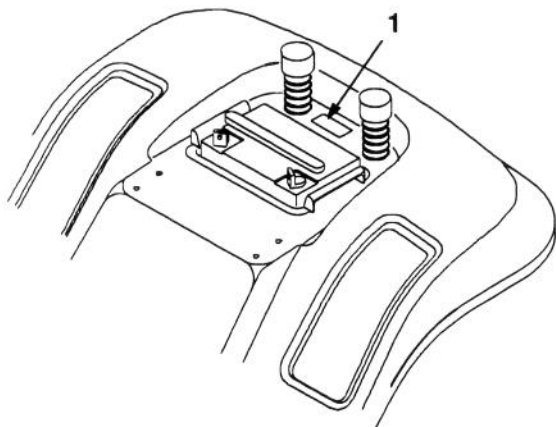

1. Model and Serial Number Plate  
(under the seat)

For your convenience, write the product model and serial numbers in the space below.

<b>Model No.</b> _____
<b>Serial No.</b> _____

Read this manual carefully to learn how to operate and maintain your product correctly. Reading this manual will help you and others avoid personal injury and damage to the product. Although Toro designs, produces and markets safe, state-of-the-art products, you are responsible for using the product properly and safely. You are also responsible for training persons who you allow to use the product about safe operation.

The Toro warning system in this manual identifies potential hazards and has special safety messages that help you and others avoid personal injury, even death. DANGER, WARNING and CAUTION are signal words used to identify the level of hazard. However, regardless of the hazard, be extremely careful.

**DANGER** signals an extreme hazard that will cause serious injury or death if the recommended precautions are not followed.

**WARNING** signals a hazard that may cause serious injury or death if the recommended precautions are not followed.

**CAUTION** signals a hazard that may cause minor or moderate injury if the recommended precautions are not followed.

Two other words are also used to highlight information. "Important" calls attention to special mechanical information and "Note" emphasizes general information worthy of special attention.

The left and right side of the machine is determined by sitting on the seat in the normal operator's position.

# Contents

	<b>Page</b>		<b>Page</b>
Safety .....	2	Maintenance .....	17
Safe Operating Practices .....	2	Service Interval Chart .....	17
Slope Chart .....	5	Greasing and Lubrication .....	18
ISO Symbols .....	7	Tire Pressure .....	19
Gasoline and Oil .....	8	Brake .....	19
Recommended Gasoline .....	8	Wiring Diagram .....	20
Stabilizer/Conditioner .....	8	Fuse .....	21
Filling the Fuel Tank .....	8	Headlights .....	21
Check Engine Oil Level .....	8	Battery .....	22
Operation .....	9	Spark Plug .....	24
Think Safety First .....	9	Fuel Tank .....	25
Controls .....	9	Fuel Filter .....	25
Parking Brake .....	9	Throttle and Choke Control .....	26
Positioning the Seat .....	10	Carburetor .....	27
Positioning the Tilt Steering Wheel .....	10	Air Cleaner .....	28
Headlights .....	10	Engine Oil .....	30
Using the Blade Control (PTO) .....	11	Cutting Blade .....	32
Setting the Height-of-Cut .....	11	Removing the Mower .....	34
Starting and Stopping the Engine .....	12	Installing the Mower .....	36
The Safety System .....	13	Blade Drive Belt .....	38
Pushing the Machine by Hand .....	13	Side-to-Side Mower Leveling .....	39
Driving Forward or Backward .....	14	Front-to-Rear Blade Slope .....	40
Stopping the Machine .....	14	Storage .....	42
Side Discharge or Mulch Grass .....	15	Troubleshooting .....	43
Installing the Discharge Cover .....	15		
Tips for Mowing Grass .....	16		

# Safety

This machine meets or exceeds the B71.1-1990 specifications of the American National Standards Institute, in effect at the time of production. However, improper use or maintenance by the operator or owner can result in injury. To reduce the potential for injury, comply with these safety instructions and always pay attention to the safety alert  symbol, which means CAUTION, WARNING, or DANGER—“personal safety instruction.” Failure to comply with the instruction may result in personal injury or death.

## Safe Operating Practices

This product is capable of amputating hands and feet and throwing objects. Always follow all safety instructions to avoid serious injury or death.

### WARNING

#### POTENTIAL HAZARD

- Engine exhaust contains carbon monoxide, which is an odorless, deadly poison.

#### WHAT CAN HAPPEN

- Carbon monoxide can kill you and is also known to the State of California to cause birth defects.

#### HOW TO AVOID THE HAZARD

- Do not run engine indoors or in an enclosed area.

## General Operation

1. Read, understand, and follow all instructions in the operator’s manual and on the machine before starting.
2. Allow only responsible adults who are familiar with the instructions to operate the machine.
3. Clear the area of objects such as rocks, toys, wire, etc., which could be picked up and thrown by the blade.
4. Be sure the area is clear of other people before mowing. Stop the machine if anyone enters the area.
5. Never carry passengers.
6. Do not mow in reverse unless absolutely necessary. Always look down and behind before and while backing.
7. Be aware of the mower discharge direction and do not point it at anyone. Do not operate the mower without either the entire grass catcher or the guard in place.
8. Slow down before turning. Sharp turns on any terrain may cause loss of control.
9. Never leave a running machine unattended. Always turn off blades, set parking brake, stop engine, and remove key before dismounting.
10. Turn off blades when not mowing.
11. Keep hands, feet, hair and loose clothing away from attachment discharge area, underside of mower and any moving parts while engine is running.
12. Stop the engine before removing the grass catcher or unclogging the chute.

13. Mow only in daylight or good artificial light.
14. Do not operate the machine while under the influence of alcohol or drugs.
15. Watch for traffic when operating near or crossing roadways.
16. Use extra care when loading or unloading the machine into a trailer or truck.
17. Do not touch equipment or attachment parts which may be hot from operation. Allow to cool before attempting to maintain, adjust or service.

### Slope Operation

Slopes are a major factor related to loss-of-control and tip-over accidents, which can result in severe injury or death. All slopes require extra caution. If you cannot back up the slope or if you feel uneasy on it, do not mow it.

#### DO

- Mow up and down slopes greater than 5°, not across.
- Mow downhill only on slopes above 10°, never mow uphill. If a steep slope must be ascended, back up the hill, and drive forward down the hill, keeping the machine in gear.
- Remove obstacles such as rocks, tree limbs, etc. from the mowing area. Watch for holes, ruts or bumps, as uneven terrain could overturn the machine. Tall grass can hide obstacles.
- Use slow speed. Choose a low gear so that you will not have to stop or shift while on the slope.
- Follow the manufacturer's recommendations for wheel weight or counterweights to improve stability.
- Use extra care with grass catchers or other attachments. These can change the stability of the machine.

- Keep all movement on slopes slow and gradual. Do not make sudden changes in speed or direction.
- Avoid starting or stopping on a slope. If tires lose traction, disengage the blades and proceed slowly straight down the slope.

#### DO NOT

- Do not operate machine on hillsides or slopes exceeding 15°.
- Avoid turning on slopes. If you must turn, turn slowly and gradually downhill, if possible.
- Do not mow near drop-offs, ditches, or embankments. The machine could suddenly turn over if a wheel goes over the edge of a cliff or ditch, or if an edge caves in.
- Do not mow on wet grass. Reduced traction could cause sliding.
- Do not try to stabilize the machine by putting your foot on the ground.
- Do not use a grass catcher on steep slopes. Heavy grass bags could cause loss of control or overturn the machine.

## Children

Tragic accidents can occur if the operator is not alert to the presence of children. Children are often attracted to the machine and the mowing activity. Never assume that children will remain where you last saw them. The following requirements must be followed to prevent injury to children.

1. Keep children out of the mowing area and under the watchful care of another responsible adult.
2. Be alert and turn the machine off if children enter the area.
3. Before and while backing, look behind and down for small children.
4. Never carry children. They may fall off and be seriously injured or interfere with safe machine operation.
5. Never allow children to operate the machine.
6. Use extra care when approaching blind corners, shrubs, trees, the end of a fence or other objects that may obscure vision.
4. Keep nuts and bolts tight, especially the blade attachment bolts. Keep equipment in good condition.
5. Never tamper with safety devices. Check safety systems for proper operation before each use.
6. Keep the machine free of grass, leaves, or other debris build-up. Clean up oil or fuel spillage. Allow the machine to cool before storing.
7. Stop and inspect the equipment if you strike an object. Repair, if necessary, before restarting.
8. Grass catcher components are subject to wear, damage and deterioration, which could expose moving parts or allow objects to be thrown. Frequently check components and replace with manufacturer's recommended parts, when necessary.
9. Mower blades are sharp and can cut. Wrap the blade(s) or wear gloves, and use extra caution when servicing them.

## Service

1. Stop the engine and disconnect spark plug wire(s) before performing any service, repairs, maintenance or adjustments.
2. Use extra care when handling gasoline and other fuels. They are flammable and vapors are explosive.
  - A. Use only an approved container.
  - B. Never remove the gas cap or add fuel when the engine is running. Allow the engine to cool before refueling. Do not smoke.
  - C. Never refuel the machine indoors.
  - D. Never store the machine or fuel container inside where there is an open flame, such as near a water heater or furnace.
3. Never run a machine inside a closed area.
10. Use only genuine Toro replacement parts to ensure that original standards are maintained.
11. Check brake operation frequently. Adjust and service as required.
12. Battery acid is poisonous and can cause burns. Avoid contact with skin, eyes and clothing. Protect your face, eyes and clothing when working with a battery.
13. Battery gases can explode. Keep cigarettes, sparks and flames away from battery.



# Slope Chart

Read all safety instructions on pages 2-4.

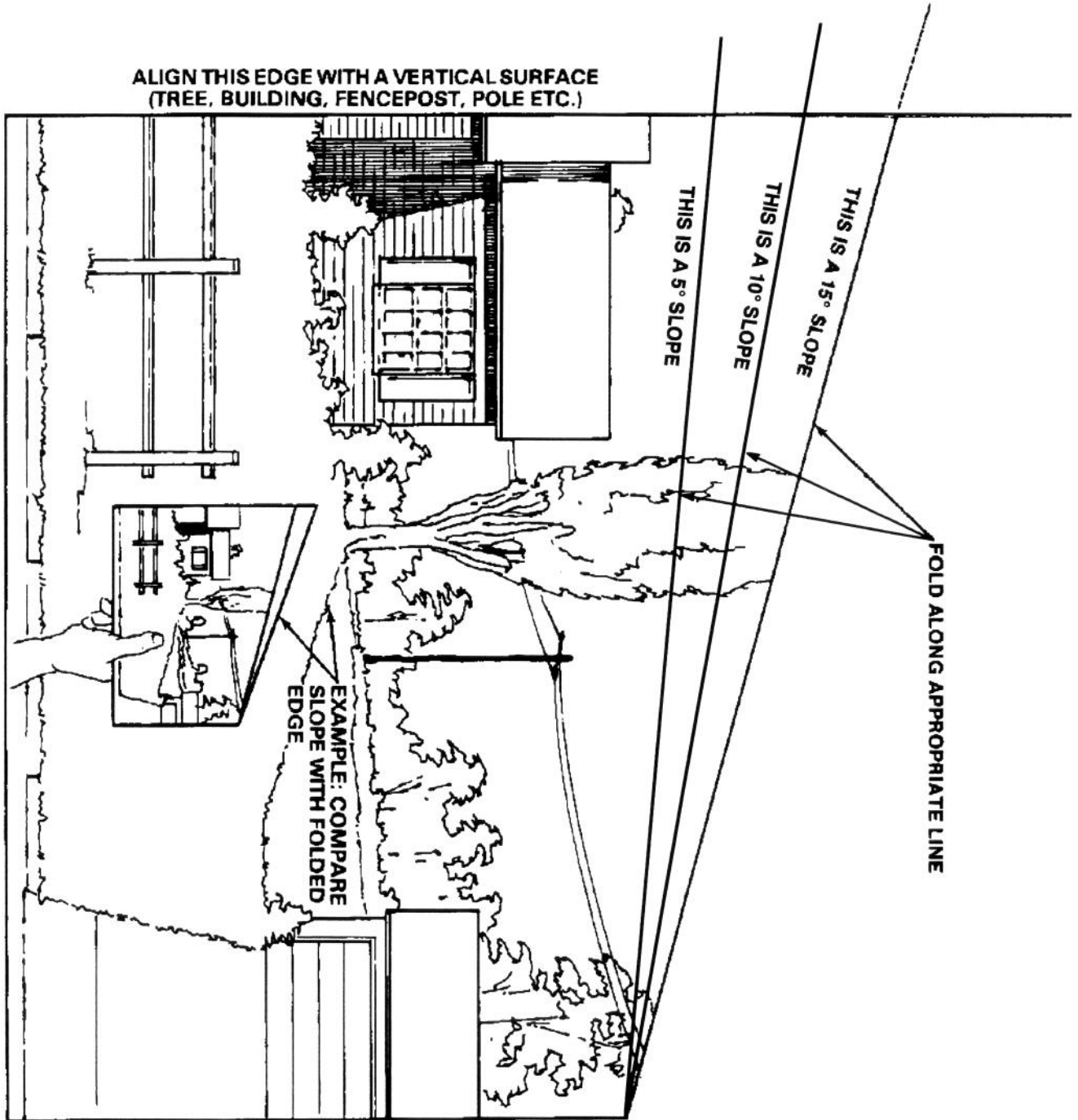



# ISO Symbols

Start switch 

Engine Stop 

Engine Run 

Engine Start 

Headlights  
— Main Beam 

On 

Off 

PTO 

Engage 

Disengage 

Parking Brake 

Choke 

Fast 

Slow 

Continuously variable  
— Linear 

# Gasoline and Oil

## Recommended Gasoline

Use UNLEADED Regular Gasoline suitable for automotive use (85 pump octane minimum). Leaded regular gasoline may be used if unleaded regular is not available.

**IMPORTANT: Never use methanol, gasoline containing methanol, or gasohol containing more than 10% ethanol because the fuel system could be damaged. Do not mix oil with gasoline.**

### DANGER

#### POTENTIAL HAZARD

- In certain conditions gasoline is extremely flammable and highly explosive.

#### WHAT CAN HAPPEN

- A fire or explosion from gasoline can burn you, others, and cause property damage.

#### HOW TO AVOID THE HAZARD

- Use a funnel and fill the fuel tank outdoors, in an open area, when the engine is cold. Wipe up any gasoline that spills.
- Do not fill the fuel tank completely full. Add gasoline to the fuel tank until the level is 1/4" to 1/2" (6 mm to 13 mm) below the bottom of the filler neck. This empty space in the tank allows gasoline to expand.
- Never smoke when handling gasoline, and stay away from an open flame or where gasoline fumes may be ignited by a spark.
- Store gasoline in an approved container and keep it out of the reach of children. Never buy more than a 30-day supply of gasoline.

## Stabilizer/Conditioner

### Toro Stabilizer/Conditioner

Add the correct amount of Toro Gas Stabilizer/Conditioner to the gas. Using Toro Stabilizer/Conditioner or an isopropyl-based conditioner/stabilizer in the machine:

- Keeps gasoline fresh during storage
- Cleans the engine while it runs
- Eliminates gum-like buildup in the fuel system, which causes hard starting

**IMPORTANT: Never use fuel additives containing methanol or ethanol.**

## Filling the Fuel Tank

1. Shut the engine off and open the hood.
2. Clean around the fuel tank cap and remove the cap. Use a funnel and add unleaded regular gasoline to the fuel tank, until the level is 1/4 to 1/2 inch (6 mm to 13 mm) below the bottom of the filler neck. This space in the tank allows gasoline to expand. Do not fill the fuel tank completely full.
3. Install the fuel tank cap securely. Wipe up any gasoline that may have spilled.
4. Close the hood.

## Check Engine Oil Level

Before you start the engine and use the machine, check the oil level in the engine crankcase; refer to Checking Oil Level, page 30.

# Operation

## Think Safety First

Please carefully read all the safety instructions on pages 2-7. Knowing this information could help you, your family, pets or bystanders avoid injury.

## Controls

Become familiar with all the controls (Fig. 1) before you start the engine and operate the machine.

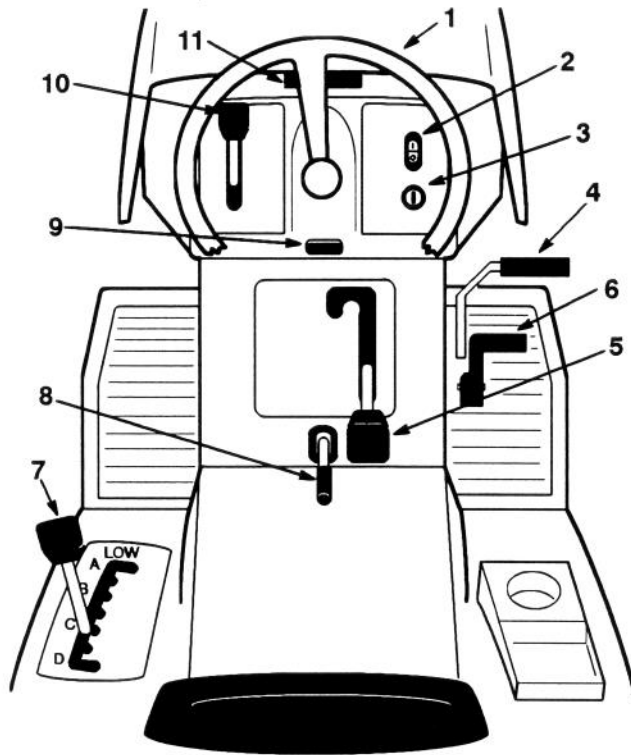

Figure 1

- |  |                                    |
|--|------------------------------------|
| 1. Steering wheel                        | 7. Height-of-cut lever (deck lift) |
| 2. Light switch—on/off (selected models) | 8. Parking brake lever             |
| 3. Ignition switch                       | 9. Tilt button (selected models)   |
| 4. Brake pedal                           | 10. Throttle lever                 |
| 5. Blade control (PTO)                   | 11. Hood opening                   |
| 6. Traction control pedal                |                                    |

## Parking Brake

Always set the parking brake when you stop the machine or leave it unattended.

### Setting the Parking Brake

1. Push the brake pedal (Fig. 2) down and hold it in the depressed position.
2. Lift the parking brake lever (Fig. 2) up and gradually take your foot off the brake pedal. The brake pedal should stay in the depressed (locked) position.

### Releasing the Parking Brake

1. Push down on the brake pedal (Fig. 2). The parking brake lever should release.
2. Gradually release the brake pedal.

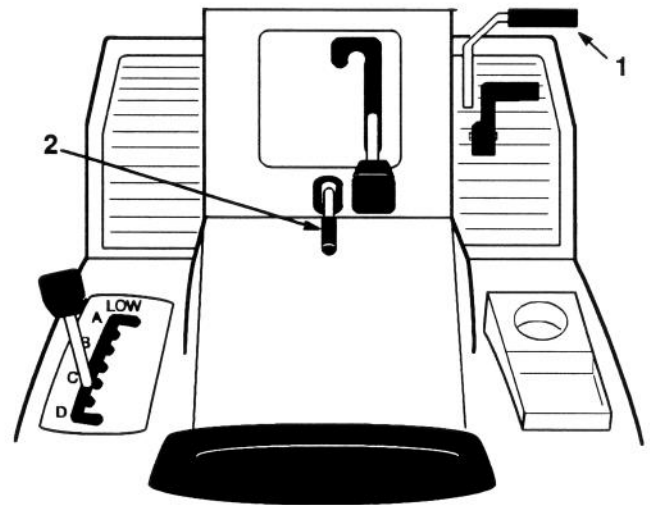

Figure 2

- |                |                        |
|----------------|------------------------|
| 1. Brake pedal | 2. Parking brake lever |
|----------------|------------------------|

## Positioning the Seat

The seat can move forward and backward. Position the seat where you have the best control of the machine and are most comfortable.

1. Raise the seat and loosen the adjustment knob (Fig. 3).
2. Move the seat to the desired position and tighten the knob.

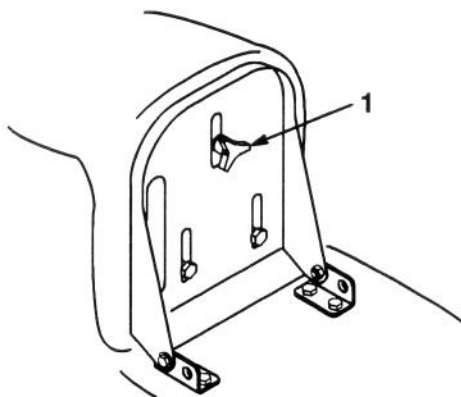

**Figure 3**

1. Adjustment knob

## Positioning the Tilt Steering Wheel

On select models the steering wheel tilts up and down. Position the steering wheel where you have the best control of the machine and are most comfortable.

1. Push in on the tilt button (Fig. 4).
2. Move the steering wheel to any of three positions; then release the button.

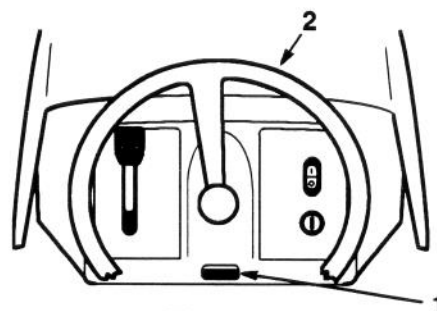

**Figure 4**

1. Tilt button
2. Steering wheel

## Headlights

Headlights are optional on some models. A dash-mounted "ON/OFF" switch (Fig. 1) controls the headlights. The lights only shine while the engine is running and the switch is "ON."

## Using the Blade Control (PTO)

The blade control (PTO) engages and disengages power to the blade(s).

### Engaging the Blade(s)

1. Depress the brake pedal to stop the machine.
2. Move the blade control (PTO) to “ENGAGED” (Fig. 5).

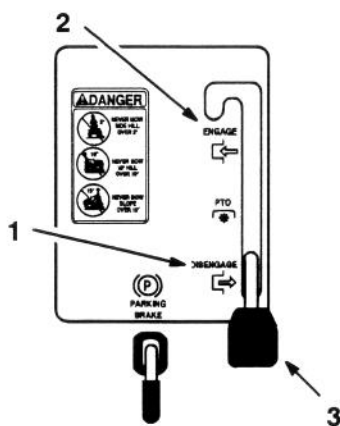

Figure 5

1. Disengaged
2. Engaged
3. Blade control (PTO)

### Disengaging the Blade(s)

1. Depress the brake pedal to stop the machine.
2. Move the blade control (PTO) to “DISENGAGED” (Fig. 5).

## Setting the Height-of-Cut

The height-of-cut lever (deck lift) is used to raise and lower the mower to the desired cutting height.

1. The cutting height may be set in one of seven positions from approximately 1 to 4 inches (25 to 102 mm).
2. Pull on the height-of-cut lever (deck lift) and move it to the desired position (Fig. 6).

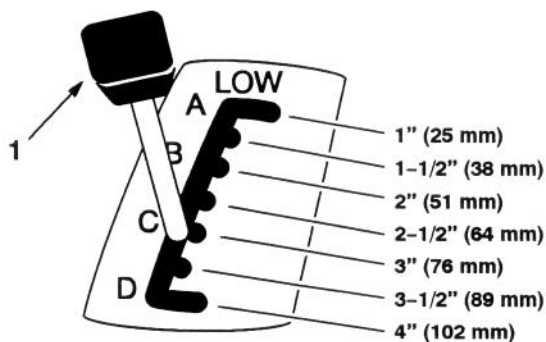

Figure 6

1. Height-of-cut lever (deck lift)

## Starting and Stopping the Engine

### Starting

1. Sit down on the seat.
2. Set the parking brake; refer to Setting the Parking Brake, page 9.

**Note:** The engine will not start unless you set the parking brake or fully depress the brake pedal.

3. Move the blade control (PTO) to “DISENGAGED” (Fig. 8).

4. Move the throttle lever to “CHOKE” (Fig. 9).

**Note:** An engine that has been running and is warm may not require step 4.

5. Turn the ignition key clockwise and hold it in the “START” position (Fig. 7). When the engine starts, release the key.

**IMPORTANT: If the engine does not start after 30 seconds of continuous cranking, turn the ignition key to “OFF” and let the starter motor cool; refer to Troubleshooting, page NO TAG.**

6. After the engine starts, slowly move the throttle lever to “FAST” (Fig. 9). If the engine stalls or hesitates, move the throttle lever back to “CHOKE” for a few seconds. Then move the throttle lever to “FAST.” Repeat this as required.

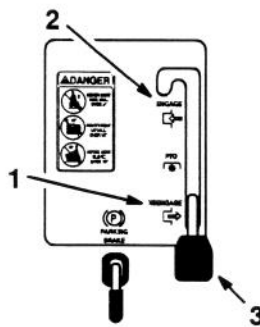

**Figure 8**

1. Disengaged
2. Engaged
3. Blade control (PTO)

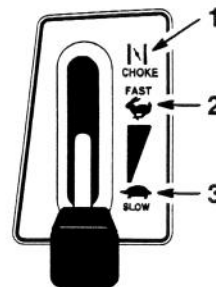

**Figure 9**

1. Choke
2. Fast
3. Slow

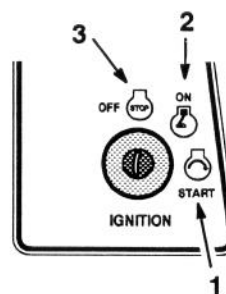

**Figure 7**

1. Start
2. On
3. Off

### Stopping

1. Move the throttle lever to “SLOW” (Fig. 9).
2. Turn the ignition key to “OFF” (Fig. 7).

**Note:** If the engine has been working hard or is hot, let it idle for a minute before turning the ignition key “OFF.” This helps cool the engine before it is stopped. In an emergency, the engine may be stopped by turning the ignition key to “OFF.”

## The Safety System

### Understanding the Safety System

The safety system is designed to prevent the engine from starting unless:

- You are sitting on the seat
- The brake pedal is depressed
- The blade control (PTO) is “DISENGAGED”

The safety system is designed to stop the engine if you rise from the seat when the brake pedal is released or the blade is “ENGAGED.”

### Testing the Safety System

Test the safety system before you use the machine each time. If the safety system does not operate as described below, have an Authorized Service Dealer repair the safety system immediately.

1. Set the parking brake. Move the blade control (PTO) to “ENGAGED.” Now turn the ignition key to “START”; the engine should not crank.
2. Move the blade control (PTO) to “DISENGAGED” and release the parking brake. Now turn the ignition key to “START”; the engine should not crank.
3. Set the parking brake and move the blade control (PTO) to “DISENGAGED.” Now start the engine. While the engine is running, release the parking brake and rise slightly from the seat; the engine should stop.

## Pushing the Machine by Hand

**IMPORTANT:** Always push the machine by hand. Never tow the machine because transaxle damage may occur.

### To Push the Machine

1. Disengage the blade control (PTO), set the parking brake, and turn the ignition key to “OFF” to stop the engine.
2. Pull the drive control wire back to the “PUSH” position. This disengages the drive system and allows the wheels to turn freely (Fig. 10).

### To Operate the Machine

1. Push the drive control wire forward to the “OPERATE” position. This engages the drive system (Fig. 10).

**Note:** The machine will not drive unless the drive control wire is in the “OPERATE” position.

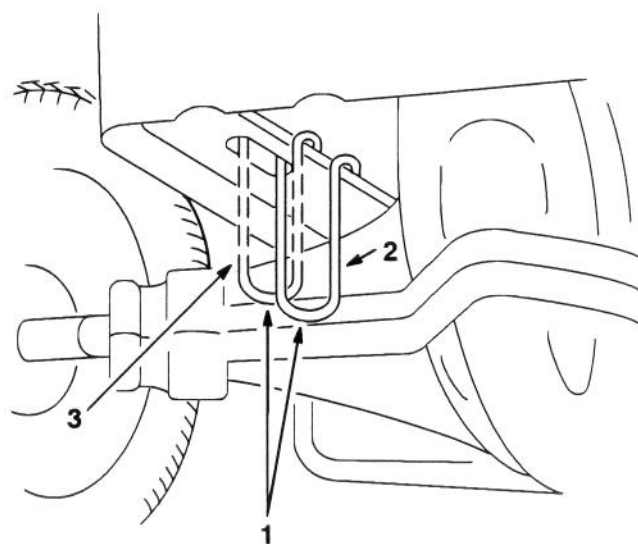

**Figure 10**

- |                       |                  |
|-----------------------|------------------|
| 1. Drive control wire | 3. Push position |
| 2. Operate position   |                  |

## Driving Forward or Backward

The throttle control regulates the engine speed as measured in rpm (revolutions per minute). Place the throttle control in the “FAST” position for best performance.

To go forward or backward, release the parking brake: refer to Releasing the Parking Brake, page 9. Place your foot on the traction control pedal and slowly press on the top of the traction control pedal to move forward or on the bottom of the traction control pedal to move backward (Fig. 11). The farther you move the traction control pedal in either direction, the faster the machine will move in that direction.

To slow down release the pressure on the traction control pedal.

**IMPORTANT: To avoid transmission damage, always release the parking brake before moving the traction control pedal.**

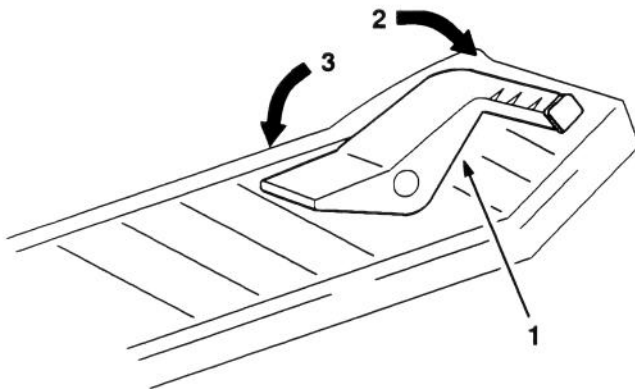

**Figure 11**

- 1. Traction control pedal
- 2. Forward
- 3. Backward

## Stopping the Machine

To stop the machine, release the traction control pedal, disengage the blade control (PTO), and turn the ignition key to “OFF” to stop the engine. Also set the parking brake if you leave the machine unattended; refer to Setting the Parking Brake, page 9. Remember to remove the key from the ignition switch.

### CAUTION

#### POTENTIAL HAZARD

- Someone could move or attempt to operate the tractor while it is unattended.

#### WHAT CAN HAPPEN

- Children or bystanders may be injured if they use the tractor.

#### HOW TO AVOID THE HAZARD

- Always remove the ignition key and set the parking brake when leaving the machine unattended, even if just for a few minutes.

## Side Discharge or Mulch Grass

### **!** DANGER

#### POTENTIAL HAZARD

- Without the grass deflector, discharge cover, or complete grass catcher assembly mounted in place, you and others are exposed to blade contact and thrown debris.

#### WHAT CAN HAPPEN

- Contact with rotating mower blade(s) and thrown debris will cause injury or death.

#### HOW TO AVOID THE HAZARD

- NEVER remove the grass deflector from the mower because the grass deflector routes material down toward the turf. If the grass deflector is ever damaged, replace it immediately.
- Never put your hands or feet under the mower.
- Never try to clear discharge area or mower blades unless you move the blade control (PTO) to "DISENGAGED" and rotate the ignition key to "OFF." Also remove the key and pull the wire off the spark plug.

1. The mower has a hinged grass deflector that disperses clippings to the side and down toward the turf.
2. To mulch grass clippings you must install the discharge cover (optional on some models) into the opening in the side of the mower; refer to Installing the Discharge Cover, page 15.

## Installing the Discharge Cover

To convert from side discharge to a mulching mower, install the discharge cover into the opening at the side of the mower.

1. Lift the grass deflector and slide the tabs on top of the discharge cover under the grass deflector retaining rod. Rotate the discharge cover down over the opening, and onto the lower lip of the mower (Fig. 12).
2. Secure the discharge cover to the lower lip of the mower with bolts and nuts (Fig. 12).

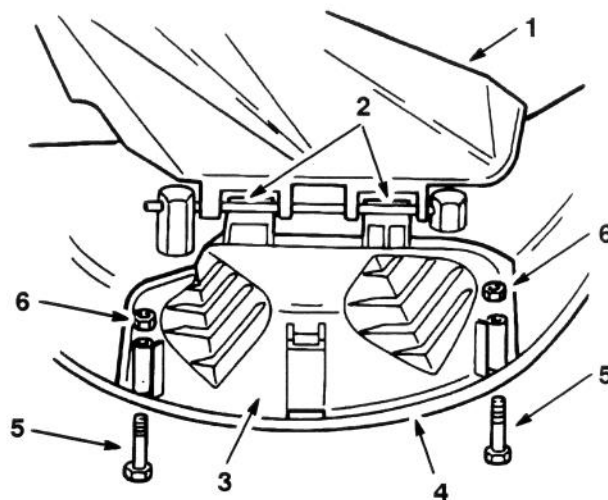

Figure 12

- |                    |              |
|--------------------|--------------|
| 1. Grass deflector | 4. Lower lip |
| 2. Tabs under rod  | 5. Bolt      |
| 3. Discharge cover | 6. Nut       |
3. To convert back to a side discharge mower, remove the discharge cover and lower the grass deflector over the discharge opening.

## Tips for Mowing Grass

### Fast Throttle Setting

For best mowing and maximum air circulation, operate the engine at "FAST." Air is required to thoroughly cut grass clippings, so do not set the height-of-cut too low or totally surround the mower by uncut grass. Always try to have one side of the mower free from uncut grass, which allows air to be drawn into the mower.

### Cutting a Lawn for the First Time

Cut grass slightly longer than normal to ensure the cutting height of the mower does not scalp any uneven ground. However, the cutting height used in the past is generally the best one to use. When cutting grass longer than six inches tall, you may want to cut the lawn twice to assure an acceptable quality-of-cut.

### Cut 1/3 of the Grass Blade

It is best to cut only about 1/3 of the grass blade. Cutting more than that is not recommended, unless grass is sparse or it is late fall when grass grows more slowly.

### Mowing Direction

Alternate mowing direction to keep the grass standing straight. This also helps disperse clippings which enhances decomposition and fertilization.

### Mow at Correct Intervals

Normally, mow every 4 days. But remember, grass grows at different rates at different times. So to maintain the same cutting height, which is a good practice, mow more often in early spring. As the grass growth rate slows in mid summer, mow less frequently. If you cannot mow for an extended period, first mow at a high cutting height; then mow again 2 days later at a lower height setting.

### Avoid Cutting Too Low

If the cutting width of the mower is wider than the mower you previously used, raise the cutting height one notch to ensure uneven turf is not cut too short.

### Long Grass

If the grass is ever allowed to grow slightly longer than normal, or if it contains a high degree of moisture, raise the cutting height higher than usual and cut the grass at this setting. Then cut the grass again using the lower, normal setting.

### When Stopping

If the machine's forward motion must be stopped while mowing, a clump of grass clippings may drop onto your lawn. To avoid this:

1. With the blade(s) "ENGAGED," move onto a previously cut area.
2. To disperse the clippings evenly, raise the mower one or two height-of-cut settings while driving forward with the blade(s) "ENGAGED."

### Keep the Underside of the Mower Clean

Clean clippings and dirt from the underside of the mower after each use. If grass and dirt build up inside the mower, cutting quality will eventually become unsatisfactory.

### Blade Maintenance

Maintain a sharp blade throughout the cutting season because a sharp blade cuts cleanly without tearing or shredding the grass blades. Tearing and shredding turns grass brown at the edges, which slows growth and increases the chance of disease. Every 30 days, check the cutter blade(s) for sharpness and file down any nicks.

# Maintenance

## Service Interval Chart

Service Operation	Each Use	5 Hours	25 Hours	Storage Service	Spring Service	Notes
Oil—initial change		X				
Oil—periodic change			X	X		
Oil—check level	X					
Safety System—check	X	X	X		X	
Cutter Blade—check		X	X	X		
Brake—check		X	X	X	X	
Chassis—grease			X	X		More often in dusty, dirty conditions
Foam Air Cleaner—service			X	X		
Paper Air Cleaner—replace				X		
Spark Plug—check			X	X	X	
Belts—check for wear/cracks				X		
Gasoline—drain				X		
Engine—clean outside			X	X		
Mower Housing—clean	X	X		X		
Chipped Surfaces—paint				X		
Battery—check electrolyte	X	X	X	X	X	
Battery—charge, disconnect cables				X		
Fuel Filter—replace				X		
Tires—check pressure			X	X	X	

### CAUTION

#### POTENTIAL HAZARD

- If you leave the key in the ignition switch, someone could start the engine.

#### WHAT CAN HAPPEN

- Accidental starting of the engine could seriously injure you or other bystanders.

#### HOW TO AVOID THE HAZARD

- Remove the key from the ignition switch and pull the wire off the spark plug before you do any maintenance. Also push the wire aside so it does not accidentally contact the spark plug.

## Greasing and Lubrication

### Service Interval/Specification

Grease the machine after every 25 operating hours or once a year, whichever occurs first. Grease more frequently when operating conditions are extremely dusty or sandy.

Grease Type: General-purpose grease.

### How to Grease

1. Disengage the blade control (PTO), set the parking brake, and turn the ignition key to "OFF" to stop the engine.
2. Clean the grease fittings with a rag. Make sure to scrape any paint off the front of the fitting(s).
3. Connect a grease gun to the fitting. Pump grease into the fittings.
4. Wipe up any excess grease.

### Where to Add Grease

1. Lubricate the front wheels until grease begins to ooze out the bearings (Fig. 13).

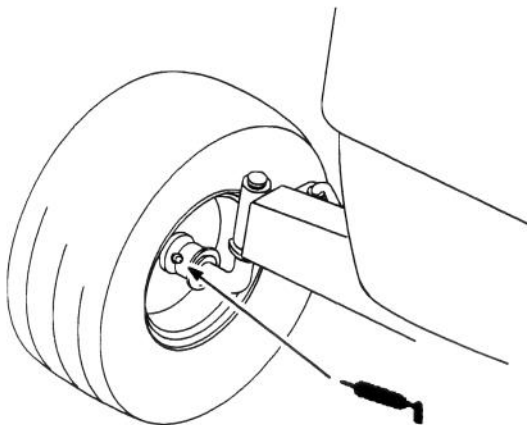

Figure 13

---

## Tire Pressure

### Service Interval/Specification

Maintain the air pressure in the front and rear tires as specified. Check the pressure at the valve stem after every 25 operating hours or yearly, whichever occurs first (Fig. 14). Check the tires when they are cold to get the most accurate pressure reading.

Pressure: 12 psi (.85 kPa) front and rear

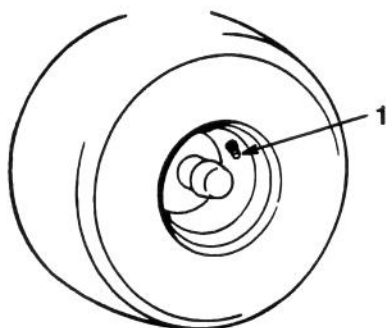

**Figure 14**

1. Valve stem

## Brake

The brake is on the right side of the rear axle, inside the rear tire (Fig. 15). If the parking brake does not hold securely, an adjustment is required.

### Checking the Brake

1. Park the machine on a level surface, disengage the blade control (PTO), set the parking brake, and turn the ignition key to "OFF" to stop the engine.
2. Move the drive control wire to the "PUSH" position; refer to Pushing the Machine by Hand, page 13.
3. If the rear wheels lock and skid when you push the tractor forward, no adjustment is required. An adjustment is required if the wheels turn and do not lock; refer to Adjusting the Brake, page 19.

### Adjusting the Brake

(0.020" (5.08 mm) feeler gauge required)

1. Check the brake before you adjust it; refer to Checking the Brake, page 19.
2. Release the parking brake; refer to Releasing the Parking Brake, page 9.
3. To adjust the brake loosen the brake adjusting nut slightly (Fig. 15).
4. Carefully insert a 0.020" (5.08 mm) feeler gauge between the two outer brake pads (Fig. 15).
5. Tighten the brake adjusting nut until slight resistance is felt on the feeler gauge when sliding it in and out.
6. Check the brake operation again; refer to Checking the Brake, page 19.

**IMPORTANT:** With the parking brake released, the rear wheels must rotate freely when you push the mower. If the 0.020" (5.08 mm) clearance and free wheel rotation cannot be achieved contact your service dealer immediately.

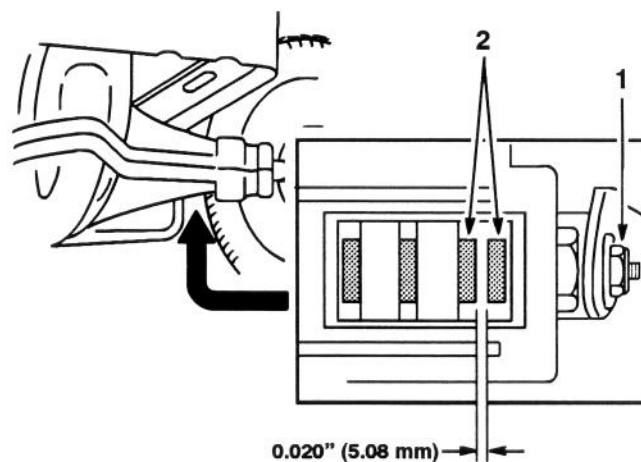
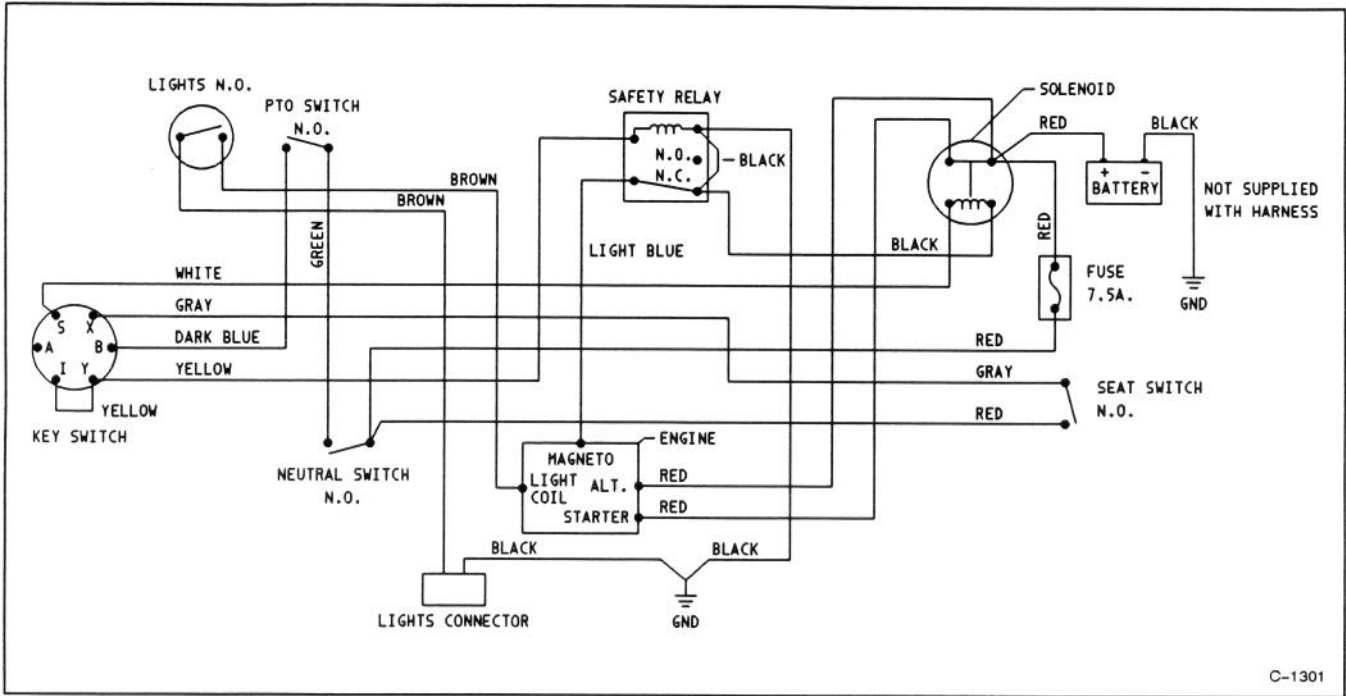

**Figure 15**

1. Brake adjusting nut

2. Outer brake pads

# Wiring Diagram



C-1301

## Fuse

### Service Interval/Specification

The electrical system is protected by a fuse. It requires no maintenance, however if the fuse blows the starter will not crank. To replace the fuse pull up on the fuse (Fig. 16) to remove or replace it.

Fuse: 7.5 amp, blade-type

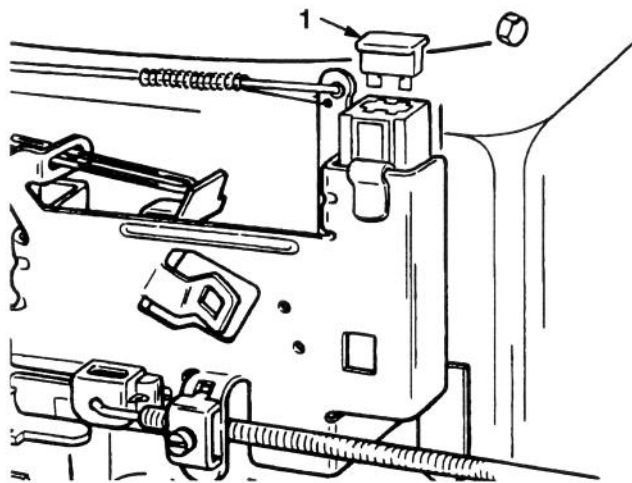

**Figure 16**

1. Fuse (removed)

## Headlights

Specification: Bulb # 1156

### Removing the Bulb

1. Disengage the blade control (PTO), set the parking brake, and turn the ignition key to "OFF" to stop the engine.
2. Open the hood. Pull wire connectors off both bulb holder terminals.
3. Rotate the bulb holder 1/4 turn counterclockwise and remove it from the reflector (Fig. 17).
4. Push and rotate the bulb counterclockwise until it stops (approx. 1/4 turn) and remove bulb from the bulb holder (Fig. 18).

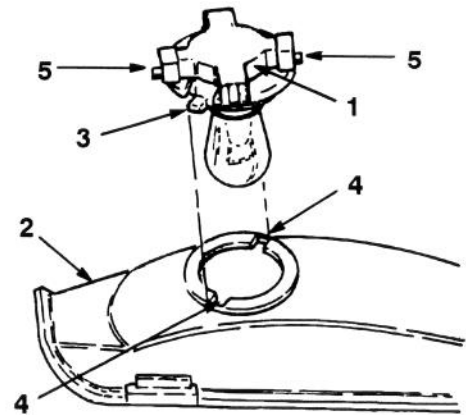
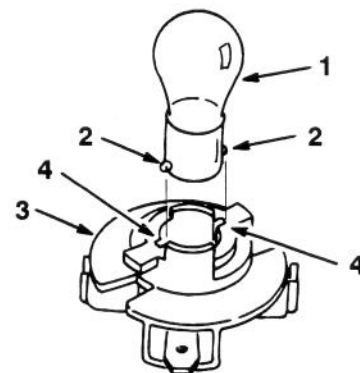

**Figure 17**

- |                |              |
|----------------|--------------|
| 1. Bulb holder | 4. Slots     |
| 2. Reflector   | 5. Terminals |
| 3. Tabs        |              |

### Installing the Bulb

1. The bulb has metal pins on the side of its base. Align the pins with the slots in the bulb holder and insert the base into the holder (Fig. 18). Push and rotate the bulb clockwise until it stops.



**Figure 18**

- |               |                |
|---------------|----------------|
| 1. Bulb       | 3. Bulb holder |
| 2. Metal pins | 4. Slots       |

2. The bulb holder has two tabs (Fig. 17). Align the tabs with the slots in the reflector, insert the bulb holder into the reflector and rotate it 1/4 turn clockwise until it stops.
3. Push the wire connectors onto the terminals on the bulb holder.

## Battery

### Service Interval/Specification

Check the electrolyte level in the battery before each use. Always keep the battery clean and fully charged. Use a paper towel to clean the battery and battery box. If the battery terminals are corroded, clean them with a solution of four parts water and one part baking soda. Apply a light coating of grease to the battery terminals to prevent corrosion.

Voltage: 12 v, 160 Cold Cranking Amps

### Removing the Battery

1. Disengage the blade control (PTO), set the parking brake, and turn the ignition key to "OFF" to stop the engine.
2. Tip the seat forward to see the battery.
3. Disconnect the negative (black) ground cable from the battery post (Fig. 19).
4. Slide the rubber cover up the positive (red) cable. Disconnect the positive (red) cable from the battery post (Fig. 19).
5. Remove the battery box, battery, and long vent tube from the chassis (Fig. 20).

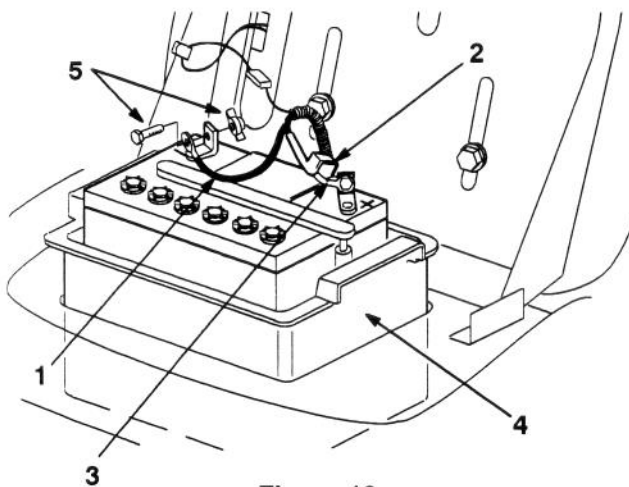

Figure 19

- |                           |                      |
|---------------------------|----------------------|
| 1. Negative cable (black) | 4. Battery box       |
| 2. Rubber cover           | 5. Bolt and wing nut |
| 3. Positive cable (red)   |                      |

### Installing the Battery

1. Put the battery into the battery box and slide the vent tube into the channel and through the slot in the bottom of the box (Fig. 20).

**IMPORTANT: Look down into the cut out area where the battery box fits into the chassis. Notice the hole at the end of the right frame member (Fig. 20). Always install the long battery vent tube through the hole to prevent battery acid from corroding the tractor and mower.**

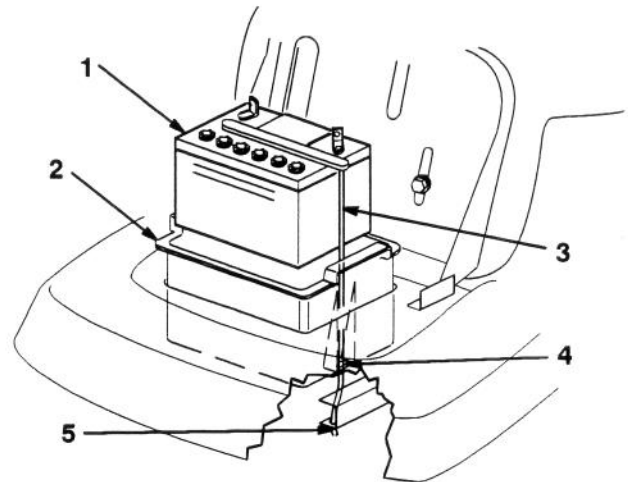

Figure 20

- |                |                        |
|----------------|------------------------|
| 1. Battery     | 4. Slot in battery box |
| 2. Battery box | 5. Hole in frame       |
| 3. Vent tube   |                        |
2. Install the battery box and battery into the chassis (Fig. 20). Make sure to slide the end of the vent tube through the hole in the frame (Fig. 20).
  3. Using the bolt and wing nut, connect the positive (red) cable to the positive (+) battery post (Fig. 19). Slide the rubber cover over the battery post.
  4. Using the bolt and wing nut, connect the negative (black) cable to the negative (-) battery post (Fig. 19).

## Checking Electrolyte Level

1. Tip the seat forward to see the battery.
2. Look at the side of the battery. The electrolyte must be up to the “UPPER” line (Fig. 21). Do not allow the electrolyte to get below the “LOWER” line (Fig. 21).
3. If the electrolyte is low, add the required amount of distilled water; refer to Adding Water to the Battery, page 23.

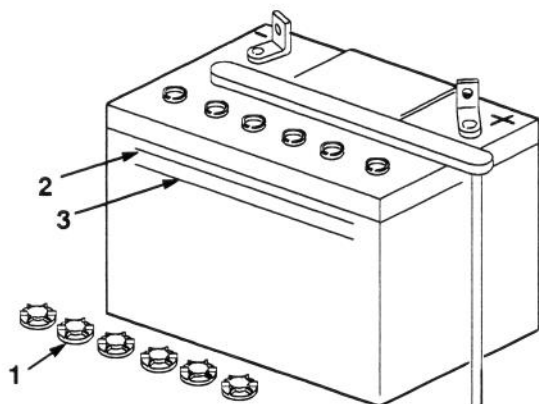

Figure 21

1. Filler caps
2. UPPER line
3. LOWER line

## Adding Water to the Battery

The best time to add distilled water to the battery is just before you operate the machine. This lets the water mix thoroughly with the electrolyte solution.

1. Clean the top of the battery with a paper towel.
2. Unscrew the filler caps (Fig. 21).
3. Slowly pour distilled water into each battery cell until the level is up to the “UPPER” line (Fig. 21) on the battery case.

**IMPORTANT: Do not overfill the battery because electrolyte (sulfuric acid) can cause severe corrosion and damage to the chassis.**

4. Screw the filler caps onto the battery.

## Charging the Battery

**IMPORTANT: Always keep the battery fully charged (1.260 specific gravity). This is especially important to prevent battery damage when the temperature is below 32°F (0°C).**

1. Remove the battery from the chassis; refer to Removing the Battery, page 22.
2. Check the electrolyte level; refer to Checking Electrolyte Level, page 23, steps 2–3.
3. Remove the filler caps from the battery and connect a 3 to 4 amp battery charger to the battery posts. Charge the battery at a rate of 4 amperes or less for 4 hours (12 volts). Do not overcharge the battery. Install the filler caps after the battery is fully charged.

### WARNING

#### POTENTIAL HAZARD

- Charging the battery produces gasses.

#### WHAT CAN HAPPEN

- Battery gasses can explode.

#### HOW TO AVOID THE HAZARD

- Keep cigarettes, sparks and flames away from battery.

4. Install the battery in the chassis; refer to Installing the Battery, page 22.

## Spark Plug

### Service Interval/Specification

Install a new spark plug after every 100 operating hours. Check the spark plug after every 25 operating hours. Make sure the air gap between the center and side electrodes is correct before installing the spark plug. Use a spark plug wrench for removing and installing the spark plug and a gapping tool/feeler gauge to check and adjust the air gap.

Type: Champion RJ-19LM (or equivalent)  
Air Gap: 0.030" (0.762 mm)

### Removing the Spark Plug

1. Disengage the blade control (PTO), set the parking brake, and turn the ignition key to "OFF" to stop the engine.
2. Open the hood.
3. Pull the wire off the spark plug (Fig. 22). Now clean around the spark plug to prevent dirt from falling into the engine and potentially causing damage.
4. Remove the spark plug and metal washer.

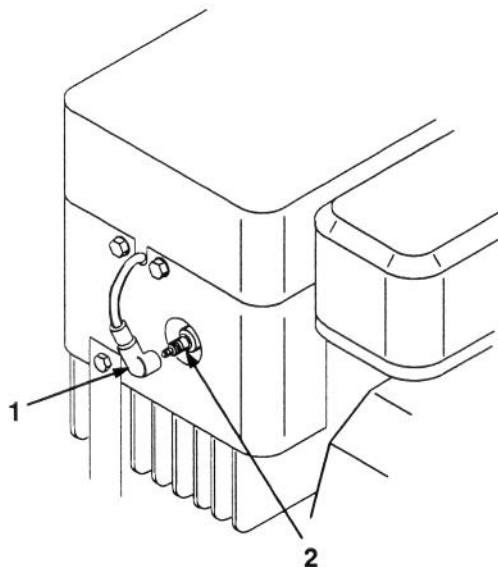

Figure 22

1. Spark plug wire
2. Spark plug

### Checking the Spark Plug

1. Look at the center of the spark plug (Fig. 23). If you see light brown or gray on the insulator, the engine is operating properly. A black coating on the insulator usually means the air cleaner is dirty.

**IMPORTANT: Never clean the spark plug. Always replace the spark plug when it has: a black coating, worn electrodes, an oily film, or cracks.**

2. Check the gap between the center and side electrodes (Fig. 23). Bend the side electrode (Fig. 23) if the gap is not correct.

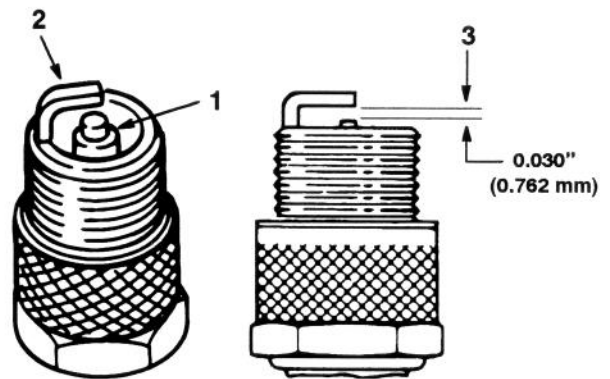

Figure 23

1. Center electrode insulator
2. Side electrode
3. Air gap (not to scale)

### Installing the Spark Plug

1. Install the spark plug and metal washer. Make sure the air gap is set correctly.
2. Tighten the spark plug to 15 ft-lb (20.4 Nm).
3. Push the wire onto the spark plug (Fig. 22).
4. Close the hood.

## Fuel Tank

### Draining The Fuel Tank

#### DANGER

##### POTENTIAL HAZARD

- In certain conditions gasoline is extremely flammable and highly explosive.

##### WHAT CAN HAPPEN

- A fire or explosion from gasoline can burn you, others, and cause property damage.

##### HOW TO AVOID THE HAZARD

- Drain gasoline from the fuel tank when the engine is cold. Do this outdoors in an open area. Wipe up any gasoline that spills.
- Never drain gasoline near an open flame or where gasoline fumes may be ignited by a spark.
- Never smoke a cigarette, cigar or pipe.

1. Park the machine so that the left front side is slightly lower than the right side to assure fuel tank drains completely. Then disengage the blade control (PTO), set the parking brake, and turn the ignition key to "OFF" to stop the engine.
2. Open the hood.
3. Squeeze the ends of the hose clamp together and slide it up the fuel line toward the fuel tank (Fig. 24).
4. Pull the fuel line off the filter (Fig. 24) and allow gasoline to drain into a gas can or drain pan.

**Note:** Now is the best time to install a new fuel filter because the fuel tank is empty.

5. Install the fuel line onto the filter. Slide the hose clamp close to the filter to secure the fuel line and filter.

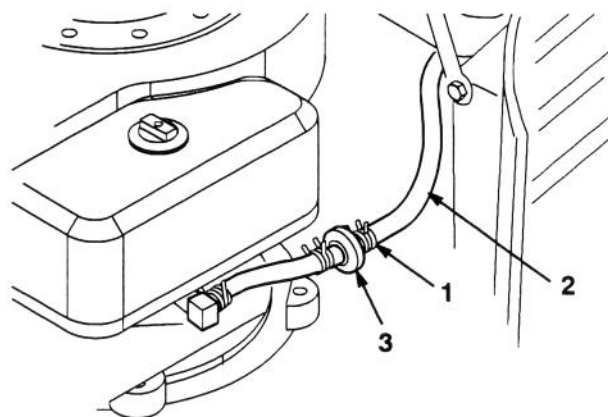

Figure 24

- |               |           |
|---------------|-----------|
| 1. Hose clamp | 3. Filter |
| 2. Fuel line  |           |

## Fuel Filter

### Service Interval/Specification

Replace the fuel filter after every 100 operating hours or yearly, whichever occurs first.

### Replacing the Fuel Filter

The best time to replace the fuel filter (Fig. 24) is when the fuel tank is empty. Never install a dirty filter if it is removed from the fuel line.

1. Disengage the blade control (PTO), set the parking brake, and turn the ignition key to "OFF" to stop the engine.
2. Open the hood.
3. Squeeze the ends of the hose clamps together and slide them away from the filter (Fig. 24).
4. Remove the filter from the fuel lines.
5. Install a new filter and move the hose clamps close to the filter.
6. Close the hood.

## Throttle and Choke Control

Normally the throttle and choke control does not require adjustment. However, you should check the control adjustment:

- Before adjusting the carburetor
- If the engine starts hard

### Checking and Adjusting the Throttle and Choke Control

1. Disengage the blade control (PTO), set the parking brake, and turn the ignition key to "OFF" to stop the engine
2. Open the hood.
3. Checking Throttle Setting
  - A. Move the dash-mounted throttle lever to "SLOW" and back to "FAST." The lever must snap into a notch.
  - B. With the throttle in the "FAST" position, index holes in the governor control lever and the governor plate must align (Fig. 25). If they do not align, refer to step 4 for adjustment procedure.

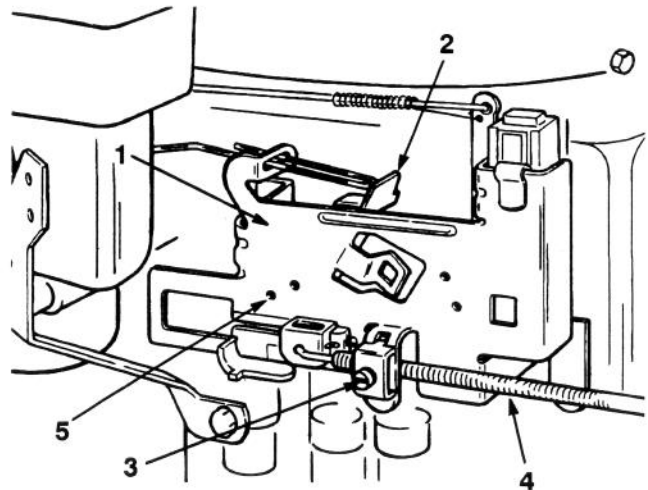

Figure 25

- |                           |                          |
|---------------------------|--------------------------|
| 1. Governor plate         | 4. Throttle cable casing |
| 2. Governor control lever | 5. Index hole            |
| 3. Screw                  |                          |
4. Adjusting the Throttle
    - A. Make sure the dash-mounted throttle lever is in the "FAST" notch.
    - B. Loosen the throttle cable clamp screw until you can slide the throttle cable casing (Fig. 25).
    - C. Move the throttle cable casing until the index holes in the governor control lever and the governor plate align (Fig. 25). Now tighten the cable clamp screw.
    - D. Check the throttle setting; refer to steps 3A and 3B.

## Carburetor

To adjust the carburetor, you will need a tachometer to set the idle speed. If you do not have a tachometer or the special knowledge required to adjust the carburetor, contact an authorized service dealer.

**IMPORTANT: Before you adjust the carburetor:** (1) check the throttle control and adjust it if required; refer to **Throttle and Choke Control**, page 26, and (2) check the air cleaner and clean it if required; refer to **Air Cleaner**, page 28.

### WARNING

#### POTENTIAL HAZARD

- The engine must be running for you to adjust the carburetor. This potentially could be unsafe.

#### WHAT CAN HAPPEN

- If you contact a rotating blade or engine blower screen, touch a hot muffler, or the tractor accidentally moves, you or bystanders could be seriously injured or killed.

#### HOW TO AVOID THE HAZARD

- Although the engine must be running, set the parking brake, and disengage the blade control (PTO). Do not touch rotating engine blower screen or the hot muffler.

#### 1. Initial Adjustment

- Gently turn the idle mixture screw (Fig. 26) clockwise until it just closes. Do not force (tighten) the idle mixture screw because the carburetor could be damaged.
- Open the idle mixture screw (Fig. 26) one turn counterclockwise. This setting allows you to start the engine.
- Start the engine, move the throttle to "SLOW" and let the engine idle for five minutes.

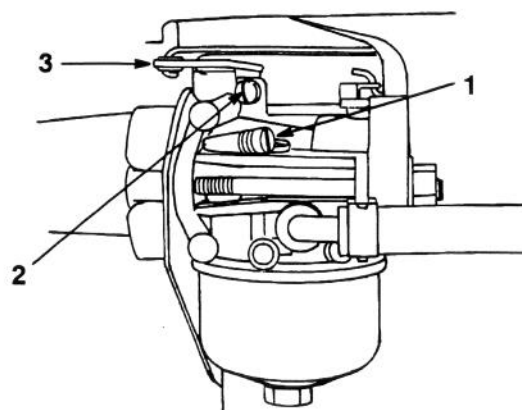

Figure 26

- Idle mixture screw
- Idle speed screw
- Throttle arm

#### 2. Final Adjustment

- Hold the carburetor throttle arm against the idle speed screw (Fig. 26). Adjust the idle speed screw so the engine idles at 1750 rpm. Check the rpm with a tachometer.
- While you continue holding the throttle arm against the idle speed screw, slowly turn the idle mixture screw (Fig. 26) in (clockwise) until the engine begins to slow (lean mixture). Next, turn the idle mixture screw out (counterclockwise) until the engine begins to run roughly (rich mixture).
- Now rotate the idle mixture screw (Fig. 26) midway between the lean and rich mixture until the engine runs smoothly.
- Make sure the idle speed is still 1750 rpm. Adjust the idle speed screw if required; step 2A.
- Move the dash-mounted throttle lever from "SLOW" to "FAST." If the engine does not accelerate smoothly, turn the idle mixture screw counterclockwise to a slightly richer mixture.

477

## Air Cleaner

### Service Interval/Specification

Foam Element: Clean and re-oil after every 25 operating hours, or yearly, whichever occurs first.

Paper Element: Replace after every 100 operating hours or yearly, whichever occurs first.

**Note:** Service the air cleaner more frequently (every few hours) if operating conditions are extremely dusty or sandy.

### Removing the Foam and Paper Elements

1. Disengage the blade control (PTO), set the parking brake, and turn the ignition key to "OFF" to stop the engine.
2. Open the hood.
3. Clean around the air cleaner to prevent dirt from getting into the engine and causing damage. Unscrew the knob and remove the air cleaner cover (Fig. 27).

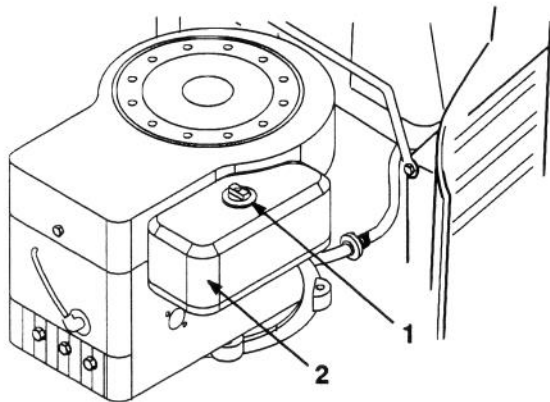

Figure 27

1. Knob
2. Air cleaner cover

4. Carefully slide the foam element off the paper element (Fig. 28).

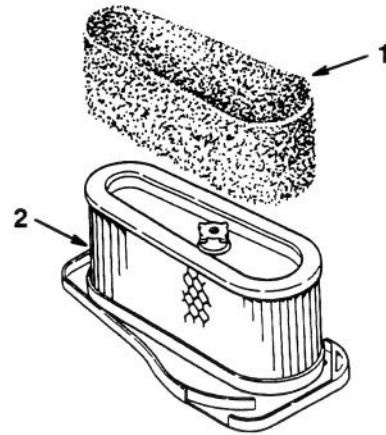

Figure 28

1. Foam element
2. Paper element

5. Unscrew the rubber nut and remove the paper element (Fig. 29).

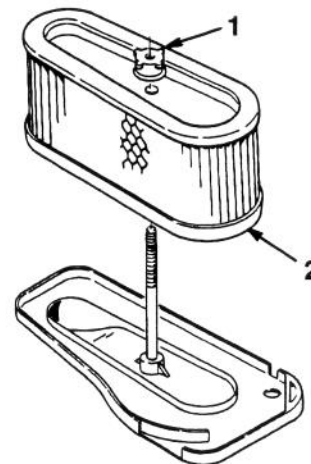

Figure 29

1. Rubber nut
2. Paper element

## Cleaning the Foam and Paper Elements

### 1. Foam Element

- A. Wash the foam element in liquid soap and warm water. When the element is clean, rinse it thoroughly.
- B. Dry the element by squeezing it in a clean cloth.
- C. Put one or two ounces of oil on the element (Fig. 30). Squeeze the element to distribute the oil.

**IMPORTANT: Replace the foam element if it is torn or worn.**

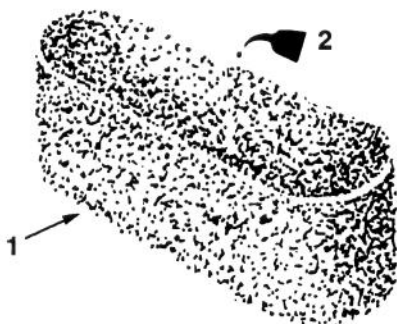

**Figure 30**

1. Foam element
2. Oil

### 2. Paper Element

- A. Lightly tap the element on a flat surface to remove dust and dirt (Fig. 31).
- B. Inspect the element for tears, an oily film, and damage to the rubber seal.

**IMPORTANT: Never clean the paper element with pressurized air or liquids, such as solvent, gas, or kerosene. Replace the paper element if it is damaged, defective, or cannot be cleaned thoroughly.**

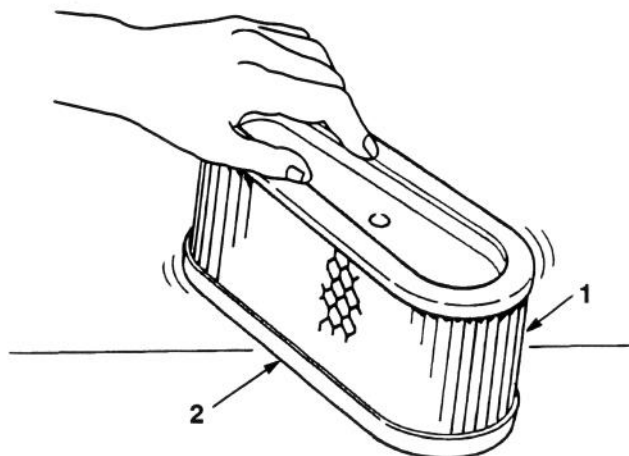

**Figure 31**

1. Paper element
2. Rubber seal

## Installing the Foam and Paper Elements

**IMPORTANT: To prevent engine damage, always operate the engine with the complete foam and paper air cleaner assembly installed.**

1. Carefully slide the foam element onto the paper air cleaner element (Fig. 28).
2. Slide the air cleaner assembly onto the long rod. Now screw the rubber nut finger-tight against the air cleaner (Fig. 29).

**Note:** Make sure the rubber seal is flat against the air cleaner base.

3. Install the air cleaner cover and knob (Fig. 27). Tighten the knob snugly.
4. Close the hood.

## Engine Oil

### Service Interval/Specification

Change oil:

- After the first 5 operating hours.
- After every 25 operating hours.

**Note:** Change oil more frequently when operating conditions are extremely dusty or sandy.

Oil Type: Detergent oil (API service SE, SF or SG)

Crankcase Capacity: 48 oz/1-1/2 qt (1400 cc/1.4 l)

Viscosity: See table below

#### USE THESE SAE VISCOSITY OILS

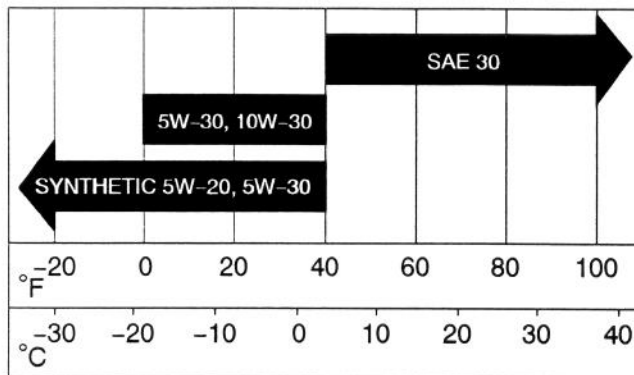

### Checking Oil Level

1. Park the machine on a level surface, disengage the blade control (PTO), set the parking brake, and turn the ignition key to "OFF" to stop the engine.
2. Open the hood.
3. Clean around the oil dipstick (Fig. 32) so dirt cannot fall into the filler hole and damage the engine.
4. Unscrew the oil dipstick and wipe the metal end clean (Fig. 32).

5. Screw the oil dipstick fully onto the filler tube (Fig. 32). Unscrew the dipstick again and look at the metal end. If oil level is low, slowly pour only enough oil into the filler tube to raise the level to the "FULL" mark.

**IMPORTANT: Do not overfill the crankcase with oil because the engine may be damaged.**

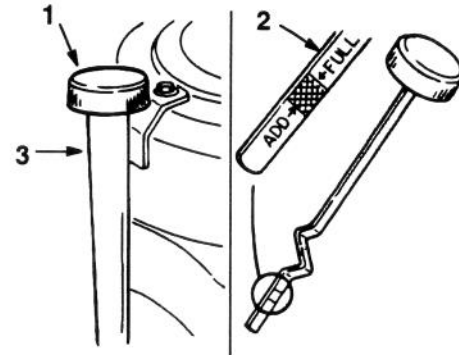

Figure 32

1. Oil dipstick
2. Metal end
3. Filler tube

### Changing/Draining Oil

1. Start the engine and let it run five minutes. This warms the oil so it drains better.
2. Park the machine so that the right front side is slightly lower than the left side to assure the oil drains completely. Then disengage the blade control (PTO), set the parking brake, and turn the ignition key to "OFF" to stop the engine.
3. Open the hood.
4. Place a pan below the oil dipstick/fill tube and remove the drain plug (Fig. 33).
5. When oil has drained completely, install the drain plug.

**Note:** Dispose of the used oil at a certified recycling center.

6. Slowly pour approximately 80% of the specified amount of oil into the filler tube (Fig. 32). Now check the oil level; refer to Checking Oil Level, page 30, steps 4-5.

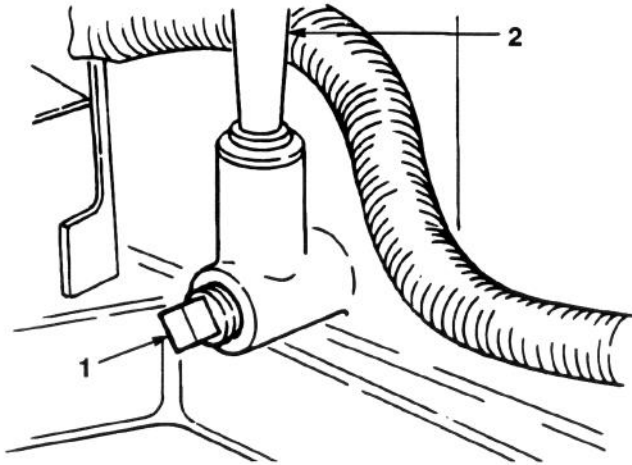

**Figure 33**

1. Oil drain plug
2. Oil dipstick/fill tube

## Cutting Blade

To assure a superior quality of cut, keep the blade(s) sharp. For convenient sharpening and replacement, you may want to have an extra blade(s).

### WARNING

#### POTENTIAL HAZARD

- A blade that is worn or damaged could break apart and pieces could be thrown at bystanders or at you as you use the mower.

#### WHAT CAN HAPPEN

- Pieces of blade that may be thrown could seriously injure or kill you or bystanders.

#### HOW TO AVOID THE HAZARD

- Periodically inspect the blade for wear and damage. Immediately install a new blade if it is worn or damaged.

### Inspecting the Blade(s)

1. Remove the mower; refer to Removing the Mower, page 34.
2. Inspect the cutting edges (Fig. 34). If the edges are not sharp or have nicks, remove the blade(s) and sharpen them; refer to Sharpening the Blade(s), page 33.
3. Inspect the blade(s), especially the curved area (Fig. 34). If you notice any damage, wear, or a slot forming in this area (Fig. 34), immediately install a new blade.

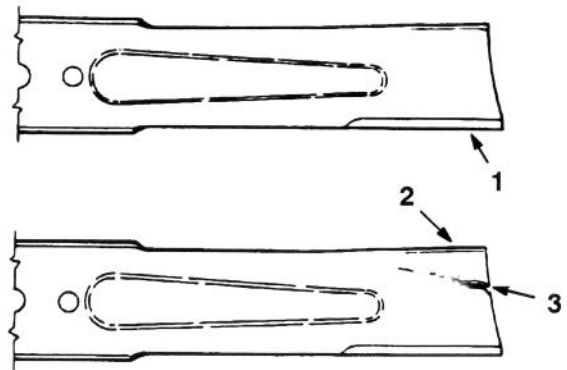

Figure 34

1. Cutting edge
2. Curved area
3. Wear/slot forming

151

### Removing the Blade

1. Remove the mower; refer to Removing the Mower, page 34.
2. Carefully tip the mower over.
3. Remove the bolt (5/8" wrench), curved washer, retainer and blade (Fig. 35). A block of wood may be wedged between the blade and the mower to lock the blade when you are removing the bolt.
4. Inspect all parts. If a defect or damage is noticed, install new parts.

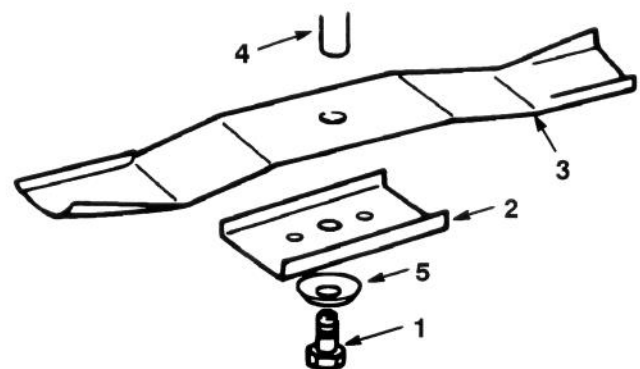
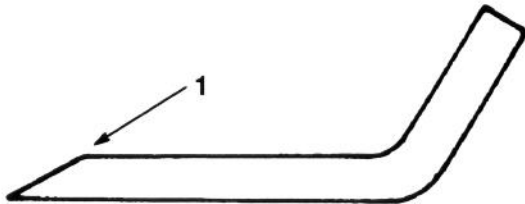

Figure 35

1. Bolt
2. Retainer
3. Blade
4. Spindle
5. Curved washer

## Sharpening the Blade(s)

1. Use a file to sharpen the cutting edge at both ends of the blade (Fig. 36). Maintain the original angle. The blade retains its balance if the same amount of material is removed from both cutting edges.



**Figure 36**

1. Sharpen at original angle

2. Check the balance of the blade by putting it on a blade balancer (Fig. 37). If the blade stays in a horizontal position, the blade is balanced and can be used. If the blade is not balanced, file some metal off the back side of the blade. Repeat this procedure until the blade is balanced.

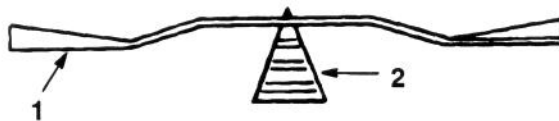

**Figure 37**

1. Blade
2. Balancer

## Installing the Blade(s)

1. Install the blade, blade retainer, curved washer (cupped side toward blade), and the blade bolt (Fig. 35).

**IMPORTANT: The curved part of the blade must be pointing toward the inside of the mower to assure proper cutting.**

2. Tighten the blade bolt to 45–60 ft-lb (61–81 Nm).

## Removing the Mower

1. Park the machine on a level surface, disengage the blade control (PTO), set the parking brake, and turn the ignition key to "OFF" to stop the engine.
2. Remove the key from the ignition switch and pull the wire off the spark plug.
3. Move the height-of-cut lever (deck lift) into the "D" notch.
4. Remove the height-of-cut lift assist spring from the retaining bolt (Fig. 38), using the spring tool provided with the machine. The spring is between the frame and the right rear wheel.

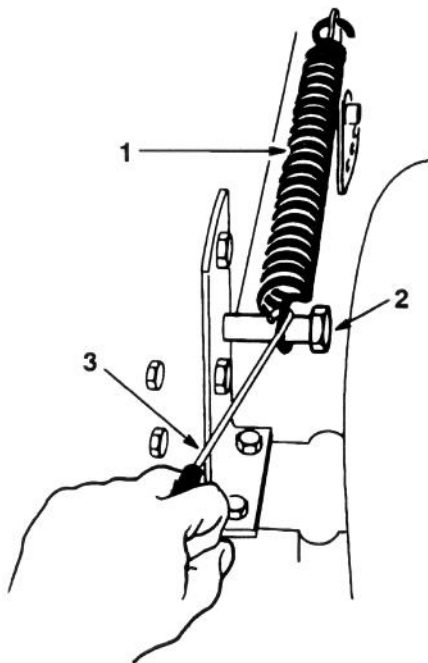

Figure 38

- |           |                |
|-----------|----------------|
| 1. Spring | 3. Spring tool |
| 2. Bolt   |                |

### CAUTION

#### POTENTIAL HAZARD

- The height-of-cut lever (deck lift) is spring-tensioned.

#### WHAT CAN HAPPEN

- When the mower is being removed, this spring-loaded mechanism could suddenly release and injure you or someone else.

#### HOW TO AVOID THE HAZARD

- Move the height-of-cut lever (deck lift) to the "D" position and remove the height-of-cut lift assist spring to release the spring tension.

5. Move the height-of-cut lever (deck lift) into the "A" notch.
6. Unhook the blade control (PTO) cable from the roller guides and idler arm on the right side of the mower (Fig. 39). Move the cable out of the way so it cannot get caught on the mower.

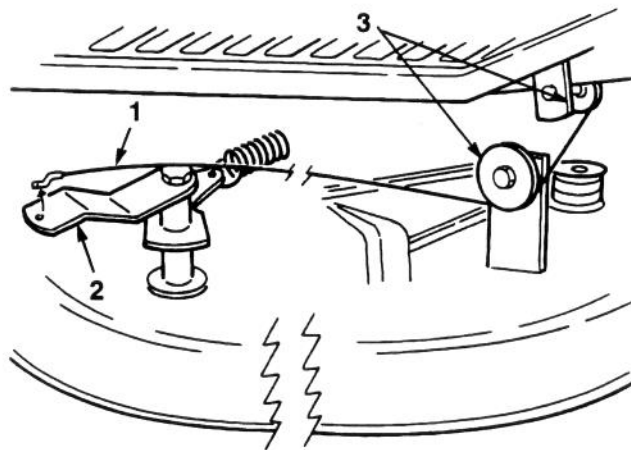

Figure 39

- |                        |                  |
|------------------------|------------------|
| 1. Blade control cable | 3. Roller guides |
| 2. Idler arm           |                  |

- Remove the bolts and lock nuts and pull the two mower pivot mount brackets down from the front axle (Fig. 40).

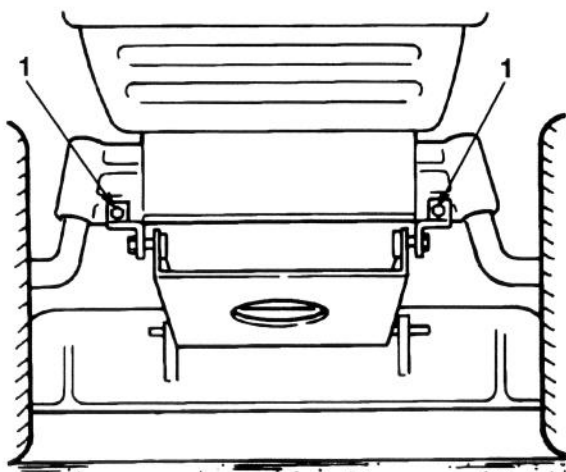

Figure 40

- Pivot mount brackets

- Remove the hair pin cotter and washer at the top of the mower leveling bracket (Fig. 41). Now slide the bracket off the mounting pin. Repeat this step on the opposite side of the mower.

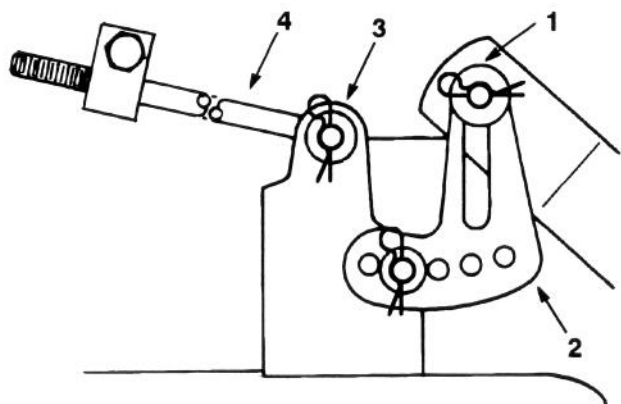

Figure 41

- |                               |                               |
|-------------------------------|-------------------------------|
| 1. Hair pin cotter and washer | 3. Hair pin cotter and washer |
| 2. Leveling bracket           | 4. Long rod                   |

- Remove the hair pin cotter and washer from the end of the long rod (Fig. 41). Now slide the rod out of the mower mount. Repeat this step on the opposite side of the mower.

**IMPORTANT: Tape or tie the long rods against the chassis to protect them from damage when you remove the mower.**

- Remove the mower belt from the lower engine pulley (Fig. 42). If you are careful, you can flex the belt guide(s) just far enough away from the pulley to remove the belt. If it is too difficult to remove the belt, loosen the bolts and nuts securing the belt guides.

**IMPORTANT: Do not bend the belt guide(s) away from the pulley because the belt will not operate properly when the mower is installed later.**

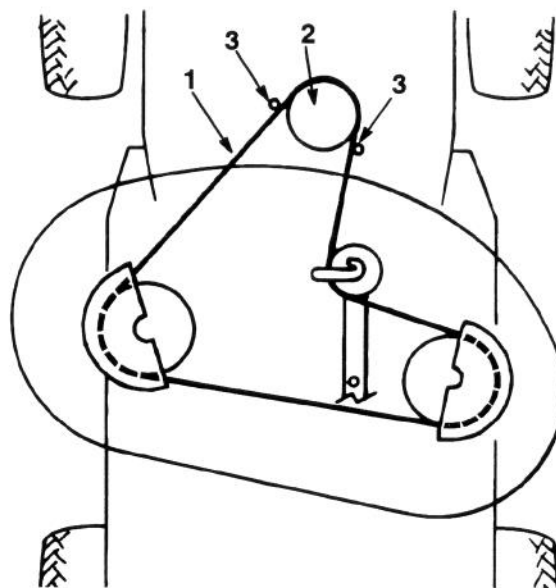

Figure 42

Top View

- |                  |                |
|------------------|----------------|
| 1. Mower belt    | 3. Belt guides |
| 2. Engine pulley |                |

- Turn the front wheels fully to the left. Slide the mower out to the right to complete removal.

## Installing the Mower

1. Park the machine on a level surface, disengage the blade control (PTO), set the parking brake, and turn the ignition key to "OFF" to stop the engine.
2. Remove the key from the ignition switch and pull the wire off the spark plug.
3. Turn the front wheels fully to the left. Slide the mower under the chassis from the right side.
4. Install mower belt onto the lower engine pulley (Fig. 42). If you are careful, you can flex the belt guide(s) just far enough away from the pulley to install the belt. If it is too difficult to install the belt, loosen the bolts and nuts securing the belt guides. If it is too difficult to install the belt, loosen the bolts and nuts securing the belt guides.

**IMPORTANT: Do not bend the belt guides away from the pulley. There must be 1/8" (3.175 mm) between the belt guide and the edge of the pulley to keep the belt on the pulley during operation. If the space is more than 1/8" (3.175 mm), adjust the belt guide(s) and tighten them securely. The belt guide must not contact the pulley.**

5. Install the mower pivot mount brackets to the front axle with bolts and lock nuts (Fig. 43).

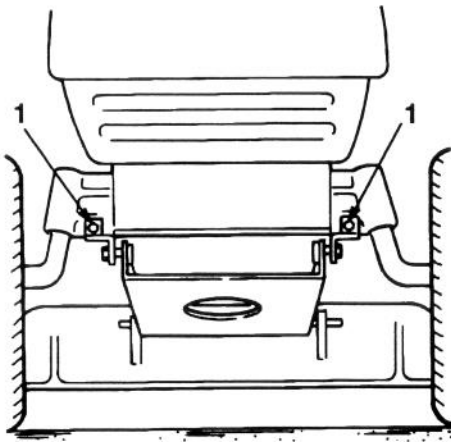

Figure 43

1. Pivot mount brackets

6. Move the height-of-cut lever (deck lift) into the "A" notch.
7. Slide the end of the long rod through the hole in the mower mount (Fig. 44). Install the washer and hair pin cotter to secure the rod in place. Repeat this step on the opposite side of the mower.
8. Mount the slotted mower leveling bracket onto the pin on the height-of-cut arm (Fig. 44). Install the washer and hair pin cotter to secure the mower. Repeat this step on the opposite side of the mower.

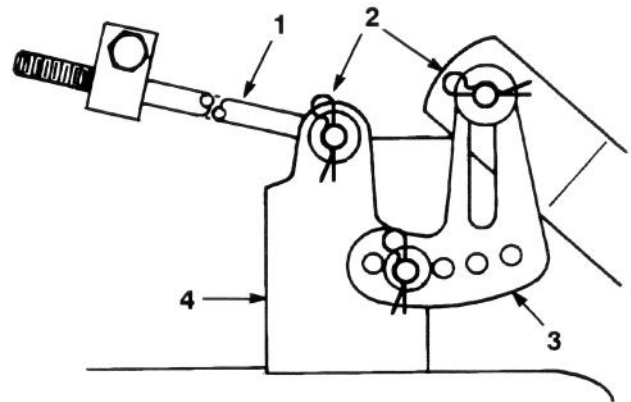

Figure 44

1. Rod
2. Hair pin cotter and washer
3. Leveling bracket
4. Mower mount

9. Loop blade control cable around the two roller guides and hook the end into the hole in the idler arm on the mower (Fig. 45).

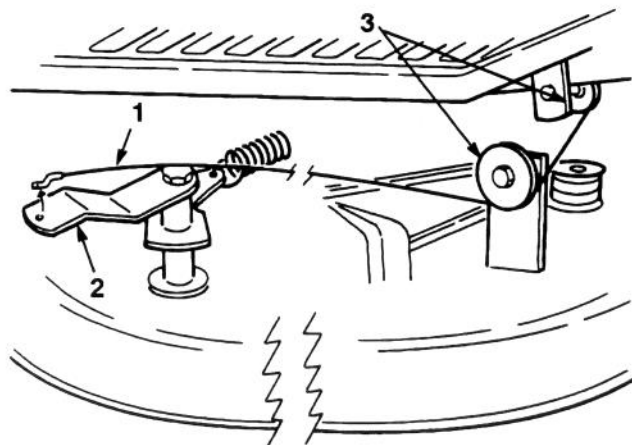

Figure 45

- |                        |                  |
|------------------------|------------------|
| 1. Blade control cable | 3. Roller guides |
| 2. Idler arm           |                  |

10. Move the height-of-cut lever (deck lift) into the "D" notch to make it easier to install the height-of-cut lift assist spring.

11. Hook the height-of-cut lift assist spring onto the retaining bolt (Fig. 46), using the spring tool provided with the machine.

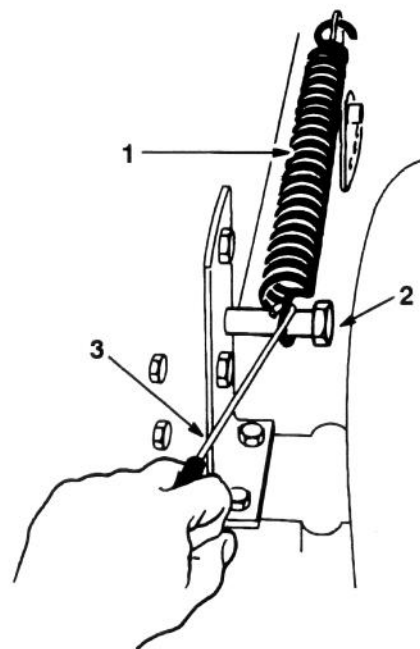

Figure 46

- |           |                |
|-----------|----------------|
| 1. Spring | 3. Spring tool |
| 2. Bolt   |                |

12. Check side-to-side blade level; refer to Side-to-Side Mower Leveling, page 39.

## Blade Drive Belt

### Removing the Blade Drive Belt

1. Remove the mower; refer to Removing the Mower, page 34.
2. Remove the pulley cover mounting screws and pulley covers from both blade pulleys (Fig. 47).
3. Loosen, but do not remove the bolt and nut securing the idler pulley and belt guide (Fig. 47).
4. Remove the belt from the pulleys.

### Installing the Blade Drive Belt

1. Install the new belt around the blade pulleys and under the belt guide on the idler pulley.
2. Position the idler pulley belt guide so it points toward the left,  $90^\circ$  to the idler arm (Fig. 47). Tighten the mounting bolt and lock nut securing the idler pulley and belt guide.
3. Install the left and right pulley covers with the mounting screws (Fig. 47).
4. Install the mower; refer to Installing the Mower, page 36.

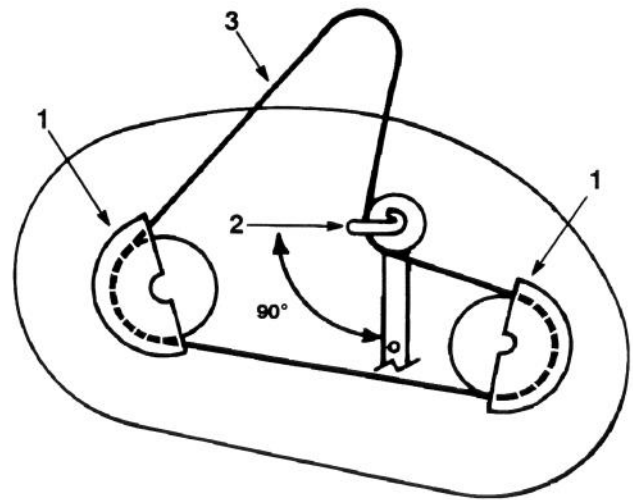

**Figure 47**

Top View

1. Pulley cover
  2. Idler pulley belt guide position
  3. Mower belt
-

## Side-to-Side Mower Leveling

The mower blades must be level from side to side. Check the side-to-side level any time you install the mower or when you see an uneven cut on your lawn. Before you level the mower, set the air pressure in the front and rear tires to 12 psi (.85 kPa).

1. Park the machine on a level surface, disengage the blade control (PTO), set the parking brake, and turn the ignition key to "OFF" to stop the engine.
2. Remove the key from the ignition switch and pull the wire off the spark plug.
3. Move the height-of-cut lever (deck lift) into the "C" notch.
4. Carefully rotate blade(s) side to side (Fig. 48). Measure between the outside cutting edges and the flat surface (Fig. 48). If both measurements are not within 3/16" (4.762mm), an adjustment is required; refer to steps 5 and 6.

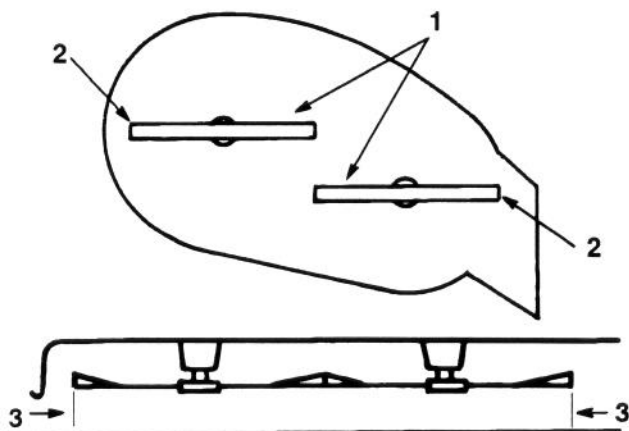

**Figure 48**

- |                          |                 |
|--------------------------|-----------------|
| 1. Blades side to side   | 3. Measure here |
| 2. Outside cutting edges |                 |

5. Remove the hair pin cotter and washer from the leveling bracket (Fig. 49). To level the blade(s), reposition the leveling bracket in a different hole and install the washer and hair pin cotter. (Fig. 49). A front hole lowers the blade height and a rear hole raises its height. Repeat this procedure on the opposite side.

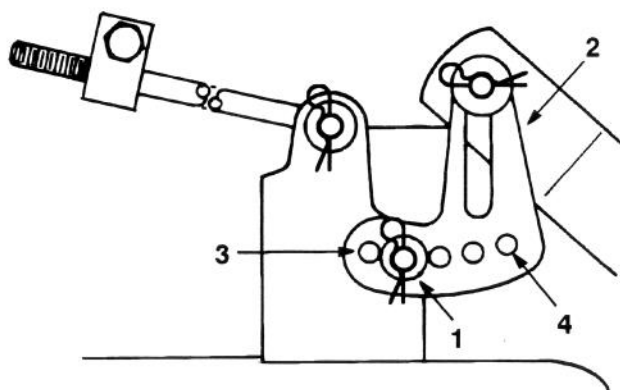

**Figure 49**

- |                               |               |
|-------------------------------|---------------|
| 1. Hair pin cotter and washer | 3. Front hole |
| 2. Leveling bracket           | 4. Rear hole  |
6. Now check the front-to-rear blade slope; refer to Front-to-Rear Blade Slope, page 40.

## Front-to-Rear Blade Slope

Check the front-to-rear blade slope any time you install the mower. Before you check the slope, set the air pressure in the front and rear tires to 12 psi (.85 kPa). If the front of the mower is more than 5/8" (15.875 mm) lower than the rear of the mower, adjust the blade slope using the following instructions:

1. Park the machine on a level surface, disengage the blade control (PTO), set the parking brake, and turn the ignition key to "OFF" to stop the engine.
2. Remove the key from the ignition switch and pull the wire off the spark plug.
3. Check and adjust side-to-side blade level if you have not checked the setting; refer to Side-to-Side Mower Leveling, page 39.
4. Move the height-of-cut lever (deck lift) into the "C" notch.
5. Check the front to rear slope by measuring between the bottom of the mower (front center and rear center) and the flat surface (Fig. 50). If the front of the mower is more than 5/8" (15.875 mm) lower than the rear of the mower, an adjustment is required; refer to steps 6, 7, 8 and 9.

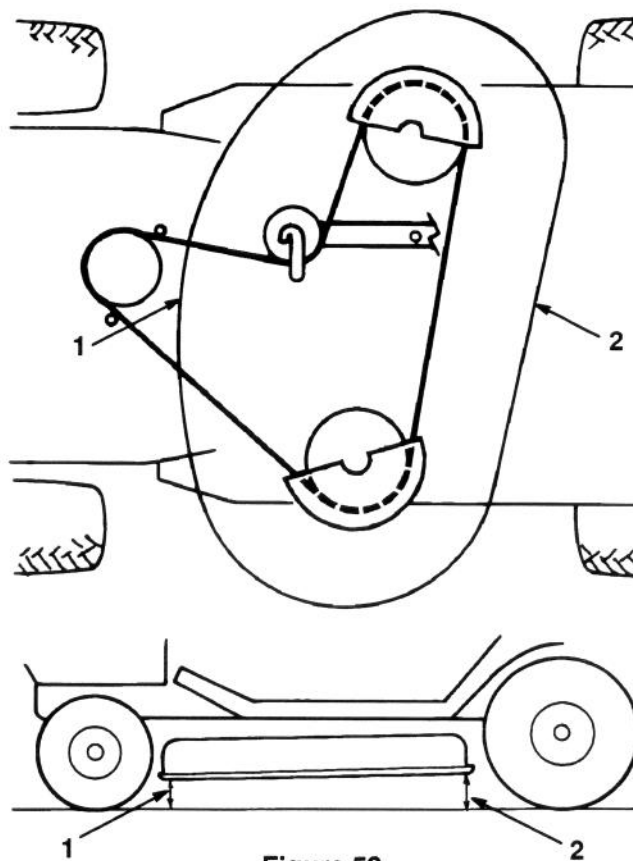

**Figure 50**

1. Measure front center      2. Measure rear center

6. Measure the length of the rod extending out the front of the adjusting block on the sides of the chassis (Fig. 51). If the rod length is not 5/8" (15.875 mm), remove the hair pin cotter and washer from the end of the rod (Fig. 51), and turn the rod until the 5/8" (15.875 mm) dimension is obtained. Then install the end of the rod into the hole in the mower mount and secure in place with washer and hair pin cotter. Repeat this procedure on the opposite side of the mower.

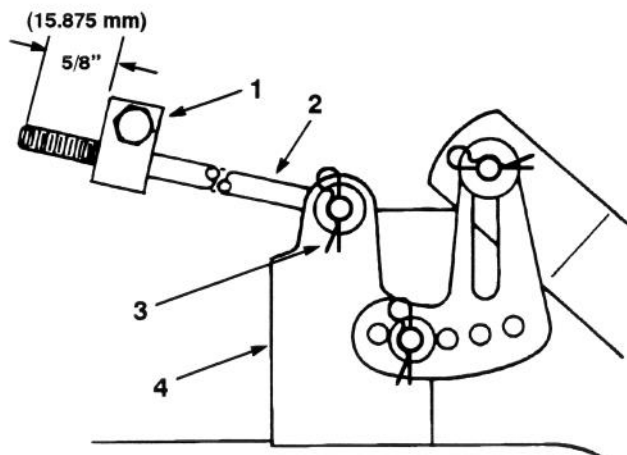

Figure 51

- |                    |                               |
|--------------------|-------------------------------|
| 1. Adjusting block | 3. Hair pin cotter and washer |
| 2. Long rod        | 4. Mower mount                |

7. Check the front-to-rear slope again. If the front of the mower is more than  $5/8$ " (15.875 mm) lower than the rear of the mower, proceed to step 8 for adjusting instructions. Otherwise, recheck the side-to-side level to assure it did not change.
8. Raise or lower the front of the mower by adjusting the length of the long rod and reinstalling it in the mower mount with the washer and hair pin cotter (Fig. 51). Adjust one side, then the other. After adjusting both rods, check the front-to-rear slope again. Continue to adjust the rods one turn at a time until the front of the mower is  $1/8$ " to  $3/8$ " (3.175 mm to 9.525 mm) lower than the rear of the mower.

**Note:** To raise the front of the mower, lengthen the rod by turning it counterclockwise. To lower the front of the mower, shorten the rod by turning it clockwise.

9. Measure the length of both rods extending out the front of the adjusting blocks on both sides of the chassis. If the rod lengths are not the same, remove the hair pin cotter and washer from the end of the loose rod and adjust it until both rods extend out the same length.

10. When front-to-rear slope is correct, recheck the side-to-side level of the mower; refer to Side-to-Side Mower Leveling, page 39.
11. Push the wire onto the spark plug.

## Storage

1. Clean dirt and chaff from the outside of the engine's cylinder head fins and blower housing. Also remove grass clippings, dirt, and grime from the external parts of the entire machine, especially the engine, shrouding, and the top of the mower.

**IMPORTANT: You can wash the machine with mild detergent and water. Do not pressure wash the machine. Avoid excessive use of water, especially near the control panel, lights, engine, and the battery.**

2. Scrape heavy buildup of grass and dirt from the underside of the mower. Then wash the mower with a garden hose.
3. Check the condition of the blade(s); refer to Cutting Blade, page 32.
4. Check the condition of the blade drive belt.
5. Check the brake; refer to Brake, page 19.
6. Service the air cleaner; refer to Air Cleaner, page 28.
7. Grease the chassis; refer to Greasing and Lubrication, page 18.
8. Change the crankcase oil; refer to Engine Oil, page 30.
9. Remove the spark plug and check its condition; refer to Spark Plug, page 24. With the spark plug removed from the engine, pour two tablespoons of engine oil into the spark plug hole. Now use the electric starter to crank the engine and distribute the oil inside the cylinder. Install the spark plug and tighten it to 15 ft-lb (20.4 Nm). Do not install the wire on the spark plug.
10. Remove the battery from the chassis, check the electrolyte level, and charge it fully; refer to Battery, page 22. Do not connect the battery cables to the battery posts during storage.

**IMPORTANT: The battery must be fully charged to prevent it from freezing and being damaged at temperatures below 32°F (0°C). A fully charged battery maintains its charge for about 50 days at temperatures lower than 40°F (4°C). If the temperatures will be above 40°F (4°C), check the water level in the battery and charge it every 30 days.**

11. Check the tire pressure; refer to Tire Pressure, page 19.
12. During long-term storage, either drain gasoline from the fuel tank (step A) or add a fuel additive to a full tank of gasoline (step B).
  - A. Drain gasoline from the fuel tank; refer to Fuel Tank, page 25. After fuel is drained, start the engine and let it idle until all gasoline is consumed and the engine stops. This eliminates gum-like buildup in the fuel system, which causes hard starting. Try to start the engine two more times to assure that no gasoline is in the fuel system.
  - B. Add the correct amount of Toro Stabilizer/Conditioner or an isopropyl-based stabilizer/conditioner to a full tank of gasoline.

**Note:** Stabilizer/conditioners normally preserve gasoline for six to eight months.
13. Check and tighten all bolts, nuts, and screws. Repair or replace any part that is damaged or defective.
14. Paint all scratched or bare metal surfaces. Paint is available from your Authorized Service Dealer.
15. Store the machine in a clean, dry garage or storage area. Remove the key from the ignition switch and keep it in a memorable place. Cover the machine to protect it and keep it clean.

# Troubleshooting

PROBLEM	POSSIBLE CAUSES	CORRECTIVE ACTION
Starter does not crank	<ol style="list-style-type: none"> <li>1. Blade control (PTO) is ENGAGED.</li> <li>2. Parking brake is not on.</li> <li>3. Battery is dead.</li> <li>4. Electrical connections are corroded or loose.</li> <li>5. Fuse is blown.</li> <li>6. Relay or switch is defective.</li> </ol>	<ol style="list-style-type: none"> <li>1. Move blade control (PTO) to DISENGAGED.</li> <li>2. Set parking brake.</li> <li>3. Charge the battery.</li> <li>4. Check electrical connections for good contact.</li> <li>5. Replace fuse.</li> <li>6. Contact Authorized Service Dealer.</li> </ol>
Engine will not start, starts hard, or fails to keep running.	<ol style="list-style-type: none"> <li>1. Operator is not seated.</li> <li>2. Fuel tank is empty.</li> <li>3. Air cleaner is dirty.</li> <li>4. Spark plug wire is loose or disconnected.</li> <li>5. Spark plug is pitted, fouled, or gap is incorrect.</li> <li>6. Choke is not closing.</li> <li>7. Dirt in fuel filter.</li> <li>8. Idle speed is too low or mixture is incorrect.</li> <li>9. Dirt, water, or stale fuel is in fuel system.</li> </ol>	<ol style="list-style-type: none"> <li>1. Sit on the seat.</li> <li>2. Fill fuel tank with gasoline.</li> <li>3. Clean or replace air cleaner element.</li> <li>4. Install wire on spark plug.</li> <li>5. Install new, correctly gapped spark plug.</li> <li>6. Adjust throttle cable.</li> <li>7. Replace fuel filter.</li> <li>8. Adjust carburetor idle speed and idle mixture.</li> <li>9. Contact Authorized Service Dealer.</li> </ol>
Engine loses power.	<ol style="list-style-type: none"> <li>1. Engine load is excessive.</li> <li>2. Air cleaner is dirty.</li> <li>3. Oil level in crankcase is low.</li> <li>4. Cooling fins and air passages under engine blower housing are plugged.</li> <li>5. Spark plug is pitted, fouled, or gap is incorrect.</li> <li>6. Vent hole in fuel cap is plugged.</li> <li>7. Dirt in fuel filter.</li> <li>8. Dirt, water, or stale fuel is in fuel system.</li> </ol>	<ol style="list-style-type: none"> <li>1. Reduce ground speed.</li> <li>2. Clean air cleaner element.</li> <li>3. Add oil to crankcase.</li> <li>4. Remove obstruction from cooling fins and air passages.</li> <li>5. Install new, correctly gapped spark plug.</li> <li>6. Clean or replace the fuel cap.</li> <li>7. Replace fuel filter.</li> <li>8. Contact Authorized Service Dealer.</li> </ol>

PROBLEM	POSSIBLE CAUSES	CORRECTIVE ACTION
Engine over heats.	<ol style="list-style-type: none"> <li>1. Engine load is excessive.</li> <li>2. Oil level in crankcase is low.</li> <li>3. Cooling fins and air passages under engine blower housing are plugged.</li> </ol>	<ol style="list-style-type: none"> <li>1. Reduce ground speed.</li> <li>2. Add oil to crankcase.</li> <li>3. Remove obstruction from cooling fins and air passages.</li> </ol>
Abnormal vibration.	<ol style="list-style-type: none"> <li>1. Cutting blade(s) is bent or unbalanced.</li> <li>2. Blade mounting bolt is loose.</li> <li>3. Engine mounting bolts are loose.</li> <li>4. Loose engine pulley, idler pulley, or blade pulley.</li> <li>5. Engine pulley is damaged.</li> </ol>	<ol style="list-style-type: none"> <li>1. Install new cutting blade(s).</li> <li>2. Tighten blade mounting bolt.</li> <li>3. Tighten engine mounting bolts.</li> <li>4. Tighten the appropriate pulley.</li> <li>5. Contact Authorized Service Dealer.</li> </ol>
Blade(s) does not rotate.	<ol style="list-style-type: none"> <li>1. Blade drive belt is worn, loose or broken.</li> <li>2. Blade drive belt is off pulley.</li> </ol>	<ol style="list-style-type: none"> <li>1. Install new blade drive belt.</li> <li>2. Install blade drive belt and check idler pulley and belt guides for correct position.</li> </ol>
Machine does not drive.	<ol style="list-style-type: none"> <li>1. Drive control wire in "PUSH" position.</li> <li>2. Traction belt is worn, loose or broken.</li> <li>3. Traction belt is off pulley.</li> </ol>	<ol style="list-style-type: none"> <li>1. Move drive control wire to "OPERATE" position.</li> <li>2. Contact Authorized Service Dealer.</li> <li>3. Contact Authorized Service Dealer.</li> </ol>
Uneven cutting height.	<ol style="list-style-type: none"> <li>1. Tire pressure is incorrect.</li> <li>2. Mower is not level.</li> <li>3. Underside of mower is dirty.</li> </ol>	<ol style="list-style-type: none"> <li>1. Set tire pressure.</li> <li>2. Level mower from side-to-side and front-to-rear.</li> <li>3. Clean the underside of the mower.</li> </ol>