



Count on it.

Parts Catalog

17in Curved-Shaft Gas Trimmer

Model No. 51958—Serial No. 314000001 and Up



Ordering Replacement Parts

To order replacement parts, please supply the part number, the quantity, and the description of each part desired.

Understanding Reference Numbers

Each identified part in an illustration has a reference number. The reference number for a part also appears in the parts list, along with other information about the part.

This catalog uses two special reference number formats, one to indicate parts in a service assembly and another to indicate the quantity of a given part in an illustration.

Service Assembly Reference Numbers

Parts in service assemblies have reference numbers in the form a:b. The a represents the reference number of the entire service assembly and the b represents a sequential number unique to each part within the service assembly.

For example, a wheel assembly might be identified by reference number 6, the tire by 6:1, the valve by 6:2, and the wheel by 6:3. When you order the assembly identified by reference number 6, you receive all parts identified by reference numbers 6:1, 6:2, and 6:3. However, you may also order any part individually. Reference numbers of this type appear in illustration and in parts lists.

Reference Numbers Indicating Quantity

In an illustration, if a reference number indicates more than one part, the reference number has the form nX y. The n represents the quantity of the part, the X is the multiplication symbol, and the y represents the reference number.

For example, in an illustration, the reference number 2X 37 means that two of the parts identified by reference number 37 are indicated.

List of Abbreviations

AR: as required

ASM: assembly

BBC: blade brake control

BHTF: button head thread forming

CARR: carriage

CCW: counter clockwise

CW: clockwise

DEG: degrees

DPA: Dual Point Adjustment

ECM: electronic control module

EXT: external

FH: flat head

GA: gauge

HD: heavy-duty

HF: hex flange

HH: hex head

HHF: hex head flange

HHFTF: hex head flange thread forming

HJ: hex jam

HLH: hex lag head

HOC: height-of-cut

HP: high pressure

HSBH: hex socket button head

HSFH: hex socket flat head

HSH: hex socket head

HWH: hex washer head

HWTF: hex washer head thread forming

HYD: hydraulic

LH: left hand

LP: low pressure

LPG: Liquefied Petroleum Gas

NI: nylon insert

NPTF: national pipe thread fine

PFH: phillips flat head

PPH: phillips pan head

PPHTF: phillips pan head thread forming

PRH: phillips round head

PTH: phillips truss head

PTO: power-take-off

RH: right hand

ROPS: roll-over protection system

RRB: rear roller brush

SFH: slotted fillister head

SHH: slotted hex head

SHWH: slotted hex washer head

SPH: slotted pan head

SQH: square head

SRH: slotted round head

STD: standard

TAP: self tapping

TTH: torx truss head

Contents

Trimmer Head, Shaft and Guard Assembly 4
Upper Shaft, Handle and Powerhead Assembly 6
Powerhead Assembly No. 308466016 8
Attachments and Accessories 10

Trimmer Head, Shaft and Guard Assembly

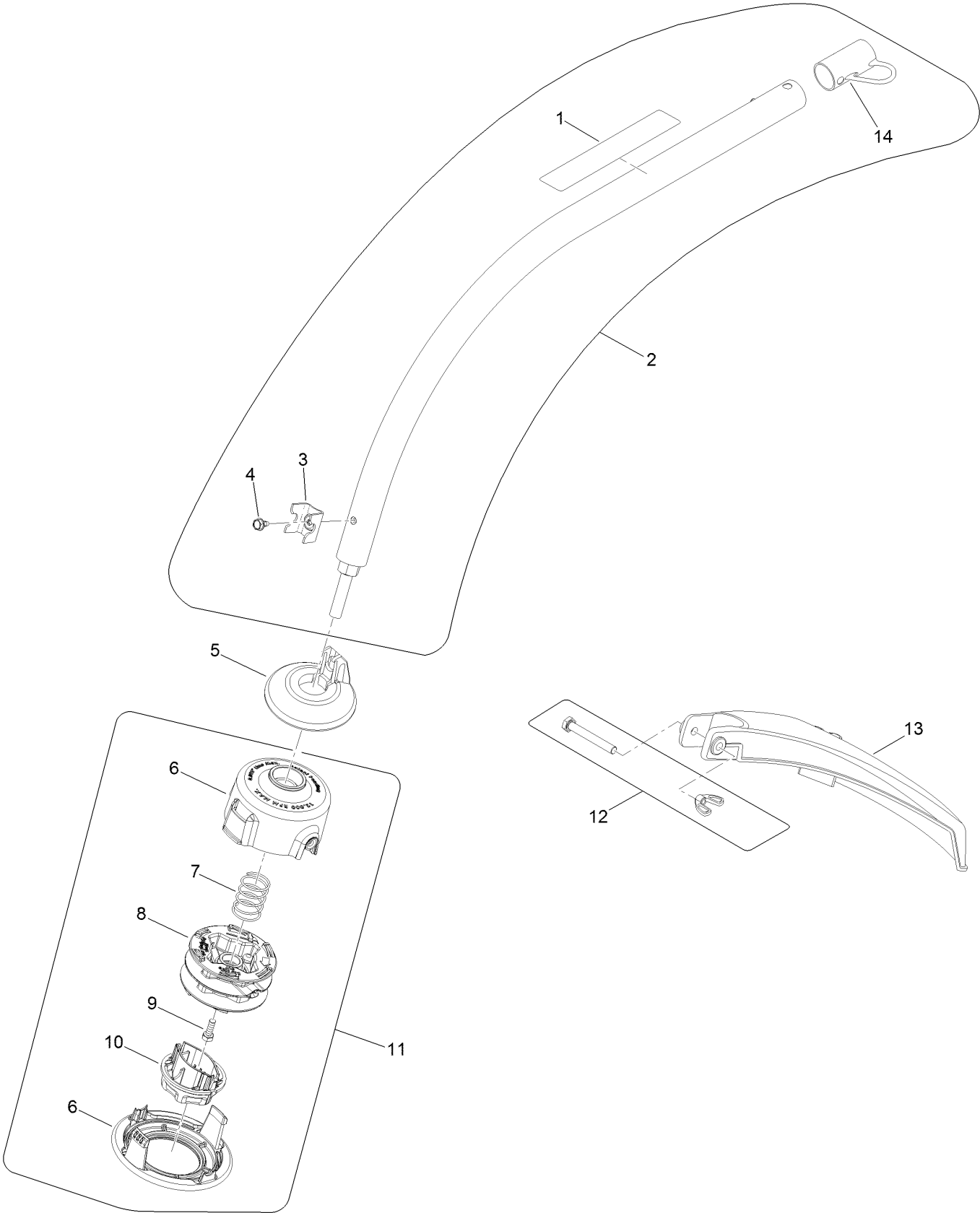

Trimmer Head, Shaft and Guard Assembly (continued)

<i>Ref.</i>	<i>Part Number</i>	<i>Qty.</i>	<i>Description</i>	<i>Ref.</i>	<i>Part Number</i>	<i>Qty.</i>	<i>Description</i>
1	940657032	1	Decal-Label, Warning	8	308924002	1	Spool
2	308841013	1	Curved Shaft ASM	9	660650001	1	Bolt
3	638001001	1	Clamp	10	518803003	1	Knob-Bump
4	660647001	1	Screw-HWH	11	309034001	1	Trimmer Head ASM
5	522702001	1	Shield-Grass	12	120650007	1	Grass Shield Hardware Kit
6	308827003	1	Housing-Stringhead	13	308052005	1	Guard-Trimmer
7	678749001	1	Spring-Compression	14	518019002	1	Cap-Hanger

Upper Shaft, Handle and Powerhead Assembly

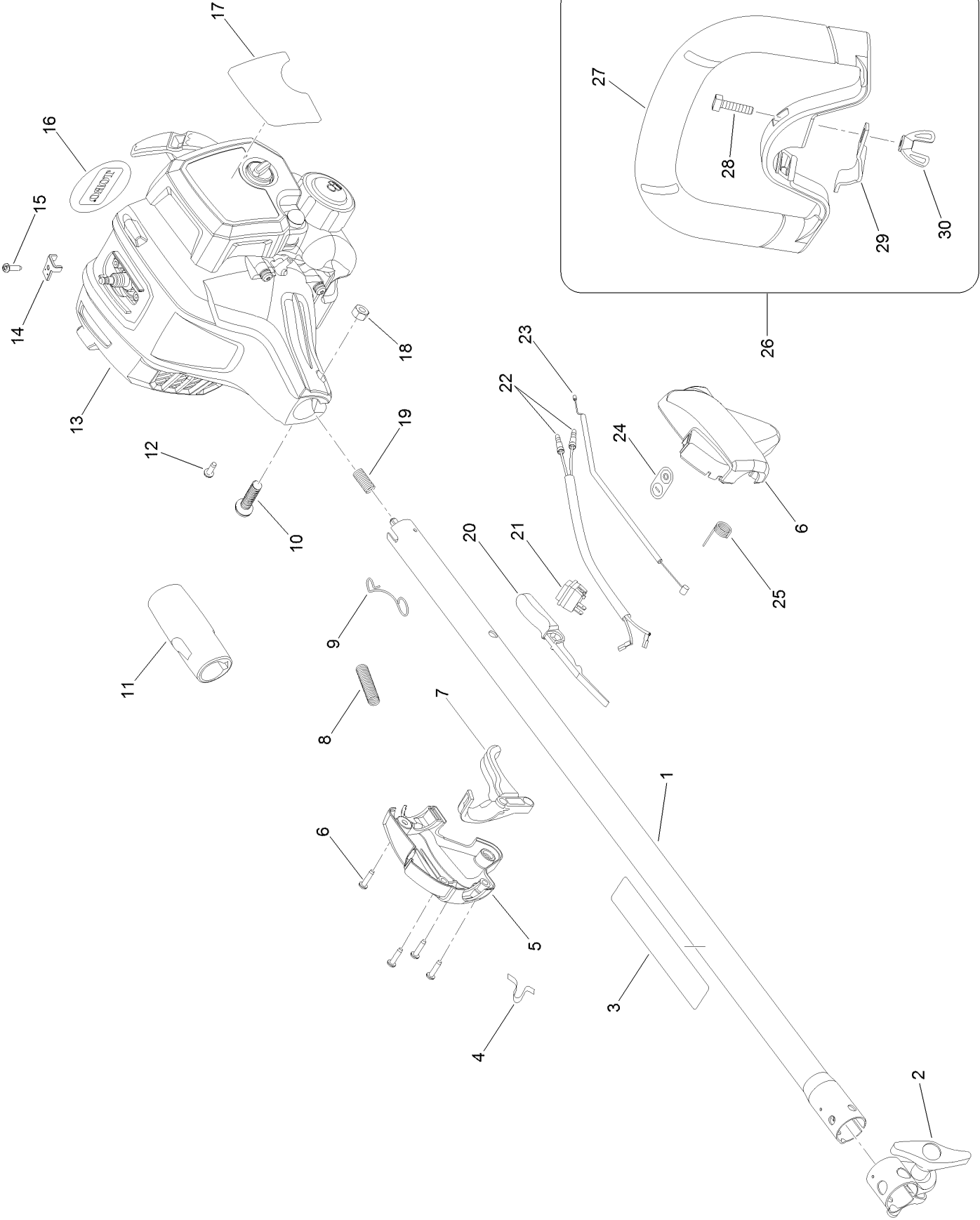

Upper Shaft, Handle and Powerhead Assembly (continued)

<i>Ref.</i>	<i>Part Number</i>	<i>Qty.</i>	<i>Description</i>	<i>Ref.</i>	<i>Part Number</i>	<i>Qty.</i>	<i>Description</i>
1	308159025	1	Upper Shaft ASM	16	940865001	1	Plate-Logo
2	308045014	1	Shaft Clamp ASM	17	940686148	1	Decal-Start
3	940657034	1	Label-Warning	18	678029002	1	Nut-Hex
4	638431001	1	Clip-Strap, Shoulder	19	678906001	1	Spring-Compression
5	308869003	1	Control Handle ASM	20	518695008	1	Trigger-Lock, Throttle
6	660563002	4	Screw	21	760700001	1	Switch-On/Stop
7	518696008	1	Trigger-Throttle	22	770670001	1	Harness-Wire
8	518210004	1	Tube-Corrugated	23	308225011	1	Cable-Throttle
9	678818001	1	Spring-Cable, Throttle	24	940864003	1	Label-On/Stop
10	T660697001	1	Screw	25	690694002	1	Spring-Trigger
11	570234009	1	Grip-Shaft, Upper	26	308056009	1	Handle ASM
12	660925011	1	Screw	27	526760001	1	Handle-Shaft, Upper
13	308466016	1	Powerhead ASM	28	660857001	1	Screw
14	638133001	1	Clamp-Cable, Throttle	29	639167001	1	Clamp-Handle, Upper Shaft
15	660734001	1	Screw	30	518949001	1	Nut-Wing

Powerhead Assembly No. 308466016

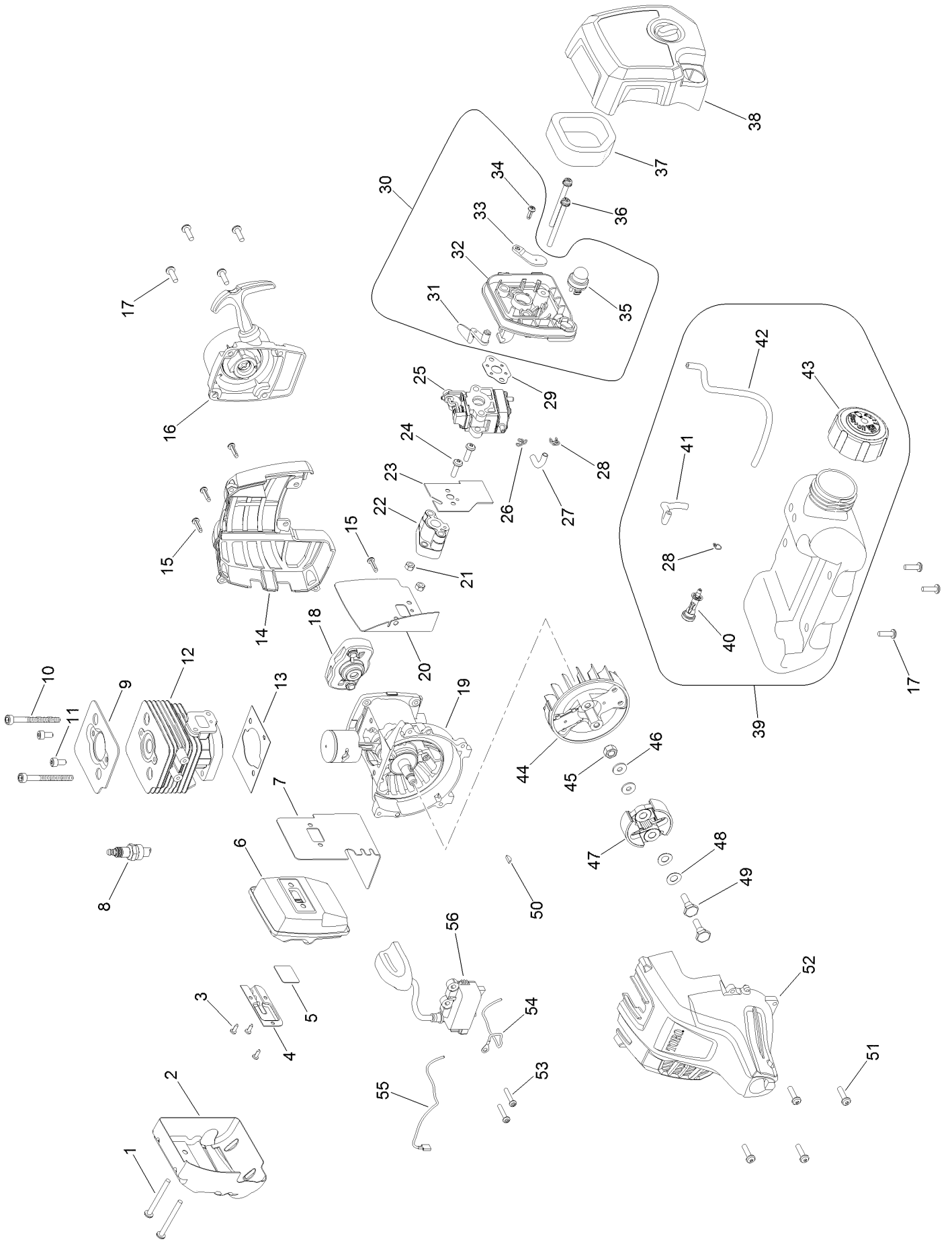

Powerhead Assembly No. 308466016 (continued)

<i>Ref.</i>	<i>Part Number</i>	<i>Qty.</i>	<i>Description</i>	<i>Ref.</i>	<i>Part Number</i>	<i>Qty.</i>	<i>Description</i>
1	660347001	2	Screw-Pan HD	29	900711003	1	Gasket-Carburetor
2	638027002	1	Shield-Heat	30	308478004	1	Filter Housing ASM
3	660870001	3	Screw-Pan HD	31	590458001	1	Lever-Choke
4	638267001	1	Cover-Trimmer	32	518130001	1	Plate-Carburetor
5	638268001	1	Screen	33	590946001	1	Plate-Choke
6	300748021	1	Muffler ASM	34	660345001	1	Screw-Pan HD
7	630002032	1	Gasket-Muffler	35	300780002	1	Primer ASM
8	870170001	1	Spark Plug	36	660346001	2	Screw-Pan HD
9	630002021	1	Plate-Cylinder	37	560873001	1	Element
10	660342001	2	Screw-Socket Head	38	308207006	1	Cover-Intake, Air
11	660351002	2	Screw-Pan Head, Torx	39	308675054	1	Fuel Tank ASM
12	640570016	1	Cylinder	40	310976001	1	Filter-Fuel
13	900709005	1	Gasket	41	570373010	1	Hose-Fuel
14	591644001	1	Housing-Engine, Rear	42	562967008	1	Hose-Fuel
15	660563001	4	Screw	43	310816005	1	Cap-Fuel
16	308430001	1	Recoil Starter ASM	44	640574002	1	Rotor
17	660351001	7	Screw-Pan HD	45	690689001	1	Nut-Rotor
18	308004001	1	Pulley ASM	46	690695001	2	Washer
19	300749010	1	Crankcase ASM	47	300756007	1	Clutch ASM
20	900711008	1	Gasket-Insulator	48	690696001	2	Washer-Curved
21	690840001	2	Nut	49	660353001	2	Screw-Clutch
22	518329001	1	Insulator-Dam, Heat	50	6690688001	1	Key-Woodruff
23	901697001	1	Gasket	51	660344001	4	Screw-Pan HD
24	660344003	2	Screw-Pan HD	52	300754031	1	Housing-Engine, Front
25	308480001	1	Carburetor ASM	53	660349001	2	Screw-Pan HD
26	690700001	1	Clip-Hose	54	290143002	1	Wire-Lead, Red
27	570373002	1	Line-Fuel, 45Mm	55	290143001	1	Wire-Lead, Black
28	690699001	2	Clip-Hose	56	290178020	1	Coil And Boot ASM

Attachments and Accessories

For 51958 17in Curved-Shaft Gas Trimmer

Product Name	Model/Part
Spark Arrestor Kit	000998216
High Altitude Kit	120900107

Notes:



Count on it.