

MODEL NO. 79351 - 3900001 & UP	INSTALLATION INSTRUCTIONS
WHEEL HORSE® 50 in. Mid-Mount Grader Blade - GT	

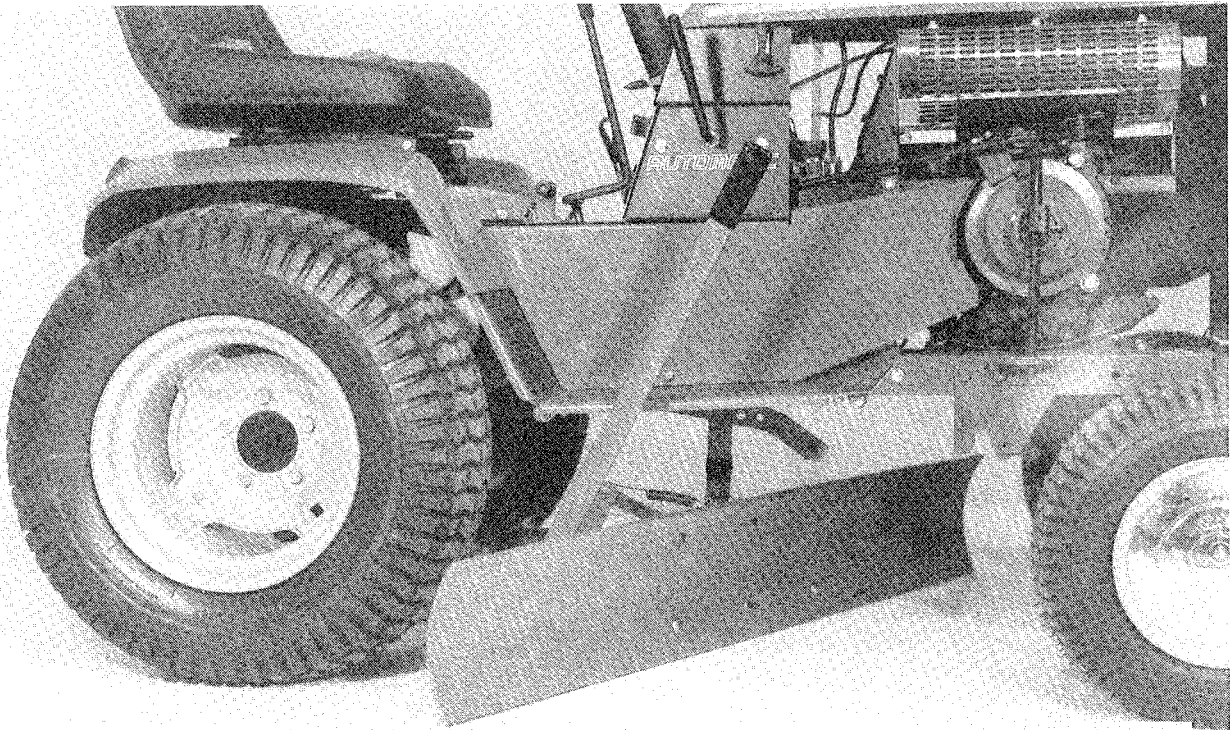

1779

TABLE OF CONTENTS

	<u>Page</u>		<u>Page</u>
MODEL AND SERIAL NUMBER	1	INSTALL BLADE	2-3
ASSEMBLE BLADE	1	Attach Mounting Bracket	2
Identify Parts	1	Attach Blade	2
Attach Blade to Frame Assembly	1	MAINTENANCE AND STORAGE	3
Install Blade Index Lever	1		
Attach Index Lever Return Spring	1		

SAFETY DECALS AND INSTRUCTIONS

Safety decals and instructions are easily visible to the operator and are located near any area of potential danger. Replace any decal that is damaged or lost.



Back of Blade
Part No. 92-1745

MODEL AND SERIAL NUMBER

A Model and Serial Number identifies your Toro Wheel Horse attachment. These numbers should always be referred to when consulting with your dealer or factory concerning service, replacement parts, or questions you may have. For your reference, record numbers from Model and Serial Number plate on your attachment.

MODEL _____
SERIAL NO. _____

ASSEMBLE BLADE (Figs. 1-5)

Identify Parts

Remove all parts from box and identify as shown in Fig. 1. Hardware items used during assembly are loosely installed in their approximate positions or are contained in the loose parts package.

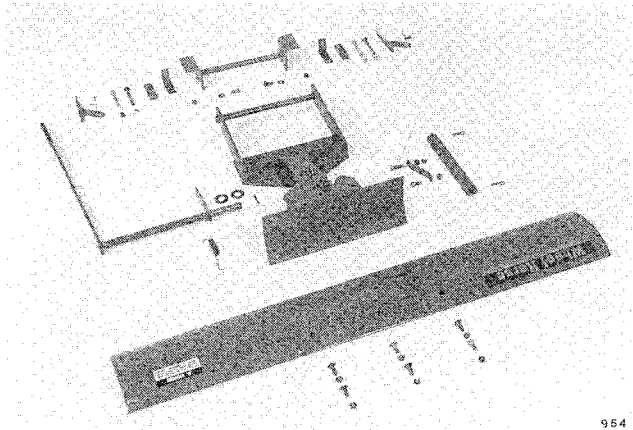

Fig. 1 Grader Blade Package

Attach Blade to Frame Assembly

Install blade on mounting frame using six 3/8-16 x 1 carriage bolts and elastic stop nuts (Fig.2).

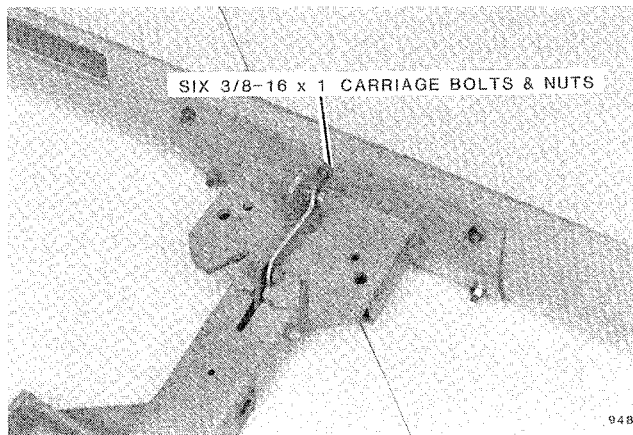

FIG. 2 Mount Blade to Frame Assembly

Install Blade Index Lever

Insert blade index lever through blade frame with 3/4" washers on both sides of frame. Secure with 1/8 x 1 1/4 cotter pin (Fig. 3).

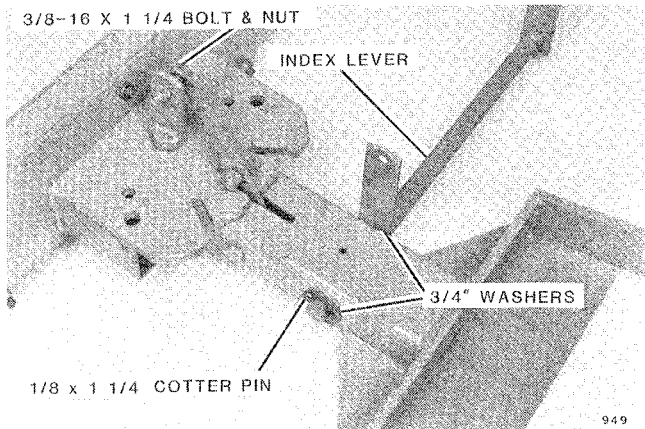

FIG. 3 Install Blade Index Lever

Remove 3/8-16 x 1 1/4 bolt (Fig. 3) securing latch link to pivot bolt. Reattach latch link to index lever with same nut and bolt (Fig. 4). Tighten bolts securing latch link and loosen 1/4 turn.

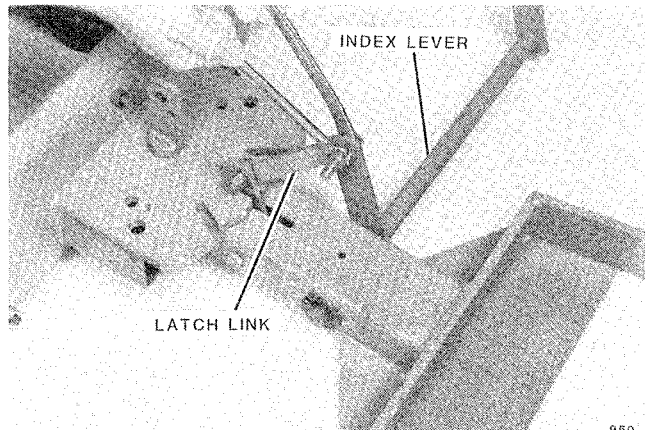

FIG. 4 Attach Latch Link to Lift Handle

Attach Index Lever Return Spring

Thread locking jam nut onto end of 3/8-16 x 1 1/4 bolt and install index return spring as shown in Fig. 5.

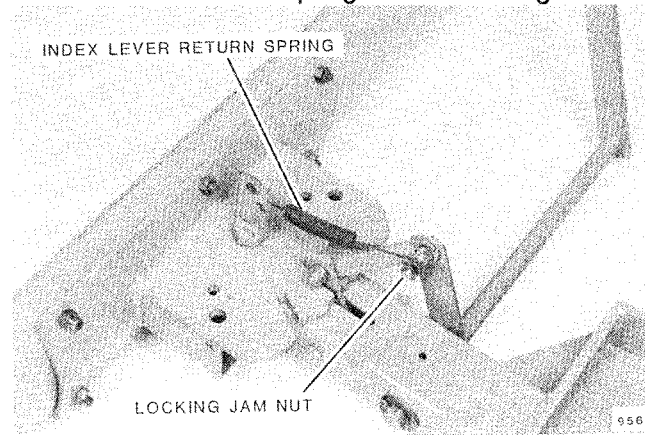

FIG. 5 Install Index Lever Return Spring

INSTALL BLADE (Figs. 6-11)

Attach Mounting Bracket

Locate rear mounting bracket, two latching plates, two 3/8-16 x 1 carriage bolts, two 3/8 washers, two 3/8-16 E.S. nuts, two 1/4 x 1/2 clevis pins, four small hairpin cotters, two links, two angle spacers, four 3/8-16 x 3 1/2 carriage bolts, four 3/8-16 E.S. nuts and a lift link.

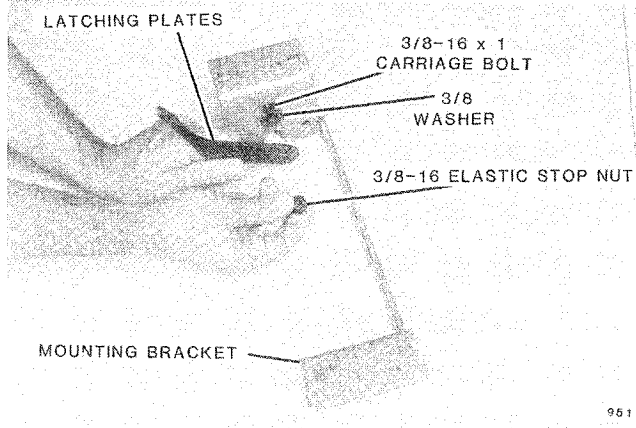

Fig. 6 Attach Latching Plates to Mounting Bracket

Attach two latching plates to rear mounting bracket using two 3/8-16 x 1 carriage bolts, washers and nuts. Washers are used between mounting bracket and latching plate. Latching plates are installed on inside of mounting bracket (Fig. 6). Tighten bolts so latching plates will move with a small amount of force.

Install two metal links on rear mounting bracket using two 3/8-16 x 3 1/2 carriage bolts and nuts. Install bolts in holes farthest from latching plates (Fig. 7). Finger tighten nuts.

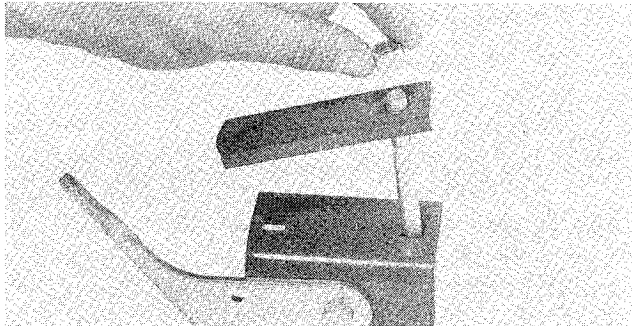

FIG. 7 Install Metal Links

From rear of tractor, install rear mounting bracket assembly to tractor's rear axle housings. This is done by placing bracket assembly under tractor's transmission so that latch plate ends face rearward. Turn metal links toward front of tractor (Fig. 8).

Raise rear bracket so that bracket touches bottom of axle housing (Fig. 9). Turn metal links rearward so they

hold bracket in place. Install and hand tighten two 3/8-16 x 3 1/2 carriage bolts and nuts in rear mounting holes of bracket and links.

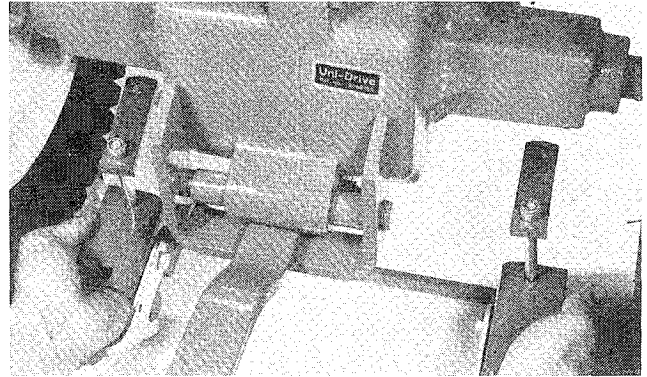

FIG. 8 Attach Rear Mounting Bracket

NOTE: On 8-Speed tractors, use angle spacers to take out undue slack between hitch and rear axle. Install angle spacers between metal links and tractor axle housings (Fig. 9).

Center rear hitch evenly between rear wheels. Tighten nuts evenly to insure maximum strength.

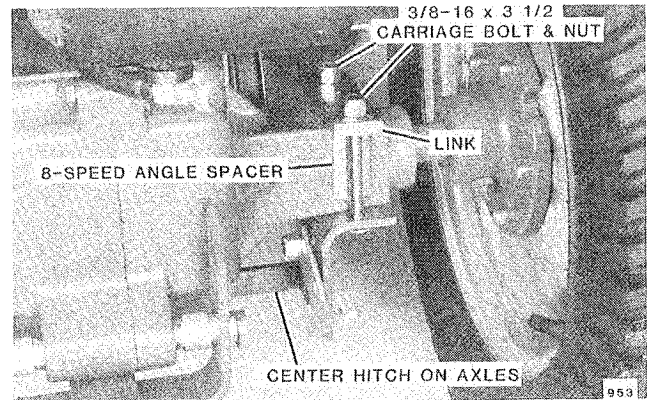

FIG. 9 Install Carriage Bolts & Nuts

Attach Blade

Slide blade frame under tractor so that rear mounting shaft is directly under rear bracket assembly. Open both sides of mounting bracket by lifting latching plates. Raise rear of blade frame so that mounting shaft slips into mounting bracket slots. Close bracket by pushing down on both latching plate (Fig 10). Install two 1/4 x 1/2 clevis pins and hairpin cotters in latching plates and mounting bracket.

Lower tractor's attachment lift and install as shown in Figure 11. Retain with two hairpin cotters.

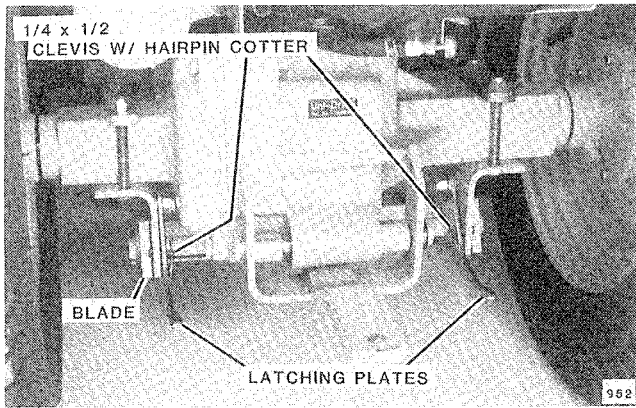

FIG. 10. Attach Blade Frame to Mounting Bracket

⚠ CAUTION ⚠

Avoid hitting solid objects with the blade, as this could result in damage to the blade and injury to the operator. Always travel at a safe, slow speed.

Blade can be indexed to 3 positions (30° left, center and 30° right) by pulling index lever rearward and then swinging blade to desired position. Spring loaded index lever will return to latched position when released.

Regulate blade height with tractor's attachment lift.

MAINTENANCE AND STORAGE

Blade should be cleaned after each use. Wash blade using a garden hose. A mild automotive detergent may be used to remove stubborn dirt.

Exposed bare metal surfaces should be coated with oil or grease to prevent rust until permanent repairs can be made. Aerosol cans of "Toro Wheel Horse Red" touch up paint are available through your Authorized Toro Wheel Horse Dealer.

Before operation, make sure all bolts are tight. A light grade of machine oil should be applied to moving parts of linkage and pivot points after every 10 hours of use.

Store blade in a clean dry place or protect it with a weather-proof cover if stored outdoors.

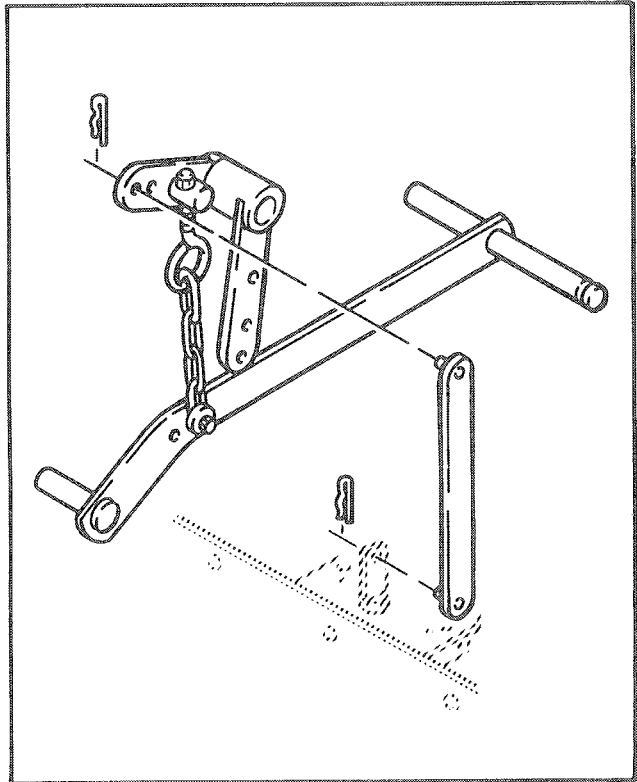

Fig.11 Attach Lift Link



Consumer Products

THE TORO TOTAL COVERAGE GUARANTEE

A Full Two-Year Warranty (Limited Warranty for Commercial Use)

What Is Covered By This Express Warranty?

The Toro Company promises to repair any TORO Product used for residential purposes if defective in materials or workmanship for a period of two years from the date of purchase. The cost of parts and labor are included, but the customer pays the transportation costs.

Transportation within a 15 mile radius of the servicing dealer is covered under this warranty for two-stage snowthrowers, walk behind debris equipment and all TORO Wheel Horse riding products. Walk power mowers, single stage snowthrowers, and other products not specifically covered, are excluded from the transportation coverage provided by this warranty.

What Products Are Covered By This Warranty?

This warranty applies to all gasoline powered Consumer Products (including TORO Wheel Horse riding products). ProLine riding products, wide area walk behind mowers and 21" Commercial mowers without blade stop controls are covered by separate warranty statements.

How About Commercial Use?

TORO Consumer Products used for commercial, institutional or rental use are covered by a limited warranty for the following time periods from the date of purchase:

Products	Warranty Period
• Garden Tractors	
Chassis	1 year limited warranty
Engine	2 year limited warranty
• 21" Commercial Duty Walk Mower with blade stop controls	1 year limited warranty
• Lawn Tractors, Yard Tractors, Rear Engine Riders, 3.0 and 3.5 HP Edgers, Straight Shaft Trimmers, and Backpack Blowers	90 day limited warranty
• All Others	45 day limited warranty

How Do You Get Warranty Service?

Should you feel your TORO product contains a defect in material or workmanship, contact the dealer who sold you the product or any Authorized TORO Service Dealer or TORO Master Service Dealer. The Yellow Pages of your telephone directory is a good reference source. The dealer will either arrange service at his/her dealership or recommend another Authorized Service Dealer who may be more convenient. You may need proof of purchase (copy of registration card, sales receipt, etc.) for warranty validation.

If for any reason you are dissatisfied with the Service Dealer's analysis of the defect in materials or workmanship or if you need a referral to a TORO Service Dealer, please feel free to contact us at the following address:

Toro Customer Service Department
8111 Lyndale Avenue South
Bloomington, MN 55420-1196
612-888-8801

What Must You Do To Keep The Warranty In Effect?

You must maintain your TORO Product by following the maintenance procedures described in the operator's manual. Such routine maintenance, whether performed by a dealer or by you, is at your expense.

What Does This Warranty Not Cover? and

How Does Your State Law Relate To This Warranty?

There is no other express warranty except the TORO Starting Guarantee on GTS Engines. This express warranty does not cover:

- Cost of regular maintenance service or parts, such as filters, fuel, lubricants, tune-up parts, blade sharpening, brake and clutch adjustments.
- Any product or part which has been altered or misused or required replacement or repair due to normal wear, accidents, or lack of proper maintenance.
- Repairs necessary due to improper fuel, contaminants in the fuel system, or failure to properly prepare the fuel system prior to any period of non-use over three months.
- Pickup and delivery charges for distances beyond a 15 mile radius from an Authorized TORO Service Dealer (covered products only).

All repairs covered by this warranty must be performed by an Authorized TORO Service Dealer using Toro approved replacement parts.

Repair by an Authorized TORO Service Dealer is your sole remedy under this warranty.

The Toro Company is not liable for indirect, incidental or consequential damages in connection with the use of the TORO Products covered by this warranty, including any cost or expense of providing substitute equipment or service during reasonable periods of malfunction or non-use pending completion of repairs under this warranty. Some states do not allow exclusions of incidental or consequential damages, so the above exclusion may not apply to you.

This warranty gives you specific legal rights, and you may also have other rights which vary from state to state.

COUNTRIES OTHER THAN THE UNITED STATES OR CANADA

Customers who have purchased TORO products exported from the United States or Canada should contact their TORO Distributor (Dealer) to obtain guarantee policies for your country, province, or state. If for any reason you are dissatisfied with your Distributor's service or have difficulty obtaining guarantee information, contact the TORO importer. If all other remedies fail, you may contact us at The Toro Company.