

Model No. 79361-3900001 & UP

**INSTALLATION
INSTRUCTIONS**

WHEEL HORSE®
44" (112 cm) Snowthrower



CONTENTS

	Page		Page
MODEL AND SERIAL NUMBER	2	REMOVAL AND INSTALLATION (CONT'D)	
MOUNTING INFORMATION	2-5	INSTALLATION	6
ASSEMBLE SNOWTHROWER	2-3	OPERATION AND ADJUSTMENT	7-8
ATTACH SNOWTHROWER TO TRACTOR	3-5	MAINTENANCE AND STORAGE	8-9
SNOWTHROWER REMOVAL AND INSTALLATION	5-6	DRIVE BELT REPLACEMENT	9
REMOVAL	5-6		

SAFETY DECALS AND INSTRUCTIONS

Safety decals and instructions are easily visible to the operator and are located near any area of potential danger. Replace any decal that is damaged or lost.

 WARNING

LOSS OF TRACTION AND STABILITY MAY RESULT IN SERIOUS INJURY WHEN SNOWTHROWER IS IN A RAISED POSITION WITHOUT ADDITIONAL COUNTER WEIGHT.

 SEE OPERATOR'S MANUAL FOR COMPLETE INSTRUCTIONS.

TRACTORS MUST BE EQUIPPED WITH 100 LBS. REAR WHEEL WEIGHT WITH THIS ATTACHMENT INSTALLED.

86-5100

Left Back of Housing
Part no. 86-5100

 WARNING

**SPRING LOADED MECHANISM
NEVER DISASSEMBLE BEFORE
READING OPERATOR'S MANUAL.**

85-7480

Left Frame
Part No. 85-7480

 DANGER



AVOID INJURY!
SHUT OFF ENGINE AND BE SURE
ALL PARTS HAVE STOPPED BEFORE
UNCLOGGING DISCHARGE CHUTE.

63-3740

Right Back of Housing
Part No. 63-3740

 DANGER



AVOID INJURY FROM ROTATING
AUGER. KEEP HANDS, FEET AND
CLOTHING AWAY.

Left Back of Housing
Part No. 63-2380

 WARNING

**SPRING LOADED MECHANISM
NEVER DISASSEMBLE BEFORE READING OPERATOR'S MANUAL.**

85-7490

Left and Right Lift Linkage
Part No. 85-7490(2)

MODEL AND SERIAL NUMBER

A Model and Serial Number identifies your Toro Wheel Horse attachment. These numbers should always be referred to when consulting with your dealer or factory concerning service, replacement parts, or questions you may have. For your reference, record numbers from Model and Serial Number plate on your attachment.

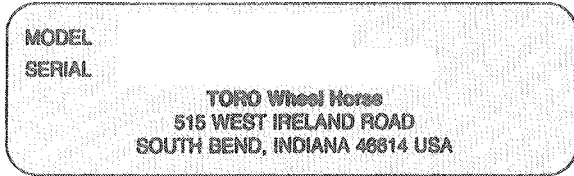

MOUNTING INFORMATION

This attachment is designed for use with 300, 400 and 500-Series gear drive or hydrostatic tractors.

ASSEMBLE SNOWTHROWER

Remove all parts from shipping box.

Remove two bolts, lock washers and cross bar from frame (Fig. 1). Locate long spring and hook longest spring end into idler pulley bellcrank. Hook short spring end into frame bracket with bolt (Fig. 2).

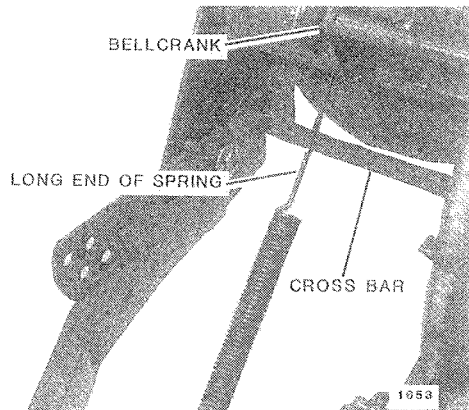

FIG. 1. Front Frame Cross Rod and Spring

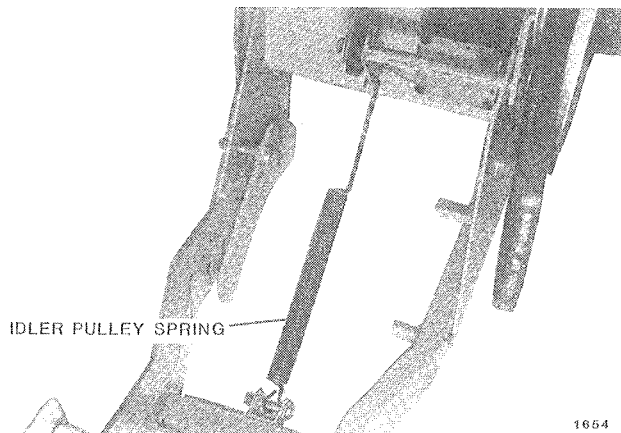

FIG. 2. Attach Idler Pulley Spring

Locate drive chain and rest chain on gear box sprocket (Fig. 3). Install frame assembly on wrapper assembly using removed cross bar, two bolts and lock washers and six 3/8-16 x 1 bolts and E. S. Nuts (Fig. 4).

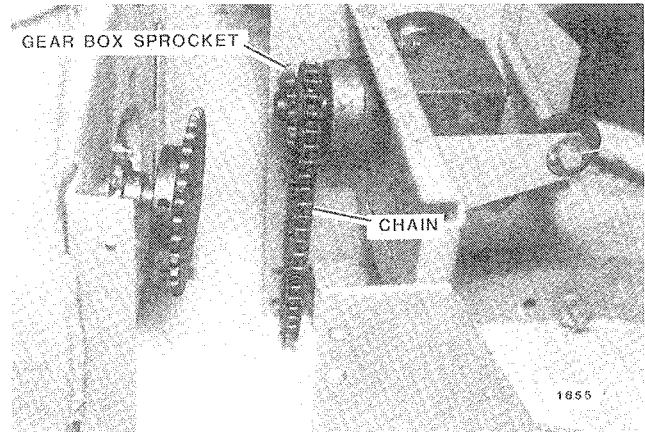

FIG. 3. Position Drive Chain

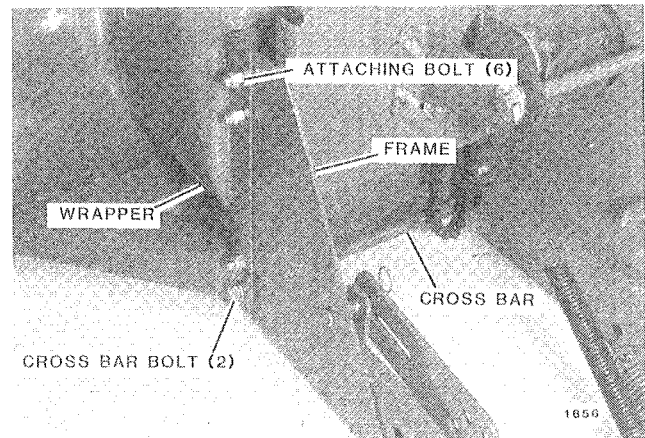

FIG. 4. Attach Frame to Wrapper

Install chain on sprockets (Fig. 5). Adjust wood block so that chain deflects 1/8 to 1/2 inch between sprockets.

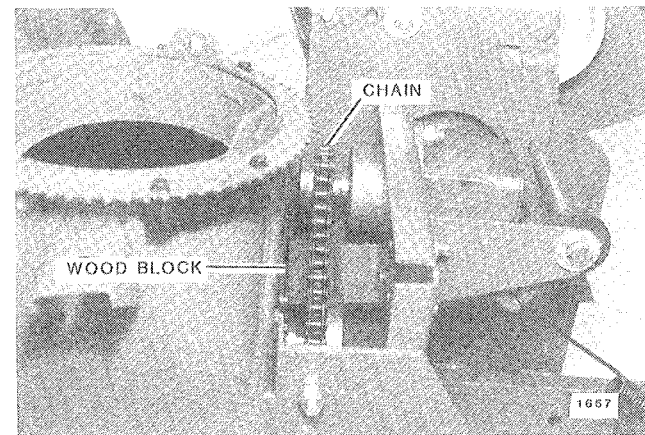

FIG. 5. Install and Adjust Drive Chain

Install cover using two 1/4-20 x 1/2 inch bolts (Fig. 6). Secure discharge chute to wrapper with three 5/16-18 x 3/4 carriage bolts, washers and E. S. Nuts. Install discharge

chute worm gear assembly on wrapper. Adjust worm gear so that chute turns freely.

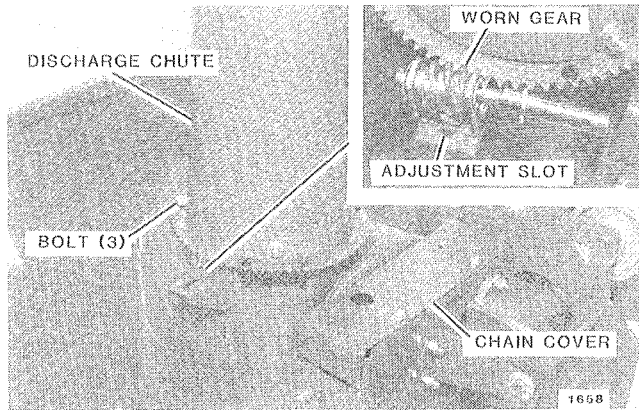

FIG. 6. Install Cover, Chute and Worm Gear

ATTACH SNOWTHROWER TO TRACTOR

Install drive belt guard bracket on tractor frame using two 3/8 x 2 bolts and E. S. Nuts (Fig. 7).

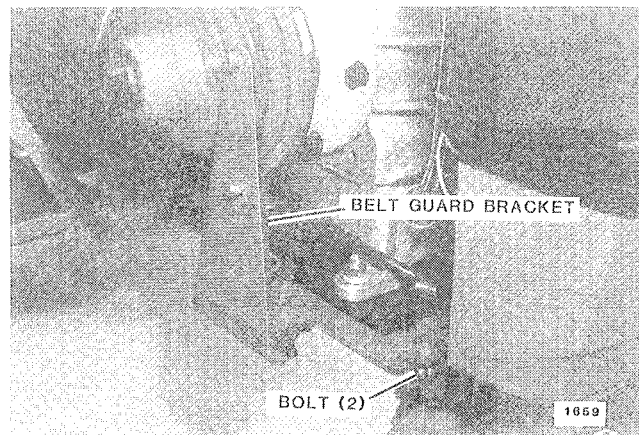

FIG. 7. Install Belt Guard Bracket

Install anti-sway bracket on belt guard bracket and secure with pin and hairpin cotter (Fig. 8). Make sure guide fits into front slot of belt guard.

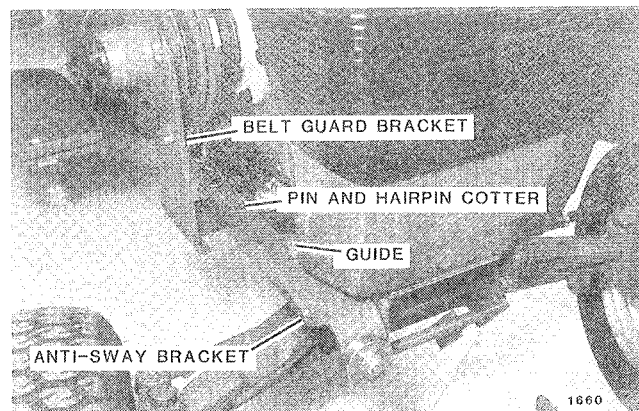

FIG. 8. Install Anti-Sway Bar

Open tractor mid-hitch and install snowthrower frame to tractor (Fig. 9).

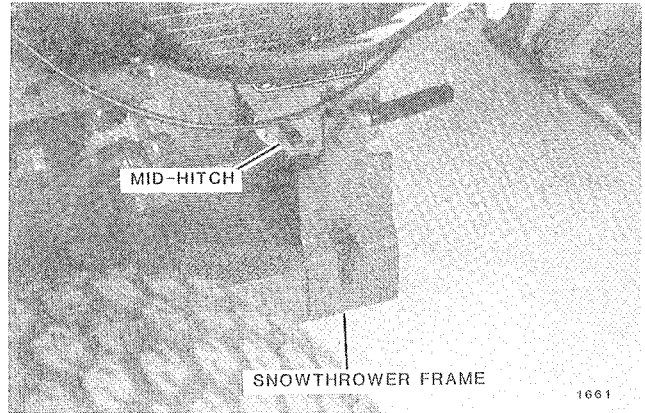

FIG. 9. Rear Snowthrower Mounting

Open tractor front hitch and install lift link to tractor (Fig. 10).

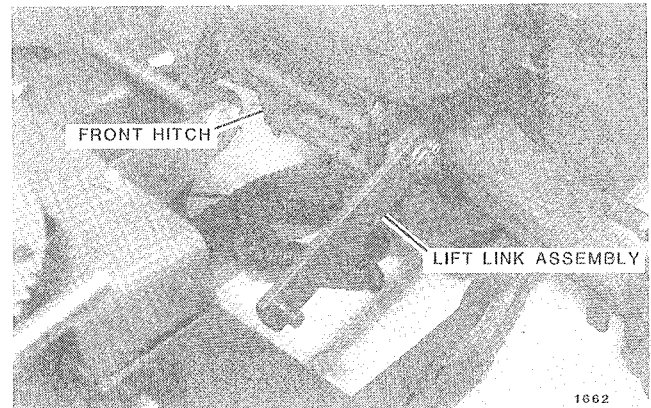

FIG. 10. Install Lift Link

Install front of lift rod into lift link and rear of lift rod into tractor lift arm using washers and hairpin cottes (Figs. 11 & 12).

Install lift link into rear bottom hole of snowthrower adjustment link and secure with hairpin cotter (Fig. 13). Install lift assist spring on lift rod and frame (Fig. 14).

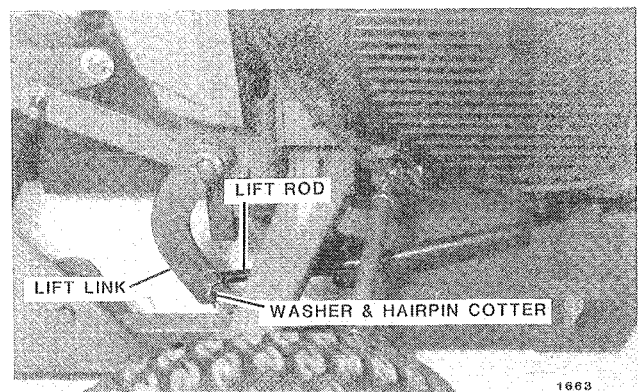

FIG. 11. Attach Front of Lift Arm

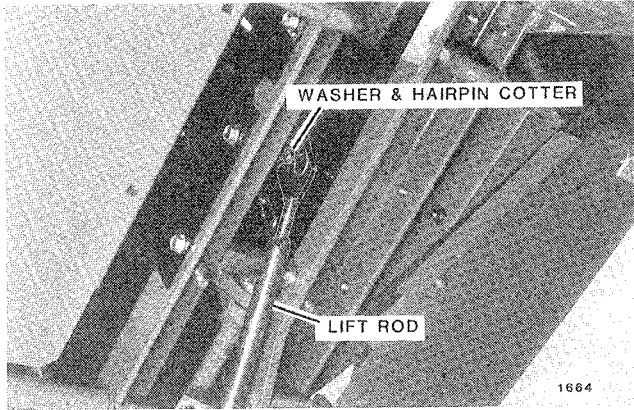

FIG. 12. Attach Rear of Lift Arm

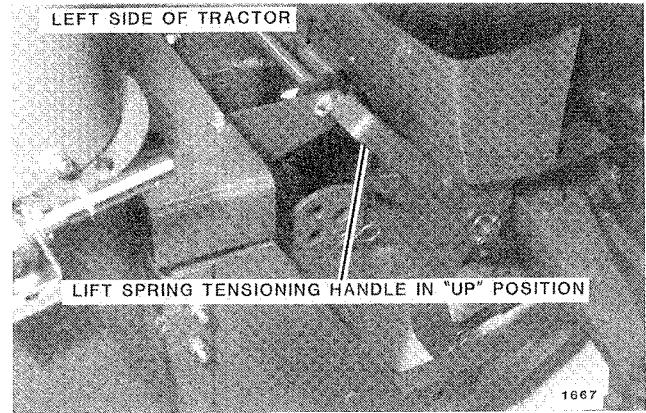

FIG. 15. MANDATORY - Handle in Up Position and Snowthrower Raised

Install lift spring on lift link and secure spring with retaining link and small hairpin cotter. hairpin cotter must be positioned as shown in Figure 16.

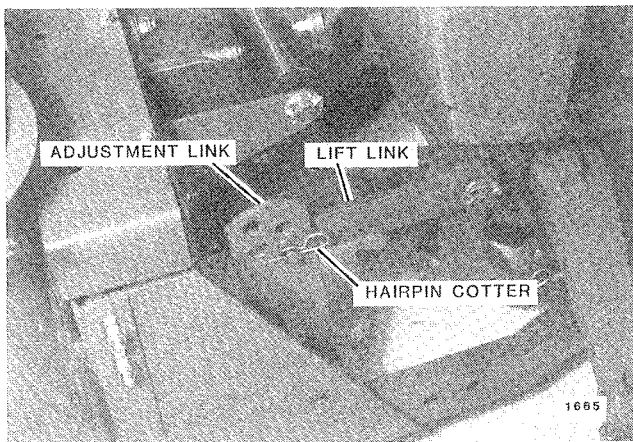

FIG. 13. Attach Lift Link to Snowthrower

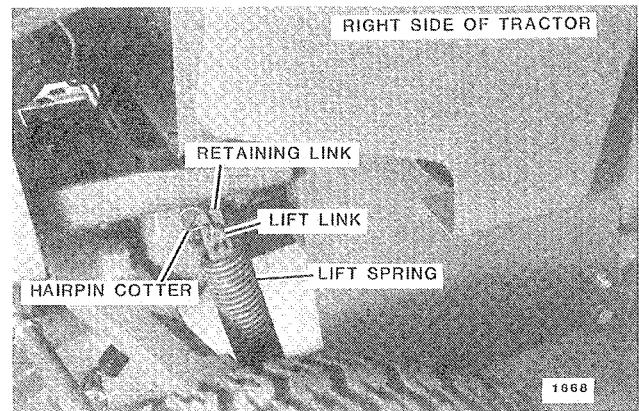

FIG. 16. Install Lift Spring

Move spring tension handle all the way down so that spring is over center and all the way toward rear of tractor (Fig. 17).

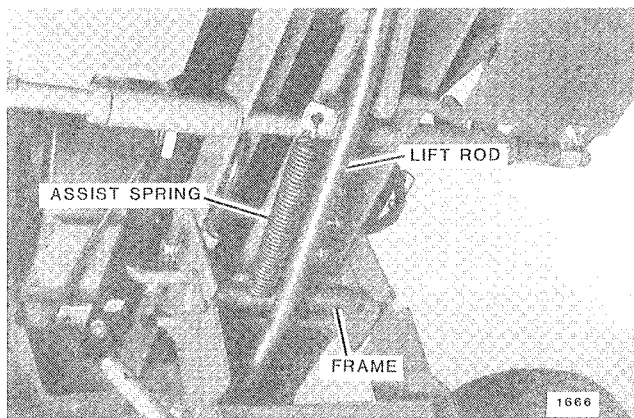

FIG. 14. Install Lift Assist Spring

MANDATORY STEP: Raise snowthrower all the way up with tractor lift. Move lift spring tensioning handle to rest against hood (Fig. 15).

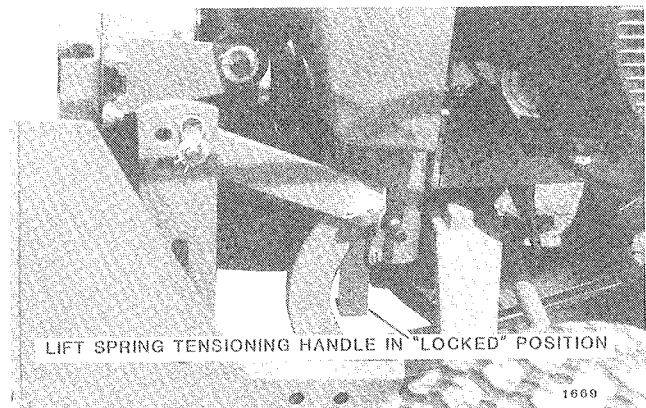

FIG. 17. Position Spring Tensioning Handle

Install drive belt on outside of tractor PTO as described in tractor operator's manual (Fig. 18). Install belt guard using two flat washers and small hairpin cotters (Fig. 19).

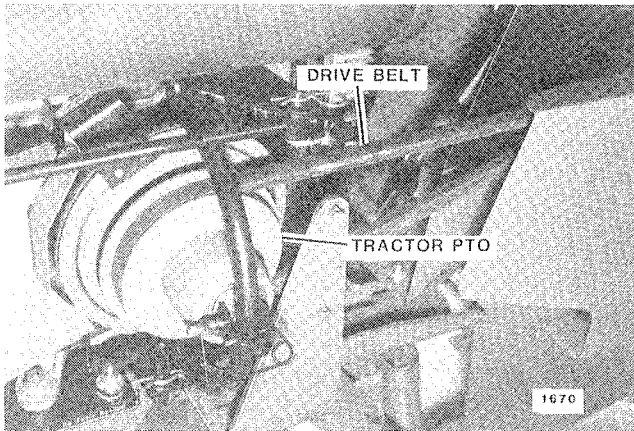

FIG. 18. Install Drive Belt

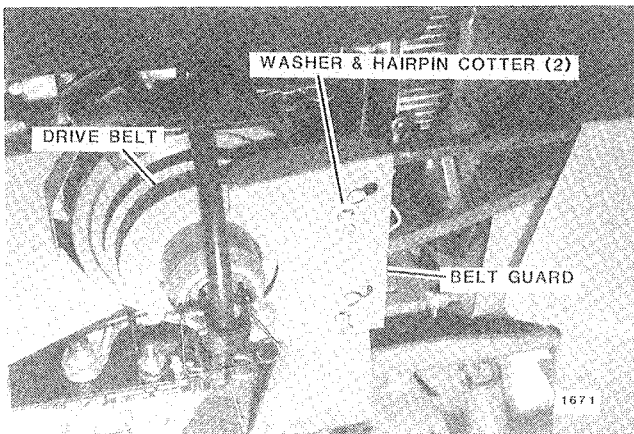

FIG. 19. Install Belt Guard

Install discharge chute crank support on snowthrower frame and secure with large hairpin cotter (Fig. 20). Insert crank through hole in support, install crank on discharge chute worm and secure with small hairpin cotter (Fig. 21).

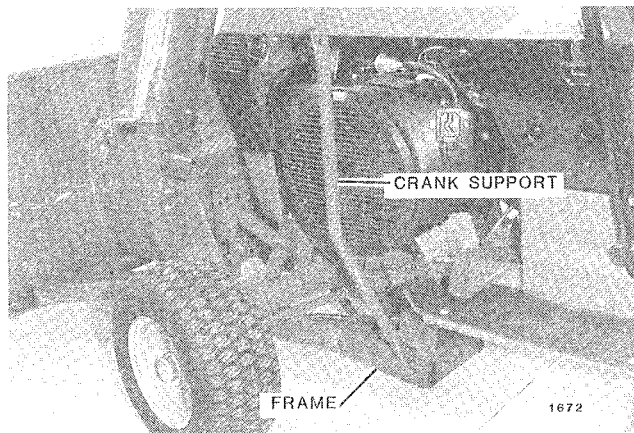

FIG. 20. Install Crank Support

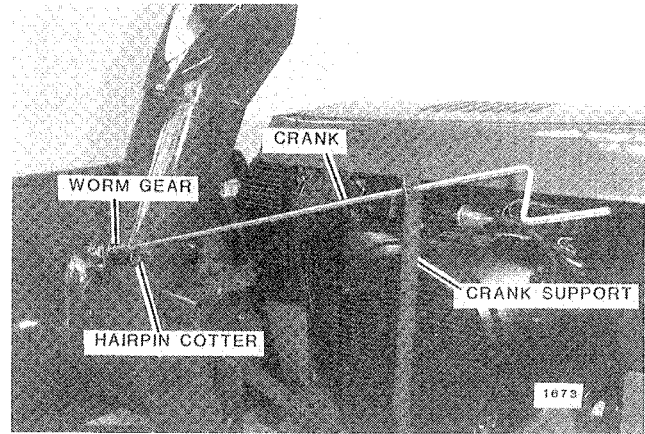

FIG. 21. Attach Crank to Discharge Chute

SNOWTHROWER REMOVAL AND INSTALLATION

After initial installation, snowthrower is removed and installed as follows:

REMOVAL

Remove discharge chute crank and support (Fig.22).

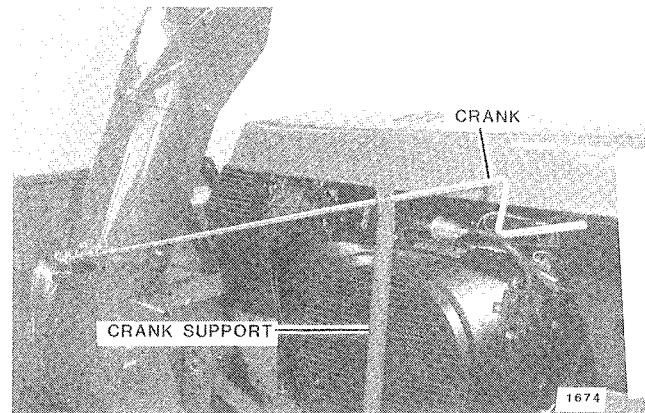

FIG. 22. Remove Crank and Support

MANDATORY STEP: Raise snowthrower all the way up with tractor lift and move lift spring tensioning handle to rest against hood (Fig. 23). **Note:** Spring is under severe pressure when snowthrower is in lowered position.

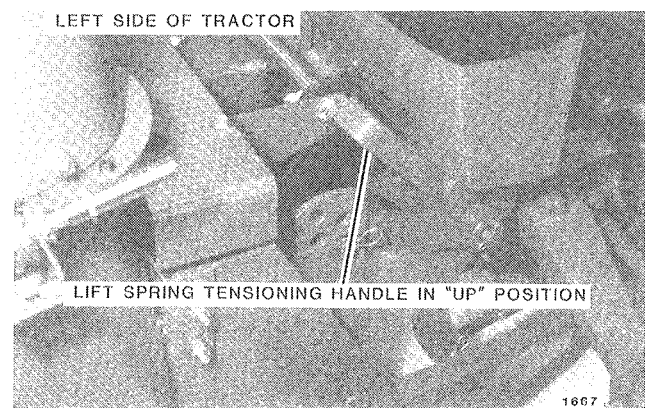

FIG. 23. MANDATORY - Handle in Up Position and Snowthrower Raised

Remove lift spring (Fig. 24). Lower snowthrower, remove lift rod from lift link and remove link from tractor front hitch (Fig. 25).

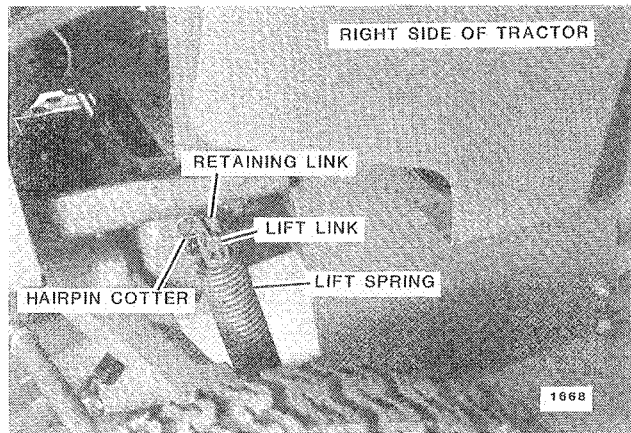

FIG. 24. Remove Spring

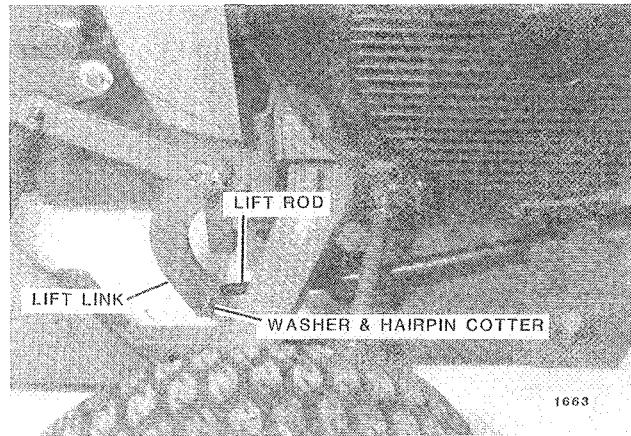

FIG. 25. Remove Lift Rod and Link

Remove Lift Rod and Spring from tractor (Fig. 26). Remove drive belt guard and drive belt (Fig. 27).

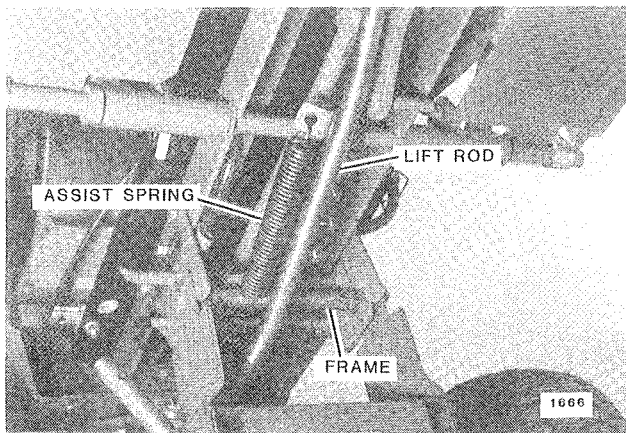

FIG. 26. Remove Rod and Spring

Remove snowthrower frame from tractor mid-hitch and back tractor away from snowthrower (Fig. 28).

Remove drive belt guard and anti-sway brackets from tractor (Fig. 29).

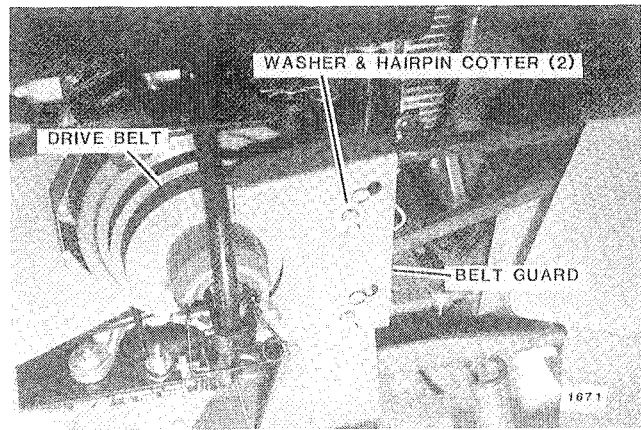

FIG. 27. Remove Drive Belt and Guard

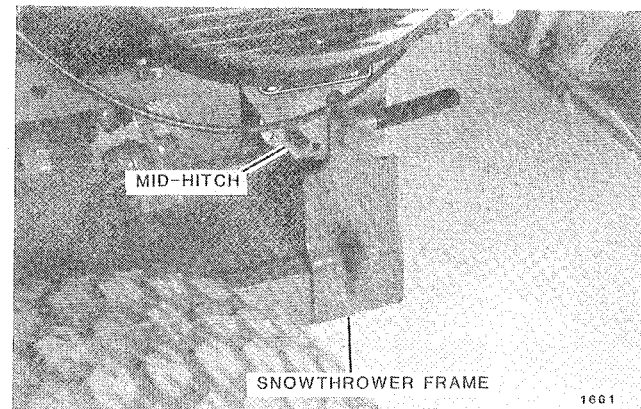

FIG. 28. Remove Frame From Tractor

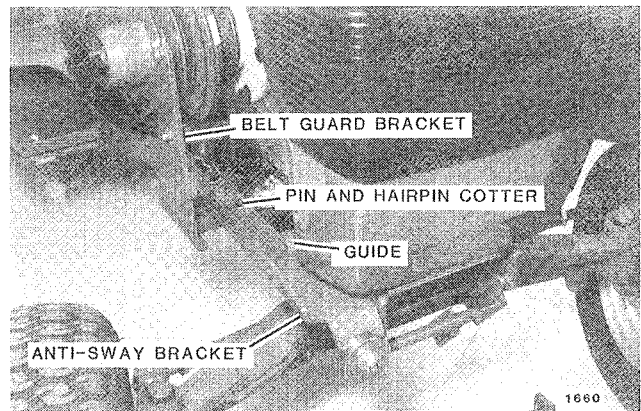

FIG. 29. Remove Brackets

INSTALLATION

Install snowthrower in reverse order as prescribed under "REMOVAL" procedure.

OPERATION AND ADJUSTMENT



To minimize the possibility of injury, become familiar with all safety suggestions at the front of this manual before placing the snowthrower into operation.

IMPORTANT

Each time snowthrower is installed, check for proper operation of PTO clutch and brake. Adjustment of PTO is covered in tractor Operator's Manual.

Use of rear wheel weights and tire chains is recommended for extra traction, particularly when heavy snow or icy conditions occur. These accessory items are available through your authorized Toro Wheel Horse dealer.

Direction snow is thrown is controlled by turning crank rod. Discharge chute will rotate through a 180 degree arc. Deflector on upper portion of discharge chute can be adjusted up and down to control height and distance snow is thrown.

Distance between auger and ground is regulated by skid shoes at each side of snowthrower housing (Fig. 30). Auger height should be adjusted so that scraper will not catch on uneven surfaces. When operating snowthrower over loose material, such as a gravel driveway, raise auger sufficiently to prevent picking up stones or other debris. To adjust auger height, raise snowthrower and loosen bolts securing skid shoes to side of snowthrower housing. Raise or lower skid shoes equally on both sides, to obtain level auger height.

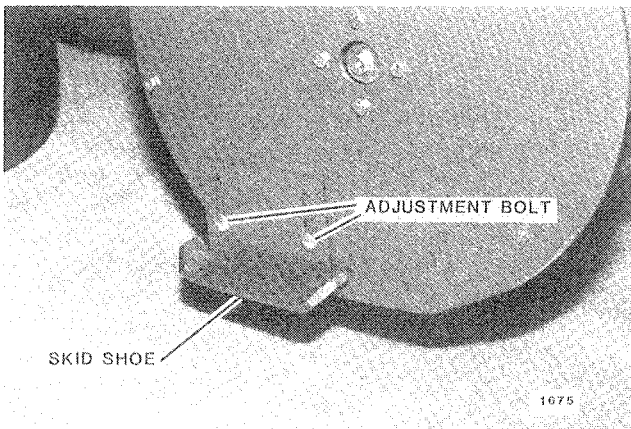

FIG. 30. Skid Shoe Adjustment



When making any adjustment to snowthrower, disengage PTO, shut off engine and remove ignition key. Make sure wire is installed in discharge chute (Fig. 31).

Snow removal conditions vary greatly. Depth of snow, wind direction, temperature and condition of area to be

cleared are all factors which must be taken into consideration when throwing snow. Best results are obtained with high auger speed and slow forward movement. Therefore, operate tractor at full engine speed, using transmission to adjust ground speed to about 1 MPH (1.6 KPH).

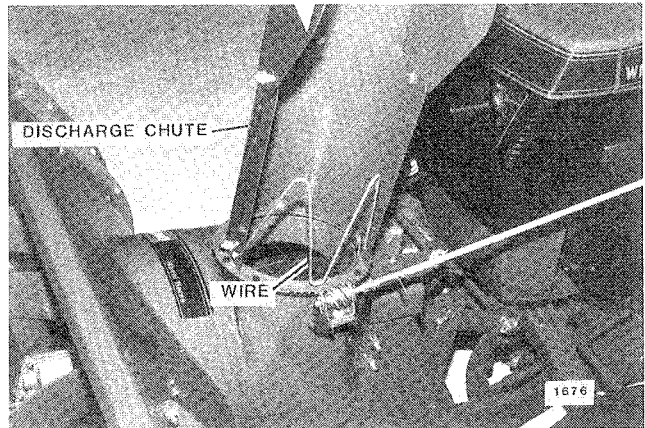

FIG. 31. Discharge Chute Wire

To begin snow removal, start tractor's engine and allow it to warm up. Lower snowthrower to ground using tractor's attachment lift, and then engage PTO.



Never permit anyone to stand in front of auger or discharge chute when tractor engine is running. Keep children and pets away from area when throwing snow. There may be objects in snow being thrown which could cause injury to anyone being struck by them.

A definite pattern of operating is required to thoroughly clean snow area. This will avoid a second removal of snow and throwing snow into unwanted places. Snow should be thrown downwind. However, where it is possible to throw snow to right and left, as on a long driveway, it is advantageous to start in middle and work progressively outward, throwing snow to both sides without changing position of discharge chute (Fig. 32).

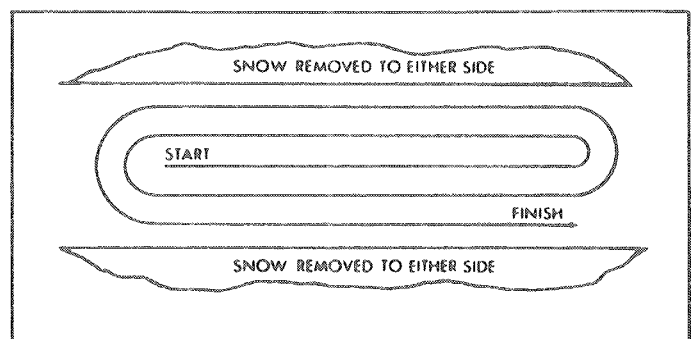

FIG. 32. Throwing Snow To Both Sides

If snow can only be thrown to one side, start on side farthest from where snow is to be thrown, rotating discharge chute 180 degrees at end of each pass.

Before starting tractor engine, make sure auger and impeller will rotate freely. This is especially important when unit has been in use and left standing in cold weather. Auger or impeller could be frozen in housing and, if PTO clutch is engaged under these conditions, clutch or belt or both could be damaged. Also check discharge chute to be sure it is free to turn.

For normal operations, snowthrower is used with unit resting on ground. Lift distance is shown in Figure 33.

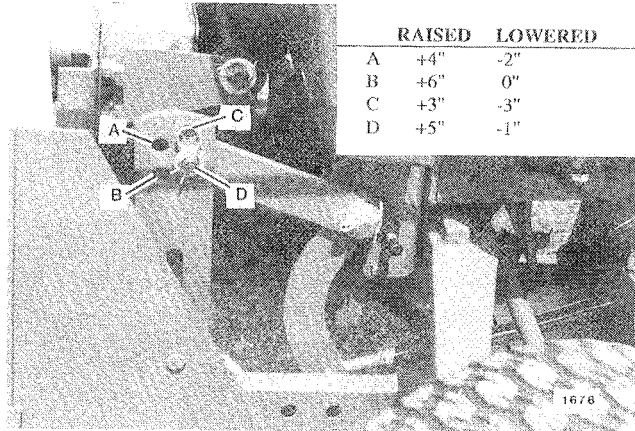

FIG. 33. Ground Clearance

In deep, drifted, or banked snow, it will be necessary to slowly drive auger into snow and then stop tractor to allow auger to clear snow. Repeat this method until a path is cleared. On second pass, overlap first path enough to allow snowthrower to operate without repeated stopping and starting of tractor.

In extremely deep snow, raise snowthrower from ground using tractor's attachment lift. Drive tractor ahead into deep snow, removing top layer first. Tractor itself should not enter snowbank. Reverse tractor and lower snowthrower to ground. Drive tractor ahead and repeat process to remove balance of snow. Working with repeated passes in and out of drifts will eventually move deep snow.

CAUTION

If snowthrower becomes plugged with snow or jammed due to hitting a foreign object, proceed as follows:

1. **Disclutch snowthrower and stop tractor engine immediately.**
2. **Disconnect spark plug wire(s)**
3. **Clear snow from discharge chute or impeller if plugged.**
4. **If auger or impeller is jammed, remove foreign object and repair any damage to snowthrower before continuing.**
5. **Reconnect spark plug wire(s).**
6. **Resume operation.**

Snowthrower should not be used to remove ice or hard packed frozen snow, which can cause damage to unit. For best results, snow should be removed as soon as possible after it falls.

Before snow season begins, it is suggested that snow removal area be thoroughly inspected and cleared of all stones, sticks, etc. which might be picked up by auger. Mark location of all obstacles that could become hidden under snow and cause damage to auger or tractor if struck.

MAINTENANCE AND STORAGE

Before each use, check that all bolts, set screws and other fasteners are tight and in place. Drive chain tension can be adjusted by moving wood block so that chain deflects 1/8-1/2" between sprockets (Fig. 34). Reinstall cover after adjustment.

Do not overtighten chain. A correctly adjusted chain will have a slight amount of slack. An overtightened chain will result in early failure of the wood block.

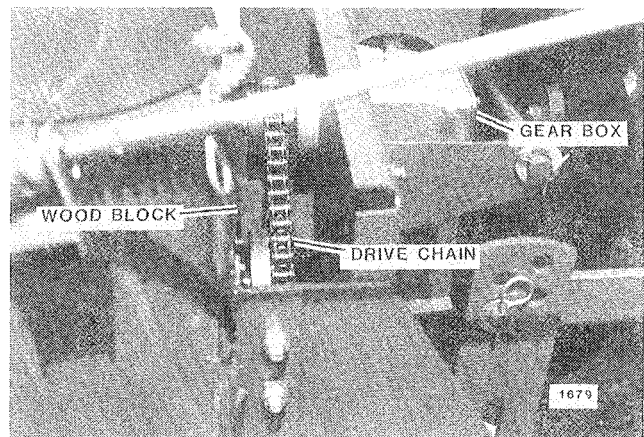

FIG. 34. Drive Chain Adjustment and Gear Box

Lubricate drive chain every 4 operating hours with SAE 10 Or SAE 10w30 engine oil. Be sure oil penetrates inside each roller. Wipe off excess oil. Other moving parts of linkage should be lubricated with light engine oil. Grease impeller bearing at first 5 hours with #2 multi-purpose grease and thereafter every 50 hours or at end of each season (Fig. 35).

Auger and impeller are driven with gearboxes (Fig. 34 & 36). Gearboxes are filled with EP90 oil at factory. Oil changes on drive chain gearbox is not necessary except for major service or oil leaks. Oil should be changed in auger gearbox at first 5 hours and thereafter at 50 hours.

A coat of wax applied to inside of auger housing will help prevent snow from sticking to it. Inside of discharge chute and deflector should also be waxed several times during snow removal season. Coat bare metal surfaces of snowthrower with oil or grease to prevent rust until permanent repairs can be made. Contact with corrosive road salt should be avoided whenever possible.

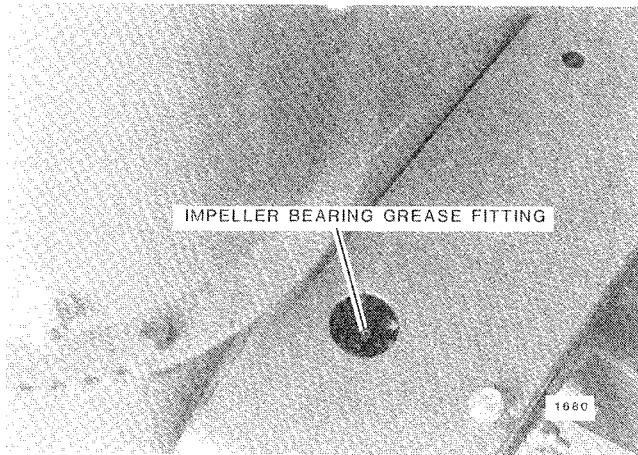

FIG. 35. Lubricate Impeller Bearing

To prevent damage to snowthrower housing, periodically inspect snowthrower scraper. When scraper becomes worn (before working surface comes in contact with housing) remove carriage bolts attaching scraper to housing and replace scraper (Fig. 36)

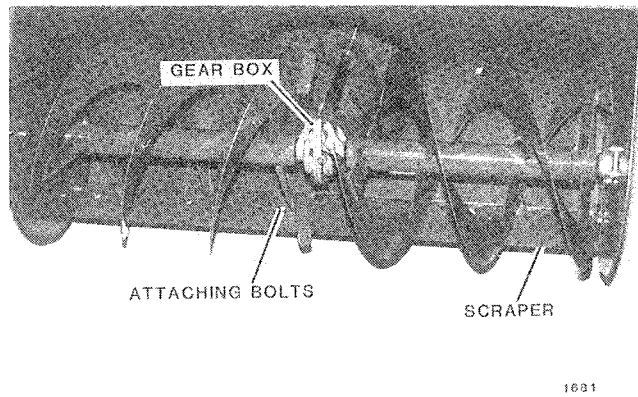

FIG. 36. Reversible Scraper and Gear Box

Before storing snowthrower at end of season, thoroughly clean it by washing with a garden hose. A mild automotive type detergent may be used to remove stubborn dirt. Touch up damaged paint areas as necessary. Aerosol cans of "Toro Wheel Horse Red" touch up paint are available through your authorized dealer.

Auger should be coated with oil or treated with a rust preventative. Lubricate snowthrower as described in this section and store it in a clean, dry place. Protect it with a weather-proof cover if stored outdoors.

DRIVE BELT REPLACEMENT

Remove two belt guards (Fig. 37). Remove belt from PTO pulley as described in tractor's Operator's Manual. Loosen rear belt idler pulley and remove belt (Fig. 38).

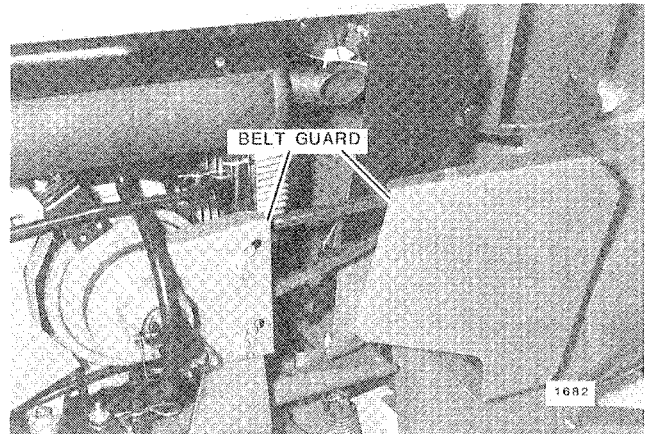

FIG. 37. Remove Belt Covers

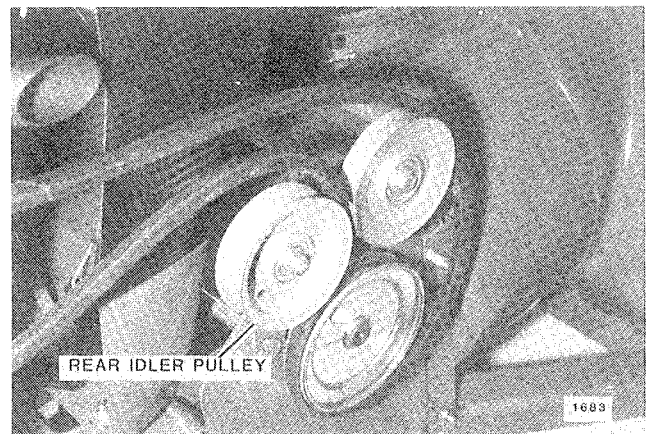

FIG. 38. Loosen Idler Pulley

Install new belt on pulleys and tighten rear idler pulley bolt (Fig.39). Install belt on PTO and reinstall belt guards.

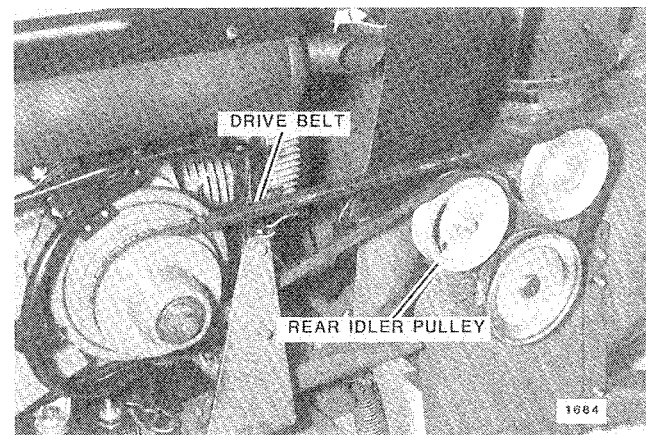

FIG. 39. Drive Belt Routing



Consumer Products

THE TORO TOTAL COVERAGE GUARANTEE A Full Two-Year Warranty (Limited Warranty for Commercial Use)

What Is Covered By This Express Warranty?

The Toro Company promises to repair any TORO Product used for residential purposes if defective in materials or workmanship for a period of two years from the date of purchase. The cost of parts and labor are included, but the customer pays the transportation costs.

Transportation within a 15 mile radius of the servicing dealer is covered under this warranty for two-stage snowthrowers, walk behind debris equipment and all TORO Wheel Horse riding products. Walk power mowers, single stage snowthrowers, and other products not specifically covered, are excluded from the transportation coverage provided by this warranty.

What Products Are Covered By This Warranty?

This warranty applies to all gasoline powered Consumer Products (including TORO Wheel Horse riding products), ProLine riding products, wide area walk behind mowers and 21" Commercial mowers without blade stop controls are covered by separate warranty statements.

How About Commercial Use?

TORO Consumer Products used for commercial, institutional or rental use are covered by a limited warranty for the following time periods from the date of purchase:

Products	Warranty Period
• Garden Tractors	
Chassis	1 year limited warranty
Engine	2 year limited warranty
• 21" Commercial Duty Walk Mower with blade stop controls	1 year limited warranty
• Lawn Tractors, Yard Tractors, Rear Engine Riders, 3.0 and 3.5 HP Edgers, Straight Shaft Trimmers, and Backpack Blowers	90 day limited warranty
• All Others	45 day limited warranty

How Do You Get Warranty Service?

Should you feel your TORO product contains a defect in material or workmanship, contact the dealer who sold you the product or any Authorized TORO Service Dealer or TORO Master Service Dealer. The Yellow Pages of your telephone directory is a good reference source. The dealer will either arrange service at his/her dealership or recommend another Authorized Service Dealer who may be more convenient. You may need proof of purchase (copy of registration card, sales receipt, etc.) for warranty validation.

If for any reason you are dissatisfied with the Service Dealer's analysis of the defect in materials or workmanship or if you need a referral to a TORO Service Dealer, please feel free to contact us at the following address:

Toro Customer Service Department
8111 Lyndale Avenue South
Bloomington, MN 55420-1196
612-888-8801

What Must You Do To Keep The Warranty In Effect?

You must maintain your TORO Product by following the maintenance procedures described in the operator's manual. Such routine maintenance, whether performed by a dealer or by you, is at your expense.

What Does This Warranty Not Cover? and

How Does Your State Law Relate To This Warranty?

There is no other express warranty except the TORO Starting Guarantee on GTS Engines. This express warranty does not cover:

- Cost of regular maintenance service or parts, such as filters, fuel, lubricants, tune-up parts, blade sharpening, brake and clutch adjustments.
- Any product or part which has been altered or misused or required replacement or repair due to normal wear, accidents, or lack of proper maintenance.
- Repairs necessary due to improper fuel, contaminants in the fuel system, or failure to properly prepare the fuel system prior to any period of non-use over three months.
- Pickup and delivery charges for distances beyond a 15 mile radius from an Authorized TORO Service Dealer (covered products only).

All repairs covered by this warranty must be performed by an Authorized TORO Service Dealer using Toro approved replacement parts.

Repair by an Authorized TORO Service Dealer is your sole remedy under this warranty.

The Toro Company is not liable for indirect, incidental or consequential damages in connection with the use of the TORO Products covered by this warranty, including any cost or expense of providing substitute equipment or service during reasonable periods of malfunction or non-use pending completion of repairs under this warranty. Some states do not allow exclusions of incidental or consequential damages, so the above exclusion may not apply to you.

This warranty gives you specific legal rights, and you may also have other rights which vary from state to state.

COUNTRIES OTHER THAN THE UNITED STATES OR CANADA

Customers who have purchased TORO products exported from the United States or Canada should contact their TORO Distributor (Dealer) to obtain guarantee policies for your country, province, or state. If for any reason you are dissatisfied with your Distributor's service or have difficulty obtaining guarantee information, contact the TORO importer. If all other remedies fail, you may contact us at The Toro Company.