



**Count on it.**

**Parts Catalog**

**Power Max 826 OE Snowthrower**

Model No. 38817—Serial No. 314000001 and Up



# Ordering Replacement Parts

To order replacement parts, please supply the part number, the quantity, and the description of each part desired.

## Understanding Reference Numbers

Each identified part in an illustration has a reference number. The reference number for a part also appears in the parts list, along with other information about the part.

This catalog uses two special reference number formats, one to indicate parts in a service assembly and another to indicate the quantity of a given part in an illustration.

## Service Assembly Reference Numbers

Parts in service assemblies have reference numbers in the form a:b. The a represents the reference number of the entire service assembly and the b represents a sequential number unique to each part within the service assembly.

For example, a wheel assembly might be identified by reference number 6, the tire by 6:1, the valve by 6:2, and the wheel by 6:3. When you order the assembly identified by reference number 6, you receive all parts identified by reference numbers 6:1, 6:2, and 6:3. However, you may also order any part individually. Reference numbers of this type appear in illustration and in parts lists.

## Reference Numbers Indicating Quantity

In an illustration, if a reference number indicates more than one part, the reference number has the form nX y. The n represents the quantity of the part, the X is the multiplication symbol, and the y represents the reference number.

For example, in an illustration, the reference number 2X 37 means that two of the parts identified by reference number 37 are indicated.

# List of Abbreviations

<b>AR:</b> as required	<b>HLH:</b> hex lag head	<b>PTO:</b> power-take-off
<b>ASM:</b> assembly	<b>HOC:</b> height-of-cut	<b>RH:</b> right hand
<b>BBC:</b> blade brake control	<b>HSBH:</b> hex socket button head	<b>ROPS:</b> roll-over protection system
<b>BHTF:</b> button head thread forming	<b>HSFH:</b> hex socket flat head	<b>RRB:</b> rear roller brush
<b>CARR:</b> carriage	<b>HSH:</b> hex socket head	<b>SFH:</b> slotted fillister head
<b>CCW:</b> counter clockwise	<b>HWH:</b> hex washer head	<b>SHH:</b> slotted hex head
<b>CW:</b> clockwise	<b>HWHTF:</b> hex washer head thread forming	<b>SHWH:</b> slotted hex washer head
<b>DEG:</b> degrees	<b>HYD:</b> hydraulic	<b>SPH:</b> slotted pan head
<b>DPA:</b> Dual Point Adjustment	<b>LH:</b> left hand	<b>SQH:</b> square head
<b>ECM:</b> electronic control module	<b>LP:</b> Liquefied Petroleum Gas	<b>SRH:</b> slotted round head
<b>EXT:</b> external	<b>LPG:</b> Liquefied Petroleum Gas	<b>STD:</b> standard
<b>FH:</b> flat head	<b>NI:</b> nylon insert	<b>TAP:</b> self tapping
<b>GA:</b> gauge	<b>NPTF:</b> national pipe thread fine	<b>TTH:</b> torx truss head
<b>HD:</b> heavy-duty	<b>PFH:</b> phillips flat head	
<b>HF:</b> hex flange	<b>PPH:</b> phillips pan head	
<b>HH:</b> hex head	<b>PPHTF:</b> phillips pan head thread forming	
<b>HHF:</b> hex head flange	<b>PRH:</b> phillips round head	
<b>HHFTF:</b> hex head flange thread forming	<b>PTH:</b> phillips truss head	
<b>HJ:</b> hex jam		

# Contents

Frame, Housing and Bypass Assembly .....	4
Pulleys and Bellcrank Assembly .....	5
Impeller Drive Assembly .....	6
Drive Assembly .....	7
Gearbox, Auger and Impeller Assembly .....	8
26 Inch Auger Gearcase Assembly No. 119-7641 .....	9
Impeller Assembly .....	10
Engine Assembly .....	11
Chute Assembly .....	12
Quick Stick Assembly .....	13
Handle Assembly .....	14
Control Assembly .....	15
Attachments and Accessories .....	16

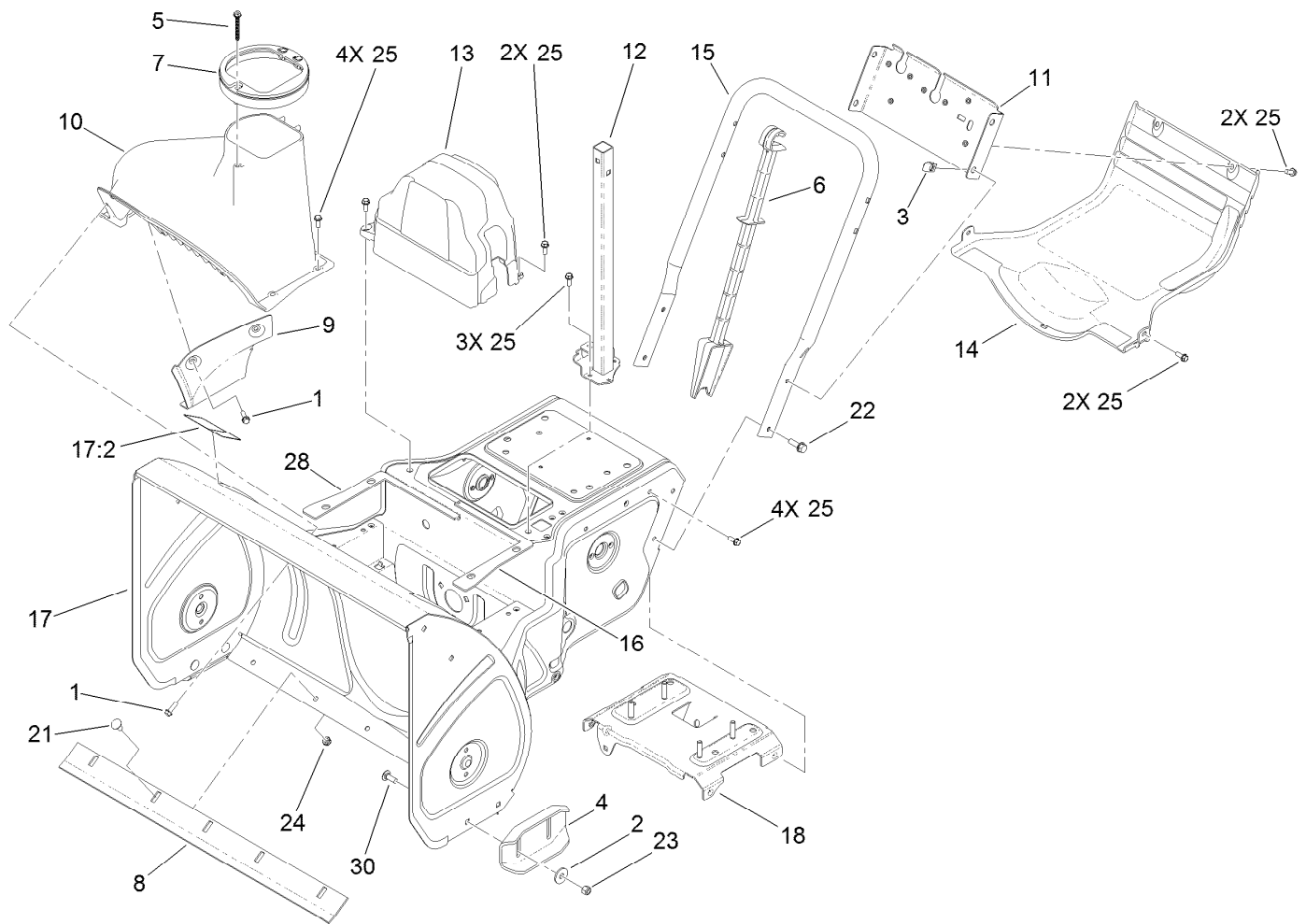

## Frame, Housing and Bypass Assembly

<i>Ref.</i>	<i>Part Number</i>	<i>Qty.</i>	<i>Description</i>	<i>Ref.</i>	<i>Part Number</i>	<i>Qty.</i>	<i>Description</i>
1	46-8091	6	Screw-HWH	14	120-7178	1	Cover-Lower
2	52-2861	4	Washer	15	120-7179-03	1	Handle-Lower
3	94-2413	4	U-Nut	16	120-7181	1	Seal-Housing, LH
4	106-4588-01	2	Skid	17	121-6811	1	Frame ASM
5	114-3751	1	Screw-HWH, Plastite	17:2	121-6817	1	Decal-Danger, Auger
6	121-6833	1	Stick-Cleanout	18	121-1218	1	Engine Stud Plate ASM
7	119-7626	1	Guide-Chute	21	3230-18	5	Screw-CARR
8	120-3872-01	1	Scraper-26 Inch	22	3234-29	4	Screw-HHF
9	120-7158-01	1	Cover-Liner	23	3296-29	4	Nut-Lock, NI
10	120-7159	1	Cover	24	3296-47	5	Nut-Lock, NI
11	120-7161-01	1	Brace-Frame	25	32144-85	17	Screw-HWH
12	120-7170-03	1	Chute Support ASM	28	121-6841	1	Seal-Housing, RH
13	120-7177	1	Cover-Belt	30	3230-23	4	Screw-CARR

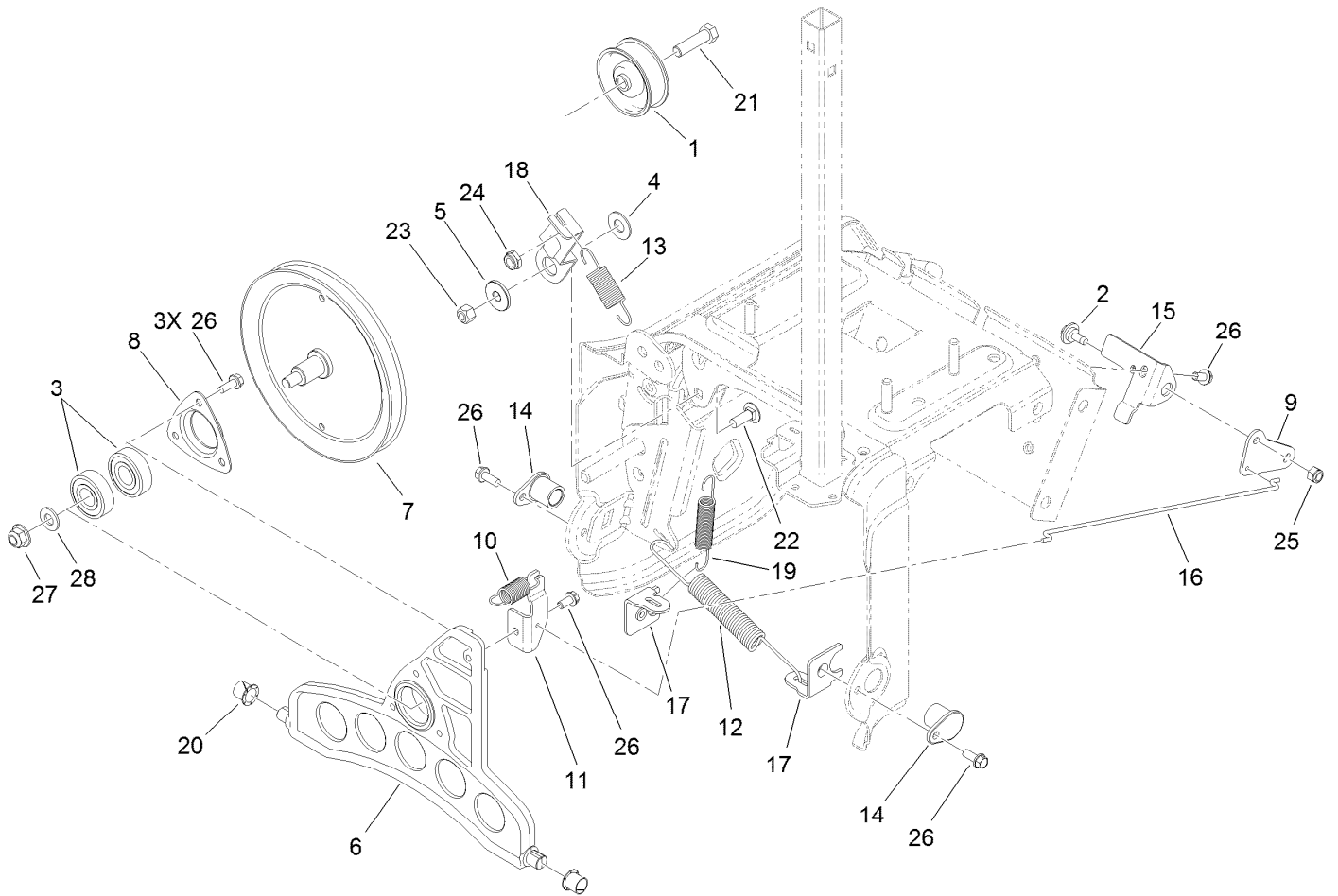

## Pulleys and Bellcrank Assembly

<i>Ref.</i>	<i>Part Number</i>	<i>Qty.</i>	<i>Description</i>	<i>Ref.</i>	<i>Part Number</i>	<i>Qty.</i>	<i>Description</i>
1	3-4244	1	Pulley-Idler	15	120-7165-03	1	Bracket-Bellcrank
2	92-9698	1	Screw-Shoulder	16	120-7166	1	Link-Drive
3	100-1048	2	Bearing-Ball	17	120-9271	2	Bracket-Anchor, Spring
4	25-5640	1	Washer	18	120-9273	1	Arm-Idler, Traction
5	117-7711	1	Bushing-Idler	19	120-9275	1	Spring-Extension
6	119-7645	1	Plate-Wheel, Friction	20	256-257	2	Bushing-Nyliner
7	119-7648	1	Traction Pulley ASM	21	323-29	1	Screw-HH
8	119-7649	1	Retainer-Bearing	22	3230-10	1	Screw-CARR
9	119-7670-03	1	Bellcrank-Drive	23	3296-29	1	Nut-Lock, NI
10	119-7676	1	Spring-Extension	24	3296-59	1	Nut-Lock, NI
11	119-7679	1	Bracket-Plate, Traction	25	3296-73	1	Nut-Lock, NI
12	120-3883	1	Spring-Extension	26	32144-85	7	Screw-HWH
13	120-3888	1	Spring-Extension	27	104-8301	1	Nut-Flange, NI
14	120-7156	2	Bushing-Plate, Traction	28	3256-24	1	Washer-Flat

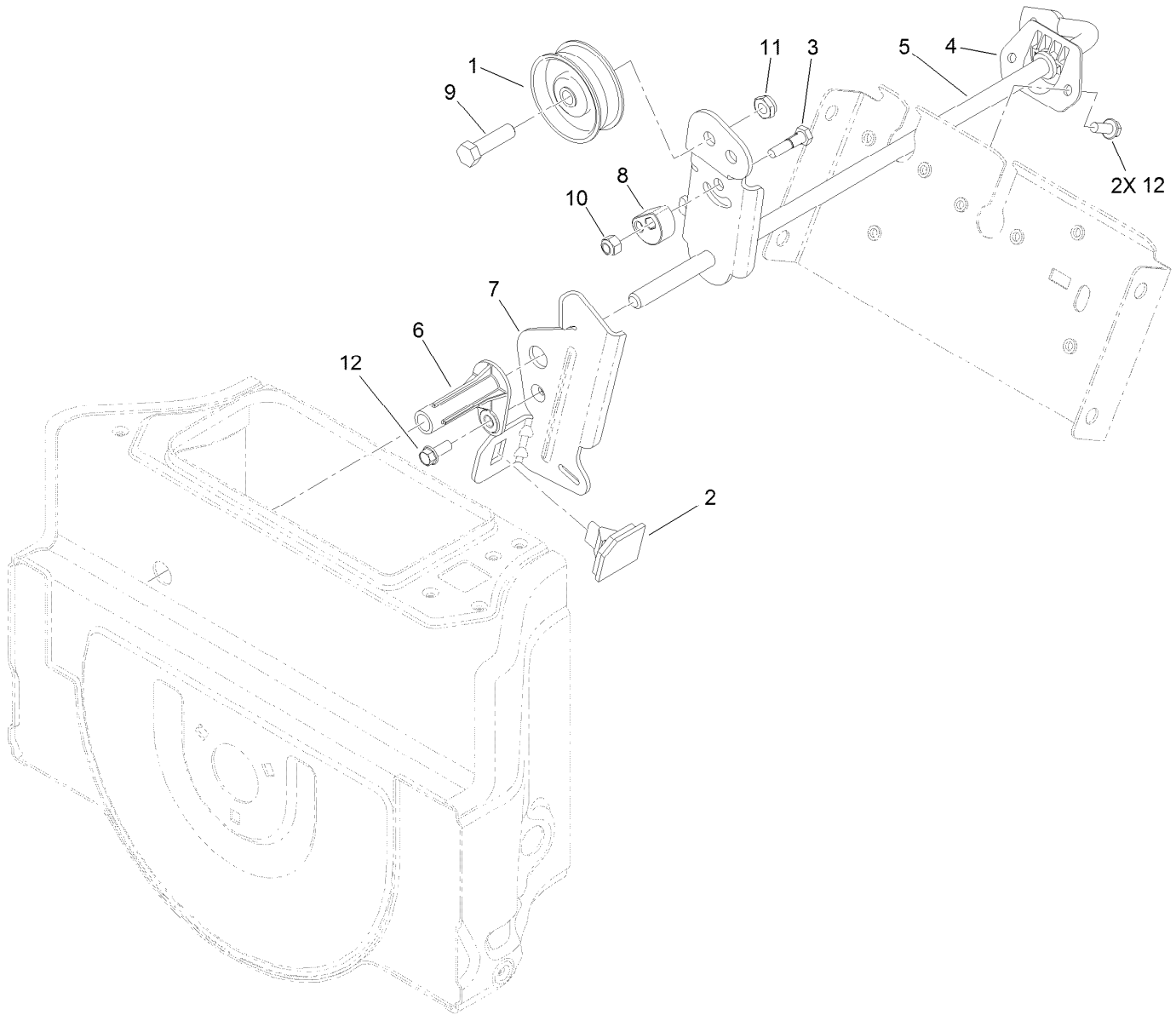

## Impeller Drive Assembly

<i>Ref.</i>	<i>Part Number</i>	<i>Qty.</i>	<i>Description</i>
1	3-4244	1	Pulley-Idler
2	66-8060	1	Pad-Brake
3	119-3301	1	Bolt-Pivot, Eccentric
4	120-7167	1	Bushing-Rod, Clutch
5	120-9254-03	1	Impeller Clutch ASM
6	120-9256	1	Pivot-Brake, Impeller
7	120-9257-03	1	Arm-Brake, Impeller
8	120-9276	1	Eccentric-Brake, Impeller
9	323-29	1	Screw-HH
10	3296-42	1	Nut-Lock, NI
11	3296-59	1	Nut-Lock, NI
12	32144-85	3	Screw-HWH

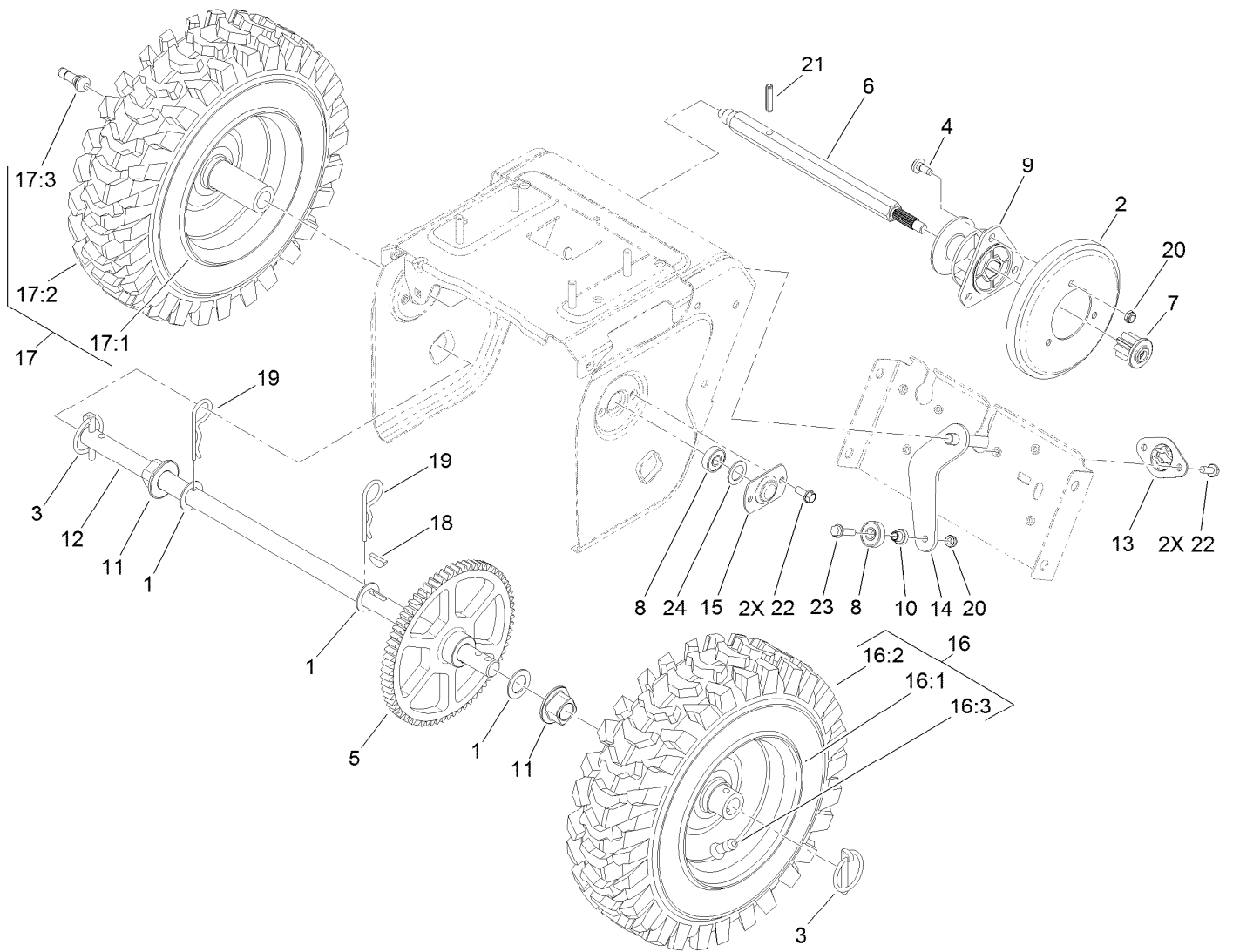

## Drive Assembly

Ref.	Part Number	Qty.	Description	Ref.	Part Number	Qty.	Description
1	3-8664	3	Washer-Thrust	16		1	LH Wheel And Tire ASM ●
2	119-1567	1	Wheel-Friction	16:1	121-1212	1	Wheel
3	107-3039	2	Klik Pin ASM	16:2	121-6820	1	Tire
4	120-7950	3	Screw-Shoulder	16:3	232-27	1	Stem-Valve
5	119-7613	1	Gear-Axle	17		1	RH Wheel And Tire ASM ●
6	119-7615	1	Shaft-Hex	17:1	121-1212	1	Wheel
7	119-7616	1	Gear-Pinion, 8 Tooth	17:2	121-6820	1	Tire
8	121-6835	3	Bearing-Ball, 10Mm	17:3	232-27	1	Stem-Valve
9	119-7630	1	Trunnion	18	3257-7	1	Key-Woodruff
10	119-7684	1	Spacer-Plate, Shift	19	3290-343	2	Pin-Hair
11	120-7162	2	Bushing-Axle	20	3296-56	4	Nut-Lock, NI
12	120-7180	1	Axle	21	32121-9	1	Pin-Roll, Slotted
13	120-7191	1	Retainer-Plate, Shift	22	32144-85	6	Screw-HWH
14	120-7193-03	1	Shift Plate ASM	23	32144-86	1	Screw-HWHTF
15	120-9266	2	Retainer-Bearing, 10Mm	24	121-6840	2	Washer-Rubber

● Not serviced separately

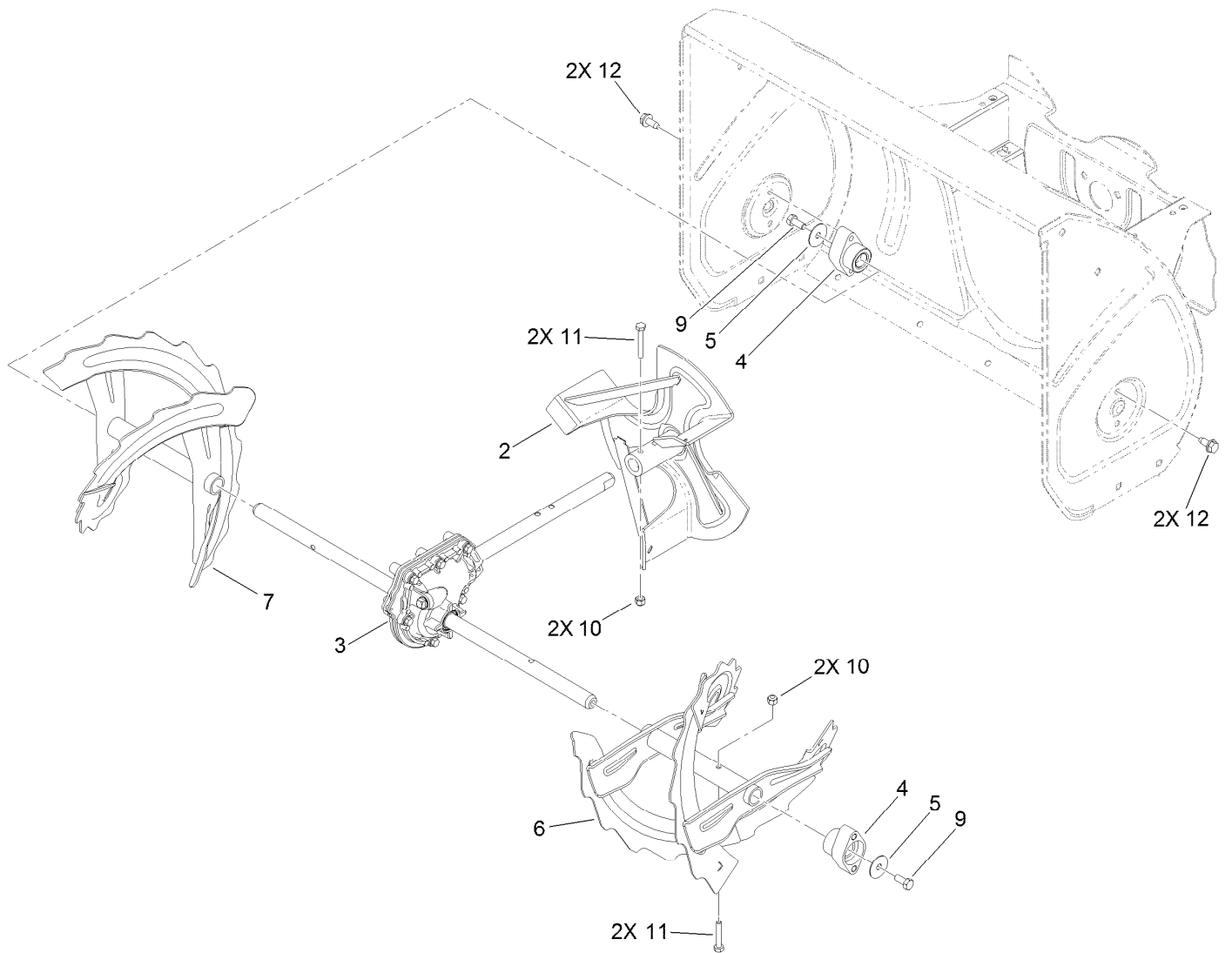

## Gearbox, Auger and Impeller Assembly

Ref.	Part Number	Qty.	Description
2	119-7612-03	1	Impeller ASM
3	119-7641	1	Gearcase ASM
4	120-3860	2	Bearing-Auger
5	120-3862	2	Washer-Thrust
6	120-9287-03	1	LH Auger ASM
7	120-9290-03	1	RH Auger ASM
9	322-3	2	Screw-HH
10	3296-42	4	Nut-Lock, NI
11	321-10	4	Screw-HH
12	32144-70	4	Screw-HWHTF



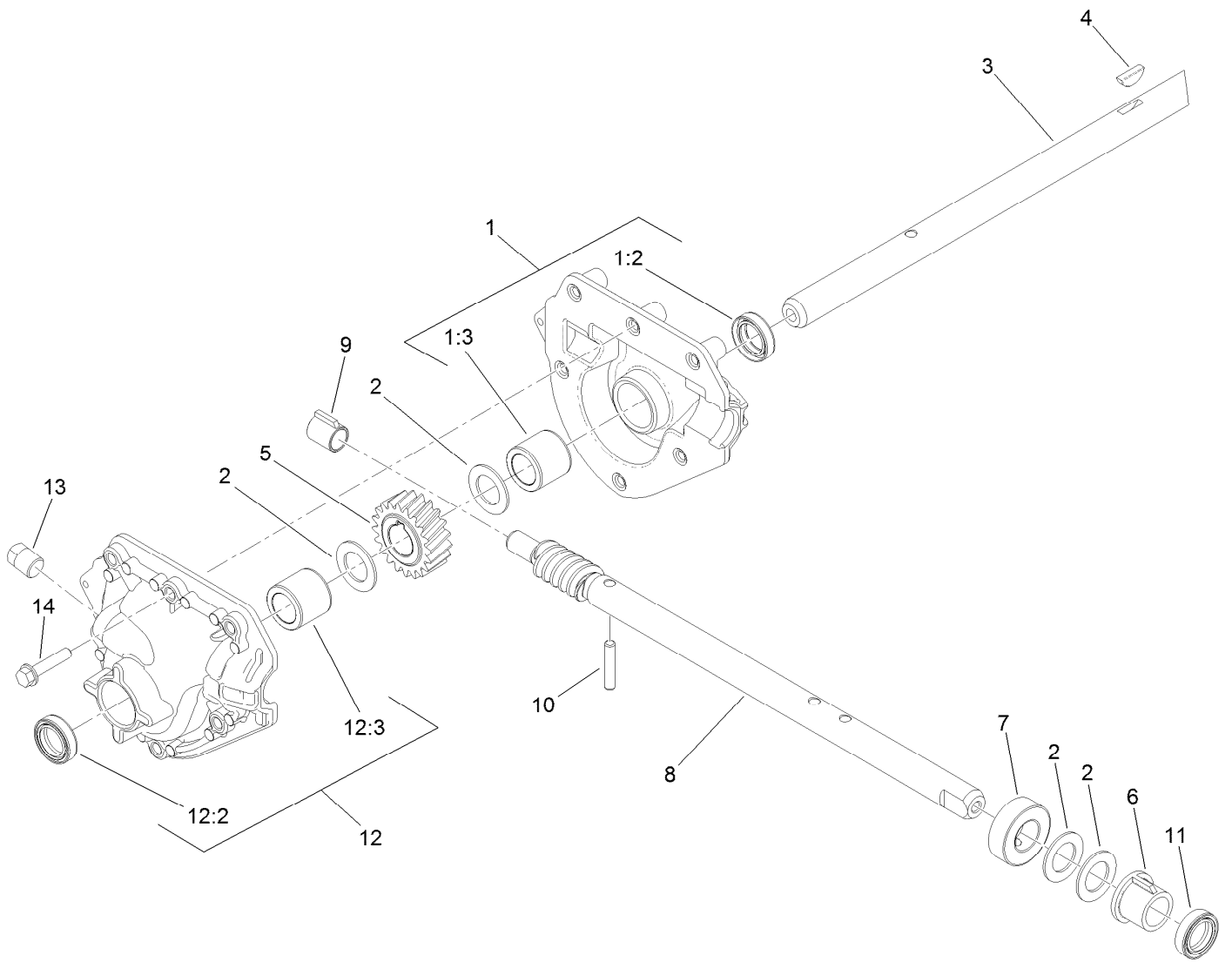

## 26 Inch Auger Gearcase Assembly No. 119-7641

<i>Ref.</i>	<i>Part Number</i>	<i>Qty.</i>	<i>Description</i>	<i>Ref.</i>	<i>Part Number</i>	<i>Qty.</i>	<i>Description</i>
1	121-1209	1	RH Auger Gearcase ASM	8	121-1234	1	Shaft-Impeller, Rolled
1:2	121-6634	1	Seal-Shaft	9	62-1150	1	Bushing-Worm
1:3	120-9269	1	Bushing-Sleeve	10	107-8899	1	Pin-Dowel
2	119-7640	4	Washer-Thrust	11	121-6634	1	Seal-Shaft
3	119-7639	1	Shaft-Output, Auger	12	121-1210	1	LH Auger Gearcase ASM
4	3257-5	1	Key-Woodruff	12:2	121-6634	1	Seal-Shaft
5	119-1576	1	Gear-Helical, 20 Tooth	12:3	120-9269	1	Bushing-Sleeve
6	119-7635	1	Bushing-Input	13	121-6832	1	Plug-Pipe, SQH
7	119-7636	1	Collar-Thrust	14	108-4862	6	Screw-HWHTF

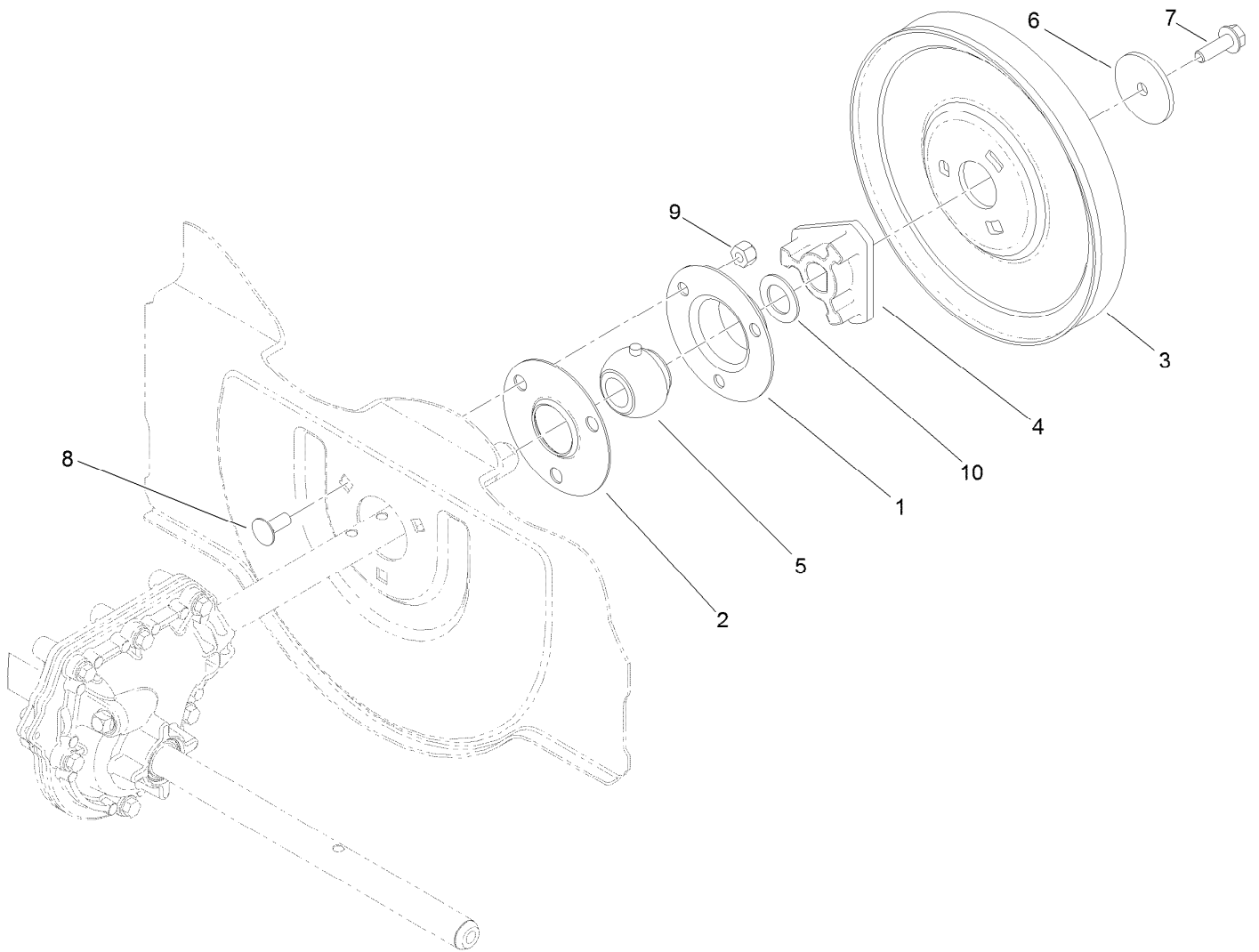

## Impeller Assembly

<b>Ref.</b>	<b>Part Number</b>	<b>Qty.</b>	<b>Description</b>
1	26-6110	1	Flange-Cup, Bearing
2	26-6120	1	Flange-Cup, Bearing
3	120-9263	1	Pulley-Impeller
4	120-9264	1	Hub-Impeller, Pulley
5	120-9272	1	Bearing
6	121-1230	1	Washer-Plain
7	115-5142	1	Screw-HHF
8	3230-23	3	Screw-CARR
9	3296-29	3	Nut-Lock, NI
10	119-7640	1	Washer-Thrust

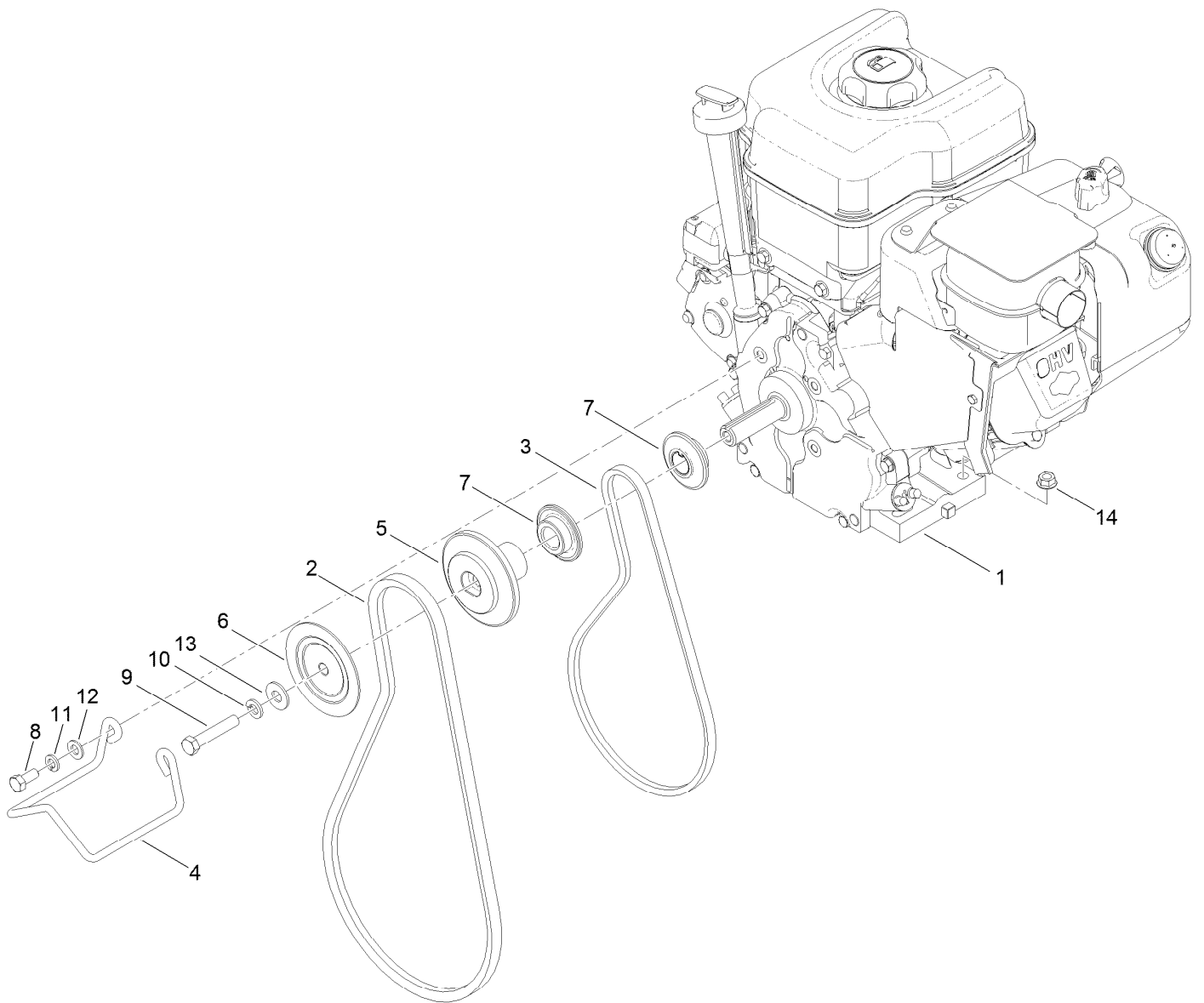

## Engine Assembly

Ref.	Part Number	Qty.	Description
1		1	Engine-Briggs, 15C1070174F8 ●■
2	120-3892	1	Belt-V
3	120-3893	1	Belt-V
4	120-7196	1	Guide-Belt
5	120-9283	1	Pulley-Auger, Rear
6	120-9284	1	Pulley-Auger, Front
7	121-6804	2	Pulley-Traction
8	3210-3	2	Screw-HH
9	120-2302	1	Screw - HH
10	3253-21	1	Washer-Lock
11	3253-4	2	Washer-Lock
12	3256-23	2	Washer-Flat
13	3256-4	1	Washer-Flat
14	32128-20	4	Nut-HF

● Not serviced separately

■ Obtain parts from [www.briggsandstratton.com](http://www.briggsandstratton.com)

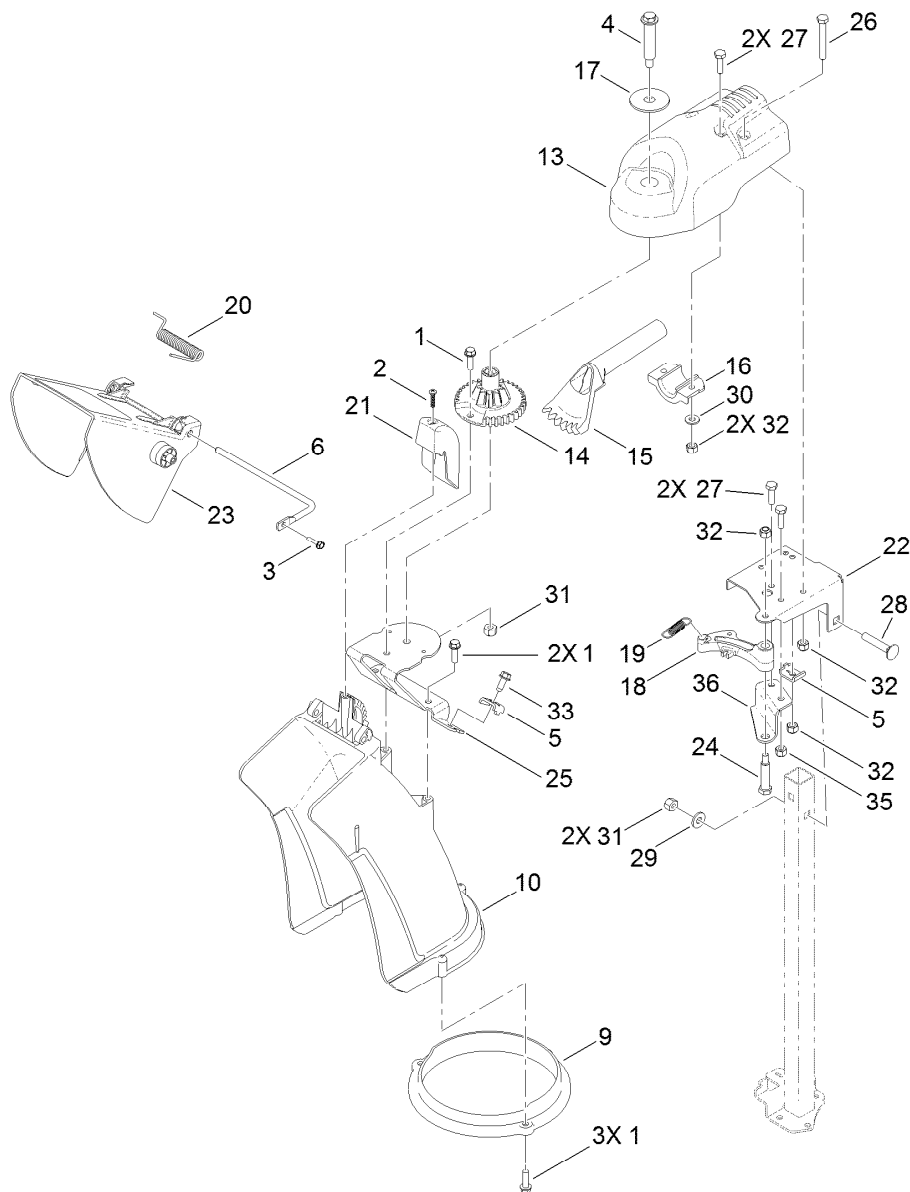

## Chute Assembly

Ref.	Part Number	Qty.	Description	Ref.	Part Number	Qty.	Description
1	46-8091	6	Screw-HWH	21	120-9299	1	Chute-Cover
2	94-4496	1	Screw-PPH	22	121-1207-03	1	Bracket-Support, Chute
3	98-1375	1	Screw-HWH	23	121-1215	1	Deflector-Chute
4	100-9880	1	Bolt-Shoulder	24	121-1229	1	Bolt-Shoulder
5	106-7297	2	Clamp-Cable	25	121-1237-03	1	Bracket-Mount, Chute
6	121-6826	1	Rod-Deflector	26	321-11	3	Screw-HH
9	119-7627	1	Ring-Chute	27	321-5	4	Screw-HH
10	119-7628	1	Chute-Discharge	28	3230-5	2	Screw-CARR
13	120-3852	1	Mount-Chute, Discharge	29	3256-2	2	Washer-Flat
14	120-3853	1	Gear-Chute	30	3256-22	2	Washer-Flat
15	120-3854	1	Gear-Bevel	31	3296-29	3	Nut-Lock, NI
16	120-3855	1	Mount-Gear, Bevel	32	3296-42	5	Nut-Lock, NI
17	120-3856	1	Washer-Flat	33	32144-10	1	Screw-HWH
18	120-3869	1	Latch-Chute	35	3296-42	2	Nut-Lock, NI
19	120-7150	1	Spring-Latch, Chute	36	121-6843	1	Bracket-Support, Latch
20	120-9298	1	Spring-Torsion				

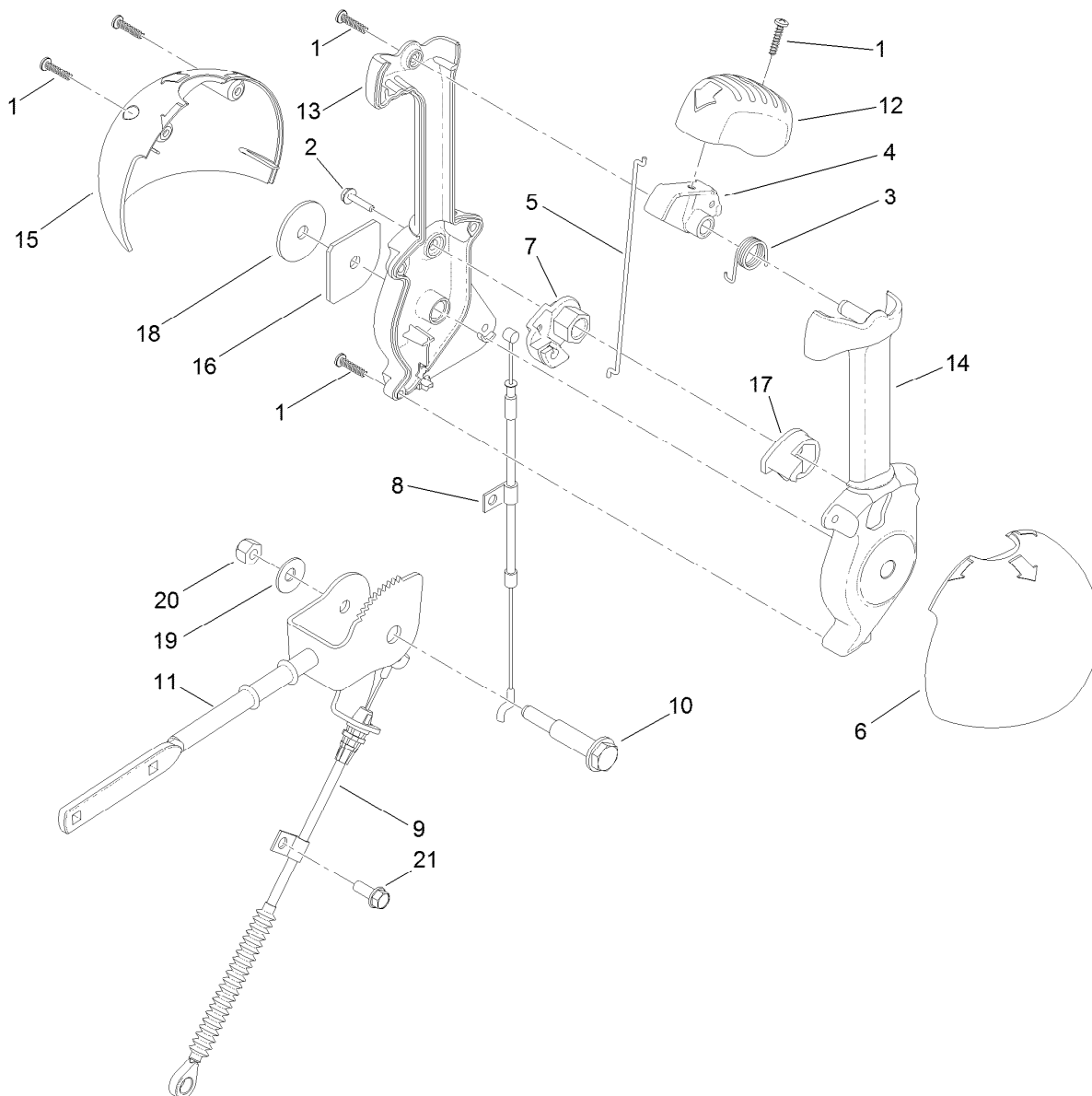

## Quick Stick Assembly

<i>Ref.</i>	<i>Part Number</i>	<i>Qty.</i>	<i>Description</i>	<i>Ref.</i>	<i>Part Number</i>	<i>Qty.</i>	<i>Description</i>
1	94-4496	5	Screw-PPH	12	106-7280	1	Cap-Lever
2	98-1375	1	Screw-HWH	13	106-7281	1	Lever-Chute Control, RH
3	105-9982	1	Spring-Torsion	14	106-7282	1	Lever-Chute Control, LH
4	105-9984	1	Trigger-Latch	15	106-7292	1	Cover-Chute Lever, RH
5	105-9985	1	Link-Latch	16	106-7295	1	Plate-Friction
6	105-9986	1	Cover-Chute Lever, LH	17	106-7310	1	Pawl-Latch
7	105-9988	1	Lever-Cable, Deflector	18	107-3002	1	Washer-Nylon
8	121-6815	1	Cable-Release, Chute	19	3290-456	1	Washer-Belleville
9	121-6839	1	Cable-Deflector, Control	20	3296-29	1	Nut-Lock, NI
10	105-9995	1	Screw-Shoulder	21	32144-85	1	Screw-HWH
11	106-4479	1	Rod-Control, Chute				

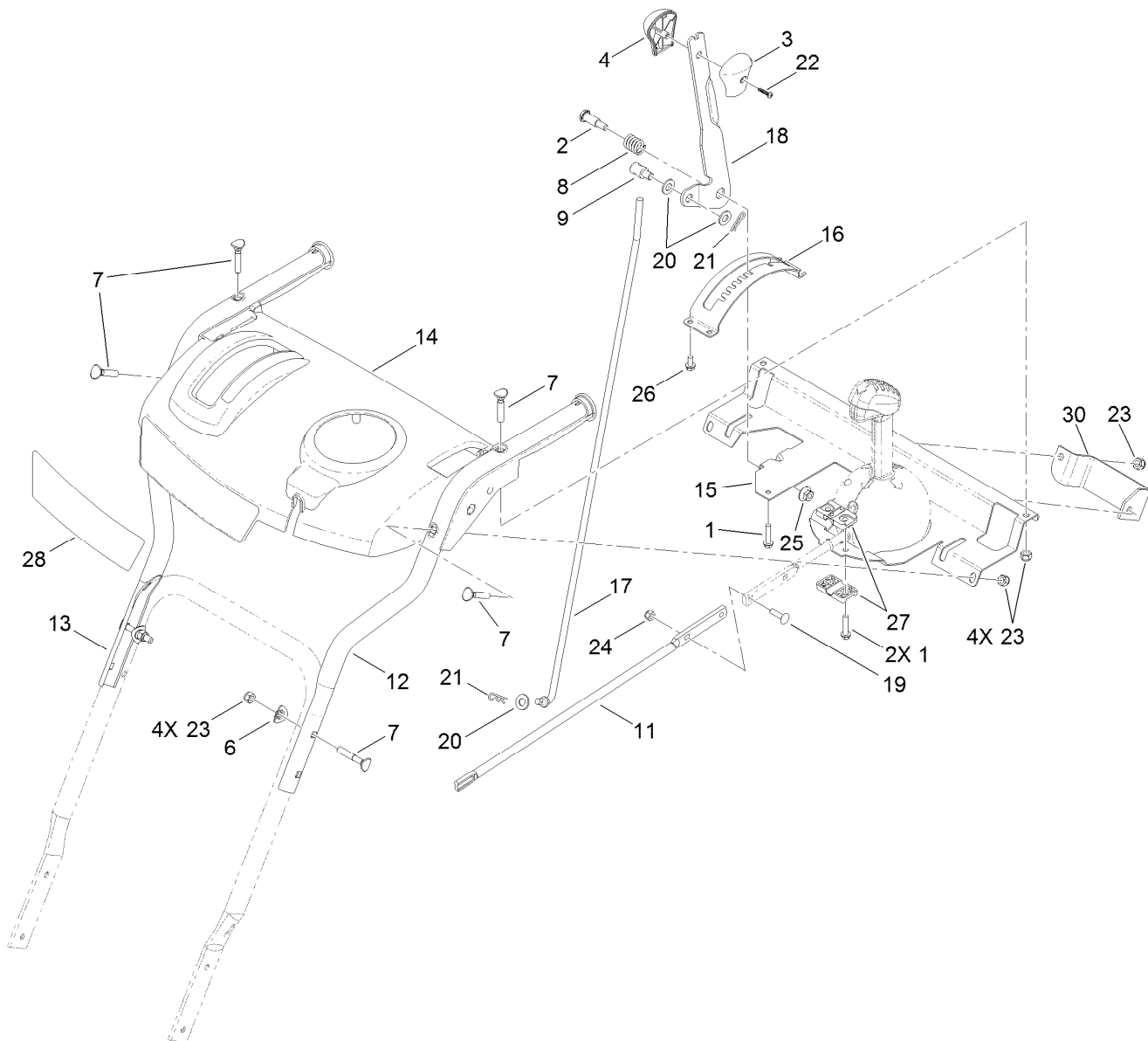

## Handle Assembly

Ref.	Part Number	Qty.	Description	Ref.	Part Number	Qty.	Description
1	46-8092	3	Screw-Plastite	17	121-6829	1	Rod-Selector, Gear
2	63-2650	1	Screw-Shoulder	18	121-1242-03	1	Selector-Speed
3	105-9999	1	Knob-Shift, LH	19	3229-30	2	Screw-CARR
4	106-4423	1	Knob-Shift, RH	20	3256-24	3	Washer-Flat
6	107-3844	4	Washer	21	3290-307	2	Pin-Hair
7	92-2260	8	Screw-Handle	22	94-4496	1	Screw-PPH
8	108-7313	1	Spring-Compression	23	3296-72	8	Nut-Lock, NI
9	110-3446	1	Trunnion-Rod	24	3296-73	2	Nut-Lock, NI
11	120-3881	1	Rod-Chute, Front	25	32128-13	1	Nut-HHF
12	120-7173-03	1	Handle-Upper, LH	26	46-8093	4	Screw-Plastite
13	120-7174-03	1	Handle-Upper, RH	27	105-9987	2	Support-Rod
14	120-7194	1	Panel-Control, Master	28	120-2305	1	Decal-Model
15	120-9251-03	1	Support-Panel, Control	30	120-2301-03	1	Plate-Support, Shift
16	120-9258-03	1	Mount-Selector, Speed				

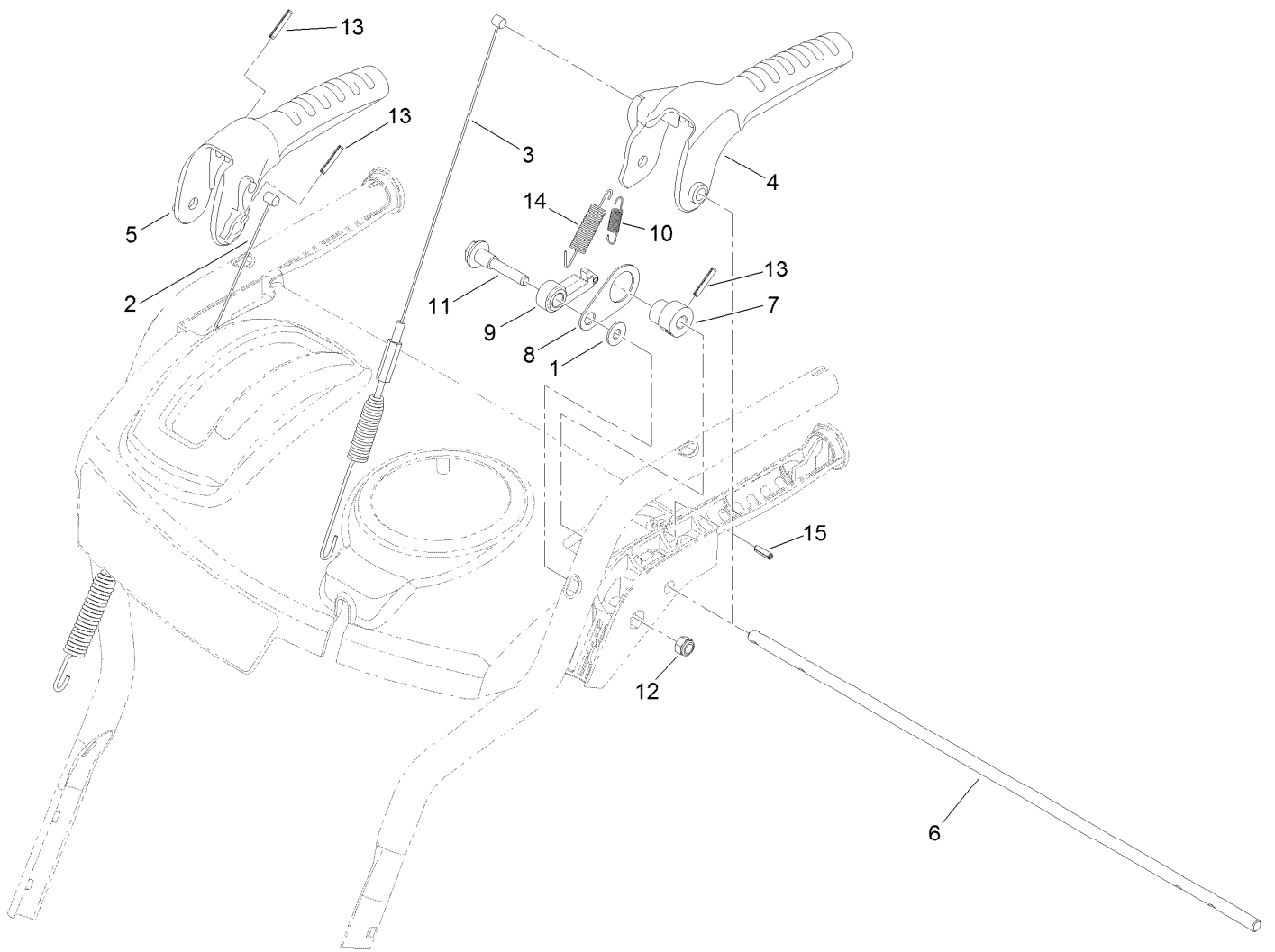

## Control Assembly

Ref.	Part Number	Qty.	Description
1	98-3499	1	Washer-Flat
2	121-6812	1	Cable-Auger
3	121-6813	1	Cable-Traction
4	121-1200	1	Handle-Control, Traction
5	121-1201	1	Handle-Control, Auger
6	121-1202	1	Rod-Lockout
7	121-1203	1	Cam-Lockout
8	121-1204	1	Link-Lockout
9	121-1205	1	Latch-Lockout
10	121-1206	1	Spring-Lockout
11	121-1216	1	Screw-Shoulder
12	3296-72	1	Nut-Lock, NI
13	32121-125	3	Pin-Spring
14	121-1238	1	Spring-Return, Traction Lever
15	32121-2	1	Pin-Roll, Slotted

# Attachments and Accessories

## For 38817 Power Max 826 OE Snowthrower

<b>Product Name</b>	<b>Model/Part</b>
Non-Marking Skid Kit.....	38211
Heavy-Duty Skid Kit.....	38212
Drift Breaker Kit, 24-inch and 26-inch Power Max Snowthrowers.....	38213
Tire Chain Kit, Snowthrowers with 13in Tires .....	38214
Toro 2-Stage Cover.....	490-7466
Plain 2-Stage Cover.....	490-7467



**Notes:**

**Notes:**

**Notes:**



**Count on it.**