



Count on it.

Parts Catalog

**21in Heavy-Duty Recycler®/Rear
Bagger**

Lawn Mower

Model No. 22295—Serial No. 314000001 and Up



Ordering Replacement Parts

To order replacement parts, please supply the part number, the quantity, and the description of each part desired.

Understanding Reference Numbers

Each identified part in an illustration has a reference number. The reference number for a part also appears in the parts list, along with other information about the part.

This catalog uses two special reference number formats, one to indicate parts in a service assembly and another to indicate the quantity of a given part in an illustration.

Service Assembly Reference Numbers

Parts in service assemblies have reference numbers in the form a:b. The a represents the reference number of the entire service assembly and the b represents a sequential number unique to each part within the service assembly.

For example, a wheel assembly might be identified by reference number 6, the tire by 6:1, the valve by 6:2, and the wheel by 6:3. When you order the assembly identified by reference number 6, you receive all parts identified by reference numbers 6:1, 6:2, and 6:3. However, you may also order any part individually. Reference numbers of this type appear in illustration and in parts lists.

Reference Numbers Indicating Quantity

In an illustration, if a reference number indicates more than one part, the reference number has the form nX y. The n represents the quantity of the part, the X is the multiplication symbol, and the y represents the reference number.

For example, in an illustration, the reference number 2X 37 means that two of the parts identified by reference number 37 are indicated.

List of Abbreviations

AR: as required	HLH: hex lag head	PTO: power-take-off
ASM: assembly	HOC: height-of-cut	RH: right hand
BBC: blade brake control	HSBH: hex socket button head	ROPS: roll-over protection system
BHTF: button head thread forming	HSFH: hex socket flat head	RRB: rear roller brush
CARR: carriage	HSH: hex socket head	SFH: slotted fillister head
CCW: counter clockwise	HWH: hex washer head	SHH: slotted hex head
CW: clockwise	HWHTF: hex washer head thread forming	SHWH: slotted hex washer head
DEG: degrees	HYD: hydraulic	SPH: slotted pan head
DPA: Dual Point Adjustment	LH: left hand	SQH: square head
ECM: electronic control module	LP: Liquefied Petroleum Gas	SRH: slotted round head
EXT: external	LPG: Liquefied Petroleum Gas	STD: standard
FH: flat head	NI: nylon insert	TAP: self tapping
GA: gauge	NPTF: national pipe thread fine	TTH: torx truss head
HD: heavy-duty	PFH: phillips flat head	
HF: hex flange	PPH: phillips pan head	
HH: hex head	PPHTF: phillips pan head thread forming	
HHF: hex head flange	PRH: phillips round head	
HHFTF: hex head flange thread forming	PTH: phillips truss head	
HJ: hex jam		

Contents

Housing Assembly	4
Grass Bag Assembly	6
Engine Assembly	8
Fuel Tank Assembly	10
Height-of-Cut and Wheel Assembly	12
Transmission Assembly	14
Handle Assembly	16
Attachments and Accessories	18

Housing Assembly

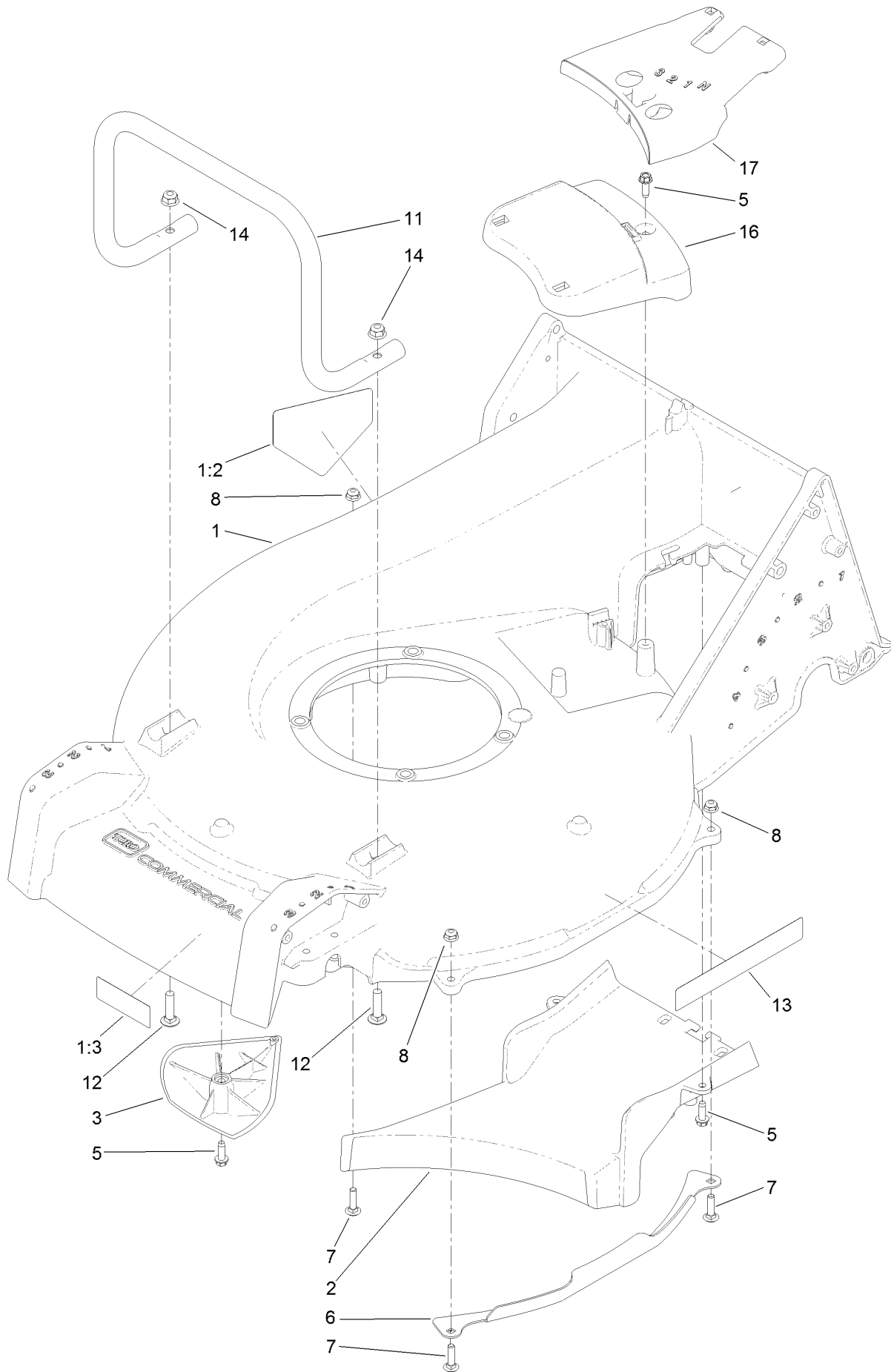

Housing Assembly (continued)

<i>Ref.</i>	<i>Part Number</i>	<i>Qty.</i>	<i>Description</i>	<i>Ref.</i>	<i>Part Number</i>	<i>Qty.</i>	<i>Description</i>
1	125-8400	1	Housing ASM	8	104-7201	4	Nut-HF
1:2	94-8072	1	Decal-Danger	11	125-1003-03	1	Guard-Engine
1:3	68-7410	1	Decal-Blade	12	3230-3	2	Screw-CARR
2	125-1002-01	1	Floor-Chute	13	119-2368	2	Decal-Recycler
3	125-5041	2	Kicker	14	104-8300	2	Nut-Flange, NI
5	49-2040	5	Screw-HWHTF	16	125-5038	1	Cover-Belt, Front
6	125-1047-03	2	Guard-Side, Deck	17	125-5039	1	Cover-Belt, Rear
7	3229-2	4	Screw-CARR				

Grass Bag Assembly

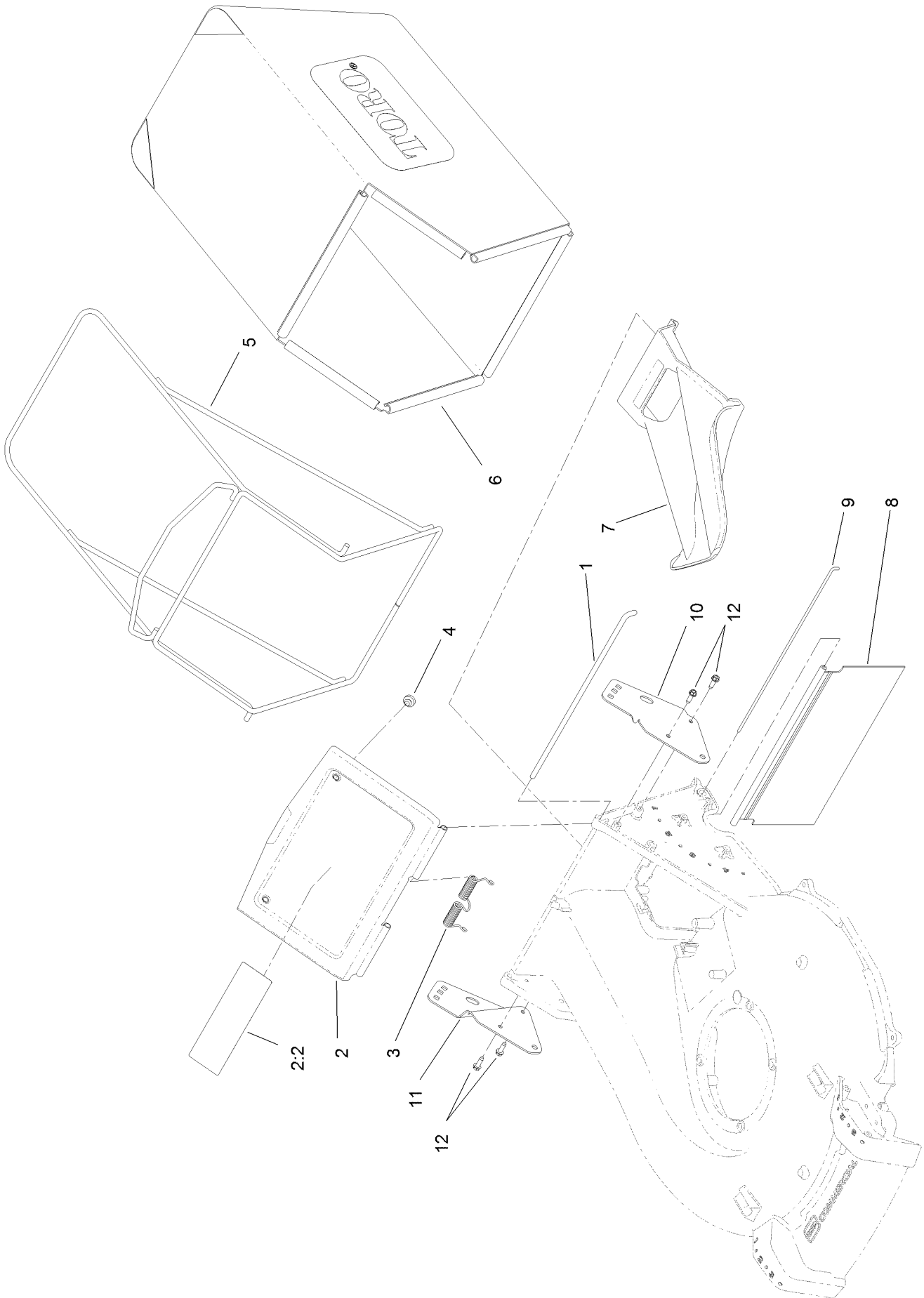

Grass Bag Assembly (continued)

<i>Ref.</i>	<i>Part Number</i>	<i>Qty.</i>	<i>Description</i>	<i>Ref.</i>	<i>Part Number</i>	<i>Qty.</i>	<i>Description</i>
1	125-1017	1	Rod-Door, Bag	7	125-1008	1	Plug-Mulch
2	125-8402	1	Bag Door ASM	8	125-1007	1	Shield-Trailing
2:2	116-7583	1	Decal-Warning	9	125-8413	1	Rod-Shield, Trailing
3	125-1019	1	Spring-Torsion	10	125-1013-03	1	Bracket-Mount, LH Handle
4	1-513658	2	Bumper	11	125-1014-03	1	Bracket-Mount, RH Handle
5	121-1399-03	1	Frame-Bag	12	49-2040	4	Screw-HWHTF
6	125-1030	1	Bag-Grass				

Engine Assembly

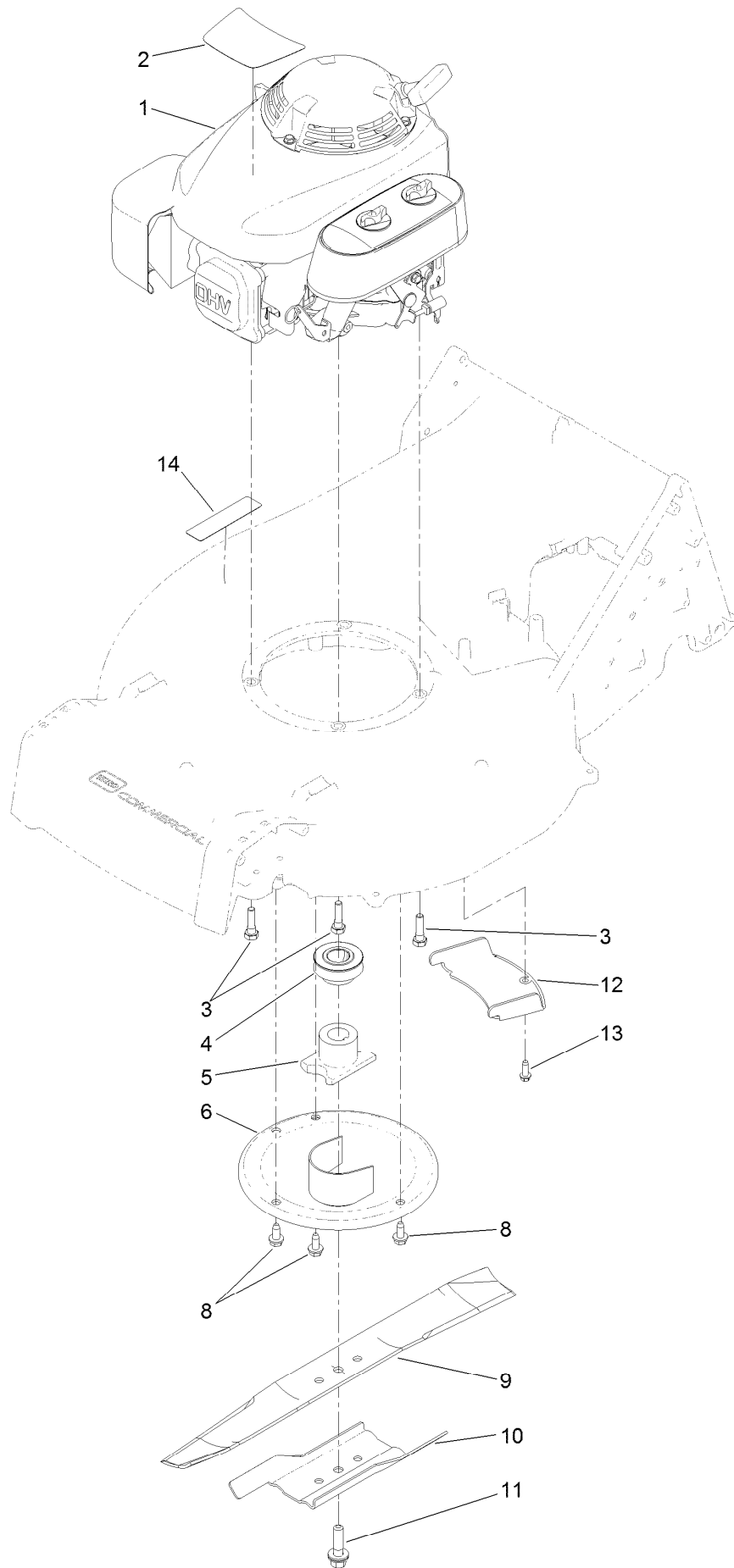

Engine Assembly (continued)

<i>Ref.</i>	<i>Part Number</i>	<i>Qty.</i>	<i>Description</i>	<i>Ref.</i>	<i>Part Number</i>	<i>Qty.</i>	<i>Description</i>
1	119-7831	1	Engine-Honda, Gxv160Uh2 A1Tt	8	32144-70	3	Screw-HWHTF
2	125-8405	1	Decal-Engine, Honda	9	108-3762-03	1	Blade-Recycling
3	125-1074	3	Screw-Hhsh	10	125-1069-03	1	Accelerator-Blade
4	125-8396	1	Pulley-Driver	11	125-2466	1	Bolt-Blade
5	125-1004	1	Driver-Blade	12	125-1024	1	Cover-Belt
6	125-8370	1	Protector-Crankshaft	13	49-2040	1	Screw-HWHTF
				14	117-2718	1	Decal-Arrester, Spark

Fuel Tank Assembly

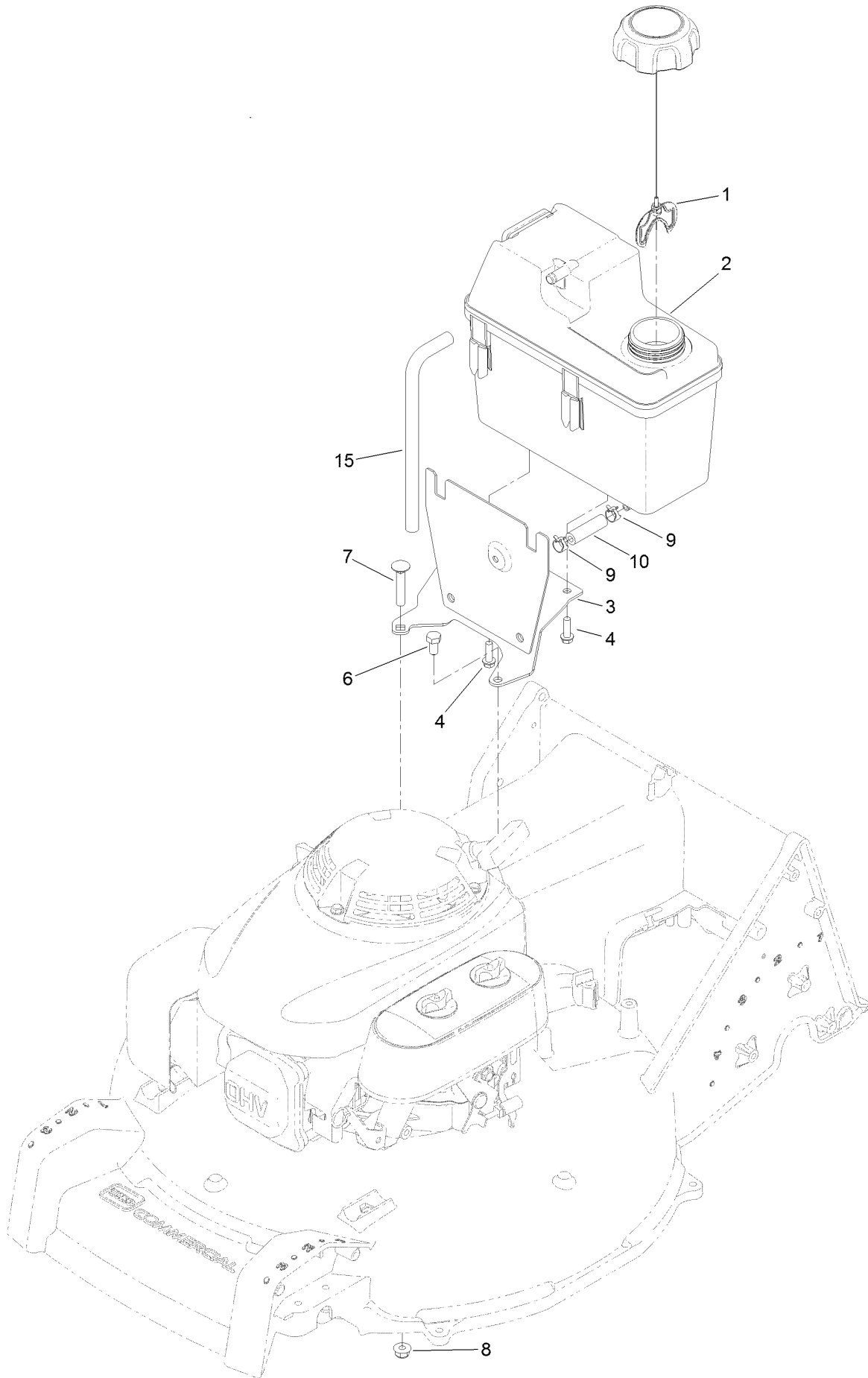

Fuel Tank Assembly (continued)

<i>Ref.</i>	<i>Part Number</i>	<i>Qty.</i>	<i>Description</i>	<i>Ref.</i>	<i>Part Number</i>	<i>Qty.</i>	<i>Description</i>
1	109-6776	1	Cap-Ratchet, Tethered	7	3230-5	1	Screw-CARR
2	114-0280	1	Tank-Fuel	8	104-8300	1	Nut-Flange, NI
3	119-7837-03	1	Mount-Tank	9	2412-98	2	Clamp-Hose
4	46-8091	2	Screw-HWH	10	119-7856	1	Hose-Fuel
6	3210-2	1	Screw-HH	15	115-0962	1	Hose-Vent, Canister

Height-of-Cut and Wheel Assembly

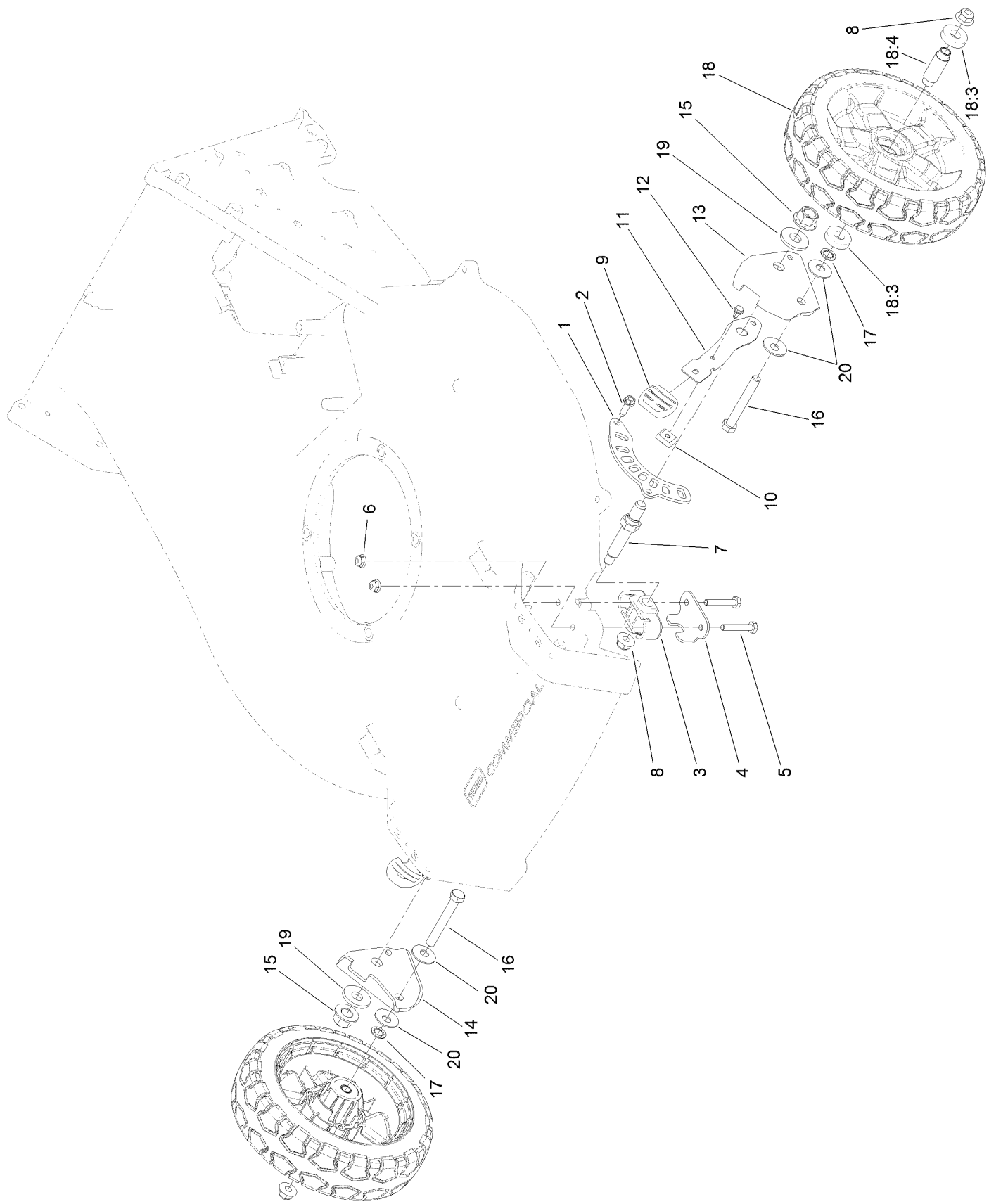

Height-of-Cut and Wheel Assembly (continued)

<i>Ref.</i>	<i>Part Number</i>	<i>Qty.</i>	<i>Description</i>	<i>Ref.</i>	<i>Part Number</i>	<i>Qty.</i>	<i>Description</i>
1	121-1439	2	Plate-HOC, Front	12	104-2065	2	Screw-HWH
2	49-2040	4	Screw-HWHTF	13	121-1425	1	Arm-Pivot, Front LH
3	121-1427	2	Bushing-Axle, Front HOC	14	121-1426	1	Arm-Pivot, Front RH
4	121-1442	2	Retainer-Bushing, Front Axle	15	99-5107	2	Nut-Lock
5	321-9	4	Screw-HH	16	323-13	2	Screw-HH
6	104-7201	4	Nut-HF	17	3254-6	2	Washer-Lock, Internal
7	121-1428	2	Axle-Wheel	18	125-1080	2	Wheel
8	104-8301	4	Nut-Flange, NI	18:3	52-2450	2	Bearing-Wheel
9	125-1093	2	Knob-Lever, HOC	18:4	125-1077	1	Spacer
10	121-1432	2	Key-Arm, Spring	19	1-513435	2	Washer-Spring
11	121-1431	2	Arm-Spring	20	3290-461	4	Washer-Spring

Transmission Assembly

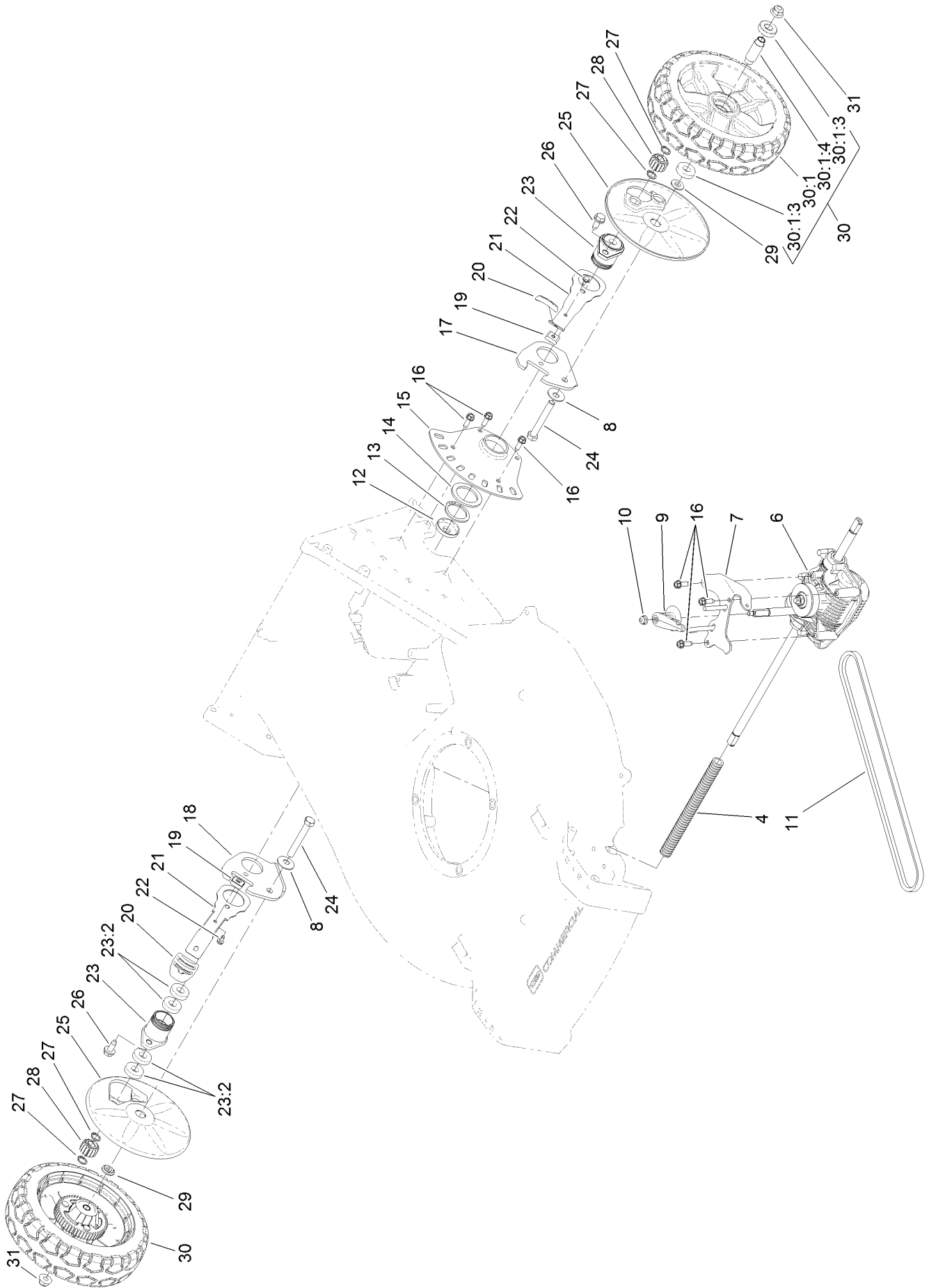

Transmission Assembly (continued)

<i>Ref.</i>	<i>Part Number</i>	<i>Qty.</i>	<i>Description</i>	<i>Ref.</i>	<i>Part Number</i>	<i>Qty.</i>	<i>Description</i>
4	117-5260	1	Cover-Shaft, Drive	21	121-1448	2	Arm-Spring, Rear
6	125-1090	1	Transmission	22	104-2065	2	Screw-HWH
7	125-5090-03	1	Guide-Belt	23	121-1424	2	Retainer ASM
8	3290-461	2	Washer-Spring	23:2	52-2450	4	Bearing-Wheel
9	125-5040	1	Lever-Shift	24	323-13	2	Screw-HH
10	104-7201	1	Nut-HF	25	125-1082	2	Cover-Wheel
11	125-1011	1	Belt-V	26	32144-70	2	Screw-HWHTF
12	127-6848	2	Cover-Bearing	27	32151-61	4	Ring-Retaining
13	32151-10	2	Ring-Retaining	28	110-9417	2	Gear-Pinion, 15T
14	98-1452	2	Washer-Thrust	29	74-1671	2	Spacer-Cover, Wheel
15	121-1447	2	Plate-HOC, Rear	30	125-1081	2	Wheel ASM
16	49-2040	9	Screw-HWHTF	30:1		1	Wheel ●
17	121-1445	1	Arm-Pivot, Rear LH	30:1:3	52-2450	2	Bearing-Wheel
18	121-1446	1	Arm-Pivot, Rear RH	30:1:4	125-1077	1	Spacer
19	121-1432	2	Key-Arm, Spring	31	104-8301	2	Nut-Flange, NI
20	125-1093	2	Knob-Lever, HOC				

● Not serviced separately

Handle Assembly

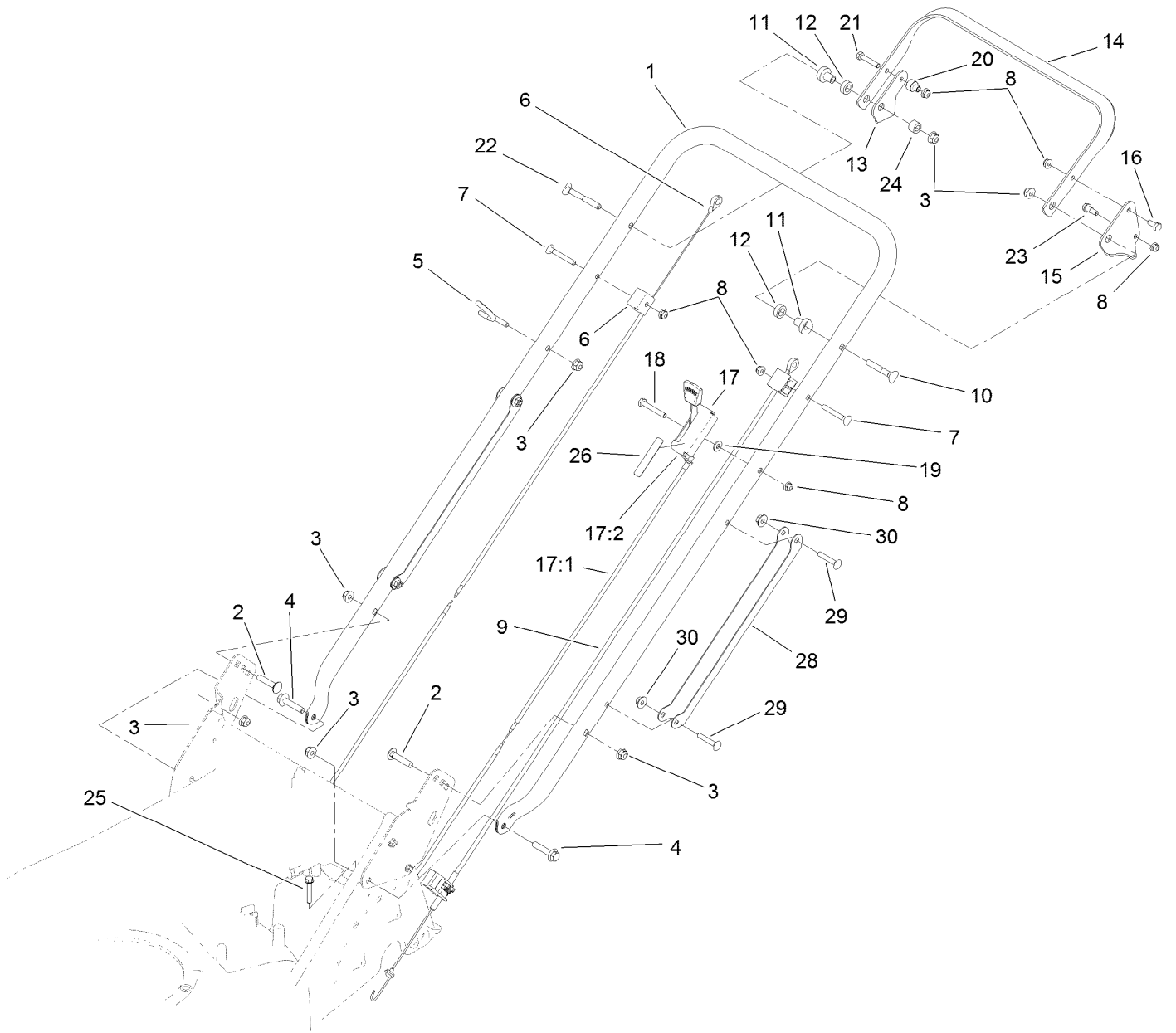

Handle Assembly (continued)

<i>Ref.</i>	<i>Part Number</i>	<i>Qty.</i>	<i>Description</i>	<i>Ref.</i>	<i>Part Number</i>	<i>Qty.</i>	<i>Description</i>
1	125-1016-03	1	Handle	17	125-8374	1	Control-Throttle/Choke
2	3230-4	2	Screw-CARR	17:1	130-6400	1	Cable-Throttle
3	104-8300	7	Nut-Flange, NI	17:2	130-6401	1	Control-Throttle
4	115-1794	2	Screw-HHF	18	321-10	1	Screw-HH
5	116-1056	1	Guide,Rope	19	3256-22	1	Washer-Flat
6	125-8364	1	Cable-Brake	20	125-8433	1	Spacer-Stepped
7	95-4453	2	Screw	21	321-13	1	Screw-HH
8	104-7201	5	Nut-HF	22	125-8408	1	Screw-Handle
9	125-8366	1	Cable-Traction	23	42-3560	1	Bolt-Shoulder
10	17-9428	1	Handle Screw	24	98-4695	1	Spacer
11	49-1630	2	Spacer-Support	25	94-2691	1	Screw-HWH
12	256-276	2	Spacer-Nylon	26	125-8406	1	Decal-Throttle, Choke
13	125-1067-03	1	Lever-Control, Brake	28	127-6897-03	2	Guard-Cable, Handle
14	125-8355-03	1	Bar-Control, Zone Start	29	108-0988	4	Screw-CARR
15	125-1068-03	1	Lever-Control, Traction	30	114-3778	4	Nut-Lock, NI
16	321-3	1	Screw-HH				

Attachments and Accessories

For 22295 21in Heavy-Duty Recycler/Rear Bagger Lawn Mower

Product Name	Model/Part
Blade-21in	108-0954-03
Blade-Bagging, 21in	125-1072-03
Cup-Anti Scalp.....	125-8440

Notes:



Count on it.