



Count on it.

Operator's Manual

**Reelmaster® 6500-D and 6700-D
Traction Unit**

Model No. 03806—Serial No. 313000001 and Up

Model No. 03807—Serial No. 313000001 and Up

Model No. 03808—Serial No. 313000001 and Up

Model No. 03812—Serial No. 313000001 and Up

Model No. 03813—Serial No. 313000001 and Up

This product complies with all relevant European directives, for details please see the separate product specific Declaration of Conformity (DOC) sheet.

WARNING

CALIFORNIA Proposition 65 Warning

Diesel engine exhaust and some of its constituents are known to the State of California to cause cancer, birth defects, and other reproductive harm.

Important: This engine is not equipped with a spark arrester muffler. It is a violation of California Public Resource Code Section 4442 to use or operate the engine on any forest-covered, brush-covered, or grass-covered land. Other states or federal areas may have similar laws.

Introduction

This machine is a ride-on, reel-blade lawn mower intended to be used by professional, hired operators in commercial applications. It is primarily designed for cutting grass on well-maintained lawns in parks, golf courses, sports fields, and on commercial grounds. It is not designed for cutting brush, mowing grass and other growth alongside highways, or for agricultural uses.

Read this information carefully to learn how to operate and maintain your product properly and to avoid injury and product damage. You are responsible for operating the product properly and safely.

You may contact Toro directly at www.Toro.com for product and accessory information, help finding a dealer, or to register your product.

Whenever you need service, genuine Toro parts, or additional information, contact an Authorized Service Dealer or Toro Customer Service and have the model and serial numbers of your product ready. Figure 1 identifies the location of the model and serial numbers on the product. Write the numbers in the space provided.

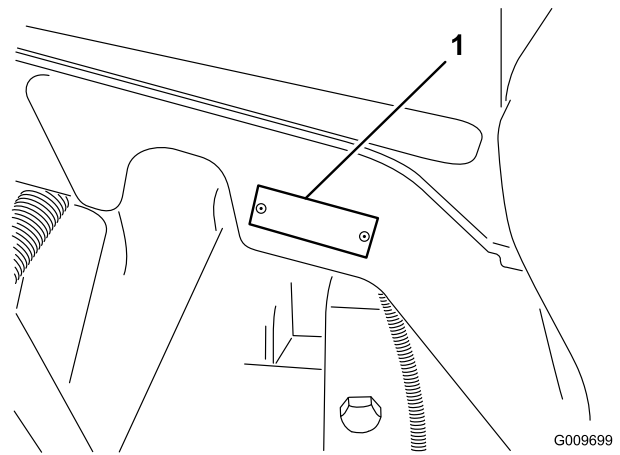

Figure 1

1. Location of the model and serial numbers

Model No. _____
Serial No. _____

This manual identifies potential hazards and has safety messages identified by the safety alert symbol (Figure 2), which signals a hazard that may cause serious injury or death if you do not follow the recommended precautions.



Figure 2

1. Safety alert symbol.

This manual uses two other words to highlight information. **Important** calls attention to special mechanical information and **Note** emphasizes general information worthy of special attention.

Contents

Introduction.....	2	Fuel Lines and Connections.....	42
Safety	4	Fuel Filter/Water Separator	42
Safe Operating Practices	4	Bleeding Air From Injectors	43
Toro Mower Safety	5	Electrical System Maintenance.....	43
Sound Power Level.....	6	Battery Care	43
Sound Power Level.....	6	Fuses.....	44
Sound Pressure Level	6	Optional Lighting.....	44
Vibration Level	6	Drive System Maintenance	46
Safety and Instructional Decals	7	Checking the Torque of the Wheel Nuts or Bolts	46
Setup	14	Checking the Planetary Gear Drive Oil.....	46
1 Checking Fluid Levels.....	14	Changing the Planetary Gear Drive Oil.....	46
2 Installing Cutting UnitsModels 03860, 03861 and 03862.....	14	Checking the Rear Axle Lubricant	47
3 Installing Cutting UnitsModels 03863 and 03864	16	Changing the Rear Axle Lubricant.....	47
4 Making Alternate Cutting Unit Adjustments.....	21	Rear Wheel Toe-In	48
5 Adding Rear Ballast.....	21	Adjusting the Traction Drive for Neutral	48
6 Installing CE Decals	21	Cooling System Maintenance	49
7 Reading the Manuals and Storing Additional Parts.....	21	Removing Debris	49
Product Overview	22	Maintaining the Cooling System.....	49
Controls	22	Brake Maintenance	50
Specifications	25	Adjusting the Service Brakes.....	50
Attachments/Accessories.....	25	Belt Maintenance.....	50
Operation.....	26	Checking the Alternator Belt.....	50
Checking the Engine Oil.....	26	Hydraulic System Maintenance	51
Checking the Cooling System.....	26	Changing the Hydraulic Fluid	51
Filling the Fuel Tank.....	27	Replacing the Hydraulic Filter.....	51
Checking the Hydraulic Fluid.....	29	Checking the Hydraulic Lines and Hoses	51
Checking the Tire Pressure	30	Hydraulic System Test Ports	52
Checking the Reel to Bedknife Contact.....	30	Cutting Unit Maintenance.....	53
Starting and Stopping	30	Cutting Unit KickstandModels 03863 and 03864	53
Bleeding the Fuel System	30	Backlapping.....	53
Pushing or Towing the Machine	31	Adjusting the Cutting Unit Lowering Rate	54
Checking the Interlock Switches	31	Lifted Height of Outer Front Cutting Units (Enable Position).....	55
Fault Memory and Retrieval	33	Adjusting the Travel of the Front Three Cutting Units.....	56
Hydraulic Solenoid Valve Functions.....	33	Storage.....	57
Operating Tips	34	Traction Unit.....	57
Maintenance.....	35	Engine	57
Recommended Maintenance Schedule(s)	35	Schematics	58
Service Interval Chart.....	36		
Daily Maintenance Checklist.....	37		
Lubrication.....	38		
Greasing the Bearings and Bushings.....	38		
Engine Maintenance.....	40		
Servicing the Air Cleaner	40		
Servicing the Engine Oil and Filter.....	41		
Adjusting Throttle.....	41		
Fuel System Maintenance	42		
Fuel Tank.....	42		

Safety

This machine meets or exceeds CEN standard EN 836:1997, ISO standard 5395:1990, and ANSI B71.4-2004 specifications in effect at the time of production when ballast is added; refer to Adding Rear Ballast in Set Up section.

Note: The addition of attachments made by other manufacturers that do not meet American National Standards Institute certification will cause noncompliance of this machine.

Improper use or maintenance by the operator or owner can result in injury. To reduce the potential for injury, comply with these safety instructions and always pay attention to the safety alert ▲ symbol, which means CAUTION, WARNING, or DANGER-“personal safety instruction.” Failure to comply with the instruction may result in personal injury or death.

Safe Operating Practices

The following instructions are from the CEN standard EN 836:1997, ISO standard 5395:1990, and ANSI B71.4-2004.

Training

- Read the Operator's Manual and other training material. If the operator(s) or mechanic(s) can not read English it is the owner's responsibility to explain this material to them.
- Become familiar with the safe operation of the equipment, operator controls, and safety signs.
- All operators and mechanics should be trained. The owner is responsible for training the users.
- Never let children or untrained people operate or service the equipment. Local regulations may restrict the age of the operator.
- The owner/user can prevent and is responsible for accidents or injuries occurring to himself or herself, other people or property.

Preparation

- Evaluate the terrain to determine what accessories and attachments are needed to properly and safely perform the job. Only use accessories and attachments approved by the manufacturer.
- Wear appropriate clothing including hard hat, safety glasses and ear protection. Long hair, loose clothing or jewelry may get tangled in moving parts.

- Inspect the area where the equipment is to be used and remove all objects such as rocks, toys and wire which can be thrown by the machine.
- Use extra care when handling diesel fuel. It is flammable and vapors are explosive.
Use only an approved container.
- Never remove gas cap or add fuel with engine running. Allow engine to cool before refueling. Do not smoke.
- Never refuel or drain the machine indoors.
- Check that operator's presence controls, safety switches and shields are attached and functioning properly. Do not operate unless they are functioning properly.

Operation

- Never run an engine in an enclosed area.
- Only operate in good light, keeping away from holes and hidden hazards.
- Be sure all drives are in neutral and parking brake is engaged before starting engine. Only start engine from the operator's position. Always use seat belts when ROPS is provided.
- Slow down and use extra care on hillsides. Be sure to travel in the recommended direction on hillsides. Turf conditions can affect the machine's stability. Use caution while operating near drop-offs.
- Slow down and use caution when making turns and when changing directions on slopes.
- Never operate with guards not securely in place. Be sure all interlocks are attached, adjusted properly, and functioning property.
- Do not change the engine governor setting or overspeed the engine.
- Stop on level ground, raise the cutting units, disengage drives, engage parking brake (if provided), shut off engine before leaving the operator's position for any reason including emptying the grass baskets.
- Stop equipment and inspect the machine after striking objects or if an abnormal vibration occurs. Make necessary repairs before resuming operations.
- Keep hands and feet away from the cutting units.
- Look behind and down before backing up to be sure of a clear path.
- Never carry passengers and keep pets and bystanders away.

- Slow down and use caution when making turns and crossing roads and sidewalks. Stop reels if not mowing.
- Do not operate the mower under the influence of alcohol or drugs.
- Lightning can cause severe injury or death. If lightning is seen or thunder is heard in the area, do not operate the machine; seek shelter.
- Use care when loading or unloading the machine into a trailer or truck.
- Use care when approaching blind corners, shrubs, trees, or other objects that may obscure vision.

Maintenance and Storage

- Disengage drives, raise the cutting units, set parking brake, stop engine and remove key. Wait for all movement to stop before adjusting, cleaning or repairing.
- Clean grass and debris from cutting units, drives, mufflers, and engine to help prevent fires. Clean up oil or fuel spillage.
- Let engine cool before storing and do not store near flame.
- Shut off fuel while storing or transporting. Do not store fuel near flames or drain indoors.
- Park machine on level ground. Never allow untrained personnel to service machine.
- Use jack stands to support components when required.
- Carefully release pressure from components with stored energy.
- Disconnect battery before making any repairs. Disconnect the negative terminal first and the positive last. Reconnect positive first and negative last.
- Use care when checking the reels. Wear gloves and use caution when servicing them.
- Keep hands and feet away from moving parts. If possible, do not make adjustments with the engine running.
- Charge batteries in an open well ventilated area, away from spark and flames. Unplug charger before connecting or disconnecting from battery. Wear protective clothing and use insulated tools.
- Keep all parts in good working condition and all hardware and hydraulic fittings tightened. Replace all worn or damaged decals.

Toro Mower Safety

The following list contains safety information specific to Toro products or other safety information that you must know that is not included in the ANSI standards.

This product is capable of amputating hands and feet and throwing objects. Always follow all safety instructions to avoid serious injury or death.

Use of this product for purposes other than its intended use could prove dangerous to user and bystanders.

Operation

- Sit on the seat when starting and operating the machine.
- Always wear substantial shoes. Do not operate the machine while wearing sandals, tennis shoes, or sneakers.
- Wearing safety shoes and long pants is advisable and required by some local ordinances and insurance regulations.
- Handle fuel carefully. Wipe up any spills.
- Check the safety interlock switches daily for proper operation. If a switch should fail, replace the switch before operating the machine.
- Using the machine demands attention. To prevent loss of control:
 - Do not drive close to sand traps, ditches, creeks, or other hazards.
 - Reduce speed when making sharp turns. Avoid sudden stops and starts.
 - When near or crossing roads, always yield the right-of-way.
 - Apply the service brakes when going downhill to keep forward speed slow and to maintain control of the machine.
- Do not touch the engine, muffler, or exhaust pipe while the engine is running or soon after it has stopped because these areas could be hot enough to cause burns.
- If a cutting unit strikes a solid object or vibrates abnormally, stop immediately, turn the engine off, wait for all motion to stop, and inspect the machine for damage. A damaged reel or bedknife must be repaired or replaced before operation is continued.
- Traverse slopes carefully. Do not start or stop suddenly when traveling uphill or downhill.
- The operator must be skilled and trained in how to drive on hillsides. Failure to use caution on slopes or hills may cause loss of control and cause the vehicle to tip or roll, possibly resulting in personal injury

or death. Always use the seat belt and Roll Over Protection System (ROPS) together.

- If the engine stalls or loses headway and cannot make it to the top of a slope, do not turn the machine around. Always back slowly, straight down the slope.
- When a person or pet appears unexpectedly in or near the mowing area, stop mowing. Careless operation, combined with terrain angles, ricochets, or improperly positioned guards can lead to thrown object injuries. Do not resume mowing until the area is cleared.
- Do not park on slopes unless the wheels are chocked or blocked.

Maintenance and Storage

- Make sure all hydraulic line connectors are tight and all hydraulic hoses and lines are in good condition before applying pressure to the system.
- Keep your body and hands away from pin hole leaks or nozzles that eject hydraulic fluid under high pressure. Use paper or cardboard, not your hands, to search for leaks. Hydraulic fluid escaping under pressure can have sufficient force to penetrate the skin and cause serious injury.
- Before disconnecting or performing any work on the hydraulic system, all pressure in the system must be relieved by stopping the engine and lowering the cutting units and attachments to the ground.
- If the engine must be running to perform a maintenance adjustment, keep hands, feet, clothing, and any parts of the body away from the cutting units, attachments and any moving parts. Keep everyone away.
- The engine must be shut off before checking the oil or adding oil to the crankcase.
- If major repairs are ever needed or if assistance is desired, contact an Authorized Toro Distributor.
- To make sure of optimum performance and continued safety certification of the machine, use only genuine Toro replacement parts and accessories. Replacement parts and accessories made by other manufacturers could be dangerous, and such use could void the product warranty.

Sound Power Level

Reelmaster 6500

This unit has a guaranteed sound power level of 101 dBA, which includes an Uncertainty Value (K) of 1 dBA.

Sound power level was determined according to the procedures outlined in EN 11094.

Sound Power Level

Reelmaster 6700

This unit has a guaranteed sound power level of 103 dBA, which includes an Uncertainty Value (K) of 1 dBA.

Sound power level was determined according to the procedures outlined in EN 11094.

Sound Pressure Level

This unit has a sound pressure level at the operator's ear of 90 dBA, which includes an Uncertainty Value (K) of 1 dBA.

Sound pressure level was determined according to the procedures outlined in EN 836.

Vibration Level

Hand-Arm

Measured vibration level for right hand = 0.69 m/s²

Measured vibration level for left hand = 1.04 m/s²

Uncertainty Value (K) = 0.5 m/s²

Measured values were determined according to the procedures outlined in EN 836.

Whole Body

Measured vibration level = 0.55 m/s²

Uncertainty Value (K) = 0.5 m/s²

Measured values were determined according to the procedures outlined in EN 836.

Safety and Instructional Decals



Safety decals and instructions are easily visible to the operator and are located near any area of potential danger. Replace any decal that is damaged or lost.

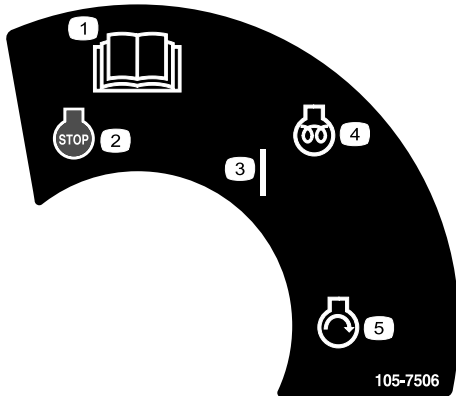

105-7506

1. Read the *Operator's Manual*.
2. Engine—stop
3. On
4. Engine—preheat
5. Engine—start

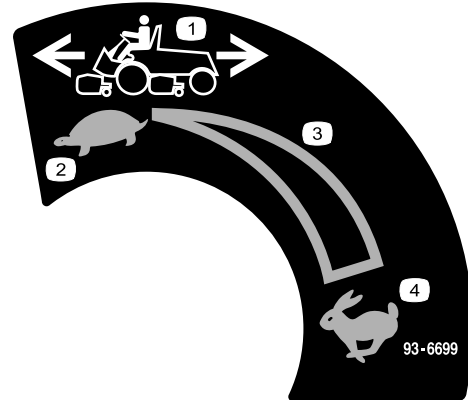

93-6699

1. Machine speed
2. Slow
3. Continuous variable setting
4. Fast

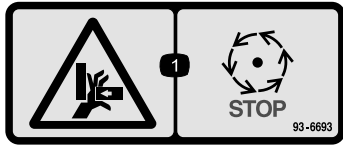

93-6693

1. Crushing hazard of hand—wait for moving parts to stop.

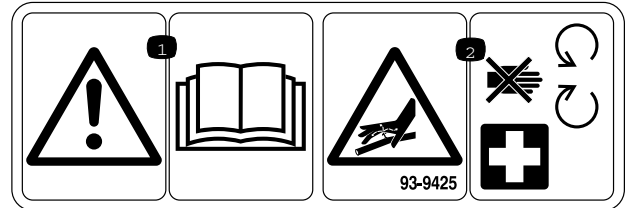

93-9425

1. Read the *Operator's Manual*.
2. Hydraulic hoses are under pressure—stay away from moving parts.

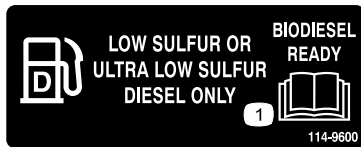

114-9600



93-6696

1. Stored energy hazard—read the *Operator's Manual*.



93-6686

1. Hydraulic oil
2. Read the *Operator's Manual*.



93-6687

1. Do not step here.

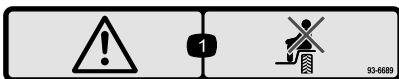

93-6689

1. Danger—do not sit on the plastic shroud.

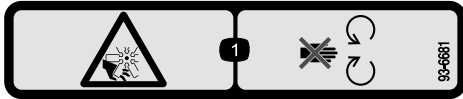

93-6681

1. Cutting/dismemberment hazard—stay away from moving parts.

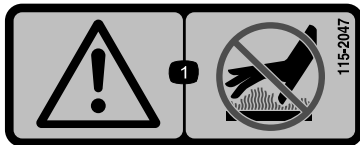

115-2047

1. Warning—do not touch the hot surface.



104-9298

1. Read the *Operator's Manual*.

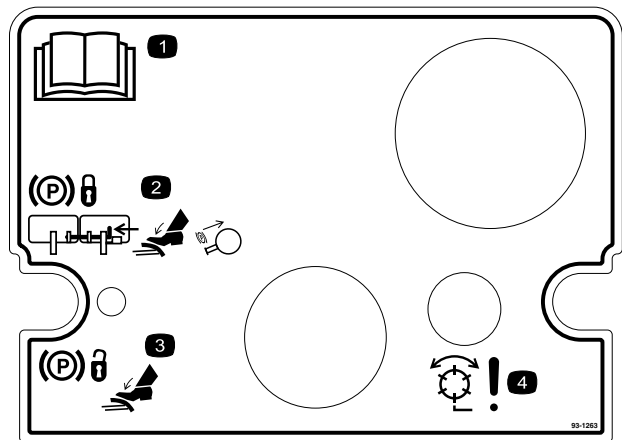

93-1263

1. Read the *Operator's Manual*.
2. To engage the parking brake, connect the brake pedals with the locking pin, push down on both pedals, and pull the brake latch out.
3. To release the parking brake, press both pedals until the parking brake latch retracts.
4. Danger—reels enabled.

REELMASTERS 6500-D / 6700-D

QUICK REFERENCE AID

CHECK/SERVICE (daily)

1. OIL LEVEL, ENGINE
2. OIL LEVEL, HYDRAULIC TANK
3. COOLANT LEVEL, RADIATOR
4. FUEL /WATER SEPARATOR
5. AIR FILTER SERVICE INDICATOR
6. RADIATOR SCREEN
7. BRAKE FUNCTION
8. TIRE PRESSURE (15-20 PSI)

**CHECK/SERVICE
SEE OPERATOR'S MANUAL**

9. BATTERY
10. BELTS (FAN, ALT.)
11. PLANETARY GEAR DRIVE
12. REAR AXLE OIL FILL**
13. REAR AXLE OIL CHECK (2)**

FLUID SPECIFICATIONS/CHANGE INTERVALS

SEE OPERATOR'S MANUAL FOR INITIAL CHANGES.	FLUID TYPE	CAPACITY	CHANGE INTERVAL		FILTER PART NO.
			FLUID	FILTER	
A. ENGINE OIL	SAE 15W-40	7.5 QTS.	150 HRS.	150 HRS.	108-3841
B. HYD. CIRCUIT OIL	MOBIL DTE15M	9 GALS.*	800 HRS.	SEE SERVICE INDICATOR	94-2621
C. PRIMARY AIR FILTER	---	---	---	SEE SERVICE INDICATOR	108-3812
D. SAFETY AIR FILTER	---	---	---	SEE OPERATOR'S MANUAL	108-3813
E. WATER SEPARATOR			400 HRS.		110-9049
F. FUEL TANK	NO. 2-DIESEL	15 GALS.	DRAIN AND FLUSH, 2 YRS.		
G. COOLANT	50/50 ETHELENE GLYCOL / WATER	2.5 GALS.	DRAIN AND FLUSH, 2 YRS.		
H. PLANETARY GEAR DRIVE	SAE85W-140	16 OZ.	800 HRS.	---	---
I. REAR AXLE OIL**	SAE85W-140	80 OZ.	800 HRS.	---	---

* INCLUDES FILTER, CHECK DIP STICK, DO NOT OVER FILL. **4WD ONLY

115-2048

1. Read the *Operator's Manual*.

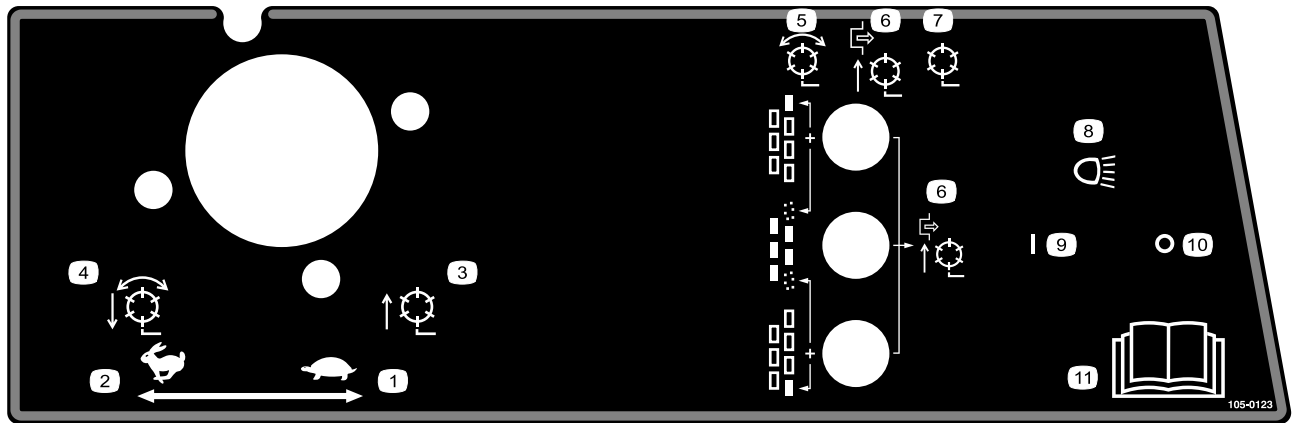

105-0123

Model 03808 and 03813

- | | |
|--|--|
| 1. Throttle—slow | 7. Reels disabled—lift and lower |
| 2. Throttle—fast | 8. Headlights (optional) |
| 3. Reels raised and off | 9. Headlights—On |
| 4. Reels lowered and on when enabled—forward and backlap | 10. Headlights—Off |
| 5. Reels—enabled | 11. Read the <i>Operators Manual</i> . |
| 6. Reels disabled—lift only | |

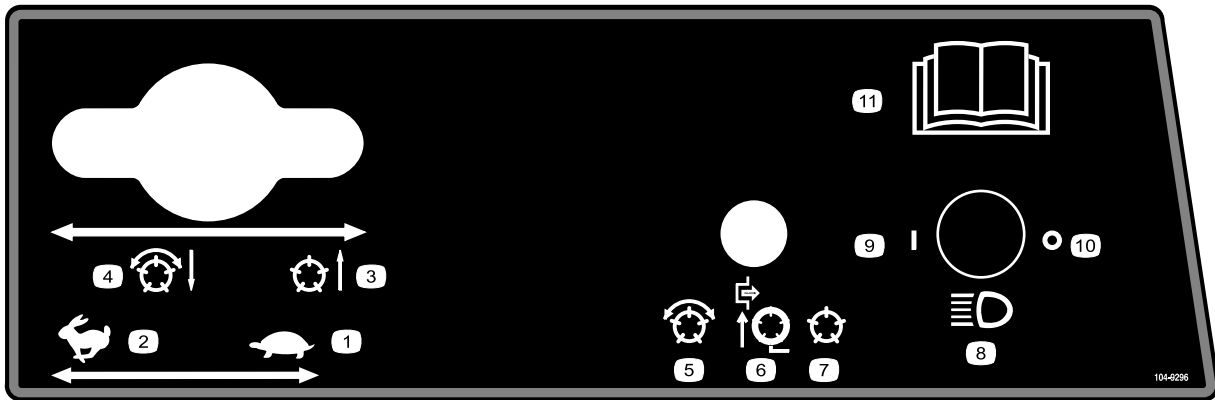

104-9296

Models 03806, 03807 and 03812

- | | | | |
|-------------------------|--|----------------------------------|---|
| 1. Throttle—slow | 4. Reels lowered and on when enabled—forward and backlap | 7. Reels disabled—lift and lower | 10. Headlights—Off |
| 2. Throttle—fast | 5. Reels enabled | 8. Headlights (optional) | 11. Read the <i>Operator's Manual</i> for further instructions. |
| 3. Reels raised and off | 6. Reels disabled—lift only | 9. Headlights—On | |



106-6755

1. Engine coolant under pressure.
2. Explosion hazard—read the *Operator's Manual*.
3. Warning—do not touch the hot surface.
4. Warning—read the *Operator's Manual*.

CALIFORNIA SPARK ARRESTER WARNING

Operation of this equipment may create sparks that can start fires around dry vegetation. A spark arrester may be required. The operator should contact local fire agencies for laws or regulations relating to fire prevention requirements. 117-2718

117-2718

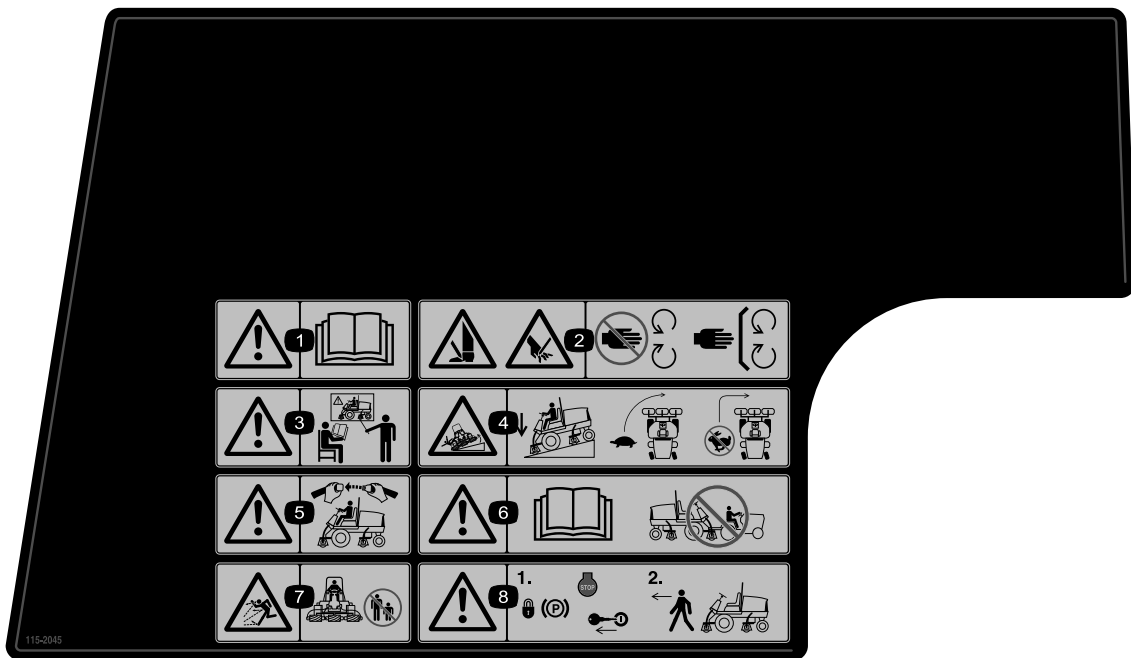

115-2045

1. Warning—read the *Operator's Manual*.
2. Cutting hazard of hand or foot—stay away from moving parts; keep all guards in place.
3. Warning—do not operate this machine unless you are trained.
4. Tipping hazard—lower the cutting unit when driving down slopes; slow machine before turning, do not turn at high speeds.
5. Warning—wear the seat belt when seated in the operator's position.
6. Warning—read the *Operator's Manual*; do not tow the machine.
7. Thrown object hazard—keep bystanders a safe distance from the machine.
8. Warning—lock the parking brake, stop the engine and remove the ignition key before leaving the machine.

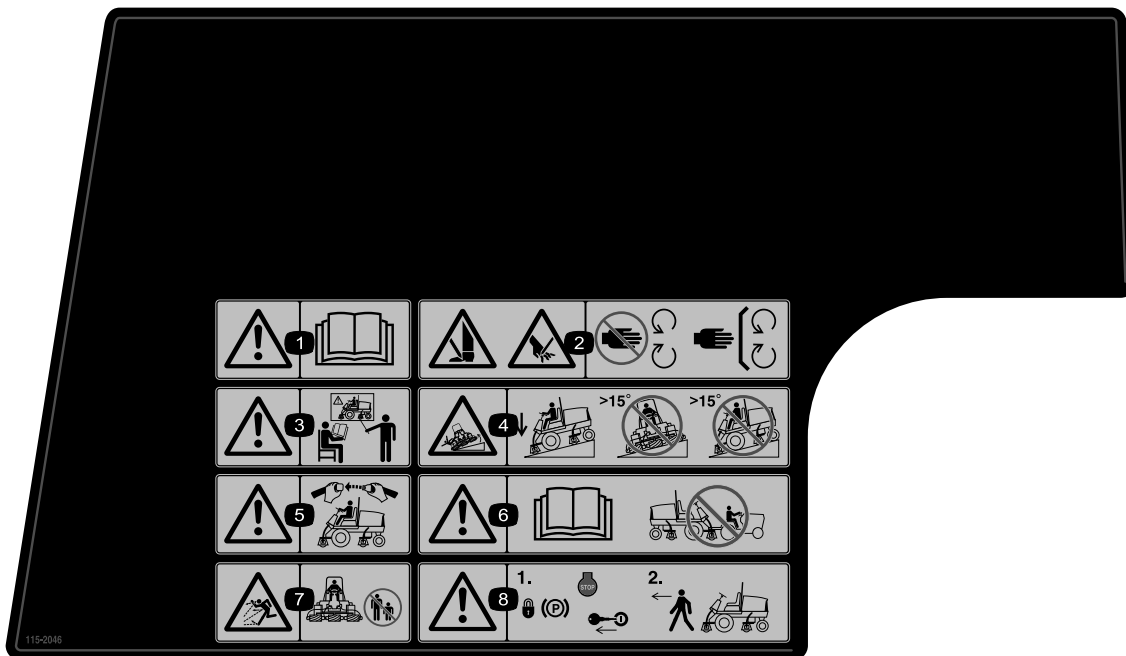

115-2046

(Affix over part no. 115-2045 for CE*)

* This safety decal includes a slope warning required on the machine for compliance to the European Lawn Mower Safety Standard EN836:1997. The conservative maximum slope angles indicated for operation of this machine are prescribed by and required by this standard.

1. Warning—read the *Operator's Manual*.
2. Cutting hazard of hand or foot—stay away from moving parts; keep all guards in place.
3. Warning—do not operate this machine unless you are trained.
4. Tipping hazard—lower the cutting unit when driving down slopes; do not mow on slopes greater than 15 degrees.
5. Warning—wear the seat belt when seated in the operator's position.
6. Warning—read the *Operator's Manual*; do not tow the machine.
7. Thrown object hazard—keep bystanders a safe distance from the machine.
8. Warning—lock the parking brake, stop the engine and remove the ignition key before leaving the machine.

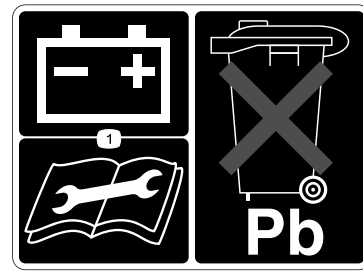
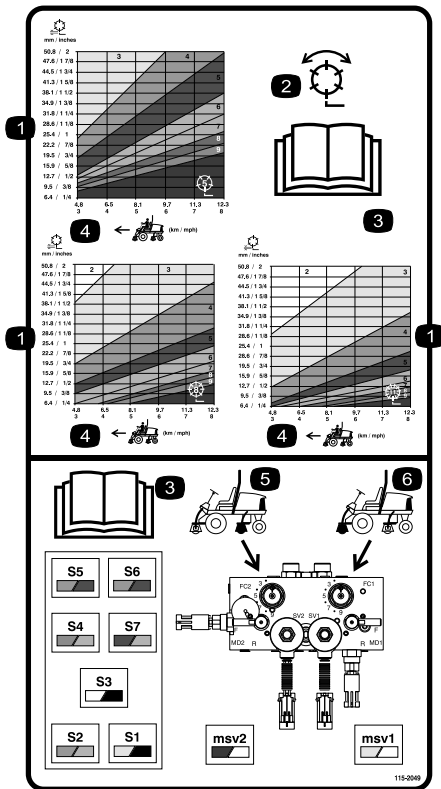

93-6668

1. Read the *Operator's Manual* for information on charging the battery; contains lead; do not discard.

115-2049
Models 03806, 03807 and 03812

1. Reel—height of cut
2. Reel—mow and backlap
3. Read the *Operator's Manual*.
4. Machine speed
5. Rear reels circuit controls
6. Front reels circuit controls

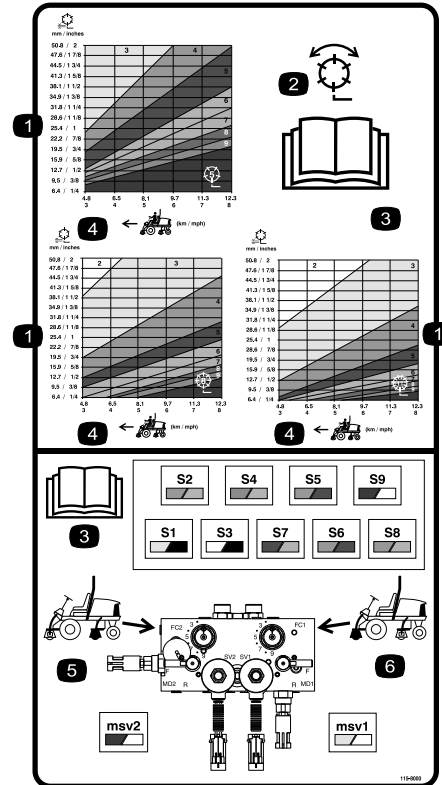

115-8000

Model 03808 and 03813

1. Reel—height of cut
2. Reel—mow and backlap
3. Read the *Operator's Manual*.
4. Machine speed
5. Rear reels circuit controls
6. Front reels circuit controls

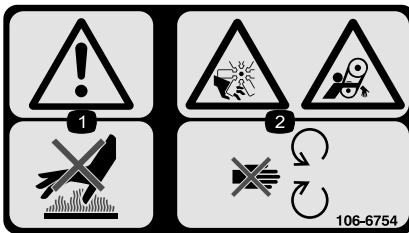

106-6754

1. Warning—do not touch the hot surface.
2. Cutting/dismemberment hazard, fan and entanglement hazard, belt—stay away from moving parts.



Battery Symbols

Some or all of these symbols are on your battery

- | | |
|--|--|
| 1. Explosion hazard | 6. Keep bystanders a safe distance from the battery. |
| 2. No fire, open flame, or smoking. | 7. Wear eye protection; explosive gases can cause blindness and other injuries |
| 3. Caustic liquid/chemical burn hazard | 8. Battery acid can cause blindness or severe burns. |
| 4. Wear eye protection | 9. Flush eyes immediately with water and get medical help fast. |
| 5. Read the <i>Operator's Manual</i> . | 10. Contains lead; do not discard. |
-

Setup

Loose Parts

Use the chart below to verify that all parts have been shipped.

Procedure	Description	Qty.	Use
1	No parts required	–	Check fluid levels.
2	Large O-ring Counter weight Steering locking pin	14/10 7/5 7/5	Install cutting units.
3	Lift chain Chain bracket U-bolt Nut Screw Washer Nut Large O-ring	5/7 5/7 5/7 10/14 5/7 5/7 5/7 5/7	Install cutting units.
4	No parts required	–	Make cutting unit adjustments if needed.
5	Calcium chloride (obtain separately) Rear weight kit, part number 104–1478 (obtain separately)	100lb 1	Add rear ballast (if required).
6	CE decals CE certificate	4 2	Install the CE decals.
7	Operator's Manual Engine Operator's Manual Parts Catalog Operator Training Material Diagnostic ACE display overlay Ignition keys on ring Hood lock key Screw Wing nut	1 1 1 1 1 1 1 2 2	Read the manuals and view the training material before operating the machine.

1

Checking Fluid Levels

No Parts Required

Procedure

Before starting the engine for the first time, check the following fluid levels:

- Engine oil

Refer to Checking the Engine Oil.

- Engine coolant
Refer to Checking the Cooling System.
- Hydraulic oil
Refer to Checking the Hydraulic Oil.
- Rear axle lubricant
Refer to Checking the Rear Axle Lubricant.

2

Installing Cutting Units Models 03860, 03861 and 03862

Parts needed for this procedure:

14/10	Large O-ring
7/5	Counter weight
7/5	Steering locking pin

Mount the Cutting Units

Cutting unit models 03860, 03861, and 03862 can be installed at any of the mounting locations on the traction unit. Figure 3 shows the orientation of the hydraulic drive motor for each of the locations. For any of the locations requiring the motor to be mounted on the right end of the cutting unit, install a counter weight on the left end of the cutting unit. For the locations requiring the motor to be mounted on the left end, install a counter weight on the right end of the cutting unit.

Note: Counterweight mounting capscrews are shipped installed on the right bearing housing of the cutting units. The capscrews on left bearing housing are to be used for securing the hydraulic motor.

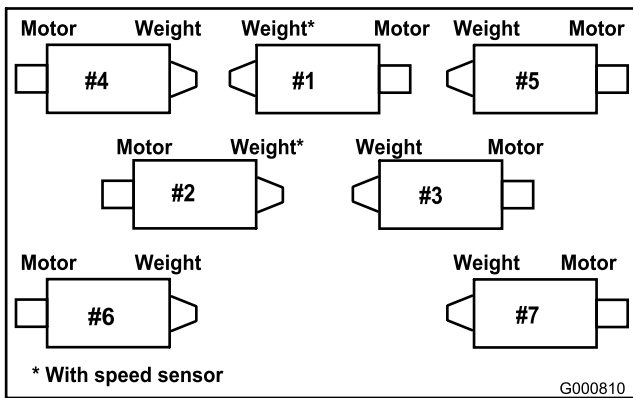

Figure 3

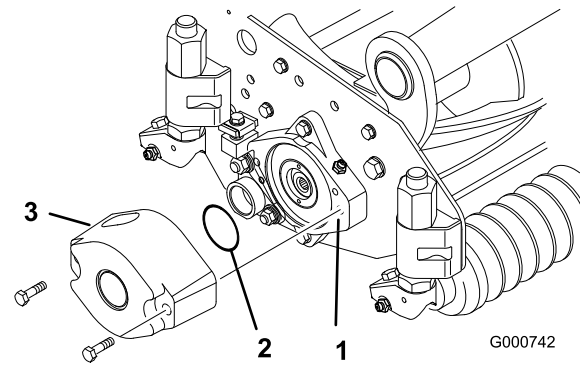

Figure 4

1. Bearing housing
2. Large o-ring
3. Counterweight

Note: Before installing cutting unit motors or counterweights, lubricate internal splines of cutting unit reel shafts with grease.

4. Install a counter weight onto appropriate end of each cutting unit with capscrews provided (Figure 4).
5. Thoroughly grease the cutting unit reel bearings prior to installation on the traction unit. Grease should be evident at the inboard reel seals; refer to *Cutting Unit Operator's Manual* for greasing procedure.
6. Insert a thrust washer onto horizontal shaft of pivot knuckle as shown in (Figure 5).

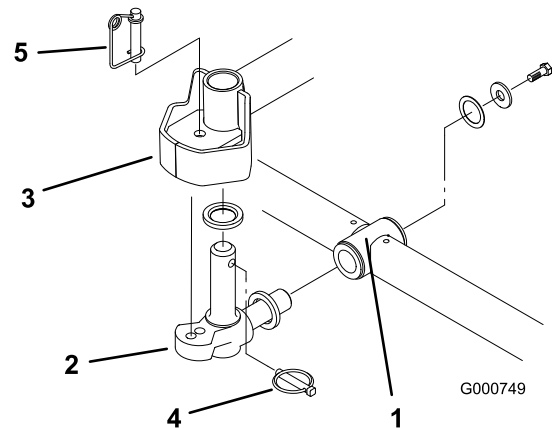

Figure 5

1. Carrier frame
2. Pivot knuckle
3. Lift arm steering plate
4. Lynch pin
5. Steering locking pin

1. Remove cutting units from cartons. Assemble and adjust per *Cutting Unit Operator's Manual*.
2. Remove protective plugs from each end of cutting unit.
3. Lubricate and install a large O-ring into bearing housing groove on each end of cutting unit (Figure 4 & Figure 7).

7. Insert the horizontal shaft of the pivot knuckle into the mounting tube of the carrier frame (Figure 5).
8. Secure pivot knuckle to carrier frame with a thrust washer, flat washer and a flange head capscrew (Figure 5).
9. Insert a thrust washer onto vertical shaft of pivot knuckle (Figure 5).

- If removed, insert the vertical shaft of the pivot knuckle into lift arm pivot hub (Figure 5). Guide the pivot knuckle in place between the two rubber centering bumpers in the under side of the lift arm steering plate.
- Insert the lynch pin into the cross hole on the pivot knuckle shaft (Figure 5).
- Remove nut securing turf compensation spring mounting bracket to cutting unit stabilizer ear (Figure 6). Insert tipper chain onto capscrew and secure with nut removed.

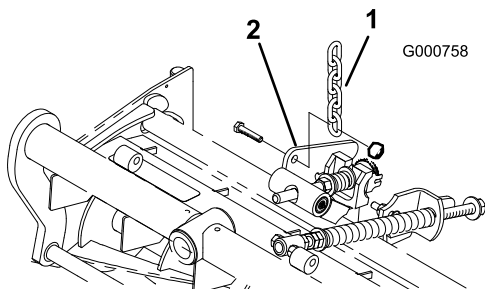

Figure 6

- Lift chain
- Cutting unit stabilizer ear

- Mount the motor to the drive end of the cutting unit and secure with two capscrews provided (Figure 7).

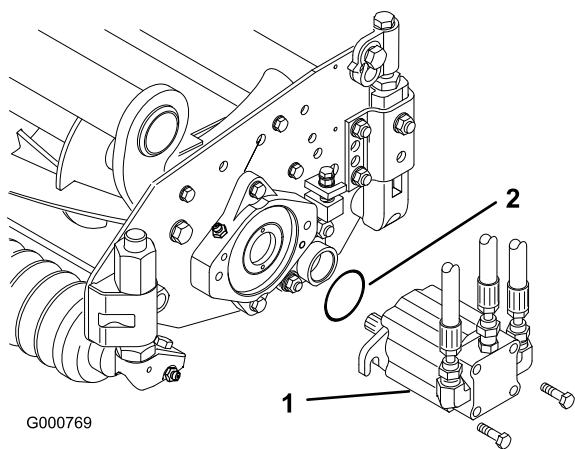

Figure 7

- Motor
- O-ring

Note: If fixed cutting unit position is required, insert steering locking pin into pivot knuckle mounting hole (Figure 5).

- Hook spring wire around bottom of steering locking pin (Figure 5).

Adjust Turf Compensation Spring

Tractors are setup at the factory appropriately for most fairway mowing applications. The following adjustment is for fine-tuning the machine to the application:

The Turf Compensation Spring (Figure 8), connecting carrier frame to cutting unit, controls the amount of fore-aft rotation available, as well as the amount of ground clearance in transport and turn around.

The Turf Compensation Spring also transfers weight from the front to rear roller. This helps to reduce a wave pattern in the turf, also known as bobbing.

Important: Make spring adjustments with cutting unit mounted to traction unit and lowered to shop floor.

- Tighten lock nut on rear of spring rod until the gap (C) between rear of spring bracket and front of washer is 1 in. (25 mm) (Figure 8).

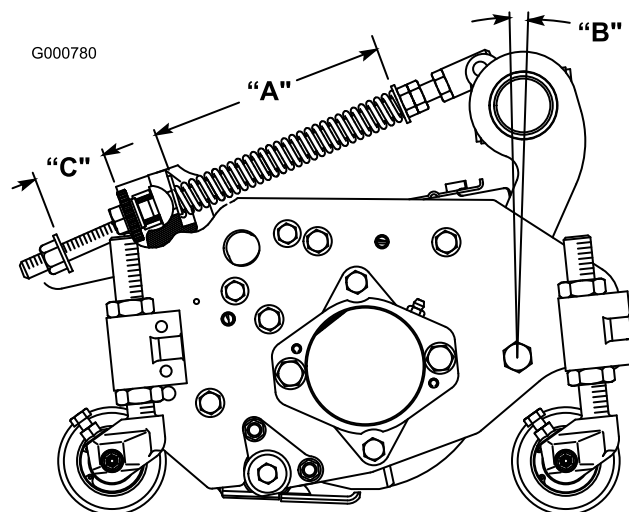

Figure 8

- Tighten hex nuts on front end of spring rod until the compressed length (A) of spring is 8 in. (203 mm) (Figure 8).

Note: When cutting rough or undulating turf, increase compressed length (A) of spring to 8-1/2 in. (216 mm) and gap (C) between rear of spring bracket and front of washer to 1-1/2 in. (38 mm) (Figure 8).

Note: As compressed spring length (A) **decreases**, weight transfer from front roller to rear roller **increases** and carrier frame/cutting unit rotation angle (B) **decreases**.

Note: As gap (C) between spring bracket and washer **increases**, cutting unit ground clearance **decreases** and carrier frame/cutting unit rotation angle (B) **increases**.

3

Installing Cutting Units Models 03863 and 03864

Parts needed for this procedure:

5/7	Lift chain
5/7	Chain bracket
5/7	U-bolt
10/14	Nut
5/7	Screw
5/7	Washer
5/7	Nut
5/7	Large O-ring

Mount the Lift Brackets and Chains

Mount a chain bracket to each lift arm with a U-bolt and 2 nuts. Position the brackets as follows:

- On lift arms #1, #4 and #5, position the chain brackets and U-bolts 15 inches behind the center line of the pivot knuckle (Figure 9). On lift arms #1 and #5 the brackets should be rotated to the right 10 degrees from vertical (Figure 9). On lift arm #4 the bracket should be rotated to the left 10 degrees from vertical (Figure 9).

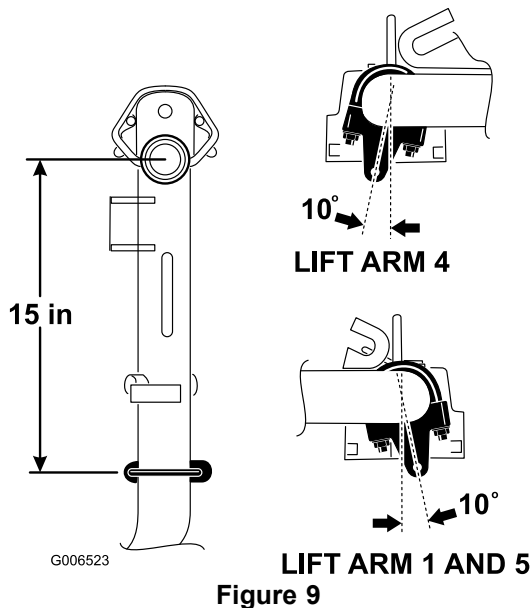

knuckle (Figure 10). Rotate the brackets 45 degrees to the outboard side of the machine.

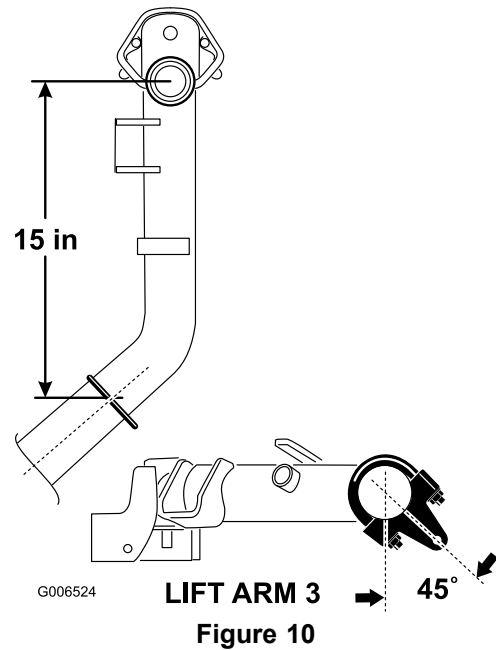

- On lift arms #6 and #7, position the brackets and U-bolts 14.5 inches behind the center line of the pivot knuckle (Figure 11). Rotate the brackets 10 degrees to the outboard side of the machine.

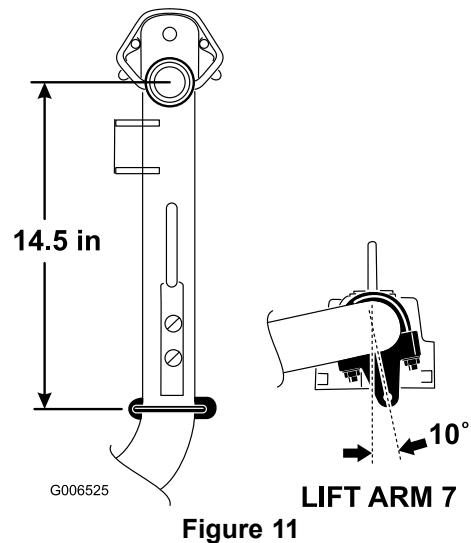

- Tighten all the U-bolt nuts to 38–48 ft-lbs.
- Mount a lift chain to each chain bracket with a screw, washer and nut, positioning as shown in Figure 12

- On lift arms #2 and #3, position the brackets and U-bolts 15 inches behind the center line of the pivot

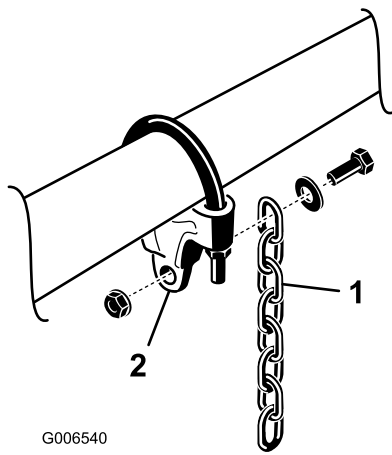

Figure 12

1. Lift chain
2. Chain bracket

Mount the Counter Weights

All cutting units are shipped with the counter weight mounted to the left end of the cutting unit. Use the following diagram to determine the position of the counter weights and reel motors.

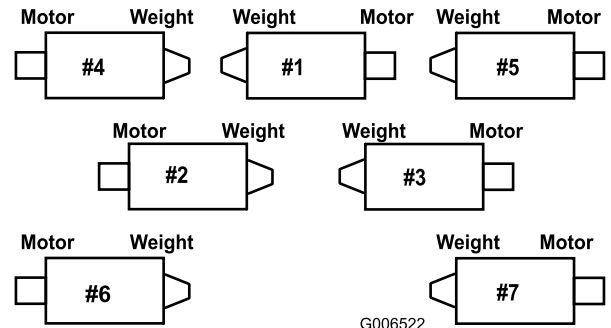

Figure 14

Adjust the Rear Shield

Under most conditions, best dispersion is attained when the rear shield is closed (front discharge). When conditions are heavy or wet, rear shield may be opened.

To open the rear shield (Figure 13), loosen the cap screw securing the shield to the left side plate, rotate the shield to the open position and tighten the cap screw.

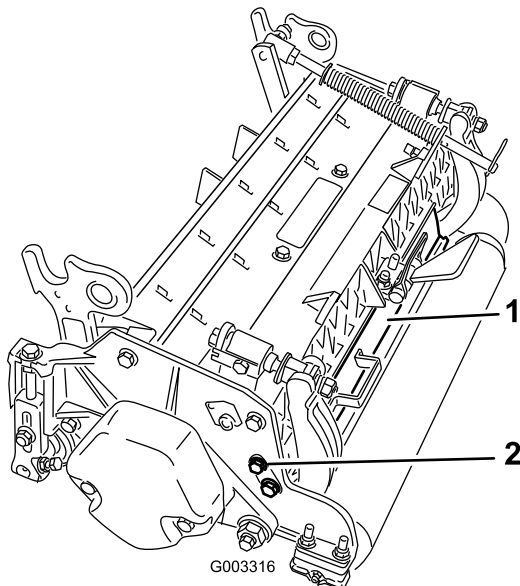

Figure 13

1. Rear shield
2. Cap screw

1. On the #2, #4 and #6 cutting units, remove the 2 cap screws securing the counter weight to the left end of the cutting unit. Remove the counter weight (Figure 15).

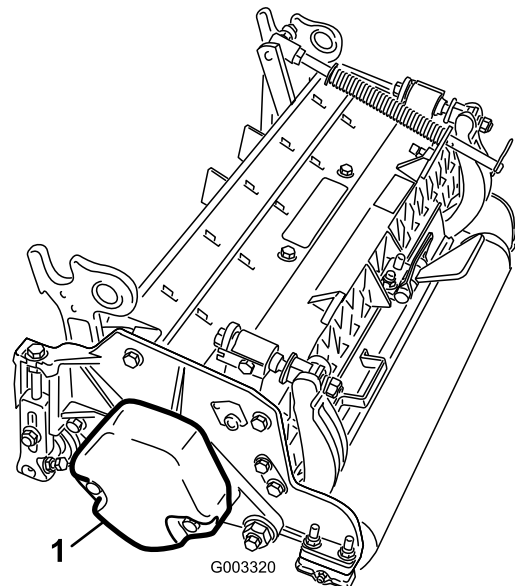

Figure 15

1. Counter weight
2. On right end of cutting unit, remove the plastic plug from the bearing housing (Figure 16).
3. Remove the 2 cap screws from the right side plate (Figure 16).

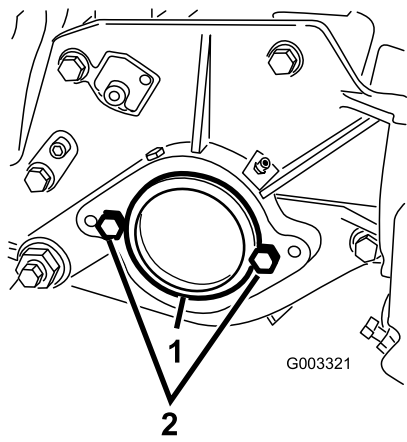

Figure 16

1. Plastic plug
2. Cap screw (2)

4. Install the counter weight to the right end of the cutting unit with the 2 screws previously removed.
5. Loosely install the 2 reel motor mounting cap screws to the left side plate of the cutting unit (Figure 16).

Mount the Cutting Units

1. Insert a thrust washer onto horizontal shaft of pivot knuckle as shown in Figure 17.

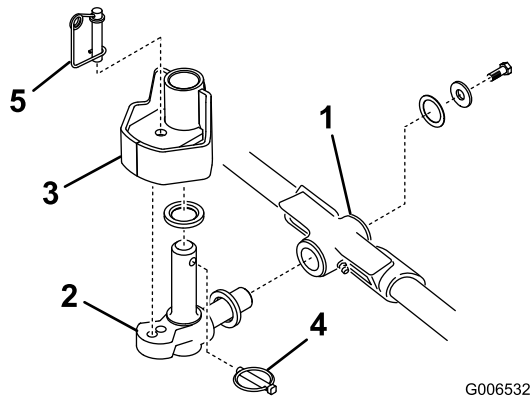

Figure 17

1. Carrier frame
2. Pivot knuckle
3. Lift arm steering plate
4. Lynch pin
5. Steering locking pin

2. Insert the horizontal shaft of the pivot knuckle into the mounting tube of the carrier frame (Figure 17).
3. Secure pivot knuckle to carrier frame with a thrust washer, flat washer and a flange head cap screw (Figure 17).
4. Insert a thrust washer onto vertical shaft of pivot knuckle (Figure 17).
5. If removed, insert the vertical shaft of the pivot knuckle into lift arm pivot hub (Figure 17). Guide

the pivot knuckle in place between the two rubber centering bumpers in the under side of the lift arm steering plate.

6. Insert the lynch pin into the cross hole on the pivot knuckle shaft (Figure 17).
7. Secure the lift arm chain to the cutting unit chain bracket (Figure 18) with the snapper pin as follows:
 - A. On cutting units #1, 4, 5, 6 and 7, only use 6 of the chain links.
 - B. On cutting units #2 and 3, use all 7 of the chain links.

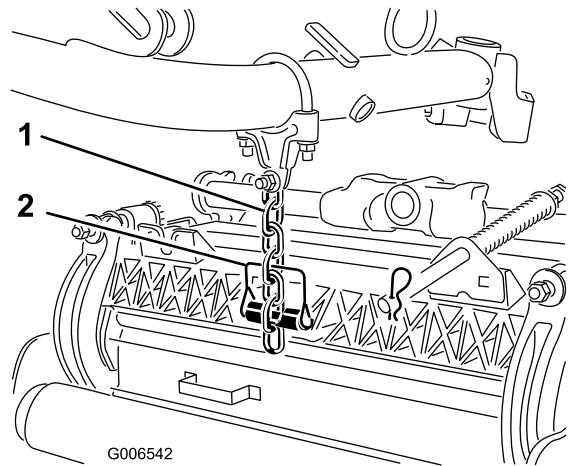

Figure 18

1. Lift chain
2. Snapper pin

8. Coat the spline of the reel motor with clean grease.
9. Oil the reel motor O-ring and install it onto the motor flange.
10. Install the motor by rotating it clockwise so that the motor flanges clear the cap screws (Figure 19). Rotate the motor counterclockwise until the flanges encircle the cap screws then tighten the cap screws

Important: Make sure the reel motor hoses are not twisted, kinked or in the risk of being pinched.

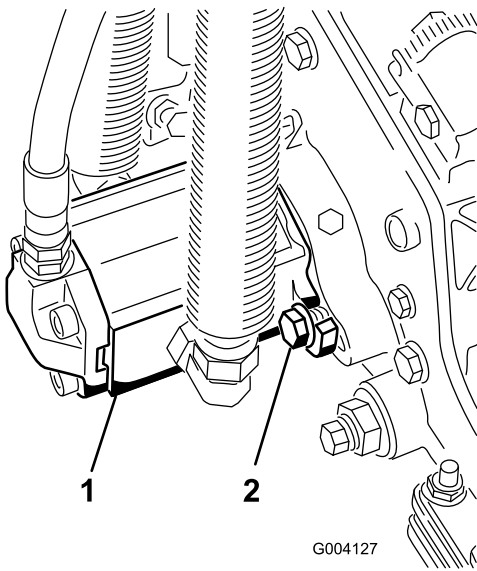

Figure 19

1. Reel drive motor
2. Capscrew

Note: If fixed cutting unit position is required, insert steering locking pin into pivot knuckle mounting hole (Figure 17).

11. Hook spring wire around bottom of steering locking pin (Figure 17).

Adjust the Turf Compensation Spring

Tractors are setup at the factory appropriately for most fairway mowing applications.

The following adjustments are available for fine-tuning of the machine to the application:

The Turf Compensation Spring (Figure 20) transfers weight from the front to rear roller. This helps to reduce a wave pattern in the turf, also known as bobbing.

Important: Make spring adjustments with cutting unit mounted to traction unit and lowered to shop floor.

1. Tighten lock nut on rear of spring rod until the gap (C) between rear of spring bracket and front of washer is 2 in. (51 mm) (Figure 20).

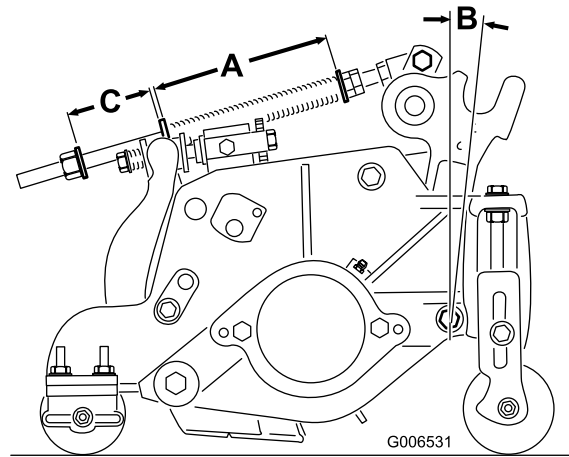

Figure 20

2. Tighten hex nuts on front end of spring rod until the compressed length (A) of spring is 6.25in. (159 mm) (Figure 20).

Note: When operating on rough terrain, decrease the spring length by 1/2 inch. Ground following will be slightly decreased.

Note: As compressed spring length (A) **decreases**, weight transfer from front roller to rear roller **increases** and carrier frame/cutting unit rotation angle (B) **decreases**.

Note: As gap (C) between spring bracket and washer **increases**, cutting unit ground clearance **decreases** and carrier frame/cutting unit rotation angle (B) **increases**.

Note: When cutting undulating turf, increase the compressed spring length (A) and the gap width (C) 1/2 inch (Figure 20).

4

Making Alternate Cutting Unit Adjustments

No Parts Required

Procedure

The factory sets the tractor appropriately for most fairway mowing applications. Several adjustments for fine-tuning the machine for particular applications are included in the Cutting Unit Maintenance section as follows:

- Adjusting the cutting unit lowering rate
Adjusts the speed at which the cutting units lower.
- Adjusting the lifted height of the outer front cutting units
Adjusts the turnaround height of the outer front cutting units to provide greater clearance on contoured fairways.
- Adjusting the travel of the front three cutting units
Adjusts the downward travel of the front three cutting units to allow for highly contoured fairways.

5

Adding Rear Ballast

Parts needed for this procedure:

100lb	Calcium chloride (obtain separately)
1	Rear weight kit, part number 104-1478 (obtain separately)

Procedure

To comply with CEN standard EN 836:1997, ISO standard 5395:1990, and the ANSI B71.4-2004 Standard, add 100 lb (45 kg) of calcium chloride ballast to the rear wheels and install the rear weight kit (Part Number 104-1478).

Important: If a puncture occurs in a tire with calcium chloride, remove unit from turf area as quickly as possible. To prevent possible damage to turf, immediately soak affected area with water.

6

Installing CE Decals

Parts needed for this procedure:

4	CE decals
2	CE certificate

Procedure

If you will be using the machine in a CE country, install the supplied CE decals over the corresponding ANSI decals on the product. Store the CE certificates in a safe location.

7

Reading the Manuals and Storing Additional Parts

Parts needed for this procedure:

1	<i>Operator's Manual</i>
1	<i>Engine Operator's Manual</i>
1	<i>Parts Catalog</i>
1	Operator Training Material
1	Diagnostic ACE display overlay
1	Ignition keys on ring
1	Hood lock key
2	Screw
2	Wing nut

Procedure

1. Read the manuals.
2. View the Operator Training Material.
3. The diagnostic ACE display overlay is for diagnosing machine malfunctions. Store it in a safe location.

Product Overview

Controls

Traction Pedal

The traction pedal (Figure 21) controls forward and reverse operation. Depress top of pedal to move forward and bottom to move backward. Ground speed depends on how far pedal is depressed. For no load, maximum ground speed, fully depress pedal while throttle is in FAST.

To stop, reduce foot pressure on traction pedal and allow it to return to center position.

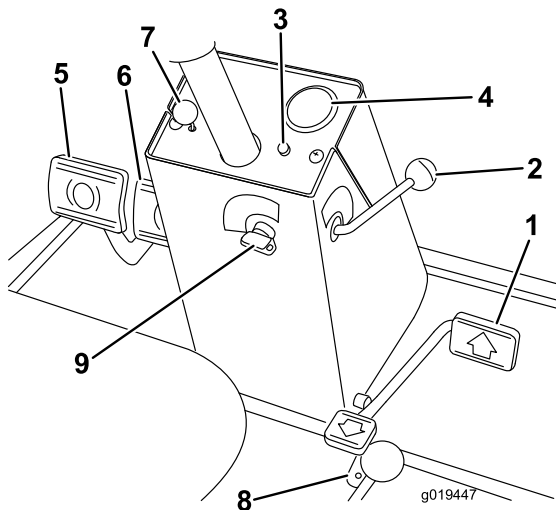

Figure 21

- | | |
|--------------------------|--------------------------|
| 1. Traction pedal | 6. Parking brake latch |
| 2. Forward speed limiter | 7. Locking pin |
| 3. Red diagnostic light | 8. Reverse speed limiter |
| 4. Speedometer | 9. Key switch |
| 5. Brake pedals | |

Forward Speed Limiter

Preset the forward speed limiter (Figure 21) to limit the amount the traction pedal can be depressed in the forward direction to maintain a constant mowing speed.

Red Diagnostic Light

The red diagnostic light (Figure 21), located on steering tower, is used to convey several different messages. While starting the machine, the light will illuminate when the glow plugs are on.

If the light blinks during operation, it may indicate any of the following:

- The machine is being operated faster than the maximum speed value initially programmed into the ECU.
- An electrical malfunction has been detected (open or shorted output).
- A hydraulic leak has been detected (Only if Turfdefender leak detector is installed on machine)
- A communications error has been detected (Only if Turfdefender leak detector is installed on machine)

Key Switch

The key switch (Figure 21) has three positions: OFF, ON/Preheat and START.

Speedometer

The speedometer (Figure 21) indicates ground speed at which machine is traveling.

Brake Pedals

Two brake pedals (Figure 21) operate individual wheel brakes for turning assistance, parking, and to aid in obtaining better sidehill traction. Locking pin connects the pedals for parking brake operation and transport.

Parking Brake Latch

A knob on the left side of console actuates parking brake lock (Figure 21). To engage parking brake, connect pedals with locking pin, push down on both pedals and pull parking brake latch out. To release parking brake, depress both pedals until parking brake latch retracts.

Reverse Speed Limiter

Adjust the screw (Figure 21) to limit the amount the traction pedal can be depressed in the rearward direction to limit speed.

Lower Mow/Raise Control Lever (Joystick)

The lever (Figure 22 and Figure 23) raises and lowers the cutting units and also starts and stops the reels.

Fuel Gauge

The fuel gauge (Figure 22 and Figure 23) indicates level of fuel in tank.

Engine Oil Pressure Warning Light

This light (Figure 22 and Figure 23) indicates dangerously low engine oil pressure.

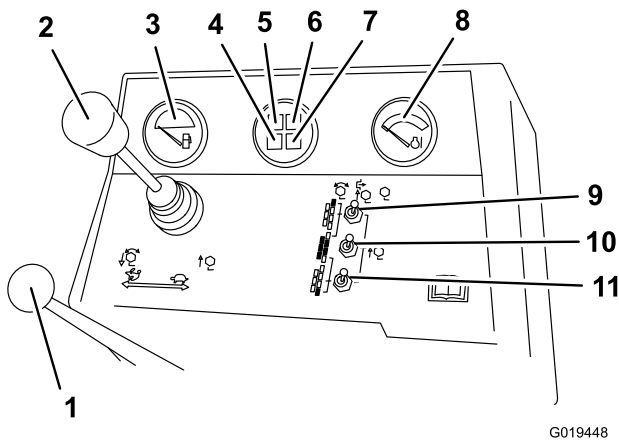

Figure 22
Model 03808 and 03813

- | | |
|---|--|
| 1. Throttle control | 7. Glow plug indicator light |
| 2. Lower mow/raise control lever | 8. Engine coolant temperature gauge |
| 3. Fuel gauge | 9. Enable/disable switch (#7) right rear |
| 4. Charge indicator | 10. Enable/disable switch (Master) |
| 5. Engine oil pressure warning light | 11. Enable/disable switch (#6) left rear |
| 6. Engine coolant temperature warning light | |

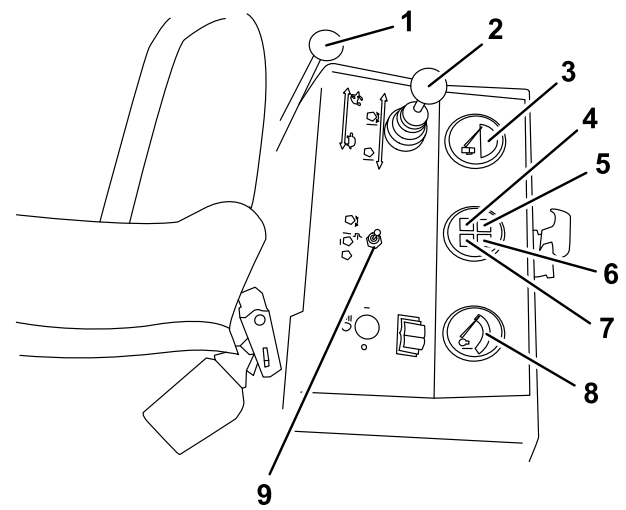

Figure 23
Models 03806, 03807 and 03812

- | | |
|--------------------------------------|---|
| 1. Throttle control | 6. Engine coolant temperature warning light |
| 2. Lower mow/raise control lever | 7. Glow plug indicator light |
| 3. Fuel gauge | 8. Engine coolant temperature gauge |
| 4. Charge indicator | 9. Enable/disable switch (Master) |
| 5. Engine oil pressure warning light | |

Throttle Control

Move the control (Figure 22 and Figure 23) forward to increase engine speed, rearward to decrease speed.

Engine Coolant Temperature Warning Light

The light (Figure 22 and Figure 23) illuminates and the engine shuts down when the coolant reaches a dangerously high temperature.

Glow Plug Indicator Light

When the indicator light (Figure 22 and Figure 23) is lit, indicates glow plugs are on.

Charge Indicator

The charge indicator (Figure 22 and Figure 23) illuminates when system charging circuit malfunctions.

Enable/Disable Switches

The enable/disable switches (Figure 22 and Figure 23) are used in conjunction with the lower mow/raise control lever (Joystick) to operate reels. Reels can be raised but not lowered when in mid position.

Hour Meter

The hour meter (Figure 24) shows total hours that machine has been operated.

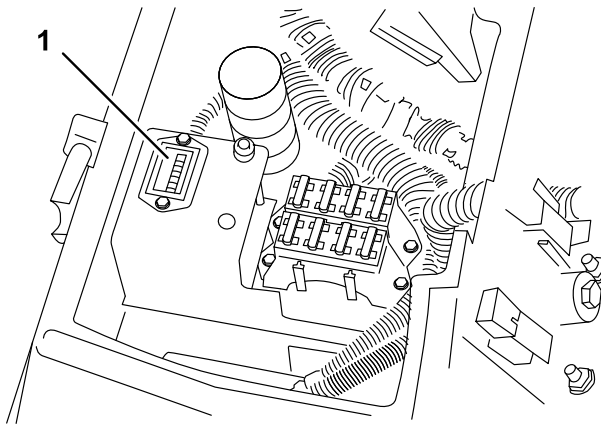

Figure 24

G019525

1. Hour meter

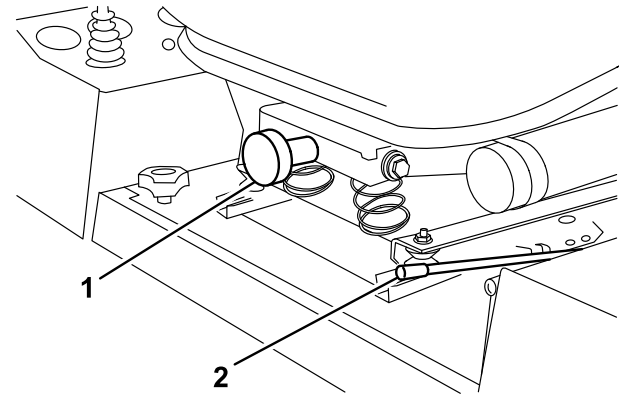

Figure 26

G019451

1. Seat adjusting knob
2. Seat adjusting lever

Backlap Knobs

The backlap knobs (Figure 25) are used in conjunction with lower mow/raise control lever for backlapping operation. Refer to Backlapping in Cutting Unit Maintenance (page 53).

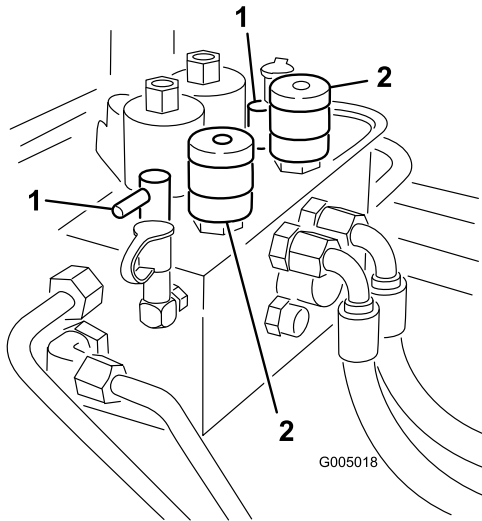

Figure 25

G005018

1. Backlap knobs
2. Reel control knobs

Reel Speed Controls

Controls RPM of front and rear cutting units (Figure 25). #1 position is for backlapping. Remaining settings are for mowing operations. See decal under seat for proper settings.

Seat

The seat adjusting lever (Figure 26) allows 4 inch fore and aft adjustment. The seat adjusting knob (Figure 26)

adjusts seat for operators weight. To adjust seat fore and aft, pull lever on left side of seat assembly outward. After moving seat to desired location, release lever to lock seat into position. To adjust for operators weight, turn spring tension knob; clockwise to increase tension, counterclockwise to decrease spring tension.

Green Diagnostic Light

The machine is equipped with a diagnostic light which indicates if the electronic controller is functioning correctly. The green diagnostic light (Figure 27) is located under the control panel, next to the fuse block. When the electronic controller is functioning correctly and the key switch is moved to the ON position, the controller diagnostic light will be illuminated. The light will blink if the controller detects a malfunction in the electrical system. The light will stop blinking and automatically reset when the key switch is turned to the OFF position.

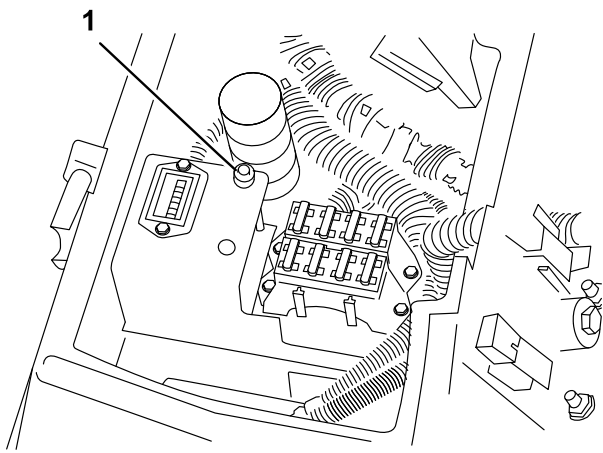

G019452

Figure 27

1. Green diagnostic light

When the controller diagnostic light blinks, one of the following problems has been detected by the controller:

- One of the outputs has been shorted.
- One of the outputs is open circuited.

Using the diagnostic display, determine which output is malfunctioning, refer to Checking Interlock Switches.

If the diagnostic light is not illuminated when the key switch is in the On position, this indicates that the electronic controller is not operating. Possible causes are:

- Loopback is not connected.
- The light is burned out.
- Fuses are blown.
- No battery power.

Check electrical connections, input fuses and diagnostic light bulb to determine malfunction. Make sure loopback connector is secured to wire harness connector.

Diagnostic ACE Display (Optional)

The machine is equipped with an electronic controller which controls most machine functions. The controller determines what function is required for various input switches (i.e. seat switch, key switch, etc.) and turns on the outputs to actuate solenoids or relays for the requested machine function.

For the electronic controller to control the machine as desired, each of the input switches, output solenoids and relays must be connected and functioning properly.

The Diagnostic ACE display is a tool to help the user verify correct electrical functions of the machine.

Specifications

Note: Specifications and design are subject to change without notice.

Width-of-cut, model 03806, 03807 and 03812	96 inches (244 cm)
Width-of-cut, model 03808 and 03813	133 inches (338 cm)
Overall width, Transport	89 inches (226 cm)
Overall width, Operational	110 inches (279 cm)
Overall length	120 inches (305 cm)
Height With ROPS installed	84 inches (213 cm)
Weight*, model 03806	3200 lb (1451 kg)
Weight*, model 03807 and 03812	3300 lb (1496 kg)
Weight*, model 03808 and 03813	3950 lb (1792 kg)
* With 5 blade cutting units and full fluid levels.	

Attachments/Accessories

A selection of Toro approved attachments and accessories is available for use with the machine to enhance and expand its capabilities. Contact your Authorized Service Dealer or Distributor or go to www.Toro.com for a list of all approved attachments and accessories.

Operation

Note: Determine the left and right sides of the machine from the normal operating position.

Checking the Engine Oil

Service Interval: Before each use or daily

The engine is shipped with oil in the crankcase; however, the oil level must be checked before and after the engine is first started.

Crankcase capacity is approximately 7.5 qt. (7 l) with the filter.

Use high-quality engine oil that meets the following specifications:

- API Classification Level Required: CH-4, CI-4 or higher.
- Preferred oil: SAE 15W-40 (above 0°F)
- Alternate oil: SAE 10W-30 or 5W-30 (all temperatures)

Note: Toro Premium Engine oil is available from your distributor in either 15W-40 or 10W-30 viscosity. See the parts catalog for part numbers.

Note: The best time to check the engine oil is when the engine is cool before it has been started for the day. If it has already been run, allow the oil to drain back down to the sump for at least 10 minutes before checking. If the oil level is at or below the “add” mark on the dipstick, add oil to bring the oil level to the “full” mark. **DO NOT OVERFILL.** If the oil level is between the “full” and “add” marks, no oil addition is required.

1. Park machine on a level surface. Release hood latch and open hood (Figure 28).

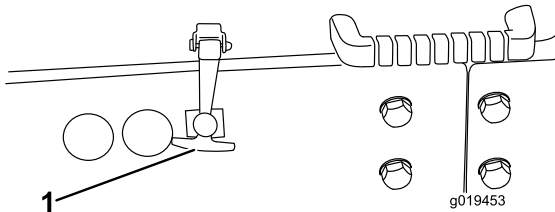

Figure 28

1. Hood latch

2. Remove dipstick (Figure 29), wipe clean and reinstall dipstick. Pull it out again and check oil level on dipstick: Oil level should be up to FULL mark on dipstick.

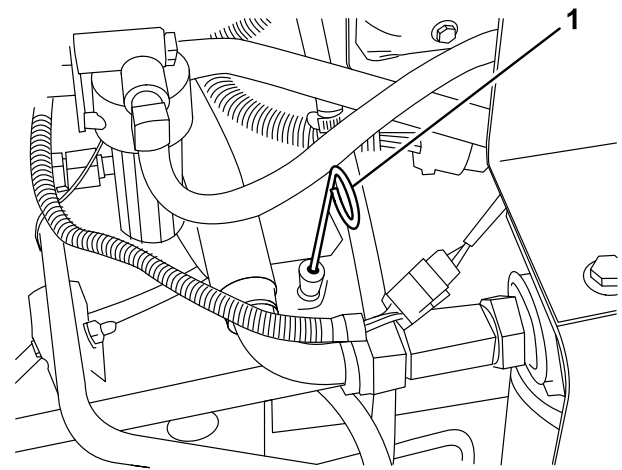

Figure 29

1. Dipstick

3. If oil level is low, remove filler cap (Figure 30) and add oil until level reaches FULL mark on dipstick. Do not overfill.

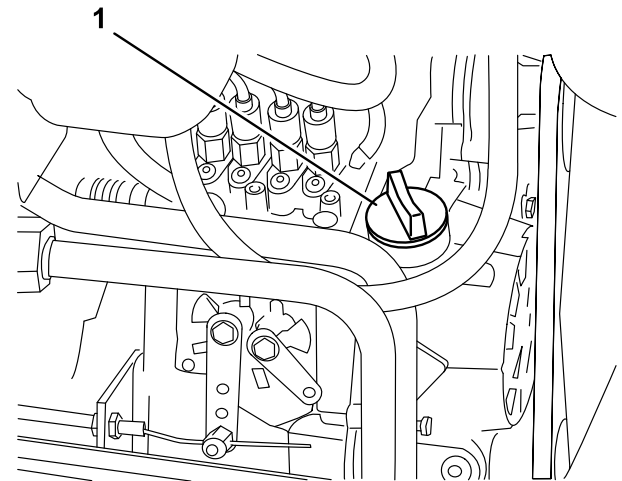

Figure 30

1. Filler cap

4. Install filler cap.
5. Close hood and secure latch.

Checking the Cooling System

Service Interval: Before each use or daily

Clean debris off screen, oil cooler and front of radiator daily, more often if conditions are extremely dusty and dirty; refer to Removing Debris in Cooling System Maintenance (page 49).

The cooling system is filled with a 50/50 solution of water and permanent ethylene glycol antifreeze. Check level of coolant in radiator and expansion tank

at the beginning of each day before starting the engine. Capacity of cooling system is 10 quarts (9.4 l).

⚠ CAUTION

If the engine has been running, pressurized hot coolant can escape and cause burns if the radiator cap is removed.

Allow the engine to cool at least 15 minutes or until the radiator cap is cool enough to touch without burning hands.

1. Carefully remove radiator cap and expansion tank cap (Figure 31).
2. Check level of coolant in radiator and in expansion tank (Figure 31).

Radiator should be filled to the top of the filler neck and the expansion tank filled to the Full mark.

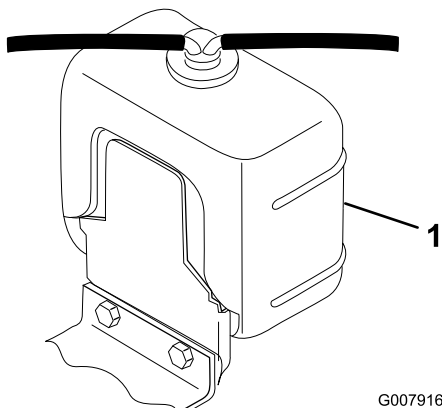

Figure 31

1. Expansion tank

3. Fill expansion tank to the Full mark and radiator to the top of the filler neck. **Do not overfill the expansion tank.**

Note: If air is trapped in system, remove vent plug (Figure 32), from top of radiator side tank, to allow trapped air to escape. Reinstall vent plug using Teflon thread sealant.

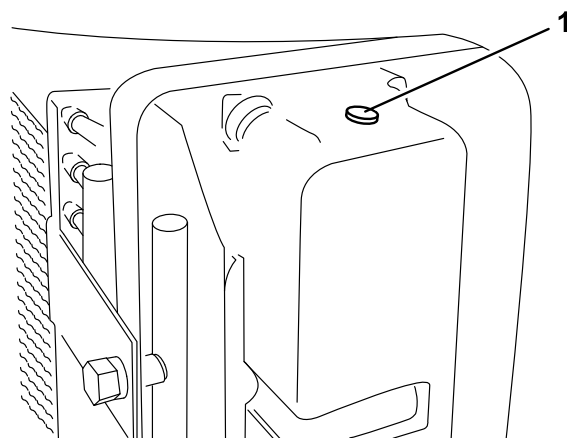

Figure 32

1. Vent plug

4. Install radiator cap and expansion tank cap.
5. Close hood and secure latch.

Filling the Fuel Tank

⚠ DANGER

Under certain conditions, diesel fuel and fuel vapors are highly flammable and explosive. A fire or explosion from fuel can burn you and others and can cause property damage.

- Use a funnel and fill the fuel tank outdoors, in an open area, when the engine is off and is cold. Wipe up any fuel that spills.
- Do not fill the fuel tank completely full. Add fuel to the fuel tank until the level is 1 in. (25 mm) below the bottom of the filler neck. This empty space in the tank allows the fuel to expand.
- Never smoke when handling fuel, and stay away from an open flame or where fuel fumes may be ignited by a spark.
- Store fuel in a clean, safety-approved container and keep the cap in place.

Use only clean, fresh diesel fuel or biodiesel fuels with low (<500 ppm) or ultra low (<15 ppm) sulfur content. The minimum cetane rating should be 40. Purchase fuel in quantities that can be used within 180 days to ensure fuel freshness.

Fuel tank capacity: 15 US gallons (57 l)

Use summer grade diesel fuel (No. 2-D) at temperatures above 20° F (-7° C) and winter grade (No. 1-D or No. 1-D/2-D blend) below that temperature. Use of winter grade fuel at lower temperatures provides lower

flash point and cold flow characteristics which will ease starting and reduce fuel filter plugging.

Use of summer grade fuel above 20° F (-7° C) will contribute toward longer fuel pump life and increased power compared to winter grade fuel.

Important: Do not use kerosene or gasoline instead of diesel fuel. Failure to observe this caution will damage the engine.

⚠ WARNING

Fuel is harmful or fatal if swallowed. Long-term exposure to vapors can cause serious injury and illness.

- Avoid prolonged breathing of vapors.
- Keep face away from nozzle and gas tank or conditioner opening.
- Keep fuel away from eyes and skin.

Biodiesel Ready

This machine can also use a biodiesel blended fuel of up to B20 (20% biodiesel, 80% petrodiesel). The petrodiesel portion should be low or ultra low sulfur. Observe the following precautions:

- The biodiesel portion of the fuel must meet specification ASTM D6751 or EN14214.
- The blended fuel composition should meet ASTM D975 or EN590.
- Painted surfaces may be damaged by biodiesel blends.
- Use B5 (biodiesel content of 5%) or lesser blends in cold weather.
- Monitor seals, hoses, gaskets in contact with fuel as they may be degraded over time.
- Fuel filter plugging may be expected for a time after converting to biodiesel blends.
- Contact your distributor if you wish for more information on biodiesel.

⚠ DANGER

In certain conditions, fuel is extremely flammable and highly explosive. A fire or explosion from fuel can burn you and others and can damage property.

- Fill the fuel tank outdoors, in an open area, when the engine is cold. Wipe up any fuel that spills.
- Never fill the fuel tank inside an enclosed trailer.
- Never smoke when handling fuel, and stay away from an open flame or where fuel fumes may be ignited by a spark.
- Store fuel in an approved container and keep it out of the reach of children. Never buy more than a 30-day supply of fuel.
- Do not operate without entire exhaust system in place and in proper working condition.

⚠ DANGER

In certain conditions during fueling, static electricity can be released causing a spark which can ignite the fuel vapors. A fire or explosion from fuel can burn you and others and can damage property.

- Always place fuel containers on the ground away from your vehicle before filling.
- Do not fill fuel containers inside a vehicle or on a truck or trailer bed because interior carpets or plastic truck bed liners may insulate the container and slow the loss of any static charge.
- When practical, remove equipment from the truck or trailer and refuel the equipment with its wheels on the ground.
- If this is not possible, then refuel such equipment on a truck or trailer from a portable container, rather than from a fuel dispenser nozzle.
- If a fuel dispenser nozzle must be used, keep the nozzle in contact with the rim of the fuel tank or container opening at all times until fueling is complete.

1. Park the machine on a level surface.
2. Using a clean rag, clean area around fuel tank cap.
3. Remove cap from the fuel tank (Figure 33).

Checking the Tire Pressure

Service Interval: Before each use or daily

The tires are over-inflated for shipping. Therefore, release some of the air to reduce the pressure. Correct air pressure in the front and rear tires is 15-20 psi.

Important: Maintain even pressure in all tires to ensure a good quality-of-cut and proper machine performance. Do not under inflate.

Checking the Reel to Bedknife Contact

Service Interval: Before each use or daily

Each day before operating, check reel to bedknife contact, regardless if quality of cut had previously been acceptable. There must be light contact across the full length of the reel and bedknife (refer to Adjusting Reel to Bedknife in Cutting Unit *Operator's Manual*).

Starting and Stopping

1. Sit on the seat, keep foot off traction pedal. Ensure parking brake is engaged, traction pedal is in Neutral, throttle is in Slow position and the Enable/Disable switch is in the Disable position.
2. Turn ignition switch to On/Preheat position. An automatic timer will control preheat for approximately 6 seconds. After preheat, turn key to Start position. Crank the engine for no longer than 15 seconds. Release key when engine starts. If additional preheat is required, turn key to Off position then to On/Preheat position. Repeat process as required.
3. Run engine at idle speed or partial throttle until engine warms up.
4. To stop, move all controls to Neutral and set parking brake. Return throttle to the idle position, turn key to OFF and remove it from switch.

Important: Allow engine to idle for 5 minutes before shutting it off after a full load operation. Failure to do so may lead to turbo-charger trouble.

Note: We recommend that anytime the machine is parked (short or long term) the cutting units should be lowered to the ground. This relieves pressure from the lift circuit and eliminates the risk of the cutting units accidentally lowering to the ground.

Bleeding the Fuel System

1. Park the machine on a level surface. Make sure fuel tank is at least half full.
2. Unlatch and raise hood.

▲ DANGER

Under certain conditions, diesel fuel and fuel vapors are highly flammable and explosive. A fire or explosion from fuel can burn you and others and can cause property damage.

- Use a funnel and fill the fuel tank outdoors, in an open area, when the engine is off and is cold. Wipe up any fuel that spills.
 - Do not fill the fuel tank completely full. Add fuel to the fuel tank until the level is 1 in. (25 mm) below the bottom of the filler neck. This empty space in the tank allows the fuel to expand.
 - Never smoke when handling fuel, and stay away from an open flame or where fuel fumes may be ignited by a spark.
 - Store fuel in a clean, safety-approved container and keep the cap in place.
3. Open vent plug on the fuel filter/water separator (Figure 35).

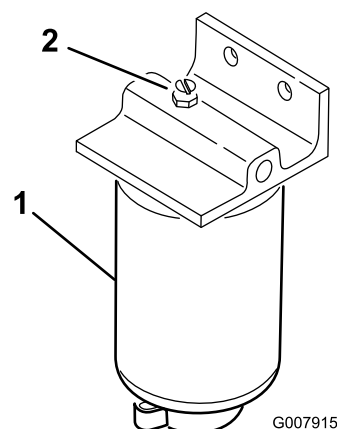

Figure 35

1. Fuel filter/water separator
2. Vent plug

4. Turn key in ignition switch to the On position. Electric fuel pump will begin operation, thereby forcing air out around vent plug. Leave key in On position until a solid stream of fuel flows out around plug. Tighten plug and turn key to OFF.
5. Open the air bleed screw on the fuel injection pump (Figure 36).

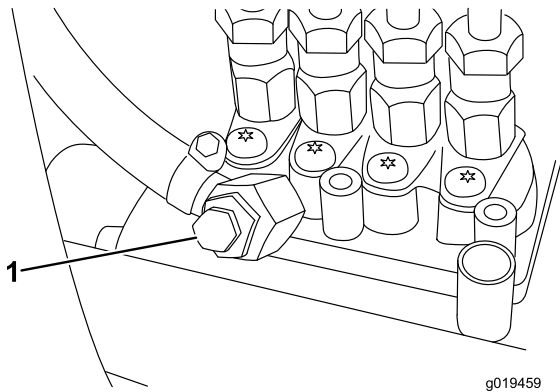

Figure 36

1. Fuel injection pump bleed screw

6. Turn key in ignition switch to the On position. Electric fuel pump will begin operation, thereby forcing air out around air bleed screw. Leave key in On position until a solid stream of fuel flows out around screw. Tighten screw and turn key to Off.

Note: Normally, engine should start after above bleeding procedures are followed. However, if engine does not start, air may be trapped between injection pump and injectors; refer to Bleeding Air From Injectors in the Maintenance Section.

Pushing or Towing the Machine

In an emergency, the machine can be moved by actuating the bypass valve in the variable displacement hydraulic pump and pushing or towing the machine.

Important: Do not push or tow the machine faster than 2-3 mph (3-4.8 km/h) because internal transmission damage may occur. The bypass valve must be open whenever the machine is pushed or towed.

1. The bypass valve is located on top of variable displacement pump (Figure 37). Rotate the valve 90°, in either direction, to open and allow oil to bypass internally. Because fluid is bypassed, the machine can be moved slowly without damaging the transmission.

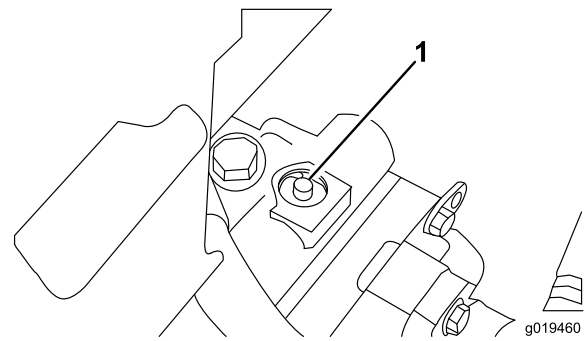

Figure 37

1. Bypass valve

2. Close the bypass valve before starting the engine. However, do not exceed 5-8 ft.-lb. (7-11 N·m) torque to close the valve.

Important: Running the engine with the bypass valve open will cause the transmission to overheat.

Checking the Interlock Switches

⚠ CAUTION

If safety interlock switches are disconnected or damaged the machine could operate unexpectedly causing personal injury.

- Do not tamper with the interlock switches.
- Check the operation of the interlock switches daily and replace any damaged switches before operating the machine.

The purpose of the interlock switches are to prevent the engine from cranking or starting unless the traction pedal is in Neutral, the Enable/Disable switch is in Disable and the Lower Mow/Raise control is in the neutral position. In addition, the engine will stop when the traction pedal is depressed with either the operator off the seat or the parking brake engaged.

To verify interlock switch function:

Service Interval: Before each use or daily

1. Park machine on a level surface, lower the cutting units, stop the engine and engage the parking brake.
2. Open control panel cover. Locate wire harness and loopback connector. Carefully unplug loopback connector from harness connector (Figure 38).

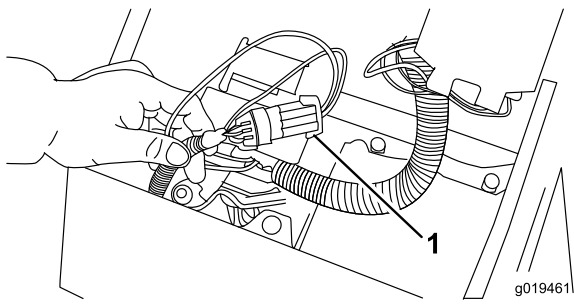

Figure 38

1. Loop-back connector

3. Connect the Diagnostic ACE display connector to the harness connector (Figure 39). Make sure correct overlay decal is positioned on Diagnostic ACE display.

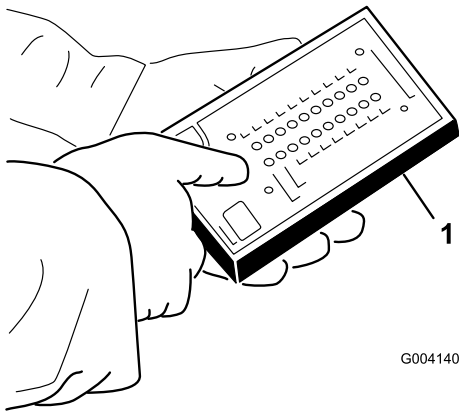

Figure 39

1. Diagnostic ACE

4. Turn the key switch to the On position, but do not start machine.

Note: The red text on the overlay decal refers to input switches and the green text refers to outputs.

5. The “inputs displayed” LED, on lower right column of the Diagnostic ACE, should be illuminated. If “outputs displayed” LED is illuminated, press and release the toggle button, on Diagnostic ACE, to change LED to “inputs displayed”. Do not hold button down.
6. The Diagnostic ACE will illuminate the LED associated with each of the inputs when that input switch is closed.

Individually, change each of the switches from open to closed (i.e., sit on seat, engage traction pedal, etc.), and note that the appropriate LED on Diagnostic ACE will blink on and off when

corresponding switch is closed. Repeat on each switch that is possible to be changed by hand.

7. If switch is closed and appropriate LED does not turn on, check all wiring and connections to switch and/or check switches with an ohm meter. Replace any damaged switches and repair any damaged wiring.

The Diagnostic ACE also has the ability to detect which output solenoids or relays are turned on. This is a quick way to determine if a machine malfunction is electrical or hydraulic.

To verify output function:

1. Park machine on a level surface, lower the cutting units, stop the engine and engage the parking brake.
2. Open control panel cover. Locate wire harness and connectors near controller. Carefully unplug loopback connector from harness connector.
3. Connect the Diagnostic ACE connector to the harness connector. Make sure correct overlay decal is positioned on Diagnostic ACE.
4. Turn the key switch to the On position, but do not start machine.

Note: The red text on the overlay decal refers to input switches and the green text refers to outputs.

5. The “outputs displayed” LED, on lower right column of Diagnostic ACE, should be illuminated. If “inputs displayed”; LED is illuminated, press the toggle button, on Diagnostic ACE, to change LED to “outputs displayed.”

Note: It may be necessary to toggle between “inputs displayed” and “outputs displayed” several times to do the following step. To toggle back and forth, press toggle button once. This may be done as often as required. Do not hold the button.

6. Sit on the seat and attempt to operate the desired function of the machine. The appropriate output LED's should illuminate to indicate that the ECU is turning on that function. (Refer to Hydraulic Solenoid Valve Functions to be certain of the specified output LEDs.)

Note: If any output LED is blinking, this indicates an electrical problem with that OUTPUT. Repair/replace defective electrical parts immediately. To reset a blinking LED, turn the key switch “Off”, then back “On” and clear the controllers fault memory (Refer to Clearing the Fault Memory in Fault Memory and Retrieval).

If no output LEDs are blinking, but the correct output LED's do not illuminate, verify that the

required input switches are in the necessary positions to allow that function to occur. Verify correct switch function.

If the output LEDs are on as specified, but the machine does not function properly, this indicates a non-electrical problem. Repair as necessary.

Note: Due to electrical system constraints, the output LED's for “Start”, “Preheat” and “ETR/ALT” may not blink even though an electrical problem may exist for those functions. If the machine problem appears to be with one of these functions, be certain to check the electrical circuit with a volt/ohm meter to verify that no electrical problem exists to these functions.

If each input switch is in the correct position and functioning correctly, but the output LEDs are not correctly illuminated, this indicates an ECU problem. If this occurs, contact your Toro Distributor for assistance.

Fault Memory and Retrieval

If the Controller senses a **fault** on one of the **output solenoids**, it will flash the machines diagnostic Lamp (Reel Diagnostic Lamp on console or Green Diagnostic Lamp under console) and store the fault into the Controllers (ECU) memory. The fault can then be retrieved and viewed with the Diagnostic ACE hand held tool or a lap top/PC at anytime. The Controller will store one (1) fault at a time and will not store another different fault until the first fault is cleared.

Retrieving Fault Information

Retrieving Stored Faults (Do not sit in seat)

1. Rotate ignition key to Off position.
2. Connect the Hand held Diagnostic Tool to the desired Controller Loopback Connector (use the proper overlay).
3. Move the Joystick to the Raise position and hold.
4. Rotate ignition key to On position, and continue to hold the Joystick in Raise position until the top left Diagnostic Tool light comes on (approx. 2 seconds).
5. Release the Joystick to the center position.
6. Hand held Tool will now playback the fault retained in the Controller memory.

Important: The display will show eight (8) individual records with the fault displayed on the 8th record. Each record will be displayed for 10 seconds. Be sure to have the Diagnostic

Tool display on Outputs to see fault. The Problem circuit will be flashing. Records will repeat until key is turned off. Unit will not start in this mode.

Clearing the Fault Memory (Diagnostic Tool not required)

7. Rotate ignition key to Off position.
8. Turn Backlap Switch to the Front or Rear Backlap position.
9. Turn the Reel Control Switch to Enable position.
10. Move the Joystick to the Raise position and hold.
11. Turn the ignition key to On, and continue to hold the Joystick in the Raise position until the Reel Control Lamp starts to flash (approx. 2 seconds).
12. Release the Joystick and turn the Key Off. Memory is now cleared.
13. Turn the Backlap Switch to Off and Enable Switch to Disable position.

Important: The Diagnostic ACE display must not be left connected to the machine. It is not designed to withstand the environment of the machine's every day use. When done using Diagnostic ACE, disconnect it from the machine and reconnect loopback connector to harness connector. Machine will not operate without loopback connector installed on harness. Store Diagnostic ACE in dry, secure location in shop, not on machine.

Hydraulic Solenoid Valve Functions

Use the list below to identify and describe the different functions of the solenoids in the hydraulic manifold. Each solenoid must be energized to allow function to occur.

Solenoid	Function
MSV1	Front reel circuit
MSV2	Rear reel circuit
SV4	Lift front wing cutting units
SV3	Lift front center cutting unit
SV5	Lift rear cutting units
SV1	Pressurize raise/lower hydraulic circuit
SV2	Direction: ON=Raise, OFF= Lower
SV 6	Left rear wing cutting unit

Solenoid	Function
SV 7	Right rear wing cutting unit
SV8	Load Holding

Operating Tips

Familiarization

Before mowing grass, practice operating machine in an open area. Start and stop the engine. Operate in forward and reverse. Lower and raise cutting units and engage and disengage reels. When you feel familiar with the machine, practice operating up and down slopes at different speeds.

The brakes can be used to assist in turning the machine. However, use them carefully, especially on soft or wet grass conditions because the turf may be torn accidentally. Individual turning brakes may also be used to help maintain traction. For example, in some slope conditions, the uphill wheel slips and loses traction. If this situation occurs, depress uphill turn pedal gradually and intermittently until the uphill wheel stops slipping, thus, increasing traction on the downhill wheel.

Important: Before mowing grass, practice operating the machine in turns. Turf damage in turns may occur especially under soft or wet grass conditions if the turn is completed at a high speed or at a small turning radius. Maintain a speed below 3 mph during a turn and a turning radius greater than 8 feet to minimize turf damage from tires or cutting units. Mounting the cutting units with the steering pin in the front mounting hole will allow the cutting unit to steer itself as the traction unit turns providing optimum maneuverability and cutting performance in turns. During cross-cutting of fairways, a tear drop shape turn is recommended to increase cutting productivity and minimize turf damage.

▲ DANGER

When operating the machine, always use the seat belt and ROPS together. Do not use a seat belt without a ROPS.

Warning System

If a warning light comes on during operation, stop the machine immediately and correct the problem before continuing operation. Serious damage could occur if the machine is operated with a malfunction.

Important: The Red Diagnostic Light , on the steering tower, indicates when the glow plugs are

On. The machine should not be started until the glow plug cycle is complete.

Mowing

Start engine and move throttle to FAST so engine is running at maximum speed. Move the Enable/Disable switch to ENABLE and use the LOWER MOW/RAISE lever to control the cutting units (front cutting units are timed to lower before the rear cutting units). To move forward and cut grass, press traction pedal forward. Maintain a speed which does not result in the Reel Control Light being illuminated. Gradually increase or decrease traction speed to ensure proper clip is maintained.

Transport

Move the Enable/Disable switch to Joy Stick Disable (mid position), lock brake pedals together and raise the cutting units to the transport position. Be careful when driving between objects so you do not accidentally damage the machine or cutting units. Use extra care when operating machine on slopes. Drive slowly and avoid sharp turns on slopes to prevent roll overs. The cutting units should be lowered when going downhill for steering control.

Maintenance

Note: Determine the left and right sides of the machine from the normal operating position.

Recommended Maintenance Schedule(s)

Maintenance Service Interval	Maintenance Procedure
After the first 8 hours	<ul style="list-style-type: none"> • Check the torque of the wheel nuts or bolts (after the first 1–4 hours of operation and then after 10 hours of operation).
After the first 50 hours	<ul style="list-style-type: none"> • Change the engine oil and oil filter.
After the first 200 hours	<ul style="list-style-type: none"> • Change the planetary gear drive oil. • Change the rear axle lubricant.
Before each use or daily	<ul style="list-style-type: none"> • Check the engine oil level. • Check and clean the cooling system. • Check the hydraulic fluid level. • Check the tire pressure. • Check the reel to bedknife contact. • Check the interlock switches. • Drain the fuel filter/water separator. • Remove debris from the rear screen, oil cooler, and radiator (more frequently in dirty conditions). • Inspect the hydraulic lines and hoses for leaks, kinked lines, loose mounting supports, wear, loose fittings, weather deterioration, and chemical deterioration.
Every 50 hours	<ul style="list-style-type: none"> • Grease the bearings and bushings. • Check the condition of the battery.
Every 100 hours	<ul style="list-style-type: none"> • Inspect and tighten the cooling system hoses and connections. • Check the condition and tension of the alternator belt.
Every 150 hours	<ul style="list-style-type: none"> • Change the engine oil and oil filter.
Every 200 hours	<ul style="list-style-type: none"> • Check the torque of the wheel nuts or bolts.
Every 400 hours	<ul style="list-style-type: none"> • Service the air cleaner. (Service the air cleaner earlier if the air cleaner indicator shows red. Service it more frequently in extremely dirty or dusty conditions.) • Check the fuel lines and connections. • Replace the fuel filter canister. • Check the planetary gear drive oil (Also, check if external leakage is observed) • Check the rear axle lubricant level.
Every 800 hours	<ul style="list-style-type: none"> • Change the planetary gear drive oil. (Or yearly, whichever comes first) • Change the rear axle lubricant. • Check the rear wheel toe-in. • Change the hydraulic fluid.
Every 2 years	<ul style="list-style-type: none"> • Drain and clean the fuel tank. • Drain and flush the cooling system. • Replace all moving hoses. • Drain/flush the hydraulic tank.

Important: Refer to your engine *Operator's Manual* for additional maintenance procedures.

▲ CAUTION

If you leave the key in the ignition switch, someone could accidentally start the engine and seriously injure you or other bystanders.

Remove the key from the ignition and disconnect the wire from the spark plug before you do any maintenance. Set the wire aside so that it does not accidentally contact the spark plug.

Service Interval Chart

REELMASTERS 6500-D / 6700-D QUICK REFERENCE AID



CHECK/SERVICE (daily)

1. OIL LEVEL, ENGINE
2. OIL LEVEL, HYDRAULIC TANK
3. COOLANT LEVEL, RADIATOR
4. FUEL /WATER SEPARATOR
5. AIR FILTER SERVICE INDICATOR
6. RADIATOR SCREEN
7. BRAKE FUNCTION
8. TIRE PRESSURE (15-20 PSI)

CHECK/SERVICE SEE OPERATOR'S MANUAL

9. BATTERY
10. BELTS (FAN, ALT.)
11. PLANETARY GEAR DRIVE
12. REAR AXLE OIL FILL**
13. REAR AXLE OIL CHECK (2)**

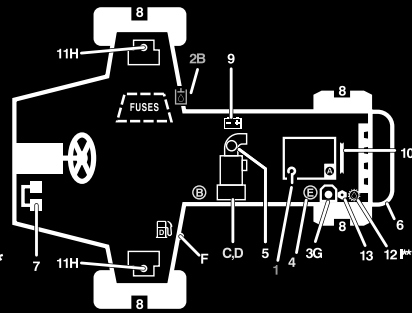

FLUID SPECIFICATIONS/CHANGE INTERVALS

SEE OPERATOR'S MANUAL FOR INITIAL CHANGES.	FLUID TYPE	CAPACITY	CHANGE INTERVAL		FILTER PART NO.
			FLUID	FILTER	
A. ENGINE OIL	SAE 15W-40	7.5 QTS.	150 HRS.	150 HRS.	108-3841
B. HYD. CIRCUIT OIL	MOBIL DTE15M	9 GALS.*	800 HRS.	SEE SERVICE INDICATOR	94-2621
C. PRIMARY AIR FILTER	---	---	---	SEE SERVICE INDICATOR	108-3812
D. SAFETY AIR FILTER	---	---	---	SEE OPERATOR'S MANUAL	108-3813
E. WATER SEPARATOR				400 HRS.	110-9049
F. FUEL TANK	NO. 2-DIESEL	15 GALS.	DRAIN AND FLUSH, 2 YRS.		
G. COOLANT	50/50 ETHELENE GLYCOL / WATER	2.5 GALS.	DRAIN AND FLUSH, 2 YRS.		
H. PLANETARY GEAR DRIVE	SAE85W-140	16 OZ.	800 HRS.	----	----
I. REAR AXLE OIL**	SAE85W-140	80 OZ.	800 HRS.	----	----

* INCLUDES FILTER, CHECK DIP STICK, DO NOT OVER FILL.

**4WD ONLY

115-2048

g023347

Figure 40

Daily Maintenance Checklist

Duplicate this page for routine use.

Maintenance Check Item	For the week of:						
	Mon.	Tues.	Wed.	Thurs.	Fri.	Sat.	Sun.
Check safety interlock operation.							
Check brake operation.							
Check engine oil and fuel level.							
Check cooling system fluid level.							
Drain the water/fuel separator.							
Check the air filter restriction indicator.							
Check the radiator and screen for debris.							
Check unusual engine noises. ¹							
Check unusual operating noises.							
Check the transmission oil level.							
Check the hydraulic system oil level.							
Check the hydraulic filter indicator. ²							
Check the hydraulic hoses for damage.							
Check for fluid leaks.							
Check the tire pressure.							
Check instrument operation.							
Check the reel-to-bedknife adjustment.							
Check the height-of-cut adjustment.							
Lubricate all grease fittings. ³							
Touch up damaged paint.							

1. Check the glow plug and injector nozzles if hard starting, excess smoke, or rough running is noted.
2. Check with the engine running and oil at operating temperature.
3. Immediately after every washing, regardless of the interval listed

Lubrication

Greasing the Bearings and Bushings

Service Interval: Every 50 hours

The machine has grease fittings that must be lubricated regularly with No. 2 General Purpose Lithium Base Grease. If machine is operated under normal conditions, lubricate all bearings and bushings after every 50 hours of operation or immediately after every washing.

The grease fitting locations and quantities are:

- Cutting unit carrier frame and pivot (2 ea.) (Figure 41).

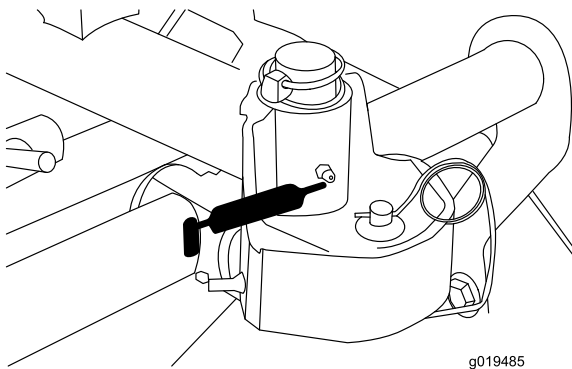

Figure 41

- Rear axle tie rod (2) (Figure 42).
- Steering cylinder ball joints (2) (Figure 42).
- King pin bushings (2) (Figure 42). **The top fitting on the king pin should only be lubricated annually (2 pumps).**

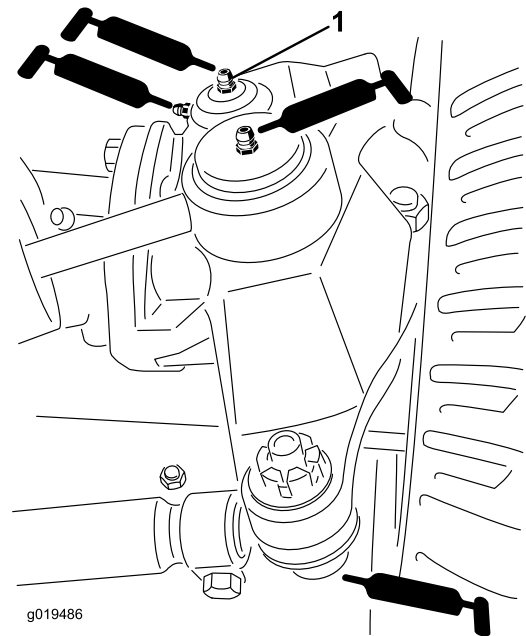

Figure 42

1. Top fitting on king pin

- Front lift cylinders (3) (Figure 43 and Figure 44).

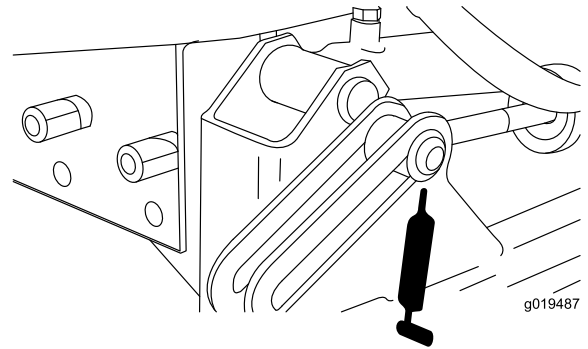

Figure 43

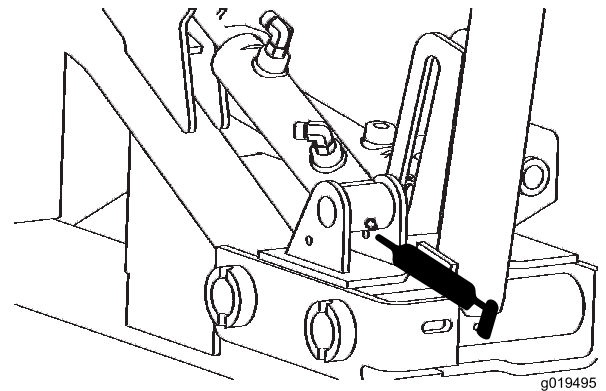

Figure 44

- Rear lift cylinder pivot (2) (Figure 45).

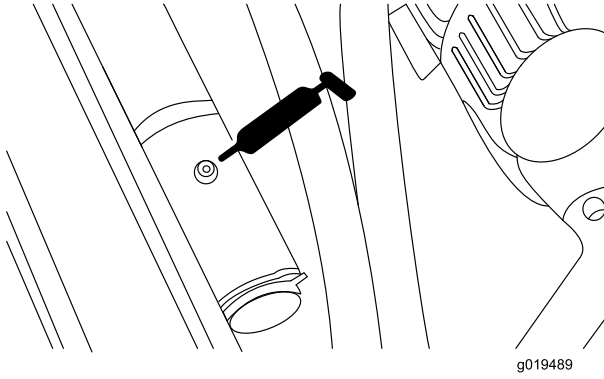

Figure 45

- Rear lift arm pivots (2) (Figure 48).

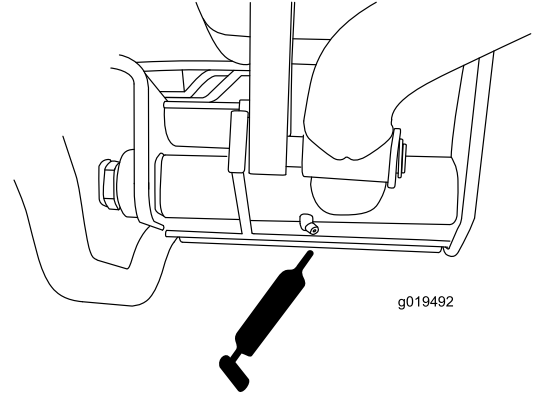

Figure 48

- Lift arm pivot (3) (Figure 46).

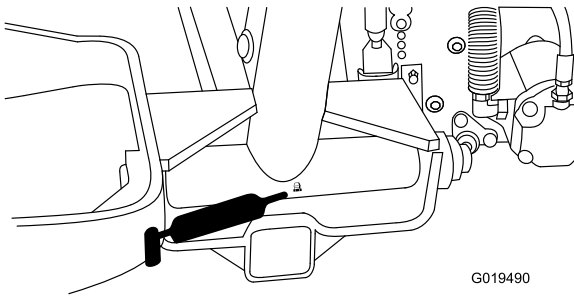

Figure 46

- Brake pedal shaft (1) (Figure 49).

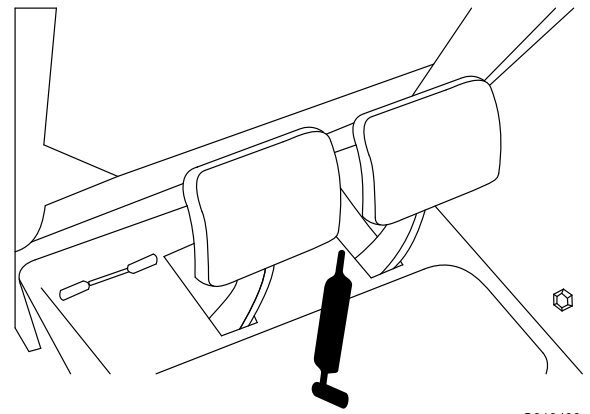

Figure 49

- Rear axle pivot (Figure 47).

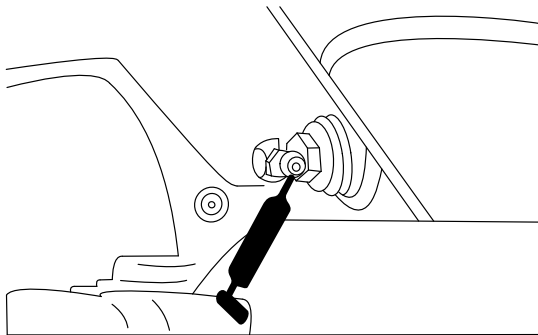

Figure 47

Engine Maintenance

Servicing the Air Cleaner

Service Interval: Every 400 hours

Check the air cleaner body for damage which could cause an air leak. Replace if damaged. Check the whole intake system for leaks, damage or loose hose clamps.

Service the air cleaner filter only when the service indicator (Figure 50) requires it. Changing the air filter before it is necessary only increases the chance of dirt entering the engine when the filter is removed.

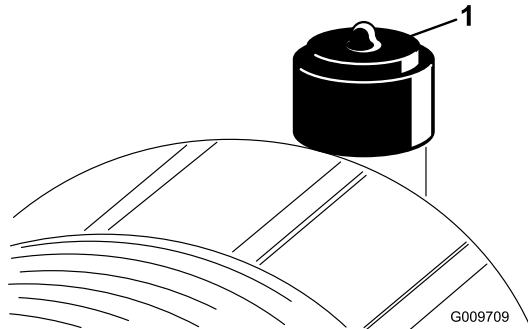

Figure 50

1. Air cleaner indicator

Important: Be sure the cover is seated correctly and seals with the air cleaner body.

1. Pull the latch outward and rotate the air cleaner cover counterclockwise (Figure 51).

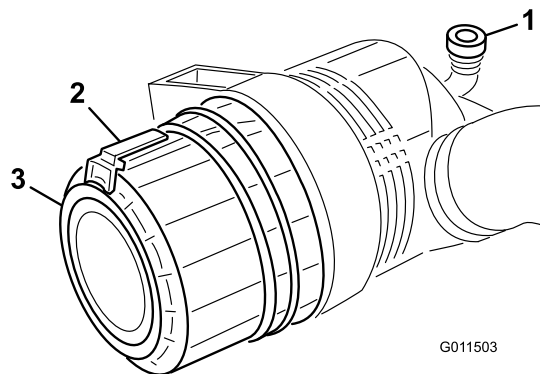

Figure 51

1. Air cleaner latch
2. Air cleaner cover

2. Remove the cover from the air cleaner body. Before removing the filter, use low pressure air (40 psi, clean and dry) to help remove large accumulations of debris packed between outside of primary filter and the canister. **Avoid using high pressure air which could force dirt through the filter into the intake tract.**

This cleaning process prevents debris from migrating into the intake when the primary filter is removed.

3. Remove and replace the primary filter (Figure 52).

Cleaning of the used element is not recommended due to the possibility of damage to the filter media. Inspect the new filter for shipping damage, checking the sealing end of the filter and the body. **Do not use a damaged element.** Insert the new filter by applying pressure to the outer rim of the element to seat it in the canister. **Do not apply pressure to the flexible center of the filter.**

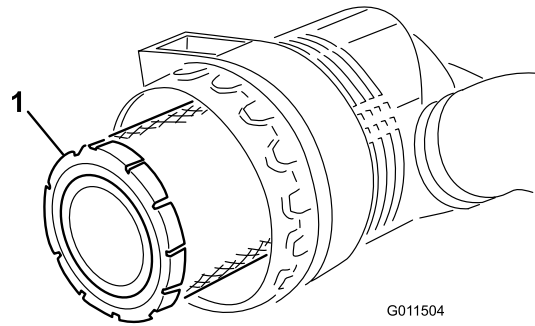

Figure 52

1. Air cleaner primary filter

Important: Never attempt to clean the safety filter (Figure 53). Replace the safety filter with a new one after every three primary filter services.

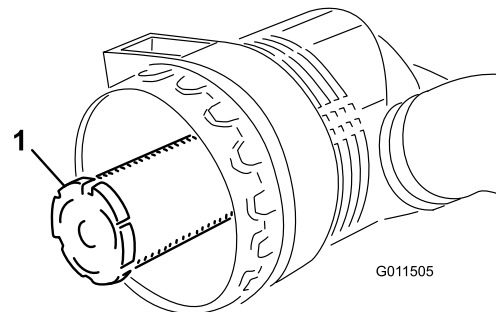

Figure 53

1. Air cleaner safety filter

4. Clean the dirt ejection port located in the removable cover. Remove the rubber outlet valve from the cover, clean the cavity and replace the outlet valve.
5. Install the cover orienting the rubber outlet valve in a downward position—between approximately 5:00 to 7:00 when viewed from the end.
6. Reset the indicator (Figure 50) if it shows red.

Servicing the Engine Oil and Filter

Service Interval: After the first 50 hours

Every 150 hours

Change oil and filter initially after the first 50 hours of operation, thereafter change oil and filter every 150 hours.

1. Remove drain plug (Figure 54) and let oil flow into drain pan. When oil stops, install drain plug.

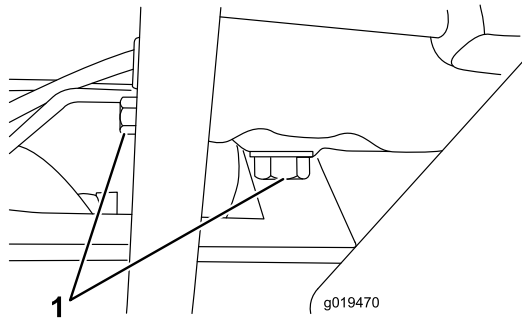

Figure 54

1. Drain plugs

2. Remove oil filter (Figure 55). Apply a light coat of clean oil to the new filter seal before screwing it on. Do not over-tighten.

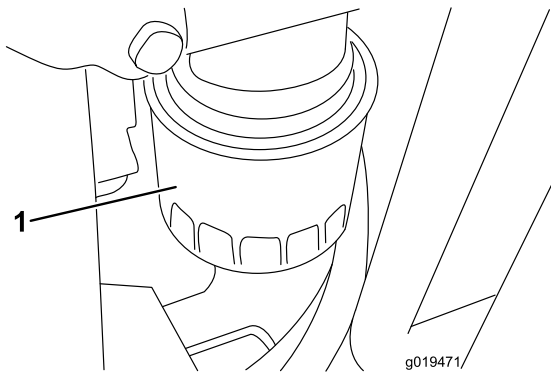

Figure 55

1. Oil filter

3. Add oil to the crankcase. Capacity is 7.5 qt. (7 L) with filter.

Adjusting Throttle

1. Position throttle lever forward so it stops against seat base slot.
2. Loosen the throttle cable connector on the lever arm at the injection pump (Figure 56).

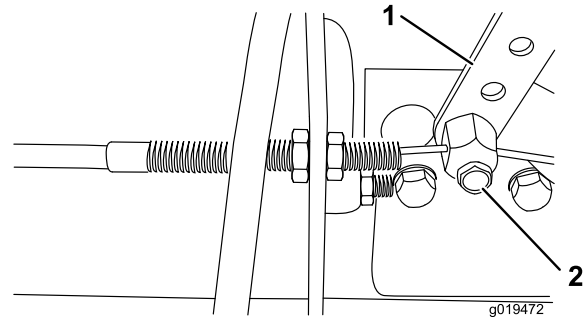

Figure 56

1. Injection pump lever arm
2. Connector

3. Hold the injection pump lever arm against the high idle stop and tighten the cable connector.

Note: When tightened, the cable connector must be free to swivel.

4. Torque the lock nut, used to set the friction device on the throttle lever, to 40-55 in-lb. The maximum force required to operate the throttle lever should be 20 lb.

Fuel System Maintenance

Fuel Tank

Service Interval: Every 2 years

Drain and clean fuel tank every 2 years. Also, drain and clean tank if fuel system becomes contaminated or if machine is to be stored for an extended period. Use clean fuel to flush out the tank.

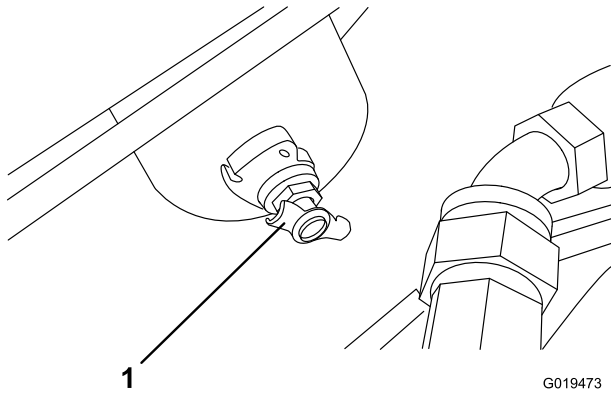

Figure 57

1. Fuel tank drain

⚠ DANGER

Under certain conditions, diesel fuel and fuel vapors are highly flammable and explosive. A fire or explosion from fuel can burn you and others and can cause property damage.

- Use a funnel and fill the fuel tank outdoors, in an open area, when the engine is off and is cold. Wipe up any fuel that spills.
- Do not fill the fuel tank completely full. Add fuel to the fuel tank until the level is 1/4 to 1/2 in. (6 to 13 mm) below the bottom of the filler neck. This empty space in the tank allows the fuel to expand.
- Never smoke when handling fuel, and stay away from an open flame or where fuel fumes may be ignited by a spark.
- Store fuel in a clean, safety-approved container and keep the cap in place.

Fuel Lines and Connections

Service Interval: Every 400 hours

Check lines and connections every 400 hours or yearly, whichever comes first. Inspect for deterioration, damage, or loose connections.

Fuel Filter/Water Separator

Service Interval: Before each use or daily
Every 400 hours

Drain water or other contaminants from fuel filter/water separator (Figure 58) daily.

1. Locate fuel filter, under hood, and place a clean container under it.
2. Loosen drain plug on bottom of filter canister. Tighten plug after draining.

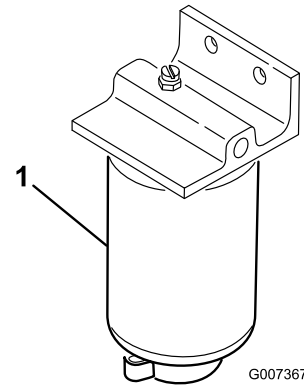

Figure 58

1. Water separator filter canister

Replace filter canister after every 400 hours of operation.

3. Clean area where filter canister mounts.
4. Remove filter canister and clean mounting surface.
5. Lubricate gasket on filter canister with clean oil.
6. Install filter canister by hand until gasket contacts mounting surface, then rotate an additional 1/2 turn.
7. Tighten the drain plug on the bottom of the filter canister.

Bleeding Air From Injectors

Note: This procedure should be used only if fuel system has been purged of air through normal priming procedures and engine will not start; refer to Bleeding the Fuel System in Operation Section.

1. Loosen the pipe connection to the No. 1 nozzle and holder assembly.

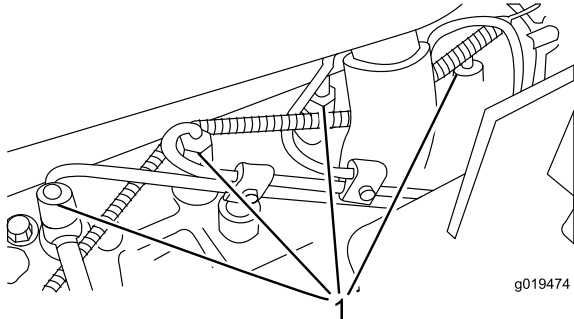

Figure 59

1. Fuel injectors (4)
-
2. Move throttle to Fast position.
 3. Turn key in key switch to Run position and watch fuel flow around connector. Turn key to Off position when solid flow is observed.
 4. Tighten pipe connector securely.
 5. Repeat steps 1 through 4 on remaining nozzles.
- Note:** Fan shroud may be easily unbolted from machine to simplify cleaning.
6. Install rear screen and secure latches.

Note: Do not use water to clean engine, as damage may occur.

Electrical System Maintenance

Battery Care

Service Interval: Every 50 hours

WARNING

CALIFORNIA Proposition 65 Warning

Battery posts, terminals, and related accessories contain lead and lead compounds, chemicals known to the State of California to cause cancer and reproductive harm.
Wash hands after handling.

Important: Before welding on a machine, disconnect both cables from the battery, disconnect both wire harness plugs from the electronic control unit and the terminal connector from the alternator to prevent damage to the electrical system.

⚠ WARNING

Battery terminals or metal tools could short against metal tractor components causing sparks. Sparks can cause the battery gasses to explode, resulting in personal injury.

- When removing or installing the battery, do not allow the battery terminals to touch any metal parts of the machine.
- Do not allow metal tools to short between the battery terminals and metal parts of the machine.

⚠ WARNING

Incorrect battery cable routing could damage the tractor and cables causing sparks. Sparks can cause the battery gasses to explode, resulting in personal injury.

- Always disconnect the negative (black) battery cable before disconnecting the positive (red) cable.
- Always connect the positive (red) battery cable before connecting the negative (black) cable.

Note: Check battery condition weekly or after every 50 hours of operation. Keep terminals and entire battery case clean because a dirty battery will discharge slowly. To clean the battery, wash the entire case with solution

of baking soda and water. Rinse with clear water. Coat the battery posts and cable connectors with Grafo 112X (skin-over) grease (Toro Part No. 505-47) or petroleum jelly to prevent corrosion.

⚠ DANGER

Battery electrolyte contains sulfuric acid which is a deadly poison and causes severe burns.

- Do not drink electrolyte and avoid contact with skin, eyes or clothing. Wear safety glasses to shield your eyes and rubber gloves to protect your hands.
- Fill the battery where clean water is always available for flushing the skin.

Fuses

There are 7 fuses in the machines electrical system. They are located below the operators control panel (Figure 60 and Figure 61).

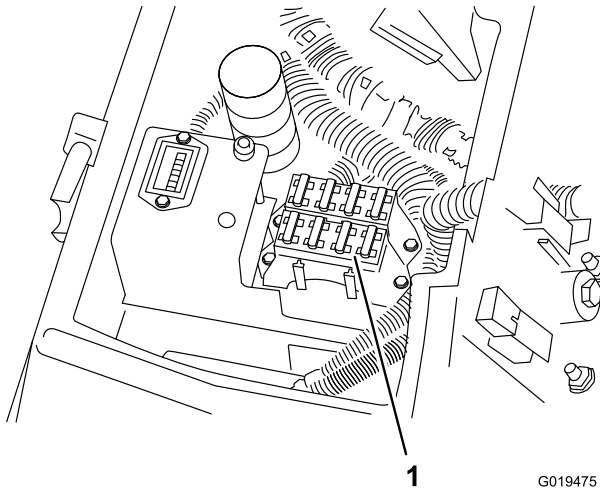
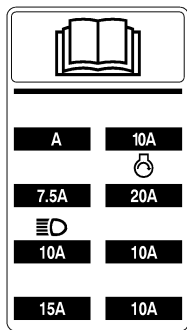

Figure 60

G019475

1. Fuses



G000775

Figure 61

Optional Lighting

Important: If optional lighting is be added to the traction unit, use the instructions, schematic (Figure 62), and part numbers listed below to prevent damage to the traction units electrical system.

Installation Instructions

1. Install a relay into the open connector under console.
2. Install light switch.

Note: Punch out in control panel provided for switch installation.

3. Crimp a ring or fork terminal onto each of the orange wires (J 24 & J 25) under console. Secure them to light switch terminals #2 & #3.
4. Splice power (+) wires from lights to red wire at J 23.
5. Secure ground wires from lights to the engine block ground.
6. Install a 10 amp. fuse to fuse block at location shown on fuse block decal. Do not exceed fuse rating.

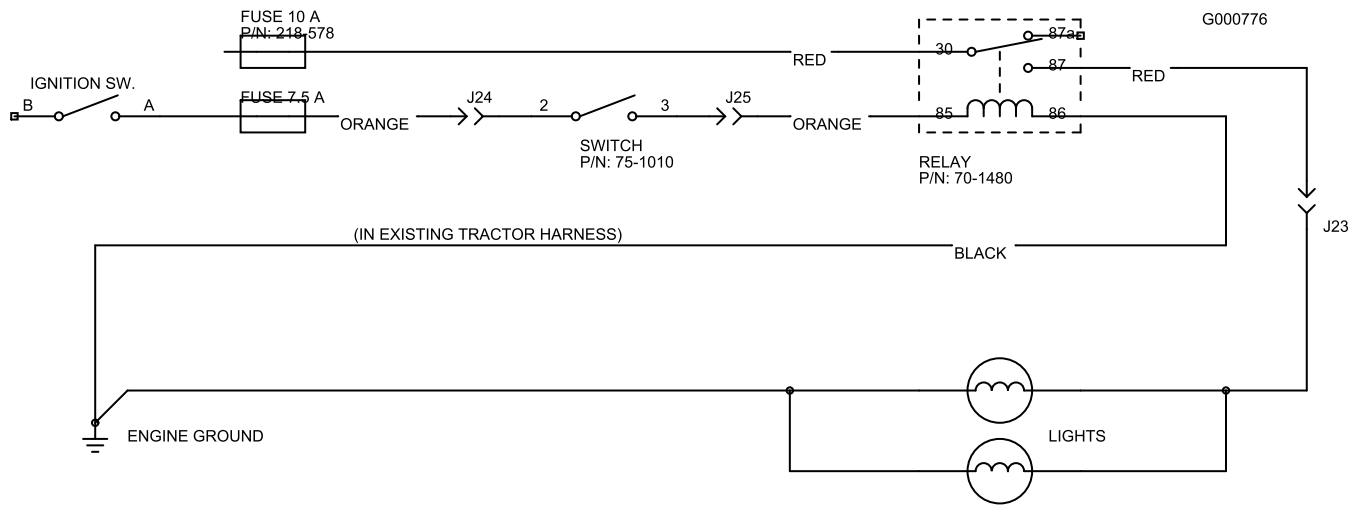

Figure 62

Switch	Relay
Toro Part No. 75-1010	Toro Part No. 70-1480
Honeywell Part No. 1TL1-2	Hella Part No. 87411 B

Drive System Maintenance

Checking the Torque of the Wheel Nuts or Bolts

Service Interval: After the first 8 hours
Every 200 hours

▲ WARNING

Failure to maintain proper torque of the wheel nuts could result in personal injury.

Torque the front wheel nuts and rear wheel bolts to 85-100 ft.-lb. after 1-4 hours of operation and again after 10 hours of operation. Torque every 200 hours thereafter.

Checking the Planetary Gear Drive Oil

Service Interval: Every 400 hours (Also, check if external leakage is observed)

Check the oil level every 400 hours of operation. Use high quality SAE 85W-140 wt. gear lube as a replacement.

1. With machine on level surface, position the wheel so one check plug (Figure 63) is at the 12 o'clock position and the other is at 3 o'clock position.

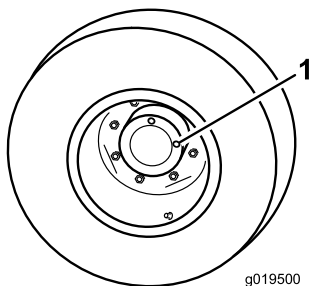

Figure 63

1. Check plug (2)
-
2. Remove the plug at the 3 o'clock position (Figure 63). Oil level should be at the bottom of the check plug hole.
 3. If the oil level is low, remove the plug at the 12 o'clock position and add oil until it begins to flow out of the hole at the 3 o'clock position.
 4. Re-install both plugs.
 5. Repeat steps 1 through 4 on the opposite planetary gear assembly.

Changing the Planetary Gear Drive Oil

Service Interval: After the first 200 hours

Every 800 hours (Or yearly, whichever comes first)

Change the oil initially after 200 hours operation. Thereafter, change the oil every 800 hours. Use high quality SAE 85W-140 wt. gear lube as replacement.

1. With machine on level surface, position a wheel so one of the check/drain plugs is at the lowest (6 o'clock) position (Figure 64).

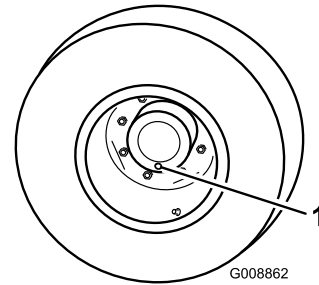

Figure 64

1. Check/drain plug
-
2. Place a drain pan under the planetary hub, remove plug and allow oil to drain.
 3. Place a drain pan under the brake housing, remove the drain plug and allow the oil to drain (Figure 65).

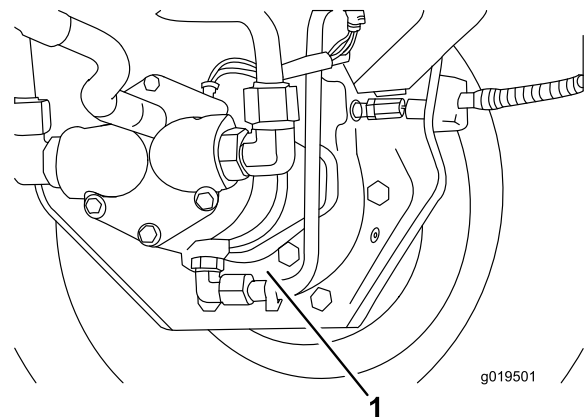

Figure 65

1. Brake housing drain plug
-
4. When all of the oil has drained from both locations, re-install the plug in the brake housing.
 5. Rotate the wheel until the open plug hole in the planetary is at the twelve o'clock position.
 6. Through the open hole, slowly fill the planetary with 22 ounces. (0.6 liter) of high quality SAE 85W-140 wt. gear lube.

Important: If the planetary fills before the 22 ounces (0.6 liter) of oil is added, wait one hour or install the plug and move the machine approximately ten feet to distribute the oil through the brake system. Then, remove the plug and add the remaining oil.

7. Re-install the plug.
8. Repeat the procedure on the opposite planetary/brake assembly.

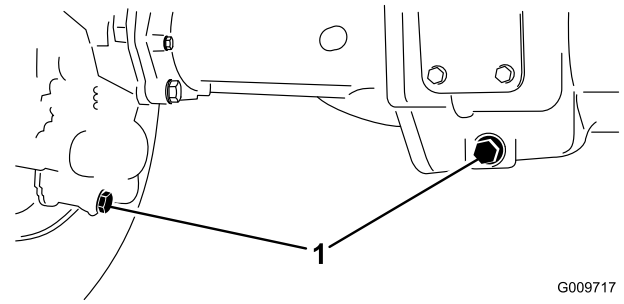

Figure 67

G009717

1. Drain plug location

Checking the Rear Axle Lubricant

Service Interval: Every 400 hours

The rear axle is shipped from the factory filled with SAE 85W-140 wt. gear lube. Check level before engine is first started and every 400 hours thereafter. Capacity is 80 oz. Visually inspect for leaks daily.

1. Position the machine on a level surface.
2. Remove a check plug (Figure 66) from one end of axle and make sure lubricant is up to bottom of hole. If level is low, remove the fill plug (Figure 66) and add enough lubricant to bring the level up to the bottom of the check plug holes.

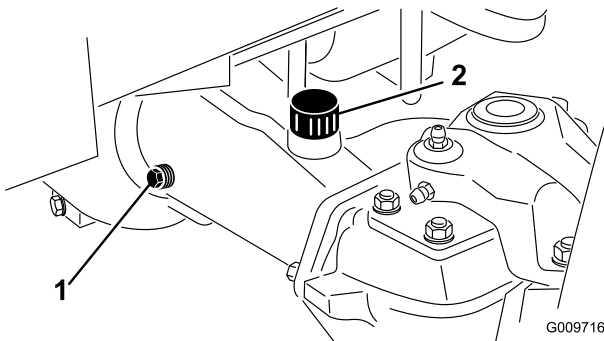

Figure 66

G009716

1. Check plug
2. Fill plug

Changing the Rear Axle Lubricant

Service Interval: After the first 200 hours

Every 800 hours

Change the oil initially after the first 200 hours of operation and every 800 hours of operation thereafter.

1. Position the machine on a level surface.
2. Clean the area around the 3 drain plugs, 1 on each end and 1 in the center (Figure 67).

Rear Wheel Toe-In

Service Interval: Every 800 hours

After every 800 operating hours or annually, check the rear wheel toe-in.

1. Measure the center-to-center distance (at axle height) at the front and rear of the steering tires. The front measurement must be 1/8 in. (3 mm) less than the rear measurement.
2. To adjust, remove the cotter pin and nut from either tie rod ball joint. Remove tie rod ball joint from axle case support (Figure 68).
3. Loosen the clamps at both ends of the tie rods (Figure 68).

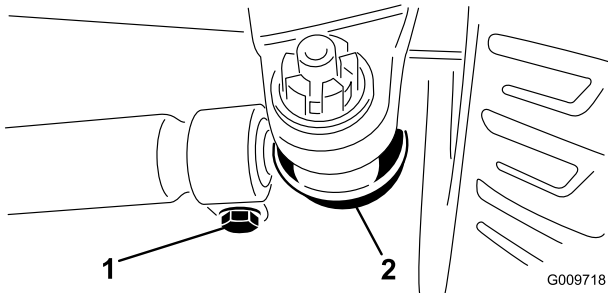

Figure 68

1. Tie rod clamp
2. Tie rod ball joint

4. Rotate the detached ball joint inward or outward one (1) complete revolution. Tighten clamp at loose end of tie rod.
5. Rotate the entire tie rod assembly the same direction (inward or outward) one (1) complete revolution. Tighten clamp at connected end of tie rod.
6. Install the ball joint in the axle case support and tighten the nut finger tight. Measure toe-in.
7. Repeat procedure if necessary.
8. Tighten the nut and install a new cotter pin when the adjustment is correct.

Adjusting the Traction Drive for Neutral

The machine must not creep when traction pedal is released. If it does creep, an adjustment is required.

1. Park machine on a level surface, shut engine off and lower cutting units to the floor. Depress only the right brake pedal and engage the parking brake.
2. Jack up left side of machine until front tire is off the shop floor. Support machine with jack stands to prevent it from falling accidentally.

Note: On 4 wheel drive models, left rear tire must also be off the shop floor.

3. Start engine and allow run at low idle.
4. Adjust jam nuts on pump rod end to move pump control tube forward to eliminate forward creep or rearward to eliminate rearward creep (Figure 69).

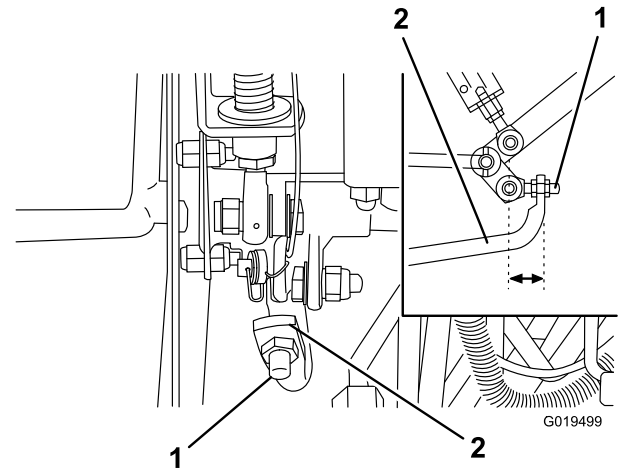

Figure 69

1. Pump rod
2. Pump control tube

5. After wheel rotation ceases, tighten jam nuts to secure adjustment.
6. Stop the engine and release the right brake. Remove jack stands and lower the machine to the shop floor. Test drive the machine to make sure it does not creep.

Cooling System Maintenance

Removing Debris

Service Interval: Before each use or daily

Remove debris from rear screen, oil cooler and radiator daily, clean more frequently in dirty conditions.

Important: Never spray water onto a hot engine as damage to engine may occur.

1. Turn engine off, release hood latch and raise hood. Clean engine area thoroughly of all debris. Close hood.
2. Unlatch and remove rear screen (Figure 70). Clean screen thoroughly.

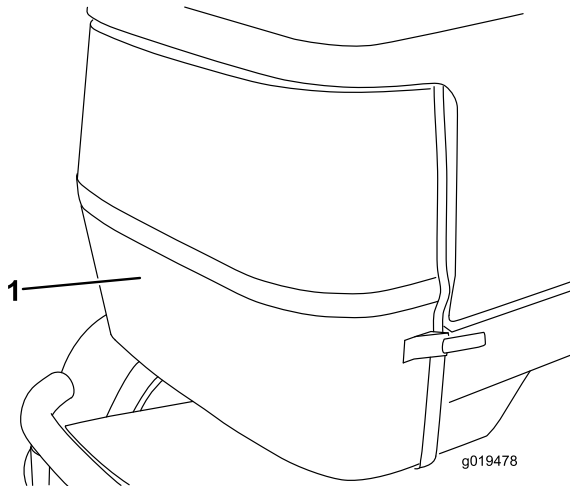

Figure 70

1. Rear screen

3. Unscrew knobs and pivot oil cooler rearward (Figure 71). Clean both sides of oil cooler and radiator area thoroughly with compressed air. Do not use water. Open hood and blow debris out toward back of machine. Pivot oil cooler back into position and tighten knobs.

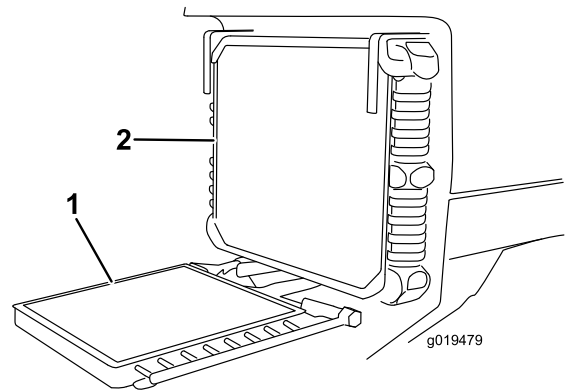

Figure 71

1. Oil cooler
2. Radiator

Maintaining the Cooling System

Service Interval: Every 100 hours

Every 2 years

Capacity of the system is 10 qts. (9.4 l). Always protect cooling system with a 50/50 solution of water and permanent ethylene glycol anti-freeze. Do not use water only in the cooling system.

1. After every 100 operating hours, inspect and tighten hose connections. Replace any deteriorated hoses.
2. After every 2 years, drain and flush the cooling system. Add anti-freeze; refer to Checking the Cooling System in the Operation Section.

Brake Maintenance

Adjusting the Service Brakes

Adjust the service brakes when there is more than 1 inch of free travel of the brake pedal, or when the brakes do not work effectively. Free travel is the distance the brake pedal moves before braking resistance is felt.

1. Disengage locking pin from brake pedals so both pedals work independently of each other.
2. To reduce free travel of brake pedals, tighten the brakes by loosening the front nut on the threaded end of the brake cable (Figure 72). Then tighten rear nut to move cable backward until brake pedals have 1/2 to 1 inch of free travel. Tighten front nuts after brakes are adjusted correctly.

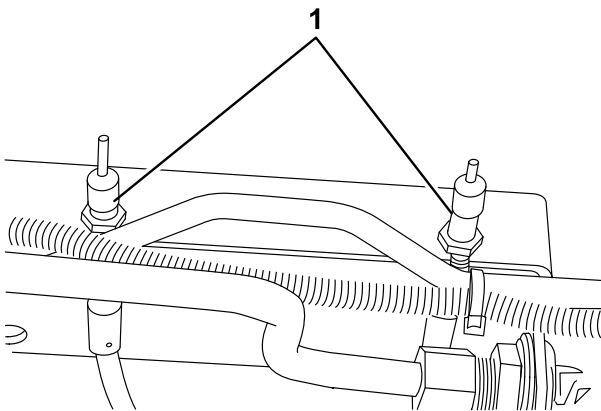

G019480

Figure 72

1. Brake cables

Belt Maintenance

Checking the Alternator Belt

Service Interval: Every 100 hours

Check condition and tension of alternator belt after every 100 hours of operation (Figure 73). Replace belt as required. Check the tension as follows:

1. Open hood.
2. Check tension by depressing belt midway between alternator and crankshaft pulleys with 22 lb. of force. Belt should deflect 7/16 in. If deflection is incorrect, proceed to step 3. If correct, continue operation.

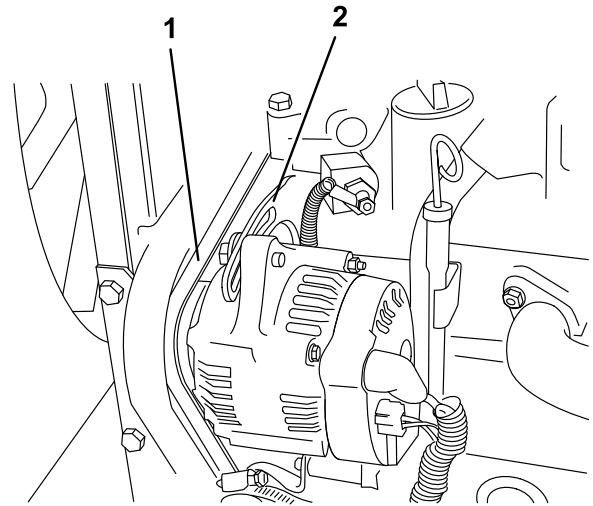

G019481

Figure 73

1. Alternator belt
2. Brace

3. Loosen bolt securing brace to engine and bolt securing alternator to brace.
4. Insert pry bar between alternator and engine and pry out on alternator.
5. When proper tension is achieved, tighten alternator and brace bolts to secure adjustment.
6. Tighten lock nut to secure adjustment.

Hydraulic System Maintenance

Changing the Hydraulic Fluid

Service Interval: Every 800 hours

Change hydraulic fluid after every 800 operating hours, in normal conditions. If fluid becomes contaminated, contact your local Toro distributor because the system must be flushed. Contaminated fluid looks milky or black when compared to clean oil.

1. Turn engine off and raise hood.
2. Remove drain plug from bottom of reservoir (Figure 74) and let hydraulic fluid flow into drain pan. Install and tighten plug when hydraulic fluid stops draining.

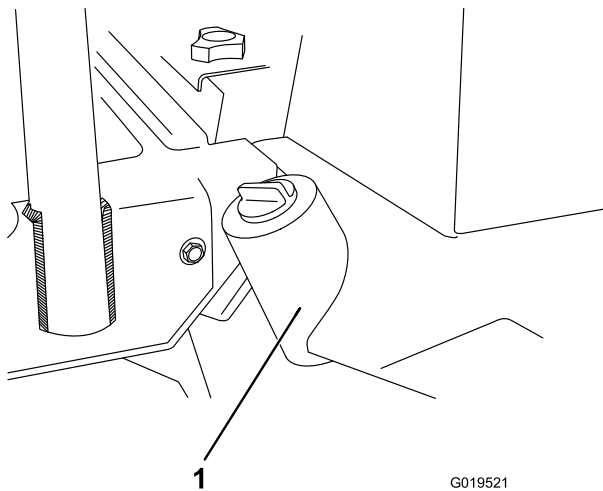

Figure 74

1. Hydraulic reservoir

3. Fill reservoir with approximately 8.5 gallons of hydraulic fluid; refer to Checking the Hydraulic Fluid.

Important: Use only hydraulic fluids specified. Other fluids could cause system damage.

4. Install reservoir cap. Start engine and use all hydraulic controls to distribute hydraulic fluid throughout the system. Also check for leaks. Then stop the engine.
5. Check level of fluid and add enough to raise level to Full mark on dipstick. Do not overfill.

Replacing the Hydraulic Filter

The hydraulic system filter head is equipped with a service interval indicator. With the engine running, view the indicator, it should be in the GREEN zone. When the indicator is in the RED zone, the filter element should be changed.

Use the Toro replacement filter (Part No. 94-2621).

Important: Use of any other filter may void the warranty on some components.

1. Position machine on a level surface, lower the cutting units, stop the engine, engage the parking brakes and remove key from ignition switch.
2. Clean area around filter mounting area. Place drain pan under filter and remove filter (Figure 75).

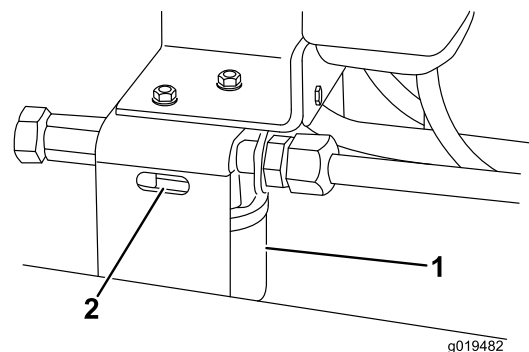

Figure 75

1. Hydraulic filter
2. Service interval indicator

3. Lubricate new filter gasket and fill the filter with hydraulic fluid.
4. Ensure that the filter mounting area is clean. Screw filter on until gasket contacts mounting plate. Then tighten filter 1/2 turn.
5. Start engine and let run for about two minutes to purge air from the system. Stop the engine and check for leaks.

Checking the Hydraulic Lines and Hoses

Service Interval: Before each use or daily

Inspect hydraulic lines and hoses daily for leaks, kinked lines, loose mounting supports, wear, loose fittings, weather deterioration and chemical deterioration. Make all necessary repairs before operating.

⚠ WARNING

Hydraulic fluid escaping under pressure can penetrate skin and cause injury.

- Make sure all hydraulic fluid hoses and lines are in good condition and all hydraulic connections and fittings are tight before applying pressure to the hydraulic system.
- Keep your body and hands away from pin hole leaks or nozzles that eject high pressure hydraulic fluid.
- Use cardboard or paper to find hydraulic leaks.
- Safely relieve all pressure in the hydraulic system before performing any work on the hydraulic system.
- Get immediate medical help if fluid is injected into skin.

Hydraulic System Test Ports

The test ports are used to test pressure in the hydraulic circuits. Contact your local Toro distributor for assistance.

1. Test Port A (Figure 76 and Figure 77) is used to assist in trouble shooting the hydraulic circuit for the lift cylinders.

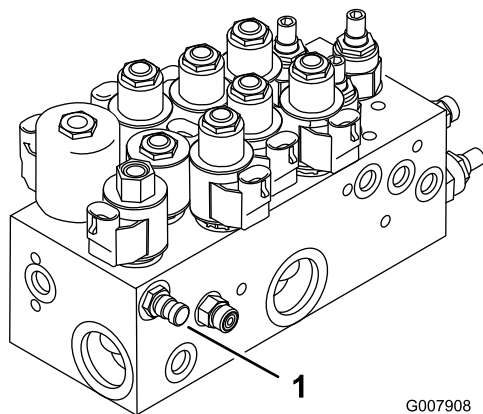

Figure 76

Model 03808 and 03813

1. Test port A (Lift cylinders)

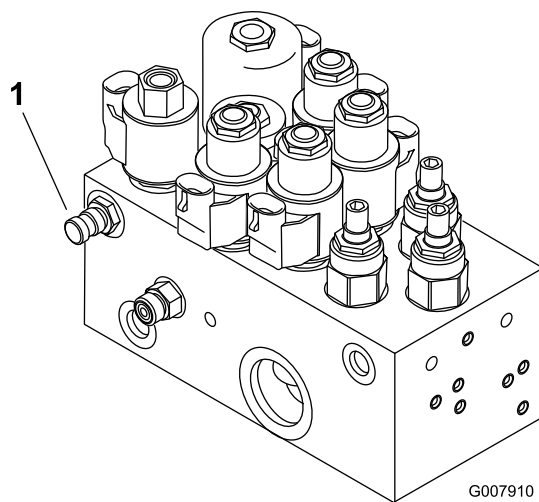

Figure 77

Models 03806, 03807 and 03812

1. Test port A (Lift cylinders)
2. Test Port B (Figure 78) is used to assist in trouble shooting the hydraulic circuit for the front cutting units.
3. Test Port C (Figure 78) is used to assist in trouble shooting the hydraulic circuit for the rear cutting units.

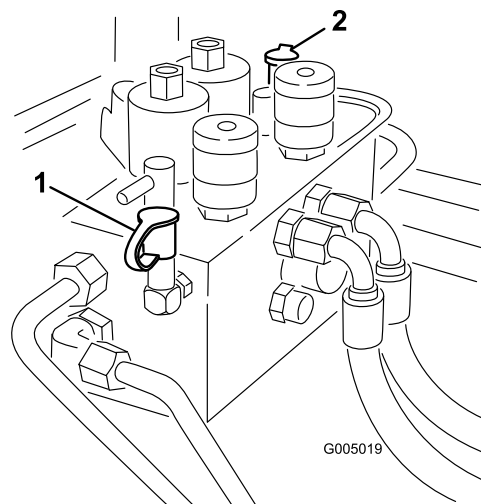

Figure 78

1. Test port B (Front cutting units)
2. Test port C (Rear cutting units)

4. Test Port D is located on the bottom of the hydrostatic transmission (Figure 79) and is used to measure the charge pressure of the transmission.
5. Test Port E is used to measure traction forward pressure (Figure 79).

6. Test Port F is used to measure traction reverse pressure (Figure 79).
7. Test Port G is used to measure steering circuit pressure (Figure 79).

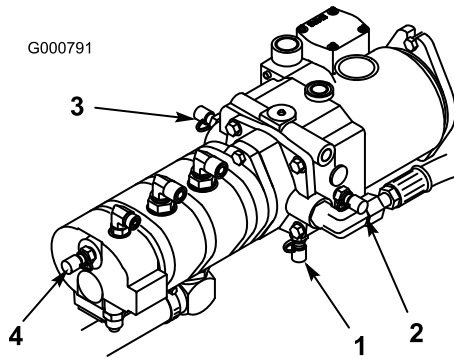

Figure 79

- | | |
|--|--|
| 1. Test port D (Charge pressure) | 3. Test port F (Traction reverse pressure) |
| 2. Test port E (Traction forward pressure) | 4. Test port G (Steering circuit pressure) |

Cutting Unit Maintenance

Cutting Unit Kickstand Models 03863 and 03864

Whenever the cutting unit has to be tipped to expose the bedknife/reel, prop up the rear of the cutting unit with the kickstand (supplied with the traction unit) to make sure the nuts on the back end of the bedbar adjusting screws are not resting on the work surface (Figure 80).

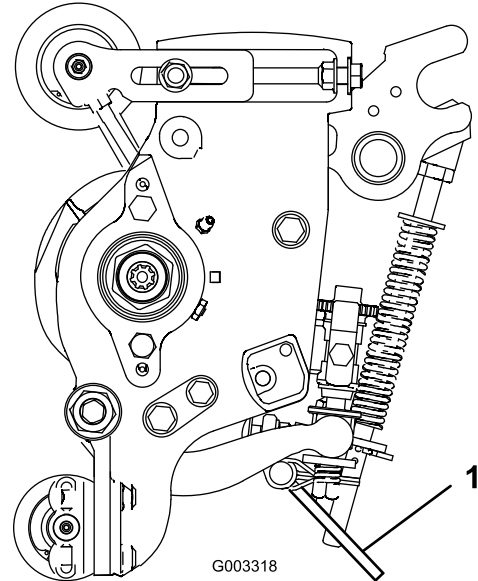

Figure 80

1. Cutting unit kickstand

Backlapping

⚠ DANGER

The reels may stall while backlapping and could restart suddenly. Contact with the reels during backlapping will cause personal injury.

- Never place hands or feet in the reel area while the engine is running.
- Never attempt to turn the reels by hand or foot or touch the reels while backlapping.
- Never change engine speed while backlapping. Only backlap at idle speed.
- Stop the engine and move the desired reel speed selector knob(s) one position closer to "13."

Note: When backlapping, the front units all operate together, and the rear units operate together.

1. Position the machine on a level surface, lower the cutting units, stop the engine, engage the parking

brake, and move the Enable/Disable switch to disable position.

2. Unlock and raise the seat to expose controls.
3. Locate the reel speed selector knobs and backlap knobs (Figure 81). Rotate the desired backlap knob(s) to the backlap position and the desired reel speed selector knob(s) to position 1.

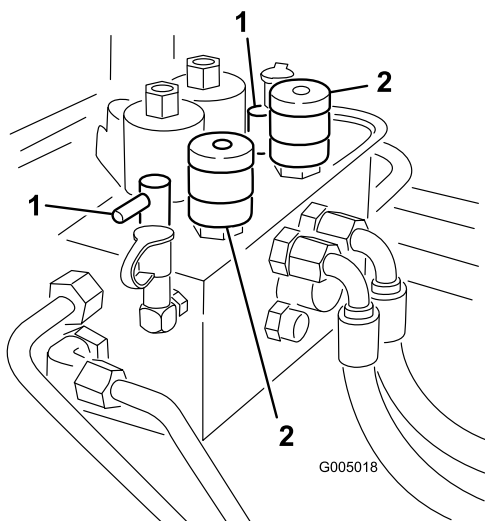

Figure 81

1. Backlap knobs
2. Reel speed selector knobs

Note: Backlapping speed may be increased by moving the reel speed selector knob toward 13. Each position will increase speed approximately 100 rpm. After changing selector, wait 30 seconds for the system to stabilize at the new speed.

4. Make initial reel to bedknife adjustments appropriate for backlapping on all cutting units which are to be backlapped.
5. Start engine and run at idle speed.

⚠ CAUTION

Contact with the reels or other moving parts can result in personal injury.

- Keep finger, hands, and clothing away from the reels and other moving parts.
- Never use a short handles brush to apply lapping compound.

6. Select either front, rear, or both backlap knobs to determine which reels will be backlapped.
7. Move Enable/Disable switch to Enable position. Move Lower Mow/Lift control forward to start backlapping operation on designated reels.
8. Apply lapping compound with a long handle brush (Toro Part No. 29-9100). Never use a short handled brush.

9. If reels stall or become erratic while backlapping, stop backlapping by moving the Lower Mow/Lift control lever rearward. Once the reels have stopped, move the desired reel speed selector knob(s) one position closer to 13. Resume backlapping by moving the Lower Mow/Lift control lever forward.
10. To make an adjustment to the cutting units while backlapping, turn reels Off by moving the Lower Mow/Raise lever rearward; move the Enable/Disable switch to Disable and turn the engine Off. After adjustments have been completed, repeat steps 5 through 9.
11. When the cutting unit is adequately sharpened, a burr will form on the front edge of the knife. Using a file, carefully remove the burr without dulling the cutting edge.
12. Repeat procedure for all cutting units to be backlapped.

When backlap operation has been completed, return the backlap knobs to the forward flow position, lower seat and wash all lapping compound off cutting units. Adjust cutting unit reel to bedknife as needed.

Note: If the backlap knobs are not returned to the forward flow position after backlapping, the cutting units will not raise or function properly.

Adjusting the Cutting Unit Lowering Rate

Tractors are setup at the factory appropriately for most fairway mowing applications.

The following adjustments are available for fine-tuning of the machine to the application:

The cutting unit lift circuits are equipped with adjustable valves to ensure the cutting units lower at the desired rate. Adjust as follows:

Run traction unit until operating temperature is reached.

1. Locate the valves, on the lift manifold, for adjusting the desired cutting unit(s) (See chart and Figure 82 and Figure 83).

Valve	Cutting Unit Affected
FC1	#1 (Front Center)
FC4	#4 & #5 (Front Wings)
FC5	#2 & #3 (Rear)
FC6	#6 (Rear Left)
FC7	#7 (Rear Right)

Lifted Height of Outer Front Cutting Units (Enable Position)

The turnaround height of the front outer cutting units (#4 & #5) and rear (#6 & #7) cutting units may be increased to provide additional ground clearance on contoured fairways.

Note: The RM CONFIG time delay should not be changed from the original setting of 0 when using this method to adjust turn around height.

To increase/adjust the turn around height of the cutting units proceed as follows:

- Position machine on a level surface, lower the cutting units and stop the engine.
- Loosen the carriage bolt nut securing the lift arm switch bracket to the #4, 6 or 7 lift arms (Figure 84).

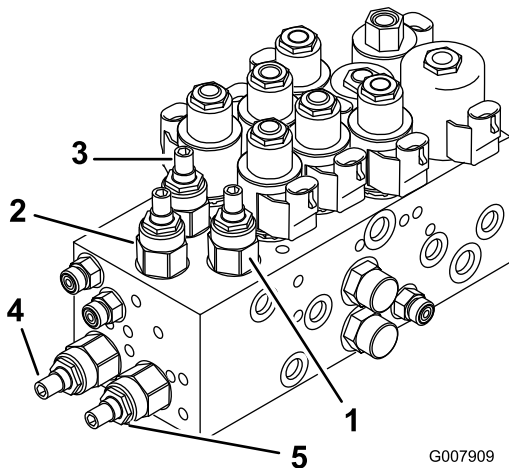

Figure 82

Model 03808 and 03813

1. Adjustment valve for #1 (Front Center) cutting unit
2. Adjustment valve for #4 & #5 (Front Wings) cutting units
3. Adjustment valves for #2 & #3 (Rear) cutting units

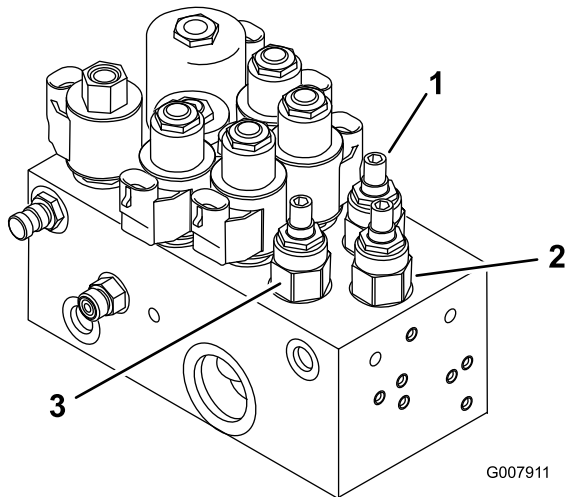

Figure 83

Models 03806, 03807 and 03812

1. Adjustment valve for #1 (Front Center) cutting unit
2. Adjustment valve for #4 & #5 (Front Wings) cutting units
3. Adjustment valves for #2 & #3 (Rear) cutting units
4. Adjustment valve for #6 (Rear Left) cutting unit
5. Adjustment valve for #7 (Rear Right) cutting unit

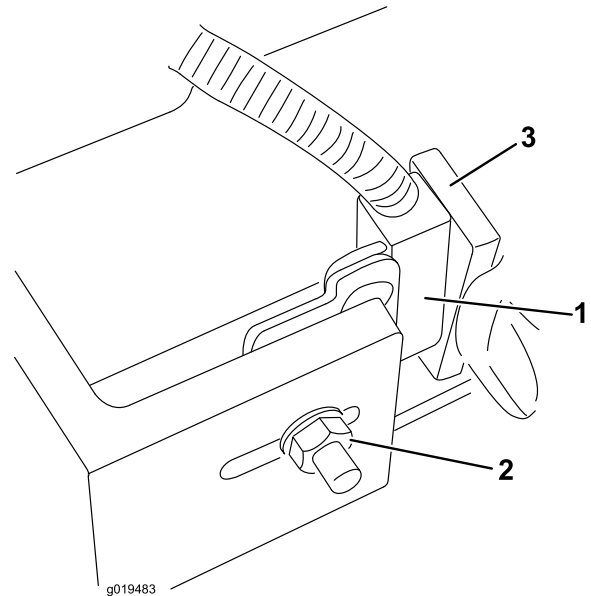

Figure 84

#4 shown

1. Lift arm switch
2. Carriage bolt nut
3. Lift arm flag

2. Loosen the locking nuts on the valves.
3. Using a Allen Head wrench, rotate the appropriate valve clockwise to slow down drop rate of cutting units.
4. Verify the lift rate adjustment by raising and lowering cutting units several times. Readjust as required.
5. Tighten the locking nut to secure the adjustment.

- Move the lift switch bracket up in the slot to the desired position.
- Set the distance between the lift arm switch and the flag on the lift arm to approximately .062 inches.
- Tighten carriage bolt nut.

Adjusting the Travel of the Front Three Cutting Units

Additional downward travel of the front three cutting units may be desirable in highly contoured locations. If any of the front three cutting units lift off the ground when cresting a hill, the front carrier frame may be lowered by removing mounting bolts and repositioning frame in the bottom set of holes in the main frame (Figure 85). Contact your distributor for assistance.

Note: Moving the carrier frame down will decrease the amount of clearance between the cutting units and the ground in turnaround and transport positions and may require adjusting the lift chain length on the cutting unit.

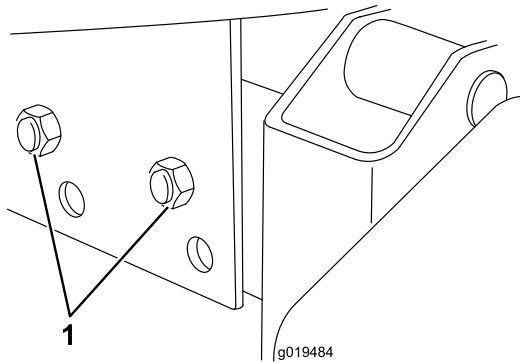

Figure 85

1. Carrier frame mounting bolts
-

Storage

Traction Unit

1. Thoroughly clean the traction unit, cutting units and the engine.
2. Check the tire pressure. Inflate all tires to 15-20 psi.
3. Check all fasteners for looseness; tighten as necessary.
4. Grease or oil all grease fittings and pivot points. Wipe up any excess lubricant.
5. Lightly sand and use touch-up paint on painted areas that are scratched, chipped, or rusted. Repair any dents in the metal body.
6. Service the battery and cables as follows:
 - A. Remove the battery terminals from the battery posts.
 - B. Clean the battery, terminals, and posts with a wire brush and baking soda solution.
 - C. Coat the cable terminals and battery posts with Grafo 112X skin-over grease (Toro Part No. 505-47) or petroleum jelly to prevent corrosion.
 - D. Slowly recharge the battery every 60 days for 24 hours to prevent lead sulfation of the battery.

⚠ WARNING

Charging the battery produces gasses that can explode.

Never smoke near the battery and keep sparks and flames away from battery.

Engine

1. Drain the engine oil from the oil pan and replace the drain plug.
2. Remove and discard the oil filter. Install a new oil filter.
3. Refill oil pan with 7.5 qts. (7 l) of SAE15W-40 CD, CE, CF, CF-4, or CG-4 motor oil.
4. Start the engine and run at idle speed for approximately two minutes.
5. Stop the engine.
6. Flush the fuel tank with fresh, clean diesel fuel.
7. Secure all fuel system fittings.
8. Thoroughly clean and service the air cleaner assembly.
9. Seal the air cleaner inlet and the exhaust outlet with weatherproof tape.
10. Check anti freeze protection and add a 50/50 solution of water and anti freeze as needed for expected minimum temperature in your area.

Schematics

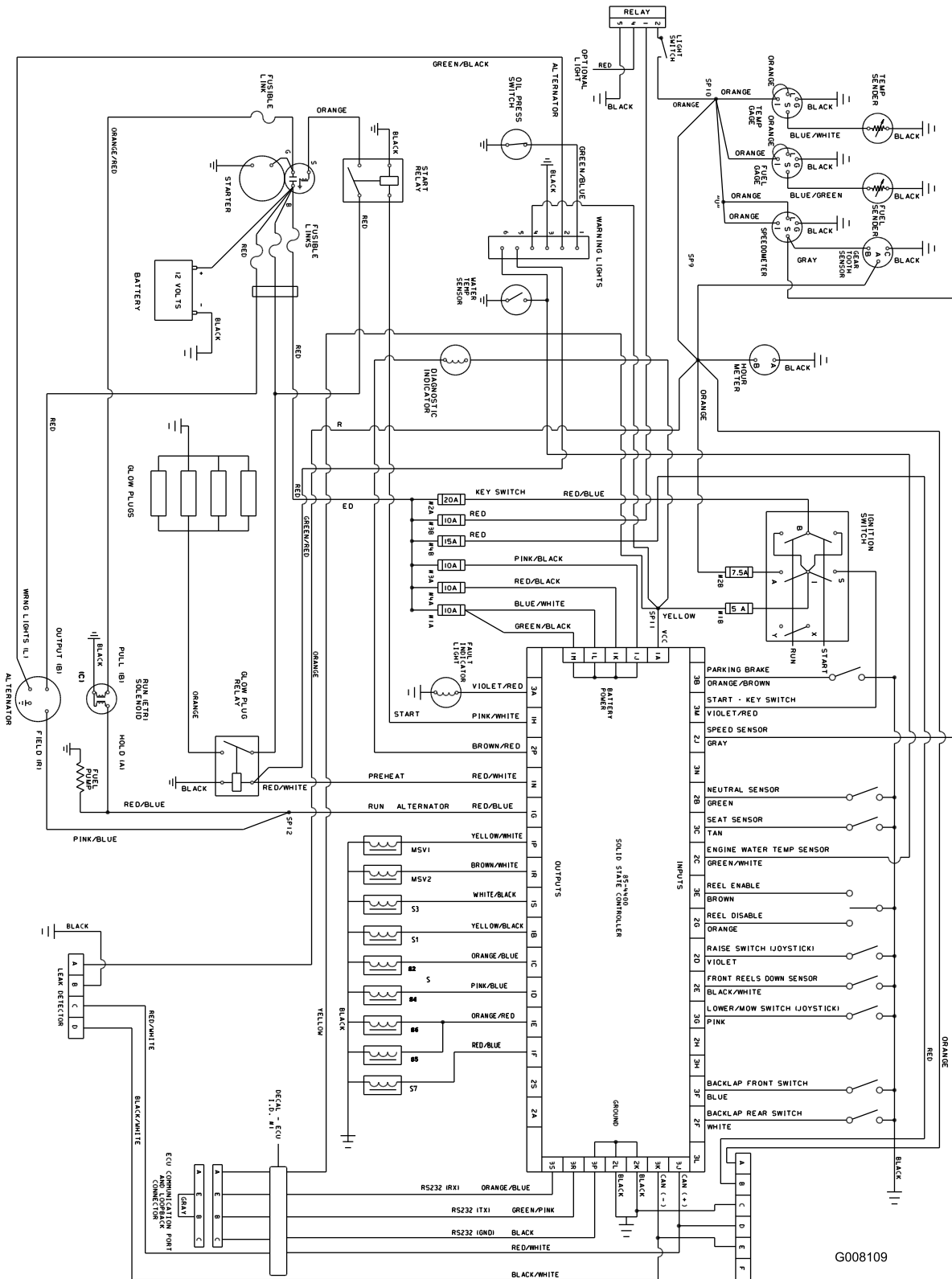

G008109

Electrical Schematic, All models (Rev. A)

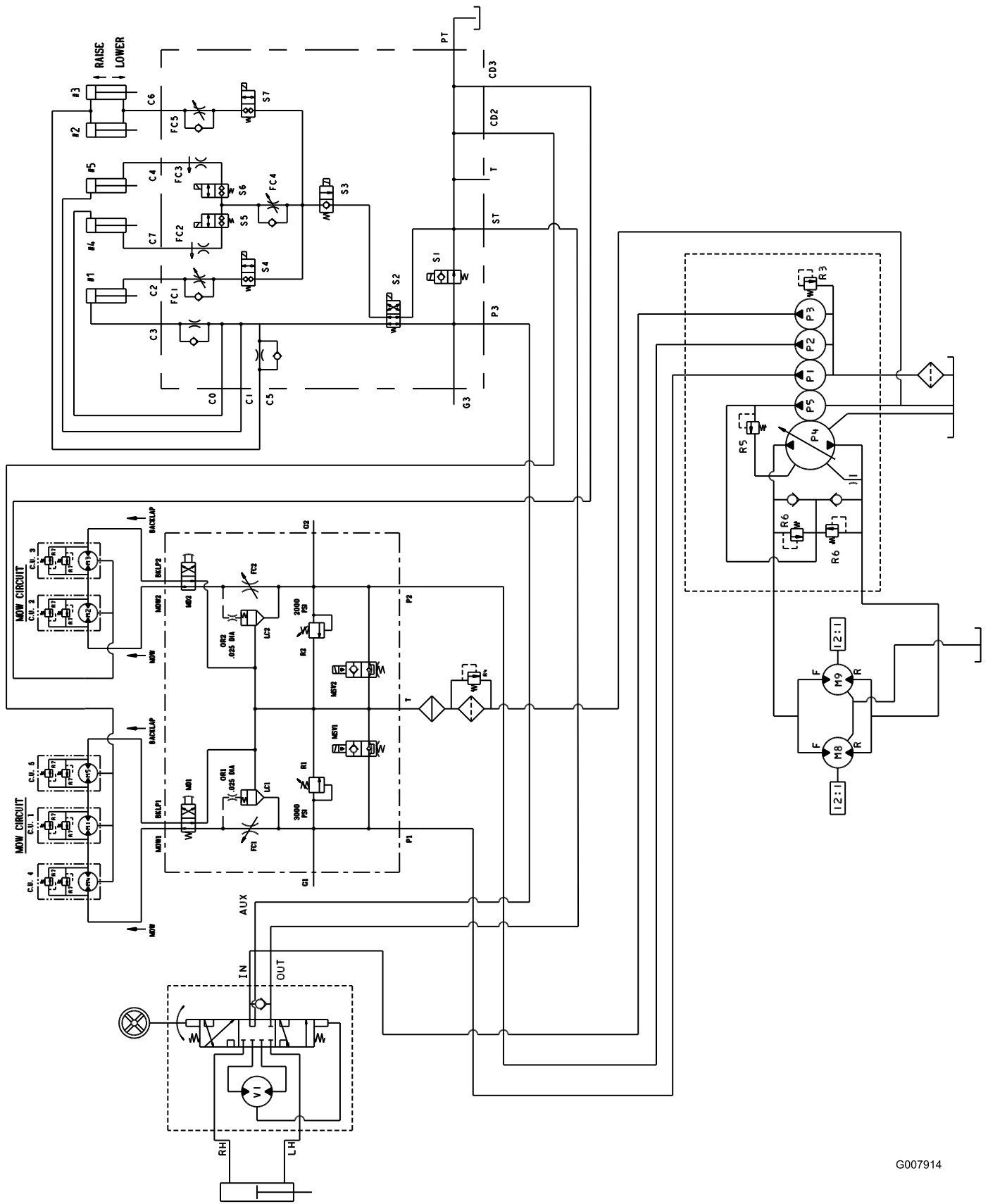

Hydraulic Schematic, Model 03806 (Rev. -)

G007914

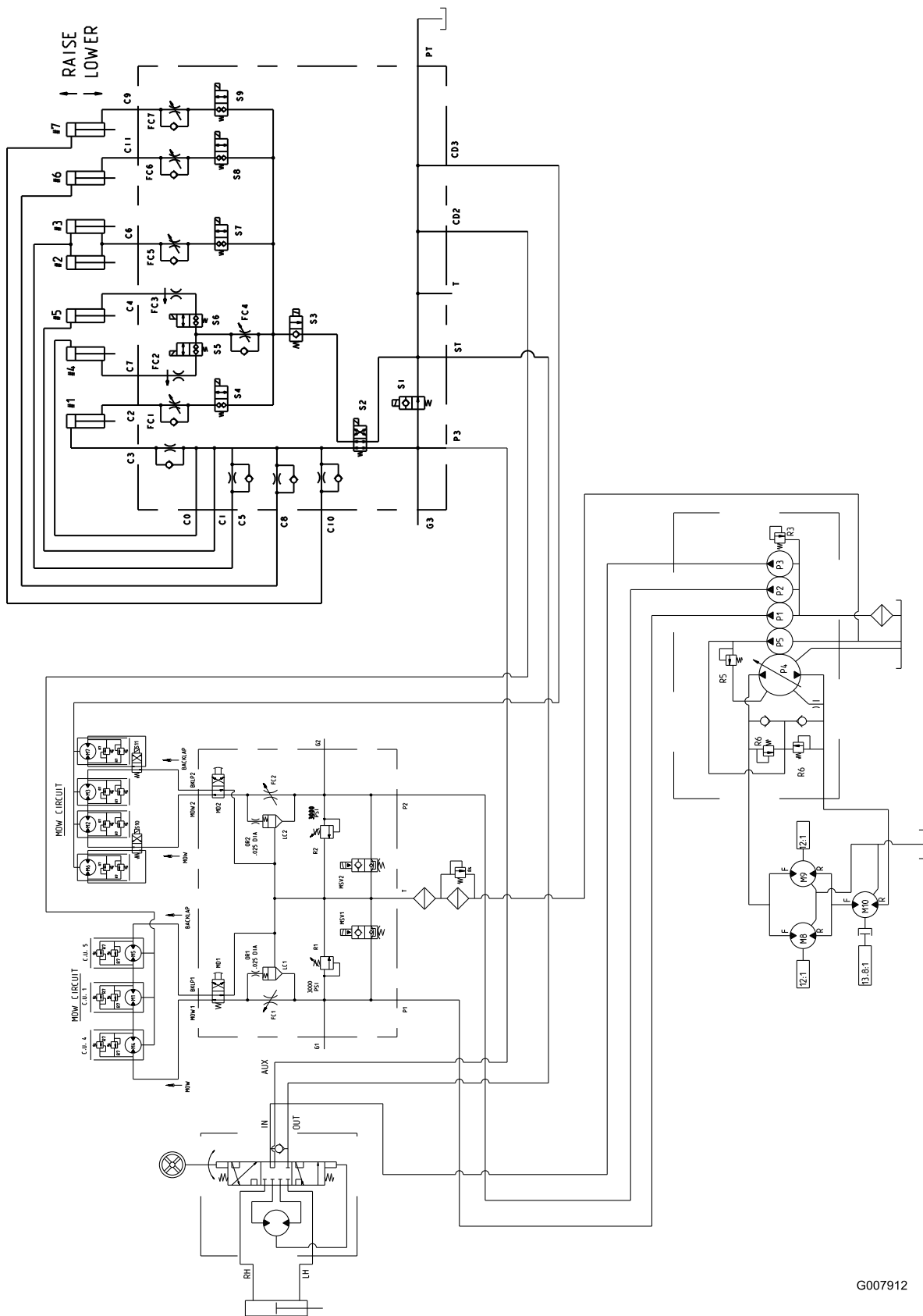

Hydraulic Schematic, Model 03808 and 03813 (Rev. A)

G007912

Notes:



The Toro Total Coverage Guarantee

A Limited Warranty

Conditions and Products Covered

The Toro Company and its affiliate, Toro Warranty Company, pursuant to an agreement between them, jointly warrant your Toro Commercial product ("Product") to be free from defects in materials or workmanship for two years or 1500 operational hours*, whichever occurs first. This warranty is applicable to all products with the exception of Aerators (refer to separate warranty statements for these products). Where a warrantable condition exists, we will repair the Product at no cost to you including diagnostics, labor, parts, and transportation. This warranty begins on the date the Product is delivered to the original retail purchaser.

* Product equipped with an hour meter.

Instructions for Obtaining Warranty Service

You are responsible for notifying the Commercial Products Distributor or Authorized Commercial Products Dealer from whom you purchased the Product as soon as you believe a warrantable condition exists. If you need help locating a Commercial Products Distributor or Authorized Dealer, or if you have questions regarding your warranty rights or responsibilities, you may contact us at:

Toro Commercial Products Service Department
Toro Warranty Company
8111 Lyndale Avenue South
Bloomington, MN 55420-1196
952-888-8801 or 800-952-2740
E-mail: commercial.warranty@toro.com

Owner Responsibilities

As the Product owner, you are responsible for required maintenance and adjustments stated in your *Operator's Manual*. Failure to perform required maintenance and adjustments can be grounds for disallowing a warranty claim.

Items and Conditions Not Covered

Not all product failures or malfunctions that occur during the warranty period are defects in materials or workmanship. This warranty does not cover the following:

- Product failures which result from the use of non-Toro replacement parts, or from installation and use of add-on, or modified non-Toro branded accessories and products. A separate warranty may be provided by the manufacturer of these items.
- Product failures which result from failure to perform recommended maintenance and/or adjustments. Failure to properly maintain your Toro product per the Recommended Maintenance listed in the *Operator's Manual* can result in claims for warranty being denied.
- Product failures which result from operating the Product in an abusive, negligent, or reckless manner.
- Parts subject to consumption through use unless found to be defective. Examples of parts which are consumed, or used up, during normal Product operation include, but are not limited to, brake pads and linings, clutch linings, blades, reels, rollers and bearings (sealed or greasable), bed knives, spark plugs, castor wheels and bearings, tires, filters, belts, and certain sprayer components such as diaphragms, nozzles, and check valves, etc.
- Failures caused by outside influence. Conditions considered to be outside influence include, but are not limited to, weather, storage practices, contamination, use of unapproved fuels, coolants, lubricants, additives, fertilizers, water, or chemicals, etc.
- Failure or performance issues due to the use of fuels (e.g. gasoline, diesel, or biodiesel) that do not conform to their respective industry standards.

Countries Other than the United States or Canada

Customers who have purchased Toro products exported from the United States or Canada should contact their Toro Distributor (Dealer) to obtain guarantee policies for your country, province, or state. If for any reason you are dissatisfied with your Distributor's service or have difficulty obtaining guarantee information, contact the Toro importer.

- Normal noise, vibration, wear and tear, and deterioration.
- Normal "wear and tear" includes, but is not limited to, damage to seats due to wear or abrasion, worn painted surfaces, scratched decals or windows, etc.

Parts

Parts scheduled for replacement as required maintenance are warranted for the period of time up to the scheduled replacement time for that part. Parts replaced under this warranty are covered for the duration of the original product warranty and become the property of Toro. Toro will make the final decision whether to repair any existing part or assembly or replace it. Toro may use remanufactured parts for warranty repairs.

Deep Cycle and Lithium-Ion Battery Warranty:

Deep cycle and Lithium-Ion batteries have a specified total number of kilowatt-hours they can deliver during their lifetime. Operating, recharging, and maintenance techniques can extend or reduce total battery life. As the batteries in this product are consumed, the amount of useful work between charging intervals will slowly decrease until the battery is completely worn out. Replacement of worn out batteries, due to normal consumption, is the responsibility of the product owner. Battery replacement may be required during the normal product warranty period at owner's expense. Note: (Lithium-Ion battery only): A Lithium-Ion battery has a part only prorated warranty beginning year 3 through year 5 based on the time in service and kilowatt hours used. Refer to the *Operator's Manual* for additional information.

Maintenance is at Owner's Expense

Engine tune-up, lubrication, cleaning and polishing, replacement of filters, coolant, and completing recommended maintenance are some of the normal services Toro products require that are at the owner's expense.

General Conditions

Repair by an Authorized Toro Distributor or Dealer is your sole remedy under this warranty.

Neither The Toro Company nor Toro Warranty Company is liable for indirect, incidental or consequential damages in connection with the use of the Toro Products covered by this warranty, including any cost or expense of providing substitute equipment or service during reasonable periods of malfunction or non-use pending completion of repairs under this warranty. Except for the Emissions warranty referenced below, if applicable, there is no other express warranty. All implied warranties of merchantability and fitness for use are limited to the duration of this express warranty.

Some states do not allow exclusions of incidental or consequential damages, or limitations on how long an implied warranty lasts, so the above exclusions and limitations may not apply to you. This warranty gives you specific legal rights, and you may also have other rights which vary from state to state.

Note regarding engine warranty:

The Emissions Control System on your Product may be covered by a separate warranty meeting requirements established by the U.S. Environmental Protection Agency (EPA) and/or the California Air Resources Board (CARB). The hour limitations set forth above do not apply to the Emissions Control System Warranty. Refer to the Engine Emission Control Warranty Statement supplied with your product or contained in the engine manufacturer's documentation for details