

Operating & Maintenance Instructions

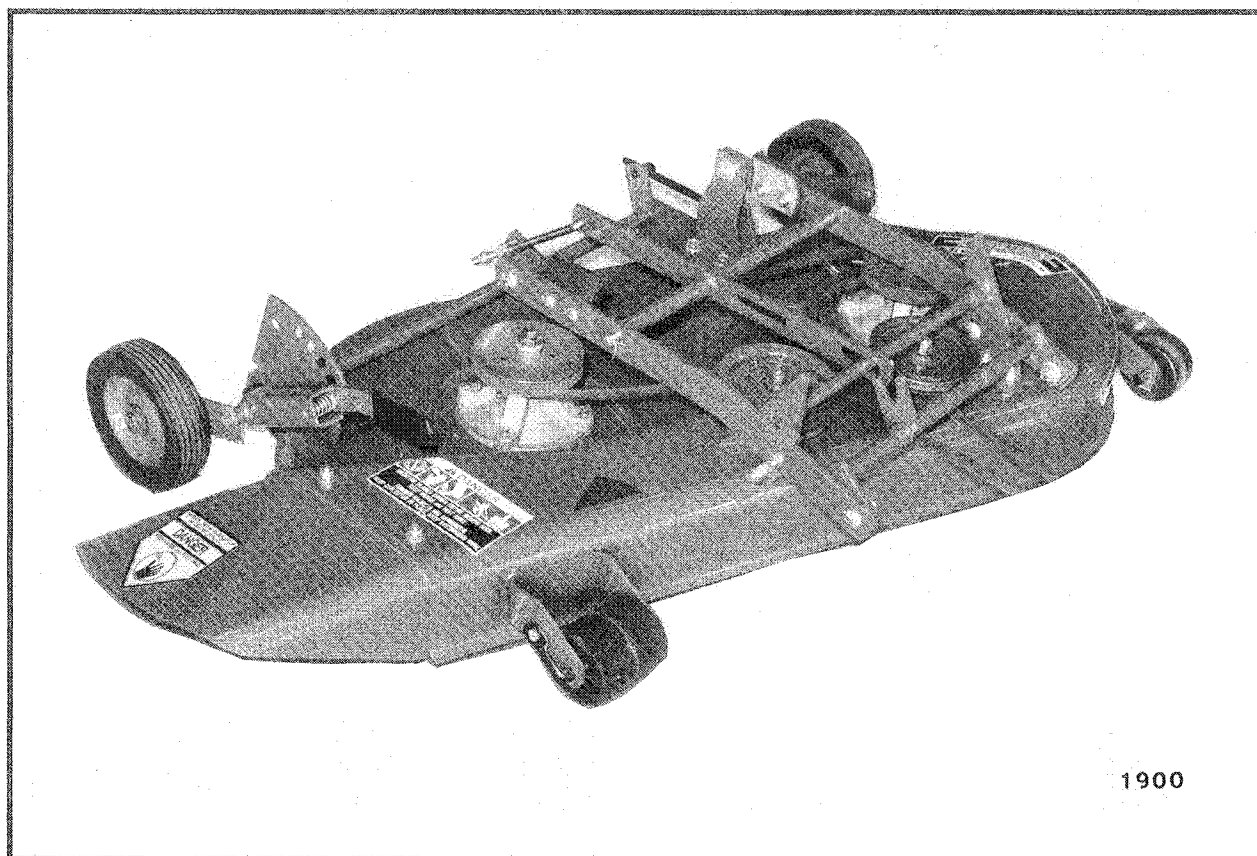

37 in. (94 cm) Side Discharge Mower

300/400-Series
Garden Tractor



Wheel Horse®
Tractors & Riding Mowers

MODEL AND SERIAL NUMBER

A Model and Serial Number identifies your Toro Wheel Horse attachment. These numbers should always be referred to when consulting with your dealer or factory concerning service, replacement parts, or questions you may have. If plate is removed during repair operations it should always be replaced. For your reference, record numbers from Model and Serial Number plate on your attachment.



ASSEMBLY

INSTALLATION

IMPORTANT

Before installation, check that all mower blade nuts are tight:

Blade Nut Torque 80-100 ft. lbs. (112-140 Nm)

Check that mower spindles have been lubricated. Use a pressure grease gun and #2 multi-purpose lithium grease. Grease fittings are on side of spindle housings.

⚠ CAUTION ⚠

Sharp edges of mower blades can cut you during blade maintenance or adjustment. Use suitable covering over cutting edges of blade to prevent bodily harm.

Place mower along right side of tractor. Position height control lever in middle position (Fig. 1).

Turn front wheels of tractor fully left. Raise tractor attachment lift.

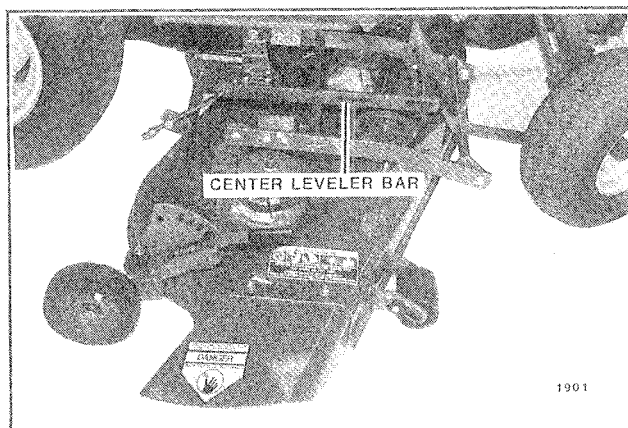

FIG. 1. Prepare Mower For Installation

Slide mower under tractor until mower center leveler bar is directly under right side of tractor frame.

ATTACH MOWER TO TRACTOR

Lower tractor attachment lift. Remove washer and hairpin cotter installed on tractor lift bar pin (Fig. 5). Align lift bar and pin (attached to tractor) with slot in mower leveler bar (Figs. 1 & 2).

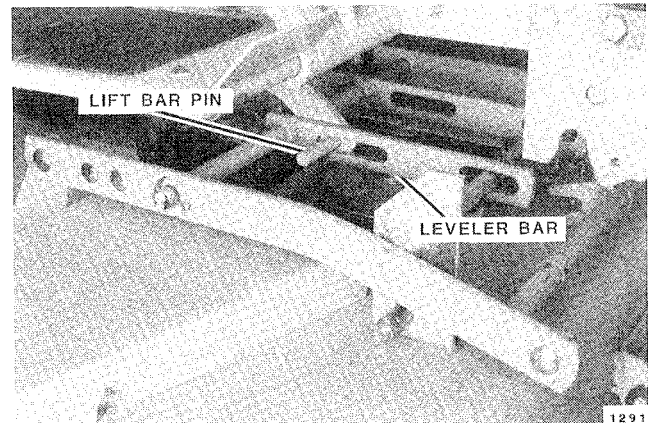

FIG. 2. Align Pin with Slot

Push mower in until it is centered under tractor.

Open mid Attach-A-Matic hitch by pushing release button in and pushing latch lever down (Fig. 3).



FIG. 3. Open Mid Attach-A-Matic Hitch

Adjust mower hitch so fork faces upward. Adjust mower so welded spacers are positioned between tractor hitch plates (Fig. 4).

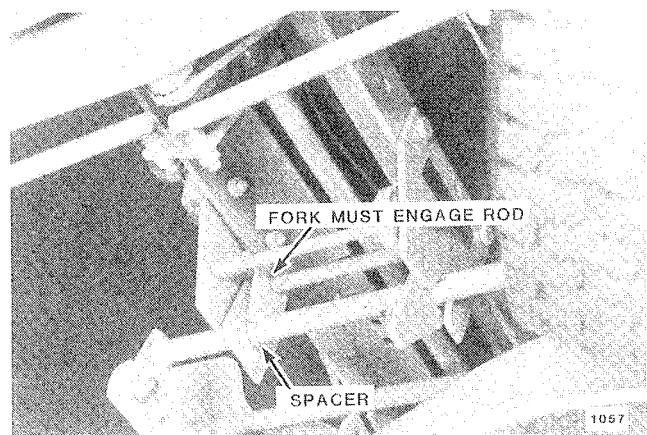

FIG. 4. Align Fork with Shaft

Secure mower to tractor with previously removed washer and hairpin cotter (Fig. 5).

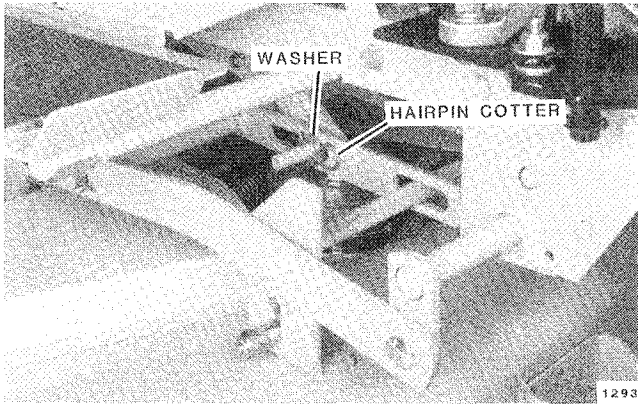

FIG. 5. Secure Mower to Tractor Lift Bar Pin

Lift mower with attachment lift. NOTE: When using a manual attachment lift, be sure lift handle "locks" in raised position.

Close Attach-A-Matic hitch by moving latch lever up.

INSTALL FRONT PULLEY SUPPORT

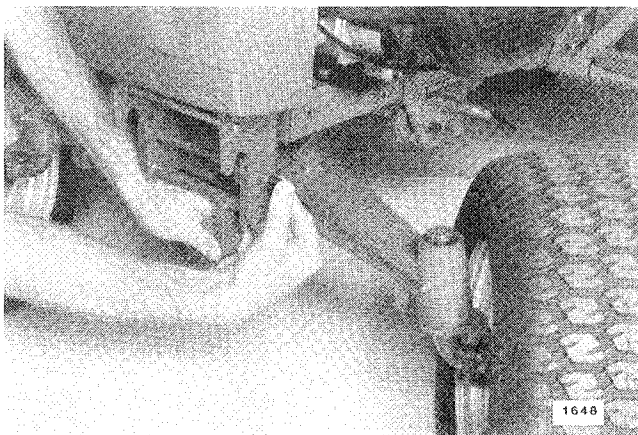

FIG. 6. Open Front Attach-A-Matic Hitch

Open front Attach-A-Matic hitch by pushing release button and pulling forward on latch handle (Fig. 6).

Insert shaft of pulley support assembly into hitch slots and push latch handle rearward to lock latch (Fig. 7).

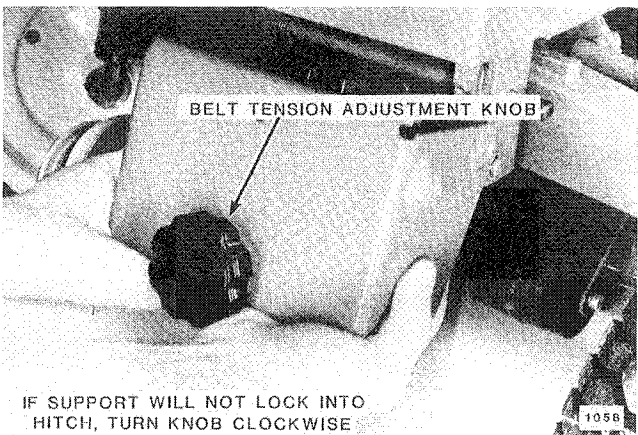

FIG. 7. Install Pulley Support

INSTALL DRIVE BELT AND COVER

Turn belt tension adjustment knob all the way clockwise (Fig. 7).

Install belt through front of mower deck around spindle pulleys with Belt Part Number showing (Figs. 8 & 9). Continue belt strands around front idler pulleys (Figs. 8 & 10). Place drive belt on inside groove of PTO pulley (Fig. 10). **BELT ROUTING IS CRITICAL, MAKE SURE BELT IS ROUTED AS SHOWN IN FIGURE 8.**

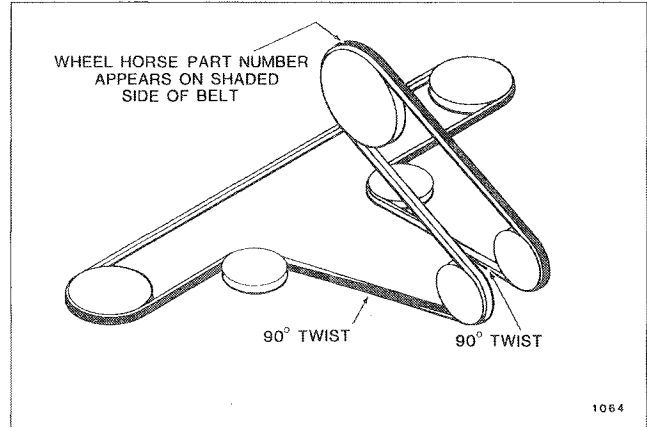

FIG. 8 Mower Drive Belt Routing

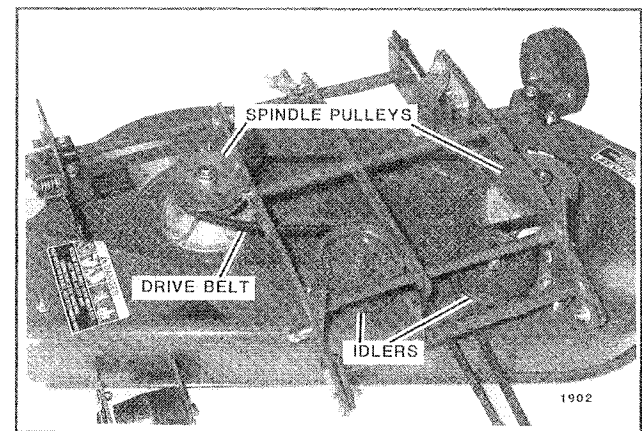

FIG. 9 Mower Drive Belt

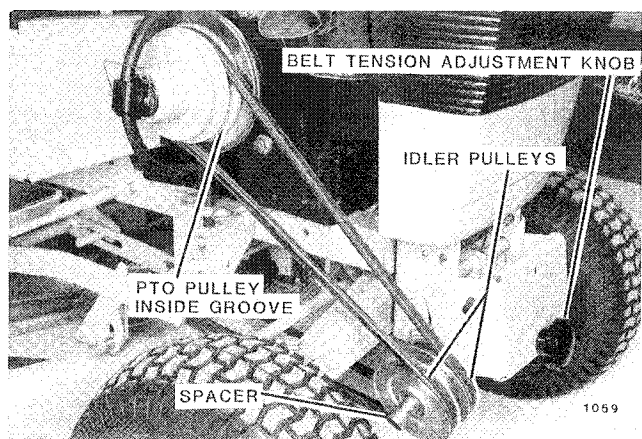

FIG. 10 Mower Front Pulleys

Hold pulleys in against thrust collar and adjust drive belt tension by turning adjusting knob counterclockwise until top strand of drive belt can be depressed approximately 1 inch

(2.5 cm) under moderate finger pressure at mid-point between pulleys (Fig 10).

Remove cover nut making sure spacer remains on shaft (Fig. 11). Install cover with pilot pin in slot of support (Fig. 12). Reinstall cover nut and tighten.

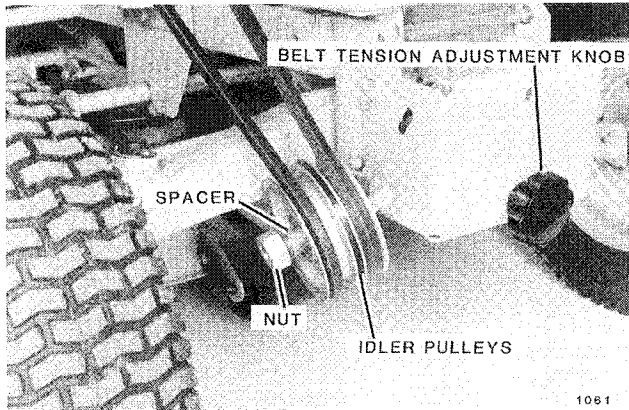

FIG. 11 Mower Front Idler Pulleys

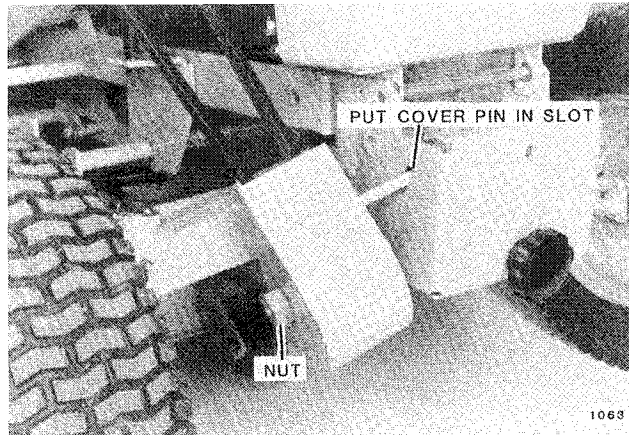

FIG. 12. Install Pulley Support Cover

CHECKING MOWER LEVEL

For optimum efficiency, level of mower should be checked at time of initial installation and periodically as a check, to see if alignment is maintained.

MOWER LEVEL

Position tractor on a level surface. Adjust all four tires to 12 PSI pressure. Place mower height control lever in middle cutting position.

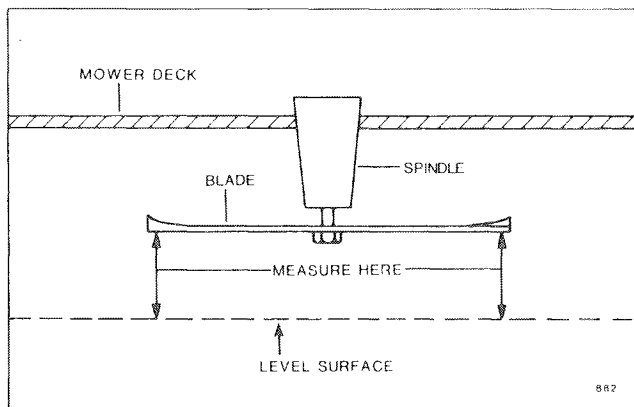

FIG. 13. Mower Level Measurement

Turn mower blades side-to-side. Adjust distance from surface to blade tips equal (Figs. 13 & 14).

Turn mower blades front-to-rear. Adjust so that distances from surface to front and rear of blade tips are equal to 1/8 inch high in front (Figs. 13, 14 and 15).

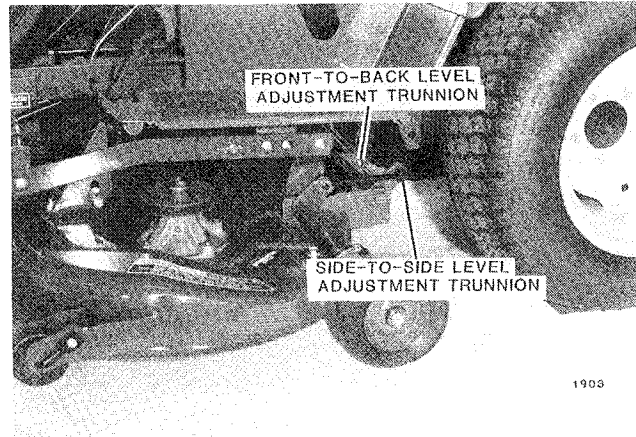

FIG. 14. Level Adjustments

Under some unusual mowing conditions, mower may leave a "streak" of uncut grass, which can be caused by any of the following conditions:

1. Engine being operated at less than full throttle.
2. Dull blades or underside of mower deck clogged with matted grass.
3. Ground speed too high for conditions - adjust to 2 mph (3.2 kph), or less if necessary.
4. Striking on turns indicates turns are being made too sharply.
5. If blades have been sharpened a number of times, they may now be too short to "overlap" each other, and must be replaced.

If streaking persists after the above possibilities have been eliminated as cause, adjust mower until deck is level, then turn adjustment nut "in" (clockwise) one complete turn, to shorten level adjustment rod and slightly raise front of mower.

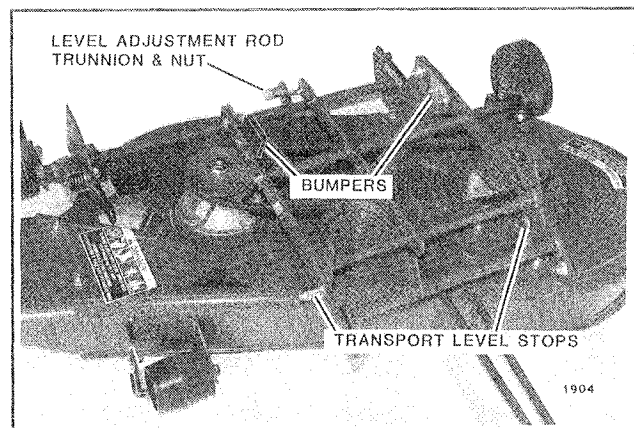

FIG. 15. Mower Adjustments

TRACTOR LIFT BAR - TRUNNION AND LIFT ROD ADJUSTMENT

This adjustment involves parts located on tractor (Fig. 16). Trunnion on lift chain should be adjusted so that bumpers on draft bars of mower suspension come in contact with tractor footrests when mower is fully raised (Fig. 15), with trunnion stud in rear hole of tractor lift lever.

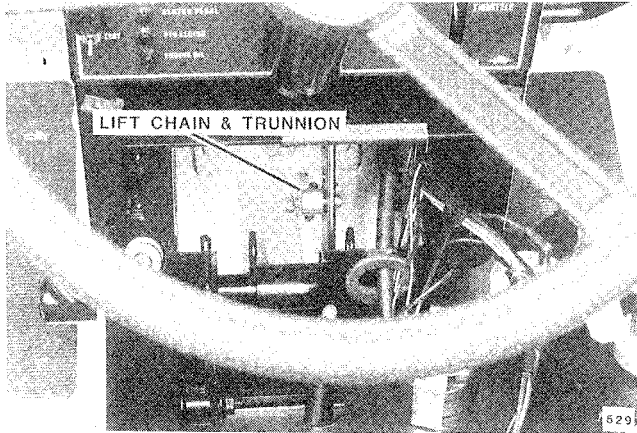

FIG. 16. Tractor Lift Bar Trunnion and Lift Rod Adjustment

TRANSPORT LEVEL STOP ADJUSTMENT

For normal operation mower level stops should be adjusted so that carriage bolt heads are set at bottom of bracket slots. If mower is not level, in fully raised position, level stops may be adjusted by moving them in bracket slots as required (Fig. 15).

REMOVAL

Set mower height control lever in lowest cutting position and lower mower with tractor lift. Turn front wheels all the way left.

Turn drive belt tension adjustment knob clockwise all the way and remove belt from mower.

Push mid-hitch lock release button in and open latch, releasing mower hitch shaft.

Remove hairpin cotter and washer from lift bar pin. Slide mower right until lift bar pin comes out of slot in leveler bar. Raise tractor lift.

Remove drive belt from PTO clutch pulley. Remove pulley support assembly by pushing front hitch lock release button in and opening latch. Drive belt need not be removed from pulley support assembly.

Slide mower out from under right side of tractor.

OPERATION



Keep shields and mower discharge chute in place. Never attempt to clear discharge areas or mower blades, or make any adjustments or repairs, without first disengaging PTO clutch/brake and removing ignition key.

IMPORTANT

Every time mower is installed, check for proper operation of PTO clutch and brake. Adjustment of PTO is covered in tractor Operator's Manual. First time mower is used, or after installing a new mower drive belt, recheck belt tension after first 20 minutes of operation (allow belt to cool before checking tension).

1. Disengage tractor PTO clutch and start engine. Lift mower with tractor to remove weight of mower from gage wheels. **NOTE:** Never stand or rest your feet on mower.

2. Move mower height control lever to hole on quadrant corresponding to desired cutting height. This can be set for cutting heights between 1-1/2 and 3-1/2 in. (4 - 9 cm). Recommended cutting height is 2 to 3 inches (5-7.6 cm) for most mowing situations.

3. Lower mower and set engine speed at full throttle. Engage PTO clutch. Regulate ground speed with transmission to 2 - 3.5 mph (3.2 - 5.6 kph)* for best cutting results on average lawns. Uneven cutting often results from excessive ground speed. To correct, reduce ground speed with transmission while maintaining full throttle setting.

4. To mow extra tall grass, raise mower to its highest position for a first cutting and use a slow ground speed. Then re-cut to normal height.

*Average walking speed is 2.5 mph (4 kph).

MAINTENANCE AND STORAGE

LUBRICATION

Mower spindle bearings should be lubricated at 50 operating hour intervals. Use a pressure type grease gun and #2 multi-purpose lithium grease to lubricate spindle bearings. Four to six pumps of a hand type grease gun will usually fill each spindle after 50 hours use. Grease fittings are conveniently located on side of spindle housings (Fig. 17). Lubricate mower gage wheels every 25 hours.

Lubricate pivoting arms and levers at 25 hour intervals with light machine oil applied directly to wear surfaces. Anti-scalp rollers should NOT be lubricated.

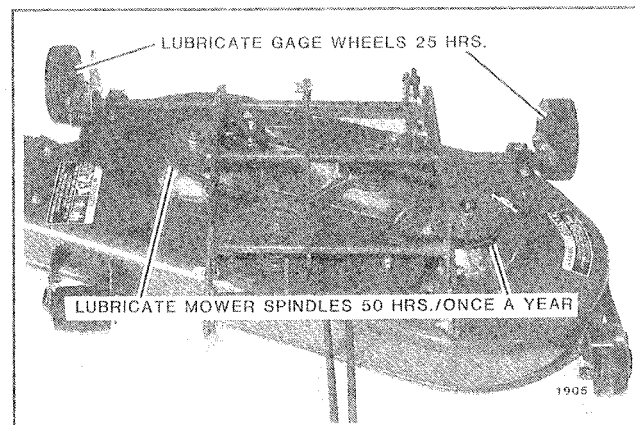

FIG. 17. Mower Lubrication Fittings

BLADE MAINTENANCE



Sharp edges of mower blades can cut you during blade maintenance or adjustment. Use suitable covering over cutting edges of blade to prevent bodily harm.

To obtain optimum mowing results, mower blades should be kept sharp and well balanced. To sharpen blades, remove mower from tractor, invert mower and remove blades. Hold spindle hex with wrench while removing blade attaching nuts and washers from end of spindles.

File or grind blades evenly. Take care to retain angle of original cutting edge. Blade balance can be checked on an inexpensive blade balancer, available at most hardware stores.

Reinstall blades with lift area (turned up section) facing mower deck. Tighten blade attaching nuts to a torque of 80-100 ft. lbs. (112-140 Nm).

UNDERSIDE CLEANING

It is of vital importance to clean underside of mower deck frequently. Accumulation of matted clippings seriously impairs mower's ability to "lift" grass blades into cutting position and discharge clippings evenly. Matted grass clogging underside of mower is often times a cause of uneven cutting.

REPLACEMENT BELTS

Be sure to purchase genuine Toro Wheel Horse belts for replacement purposes as these belts are designed specifically for each application.

MOWER DRIVE BELT REPLACEMENT (Refer to Figures 7 thru 12)

Turn belt adjustment knob all the way clockwise.

Remove belt front pulley cover retaining nut and remove cover being careful not to lose pulley cover spacer. Reinstall nut finger tight to avoid possibility of pulleys and spacers coming off.

Remove belt from PTO, mower and idler pulleys and examine condition of pulleys making sure pulley grooves and bearings are in good condition.

Install replacement belt and adjust tension as outlined under "Install Drive Belt and Cover" section in this manual.

GENERAL CARE AND STORAGE

Top of mower deck should be washed with a garden hose after each use. A mild automotive detergent may be used to remove stubborn dirt. After washing, allow mower to dry, then start tractor and engage mower for approximately one minute to remove excess water from belts and pulleys.

Touch-up painted surfaces with a fresh coat of "Toro Wheel Horse Red", available from your authorized Toro Wheel Horse dealer in aerosol cans.

Store mower in a clean, dry place or protect it with a weather-proof cover when stored outdoors.

A separate parts manual for your Toro Wheel Horse attachment can be obtained by completing the attached form below. You will receive an invoice with manual.

**PUBLICATIONS
TORO WHEEL HORSE
8111 Lyndale Ave. So.
Bloomington, Minnesota 55420**

PARTS MANUAL ORDER FORM

Enter number shown on your attachment:

MODEL	
SERIAL	
TORO Wheel Horse 515 WEST IRELAND ROAD SOUTH BEND, INDIANA 46614 USA	

MAIL LABEL -- PLEASE PRINT CLEARLY

TO:

Name _____

Address _____

City

State

Zip

Product information and specifications are shown herein as of the time of printing. Toro Wheel Horse reserves the right to change product specifications, designs and standard equipment without notice and without incurring obligation.



Wheel Horse®

Tractors & Riding Mowers