

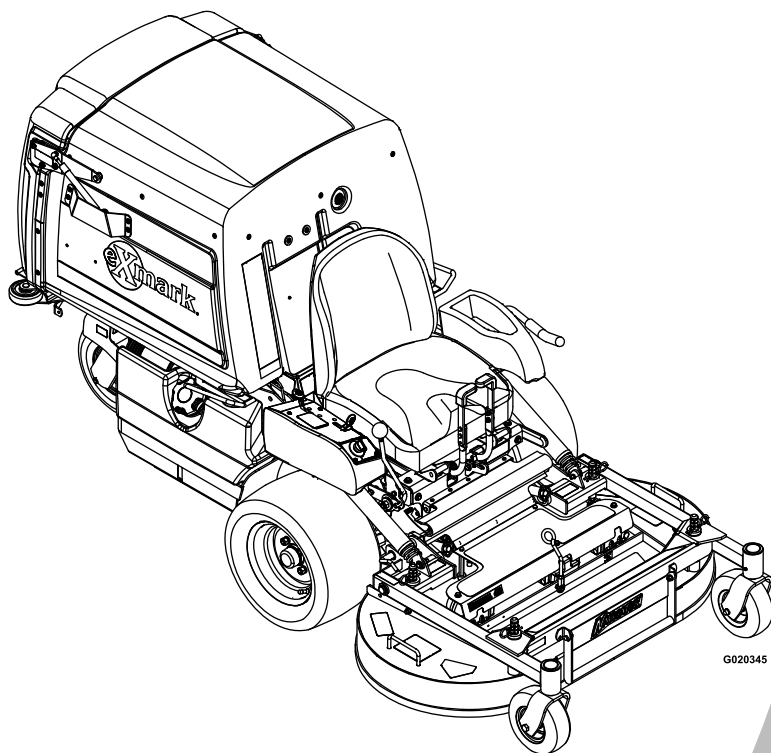

NAVIGATOR®

Model No. NV730EKC42—Serial No. 31300000 and Up

Picture below may not reflect actual product.



Parts Manual

Part No. 4501-548 Rev. C

Ordering Replacement Parts

To order replacement parts, please supply the part number, the quantity, and the description of each part desired.

Understanding Reference Numbers

Each identified part in an illustration has a reference number. The reference number for a part also appears in the parts list, along with other information about the part.

This catalog uses two special reference number formats, one to indicate parts in a service assembly and another to indicate the quantity of a given part in an illustration.

Service Assembly Reference Numbers

Parts in service assemblies have reference numbers in the form a:b. The a represents the reference number of the entire service assembly and the b represents a sequential number unique to each part within the service assembly.

For example, a wheel assembly might be identified by reference number 6, the tire by 6:1, the valve by 6:2, and the wheel by 6:3. When you order the assembly identified by reference number 6, you receive all parts identified by reference numbers 6:1, 6:2, and 6:3. However, you may also order any part individually. Reference numbers of this type appear in illustration and in parts lists.

Reference Numbers Indicating Quantity

In an illustration, if a reference number indicates more than one part, the reference number has the form nX y. The n represents the quantity of the part, the X is the multiplication symbol, and the y represents the reference number.

For example, in an illustration, the reference number 2X 37 means that two of the parts identified by reference number 37 are indicated.

List of Abbreviations

AR: as required	HJ: hex jam	PRH: phillips round head
ASM: assembly	HLH: hex lag head	PTH: phillips truss head
BBC: blade brake control	HOC: height-of-cut	PTO: power-take-off
BHTF: button head thread forming	HSBH: hex socket button head	RH: right hand
CARR: carriage	HSFH: hex socket flat head	ROPS: roll-over protection system
CCW: counter clockwise	HSH: hex socket head	RRB: rear roller brush
CW: clockwise	HWH: hex washer head	SFH: slotted fillister head
DEG: degrees	HWHTF: hex washer head thread forming	SHH: slotted hex head
DPA: Dual Point Adjustment	HYD: hydraulic	SHWH: slotted hex washer head
ECM: electronic control module	LH: left hand	SPH: slotted pan head
EXT: external	LP: Liquefied Petroleum Gas	SQH: square head
FH: flat head	LPG: Liquefied Petroleum Gas	SRH: slotted round head
GA: gauge	NI: nylon insert	STD: standard
HD: heavy-duty	NPTF: national pipe thread fine	TAP: self tapping
HF: hex flange	PFH: phillips flat head	TTH: torx truss head
HH: hex head	PPH: phillips pan head	
HHF: hex head flange	PPHTF: phillips pan head thread forming	
HHFTF: hex head flange thread forming		

Touch Up Paint

Exmark black touch up spray paint – gloss black.

Exmark red touch up paint (spray paint – P/N 1-850337 - .6 oz liquid bottle – P/N 103-9140).



If your Exmark dealer does not have the Exmark part in stock, Exmark will get the parts to the dealer the next business day or the part will be FREE Guaranteed!! (Some restrictions apply. See your participating Exmark Dealer for details.)

Contents

Complete Deck and Support Frame Assembly	4
Deck Assembly	5
Deck W/Decals Assembly No. 109-4373	7
Gearbox Assembly No. 103-3460	8
Discharge Tube Assembly No. 103-9487	9
Rear Deck Height Adjustment Assembly No. 109-0322	10
Deck Support Frame Assembly	11
Deck Support W/Decals Assembly No. 103-9481	12
Spring Lift Assist Assembly No. 109-1979	13
Seat and Consoles Assembly	14
Main Frame Assembly	15
Park Brake Assembly	17
Speed Control Assembly	18
Fuel Assembly	20
Blower Assembly	21
Complete Blower Assembly No. 116-9649	22
Jackshaft Assembly	23
Engine Assembly	25
Hydraulic Assembly	26
Hopper Assembly	28
Hopper Assembly No. 103-9457	29
Hopper Screen Assembly No. 109-0717	30
Hopper Door Assembly No. 103-9456	31
Hopper Frame Assembly No. 109-4086	32
Fill Sensor Assembly No. 103-9466	33
Electrical Assembly	34

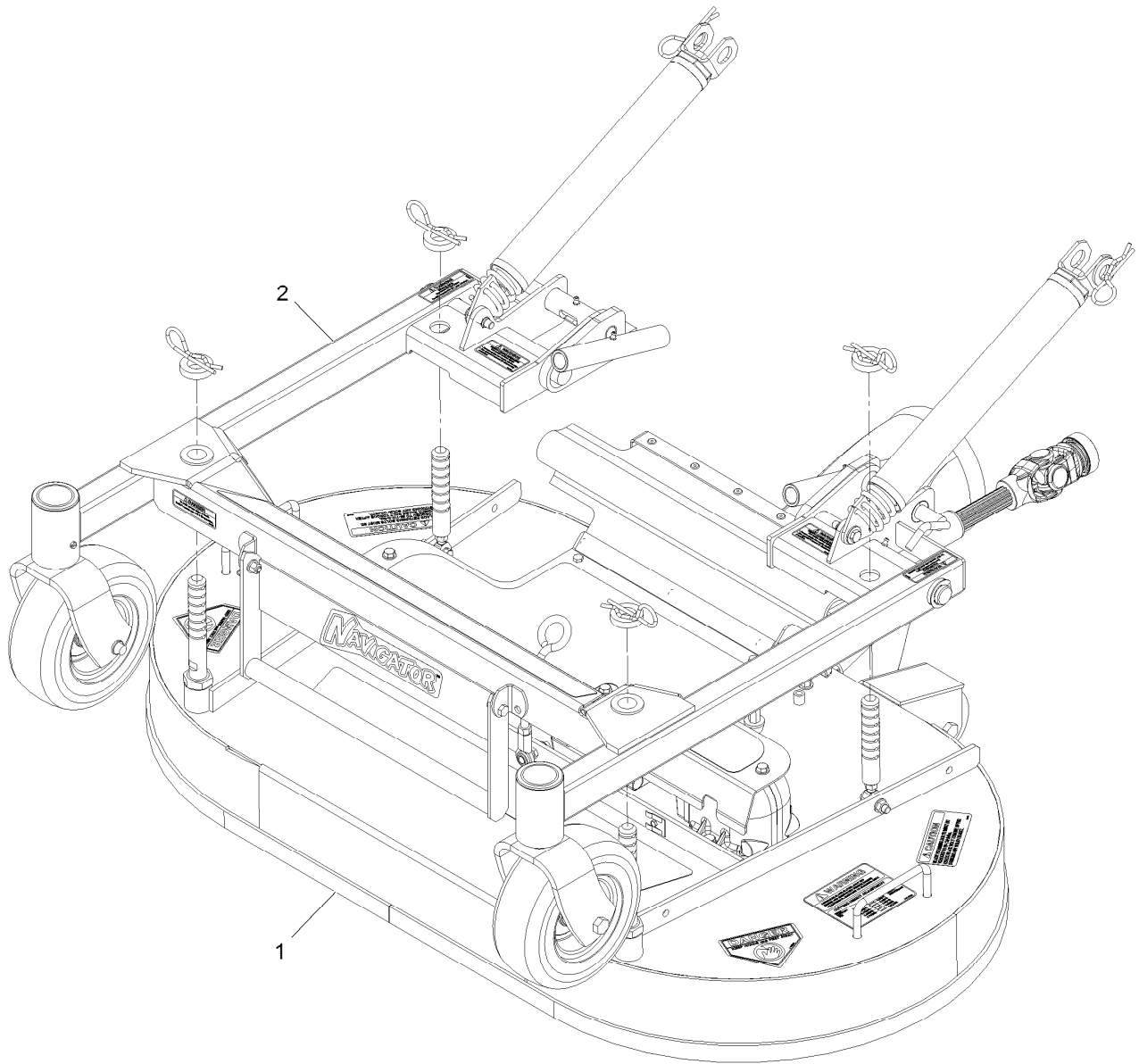

Complete Deck and Support Frame Assembly

<i>Ref.</i>	<i>Part Number</i>	<i>Qty.</i>	<i>Description</i>
1	116-7832	1	Deck ASM
2	116-7840	1	Deck Support Frame ASM

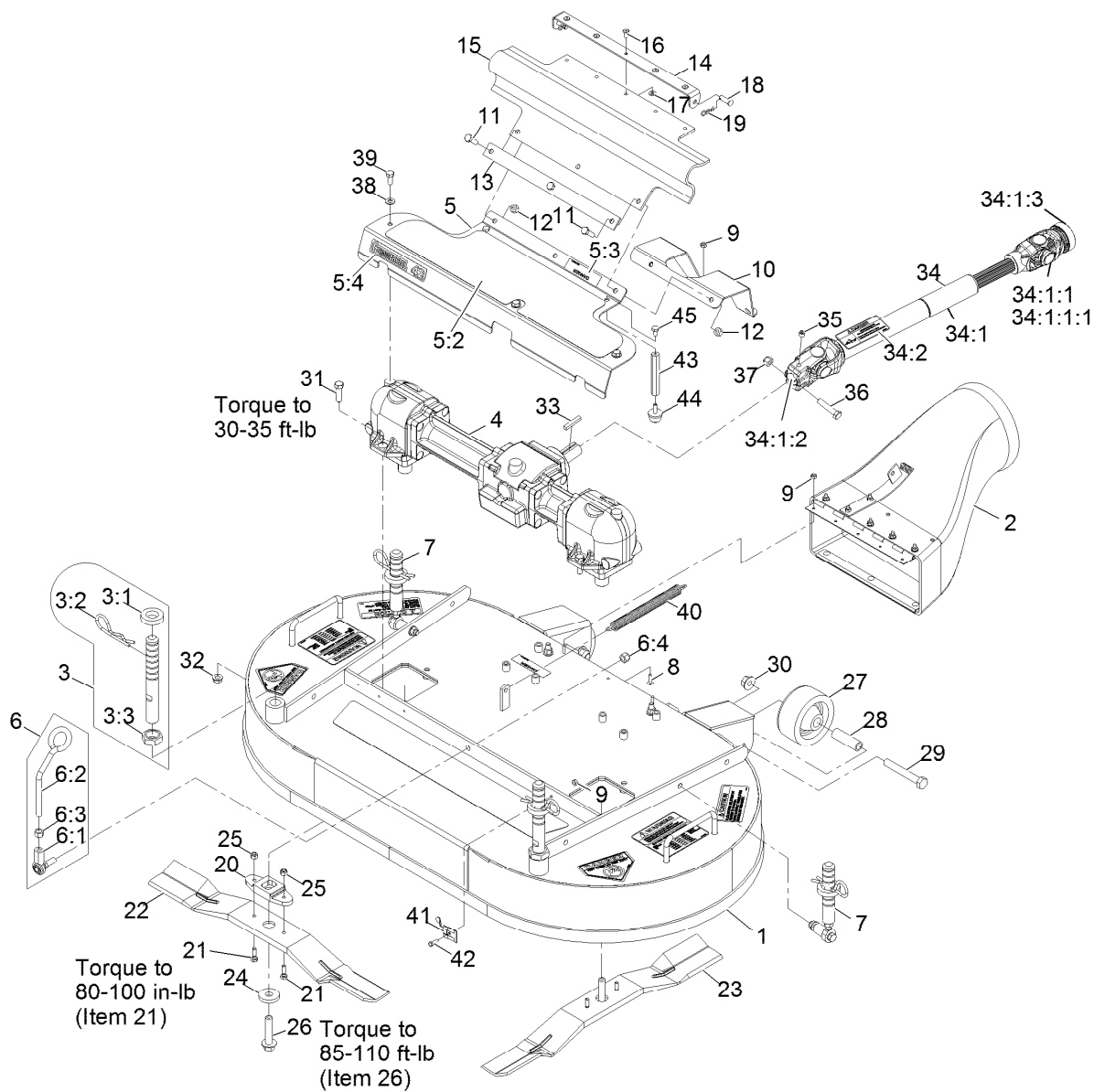

Deck Assembly

Ref.	Part Number	Qty.	Description	Ref.	Part Number	Qty.	Description
1	109-4373	1	Asm, Deck W/Decals (42")	8	1-803075	3	Screw-Truss Head #10-24 X 3/4
2	103-9487	1	Asm, Discharge Tube	9	3296-2	6	Nut-Nyloc #10-24
3	109-0321	2	Asm, Front Deck Height Adj	10	116-7842-01	1	Guard, Drive Shaft -42 Nav
3:1	1-413425	1	Spacer	11	322-5	3	Screw-HH 5/16-18 X 1
3:2	103-7353	1	Pin, Cut Height	12	3296-29	3	Nut-Nyloc 5/16-18
3:3	103-8496	1	Nut-Jam 7/8-9	13	103-6290-03	1	Plate, Drive Line Cover
4	103-3460	1	Gearbox,(42") Std	14	103-6183-03	1	Bracket, PTO Guard
5	103-9497	1	Asm, Gearbox Cover W/Decal (42")	15	103-5979	1	Guard, PTO
5:2	103-8626	1	Pad, Anti Skid (42")	16	114439	5	Rivet
5:3	98-5954	1	Decal-Cover, Missing	17	3256-14	5	Washer-#10 Std
5:4	103-9024	1	Decal, Commercial (42")	18	1-808280	2	Pin-Clevis 5/16 X 1 49/64
6	103-8363	1	Asm, Deck Latch	19	1-806003	2	Hairpin-Cotter
6:1	103-7994	1	Balljoint	20	103-7705	2	Driver, Blade
6:2	103-8307	1	Latch, Deck	21	99-0283	4	Bolt-Shear 1/4-20 X 7/8
6:3	3219-3	1	Nut-Hex 3/8-24	22	103-4210	1	Blade, RH (42") Red
6:4	3296-6	1	Nut-Nyloc 3/8-24	23	103-4209	1	Blade, LH (42") Black
7	109-0322	2	Asm, Rear Deck Height Adj. (42")	24	30-8770	2	Washer
				25	3296-42	4	Nut-Nyloc 1/4-20

● Not serviced separately

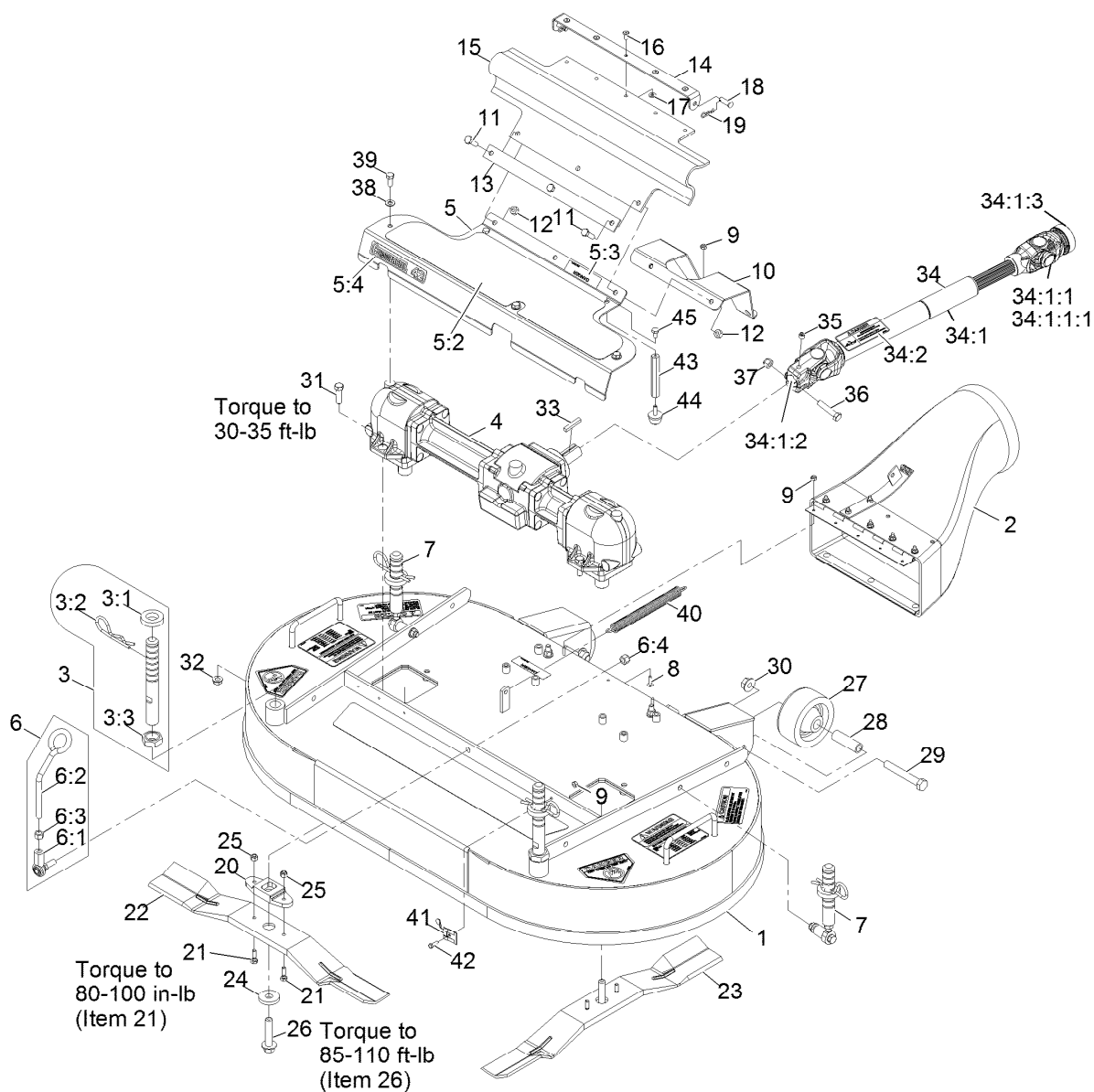

Deck Assembly (continued)

Ref.	Part Number	Qty.	Description	Ref.	Part Number	Qty.	Description
26	92-5816	2	Bolt-Blade 1/2-20 X 2 1/4	34:1:3	103-9329	1	Yoke-Quick Disconnect
27	103-3700	2	Roller, Deck	34:2	103-8425	1	Decal, Driveline
28	103-4230	2	Spacer, Roller	35	3247-2	1	Setscrew-3/8-16 X 3/8
29	325-14	2	Screw-HH 1/2-13 X 3 1/2	36	323-9	1	Screw-HH 3/8-16 X 1 3/4
30	32128-49	2	Nut-Whizlock 1/2-13	37	3296-39	1	Nut-Nyloc 3/8-16
31	323-7	4	Screw-HH 3/8-16 X 1 1/4	38	3256-23	3	Washer-5/16 Sae
32	3290-357	4	Nut-Whizlock 3/8-16	39	322-3	3	Screw-HH 5/16-18 X 3/4
33	67-7490	1	Key-Machine 1/4 X 1/4 X 1 1/2	40	103-8841	1	Spring
34	103-9485	1	Asm, Drive Shaft W/Decal	41	1-513690	1	Clip, Deck Hold-Up Rod
34:1		1	Shaft, Drive Telescoping ●	42	3290-134	1	Screw-HH Machine 10-24 X 5/8
34:1:1	54-9180	2	U-Joint Kit	43	103-8610	2	Stand-Off, 1/2 Hex
34:1:1:1	62-3820	1	Fitting-Grease	44	1-523420	2	Bumper
34:1:2	103-9328	1	Yoke, Keyed	45	321-2	2	Screw-HH 1/4-20 X 1/2

● Not serviced separately

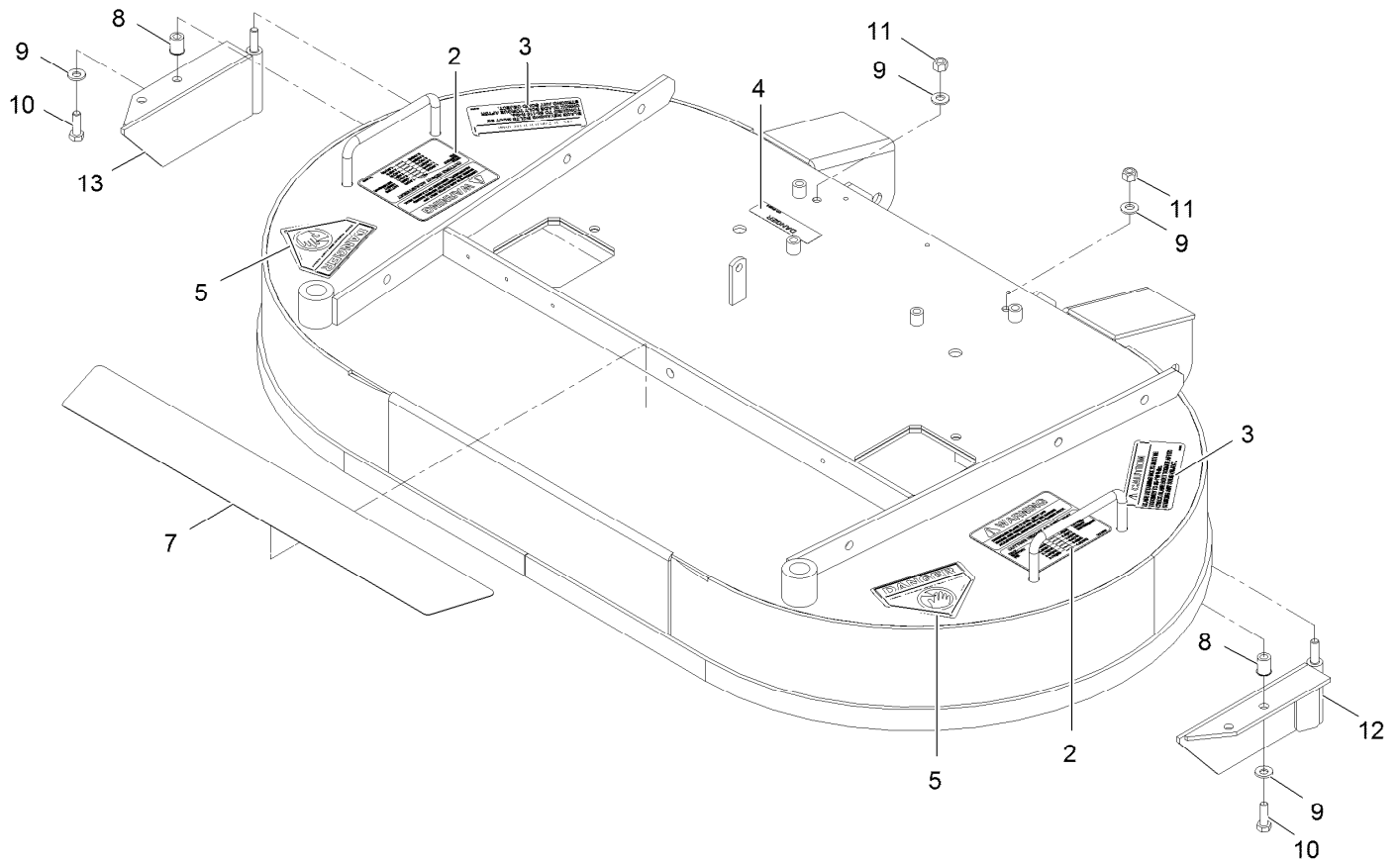

Deck W/Decals Assembly No. 109-4373

Ref.	Part Number	Qty.	Description
2	103-6230	2	Decal, Cutting Height Adjustment
3	68-8340	2	Decal-Torque
4	98-5954	1	Decal-Cover, Missing
5	1-403005	2	Decal-Danger
7	103-8667	1	Pad, Anti Skid (42")
8	32148-7	6	Nut-Insert
9	1-303334	4	Washer-Spring Disc 5/16
10	322-5	2	Screw-HH 5/16-18 X 1
11	3296-29	2	Nut-Nyloc 5/16-18
12	109-4053-01	1	Wld, Baffle Discharge LH
13	109-4054-01	1	Wld, Baffle Discharge RH

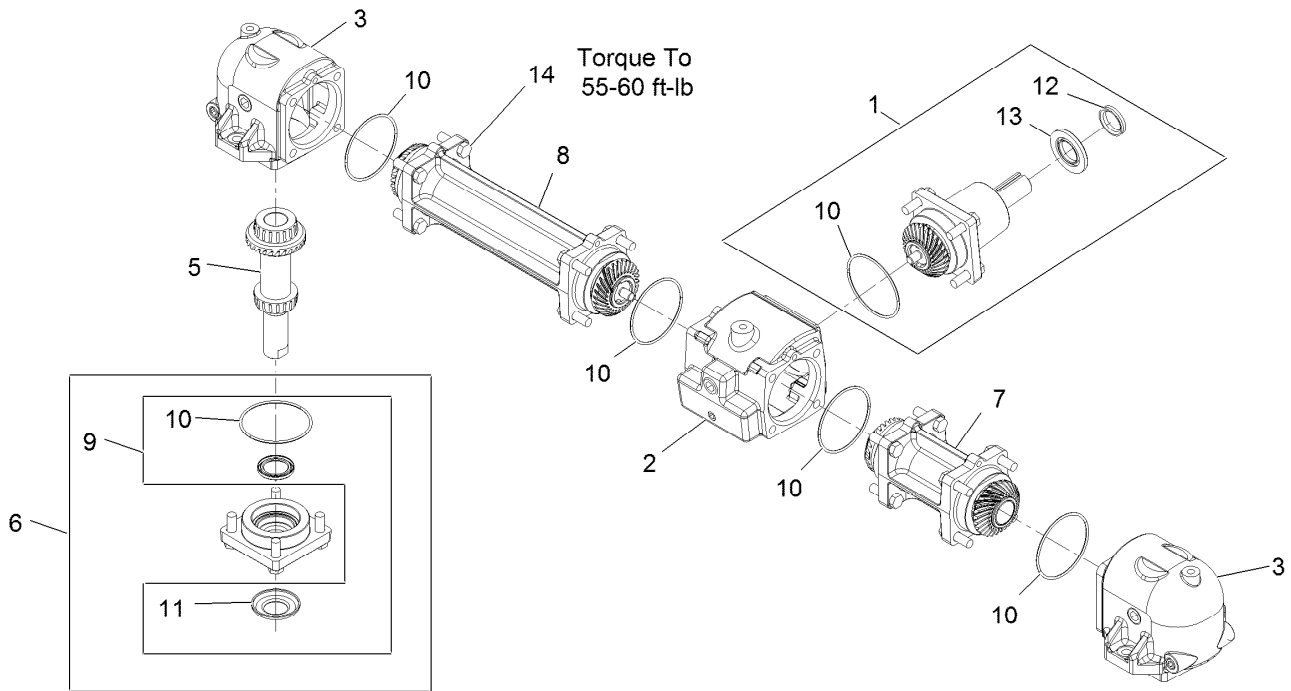

Items #2, #3, #7 and #8 include O-rings Item #10.
 Items #4 and #5 Include Output Seal Kit Item #9.
 Item #1, #6, #7, and #8 Do Not Include Item #14.

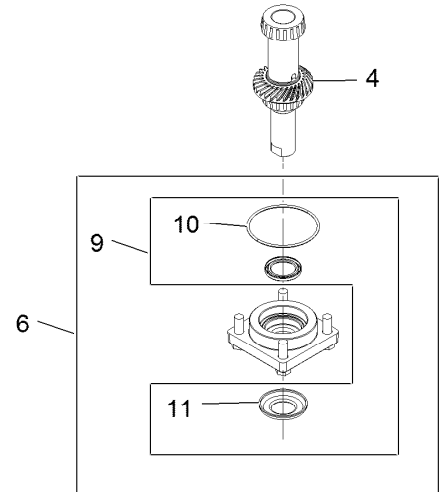

Gearbox Assembly No. 103-3460

Ref.	Part Number	Qty.	Description
1	109-0188	1	Asm, Input Pinion 42"
2	109-0190	1	Center Housing W/Plugs
3	109-0191	1	End Housing W/Plugs And Race
4	109-0192	1	Output Shaft, Gear And Brgs (42" LH)
5	109-0194	1	Output Shaft, Gear And Brgs (42" RH)
6	109-0196	1	Output Cap W/Race
7	109-0197	1	Asm, Connector Tube 42" Short
8	109-0199	1	Asm, Connector Tube 42" Long
9	109-0201	1	Kit, Output Seal
10	109-0203	1	O-Ring
11	109-0204	1	Washer, Cupped
12	109-0205	1	V-Ring ●
13	109-0202	1	Seal, Input ●
14	93-3987	28	Bolt - Blade

● Apply bead of Mobil HTS grease (P/N 103-5217 1.5 oz packet) (or a food-grade anti-seize) between input seal and v-ring.

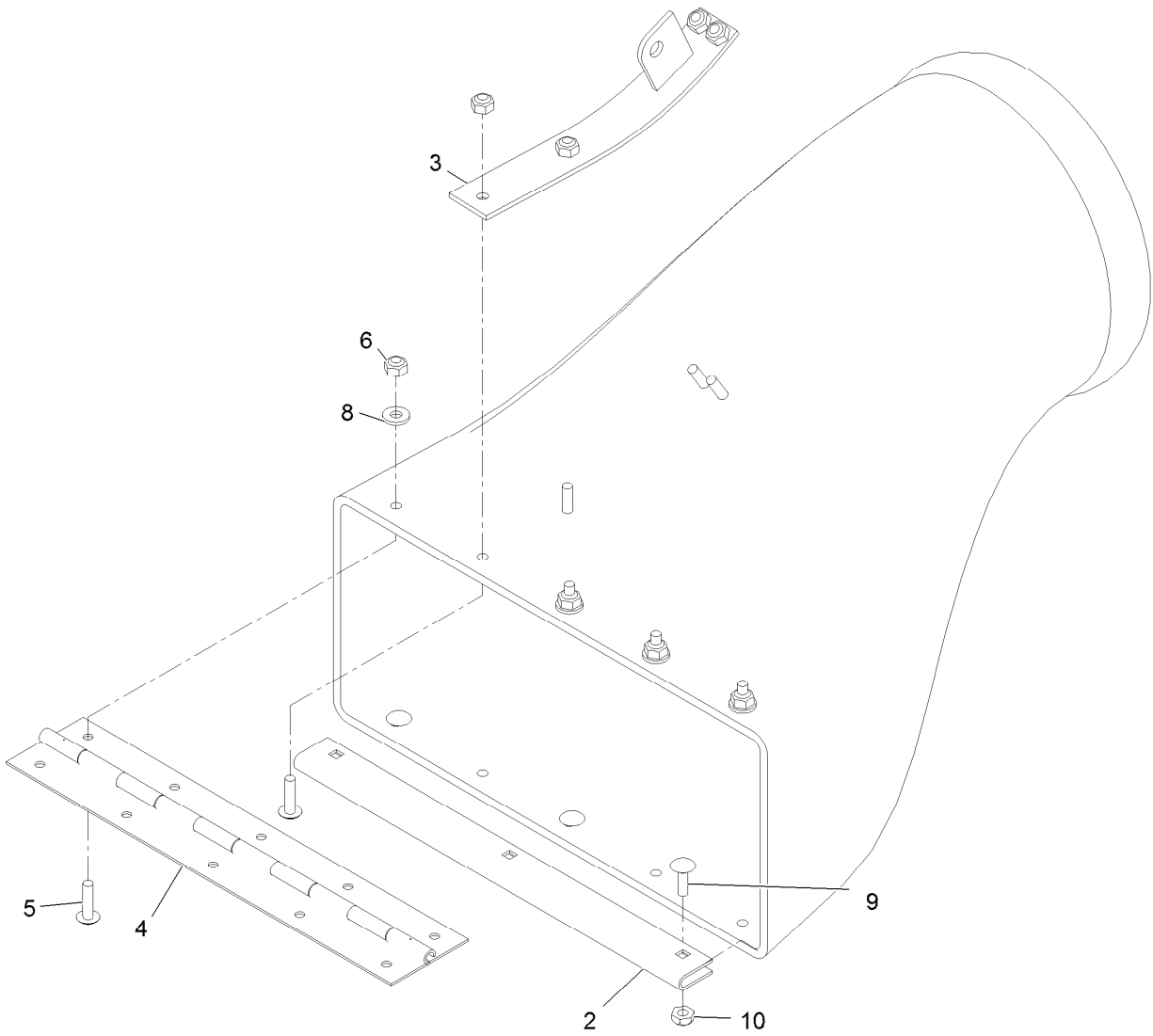

Discharge Tube Assembly No. 103-9487

<i>Ref.</i>	<i>Part Number</i>	<i>Qty.</i>	<i>Description</i>
2	109-2228-03	1	Guard, Plenum
3	103-5868-01	1	Wld, Spring Mount
4	103-4974	1	Hinge
5	1-803075	8	Screw-Truss Head #10-24 X 3/4
6	3296-2	8	Nut-Nyloc #10-24
8	3256-14	4	Washer-#10 Std
9	1-807533	3	Bolt-Carriage #10-24 X 5/8
10	3296-12	3	Nut-Nyloc #10-24 Thin

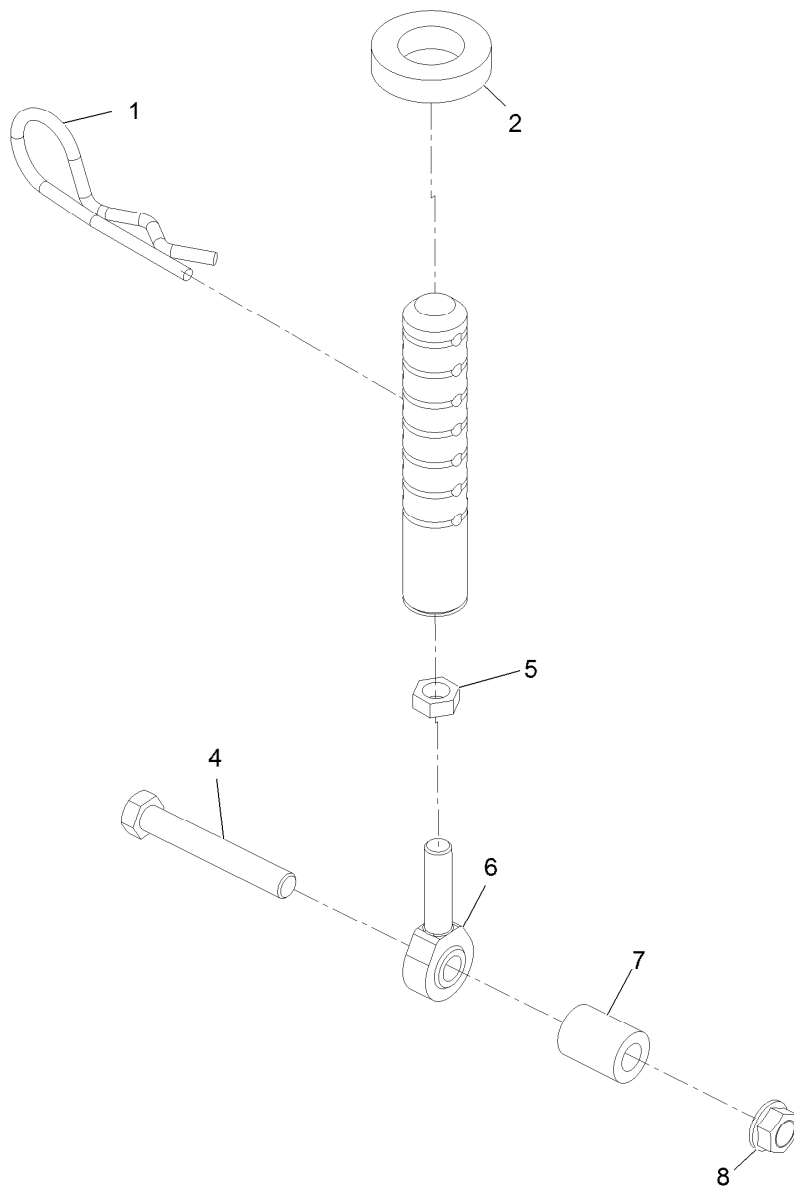

Rear Deck Height Adjustment Assembly No. 109-0322

<i>Ref.</i>	<i>Part Number</i>	<i>Qty.</i>	<i>Description</i>
1	103-7353	1	Pin, Cut Height
2	1-413425	1	Spacer
4	323-11	1	Screw-HH 3/8-16 X 2 1/4
5	3220-3	1	Nut-Jam 3/8-24
6	1-613204	1	Balljoint
7	106-5620	1	Tube-Interlock
8	3290-357	1	Nut-Whizlock 3/8-16

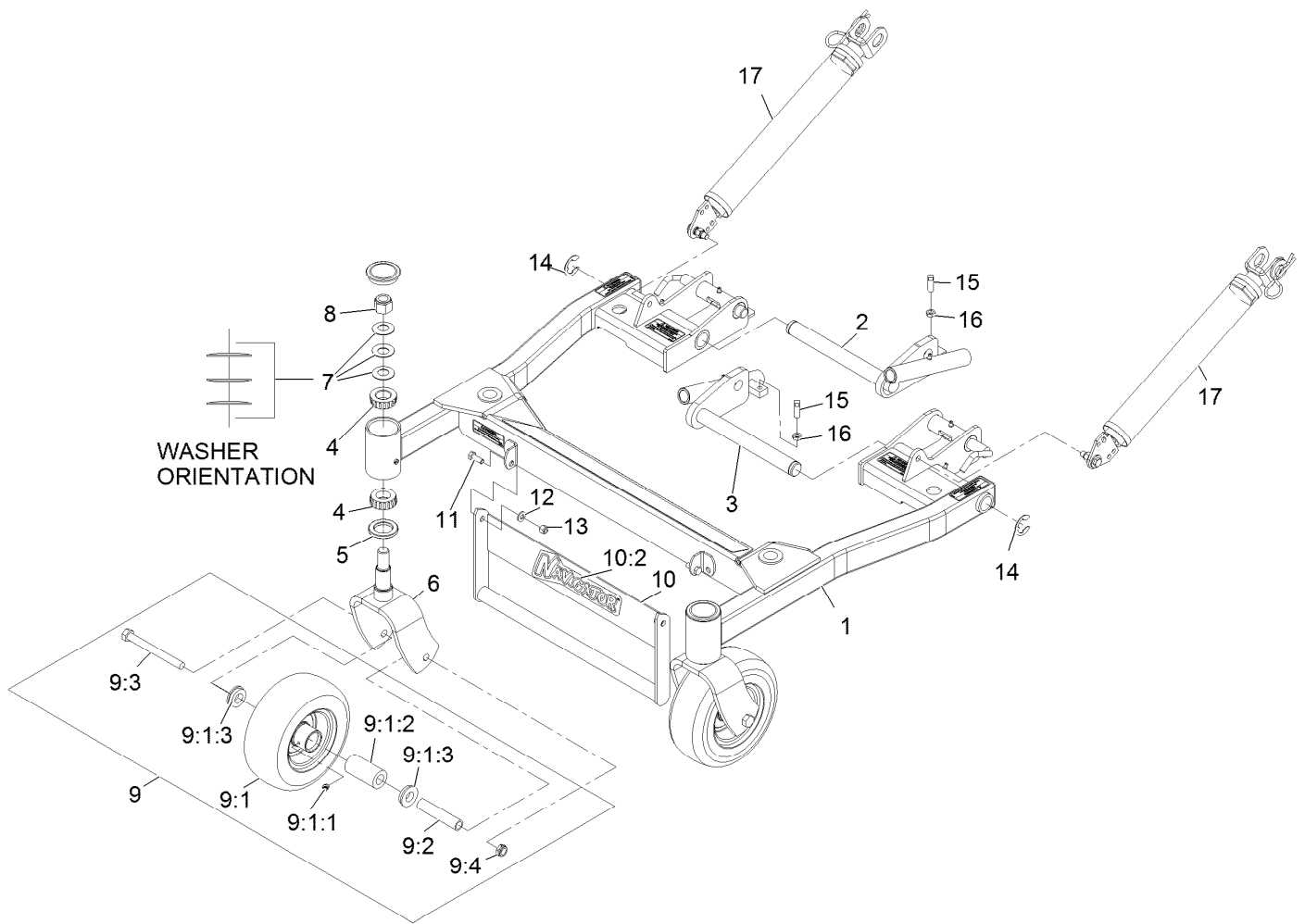

Deck Support Frame Assembly

Ref.	Part Number	Qty.	Description	Ref.	Part Number	Qty.	Description
1	103-9481	1	Asm, Front Frame W/Decals (42")	9:1:3	1-513810	2	Bushing-Flanged
2	103-3729-01	1	Wld, Deck Pivot (RH)	9:2	109-2094	1	Spacer, Front Caster
3	103-3732-01	1	Wld, Deck Pivot (LH)	9:3	325-19	1	Screw-HH 1/2-13 X 5
4	1-543509	4	Cone-Bearing Tapered Roller	9:4	3296-45	1	Nut-Nyloc 1/2-13 Thin
5	1-543511	2	Seal-Grease	10	103-9482	1	Asm, Deck Lift Handle W/Decal
6	109-1933-01	2	Wld, Fork And Spindle	10:2	103-8504	1	Decal, Navigator Model
7	1-633508	6	Washer-Spring Disc	11	322-4	2	Screw-HH 5/16-18 X 7/8
8	3296-51	2	Nut-Nyloc 3/4-10	12	1-303334	2	Washer-Spring Disc 5/16
9	103-9495	2	Asm, Caster Wheel W/Axle	13	3296-29	2	Nut-Nyloc 5/16-18
9:1	103-4324	1	Asm, Wheel And Tire 8X3.00-4 Sp	14	1-808519	2	Ring-Snap
9:1:1	302-61	1	Zerk-45° 1/4-28	15	3243-5	2	Setscrew-SQH 3/8-16 X 1
9:1:2	103-4588	1	Bearing, Roller Straight	16	3218-3	2	Nut-Jam 3/8-16
				17	116-7850	2	Lift Assist Spring ASM

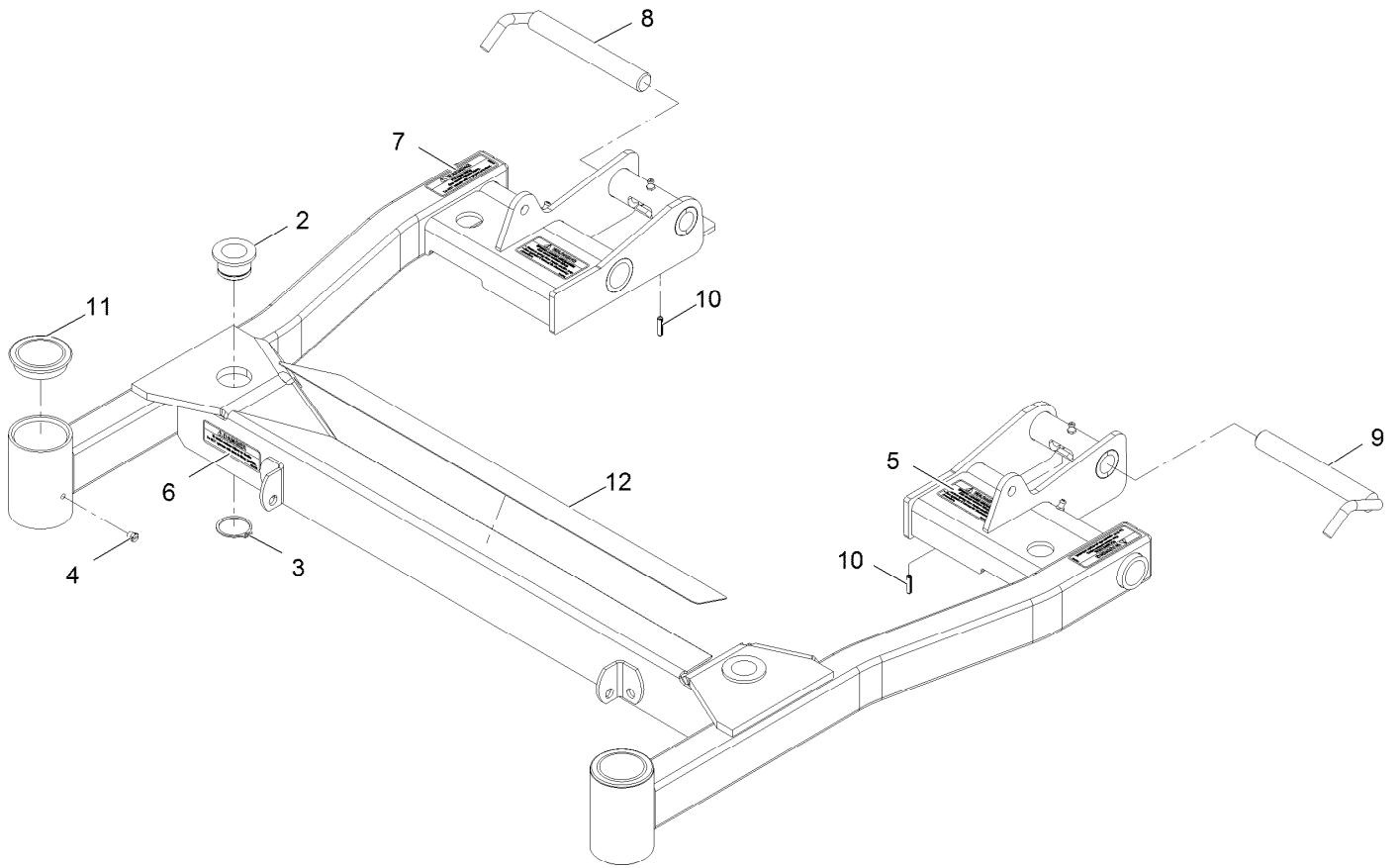

Deck Support W/Decals Assembly No. 103-9481

Ref.	Part Number	Qty.	Description
2	103-7436	2	Bushing, Deck Support
3	32120-33	2	Ring-Retaining
4	1-811010	2	Plug
5	103-8799	2	Decal, Spring
6	103-8798	1	Decal, Danger
7	103-8797	2	Decal, Folding Deck
8	103-4119	1	Wld, Deck Lock (RH)
9	103-4118	1	Wld, Deck Lock (LH)
10	32121-3	2	Rollpin 3/16 X 3/4
11	103-4882	2	Cap-Grease
12	103-8667	1	Pad, Anti Skid (42")

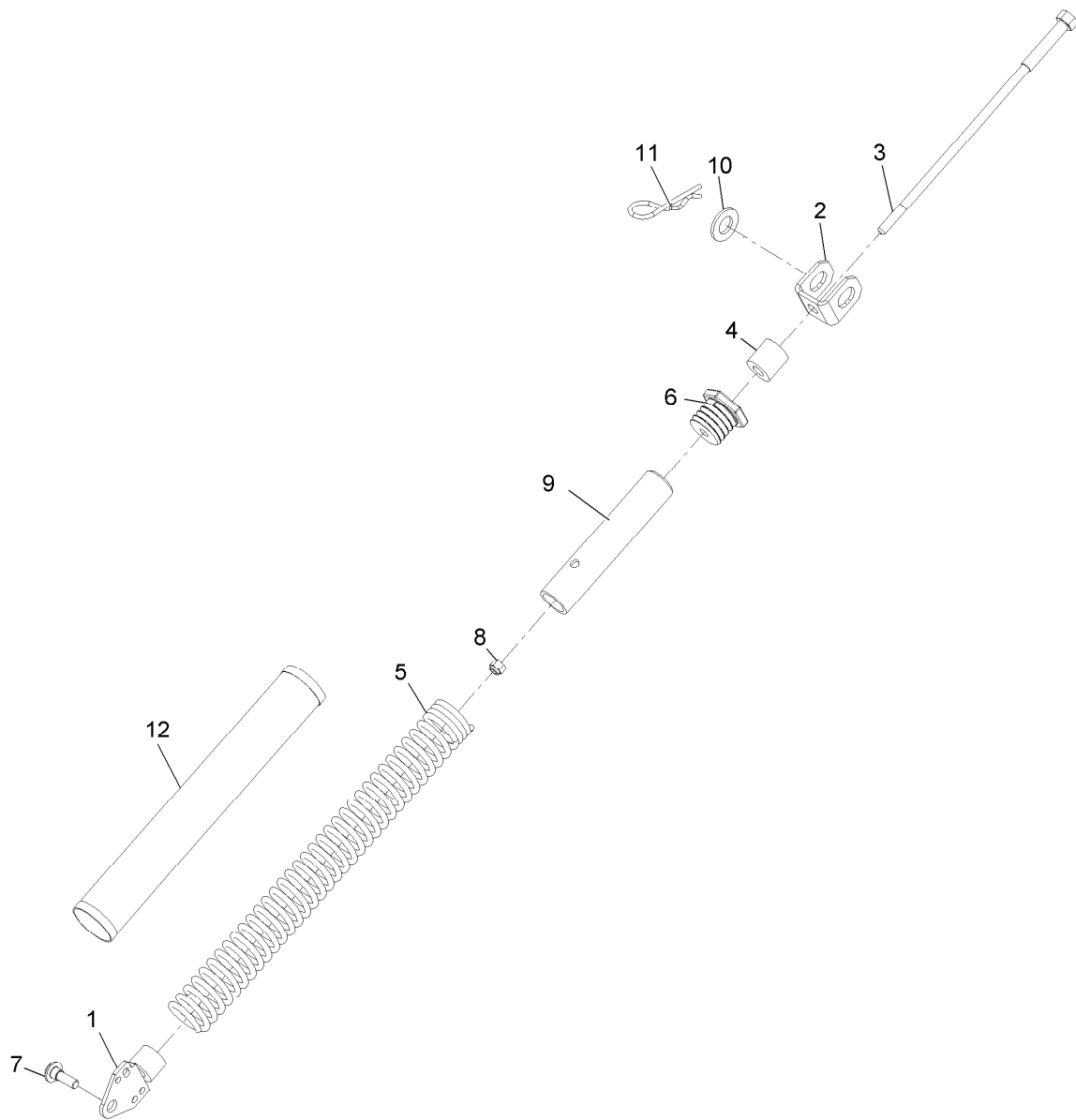

Spring Lift Assist Assembly No. 109-1979

Ref.	Part Number	Qty.	Description
1	103-4284	1	Wld, Spring Tensioner
2	103-4285	1	Mount, Deck Lift Spring
3	103-3773	1	Shaft, Spring Adjustment
4	109-1978	1	Spacer (42" Only)
5	103-4281	1	Spring, Extension
6	103-3772	1	Plug, Spring Adjuster
7	614672	1	Screw-Shoulder 3/8-16 X 1.295
8	3296-39	2	Nut-Nyloc 3/8-16
9	103-7865	1	Wld, Spring Tube
10	3256-28	1	Washer-3/4 Sae
11	103-7353	1	Pin, Cut Height
12	103-7971	1	Cover, Deck Spring

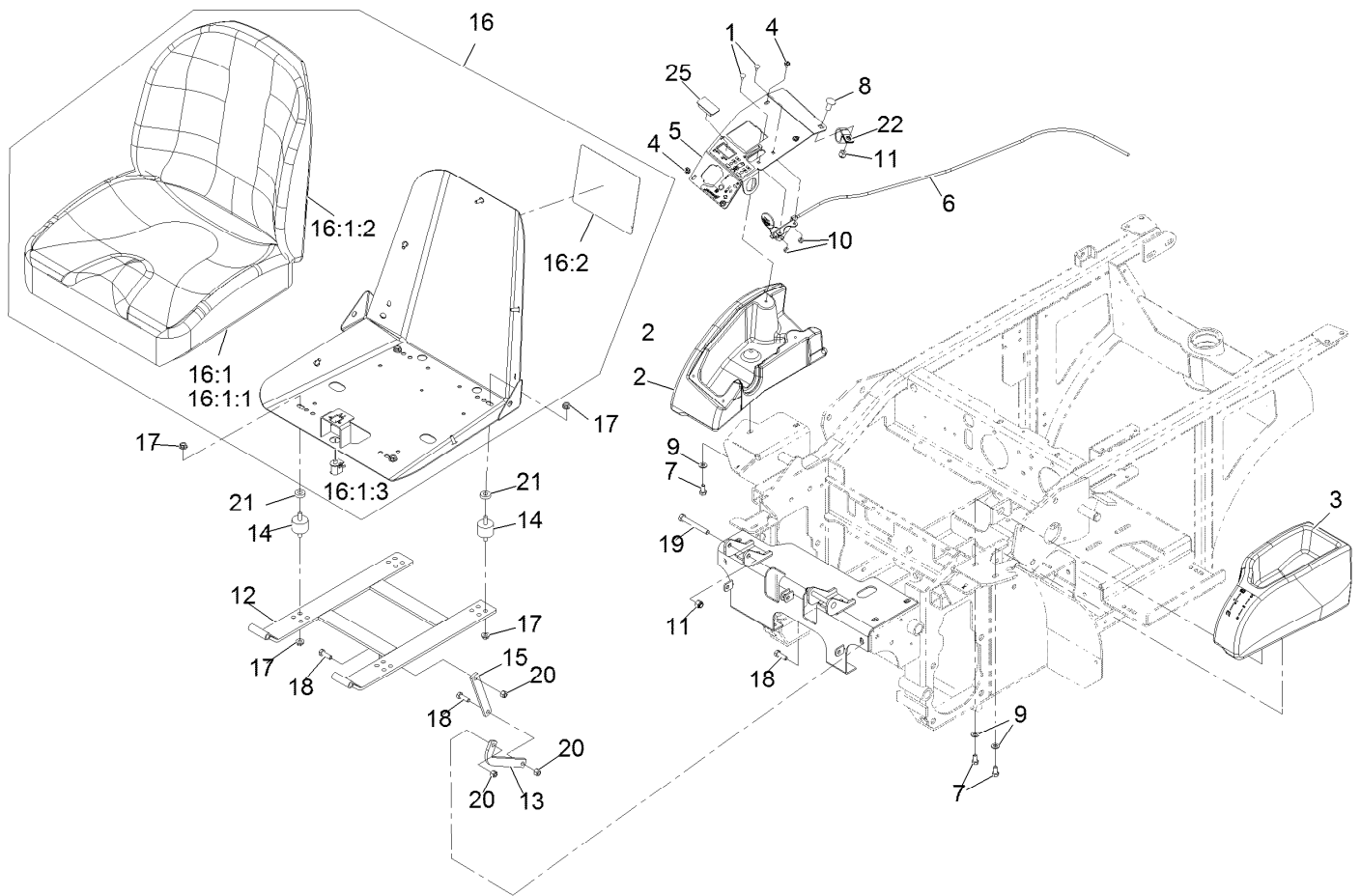

Seat and Consoles Assembly

Ref.	Part Number	Qty.	Description	Ref.	Part Number	Qty.	Description
1	1-807513	2	Bolt-Carriage #10-24 X 1/2	15	103-8563	1	Link, Seat
2	116-9430	1	Console, Navigator, RH	16	116-4849	1	ASM-Seat W/Decal
3	103-8146	1	Console, LH	16:1		1	ASM-Seat ●
4	109-2661	4	Screw-PPH #10-24 X 1/2	16:1:1	116-4848	1	ASM-Seat Bottom Cushion
5	116-9373	1	Control Panel W/Decals	16:1:2	116-3738	1	Cushion, Seat Back
6	109-4641	1	Cable, Control Throttle	16:1:3	82-2190	1	Switch
7	322-2	6	Screw-HH 5/16-18 X 5/8	16:2	116-1175	1	Decal, Service Aid Nav
8	3231-27	1	Bolt-Carriage 3/8-16 X 7/8	17	32128-20	8	Nut-Whizlock 5/16-18
9	3256-23	6	Washer-5/16 Sae	18	322-5	3	Screw-HH 5/16-18 X 1
10	3296-2	2	Nut-Nyloc #10-24	19	323-14	2	Screw-HH 3/8-16 X 3
11	3296-39	3	Nut-Nyloc 3/8-16	20	3296-29	3	Nut-Nyloc 5/16-18
12	103-4362-03	1	Wld, Seat Frame Std	21	5-0652	4	Spacer
13	116-9554	1	Link-Seat Stop	22	1-643312	1	Clip-Loom
14	103-5496	4	Mount, Vibration Rubber	25	99-7420	1	Plug-Hole

● Not serviced separately

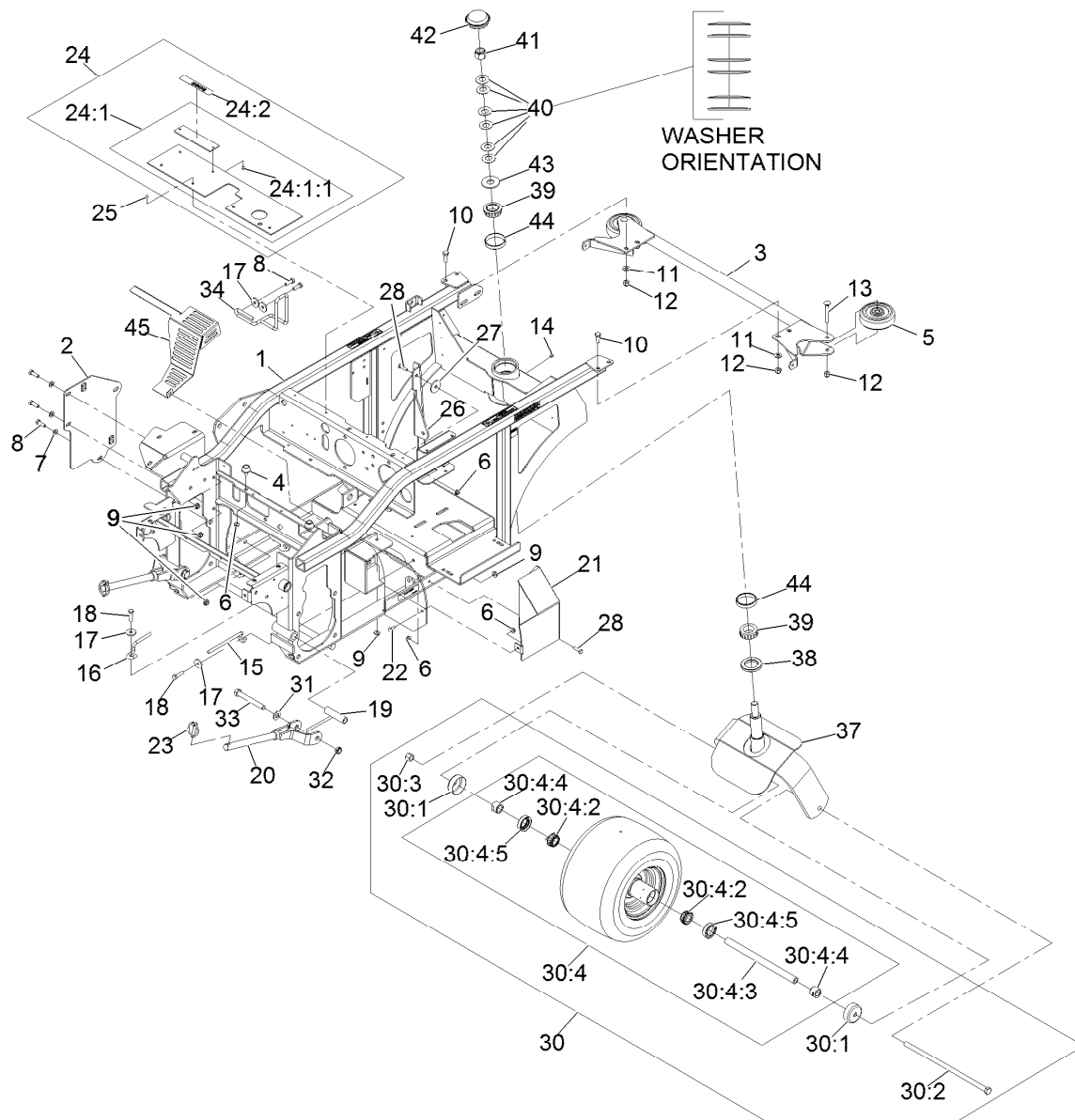

Main Frame Assembly

Ref.	Part Number	Qty.	Description	Ref.	Part Number	Qty.	Description
1	116-7482	1	Frame ASM W/Decals	20	103-6596-03	2	Wld, Push Rod
2	116-7396-03	1	Support Plate ASM	21	103-9475	1	Asm Drive, Shield
3	109-0925-03	1	Wld, Bumper Rear	22	321-3	1	Screw-HH 1/4-20 X 5/8
4	109-2365	1	Bumper-Rubber	23	103-4155	2	Pin-Lynch
5	103-5408	2	Wheel	24	103-9476	1	Asm, Shield W/Decal
6	32128-33	5	Nut-Whizlock 1/4-20	24:1		1	ASM,Shield Lift ●
7	3256-23	3	Washer-5/16 Sae	24:1:1	1-803035	2	Rivet 3/16 X 1/4
8	322-5	5	Screw-HH 5/16-18 X 1	24:2	98-4361	1	Decal-Warning
9	32128-20	5	Nut-Whizlock 5/16-18	25	1-803035	4	Rivet 3/16 X 1/4
10	323-6	4	Screw-HH 3/8-16 X 1	26	109-5874-03	1	Brace, PTO
11	3256-24	4	Washer-3/8 Sae	27	1-213069	1	Washer
12	3296-39	6	Nut-Nyloc 3/8-16	28	321-6	2	Screw-HH 1/4-20 X 1
13	3231-31	2	Bolt-Carriage 3/8-16 X 2 1/2	30	103-9494	1	Asm, Rear Caster Wheel W/Axle
14	1-811010	1	Plug	30:1	103-2768	2	Guard-Seal
15	103-8333	1	Guide, Belt	30:2	103-7738	1	Screw-HH 1/2-13 X 13
16	103-8349	1	Guide, Belt	30:3	3296-23	1	Nut-Nyloc 1/2-13
17	1-613235	4	Washer	30:4	103-5305	1	Asm, Wheel Tire And Brg 13X8.00-6 Sp
18	322-6	2	Screw-HH 5/16-18 X 1 1/4				
19	1-633060	2	Spacer-Wheel, Short				

● Not serviced separately

■ Use Pro-Lock, Nut Type (P/N 1-840022, .5ml tube) on threads.

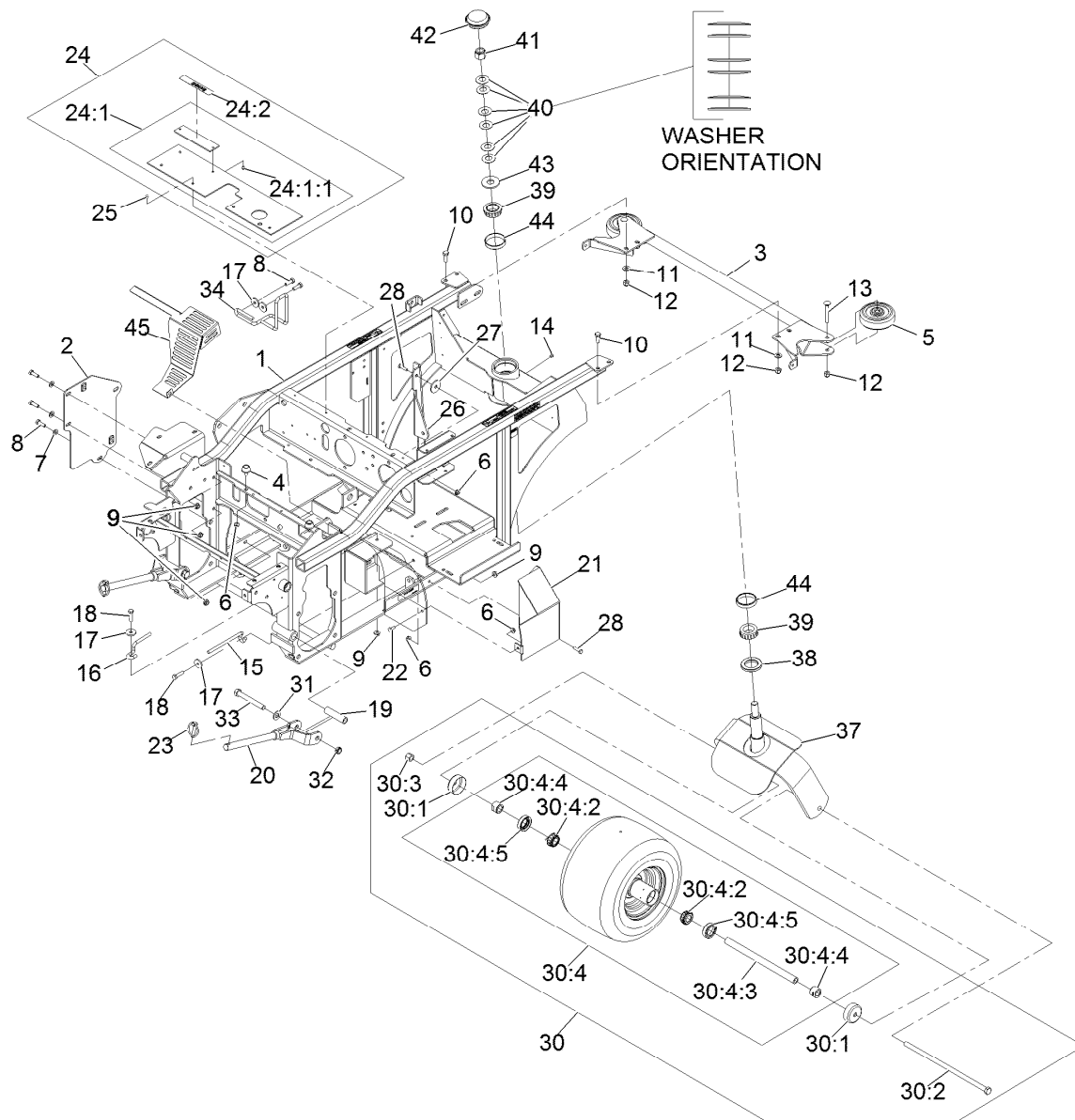

Main Frame Assembly (continued)

Ref.	Part Number	Qty.	Description	Ref.	Part Number	Qty.	Description
30:4:2	1-633585	2	Bearing-Cone Tapered Roller	37	103-3351-03	1	Wld, Rear Caster Fork
30:4:3	103-5302	1	Axle, Caster	38	103-9027	1	Seal, Grease
30:4:4	103-3051	2	Spacer-Nut ■	39	103-9028	2	Cone-Bearing Taper Roller
30:4:5	103-0063	2	Seal-Double Lip	40	1-633508	6	Washer-Spring Disc
31	3256-26	2	Washer-1/2 Sae	41	3296-51	1	Nut-Nyloc 3/4-10
32	3296-45	2	Nut-Nyloc 1/2-13 Thin	42	103-9057	1	Cap, Grease
33	325-17	2	Screw-HH 1/2-13 X 4	43	3256-8	1	Washer
34	116-8323	1	Guide-Belt	44	103-9029	2	Cup-Bearing Tapered Roller
				45	116-7272-03	1	Shield-Heat

● Not serviced separately

■ Use Pro-Lock, Nut Type (P/N 1-840022, .5ml tube) on threads.

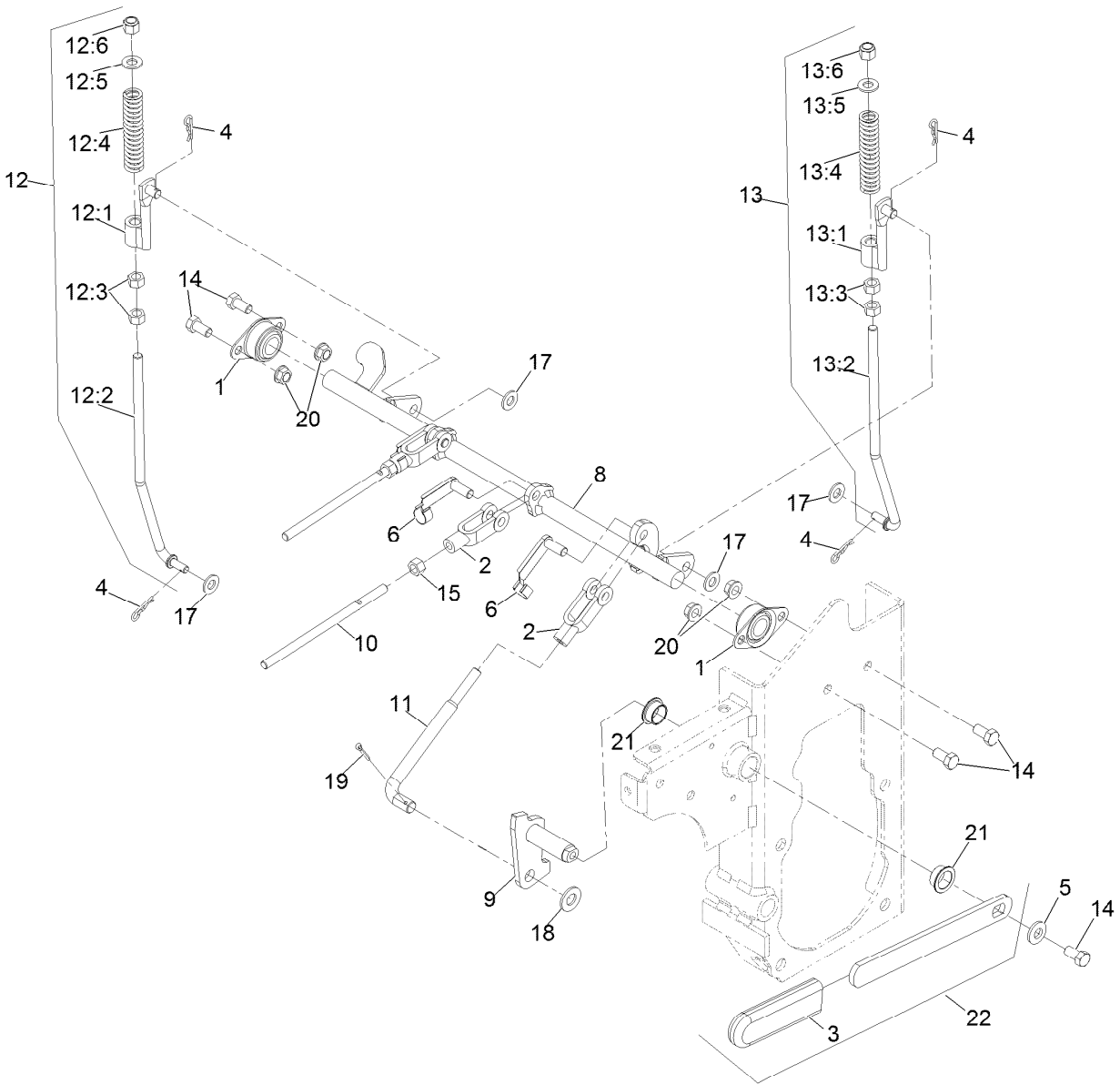

Park Brake Assembly

Ref.	Part Number	Qty.	Description	Ref.	Part Number	Qty.	Description
1	1-633102	2	Bearing-Flanged	13	116-9749	1	LH Brake Linkage ASM
2	1-633131	3	Yoke-Linkage, Brake	13:1	116-8467	1	Brake Linkage ASM
3	1-633268	1	Grip-Lever	13:2	116-8464	1	Link-Brake, LH
4	1-806003	4	Hairpin-Cotter	13:3	3219-3	2	Nut-Hex 3/8-24
5	98-5975	1	Washer-Spring Disc 3/8	13:4	116-8470	1	Spring-Compression
6	103-2399	3	Pin-Clevis Spring 3/8	13:5	3256-24	1	Washer-3/8 Sae
8	116-7483-03	1	Brakeshaft ASM [black]	13:6	3296-6	1	Nut-Nyloc 3/8-24
9	116-7486	1	Brake Pivot ASM	14	323-4	5	Screw-HH 3/8-16 X 3/4
10	116-7838	2	Rod-Linkage Brake	15	3219-3	2	Nut-Hex 3/8-24
11	116-8474	1	Rod-Linkage, Brake	17	3256-24	4	Washer-3/8 Sae
12	116-9748	1	RH Brake Linkage ASM	18	3256-26	1	Washer-1/2 Sae
12:1	116-8467	1	Brake Linkage ASM	19	3272-10	1	Pin-Cotter 1/8 X 3/4
12:2	116-8465	1	Link-Brake, RH	20	3290-357	4	Nut-Whizlock 3/8-16
12:3	3219-3	2	Nut-Hex 3/8-24	21	108519	2	Bushing-Bronze
12:4	116-8470	1	Spring-Compression	22	103-9469	1	Asm, Park Brake Handle W/Grip
12:5	3256-24	1	Washer-3/8 Sae				
12:6	3296-6	1	Nut-Nyloc 3/8-24				

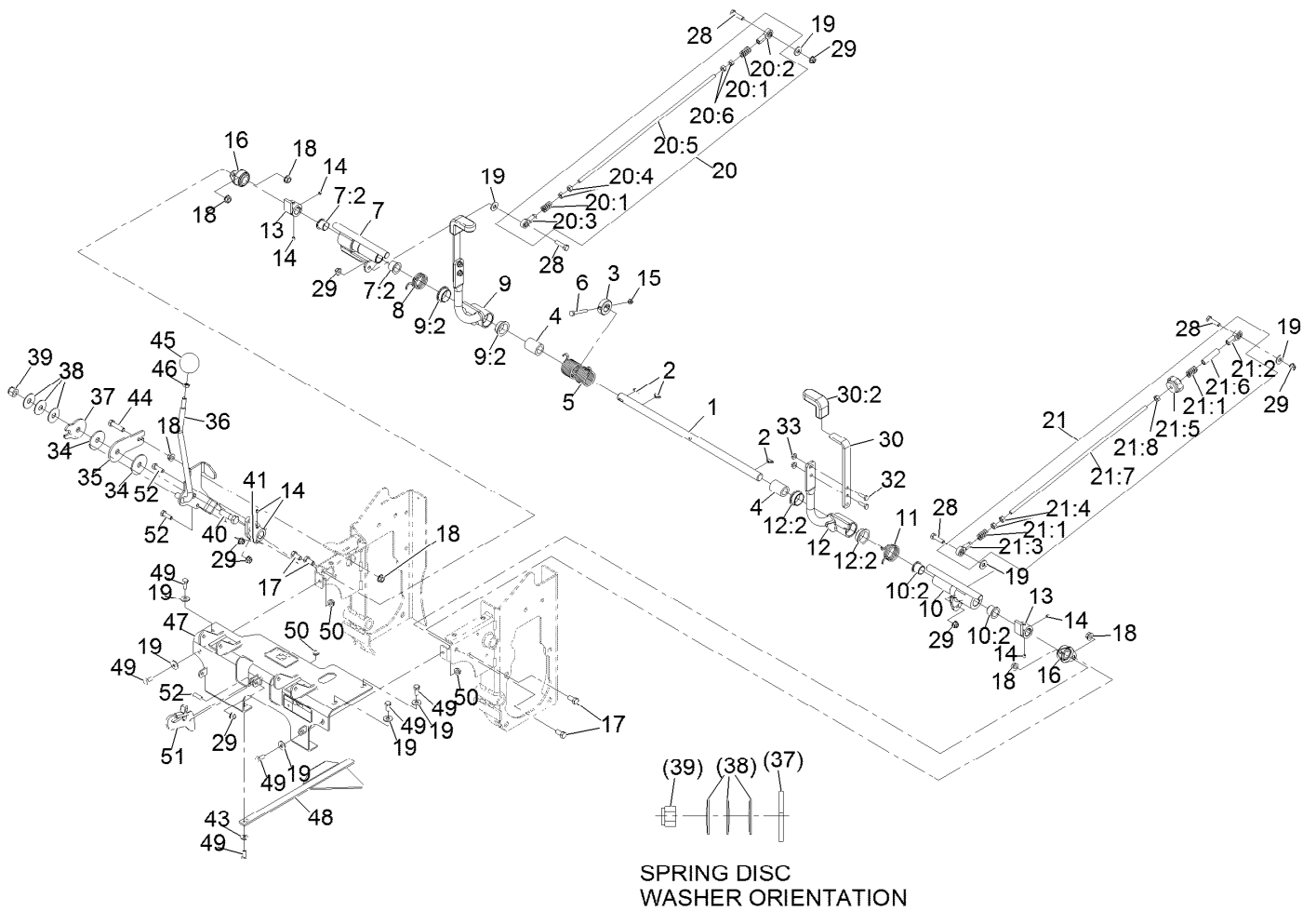

Speed Control Assembly

Ref.	Part Number	Qty.	Description	Ref.	Part Number	Qty.	Description
1	116-7856	1	Shaft-Speed Control	16	1-633102	2	Bearing-Flanged
2	3257-5	3	Key-Woodruff #9 3/4 X 3/16	17	323-4	4	Screw-HH 3/8-16 X 3/4
3	116-7372	1	Hub-Center Stop	18	3290-357	6	Nut-Whizlock 3/8-16
4	116-7414	2	Bushing-Plastic	19	3256-3	9	Washer-5/16 Std
5	116-8475	1	Spring-Double Torsion	20	116-9667	1	RH Pump Linkage ASM
6	321-11	1	Screw-HH 1/4-20 X 2	20:1	1-323245	2	Spring-Compression
7	116-8444	1	RH Control Hub ASM	20:2	1-543017	1	Balljoint-RH
7:2	103-4398	2	Bearing, Flange Iglide	20:3	1-633152	1	Balljoint-LH
8	116-7380	1	Spring-Torsion, RH	20:4	1-804524	2	Nut
9	116-7408	1	RH Steering Handle ASM W/Bearings	20:5	116-7492	1	Rod-Steering Linkage
9:2	116-7422	2	Bearing-Flange Iglide	20:6	3219-2	2	Nut-Hex
10	116-7416	1	LH Control Hub ASM	21	116-9668	1	LH Pump Linkage ASM
10:2	103-4398	2	Bearing, Flange Iglide	21:1	1-323245	2	Spring-Compression
11	116-7381	1	Spring-Torsion, LH	21:2	1-543017	1	Balljoint-RH
12	116-7421	1	LH Steering Handle ASM W/Bearings	21:3	1-633152	1	Balljoint-LH
12:2	116-7422	2	Bearing-Flange Iglide	21:4	1-804524	2	Nut
13	103-4342	2	Wld,Hub Speed Control	21:5	103-3060	1	Knob-Tracking
14	108-0989	6	Setscrew-1/4-20 X 1/4	21:6	103-5945	1	Spacer
15	3296-56	1	Nut-Nyloc 1/4-20 Thin	21:7	116-7492	1	Rod-Steering Linkage
				21:8	3219-2	1	Nut-Hex
				28	322-6	4	Screw-HH 5/16-18 X 1 1/4

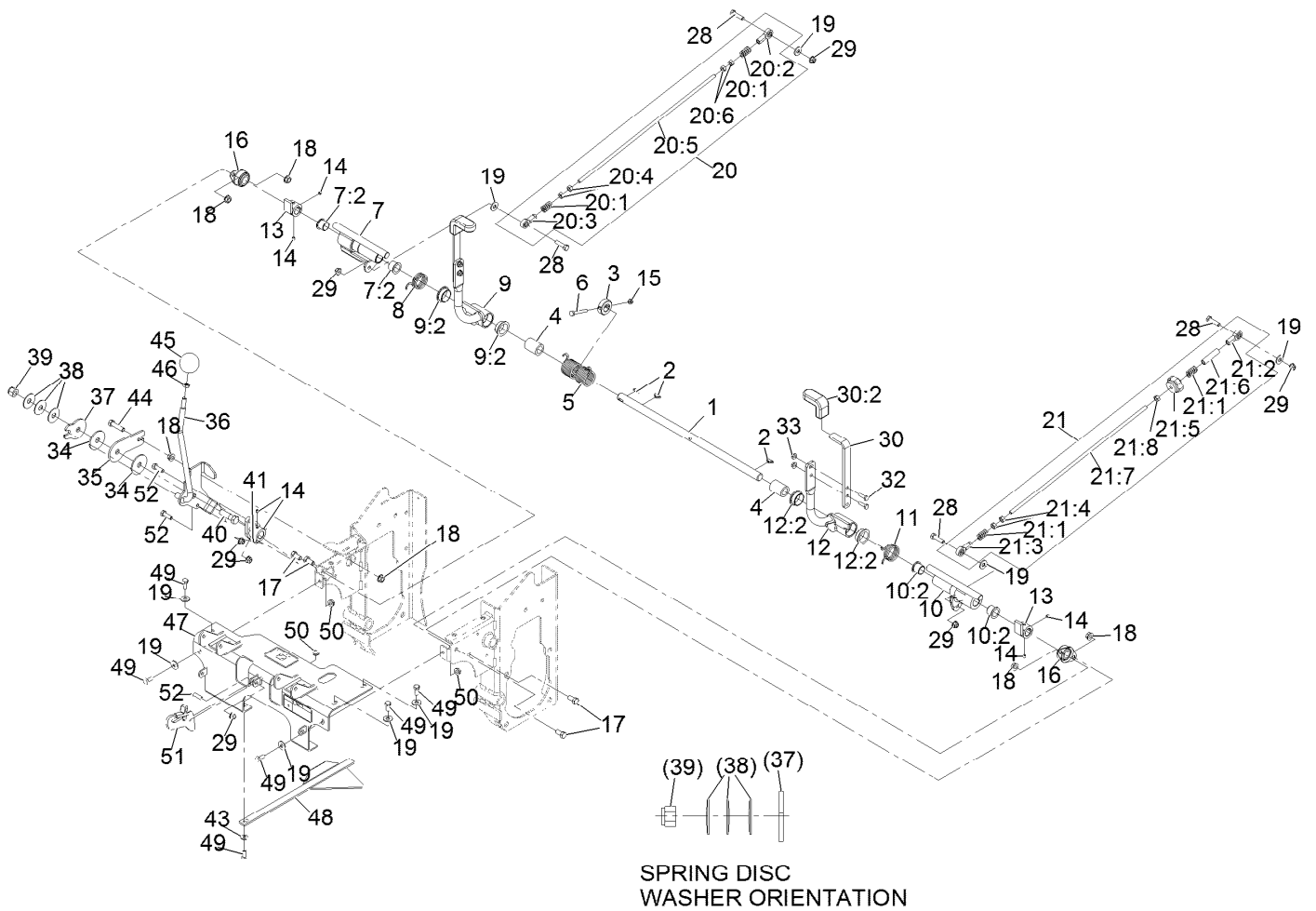

Speed Control Assembly (continued)

Ref.	Part Number	Qty.	Description	Ref.	Part Number	Qty.	Description
29	104-8300	7	Nut-Nyloc 5/16-18 Flg	41	116-7859	1	Speed Control Hub ASM
30	116-9246	2	Handle W/Grip ASM	43	3256-23	1	Washer-5/16 Sae
30:2	103-5994	1	Grip, Steering Handle	44	323-8	1	Screw-HH 3/8-16 X 1 1/2
32	321-5	4	Screw-HH 1/4-20 X 7/8	45	103-4397	1	Knob, Speed Control
33	32128-33	4	Nut-Whizlock 1/4-20	46	3218-3	1	Nut-Jam 3/8-16
34	103-5009	2	Disc, Friction	47	116-7384	1	Console ASM W/Decals
35	116-7846	1	Plate-Speed Control Friction	48	103-5993-03	1	Guide, Plenum
36	116-7845	1	Speed Control Lever ASM	49	322-3	6	Screw-HH 5/16-18 X 3/4
37	116-7849	1	Plate-Speed Control Friction	50	32128-20	3	Nut-Whizlock 5/16-18
38	103-5018	3	Washer-Spring Disc	51	103-8494	1	Hook
39	3296-19	1	Nut-Nyloc 1/2-20	52	322-5	3	Screw-HH 5/16-18 X 1
40	116-7848	1	Screw-HH				

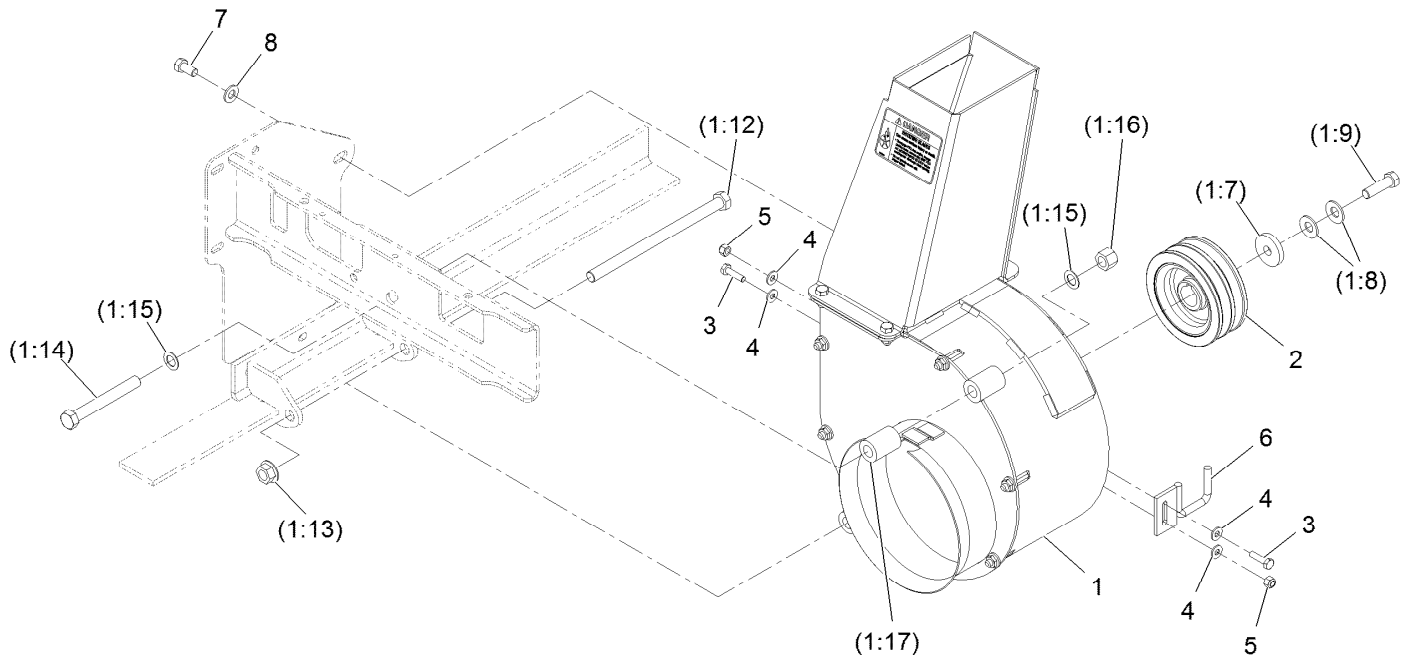

Blower Assembly

Ref.	Part Number	Qty.	Description
1	116-9649	1	Blower Complete ASM
2	103-6733	1	Sheave, Blower
3	321-6	2	Screw-HH 1/4-20 X 1
4	3256-22	4	Washer-1/4 Sae
5	3296-42	2	Nut-Nyloc 1/4-20
6	103-9167-03	1	Wld, Guide
7	323-4	1	Screw-HH 3/8-16 X 3/4
8	3256-24	1	Washer-3/8 Sae

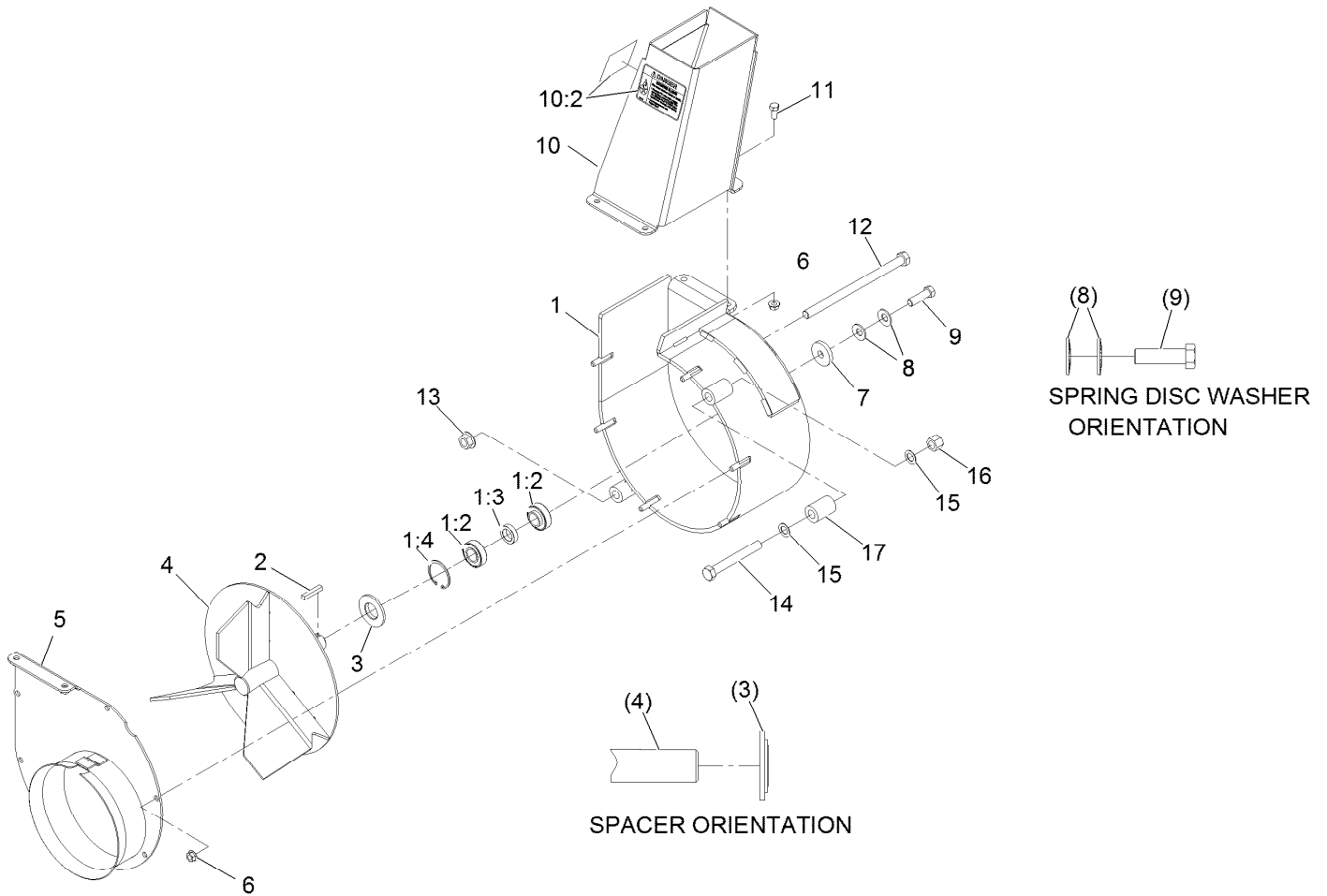

Complete Blower Assembly No. 116-9649

Ref.	Part Number	Qty.	Description	Ref.	Part Number	Qty.	Description
1	116-9648	1	Housing W/Bearings ASM	8	1-603610	2	Washer-Spring Disc 7/16
1:2	103-3540	2	Bearing, Ball	9	3212-6	1	Screw-HH 7/16-20 X 1 1/2
1:3	103-4921	1	Spacer, Bearing	10	103-9474	1	Asm, Discharge Chute W/Decal
1:4	32120-8	2	Ring-Snap	10:2	109-7318	2	Decal, Danger
2	67-7490	1	Key-Machine 1/4 X 1/4 X 1 1/2	11	322-3	4	Screw-HH 5/16-18 X 3/4
3	103-3894	1	Spacer, Blower	12	325-42	1	Screw-HH 1/2-13 X 8
4	103-5194	1	Wld, Impeller	13	32128-23	1	Nut-Hex 1/2-13 Side Lock
5	103-3370-03	1	Wld, Blower Cover Assembly	14	325-17	1	Screw-HH 1/2-13 X 4
6	32128-20	10	Nut-Whizlock 5/16-18	15	18-9810	2	Washer-Thrust
7	1-543610	1	Washer	16	3296-23	1	Nut-Nyloc 1/2-13
				17	103-6999	1	Spacer, Mount

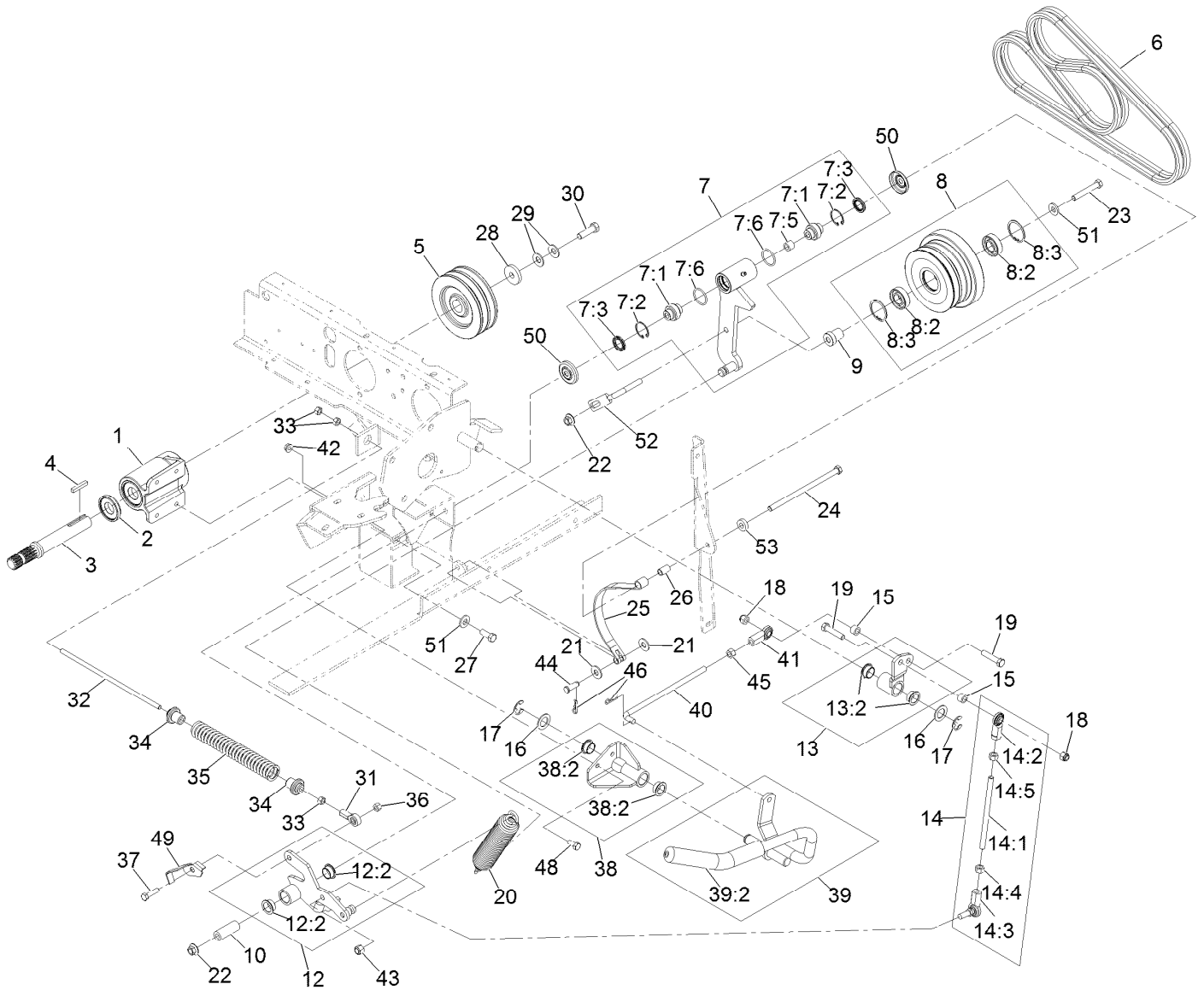

Jackshaft Assembly

Ref.	Part Number	Qty.	Description	Ref.	Part Number	Qty.	Description
1	103-2544	1	Jackshaft ASM	13:2	108519	2	Bushing-Bronze
2	103-2535	1	Spacer-Guard Bottom	14	103-7392	1	Asm, Link Clutching
3	103-6735	1	Jackshaft	14:1	103-7393	1	Linkage, Rod
4	67-7490	1	Key-Machine 1/4 X 1/4 X 1 1/2	14:2	103-1167	1	Joint-Ball End, LH
5	103-6732	1	Sheave	14:3	103-7994	1	Balljoint
6	103-6737	1	Belt, Matched Pair	14:4	3219-3	1	Nut-Hex 3/8-24
7	103-8253	1	Asm, Idler Pivot	14:5	3219-20	1	Nut-Hex, LH
7:1	103-3504	2	Bearing-Spherical	15	92-9025	2	Spacer
7:2	32120-10	2	Ring-Snap	16	1-303007	2	Washer
7:3	103-3506	2	Seal-Single Lip	17	32151-48	2	E-Ring
7:5	1-413088	1	Bushing-Lever, Lift	18	3296-39	2	Nut-Nyloc 3/8-16
7:6	106-7159	2	O-Ring	19	323-9	2	Screw-HH 3/8-16 X 1 3/4
8	103-9439	1	Asm, Idler Sheave	20	109-0148	1	Spring-Extension
8:2	251-347	2	Bearing-Ball	21	3256-4	2	Washer-3/8 Std
8:3	32151-13	2	Ring-Retaining	22	32128-19	2	Nut-Hex 3/8-16 Side Lock
9	103-7350	1	Spacer, Idler	23	323-12	1	Screw-HH 3/8-16 X 2 1/2
10	103-7382	1	Bushing	24	323-36	1	Screw-HH 3/8-16 X 7
12	103-9296	1	Asm, Arm W/Bushing	25	103-7697	1	Band, Brake
12:2	108519	2	Bushing-Bronze	26	103-9816	1	Spacer
13	103-9297	1	Asm, Arm W/Bushing	27	323-6	4	Screw-HH 3/8-16 X 1
				28	1-543610	1	Washer

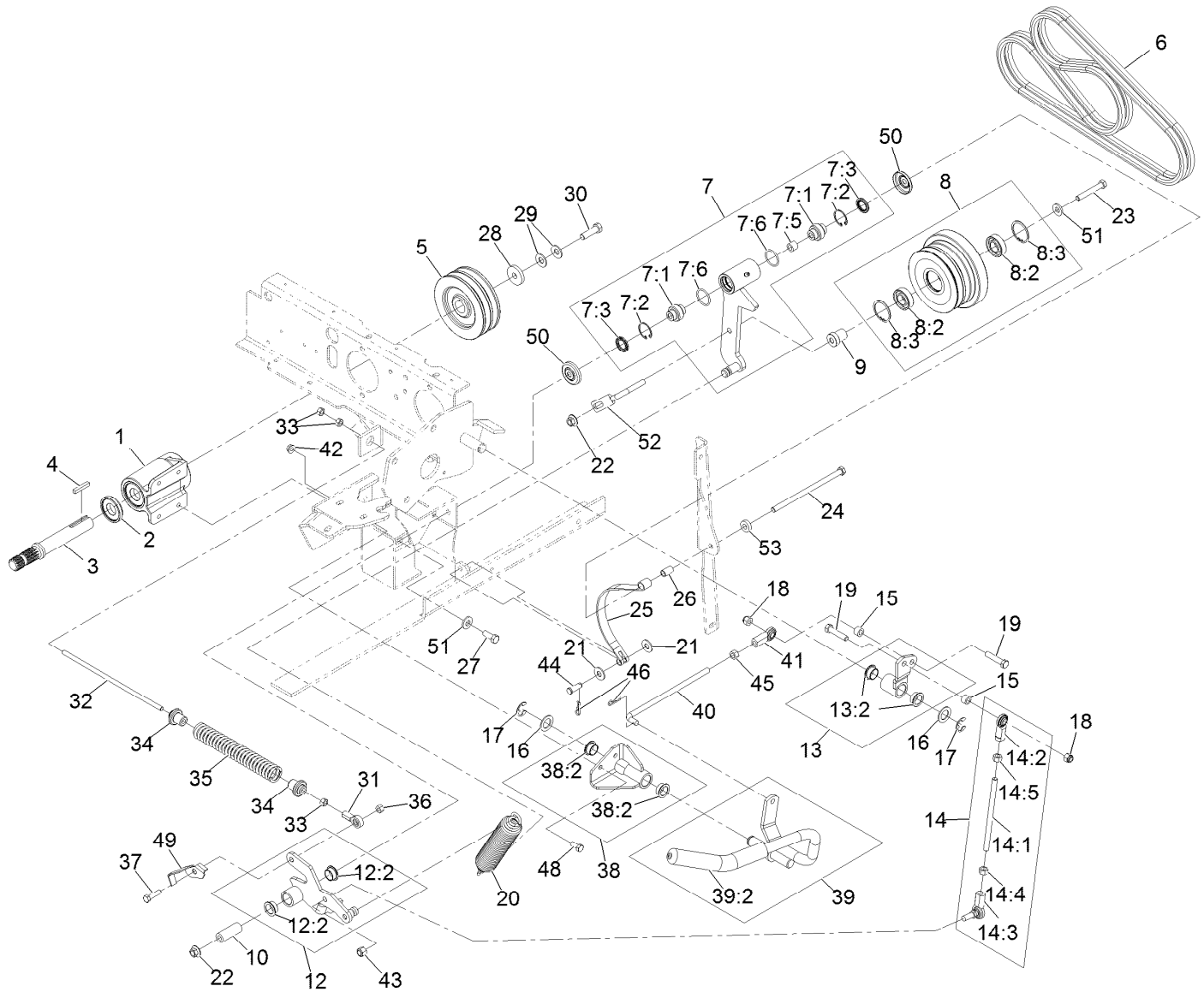

Jackshaft Assembly (continued)

Ref.	Part Number	Qty.	Description	Ref.	Part Number	Qty.	Description
29	1-603610	2	Washer-Spring Disc 7/16	40	103-8277	1	Link, Handle
30	3212-6	1	Screw-HH 7/16-20 X 1 1/2	41	103-0608	1	Balljoint
31	1-543017	1	Balljoint	42	32128-20	2	Nut-Whizlock 5/16-18
32	103-7996	1	Linkage, PTO Brake Rod	43	3296-6	1	Nut-Nyloc 3/8-24
33	3219-2	3	Nut-Hex 5/16-24	44	283-2	1	Pin-Clevis 3/8 X 1 1/6
34	103-8254	2	Bushing, Spring	45	3219-3	1	Nut-Hex 3/8-24
35	103-7997	1	Spring, Brake	46	1-806003	2	Hairpin-Cotter
36	3296-29	1	Nut-Nyloc 5/16-18	48	322-3	2	Screw-HH 5/16-18 X 3/4
37	322-6	1	Screw-HH 5/16-18 X 1 1/4	49	103-8716-03	1	Flag, Switch
38	103-9295	1	Asm, Pivot W/Bushing	50	103-2916	2	Guard-Top
38:2	108519	2	Bushing-Bronze	51	98-5975	5	Washer-Spring Disc 3/8
39	103-9486	1	Asm, PTO Handle W/Grip	52	109-5491	1	Belt, Guide
39:2	103-8153	1	Grip-Lever, Control	53	5-0652	1	Spacer

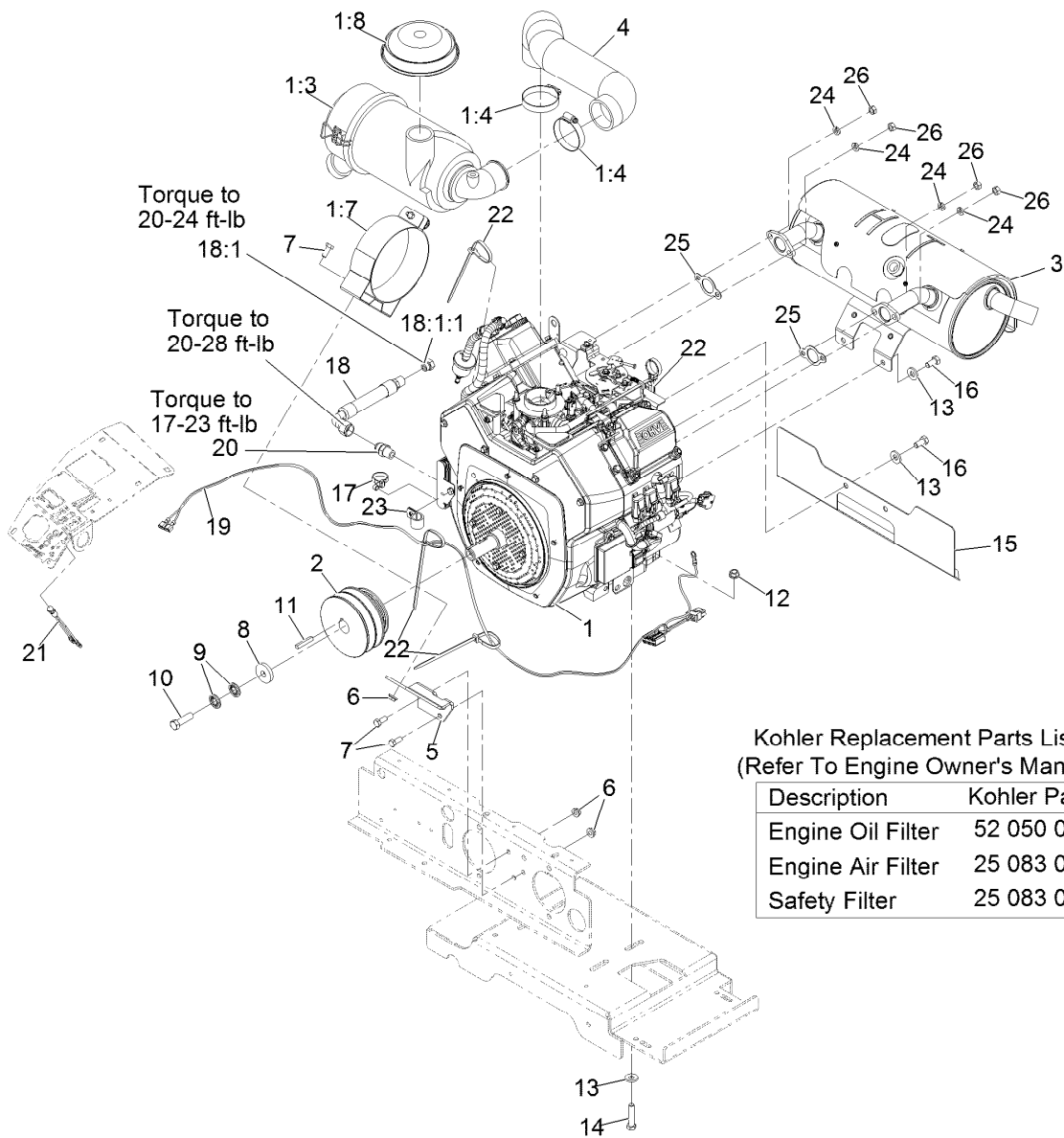

Kohler Replacement Parts List
(Refer To Engine Owner's Manual)

Description	Kohler Part
Engine Oil Filter	52 050 02
Engine Air Filter	25 083 01
Safety Filter	25 083 04

Engine Assembly

Ref.	Part Number	Qty.	Description	Ref.	Part Number	Qty.	Description
1		1	ASM-Engine 730Kc Efi ●	13	98-5975	8	Washer-Spring Disc 3/8
1:3	103-8569	1	Air Cleaner, Canister Nav	14	323-9	4	Screw-HH 3/8-16 X 1 3/4
1:4	2412-42	2	Clamp-Hose	15	109-0181-03	1	Shield, Exhaust
1:7	103-1058	1	Bracket-Filter, Air	16	323-4	4	Screw-HH 3/8-16 X 3/4
1:8	100-2436	1	Hood	17	109-7896	1	Tie-Cable
2	103-6731	1	Sheave, Engine	18	116-5338	1	ASM-Oil Drain Hose W/Plug
3	116-3961	1	Muffler	18:1	353-508	1	Plug-W/O-Ring
4	116-4016	1	Hose-Air Intake	18:1:1	237-42	1	O-Ring
5	103-3695-03	1	Bracket, Air Filter	19	116-4543	1	Harness-Light Indicator (Efi)
6	32128-20	4	Nut-Whizlock 5/16-18	20	116-1455	1	Fitting-,Straight ■
7	322-3	4	Screw-HH 5/16-18 X 3/4	21	1-643267	1	Indicator-Red Led
8	1-543610	1	Washer	22	1-303335	4	Tie-Cable 7 15/16 (Large)
9	1-603610	2	Washer-Spring Disc 7/16	23	1-633396	1	Clip-Loom 5/8
10	3212-6	1	Screw-HH 7/16-20 X 1 1/2 ▲	24	1-805005	4	Washer-Lock
11	67-7490	1	Key-Machine 1/4 X 1/4 X 1 1/2	25	1-653291	2	Gasket-Exhaust
12	3290-357	4	Nut-Whizlock 3/8-16	26	33014-00	4	Nut-Hex

- Not serviced separately
- Use a Teflon Pipe Sealant or equivalent on threads.
- ▲ Use Pro-Lock, Nut Type (P/N 1-840022, .5ml tube) on threads.

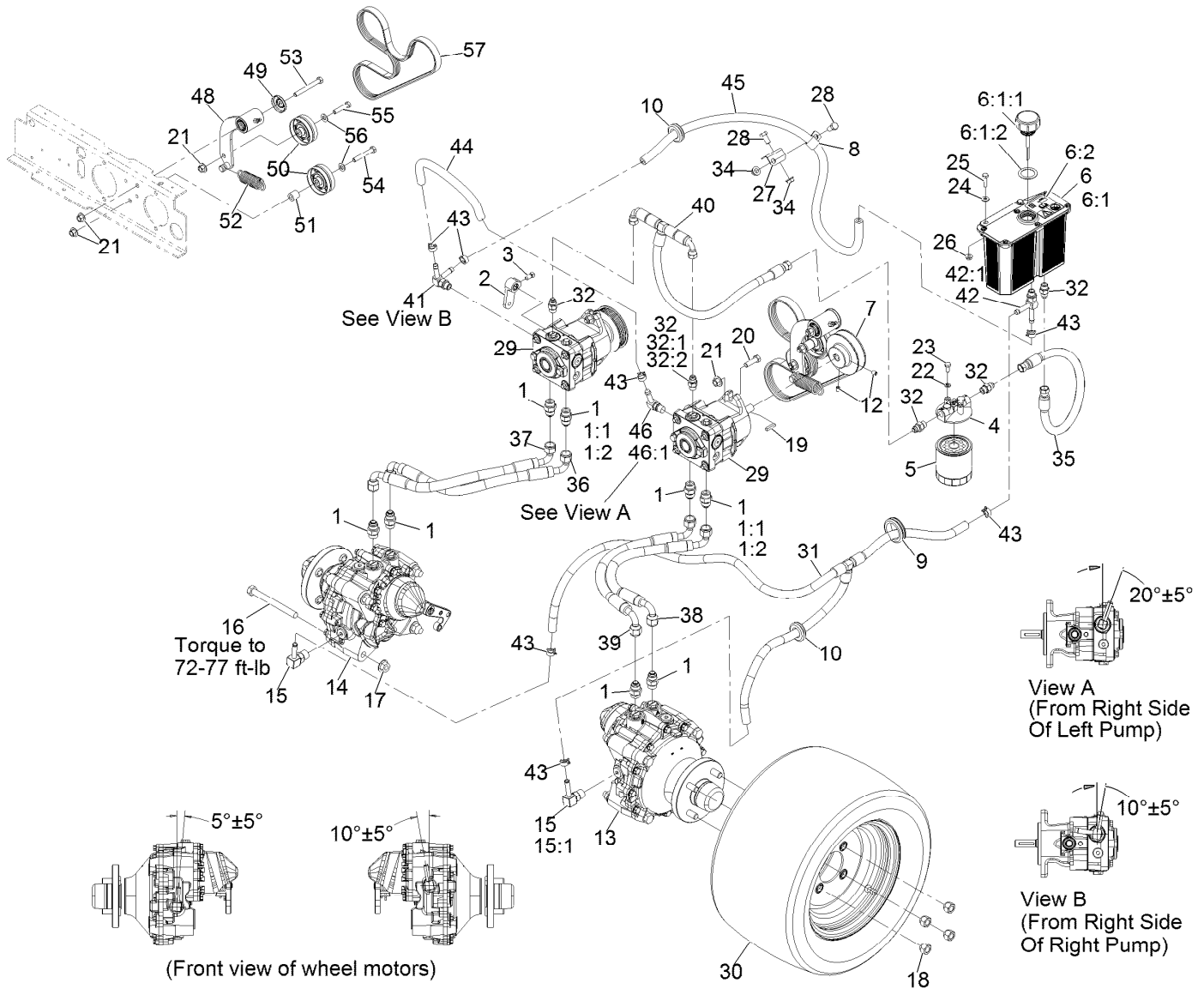

Hydraulic Assembly

Ref.	Part Number	Qty.	Description	Ref.	Part Number	Qty.	Description
1	1-603990	8	Adapter-Straight	13	116-7401	1	Motor-HYD H-Series, LH
1:1	1-603920	1	O-Ring-Sae #8	14	116-7402	1	Motor-HYD H-Series, RH
1:2	1-603992	1	O-Ring-37 Flare #8	15	354-134	2	Fitting-HYD, 90 DEG
2	1-632208	2	Arm-Control, Pump	15:1	237-79	1	O-Ring
3	120-6474	2	Screw-Set, SQH 5/16-18 X 3/4	16	325-19	8	Screw-HH 1/2-13 X 5
4	104-7836	1	Filter-Head	17	32128-49	8	Nut-Whizlock 1/2-13
5	109-4180	1	Element, Oil Filter	18	242-50	8	Nut-Lug 1/2-20
6	116-9274	1	Reservoir ASM W/Decal	19	1-807272	2	Key-5Mm X 5Mm X 25Mm
6:1		1	Reservoir-HYD ●	20	323-7	4	Screw-HH 3/8-16 X 1 1/4
6:1:1	116-9273	1	Cap-Reservoir, W/Gasket ASM	21	32128-43	7	Nut-Whizlock 3/8-16
6:1:2	103-1949	1	Gasket-Cap	22	1-805004	2	Washer-Lock 1/4 Heavy
6:2	115-4212	1	Decal-Warning	23	321-3	2	Screw-HH 1/4-20 X 5/8
7	103-4246	2	Sheave	24	3256-22	2	Washer-1/4 Sae
8	1-633396	1	Clip-Loom 5/8	25	321-6	2	Screw-HH 1/4-20 X 1
9	103-7706	1	Grommet	26	32128-33	2	Nut-Whizlock 1/4-20
10	1-543286	2	Grommet	27	103-8631	1	Bracket, Clamp
12	1-803310	4	Setscrew-5/16-18 X 3/8	28	323-4	2	Screw-HH 3/8-16 X 3/4
				29	116-7836	2	Pump-Hydro, 12Cc N-Type Nav Cs

● Not serviced separately

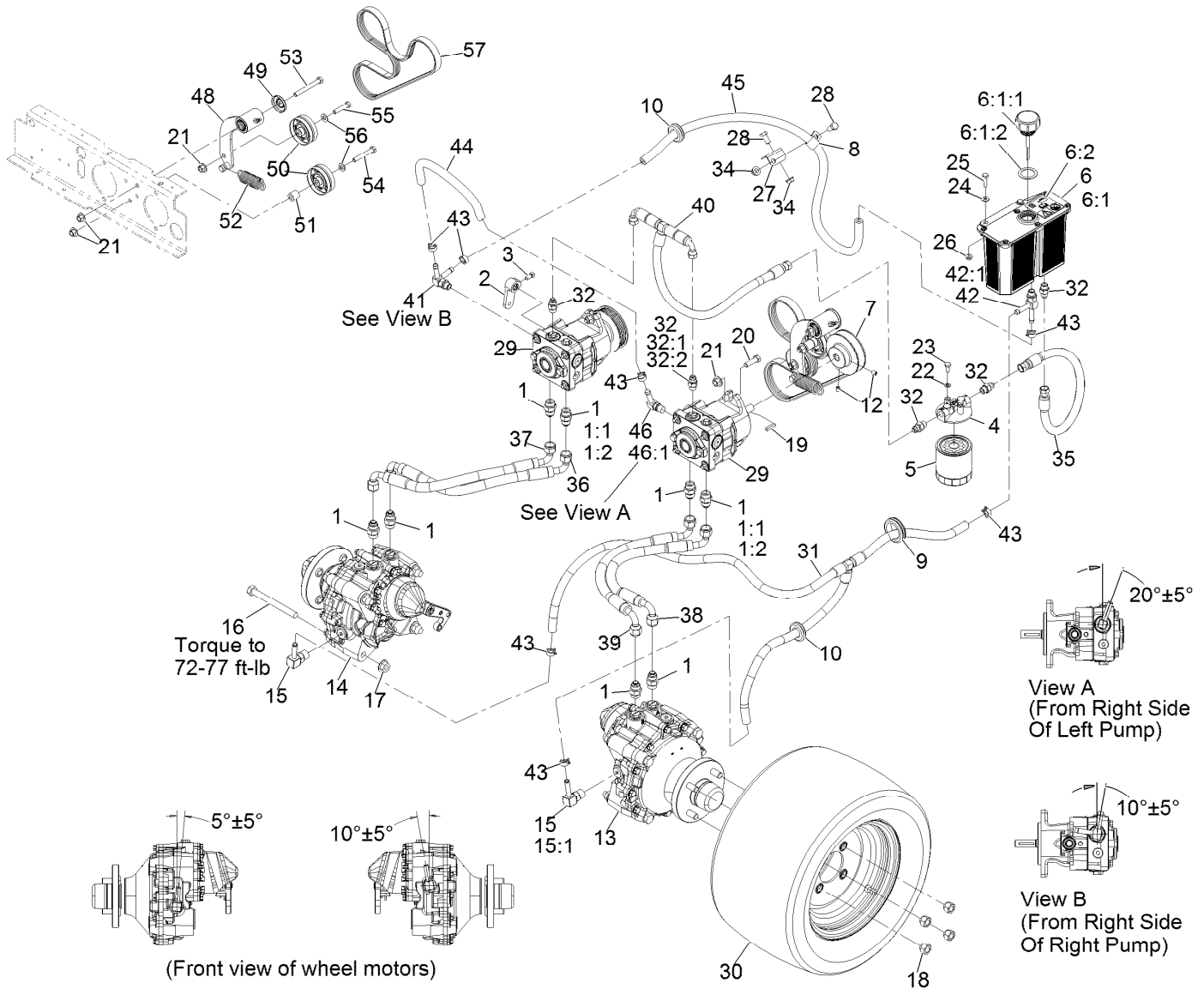

Hydraulic Assembly (continued)

Ref.	Part Number	Qty.	Description	Ref.	Part Number	Qty.	Description
30	116-5634	2	ASM-Tire And Wheel 18X10.5-10	43	103-1988	7	Clamp-Hose 11/16
31	116-7831	1	Hydraulic Hose ASM	44	103-5452	1	Hose, Hydraulic
32	103-2156	5	Adapter-Straight	45	103-5477	1	Hose, Hydraulic
32:1	1-603921	1	O-Ring-Sae #6	46	100-4887	1	Fitting-Barbed, 90 DEG
32:2	103-1020	1	O-Ring-37 Flare #6	46:1	237-42	1	O-Ring
34	3290-357	2	Nut-Whizlock 3/8-16	48	103-7349	1	Asm, Short Idler
35	109-1258	1	Hose, Hydraulic	49	103-2916	1	Guard-Top
36	116-7827	1	Hydraulic Hose ASM	50	116-6361	2	Pulley
37	116-7828	1	Hydraulic Hose ASM	51	106-5574	1	Spacer-Mounting, Steering
38	116-7829	1	Hydraulic Hose ASM	52	1-653331	1	Spring
39	116-7830	1	Hydraulic Hose ASM	53	323-20	1	Screw-HH 3/8-16 X 3-1/4
40	109-1264	1	Hose, Hydraulic	54	323-12	1	Screw-HH 3/8-16 X 2 1/2
41	103-5469	1	Adapter-Tee Special	55	323-9	1	Screw-HH 3/8-16 X 1 3/4
42	103-1828	1	Adapter-Running Tee	56	3256-24	2	Washer-3/8 Sae
42:1	237-42	1	O-Ring	57	103-4244	1	Belt

● Not serviced separately

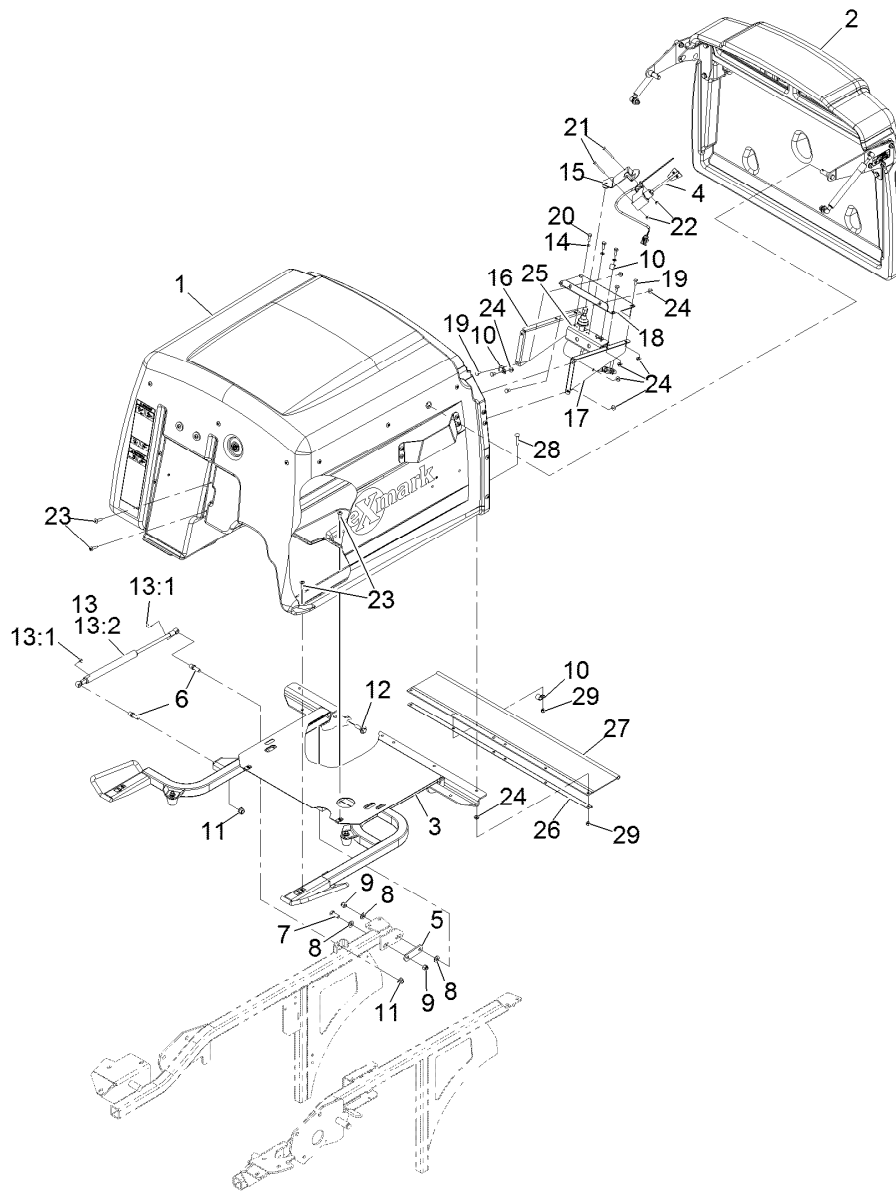

Hopper Assembly

Ref.	Part Number	Qty.	Description	Ref.	Part Number	Qty.	Description
1	103-9457	1	Asm, Hopper	15	109-3648	1	Wld, Switch Mount
2	103-9456	1	Asm, Door Hopper	16	103-6067-03	1	Bracket, Motor (LH)
3	109-4086	1	Asm, Hopper Frame	17	103-6068-03	1	Bracket, Motor (RH)
4	103-9466	1	Asm, Fill Sensor	18	103-7085-03	1	Plate, Switch
5	1-633068	2	Arm-Lift, Deck	19	321-2	7	Screw-HH
6	103-5426	2	Stud, Ball 13Mm	20	329-4	3	Screw-HH
7	323-6	2	Screw-HH	21	3250-48	2	Screw-PPH
8	3256-24	6	Washer-Flat	22	3296-2	2	Nut-Lock, NI
9	3296-39	4	Nut-Lock, NI	23	32105-32	8	Screw-TTH
10	1-513762	3	Clip-Loom	24	32128-33	17	Nut-HF
11	33005-00	2	Nut-HF	25	109-3853	1	Motor
12	614672	2	Bolt-Shoulder	26	103-6022-03	1	Channel, Hopper Frame
13	109-0716	1	Kit, Damper W/Clips	27	103-6025	1	Shield, Trailing
13:1	103-8325	2	Clip, Retainer-13Mm	28	3229-4	6	Screw-CARR
13:2	103-5425	1	Shock, Gas Compression	29	3296-42	6	Nut-Lock, NI
14	1-303435	3	Washer-Spring				

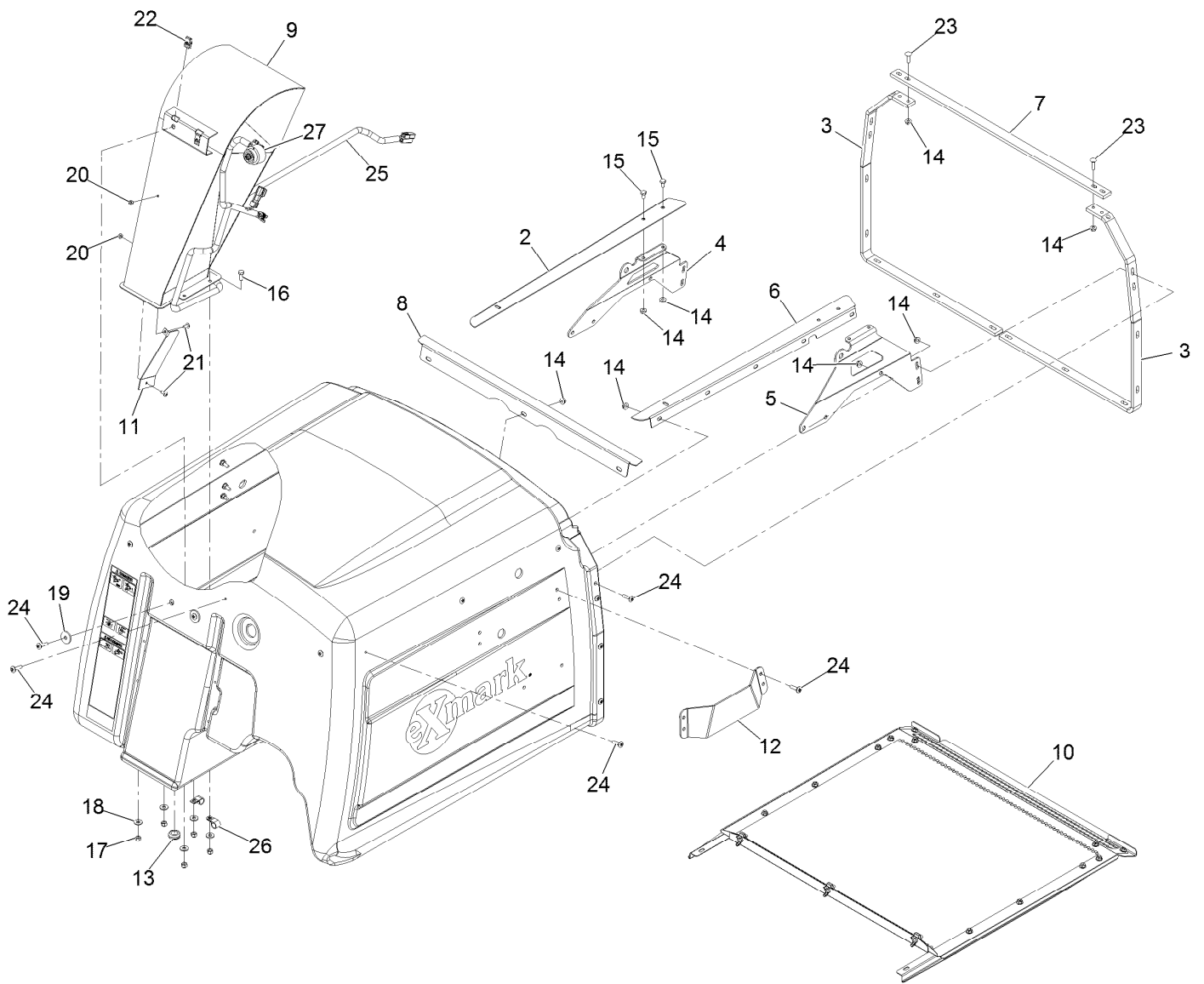

Hopper Assembly No. 103-9457

Ref.	Part Number	Qty.	Description	Ref.	Part Number	Qty.	Description
2	103-5736-03	1	Channel, Screen (RH)	16	321-4	5	Screw-HH 1/4-20 X 3/4
3	103-5045-03	2	Brace, Side	17	3296-42	5	Nut-Nyloc 1/4-20
4	103-5751-03	1	Panel, Hinge (RH)	18	3256-2	5	Washer-1/4 Std
5	103-5749-03	1	Panel, Hinge (LH)	19	1-613235	2	Washer
6	103-5774-03	1	Channel, Screen (LH)	20	3296-2	2	Nut-Nyloc #10-24
7	103-5772-03	1	Brace, Top	21	32122-30	2	Screw-Truss HD #10-24 X 1/2
8	103-7035-03	1	Channel, Screen Front	22	107069	2	Nut-Retainer-Panel 1/4-20
9	109-3650-03	1	Wld, Diffuser	23	3229-2	4	Bolt-Carriage 1/4-20 X 1
10	109-0717	1	Asm, Hopper Screen	24	32105-32	27	Screw-Truss HD 1/4-20 X 1
11	103-8680	1	Deflector, Discharge Chute	25	103-8800	1	Harness, Hopper Wire
12	109-4019	2	Guard, Damper	26	1-513762	2	Clip-Loom 1/2
13	1-543296	1	Grommet	27	103-0205	1	Alarm-Tone, Dual
14	32128-33	33	Nut-Whizlock 1/4-20				
15	321-2	4	Screw-HH 1/4-20 X 1/2				

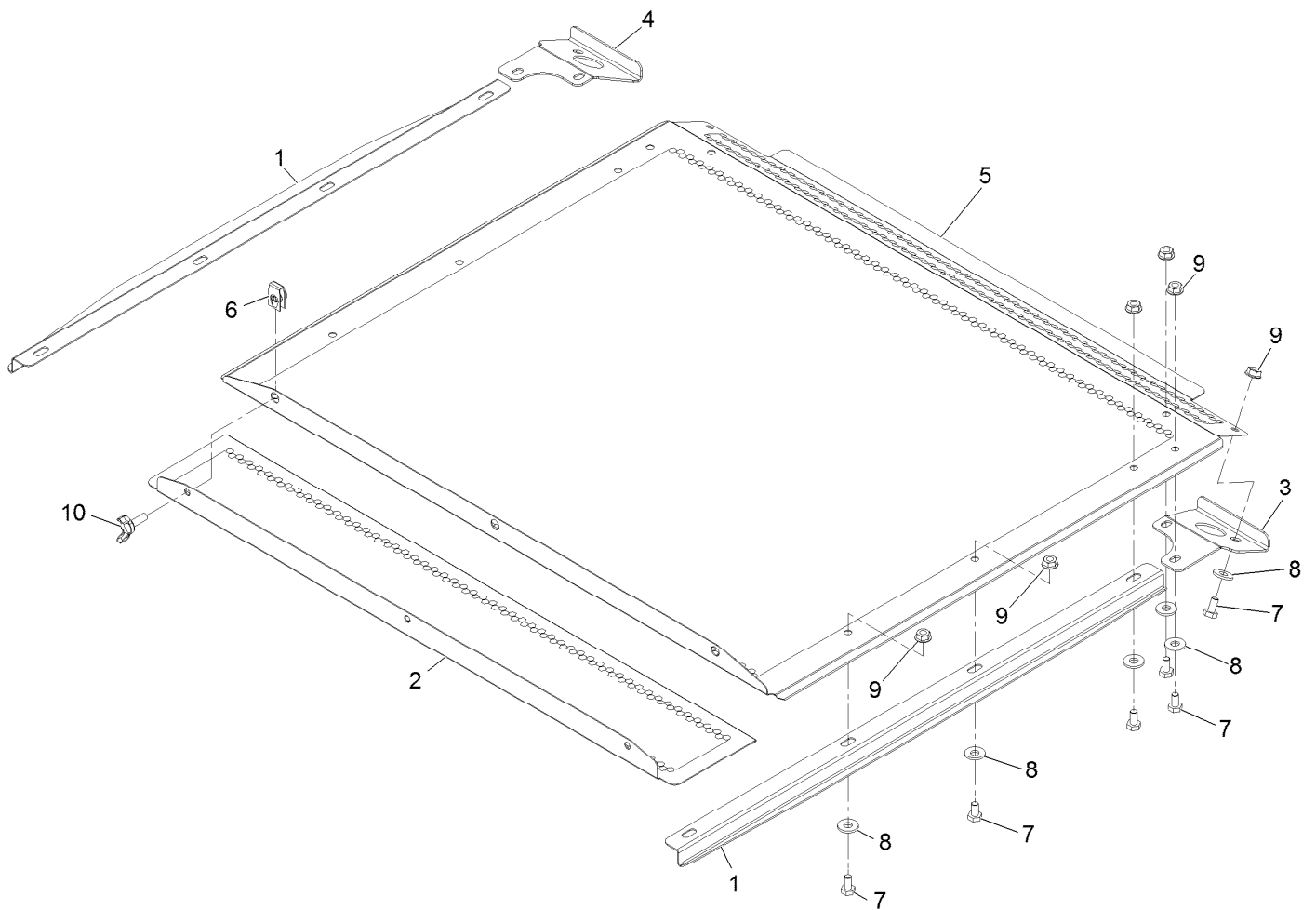

Hopper Screen Assembly No. 109-0717

Ref.	Part Number	Qty.	Description
1	103-8203-03	2	Guide, Screen
2	103-7048-03	1	Panel, Screen Extend
3	103-7098-03	1	Handle, Screen (LH)
4	103-7099-03	1	Handle, Screen (RH)
5	103-5745-03	1	Panel, Hopper Screen
6	107069	3	Nut-Retainer-Panel 1/4-20
7	321-2	12	Screw-HH 1/4-20 X 1/2
8	3256-2	12	Washer-1/4 Std
9	32128-33	12	Nut-Whizlock 1/4-20
10	109-1063	3	Screw-Wing 1/4-20 X 3/4

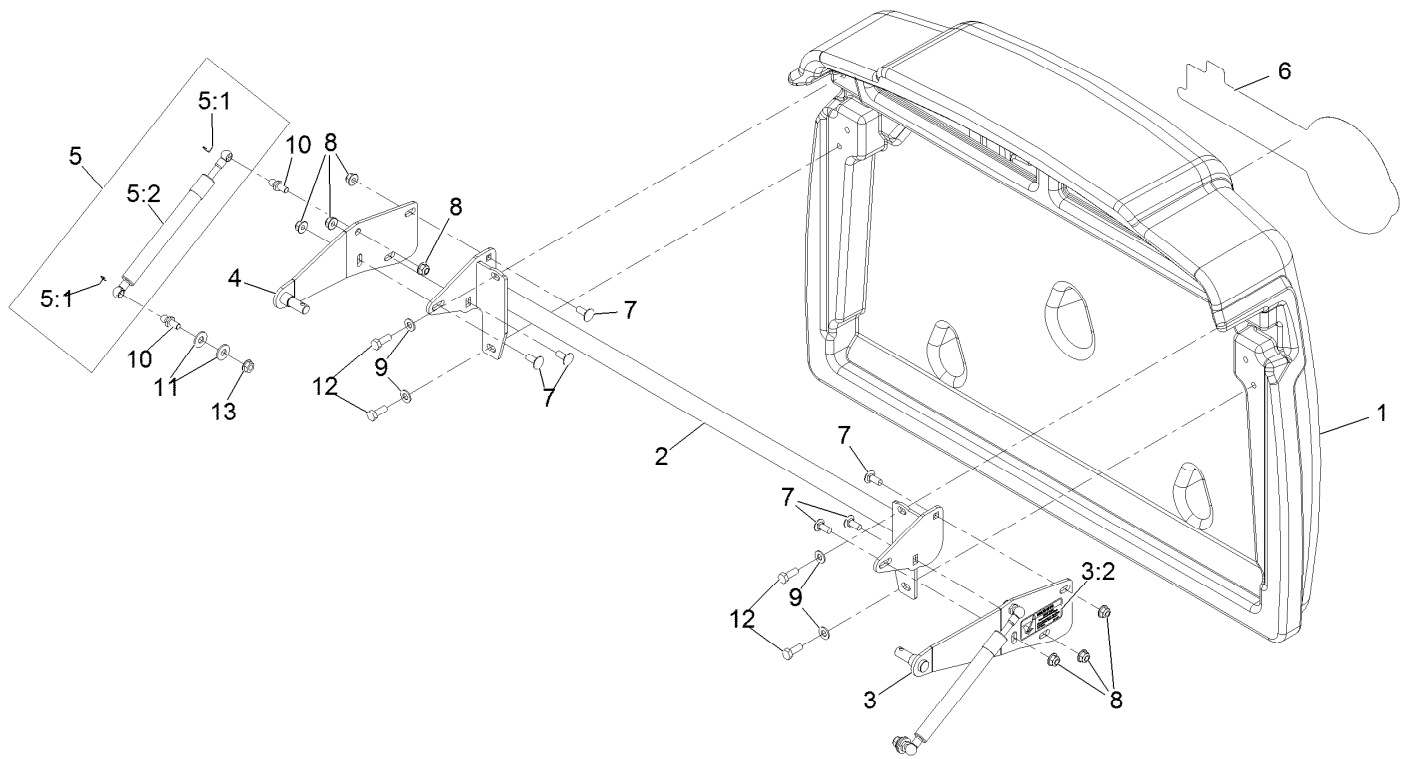

Hopper Door Assembly No. 103-9456

Ref.	Part Number	Qty.	Description	Ref.	Part Number	Qty.	Description
1	109-3955	1	Door, 9.5 Bushel Hopper	6	103-6024	1	Decal, Exmark Logo
2	109-4153-03	1	Wld, Door Support	7	3230-23	6	Bolt-Carriage 5/16-18 X 3/4 Short Neck
3	109-4253	1	Asm, Door Pivot W/Decal (LH)	8	104-8300	8	Nut-Nyloc 5/16-18 Flg
3:2	103-8444	1	Decal, Pinch Point	9	3256-23	4	Washer-5/16 Sae
4	109-4254	1	Wld, Door Pivot W/Decal (RH)	10	103-5752	4	Stud-Ball 10Mm
5	109-0715	2	Kit, Damper W/Clips	11	3256-3	4	Washer-5/16 Std
5:1	103-8324	2	Clip-Retainer-10Mm	12	322-4	4	Screw-HH 5/16-18 X 7/8
5:2	103-5746	1	Shock, Gas Tension	13	32128-20	2	Nut-Whizlock 5/16-18

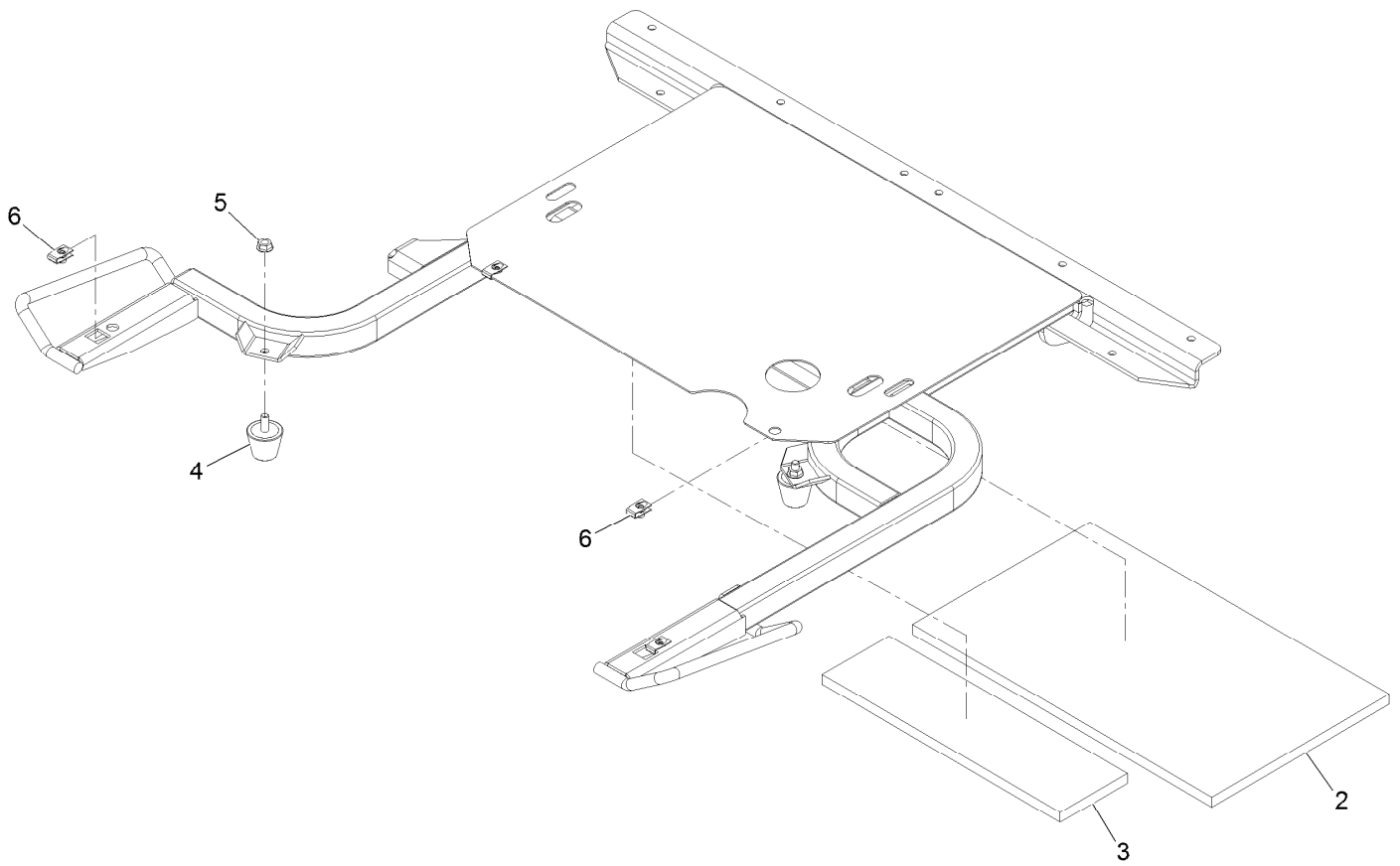

Hopper Frame Assembly No. 109-4086

<i>Ref.</i>	<i>Part Number</i>	<i>Qty.</i>	<i>Description</i>
2	103-7824	1	Insulation, Foam Pad Rear
3	103-7825	1	Insulation, Foam Pad Front
4	1-543963	2	Bumper, Rubber
5	32128-20	2	Nut-Whizlock 5/16-18
6	107069	4	Nut-Retainer-Panel 1/4-20

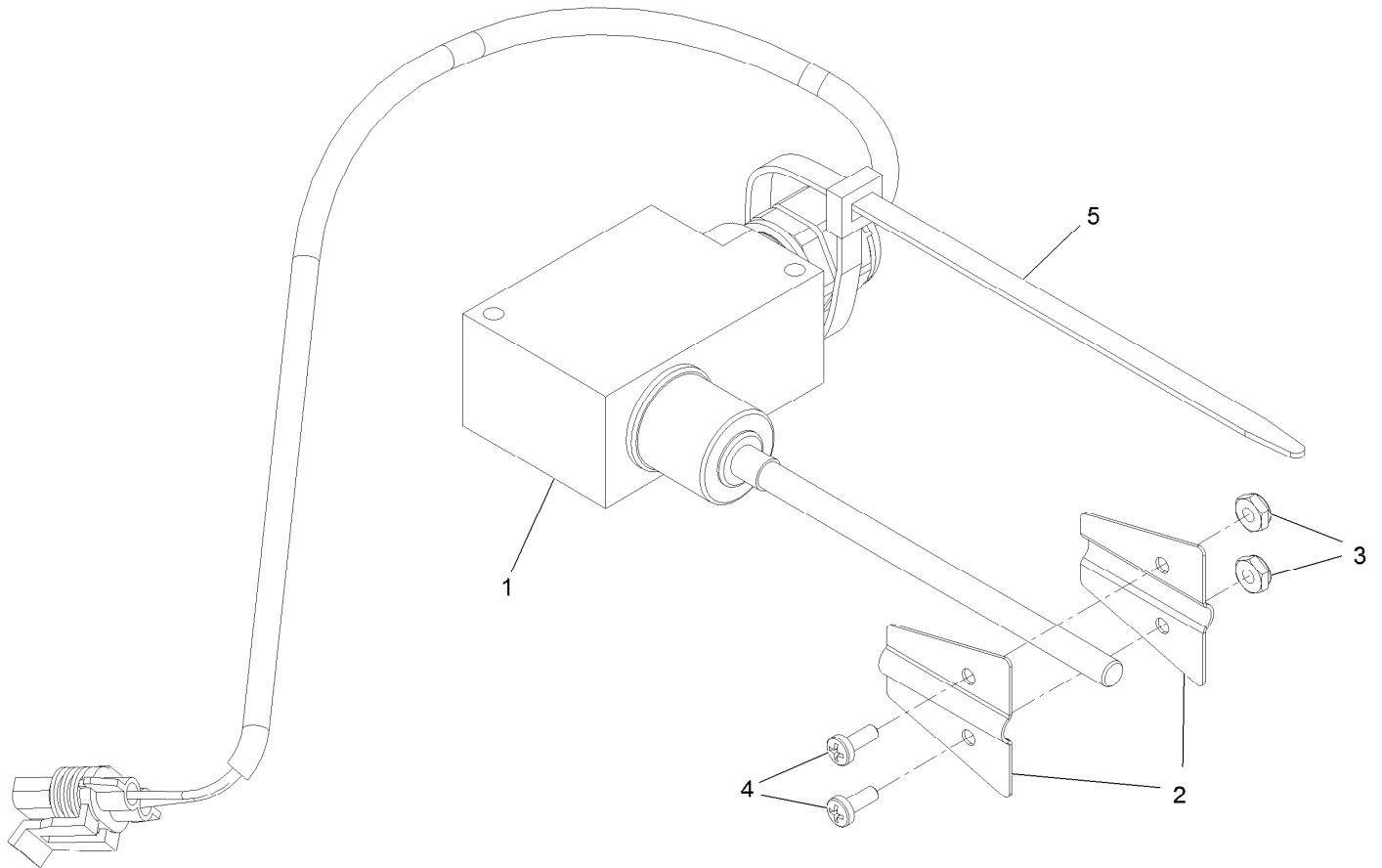

Fill Sensor Assembly No. 103-9466

<i>Ref.</i>	<i>Part Number</i>	<i>Qty.</i>	<i>Description</i>
1	109-3854	1	Kit, Fill Sensor Wire
2	103-8789	2	Flag, Fill Sensor
3	3296-9	2	Nut-Nyloc #6-32 Thin
4	9107622	2	Screw-PPH #6-32 X 5/8
5	1-303335	1	Tie-Cable 7 15/16 (Large)

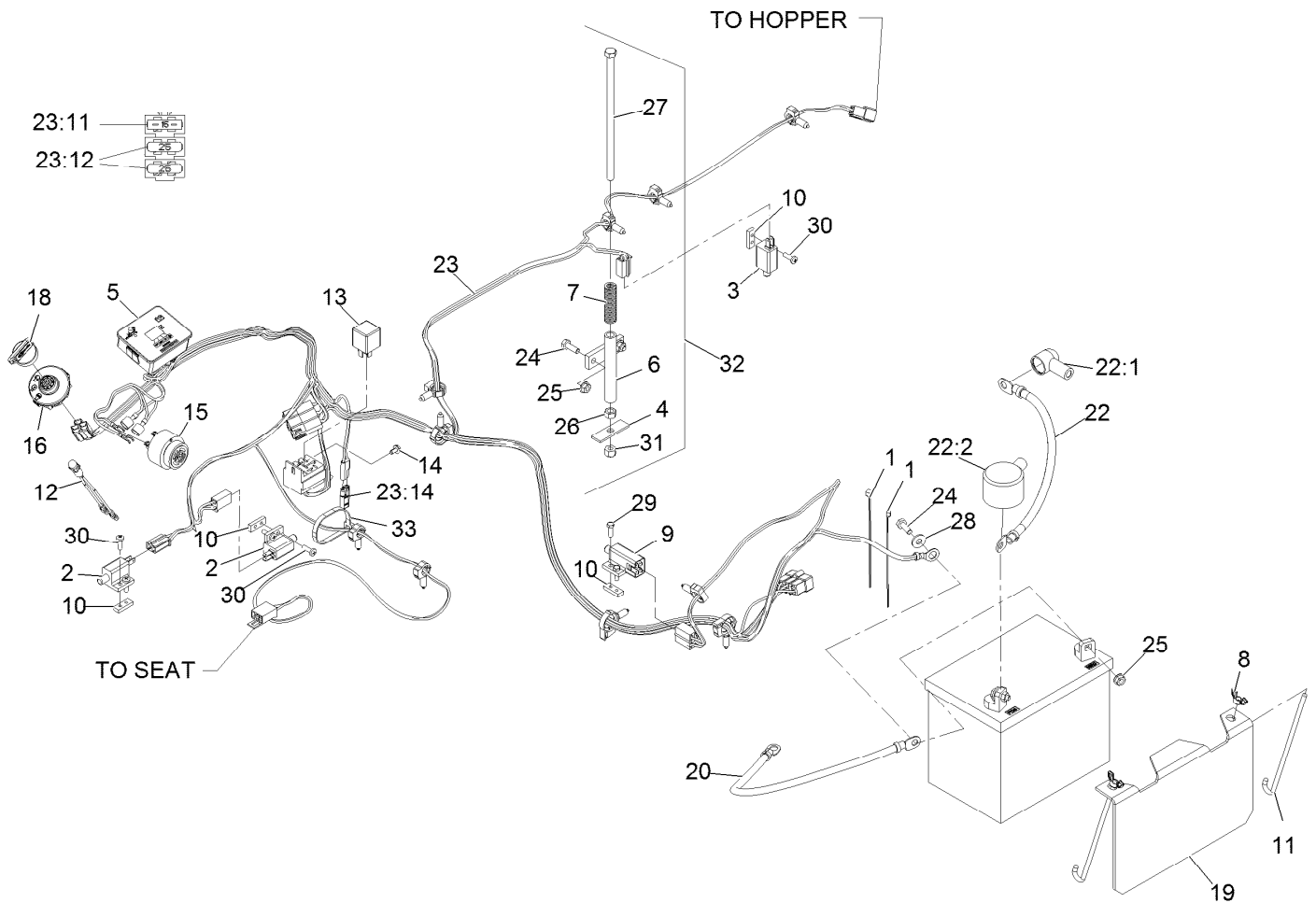

Electrical Assembly

Ref.	Part Number	Qty.	Description	Ref.	Part Number	Qty.	Description
1	1-303287	2	Tie-Cable 5 1/2 (Small)	22	116-4730	1	Cable-Battery Positive
2	1-513051	2	Switch-N.O.	22:1	1-543393	1	Insulator-Solenoid
3	1-513152	1	Switch-N.C.	22:2	109-2407	1	Insulator-Battery
4	1-513180	1	Plate-Switch, Seat	23	116-9114	1	Harness-Wiring Navigator ●
5	116-8812	1	Navigator Hour Meter ASM	23:11	109355	1	Fuse-Blade, 15 Amp
6	1-522424-03	1	Mount-Spring, Seat	23:12	109102	2	Fuse-Blade, 25 Amp
7	1-523415	1	Spring	23:14	116-0053	1	Cap-Plug
8	1-543792	2	Wingnut-Nyloc 1/4-20	24	321-4	4	Screw-HH 1/4-20 X 3/4
9	1-633111	1	Switch	25	32128-33	4	Nut-Whizlock 1/4-20
10	1-633181	4	Plate-Tapped	26	3217-6	1	Nut-Hex 5/16-18
11	1-633651	2	Bolt-Holddown	27	322-50	1	Screw-HH 5/16-18 X 7 1/2
12	1-643267	1	Indicator-Red Led	28	3256-2	2	Washer-1/4 Std
13	1-643275	1	Relay-12Vdc 40 Amp	29	3290-134	2	Screw-HH Machine 10-24 X 5/8
14	104-2065	1	Screw-HWH #10-24 X 3/8	30	3290-500	6	Screw-PPH #10-24 X 5/8
15	103-0205	1	Alarm-Dual Tone 12Vdc	31	3296-29	1	Nut-Nyloc 5/16-18
16	117-2221	1	Switch-Ignition	32	103-8528	1	Asm, Hopper Switch Actuator
18	103-2106	1	Key-Exmark Logo	33	1-303335	1	Tie-Cable 7 15/16 (Large)
19	103-4161-03	1	Hold Down, Battery				
20	103-8355	1	Cable-Ground(-)				

● Use dielectric grease on all unsealed connectors and terminals only. Do not apply in sealed connectors.

EXMARK® MAINTENANCE

MAXIMIZE THE PERFORMANCE OF YOUR EXMARK.

4-CYCLE PREMIUM ENGINE OIL

Part No. 116-3373

Both SAE 30 and SAE 10W-30 in one bottle.

Contains increased levels of zinc and phosphorus for better lubricity.

No Viscosity Index Improvers that tend to shear down in high heat.

Synthetic formulation.

Gas & Diesel compatible.

Anti-corrosion additives.

API 'SL' and JASO rated with wet clutch compatibility for other machines.

PREMIUM HYDRO OIL

Part No. 109-9828

Commercial quality for tough, high-heat conditions.

Designed specifically for zero-turn mower hydraulic systems.

Superior shear resistance under heavy loads.

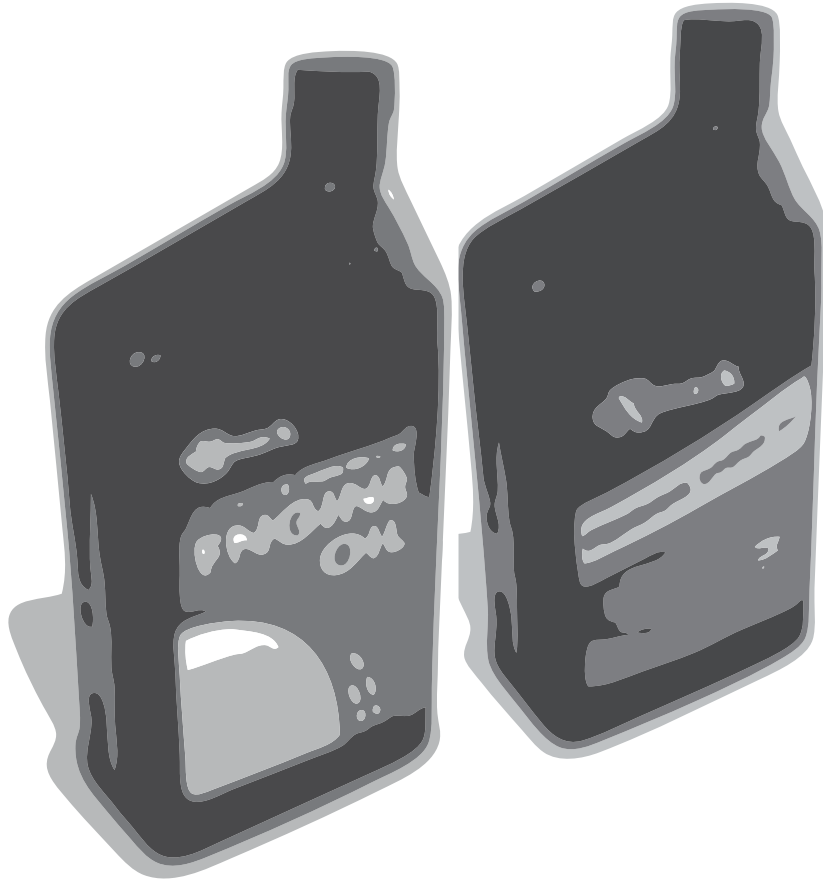

Available from your local Exmark dealer. Find your closest dealer at exmark.com

EXMARK ACCESSORIES AND OPTIONS*

MID-MOUNT RIDING ACCESSORIES AND OPTIONS

CUSTOM RIDE SEAT SUSPENSION SYSTEM	OPERATOR CONTROLLED DISCHARGE
FULL SUSPENSION SEAT	SUN SHADE
DECK LIFT ASSIST KIT	TRASH CONTAINER
HITCH KIT	TURF STRIPER
LIGHT KIT	ULTRA VAC COLLECTION SYSTEM
12V POWER PORT	ULTRA VAC QUICK DISPOSAL SYSTEM
MICRO-MULCH SYSTEM	

OUT-FRONT RIDING ACCESSORIES AND OPTIONS

CUSTOM RIDE SEAT SUSPENSION SYSTEM	SNOW BLADE
DUAL-TAIL WHEEL	SNOWBLOWER
FLOOR PAN EXTENDER	SUN SHADE
HITCH KIT	TRASH CONTAINER
LIGHT KIT	ULTRA VAC COLLECTION SYSTEM
MICRO-MULCH SYSTEM	ULTRA VAC QUICK DISPOSAL SYSTEM
ROLL OVER PROTECTION SYSTEM (ROPS)	WEATHER CAB

WALK-BEHIND ACCESSORIES AND OPTIONS

GRASS CATCHER	TURF STRIPER
MICRO-MULCH SYSTEM	STANDON

*Some accessories and options not available for some models.

Place Model No. and Serial No.
Label Here (Included in the Literature
Pack) or Fill in Below

Model No. _____

Serial No. _____

Date Purchased _____

Engine Model No. and Spec. No. _____

Engine Serial No. (E/No) _____

© 2013 Exmark Mfg. Co., Inc.
Industrial Park Box 808
Beatrice, NE 68310
All Rights Reserved

Part No. 4501-548 Rev. C
(402) 223-6300
Fax (402) 223-5489
Printed in the USA.

