



Count on it.

Parts Catalog

**Commercial Walk-Behind Mower
Fixed Deck, Pistol Grip, Gear Drive with 36in
TURBO FORCE® Cutting Unit**

Model No. 39634—Serial No. 314000001 and Up



Ordering Replacement Parts

To order replacement parts, please supply the part number, the quantity, and the description of each part desired.

Understanding Reference Numbers

Each identified part in an illustration has a reference number. The reference number for a part also appears in the parts list, along with other information about the part.

This catalog uses two special reference number formats, one to indicate parts in a service assembly and another to indicate the quantity of a given part in an illustration.

Service Assembly Reference Numbers

Parts in service assemblies have reference numbers in the form a:b. The a represents the reference number of the entire service assembly and the b represents a sequential number unique to each part within the service assembly.

For example, a wheel assembly might be identified by reference number 6, the tire by 6:1, the valve by 6:2, and the wheel by 6:3. When you order the assembly identified by reference number 6, you receive all parts identified by reference numbers 6:1, 6:2, and 6:3. However, you may also order any part individually. Reference numbers of this type appear in illustration and in parts lists.

Reference Numbers Indicating Quantity

In an illustration, if a reference number indicates more than one part, the reference number has the form nX y. The n represents the quantity of the part, the X is the multiplication symbol, and the y represents the reference number.

For example, in an illustration, the reference number 2X 37 means that two of the parts identified by reference number 37 are indicated.

List of Abbreviations

AR: as required

ASM: assembly

BBC: blade brake control

BHTF: button head thread forming

CARR: carriage

CCW: counter clockwise

CW: clockwise

DEG: degrees

DPA: Dual Point Adjustment

ECM: electronic control module

EXT: external

FH: flat head

GA: gauge

HD: heavy-duty

HF: hex flange

HH: hex head

HHF: hex head flange

HHFTF: hex head flange thread forming

HJ: hex jam

HLH: hex lag head

HOC: height-of-cut

HSBH: hex socket button head

HSFH: hex socket flat head

HSH: hex socket head

HWH: hex washer head

HWHTF: hex washer head thread forming

HYD: hydraulic

LH: left hand

LP: Liquefied Petroleum Gas

LPG: Liquefied Petroleum Gas

NI: nylon insert

NPTF: national pipe thread fine

PFH: phillips flat head

PPH: phillips pan head

PPHTF: phillips pan head thread forming

PRH: phillips round head

PTH: phillips truss head

PTO: power-take-off

RH: right hand

ROPS: roll-over protection system

RRB: rear roller brush

SFH: slotted fillister head

SHH: slotted hex head

SHWH: slotted hex washer head

SPH: slotted pan head

SQH: square head

SRH: slotted round head

STD: standard

TAP: self tapping

TTH: torx truss head

Contents

Engine and Exhaust Assembly.....	4
Fuel System Assembly	6
Frame and Transmission Assembly	7
Drive Wheel and Brake Assembly	9
Handle Control Assembly	11
Handle Assembly	12
Deck Assembly	13
Deck Decal Assembly No. 110-4907.....	14
Deflector Assembly No. 119-6530.....	15
Sheave, Spindle and Blade Assembly	16
Idler Assembly	17
Caster Assembly	18
Attachments and Accessories	19

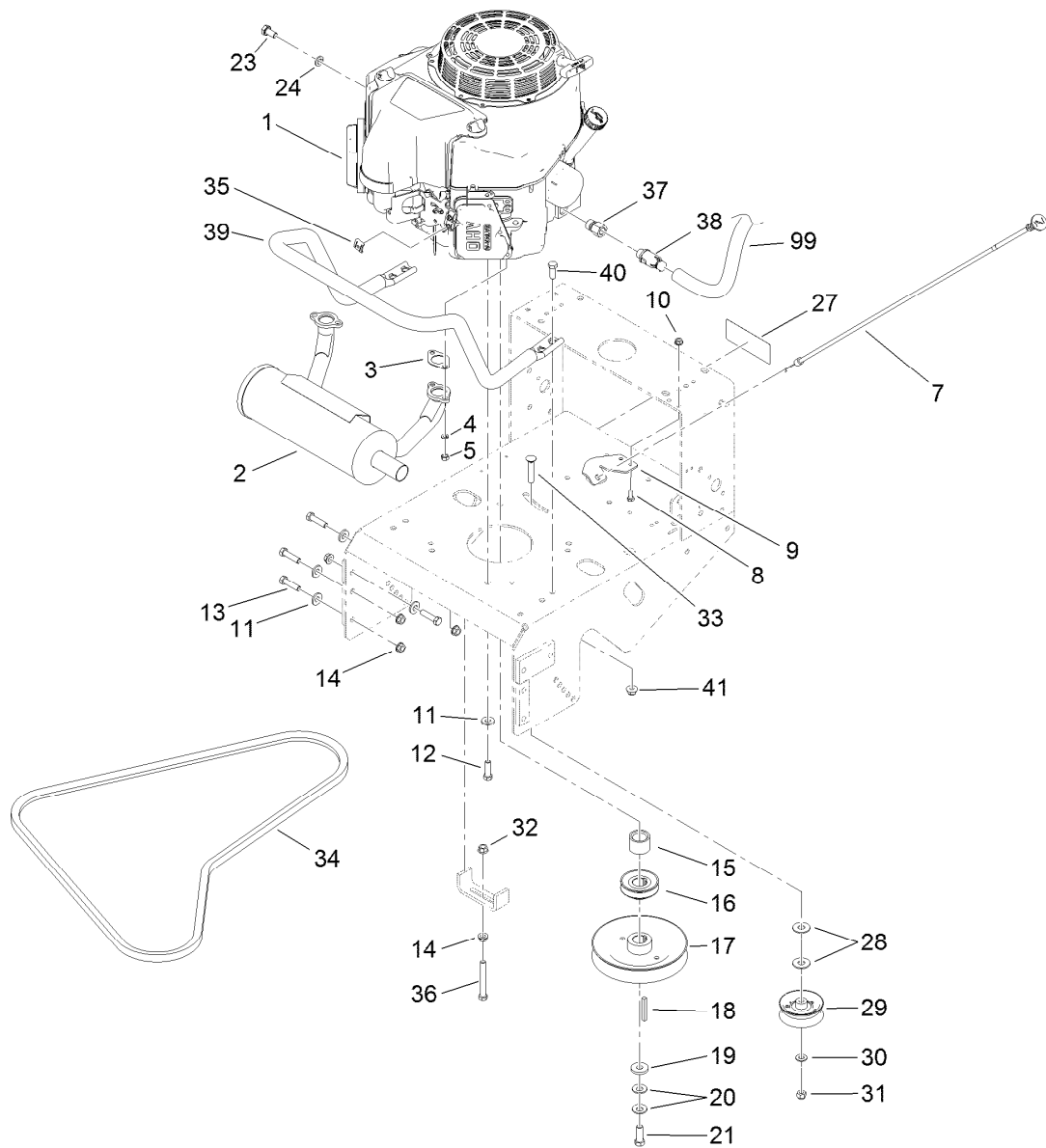

Engine and Exhaust Assembly

Ref.	Part Number	Qty.	Description	Ref.	Part Number	Qty.	Description
1		1	Engine-Kawasaki, Fs481V-As06 ●■	19	1-373034	1	Washer
2	116-3734	1	Muffler-Horizontal, Offset	20	1-603610	2	Washer-Spring
3	1-653313	2	Gasket-Exhaust	21	116-3702	1	Screw-HH
4	114-3550	4	Washer-Lock, Spring	23	33114-016	1	Screw-HH
5	114-3549	4	Nut	24	3253-4	1	Washer-Lock
7	103-1796	1	Cable-Choke	27	98-0776	1	Decal-Caution
8	321-3	2	Screw-HH	28	3256-5	2	Washer-Flat
9	103-1797-01	1	Bracket-Cable, Choke	29	1-323285	1	Pulley-Idler, Flat
10	32128-33	2	Nut-HF	30	3256-24	1	Washer-Flat
11	98-5975	12	Washer-Belleville	31	3296-39	1	Nut-Lock, NI
12	323-7	4	Screw-HH	32	32128-21	1	Nut-HF
13	323-8	8	Screw-HH	33	3231-6	1	Screw-CARR
14	3290-357	9	Nut-HHF, Whiz	34	110-4886	1	Belt-V
15	1-633453	1	Spacer-Clutch	35	81-1690	1	Clamp-Cable
16	103-1666	1	Spave-Transmission	36	323-14	1	Screw-HH
17	110-4891	1	Pulley	37	103-1966	1	Adapter
18	103-4177	1	Key	38	120-4321	1	Valve-Drain, Oil
				39	116-6278-03	1	Guard-Muffler

● Not serviced separately

■ Obtain parts from www.kawpowerpc.com

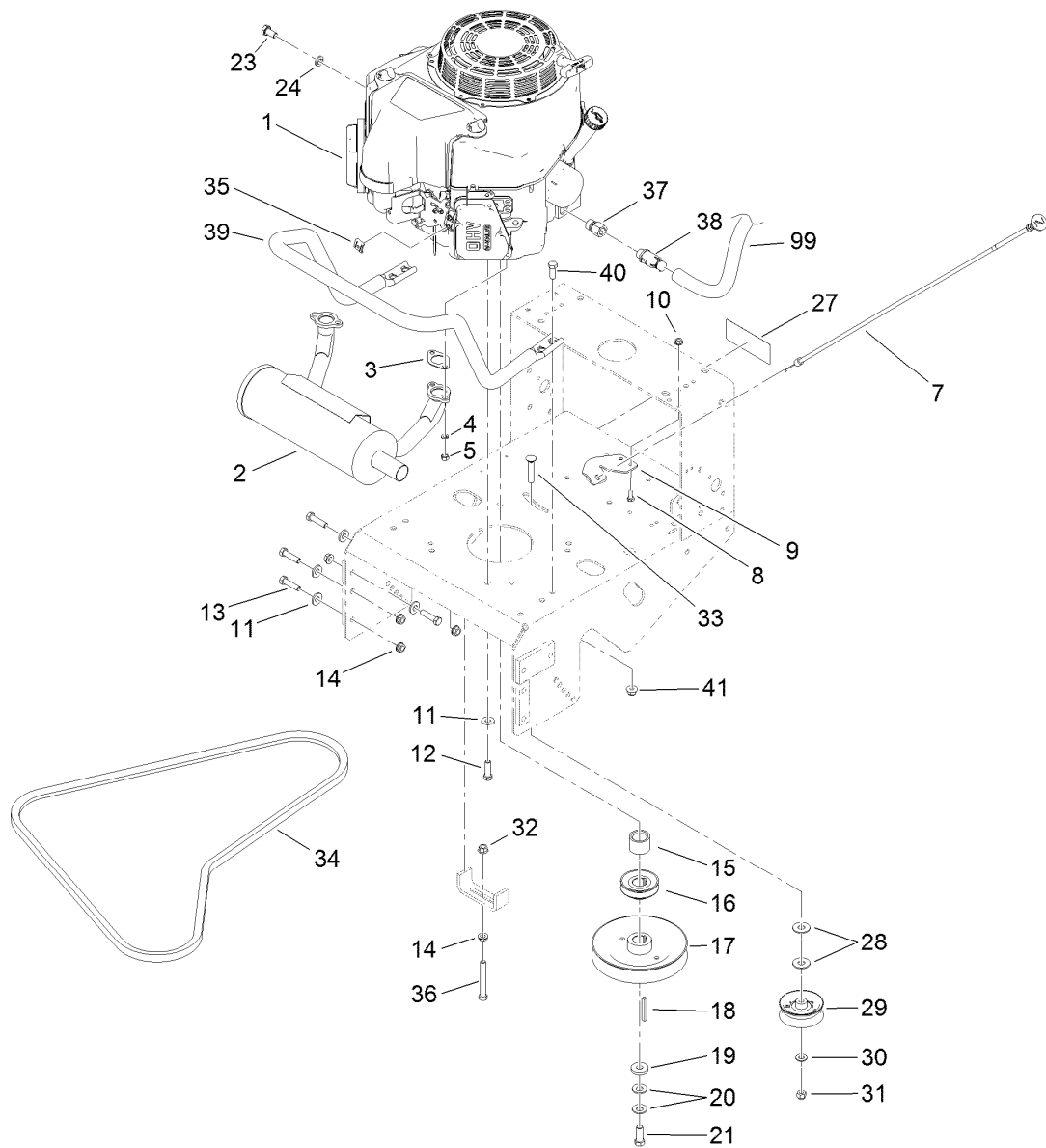

Engine and Exhaust Assembly (continued)

Ref.	Part Number	Qty.	Description
40	323-6	4	Screw-HH

Ref.	Part Number	Qty.	Description
41	104-8301	4	Nut-Flange, NI
99	103-1964	1	Hose-Drain, Oil

● Not serviced separately

■ Obtain parts from www.kawpowerpc.com

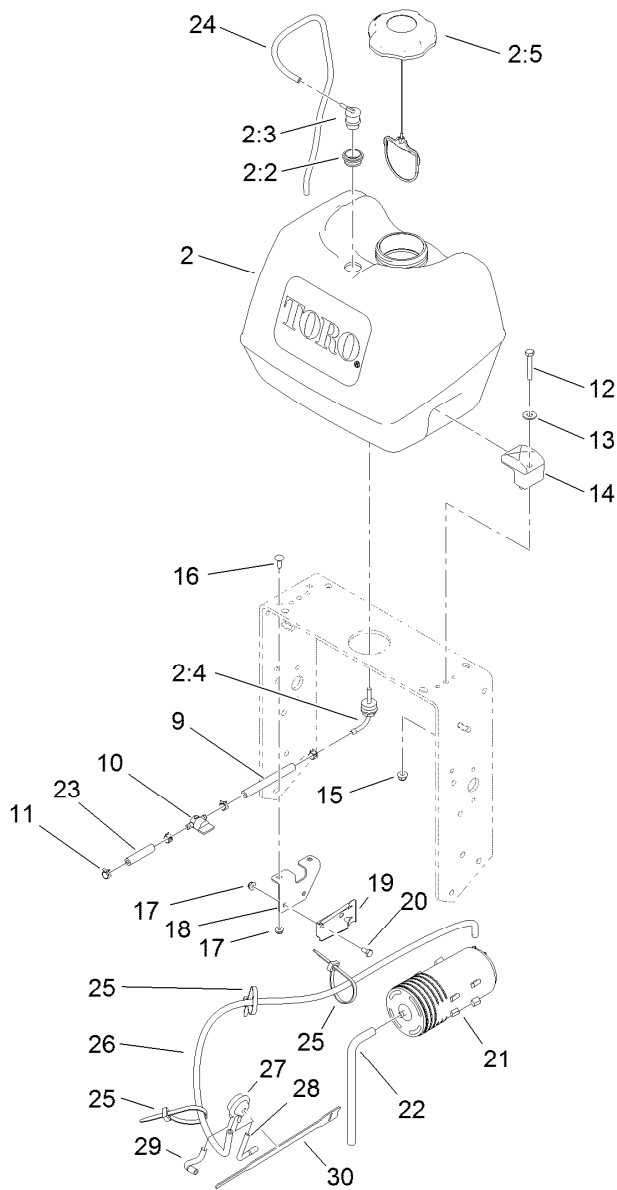

Fuel System Assembly

<i>Ref.</i>	<i>Part Number</i>	<i>Qty.</i>	<i>Description</i>	<i>Ref.</i>	<i>Part Number</i>	<i>Qty.</i>	<i>Description</i>
2	126-1526	1	Fuel Tank ASM	18	115-4486-01	1	Bracket-Canister, Carbon
2:2	114-0284	1	Grommet	19	114-0292	1	Bracket-Canister, Carbon
2:3	119-3547	1	Valve-Vent, Fuel	20	321-2	2	Screw-HH
2:4	103-2605	1	Fitting-Fuel, Bulkhead	21	117-1221	1	Canister-Carbon, 800Cc
2:5	120-5461	1	Cap-Fuel, Ratcheting	22	115-0962	1	Hose-Vent, Canister
9	109-0650	1	Hose-Fuel	23	99-9415	1	Hose-Fuel
10	1-603770	1	Valve-Fuel	24	114-0286	1	Hose-Vent
11	2412-98	4	Clamp-Hose	25	3290-378	3	Tie-Cable
12	322-10	2	Screw-HH	26	116-2231	1	Hose-Vent, Formed
13	3256-3	2	Washer-Flat	27	116-2232	1	Valve-Control, Vacuum
14	107-4543	2	Clamp	28	119-8501	1	Hose-Vent, Formed
15	104-8300	2	Nut-Flange, NI	29	119-8502	1	Hose-Vent, Formed
16	3229-1	2	Bolt-CARR	30	116-2469	1	Strap-Velcro, Cable Tie
17	104-7201	4	Nut-HF				

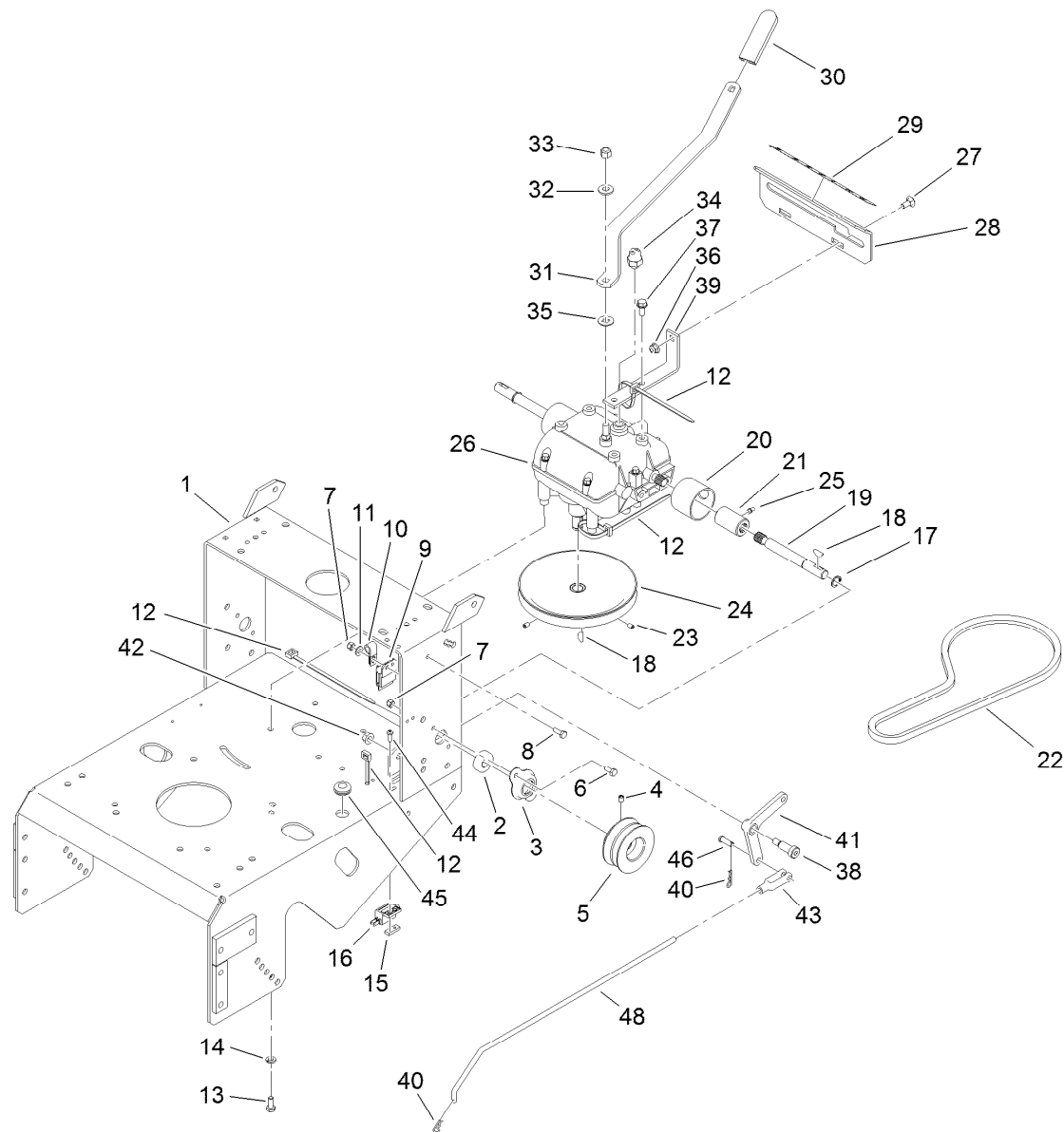

Frame and Transmission Assembly

Ref.	Part Number	Qty.	Description	Ref.	Part Number	Qty.	Description
1	116-6084-01	1	Frame-Gear	22	1-323630	1	V-Belt
2	1-323252	2	Bearing-Shaft	23	3245-41	2	Screw-HSH
3	1-323254	2	Flange-Output	24	1-323278	1	Sheave-Transmission
4	3246-18	2	Setscrew	25	302-19	2	Fitting-Grease
5	103-6511	2	Sheave-Transmission	26	1-323500	1	Transmission
6	321-3	4	Screw-HH	27	3230-1	2	Bolt-CARR
7	3296-42	5	Nut-Lock, NI	28	1-323387-03	1	Plate-Shift
8	321-4	1	Screw-HH	29	105-4104	1	Decal-Speed, Ground
9	1-323430	1	Module-Interlock	30	1-303020	1	Grip-Lever
10	1-513762	1	Clip-Loom	31	98-3274-03	1	Lever-Shift
11	3256-22	1	Washer-Flat	32	98-5975	1	Washer-Belleville
12	1-303335	3	Tie-Plastic	33	3296-6	1	Nut-Lock
13	322-3	4	Screw-HH	34	1-303282	1	Switch-Start, Neutral
14	1-805005	4	Washer-Lock	35	1-323379	1	Washer
15	1-633181	1	Plate-Tapped	36	104-8300	2	Nut-Flange, NI
16	1-513051	1	Switch-Open, Normally	37	32144-11	4	Screw-HWHTF
17	32151-62	2	Ring-Retaining	38	1-603403	1	Bolt-Shoulder
18	3257-5	3	Key-Woodruff	39	1-323389-03	2	Bracket-Plate, Shift
19	1-323502	2	Shaft-Transmission	40	1-806003	2	Pin-Cotter, Hair
20	51-4220	2	Guard-Coupler	41	1-303186	1	Bellcrank
21	1-323680	2	Coupler	42	3290-357	1	Nut-HHF, Whiz

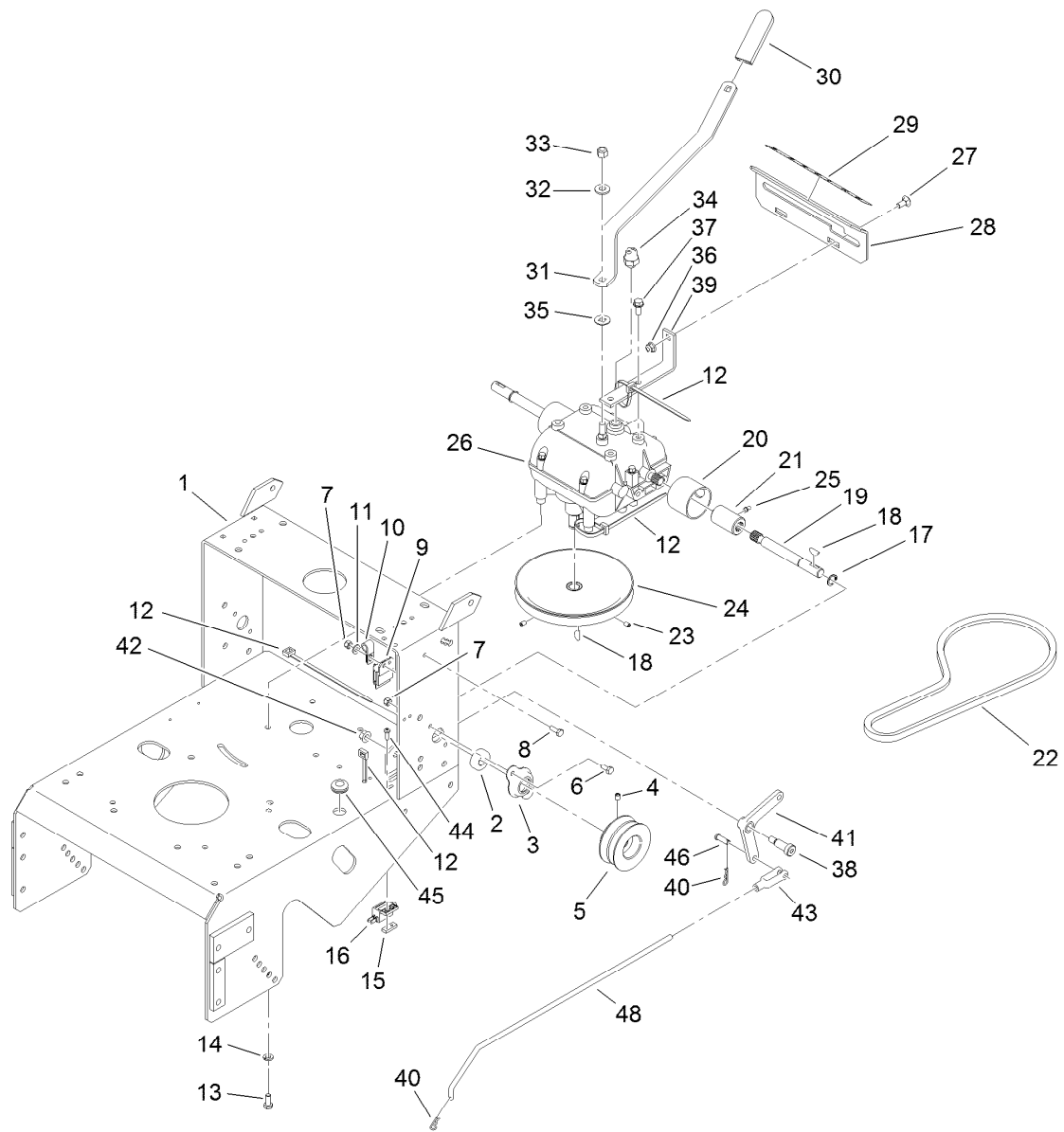

Frame and Transmission Assembly (continued)

<i>Ref.</i>	<i>Part Number</i>	<i>Qty.</i>	<i>Description</i>	<i>Ref.</i>	<i>Part Number</i>	<i>Qty.</i>	<i>Description</i>
43	1-303105	1	Yoke-Adjustable	46	1-808280	1	Pin-Clevis
44	3290-500	2	Screw-PPH	48	1-323303	1	Arm-Assist, Linkage
45	1-543296	1	Grommet				

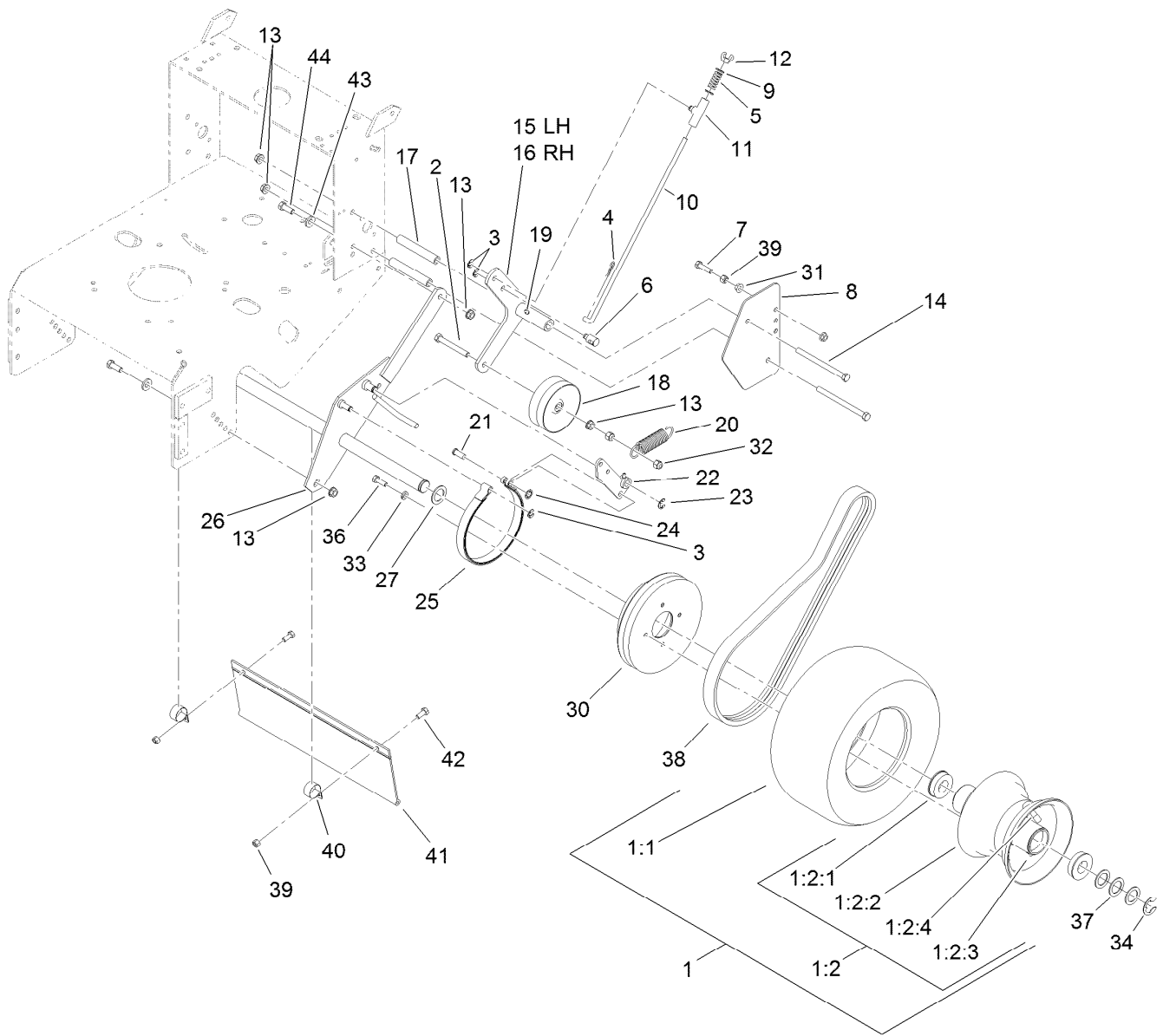

Drive Wheel and Brake Assembly

Ref.	Part Number	Qty.	Description	Ref.	Part Number	Qty.	Description
1	130-4550	2	Wheel And Tire ASM	13	3290-357	10	Nut-HHF, Whiz
1:1	1-323720	1	Tire-Turfmaster	14	323-39	4	Screw-HH
1:2	130-4565	1	Wheel And Hub ASM	15	116-7542-03	1	Arm-Idler, LH
1:2:1	1-323329	2	Bearing-Flanged	16	116-7543-03	1	Arm-Idler, RH
1:2:2		1	Rim ASM ●	17	1-323283	4	Spacer-Shield
1:2:3		1	Fitting-Grease ●	18	119-7887	2	Pulley-Idler
1:2:4		1	Stem-Valve ●	19	302-19	2	Fitting-Grease
2	99-8664	2	Screw-HH	20	1-603402	2	Spring-Extension
3	32151-47	6	Ring-Retaining	21	1-323307	2	Pin-Clevis
4	1-806003	2	Pin-Cotter, Hair	22	103-1611-03	2	Arm-Brake
5	1-323245	2	Spring-Compression	23	32120-47	2	Ring-Retaining, External
6	103-1864	2	Swivel-Lever, Drive	24	1-803051	2	Nut-Push
7	116-3515	2	Screw-HH, Special	25	1-323262	2	Band-Brake
8	1-323287-01	2	Shield-Wheel, Drive	26	1-322117-03	1	Axle
9	3256-23	4	Washer-Flat	27	1-543436	2	Washer-Spacer
10	1-323548	2	Linkage-Brake	30	109-4359	2	Drum And Sheave ASM
11	110-5866	2	Swivel-Brake	31	32128-20	4	Nut-HF
12	1-513959	2	Wingnut-Nylock	32	3296-39	4	Nut-Lock, NI

● Not serviced separately

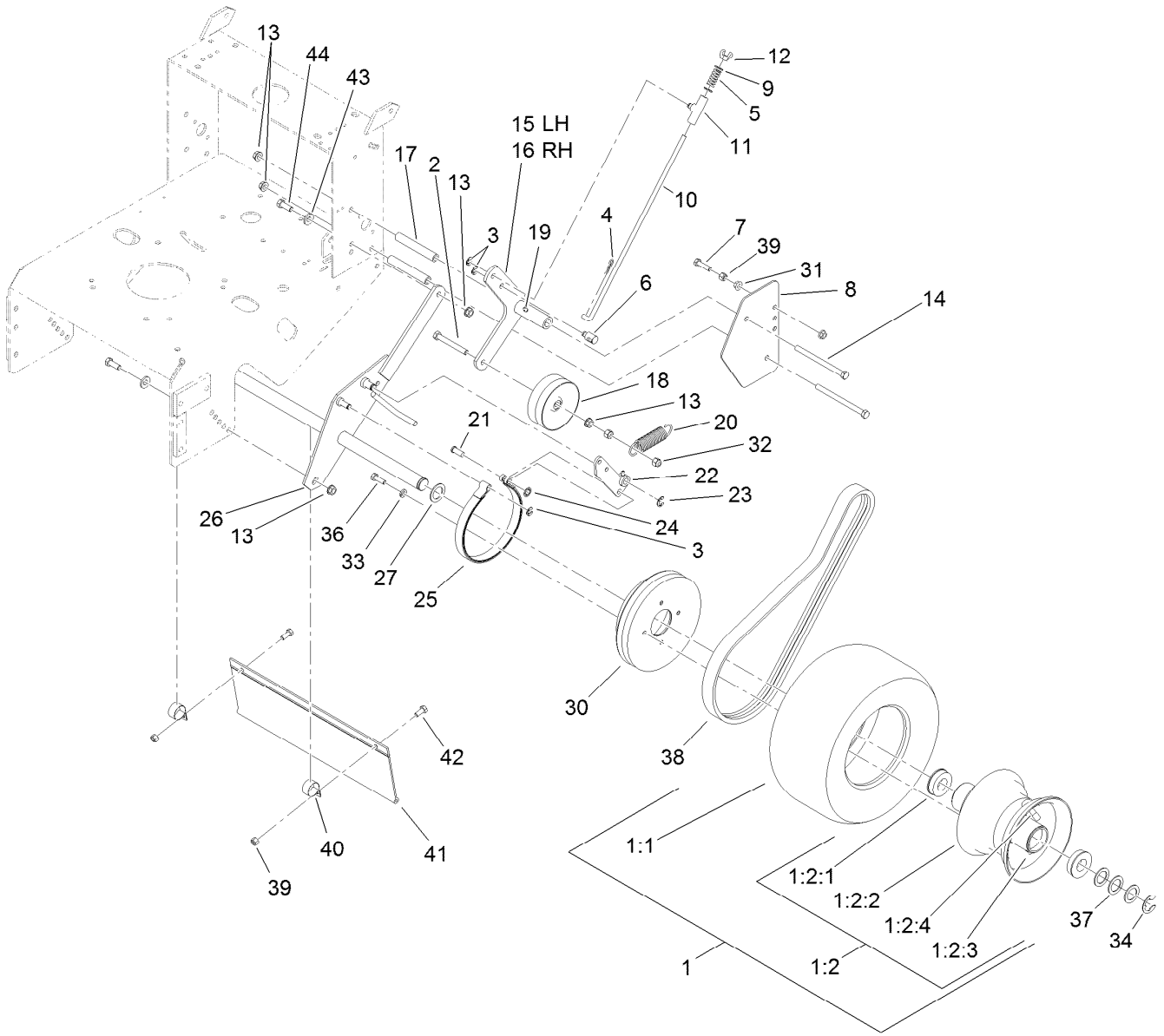

Drive Wheel and Brake Assembly (continued)

Ref.	Part Number	Qty.	Description
33	1-805005	8	Washer-Lock
34	1-808519	2	Ring-Snap
36	322-5	8	Screw-HH
37	1-523157	6	Washer-Spacer
38	1-323631	2	V-Belt
39	3296-29	4	Nut-Lock, NI

Ref.	Part Number	Qty.	Description
40	2412-104	2	Clamp-R
41	98-3259	1	Shield-Trailing
42	322-3	2	Screw-HH
43	98-5975	4	Washer-Belleville
44	323-6	4	Screw-HH

● Not serviced separately

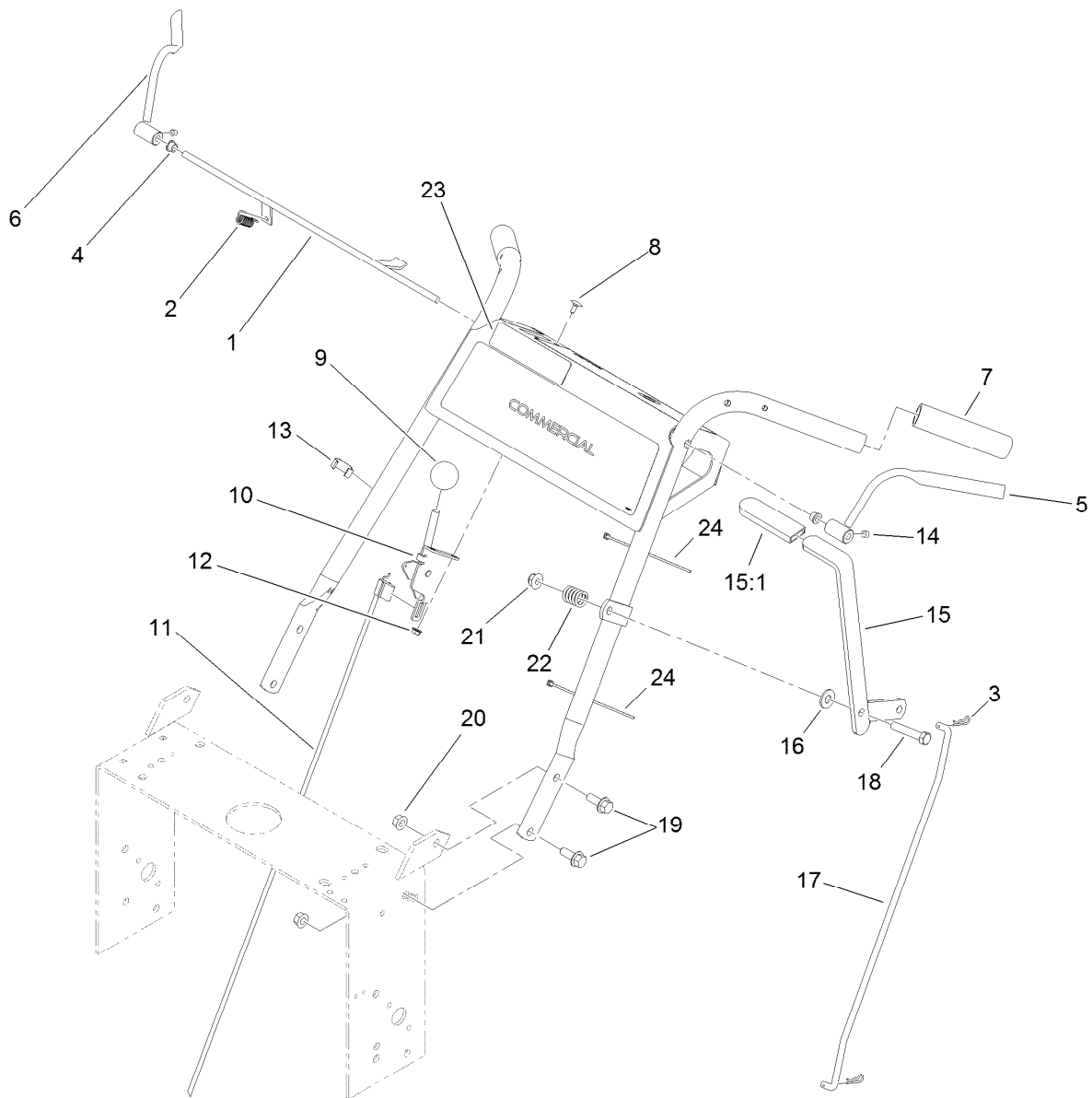

Handle Control Assembly

<i>Ref.</i>	<i>Part Number</i>	<i>Qty.</i>	<i>Description</i>	<i>Ref.</i>	<i>Part Number</i>	<i>Qty.</i>	<i>Description</i>
1	106-2717-03	1	Rod-CONTROL, Operator Presence	12	32128-17	2	Nut-Lock, Flange
2	1-303363	1	Spring-Extension	13	1-303088	1	Clip-Cable
3	1-806003	2	Pin-Cotter, Hair	14	1-803322	2	Screw-Set
4	1-303365	2	Bushing-Nylon	15	116-6331	1	Lever ASM
5	106-5485	1	LH Operator Presence Control Lever ASM	15:1	1-303020	1	Grip-Lever
6	106-5486	1	RH Operator Presence Control Lever ASM	16	3256-4	1	Washer-Flat
7	104-9838	2	Grip-Foam	17	1-323298	1	Linkage-Blade, Upper
8	1-807513	2	Bolt-CARR	18	323-10	1	Screw-HH
9	1-603175	1	Knob-Ball	19	32128-21	4	Nut-HF
10	110-5547	1	Lever-Control	20	3234-11	4	Screw-HHF
11	119-1823	1	Cable-Control, Throttle	21	104-8301	1	Nut-Flange, NI
				22	1-303160	1	Spring-Compression
				23	117-2718	1	Decal-Arrester, Spark
				24	1-303287	2	Tie-Cable

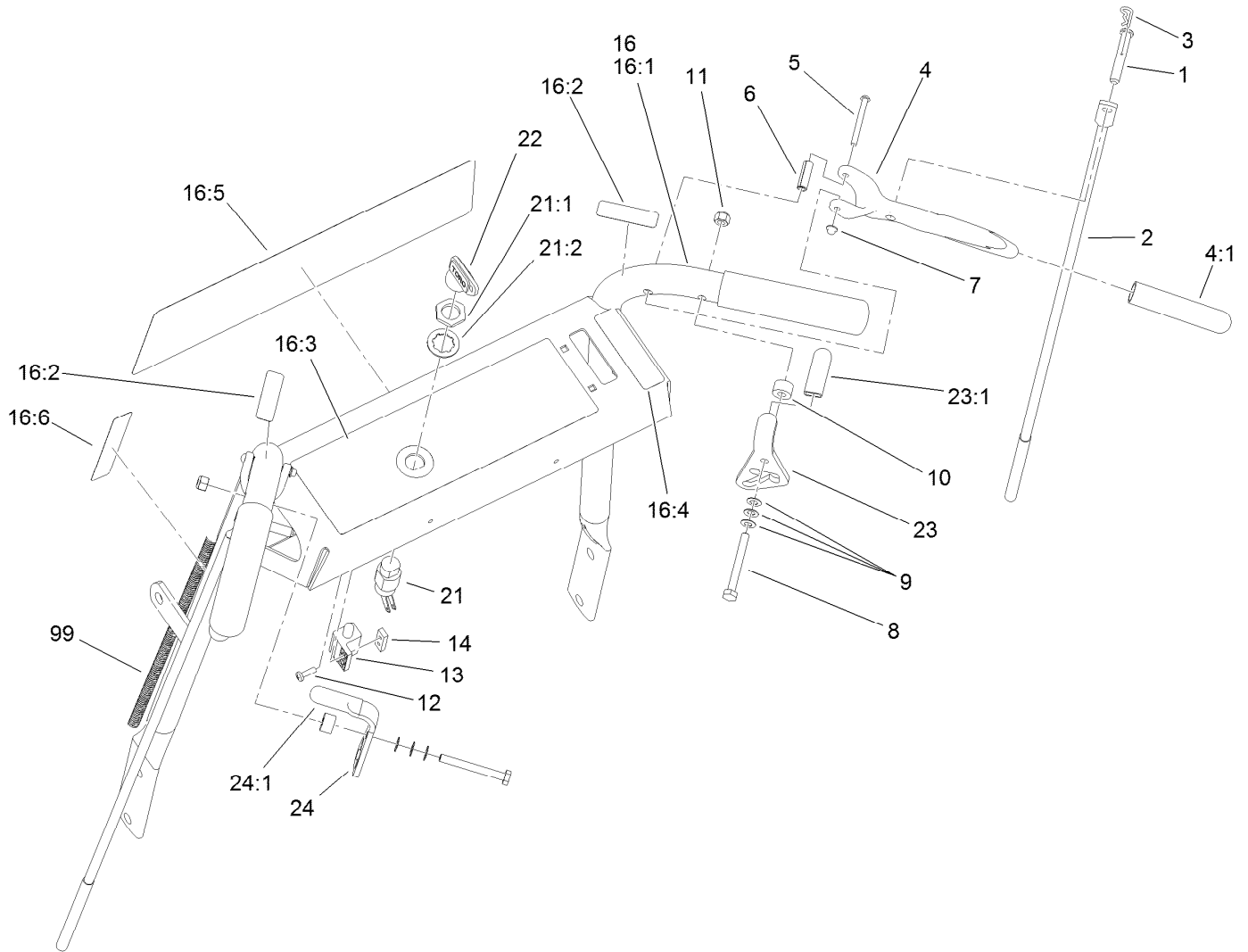

Handle Assembly

Ref.	Part Number	Qty.	Description	Ref.	Part Number	Qty.	Description
1	1-808286	2	Pin-Clevis	16:1		1	Pistol Grip Handle ASM ●
2	1-323359	2	Linkage-Wheel, Drive	16:2	105-4111	2	Decal-Lock, Neutral
3	1-806003	2	Pin-Cotter, Hair	16:3	106-2737	1	Decal-Warning
4	1-302006	2	Drive Lever ASM	16:4	106-2733	1	Decal-Throttle
4:1	1-303021	1	Grip-Lever, Drive	16:5	110-6917	1	Decal
5	1-808250	2	Pin-Lever, Drive	16:6	95-5537	1	Decal-Engage, Deck
6	1-806340	2	Pin-Roll	21	29-5560	1	Switch-On / Off
7	1-803001	2	Nut	21:1	218-461	1	Nut-HH
8	321-18	2	Screw-HH	21:2	3254-5	1	Washer-Tooth, Internal
9	1-303435	6	Washer-Spring	22	63-8360	1	Key-Ignition
10	1-323549	2	Spacer	23	1-324280	1	RH Thumb Latch ASM
11	3296-42	2	Nut-Lock, NI	23:1	1-303019	1	Grip-Latch
12	3290-500	2	Screw-PPH	24	1-324279	1	LH Thumb Latch ASM
13	1-513051	1	Switch-Open, Normally	24:1	1-303019	1	Grip-Latch
14	1-633181	1	Plate-Tapped	99	116-2661	1	Harness-Wire
16	119-3638	1	Handle ASM				

● Not serviced separately

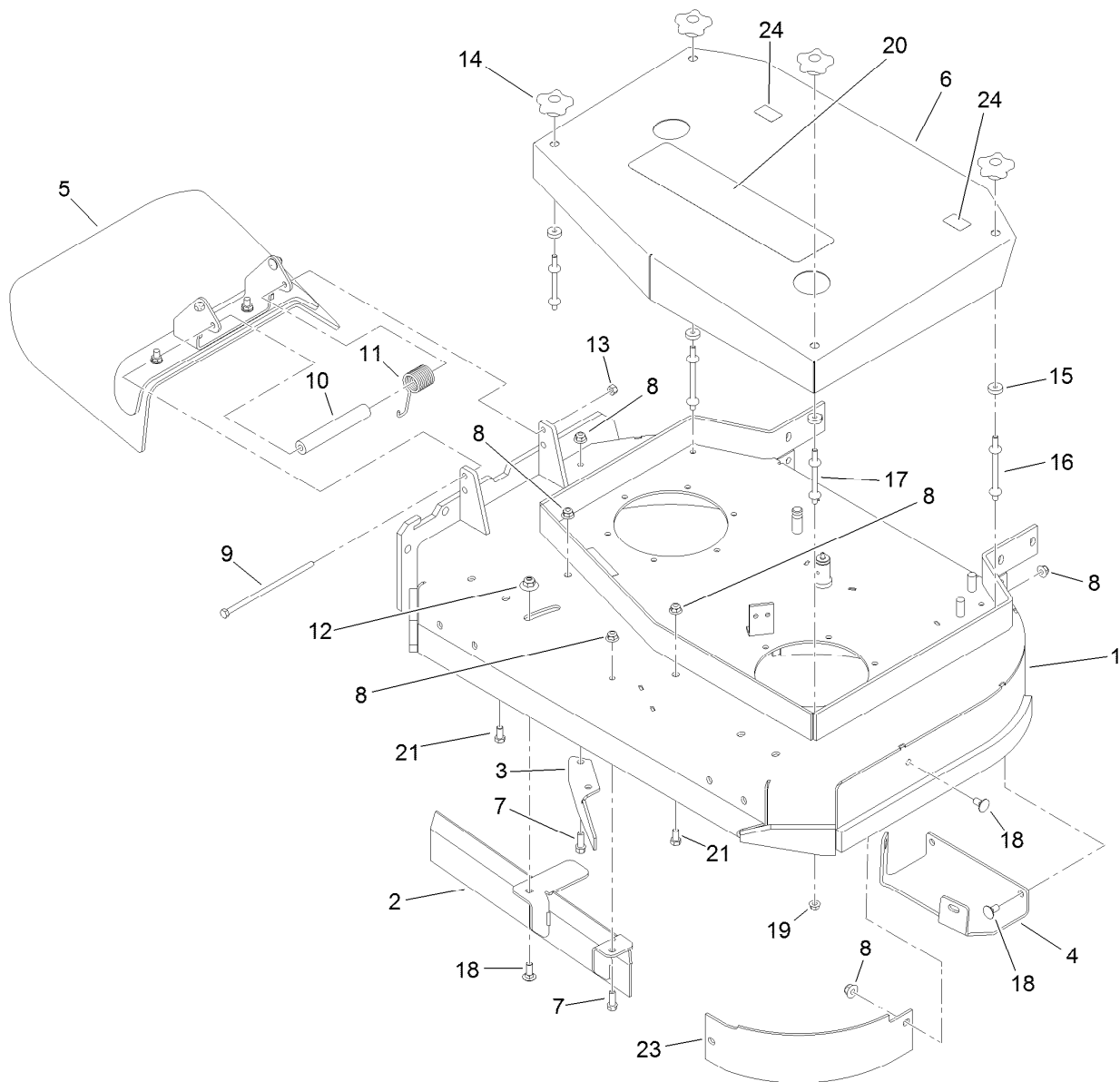

Deck Assembly

<i>Ref.</i>	<i>Part Number</i>	<i>Qty.</i>	<i>Description</i>	<i>Ref.</i>	<i>Part Number</i>	<i>Qty.</i>	<i>Description</i>
1	110-4907	1	Deck ASM	13	3296-47	1	Nut-Lock, NI
2	121-1777-03	1	Baffle	14	106-4161	4	Knob-Handle
3	110-0754-01	1	Baffle-Discharge	15	1-323417	4	Washer
4	110-2037-01	1	Plate-Skid	16	1-303536	2	Stud-Shield, Belt (Long)
5	119-6530	1	Deflector ASM	17	1-303537	2	Stud-Shield, Belt (Short)
6	110-2036-01	1	Cover-Deck	18	3231-2	6	Bolt-CARR
7	92-1624	3	Screw-HWH	19	32128-20	4	Nut-HF
8	104-8301	10	Nut-Flange, NI	20	112-9710	1	Decal
9	322-50	1	Screw-HH	21	323-4	2	Screw-HH
10	105-4622	1	Spacer	23	110-6903-03	1	Baffle-Front, LH
11	108-4052	1	Spring-Torsion	24	103-2076	2	Decal-Caution
12	109-6658	1	Nut-Flange, NI				

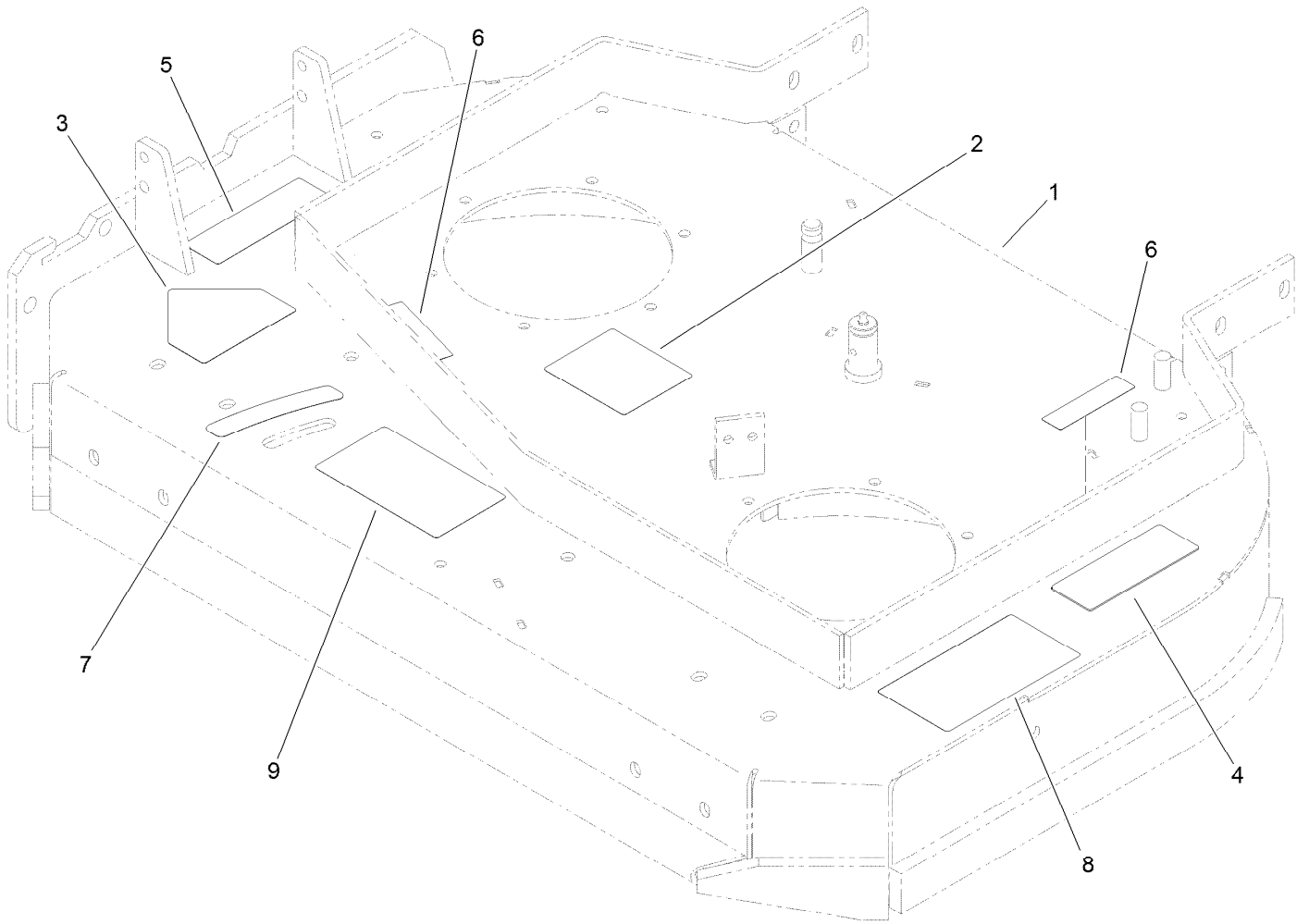

Deck Decal Assembly No. 110-4907

<i>Ref.</i>	<i>Part Number</i>	<i>Qty.</i>	<i>Description</i>
1		1	36 Inch Deck ASM ●
2	98-3296	1	Decal-Routing, Belt
3	1-403005	1	Decal-Danger
4	98-5130	1	Decal-Torque, Bolt
5	104-8569	1	Decal-Warning
6	98-5954	2	Decal-Missing Cover
7	110-2067	1	Decal-Setting, Baffle
8	66-1340	1	Decal-Danger, Thrown Object
9	110-2068	1	Decal-Adjustment, Baffle

● Not serviced separately

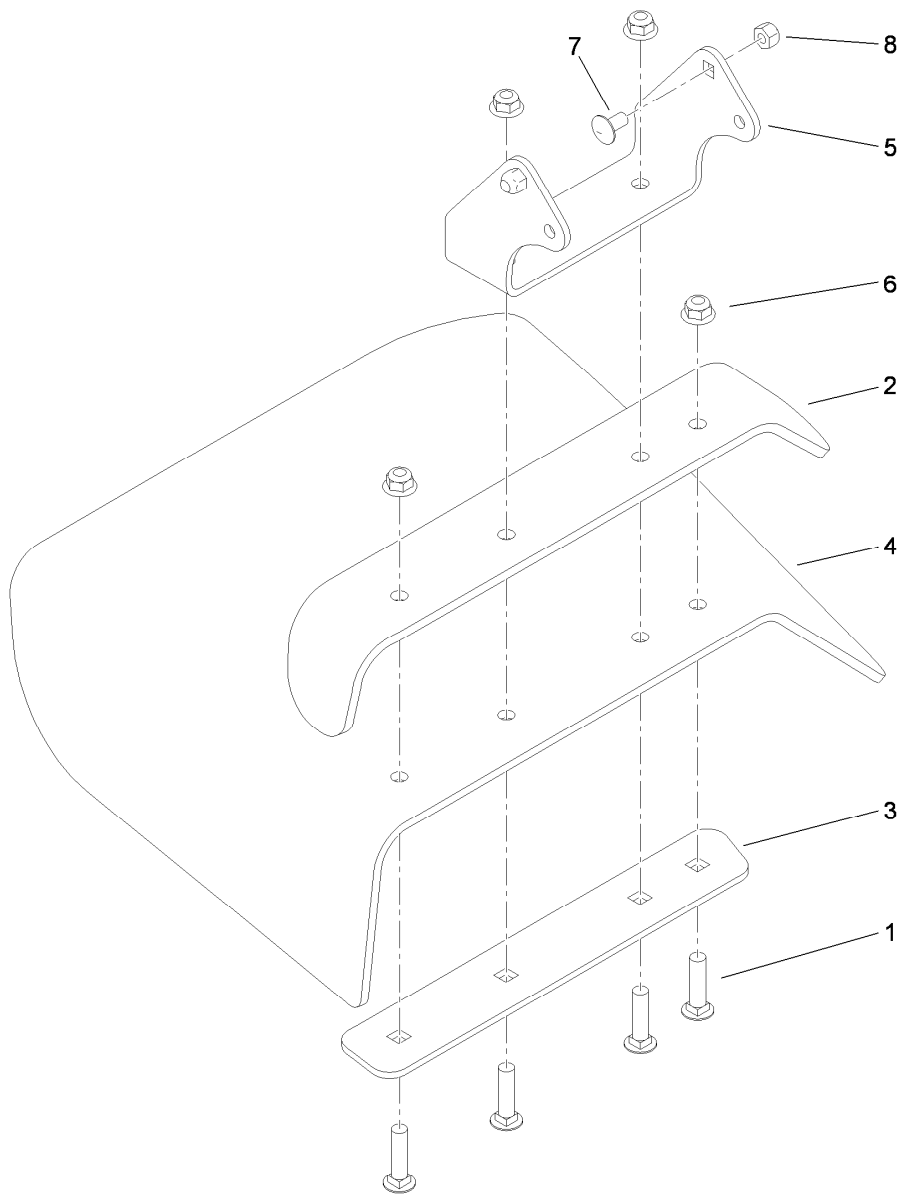

Deflector Assembly No. 119-6530

<i>Ref.</i>	<i>Part Number</i>	<i>Qty.</i>	<i>Description</i>
1	3231-4	4	Screw-CARR
2	110-0792-01	1	Deflector
3	110-0793-03	1	Strap-Discharge
4	110-0791	1	Deflector-Rubber
5	119-6532-01	1	Bracket-Mounting, Deflector
6	104-8301	4	Nut-Flange, NI
7	3230-18	2	Screw-CARR
8	3296-29	2	Nut-Lock, NI

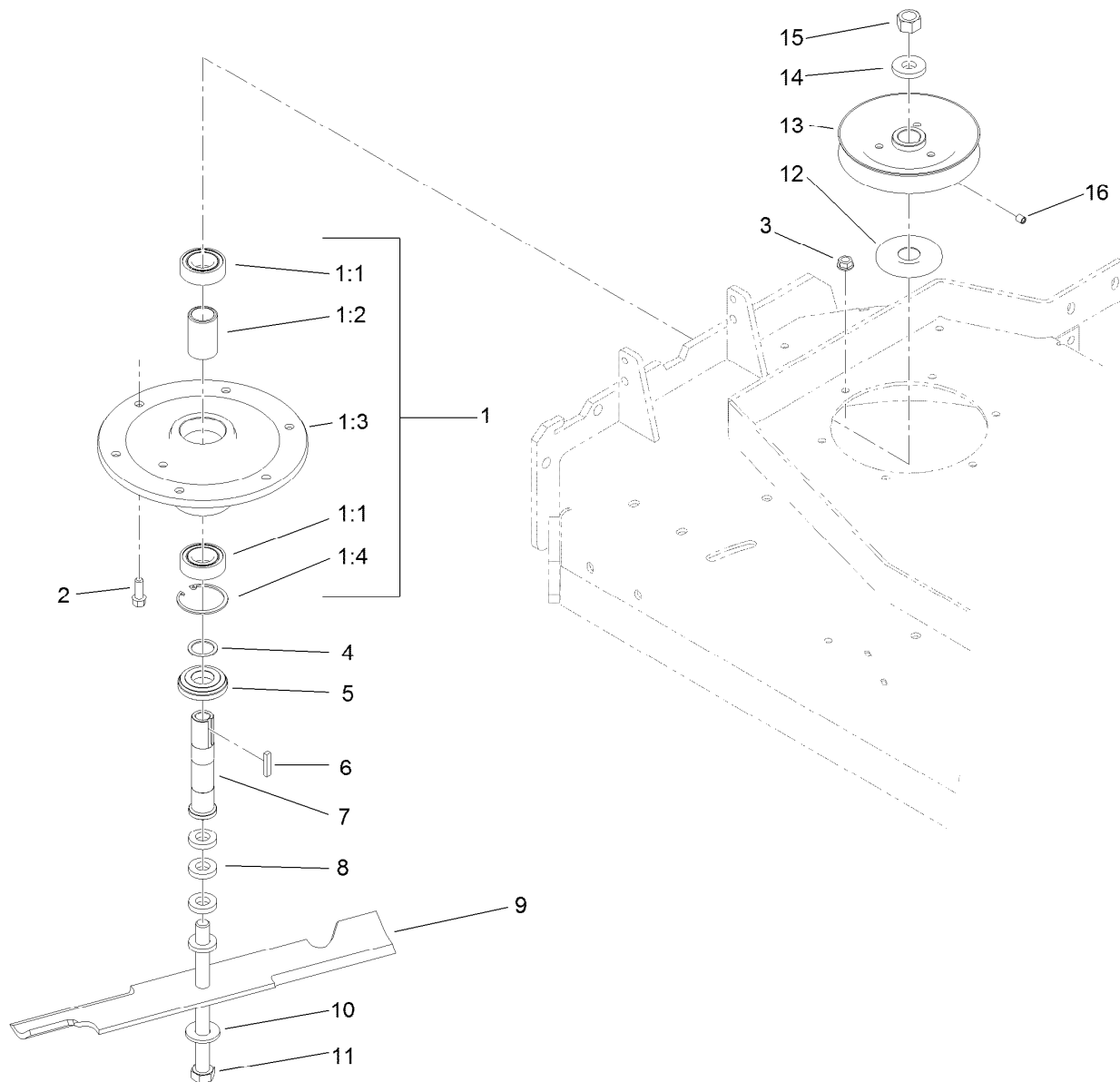

Sheave, Spindle and Blade Assembly

Ref.	Part Number	Qty.	Description	Ref.	Part Number	Qty.	Description
1	108-6697	2	Spindle Housing ASM	7	1-323529	2	Tube-Spindle, Short
1:1	119-7857	2	Bearing-Ball, 1 Inch	8	1-323539	8	Spacer
1:2	110-2116	1	Spacer-Bearing	9	105-7781-03	2	Blade-18In, Hi Flow
1:3	108-6694	1	Housing-Spindle	10	1-513208	2	Washer-Spring
1:4	32120-8	1	Ring-Snap	11	1-800861	2	Screw-Cap, HH
2	92-1624	12	Screw-HWH	12	103-1330	2	Guard-Bearing, Top
3	104-8301	12	Nut-Flange, NI	13	1-403183	2	Sheave
4	110-4888	2	Washer-Spacer	14	1-323339	2	Washer-Retainer, Sheave
5	103-2535	2	Spacer-Guard, Bottom	15	3219-6	2	Nut-Hex
6	1-807267	2	Key	16	3246-18	2	Setscrew

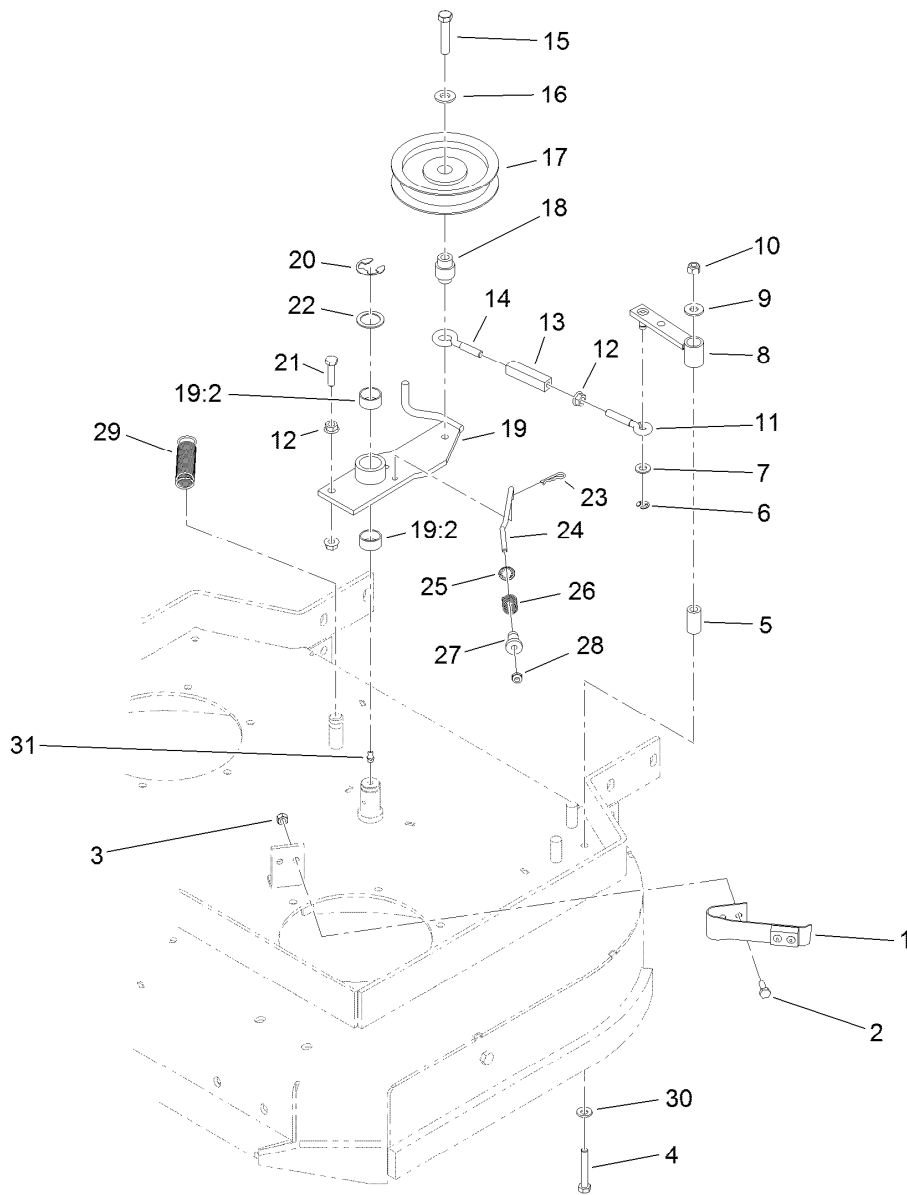

Idler Assembly

Ref.	Part Number	Qty.	Description	Ref.	Part Number	Qty.	Description
1	1-324372	1	Pad And Spring ASM	18	1-303434	1	Bushing-Engagement
2	321-4	2	Screw-HH	19	103-3600	1	Idler Arm ASM
3	3296-42	2	Nut-Lock, NI	19:2	1-323729	2	Sleeve-Bearing
4	322-10	1	Screw-HH	20	32151-103	1	Ring-Retaining, EXT
5	1-403179	1	Tube-Pivot	21	116-3515	1	Screw-HH, Special
6	32120-35	1	Ring-Retaining, EXT	22	1-303352	1	Washer-Spindle
7	3256-23	1	Washer-Flat	23	1-806003	1	Pin-Cotter, Hair
8	1-322235	1	Arm-Assist	24	1-323715	1	Rod-Brake
9	3256-3	1	Washer-Flat	25	1-323748	1	Ring-Push On
10	3296-29	1	Nut-Lock, NI	26	1-323747	1	Spring-Compression
11	1-303238	1	Eyebolt-Thread, RH	27	1-323746	1	Spacer-Flanged
12	32128-20	3	Nut-HF	28	3296-56	1	Nut-Lock, NI
13	1-303236	1	Body-Turnbuckle	29	1-323071	1	Spring-Extension
14	1-303348	1	Eyebolt-Thread, LH	30	1-303334	1	Washer-Spring
15	702809	1	Screw-HH	31	302-40	1	Fitting-Grease
16	98-5975	1	Washer-Belleville				
17	116-3626	1	Pulley-Idler				

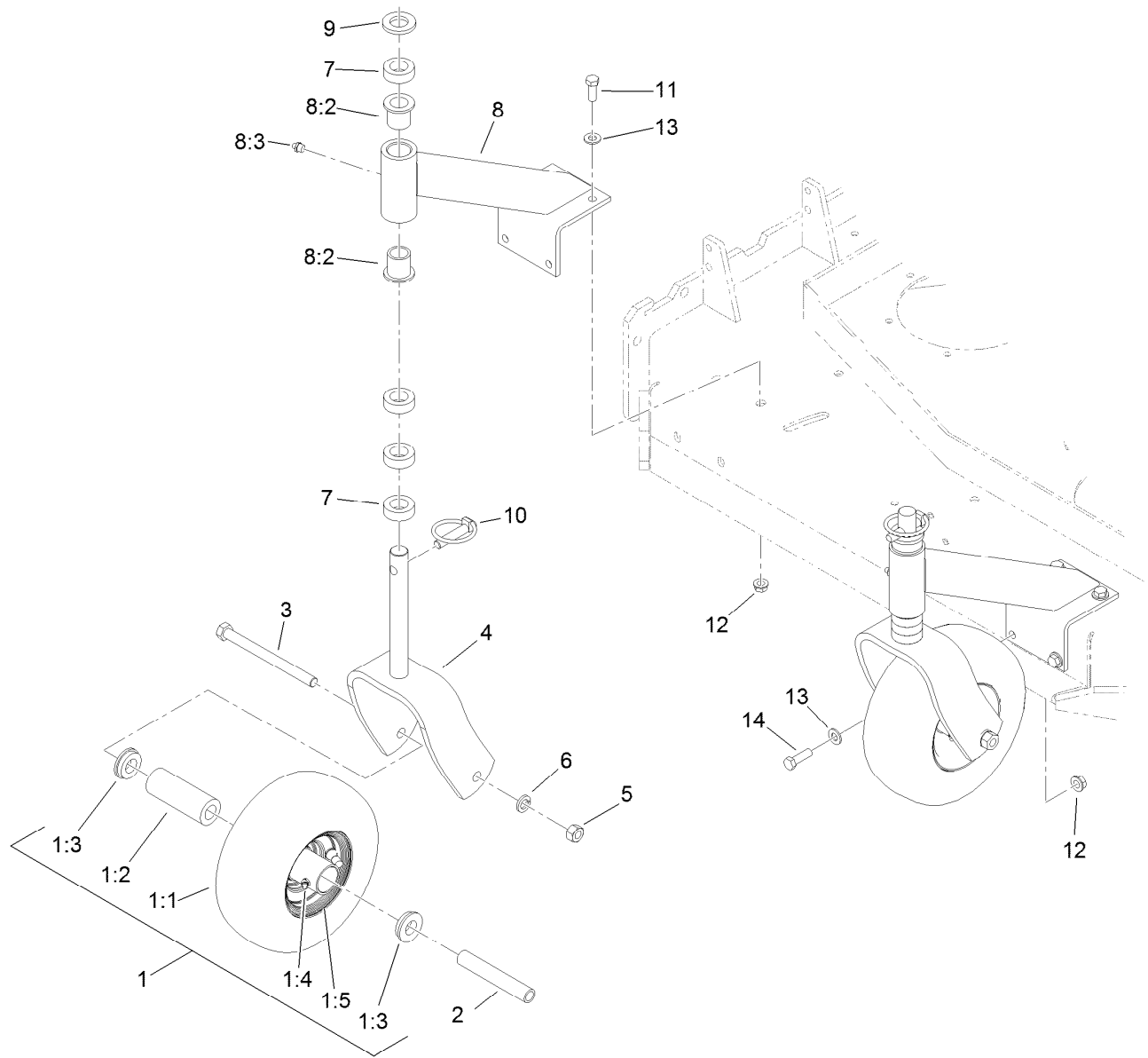

Caster Assembly

Ref.	Part Number	Qty.	Description
1	130-4557	2	Wheel And Tire ASM
1:1		1	Tire ●
1:2	1-513809	1	Bearing
1:3	1-513810	2	Bushing
1:4	302-61	1	Fitting-Grease
1:5		1	Wheel ●
2	1-513547	2	Spacer
3	325-20	2	Screw-HH
4	116-7942-01	2	Fork-Caster
5	3217-9	2	Nut-HH
6	3253-7	2	Washer-Lock

Ref.	Part Number	Qty.	Description
7	1-303314	8	Spacer-Caster
8	110-2130	2	Support ASM
8:2	1-303514	2	Bearing-Flanged
8:3	302-52	1	Fitting-Grease
9	1-513338	2	Washer-Flat
10	1-809020	2	Pin
11	323-6	7	Screw-HH
12	104-8301	8	Nut-Flange, NI
13	3256-24	8	Washer-Flat
14	323-7	1	Screw-HH

● Not serviced separately

Attachments and Accessories

For 39634 Commercial Walk-Behind Mower Fixed Deck, Pistol Grip, Gear Drive with 36in TURBO FORCE Cutting Unit

Product Name	Model/Part
Blade-Recycler, 18in.....	105-7779-03
Blade-Med Flow, 18in	105-7794-03
Blade-Low Flow, 18in.....	105-7795-03
Blade-Atomic, 18in	105-7796-03
Blade-Hi Flow, 18in (6 Pack).....	108-1117
Blade-Atomic, 18in (6 Pack)	108-1118
Blade-Lo Flow, 18in (6 Pack)	110-0406
Blade-Recycler, 18in (6 Pack).....	110-0408
Blade-Med Flow, 18in (6 Pack)	110-0409
36in Bagger Enhancement Kit	110-2026
36in Recycler Kit.....	110-2080
Weight Kit	110-2085
Operator-Controlled Discharge Chute Kit	115-4190
Soft Bag (3 Bushel).....	30104
Sulky.....	30109



Count on it.