



**Count on it.**

**Operator's Manual**

**ProCore® SR48, SR54, SR54-S,  
SR70, SR70-S, SR72 and SR75  
Aerators**

Model No. 09930—Serial No. 31400001 and Up

Model No. 09931—Serial No. 31400001 and Up

Model No. 09932—Serial No. 31400001 and Up

Model No. 09933—Serial No. 31400001 and Up

Model No. 09934—Serial No. 31400001 and Up

Model No. 09935—Serial No. 31400001 and Up

Model No. 09936—Serial No. 31400001 and Up



This product complies with all relevant European directives, for details please see the separate product specific Declaration of Conformity (DOC) sheet.

**⚠ WARNING**

**CALIFORNIA  
Proposition 65 Warning**

**This product contains a chemical or chemicals known to the State of California to cause cancer, birth defects, or reproductive harm.**

<b>Model No.</b> _____
<b>Serial No.</b> _____

This manual identifies potential hazards and has safety messages identified by the safety alert symbol (Figure 2), which signals a hazard that may cause serious injury or death if you do not follow the recommended precautions.



**Figure 2**

1. Safety alert symbol

# Introduction

This aerator, which is towed behind a tractor, is intended to be used by professional, hired operators in commercial applications. It is primarily designed for aerating large areas on well-maintained lawns in parks, golf courses, sports fields, and on commercial grounds.

Read this information carefully to learn how to operate and maintain your product properly and to avoid injury and product damage. You are responsible for operating the product properly and safely.

You may contact Toro directly at [www.Toro.com](http://www.Toro.com) for product and accessory information, help finding a dealer, or to register your product.

Whenever you need service, genuine Toro parts, or additional information, contact an Authorized Service Dealer or Toro Customer Service and have the model and serial numbers of your product ready. Figure 1 identifies the location of the model and serial numbers on the product. Write the numbers in the space provided.

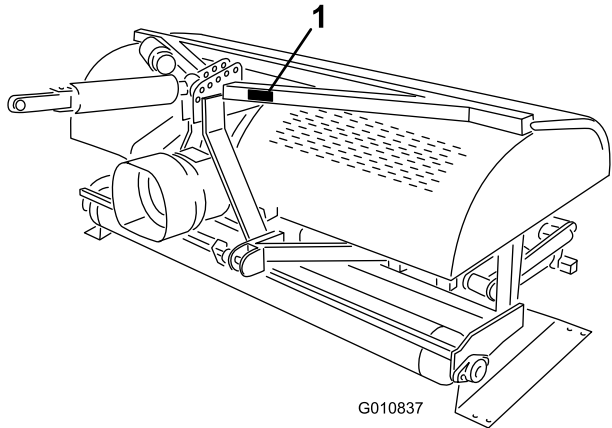

**Figure 1**

1. Model and serial number location

This manual uses 2 other words to highlight information. **Important** calls attention to special mechanical information and **Note** emphasizes general information worthy of special attention.

# Contents

Introduction .....	2
Safety .....	4
Safe Operating Practices .....	4
Safety and Instructional Decals .....	6
Setup .....	8
1 Removing the Aerator from the Crating.....	9
2 Connecting the Lower Link Arms.....	9
3 Connecting the Hydraulic Top Link (Models SR48, SR54, SR70, SR72 and SR75) .....	10
4 Installing the Depth Gauge (Models SR48, SR54, SR70, SR72 and SR75).....	12
5 Connecting the Tractor Upper Link (Models SR54–S and SR70–S).....	13
6 Verifying the Hydraulic Top Link Set Up .....	13
7 Checking the PTO Angle .....	14
8 Fitting the PTO shaft .....	14
9 Installing the PTO Shield .....	16
10 Connecting the PTO Shaft .....	16
11 Adjusting the Sway Links.....	18
12 Leveling the Aerator Side-to-Side.....	18
13 Installing the Tines .....	18
14 Setting the Tine Depth (Models SR54–S and SR70–S) .....	19
15 Installing the Rear Guard.....	19
16 Installing the Latch Lock .....	20
17 Removing the Storage Stands(Models SR54 and SR70 ) .....	21
18 Removing the Storage Stands(Models SR48 and SR72).....	21
Product Overview .....	23
Specifications .....	23
Attachments/Accessories.....	23
Operation .....	24
Tractor Controls.....	24
Principles of Operation .....	24
Tractor PTO Speed .....	24
Training Period .....	24
Before Aerating.....	24
Aerating Procedures .....	24
Operating Tips.....	25
Subsoil Cultivation .....	25
Hard Ground.....	26
Longer/Larger Tines (10 inches or more.....	26
Multi Row Adapter Heads .....	26
Root Zone Lifting .....	26
Using the Hood Prop RodsModel SR75 only .....	26
Adjusting the Tine Angle.....	26
Adjusting the Tine Depth(Models SR54–S and SR70–S) .....	28
Adjusting the Head Return Springs .....	28
Transport Operation.....	29
Inspection and Cleanup after Use.....	29
Maintenance .....	30
Recommended Maintenance Schedule(s) .....	30

Lifting the Machine .....	30
Greasing the Bearings .....	31
Checking the Gearbox Oil .....	31
Changing the Gearbox Oil.....	32
Inspecting/Adjusting the Drive Chain.....	32
Adjusting the PTO Clutch .....	33
Fastener Torque Specifications .....	33
Checking the Springs .....	34
Adjusting the Hole Spacing.....	34
Removing the Aerator from the Tractor .....	34
Trouble Shooting .....	35
Storage .....	36

# Safety

Improper use or maintenance by the operator or owner can result in injury. To reduce the potential for injury, comply with these safety instructions and always pay attention to the safety alert symbol, which means CAUTION, WARNING, or DANGER - "personal safety instruction." Failure to comply with the instruction may result in personal injury or death.

## Safe Operating Practices

### Before Operating

- Owners of this Aerator must give operators and employees full operation and safety instructions before allowing them to operate this machine and at least annually thereafter. An operator who has not read and fully understood all operating and safety instructions is not qualified to operate this machine. Become familiar with all controls and know how to stop quickly.
- Do not allow children to operate the machine. Do not allow adults to operate the machine without proper instruction.
- Remove all debris or other objects that might interfere with operation. Keep all bystanders away from the work area.
- Locate and mark all under ground obstructions such as irrigation components, electrical or telephone lines.
- Make sure tractor is in neutral and parking brake applied before starting. Refer to Tractor Operator's Manual for safe starting procedures.
- Ensure that your tractor is suitable for use with an implement of this weight by checking with your tractor supplier or manufacturer.
- Mounting the aerator to the rear of the tractor will decrease the weight on the tractor front axle. To assure adequate steering control and stability it may be necessary to add ballast to the front of the tractor. Refer to Tractor Operator's Manual for ballast requirements.
- Keep all shields and safety devices in place. If a shield, safety device or decal is damaged, repair or replace it before operation is commenced. Also tighten any loose nuts, bolts and screws to ensure machine is in safe operating condition.
- Do not operate machine while wearing sandals, tennis shoes, sneakers or shorts. Also, do not wear loose fitting clothing which could get caught in moving parts. Always wear long pants and substantial shoes. Wearing safety glasses, safety shoes, hearing protection and a helmet is advisable and may be required by some local ordinances and insurance regulations.

### While Operating

- Never operate the tractor in reverse when the aerator is lowered.
- Keep all bystanders and pets away from the work area.
- Using the machine demands attention, and to prevent loss of control:
  - Use only in daylight or when there is adequate artificial light.
  - Watch for holes or other hidden hazards.
  - Do not operate the machine close to a sand trap, ditch, creek or other hazard.
  - Reduce speed on side hills and before making sharp turns to prevent tipping or loss of control.
  - Look behind the aerator before backing up.
- If the tines strike a solid object or the machine vibrates abnormally, disengage the PTO, set the parking brake and shut the engine off. Remove key from ignition switch. Check aerator and traction unit for damage. Repair any damage before restarting the engine and operating the tines. Be sure tines are in good condition and all bolts are tight.
- Before leaving machine unattended, disengage power to aerator, lower aerator onto storage stands and set parking brake. Stop engine.
- Never dismount while tractor is in motion. Never get on or off tractor while engine is running and PTO drive shaft is engaged. Never step over PTO shaft to reach other side of aerator - walk around the machine.
- When lifting the aerator, disengage the PTO when the roller is approximately 5 inches from the ground.
- Do not operate this machine without the roller on the ground. **Never operate with the machine in the raised position.**
- Park the aerator on a hard, level surface, install the aerator storage stands before disconnecting from tractor.
- If it is necessary to probe below the soil surface, use a non conductive material to prevent electrical shock in case electrical wires are present.
- Always lower the aerator to the ground before leaving the tractor unattended. Never leave the aerator in the raised position when it is unattended.

### Transporting

- The aerator is heavy. When attached to a tractor and in the raised position, its weight will affect stability, braking and steering. Exercise caution when transporting between working areas.
- Always maintain proper tractor tire pressure.
- Be sure you are in compliance with all regulations before transporting equipment on the public roads and highways. Make sure all required reflectors and lights are in place and are clean and visible by overtaking and oncoming traffic.

- Never allow passengers to ride on the machine during transport.
- Reduce speed on rough roads and surfaces
- Independent wheel brakes should always be locked together when transporting.

replacement parts and accessories could void the warranty of The Toro Company.

## PTO Shaft

- For all PTO shaft steel parts (tubes, bearings, joints etc.) disassembly or repairs, it is highly advisable to contact your local Toro distributor. Removal of components for repairs and reassembly may damage some parts if not performed with special tools by trained technicians.
- The PTO shaft must not be used without the guards supplied, with partial protection or with damaged guards. On CE machines, operation is prohibited without the special anti-rotation chains correctly installed, so as to permit the maximum angle of the PTO shaft without breaking the chains.
- Friction clutches may become hot during use. **Do not touch.** To avoid the risk of fire, keep the area around the clutch free of flammable material and avoid prolonged slipping of the clutch.

## Storage Safety

- Store the aerator on the storage stands positioned on a firm level surface.
- Store the aerator away from areas of human activity.
- **Do not** allow children to play on or around the stored machine.
- Make sure the aerator is positioned on firm and solid ground so it does not sink or tip over.

## Maintenance

- Before making adjustments or performing maintenance on the aerator, switch off the engine, stop the PTO and apply the parking brake before dismounting from the tractor. Be sure the aerator is on the ground or lowered onto the safety stands.
- Support the machine with the blocks, jacks or on storage stands when working beneath it. **Never rely on the tractor's hydraulics to support the machine.**
- Place all controls in neutral, stop the engine, apply parking brake and wait for all moving parts to stop before servicing, maintaining, adjusting or unblocking the aerator.
- Be sure the machine is in safe operating condition by keeping nuts, bolts and screws tight. Check the tine mounting bolts daily to be sure they are tightened to specification.
- Do not check or adjust the chain tension when the tractor engine is running.
- Be sure all guards are replaced and the hood is secured shut after maintaining or adjusting the machine.
- Perform only those maintenance instructions described in this manual. If major repairs are ever needed or assistance is desired, contact an Authorized Toro Distributor. To ensure optimum performance and safety, always purchase genuine Toro replacement parts and accessories to keep the Toro all Toro. Never use "will-fit" replacement parts and accessories made by other manufacturers. Look for the Toro logo to ensure genuineness. Using unapproved

# Safety and Instructional Decals



Safety decals and instructions are easily visible to the operator and are located near any area of potential danger. Replace any decal that is damaged or lost.

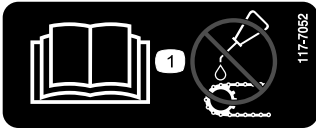

117-7052

1. Read the *Operator's Manual*, do not oil the chain drive.

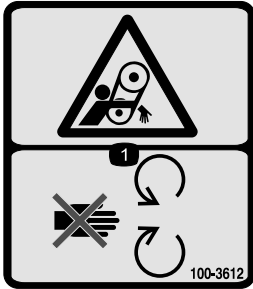

100-3612

1. Entanglement hazard—stay away from moving parts, keep all guards and shields in place.



110-4668

1. Entanglement hazard, shaft—stay away from moving parts.
2. PTO speed and input direction.
3. Use clip to secure lash cable when not in use. Use lash cable to support the power take-off when the machine is disconnected from tractor.

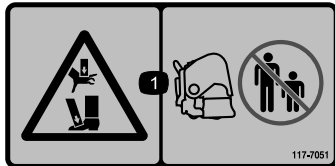

117-7051

1. Crushing hazard of hand or foot—keep bystanders a safe distance from the machine.



92-1581



92-1582

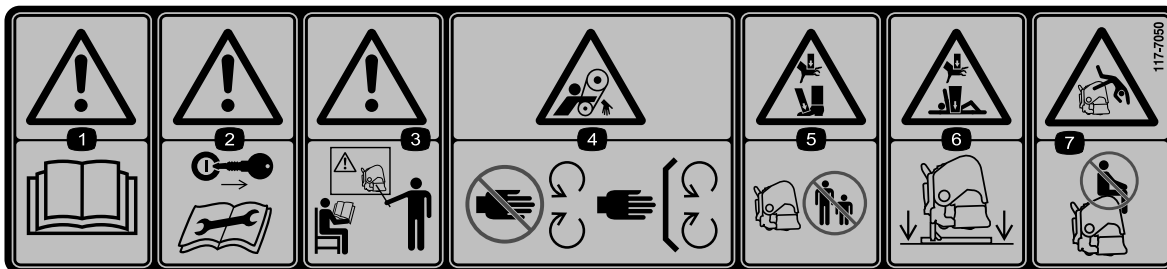

117-7050

1. Warning—read the *Operator's Manual*.
2. Warning—remove the ignition key and read the instructions before servicing or performing maintenance.
3. Warning—do not operate this machine unless you are trained.
4. Entanglement hazard, belt—stay away from moving parts, keep all guards in place.
5. Crushing hazard of hand or foot—keep bystanders a safe distance from the machine.
6. Crushing hazard of hand and body—support machine on stand when not in use.
7. Falling hazard—do not carry passengers.

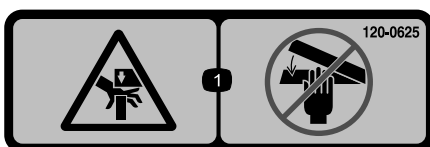

120-0625

1. Pinch point, hand—keep hands away.

# Setup

## Loose Parts

Use the chart below to verify that all parts have been shipped.

Procedure	Description	Qty.	Use
<b>1</b>	No parts required	–	Remove the aerator from the crating
<b>2</b>	Hitch pin Lynch pin	2 2	Connect lower link arms (Hitch pins and lynch pins are shipped installed on the SR54 and SR54-S Aerators)
<b>3</b>	Hydraulic top link Hydraulic hose, 3–1/2 feet Hydraulic hose, 2–1/2 feet Extension bracket Rotational bracket Hose quick couplings	1 1 1 2 1 2	Connect Hydraulic Top Link (Models SR48, SR54, SR70, SR72 and SR75)
<b>4</b>	Depth gauge Slide block Machine screw, #10 x 1/2 inch Screw, 1/4 x 2–1/2 inch Tube clamp Weld plate Depth decal	1 1 2 2 1 1 1	Install the depth gauge
<b>5</b>	Spring loaded top link Link pin Lynch pin	1 3 3	Connect Upper Link (Models SR54–S and SR70–S)
<b>6</b>	No parts required	–	Verify the top link set up
<b>7</b>	No parts required	–	Checking the PTO angle
<b>8</b>	PTO shaft	1	Fitting the PTO shaft
<b>9</b>	PTO Shield	1	Install the PTO Shield
<b>10</b>	Pin (supplied with PTO shaft) Nut (supplied with PTO shaft)	1 1	Connect PTO Shaft
<b>11</b>	No parts required	–	Adjusting Sway Links
<b>12</b>	Level (not supplied)	1	Level Aerator Side-to-Side
<b>13</b>	Tines	A/R	Install the Tines
<b>14</b>	No parts required	–	Set the tine depth
<b>15</b>	Rear guard Screw, 3/8 x 3–1/4 inch Flat washer, .438 x 1.00 inch Lock nut End cap	1 4 12 4 2	Install the rear guard



Procedure	Description	Qty.	Use
<b>16</b>	Lock plate	2	Install the latch lock
	Tap bolt	2	
	Retaining ring	2	
<b>17</b>	No parts required	–	Remove Storage Stands
<b>18</b>	No parts required	–	Remove Storage Stands

## Media and Additional Parts

Description	Qty.	Use
Operator's Manual	1	Read before operating the aerator
Parts Catalog	1	Use to reference part numbers
Spring Wires - SR48	4	Replacement spring wires
Spring Wires - SR48	2	Replacement spring wires
Spring Wires - SR54 & SR54-S	6	Replacement spring wires
Spring Wires - SR70 & SR70-S	8	Replacement spring wires
Spring Wires - SR72	4	Replacement spring wires
Spring Wires - SR72	2	Replacement spring wires
Spring Wires - SR75	4	Replacement spring wires
Spring Wires - SR75	2	Replacement spring wires
Operator training materials	1	View before operating the aerator
PTO Operators Manual	1	Read before operating the aerator

# 1

## Removing the Aerator from the Crating

### No Parts Required

#### Procedure

1. Remove the aerator from the crating.
2. Remove the bolts securing the aerator storage stands to the shipping pallet and remove the aerator from the pallet.
3. Remove the storage stands from the aerator. Retain them for storage use.

**Note:** The SR54-S and the SR70-S do not have shipping stands.

4. Place the aerator on a flat, level surface with the front roller on the ground and a 2 x 4 positioned under the heads.

# 2

## Connecting the Lower Link Arms

### Parts needed for this procedure:

2	Hitch pin
2	Lynch pin

#### Procedure

1. Back the tractor squarely up to the aerator until the lower link arms are aligned with the mounting brackets.

**Note:** The aerator gear box shaft should be in line with the tractor PTO shaft (centered on the tractor). If they are not in line, adjust the lower link arms, from side to side until the shafts are aligned.

2. Make sure the PTO is disengaged.

- Engage the parking brake, STOP the engine and remove the key from the ignition. Wait for the engine and all moving parts to STOP before leaving the Operator's seat on the tractor.

**Note:** For maximum ground clearance, the hitch pins should be secured in the aerator lower mounting bracket holes, when so equipped. To determine when to use the upper mounting holes, refer to Connecting the PTO Shaft.

#### SR54 and SR54-S Aerators only

**Note:** The hitch pins and lynch pins are shipped installed on the SR54 and SR54-S Aerators.

- Secure the lower link arms to the aerator mounting pins with lynch pins (Figure 3).

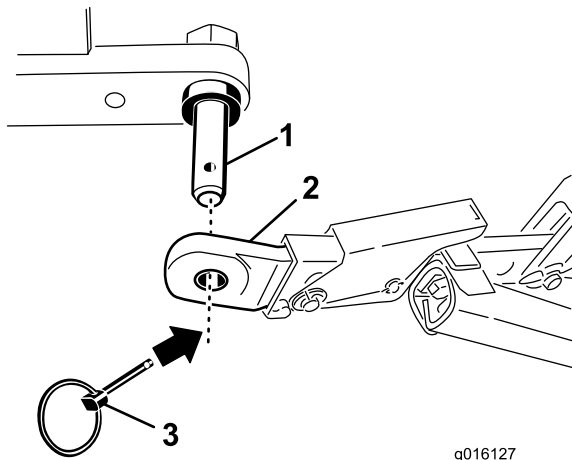
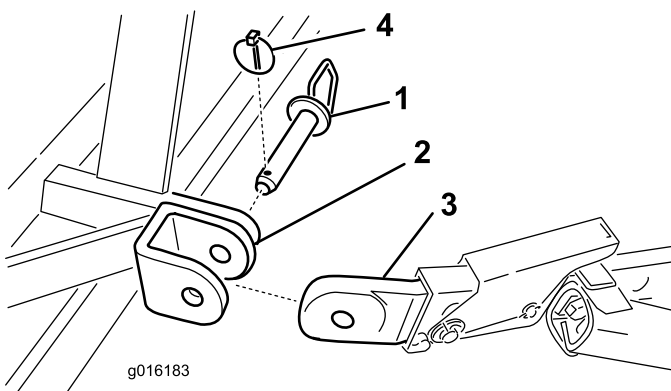

**Figure 3**

- Aerator mounting pin
- Lower link
- Lynch pin

#### SR48, SR70, SR70-S, SR72 and SR75 Aerators only

- Secure the lower link arms to the aerator mounting brackets with hitch pins and lynch pins (Figure 4).



**Figure 4**

- Hitch pin
- Aerator mounting bracket
- Lower link
- Lynch pin

# 3

## Connecting the Hydraulic Top Link (Models SR48, SR54, SR70, SR72 and SR75)

### Parts needed for this procedure:

1	Hydraulic top link
1	Hydraulic hose, 3-1/2 feet
1	Hydraulic hose, 2-1/2 feet
2	Extension bracket
1	Rotational bracket
2	Hose quick couplings

### Procedure

**Note:** Make sure the supplied couplings are correct for the tractor. If not, it will be necessary to contact the tractor manufacturer to obtain the correct couplings.

The tractor must be equipped with a double acting spool valve with an operator control lever and two 12.7 mm (1/2 inch) quick-release couplings at the rear of the tractor. Two quick couplings have been provided to fit to the hydraulic top link hoses (1/2-14 NPTF hose end thread size).

This section will be used to install the hoses and determine the need for the extension or rotation blocks. This information will help to determine the depth range of the aerator.

- Secure the connecting link end of the hydraulic top link to the tractor with the pins supplied with the tractor (Figure 5). Position the hydraulic top link so the rod end is toward the aerator. The cylinder ports should be positioned toward the tractor's auxiliary power hydraulics.

**Note:** If the hydraulic cylinder must be positioned with the ports facing upward, use the rotational block instead of the standard mounting block to reposition the cylinder (Figure 5). A 90 degree hydraulic fitting may be used instead of the rotational block (fittings are not supplied).

Install the rotational block as follows:

- Remove the cotter pin and pin securing the standard connecting link to the cylinder (Figure 5). Remove the connecting link from the cylinder.
- Install the rotational block to the cylinder with the pins previously removed (Figure 5).

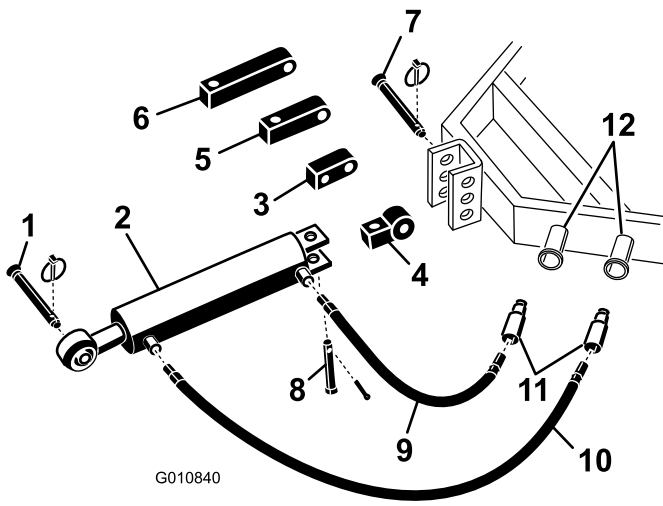

**Figure 5**

- |                           |                               |
|---------------------------|-------------------------------|
| 1. Aerator hitch pin      | 7. Tractor link pin           |
| 2. Hydraulic top link     | 8. Clevis & lynch pin         |
| 3. Rotational block       | 9. 2-1/2 foot hydraulic hose  |
| 4. Connecting link        | 10. 3-1/2 foot hydraulic hose |
| 5. 3 inch extension block | 11. Hose quick couplings      |
| 6. 5 inch extension block | 12. Tractor hydraulic ports   |

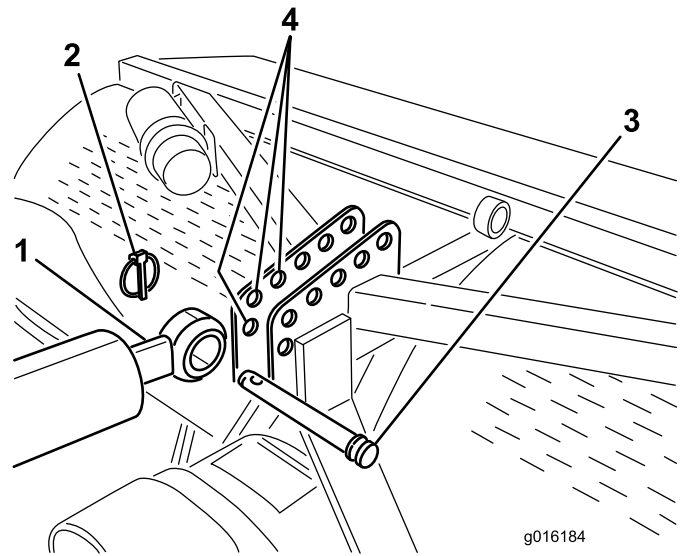

**Figure 6**

SR54 and SR70 mounting shown

- |                        |                                    |
|------------------------|------------------------------------|
| 1. Rod end of cylinder | 3. Link pin                        |
| 2. Lynch pin           | 4. Aerator bracket (forward holes) |

2. Connect the 106 cm (3-1/2 foot) long hydraulic hose to the hydraulic top link port which is closest to the aerator Figure 5. Apply Teflon tape or pipe thread sealant to the hose threads to prevent any leaks.
3. Connect the 76 cm (2-1/2 foot) long hydraulic hose to the hydraulic top link port which is closest to the tractor (Figure 5). Apply Teflon tape or pipe thread sealant to the hose threads to prevent any leaks.
4. Install quick couplings to the hydraulic hoses (1/2-14 NPTF hose end thread size). Apply Teflon tape or pipe thread sealant to the hose threads to prevent any leaks.
5. Connect the two hydraulic hose quick couplings to the ports provided on the tractor.
6. Start the tractor engine and operate the tractor spool valve to check the extend and retract motion of the hydraulic top link.

**Note:** Reverse the hose connections, at the tractor, if they do not agree with the tractor control operation.

7. Secure the rod end of hydraulic top link to the most forward hole possible in the aerator bracket with link pin and lynch pin (Figure 6, Figure 7 or Figure 8).

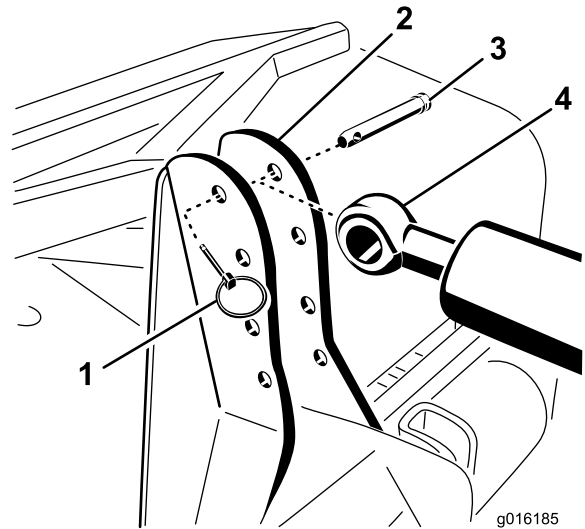

**Figure 7**

SR48 and SR72 mounting shown

- |                    |                        |
|--------------------|------------------------|
| 1. Lynch pin       | 3. Link pin            |
| 2. Aerator bracket | 4. Rod end of cylinder |

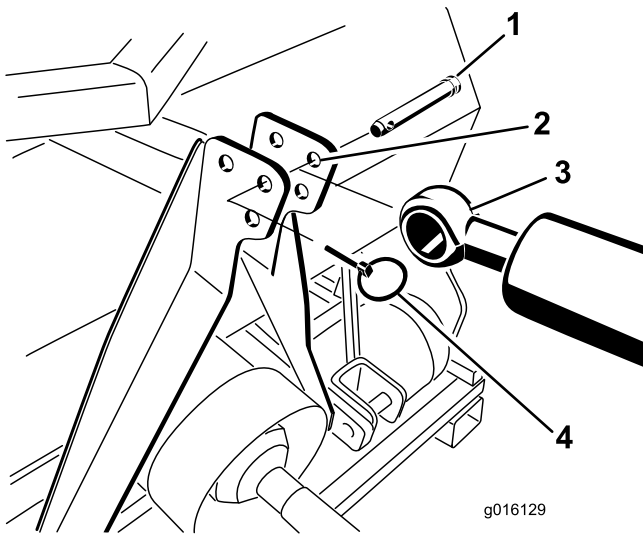

**Figure 8**  
SR75 mounting shown

- |                    |                        |
|--------------------|------------------------|
| 1. Link pin        | 3. Rod end of cylinder |
| 2. Aerator bracket | 4. Lynch pin           |

If the hydraulic cylinder does not reach the aerator mounting bracket, use an extension block instead of the standard mounting block to connect the cylinder to the tractor (Figure 5).

**Note:** If an extension block is installed and the cylinder needs to be retracted to be installed, the aerator tine heads will get closer to the ground.

Install the extension blocks as follows:

- A. Remove the cotter pin and pin securing the standard connecting link to the cylinder (Figure 5). Remove the connecting link from the cylinder.
- B. Install the required length extension block to the cylinder with the pins previously removed (Figure 5).

# 4

## Installing the Depth Gauge (Models SR48, SR54, SR70, SR72 and SR75)

### Parts needed for this procedure:

1	Depth gauge
1	Slide block
2	Machine screw, #10 x 1/2 inch
2	Screw, 1/4 x 2-1/2 inch
1	Tube clamp
1	Weld plate
1	Depth decal

### Procedure

1. Mount the depth gauge to the flat side of the slide block with two #10 x 1/2 inch machine screws, positioning the components as shown in Figure 9.

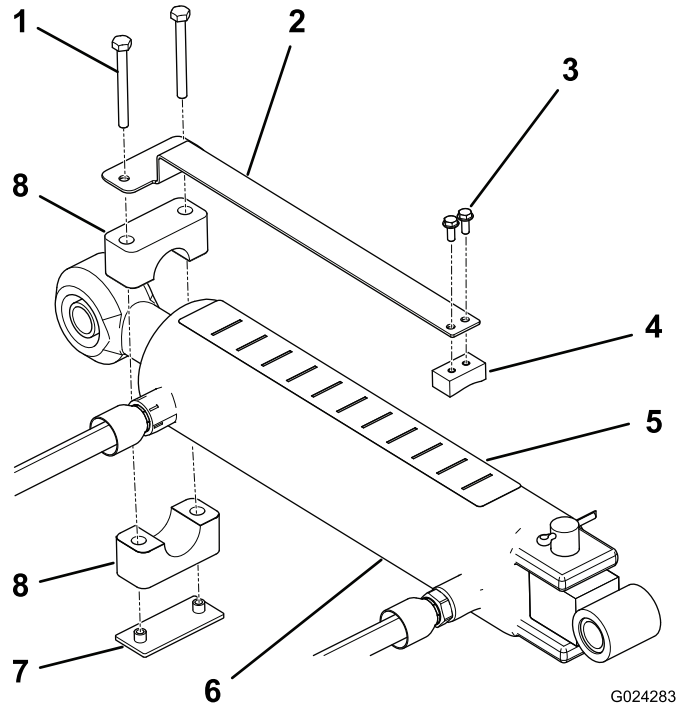

**Figure 9**

- |                      |                |
|----------------------|----------------|
| 1. Screw             | 5. Depth decal |
| 2. Depth gauge       | 6. Cylinder    |
| 3. Machine screw (2) | 7. Weld plate  |
| 4. Slide block       | 8. Tube clamp  |

2. Using the tube clamp, weld plate and two 1/4 x 2-1/2 inch screws, loosely mount the depth gauge to the rod end of the top link cylinder (Figure 9). Make sure the clamps are loose enough to allow them to be rotated to the desired position.
3. Make sure the top of cylinder is clean enough to except the installation of a decal.
4. Affix the depth decal to the top of the cylinder at a location that is visible to the operator and does not interfere with hydraulic hoses or other obstructions (Figure 9). The end of the decal with the letter "J" is to be positioned toward the aerator.
5. Check to make sure the cylinder rod can extend and retract fully without interfering with other tractor or aerator components. Then, tighten the depth gauge mounting screws when the desired location is attained.
6. The letters on the decal do not correspond to a particular depth. Run the aerator on a test plot to determine the desired setting and note the corresponding position on the depth indicator. The operator then can adjust the cylinder while in operation to a deeper setting "J" or shallower setting "A" as desired.

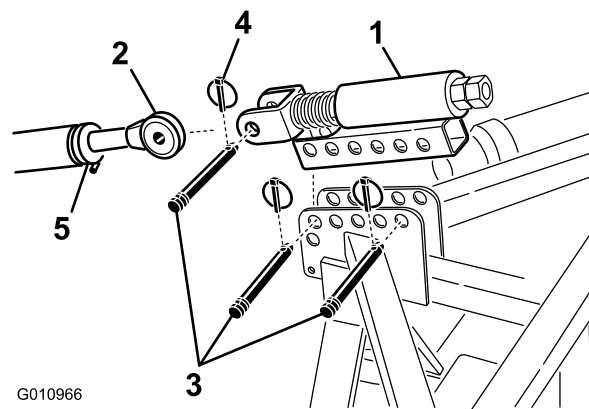

G010966

**Figure 10**

- |                           |              |
|---------------------------|--------------|
| 1. Spring loaded top link | 4. Lynch pin |
| 2. Upper link             | 5. Lock nut  |
| 3. Link pin               |              |

3. Connect the tractor upper link to the clevis on the spring loaded top link and secure with a link pin and lynch pin (Figure 10).
4. Grease the threaded steel upper link tubes.
5. Measure the length of the spring in the top link.
6. Rotate the upper link until the spring is compressed by about 13 mm (1/2 inch) (Figure 10).
7. Tighten the lock nut to secure the upper link into position.

# 5

## Connecting the Tractor Upper Link (Models SR54-S and SR70-S)

### Parts needed for this procedure:

1	Spring loaded top link
3	Link pin
3	Lynch pin

### Procedure

1. Mount the spring loaded top link to the aerator bracket with two link pins and lynch pins (Figure 10)
2. Loosen the lock nut on the tractor upper link. Adjust the upper link length until it aligns with the clevis on the spring loaded top link of the aerator (Figure 10).

# 6

## Verifying the Hydraulic Top Link Set Up

### No Parts Required

### Procedure

- Extending the hydraulic cylinder will increase the tine depth.
- Fully extend the hydraulic cylinder to determine the location of the tine heads and to verify if they contact the ground.

### **CAUTION**

**If the tine heads contact the ground, turf damage may occur.**

**Note:** On undulating turf, the operator can adjust the cylinder to maintain tine depth (cresting a hill) but it will be necessary to have the tine heads set about 2 inches below ground.

- If the tine heads contact the ground, adjust the location of the cylinder ends to move the top of the aerator closer to the tractor.
- If the tine heads do not contact the ground, extension brackets (included with aerator) can be installed to the top link to move the tine heads closer to the ground.

**Important:** When connecting the PTO, be sure that the aerator is not being lifted higher than is necessary. Lifting the machine too high will cause the PTO shaft knuckles to break (Figure 11). Never leave the PTO turning when the aerator is lifted. The PTO can be operated up to an angle of 25°, but can never exceed a 35° angle when the aerator is at its highest position or severe shaft damage may occur.

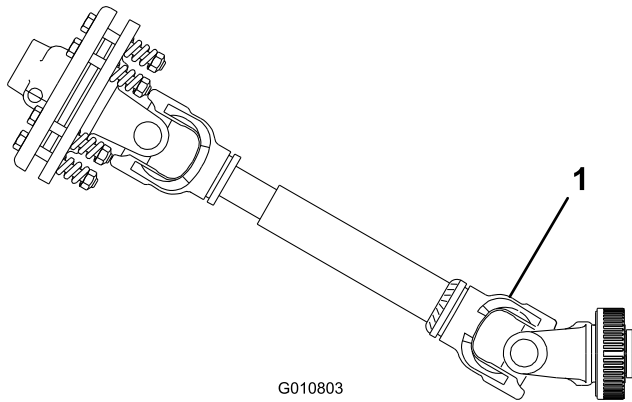

G010803  
Figure 11

1. Breakage will occur here

# 7

## Checking the PTO Angle

### No Parts Required

### Procedure

**Important:** Make sure the tines are removed before performing this operation.

With the aerator positioned on the ground and lowered to the deepest location, check the angle between the PTO and the aerator.

Lift the aerator and fully retract the hydraulic top link cylinder. Using an angle indicator, check the angle between the PTO and the aerator. If this angle is greater than 35 degrees, make adjustments to the tractor so that the aerator cannot be lifted past 35 degrees. This can be accomplished by using the tractor lift stop (if so equipped) or moving the lower links to a higher mounting hole (if so equipped).

# 8

## Fitting the PTO shaft

### Parts needed for this procedure:

1	PTO shaft
---	-----------

### Procedure

1. Move the tractor and aerator to a level surface.
2. Raise the aerator completely and fully retract the hydraulic top link cylinder or upper link (Figure 12).

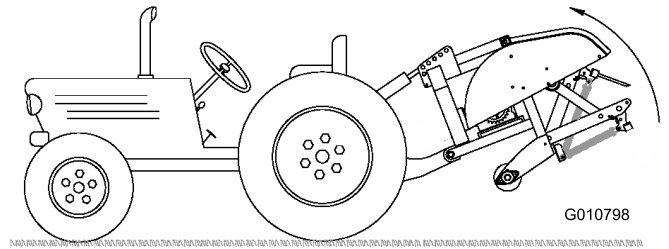

G010798  
Figure 12

3. Measure the distance from the locking groove on the end of the tractor PTO shaft to the locking groove on the aerator gearbox PTO shaft (Figure 13). Record this distance. Example: 67 cm (26.5 inches).

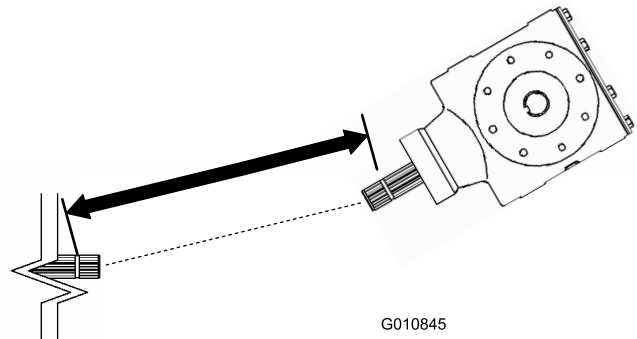

G010845  
Figure 13

1. Measure here
2. Locking groove

4. Lower the aerator to the ground and fully extend the hydraulic top link cylinder or upper link (Figure 14).

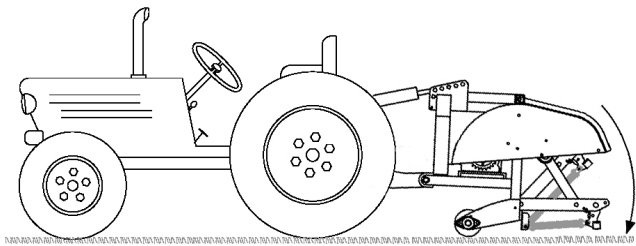

**Figure 14**

5. Measure the distance from the locking groove on the end of the tractor PTO shaft to the locking groove on the aerator gearbox PTO shaft (Figure 15). Record this distance. Example: 70 cm (27.5 inches).

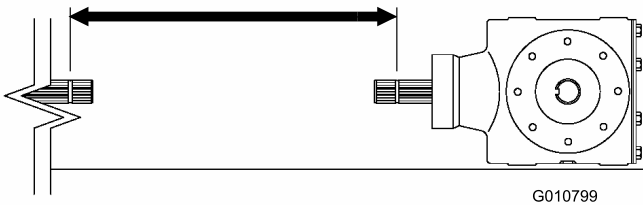

**Figure 15**

1. Measure here
2. Locking groove

6. On the PTO shaft, measure the distance from the center of locking pin ball on one end to the center of the locking pin on the other end (Figure 16). Record this distance. Example: 81 cm (32 inches).

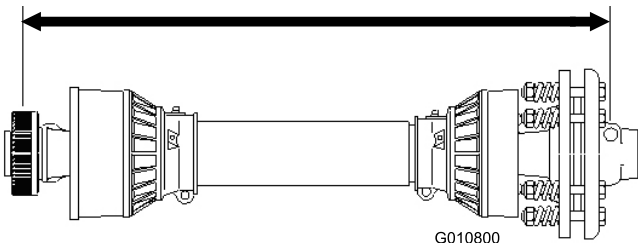

**Figure 16**

1. Measure here

7. Using the smaller of the two measurements in Figure 15 and Figure 13, subtract that distance from the distance in Figure 16. Example: 81 cm (32 inches) minus 67 cm (26.5 inches) equals 14 cm (5.5 inches).
8. The example measurements show that the shaft is 14 cm (5.5 inches) too long. Add an extra 1.2 cm (1/2 inch) to be sure that the PTO shaft will not bottom out when the aerator is lifted to its highest position.  
Example: 14 cm (5.50 inches) plus 1.2 cm (1/2 inch) equals 15 cm (6.00 inches).
9. Slide the PTO shaft tubes together until they are fully collapsed. Verify that the **inside** tube does not

protrude into the cross and bearing section of the outer tube (Figure 17). If this happens, **more** will have to be cut off the inside tube, to correct the problem. Proceed to next step.

10. Measure the distance the inside tube protrudes into the cross and bearing section of the outer tube (Figure 17). Add this distance to the dimension attained in step 8.

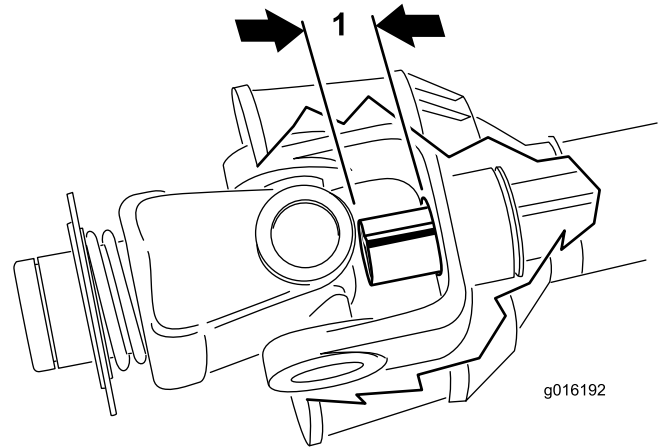

**Figure 17**

1. Cut off
2. Inside tube

11. Separate the two halves of the PTO shaft (Figure 18, illustration 1).
12. Measure the distance from the end of each tube to its safety shield (Figure 18, illustration 1). Record the distances.
13. Using the dimensions determined in step 8, locate, mark and cut off the shield and tube from each PTO half (Figure 18, illustrations 2 & 3).
- Note:** More will have to be cut off the inside tube if it was protruding into the cross and bearing section of the outer tube.
14. Using the dimensions determined in step 11, locate, mark and cut off just the safety shields to expose the tubes Figure 18, illustrations 4 & 5.
15. Carefully deburr the ends of the tubes with a file and remove all the filings from the tubes.
16. Grease the inside tube.

**Note:** Telescoping tubes must always overlap by 1/2 of their length in normal operation and at least 1/3 of their length in all working conditions. During transport, when the drive line is not rotating, the telescoping tubes must have a suitable overlap to maintain the tubes alignment and allow them to slide freely.

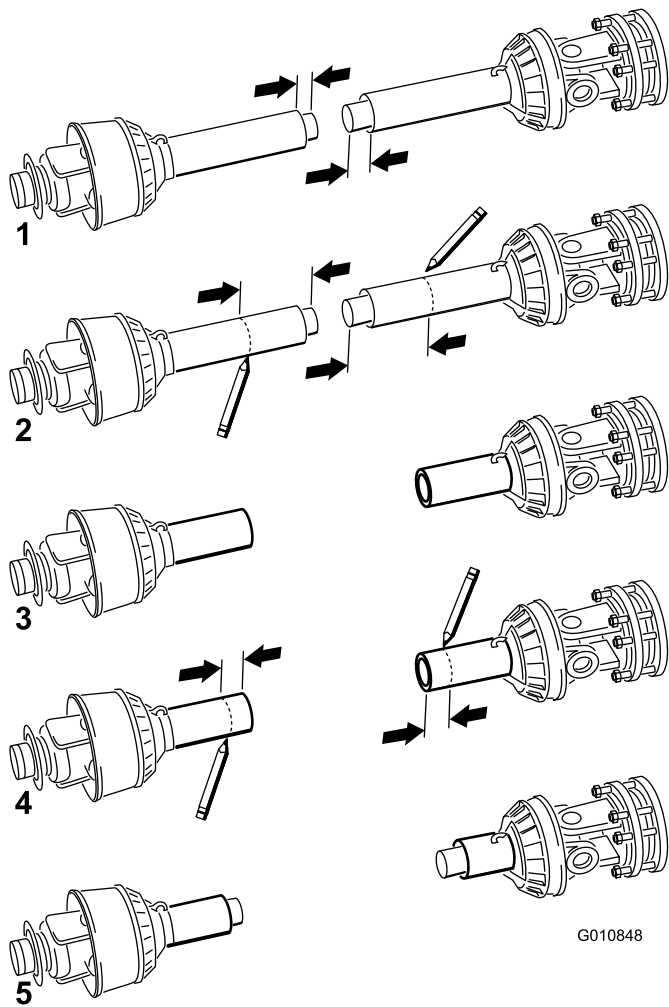

Figure 18

1. Measure here

# 9

## Installing the PTO Shield

### Parts needed for this procedure:

1	PTO Shield
---	------------

### Procedure

1. Remove the 4 bolts, lock washers and flat washers secured to the rear of the aerator gear box (Figure 19).

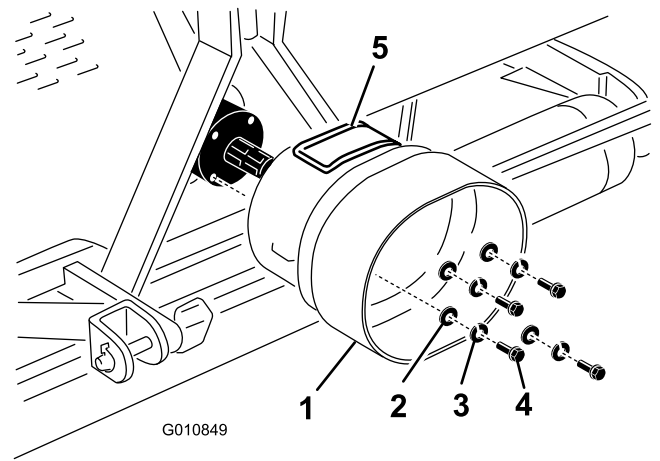

Figure 19

- |                |                 |
|----------------|-----------------|
| 1. PTO shield  | 4. Bolt         |
| 2. Flat washer | 5. Access panel |
| 3. Lock washer |                 |

2. Mount the PTO shield to the aerator gear box with the fasteners previously removed (Figure 19). When mounting the PTO shield, make sure the access panel (Figure 19) is positioned to the top or side depending on the aerator frame configuration.

# 10

## Connecting the PTO Shaft

### Parts needed for this procedure:

1	Pin (supplied with PTO shaft)
1	Nut (supplied with PTO shaft)

### Procedure

**Note:** The access panel (Figure 19) can be opened to ease the removal and installation of the PTO shaft mounting fasteners.

1. Remove the pin and nut from the PTO shaft (Figure 20).
2. Connect the clutch end of the PTO shaft to the aerator gearbox input shaft with pin and nut previously removed (Figure 20). The pin can only be inserted one way.



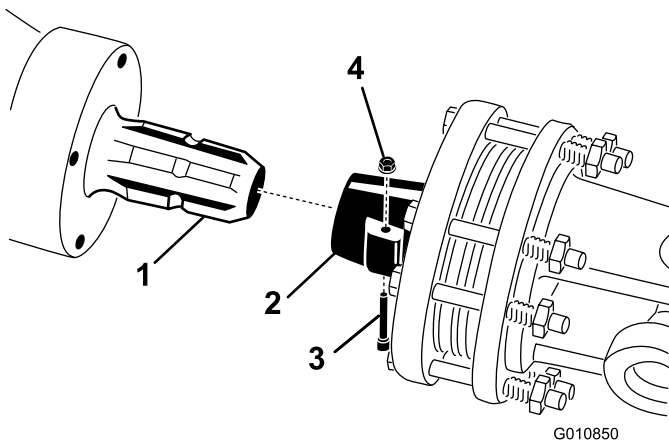

**Figure 20**

- |                        |        |
|------------------------|--------|
| 1. Gearbox input shaft | 3. Pin |
| 2. PTO shaft coupler   | 4. Nut |

**Note:** Make sure to close and latch the PTO shield access panel if opened.

**Note:** Make sure the pin is fully inserted into the yoke of the PTO.

3. Connect the PTO shaft to the tractor PTO shaft (Figure 21).

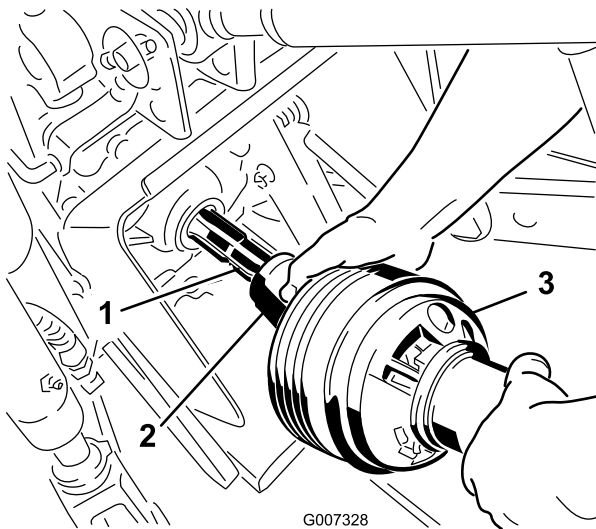

**Figure 21**

- |                         |              |
|-------------------------|--------------|
| 1. Tractor output shaft | 3. PTO shaft |
| 2. PTO shaft coupler    |              |

4. Slide the PTO shaft forward as far as the tractor allows.
5. Pull back on the locking collar to secure the PTO shaft in place. Slide the PTO shaft back and forth to make sure it is properly locked.
6. Connect the shield safety chains to the PTO shield and the tractor bracket (Figure 22). Make sure the chains remain slack when the aerator is raised or lowered.

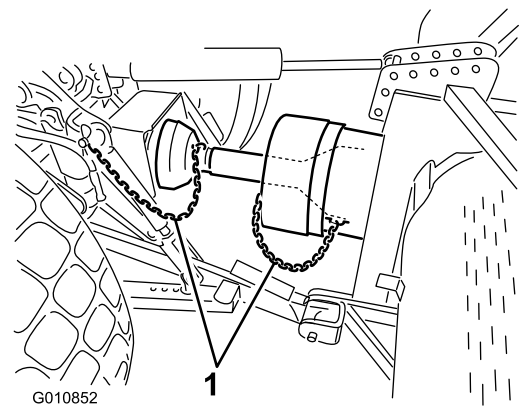

**Figure 22**

1. Safety chains

**Note:** To avoid excess lift, connect the lift arms of the tractor into the top holes of the lift bracket, if so equipped (Figure 23). The maximum angle on the PTO shaft is 35°.

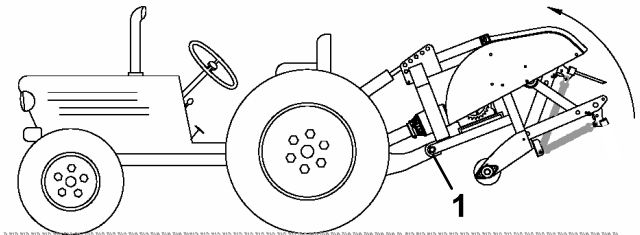
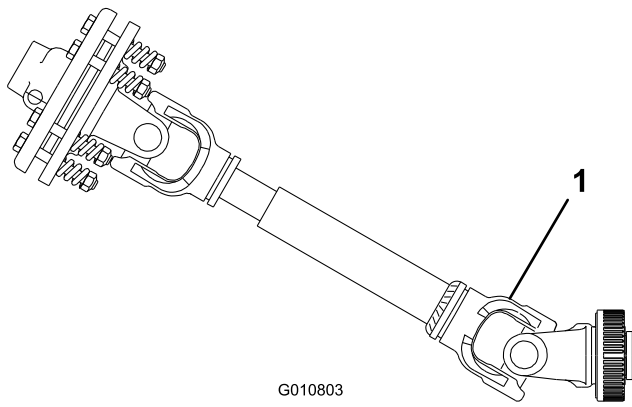

**Figure 23**

1. Top holes

**Important:** When connecting the PTO, be sure that the aerator is not being lifted higher than is necessary. Lifting the machine too high will cause the PTO shaft knuckles to break (Figure 24). Never leave the PTO turning when the aerator is lifted. The PTO can be operated up to an angle of 25°, but can never exceed a 35° angle when the aerator is at its highest position.

7. Verify that the PTO shield does not interfere with the clutch.



G010803

Figure 24

1. Breakage will occur here

# 12

## Leveling the Aerator Side-to-Side

### Parts needed for this procedure:

1	Level (not supplied)
---	----------------------

### Procedure

1. Park the tractor and aerator on a level, firm surface.
2. Place a level on top of the aerator frame to check for level side-to-side (Figure 26).

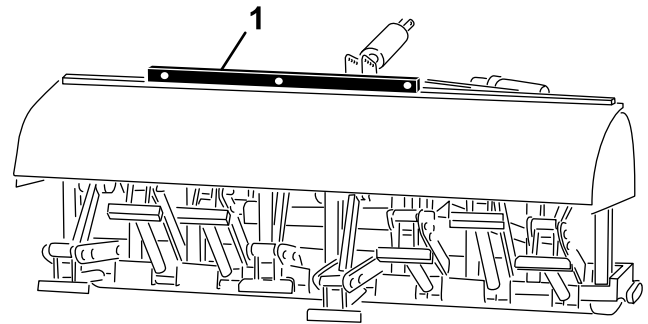

G010854

Figure 26

1. Level

3. Turn the adjustable link body (if provided) to raise or lower the link arm until the aerator is leveled side-to-side.

**Note:** Refer to tractor Operator's Manual for additional adjustment procedures.

# 11

## Adjusting the Sway Links

### No Parts Required

### Procedure

The aerator is designed to be centered with the tractor PTO shaft center line. Adjust the sway links as required.

The PTO shaft should be as straight as possible to the tractor PTO shaft.

Adjust the sway links on the lower lift arms to minimize side-to-side sway to a maximum of 1 inch (25 mm) on each side (Figure 25).

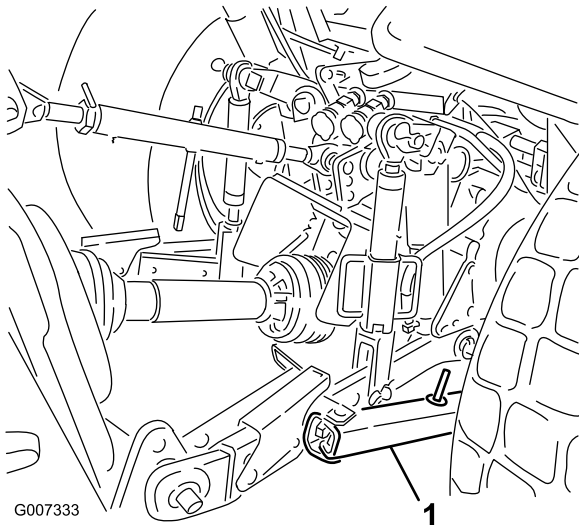

G007333

Figure 25

1. Sway link

Adjust the lower links inboard until they contact the aerator mounting plates. This will reduce the stress on the pins.

# 13

## Installing the Tines

### Parts needed for this procedure:

A/R	Tines
-----	-------

### Procedure

A wide selection of tines are available for the aerator. Choose the tine type, size and spacings required for the job. Refer to the Parts Catalog for the list of accessories.

1. Make certain the aerator is fully supported on the stands or support blocks.
2. Turn off the tractor engine and remove the key.
3. Loosen the clamping bolts and remove the previously used tines (Figure 27).

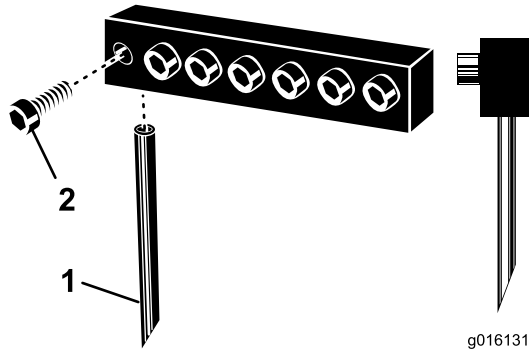

Figure 27

1. Tine
2. Clamping bolt

4. Slide the new tines into the holes sized to fit the tines selected. Never use small diameter tines in the large diameter holes - the tines should fit closely in the hole. Be sure to slide the tine up into the head until it bottoms out.

**Note:** Hollow coring tines should be positioned with the ejection slot to the rear while the solid tines should have the tine tip angle facing the machine (Figure 27).

5. Tighten the clamping bolts firmly to secure the tines. **Do not use impact tools.**
6. Set the tine angle for the new tines. Refer to Adjusting the Tine Angle in the Operation section.
7. Before aerating formal turf for the first time after installing tines, test the aerator on a less important area so that you can try alternative tractor gears and fine tune the adjustment to achieve the hole spacing and turf appearance desired.

# 14

## Setting the Tine Depth (Models SR54-S and SR70-S)

### No Parts Required

### Procedure

The tine depth can be changed by raising or lowering the rear roller. The roller height is adjusted by moving the roller adjusting bolts to the desired position.

**Note:** The aerator is shipped in Position A.

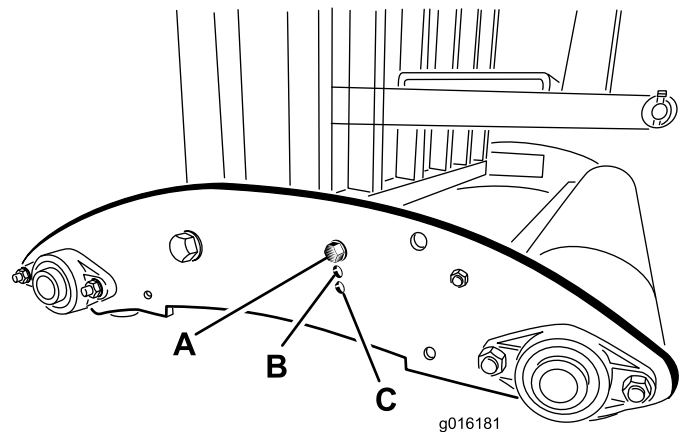

Figure 28

- **Position A** - Maximum depth
- **Position B** - Depth is decreased 38 mm (1-1/2 inches) from Position A
- **Position C** - Depth is decreased 76 mm (3 inches) from Position A

# 15

## Installing the Rear Guard

### Parts needed for this procedure:

1	Rear guard
4	Screw, 3/8 x 3-1/4 inch
12	Flat washer, .438 x 1.00 inch
4	Lock nut
2	End cap

### Procedure

1. Insert the end caps into the ends of the rear guard tubes (Figure 29).

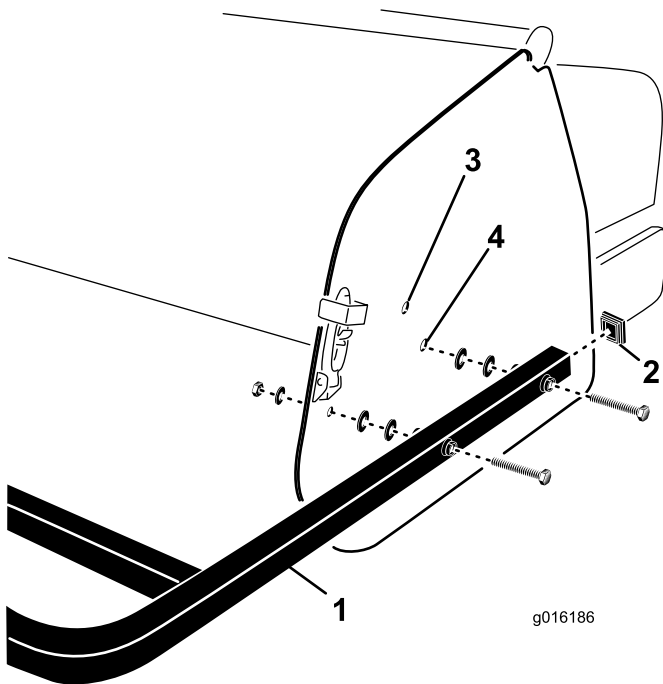

Figure 29

- |               |                        |
|---------------|------------------------|
| 1. Rear guard | 3. Upper mounting hole |
| 2. End cap    | 4. Lower mounting hole |

2. Align the holes in the rear guard mounting tubes with the holes in the aerator side plates (Figure 29).

**Note:** On SR54-S and SR70-S models, mount the ends of the tubes to the lower side plate mounting holes if the aerator tine depth is set in Position A (Figure 30). Use the upper mounting holes for depth setting Positions B or C.

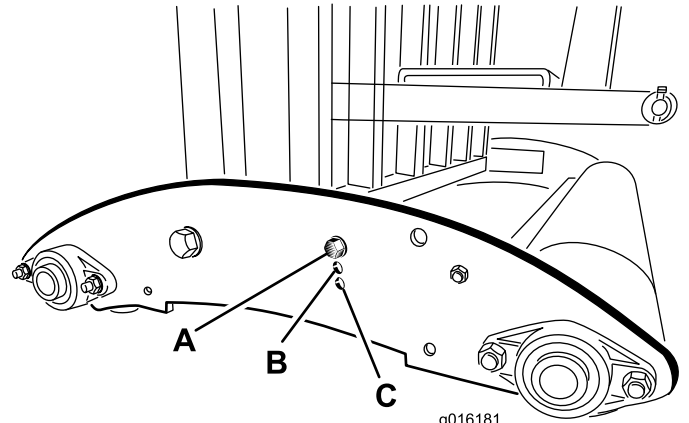

Figure 30

3. Secure the guard mounting tubes to the side plates with (4) screws, flat washers and nuts (Figure 29).

**Note:** Use the remaining washers, as required, to fill any gap between the tubes and the aerator side plates.

# 16

## Installing the Latch Lock

### Parts needed for this procedure:

2	Lock plate
2	Tap bolt
2	Retaining ring

### Procedure

1. Position the latch plate over the hood latch while aligning the mounting hole with the hole in the side plate (Figure 31).

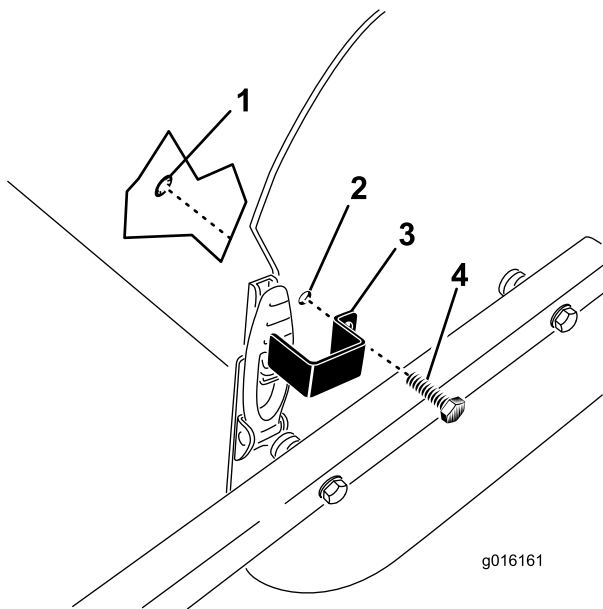

**Figure 31**

- |                   |                |
|-------------------|----------------|
| 1. Retaining ring | 3. Latch plate |
| 2. Mounting hole  | 4. Tap bolt    |

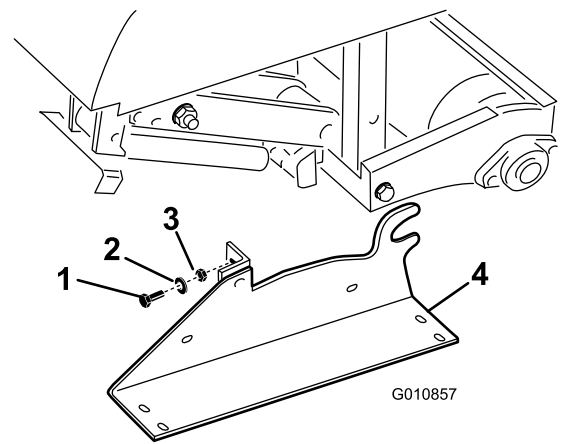

**Figure 32**

- |                |                  |
|----------------|------------------|
| 1. Bolts       | 3. Nut           |
| 2. Lock washer | 4. Storage stand |

3. Remove the storage stands.
4. Use the storage stands whenever the aerator is removed from the tractor.

# 17

## Removing the Storage Stands (Models SR54 and SR70 )

### No Parts Required

#### Procedure

1. Raise the aerator roller(s) 76-152 mm (3-6 inches) off ground. Place support blocks under the roller(s).
2. Remove the bolts, lock washers and nuts securing the storage stands to each end of the aerator (Figure 32).

# 18

## Removing the Storage Stands (Models SR48 and SR72)

### No Parts Required

#### Procedure

1. Raise the aerator roller(s) 76-152 mm (3-6 inches) off ground. Place support blocks under the roller(s).
2. Remove the bolts and nuts securing the storage stands to each end of the aerator (Figure 33).

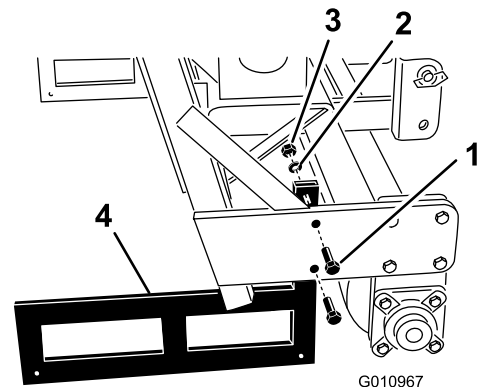

**Figure 33**

- |                |                  |
|----------------|------------------|
| 1. Bolts       | 3. Nut           |
| 2. Lock washer | 4. Storage stand |

3. Remove the storage stands.

4. Use the storage stands whenever the aerator is removed from the tractor.

**Note:** When reinstalling the storage stands, make sure they are mounted to the inside of the roller plates so the lower frame tube will rest on the top of the stands.

**Note:** The SR75 shipping stand is also the storage stand and the SR54-S and the SR70-S do not have shipping stands.

# Product Overview

## Specifications

**Note:** Specifications and design are subject to change without notice.

	<b>ProCore SR48</b>	<b>ProCore SR54</b>	<b>ProCore SR54-S</b>	<b>ProCore SR70</b>	<b>ProCore SR70-S</b>	<b>ProCore SR72</b>	<b>ProCore SR75</b>
<b>Weight with PTO &amp; Top Link</b>	694 kg (1,530 lbs.)	528 kg (1165 lbs.)	563 kg (1,242 lbs.)	623 kg (1,373 lbs.)	679 kg (1,498 lbs.)	948 kg (2,091 lbs.)	1,406 kg (3,100 lbs.)
<b>Working Width</b>	1.22 m (48")	1.37 m (54")	1.37 m (54")	1.85 m (73")	1.85 m (73")	1.83 m (72")	1.98 m (78")
<b>Working Depth (Adjustable)</b>	25–300 mm (1"-14")	25–250 mm (1"-10")	25–250 mm (1"-10")	25–250 mm (1"-10")	25–250 mm (1"-10")	25–400 mm (1"-16")	25–400 mm (1"-16")
<b>Hole Spacing</b>	75–150 mm (3"-6")	64–102 mm (2.5"-4")	64–102 mm (2.5"-4")	64–102 mm (2.5"-4")	64–102 mm (2.5"-4")	75–150 mm (3"-6")	75–150 mm (3"-6")
<b>Productivity</b>	2,325 sq.m/hr (25,000 sq. ft./hr.)	3,345 sq.m/hr. (36,000 sq. ft./hr)	3,345 sq.m/hr. (36,000 sq. ft./hr.)	4,460 sq.m/hr. (48,000 sq. ft./hr.)	4,460 sq.m/hr. (48,000 sq. ft./hr.)	3,530 sq.m/hr. (38,000 sq. ft./hr.)	4,460 sq.m/hr. (48,000 sq. ft./hr.)
<b>Recommended Tractor Size</b>	25 HP	16–18 HP	18 HP	25–35 HP	25–35 HP	45 HP	55+ HP
<b>Recommended Lift Capacity</b>	817 kg (1,800 lbs.)	544 kg (1,200 lbs.)	680 kg (1,500 lbs.)	771 kg (1,700 lbs.)	817 kg (1,800 lbs.)	1,270 kg (2,800 lbs.)	1,815 kg (4,000 lbs.)
<b>Recommended Counter Weight</b>	135 kg (300 lbs.)	70 kg (150 lbs.)	70 kg (150 lbs.)	115 kg (250 lbs.)	115 kg (250 lbs.)	135–225 kg (300–500 lbs.)	315–410 kg (700–900)
<b>Recommended PTO Speed</b>	460–500 rpm	460–500 rpm	460–500 rpm	460–500 rpm	460–500 rpm	460–460 rpm	460–500 rpm
<b>Actual Working Speed @ 400 PTO RPM (Varies with hole spacing)</b>	.8–1.3 mph	1.5–2.5 mph	1.5–2.5 mph	1.5–2.5 mph	1.5–2.5 mph	.8–1.5 mph	.8–1.5 mph
<b>Lift System</b>	Std. 3-point	Std. 3-point	Std. 3-point	Std. 3-point	Std. 3-point	Std. 3-point	Std. 3-point

## Attachments/Accessories

A selection of Toro approved attachments and accessories is available for use with the machine to enhance and expand its capabilities. Contact your Authorized Service Dealer or Distributor or go to [www.Toro.com](http://www.Toro.com) for a list of all approved attachments and accessories.

# Operation

**Note:** Determine the left and right sides of the machine from the normal operating position.

## Tractor Controls

It is necessary to familiarize yourself with the operation of the following tractor controls before you are able to operate the aerator:

- PTO Engagement
- Engine/PTO Rpm
- 3 Point Hitch (Raise/Lower)
- Auxiliary Valve Operation
- Clutch
- Throttle
- Gear Selection
- Parking brake

**Note:** Refer to tractor Operator's Manual for operating instructions.

## Principles of Operation

The tractor's three point hitch linkage/hydraulic top link lifts the aerator for transport and lowers it for operation.

The tractor's power take off (PTO) power is transmitted via shafts, gearbox and O-ring drive chains to a crankshaft which drives the tine holding arms into the turf surface.

As the tractor travels forward with the PTO engaged and the machine lowered, a series of holes are created in the turf surface.

The depth of the tine's penetration is determined by extending the hydraulic top link or setting the fixed top link to the desired position.

**Note:** Do not attempt to adjust a fixed top link while the machine is running.

The distance between the holes created is determined by the tractor's gear ratio (or hydrostatic traction pedal position) and the number of tines in each tine head. Simply changing engine rpm does not change hole spacing.

## Tractor PTO Speed

The aerator is designed to operate with a PTO speed of up to 460 rpm depending on the size/weight of the tines. Most tractors indicate a 540 PTO rpm position on the rev counters. Since the engine and PTO rpms are directly proportional, you can determine the engine rpm required for a 400 rpm PTO by calculating as follows:

$(\text{Engine rpm at 540 PTO speed}) \times (400 \div 540) = \text{required engine rpm}$

For example, if the engine rpm were 2700 for a PTO speed of 540 rpm, you would get:

$$2700 \times (400 \div 540) = 2000 \text{ rpm}$$

In this example, running your tractor at 2000 rpm now provides you with a 400 rpm PTO speed.

If your tractor indicates some other engine rpm at 540 PTO rpm, substitute that number for the 2700 that was used above.

**Note:** The recommended PTO speed for 10 inch tines and shorter is 460 rpm and 425 rpm for tines longer than 10 inches.

## Training Period

Before using the aerator, find a clear area and practice using the machine. Operate the tractor at recommended gear settings and PTO drive speeds and become thoroughly familiar with machine handling. Practice stopping and starting, raising and lowering the aerator, disengaging the PTO drive and aligning the machine with previous passes. A practice session assures confidence in the performance of the aerator and helps ensure use of proper operating techniques wherever the machine is operated.

If there are sprinkler heads, electrical or communication lines or other obstructions in the area to be aerated, mark these items to ensure they are not damaged during operation.

### **⚠ CAUTION**

**To avoid personal injury, never leave the tractor seat without first disengaging the PTO drive, setting the parking brake and stopping the engine. Never perform aerator repairs without first lowering the aerator onto the storage stand or appropriate blocking or jacks. Be sure all safety devices are secured in proper place before resuming operation.**

## Before Aerating

Inspect the area of operation for hazards that could damage the machine and remove them, if possible, or plan how to avoid them. Carry replacement tines, spring wires, springs and tools in case tines are damaged due to contact with foreign materials.

**Important:** Never operate the aerator in reverse or when it is in the raised position.

## Aerating Procedures

**Important:** If the aerator has been stored for an extended period, check to make sure the PTO slip is operational. Refer to Adjusting the PTO Clutch in the Maintenance Section.

1. Lower the aerator so that the tines are nearly to the ground at the lowest part of their stroke.



2. At a low tractor engine rpm, engage the power take off (PTO) clutch to start the aerator working.
3. Select a gear that gives a forward speed of approximately 1 to 4 km/hr. (.8 - 2.5 M.P.H.) at the rated PTO speed of 400–460 rpm (refer to the tractor Operator's Manual).
4. As the clutch is released and the tractor moves forward, lower the aerator fully onto the roller(s) and increase engine speed to give a maximum of 400–460 rpm (460 on model SR72) at the PTO.

**Important:** Never operate the tractor PTO in excess of 460 rpm or damage to the aerator could occur.

**Important:** Make sure that the roller is on the ground at all times when the aerator is operating.

5. Note the hole pattern. If you require greater hole spacing, increase forward the speed of the tractor by shifting up a gear or with a hydrostatic drive tractor, actuate the hydrostat lever or pedal to give faster speed. For closer hole spacing, decrease tractor forward speed. **Changing engine speed, while in the same gear, will not change the hole pattern.**
- Important:** Look behind frequently to ensure the machine is operating properly and alignment is maintained with previous passes.
6. Use the front tractor wheel as a guide to maintain equal lateral hole spacing with the previous pass.
7. At the end of the aeration pass, raise the aerator and quickly disengage the PTO.
8. If you back into a tight area (like a tee box), disengage the PTO and raise the aerator to its highest position. Never attempt to aerate in reverse.
9. Always clear the area of all damaged machine parts, such as broken tines, etc., to prevent anything from being picked up by mowers or other turf maintenance equipment and thrown.
10. Replace broken tines, inspect and correct damage to those still usable. Repair any other machine damage before continuing operation.

## Operating Tips

1. Engage PTO at low engine speed. Increase engine speed to achieve the desired PTO speed of 400–460 rpm (maximum) and the lower aerator. Operate at an engine rpm that the aerator runs most smoothly.
 

**Note:** Changing the engine/PTO rpm in a particular tractor gear (or fixed hydrostatic pedal position on tractors with hydrostatic transmission) will not change hole spacing.
2. Make very gradual turns when aerating. Never make sharp turns with PTO drive engaged. Plan your aeration path before lowering the aerator. Making

sharp turns while aerating will damage the aerator and the tines.

3. If tractor “bogs” down when operating on hard ground or going uphill, raise aerator slightly until speed is regained, then lower aerator again.
4. Best results are achieved when the tine entry is on a slight incline toward the rear of the machine. Use caution when extending the hydraulic top link to keep from hammering the turf with the tine heads. In some cases, you may not achieve the best results from using the pre-set holes in the camber brackets. Especially where the grass roots are short or weak. You may want to experiment using another camber setting that will set the tines on more of an incline to keep from pulling soil out of the hole.
5. Do not aerate if the ground is too hard or dry. Best results are obtained after a rain or when turf has been watered the previous day.
 

**Note:** If the roller rides up off the ground while aerating, the ground is too hard to achieve the desired depth, reduce the aeration depth until the roller contacts the ground during operation.
6. Raise aerator penetration, if ground is hard packed. Clean up cores and re-aerate at deeper penetration, preferably after watering.

## **⚠ CAUTION**

**To avoid personal injury, never leave the tractor seat without first disengaging the PTO drive, setting the parking brake and stopping the engine. Never perform aerator adjustments or repairs without first lowering the aerator onto the safety stand. Be sure all safety devices are secured in proper place before resuming operation.**

7. Look behind frequently to ensure the machine is operating properly and alignment is maintained with previous passes. A loss of one line of holes indicates a bent or lost tine. Inspect after each pass.
8. Always clear the area of all damaged machine parts, such as broken tines, etc., to prevent them from being picked up by mowers or other turf maintenance equipment and thrown.
9. Replace broken tines, inspect and correct damage to those still usable. Repair any other machine damage before commencing operation.

## Subsoil Cultivation

Subsoil cultivation, fracturing or “heave” is created by a spading motion of the tine in the soil as the aerator and tractor move forward. Quality of finish on the playing surface

after aerating will depend on various factors including turf condition, root growth and moisture content.

## Hard Ground

If the ground is too firm to obtain the desired aeration depth, the coring head can get into a “bouncing” rhythm. This is due to the hard pan the tines are attempting to penetrate. This condition can be corrected by attempting one or more of the following:

- Best results are obtained after a rain or when turf has been watered the previous day.
- Reduce the number of tines per stomper arm. Attempt to maintain a symmetrical tine configuration to evenly load the stomper arms.
- Reduce aerator penetration (depth setting) if ground is hard packed. Clean up cores, water turf, and aerate again at a deeper penetration.

Aeration of soil types built on top of hard sub soils (i.e. sand/soil cap placed over rocky ground) can cause undesired hole quality. This is caused when the aeration depth is greater than the soil cap and the sub soil is too hard to penetrate. When the tines contact this sub soil the aerator may lift and cause the top of the holes to become elongated. Reduce the aeration depth sufficiently to avoid penetration into the hard sub soil.

## Longer/Larger Tines (10 inches or more)

Using longer/larger tines can leave the front or rear of the hole tufted or slightly deformed. Hole quality for this configuration generally improves if the coring head speed is reduced 10-15% from full operating speed. For PTO powered aerators reduce the engine speed until the PTO speed is around 400 – 420 rpm. The forward spacing is not effected by reducing the engine speed. The pushed hole can also be affected by the position of the camber bracket. Refer to Adjusting the Tine Angle.

## Multi Row Adapter Heads

When using multi row adapter heads, reduce the engine speed until the PTO speed is around 400 – 420 rpm. The forward spacing is not effected by reducing the engine speed.

## Root Zone Lifting

Using multi-tine heads in conjunction with larger coring tines or large diameter solid tines can induce significant stress on the root zone of the turf. This stress can fracture the root zone and cause a lifting action to the turf. If this damage occurs try one or more of the following:

- Reduce tine density (remove some of the tines)
- Decrease coring depth (suggested in 1/2 inch increments)

- Increase forward hole spacing (change tractor transmission up one gear)
- Decrease the tine diameter (solid or coring)

## Using the Hood Prop Rods

### Model SR75 only

1. Release the latch on each side of the aerator hood.
2. Raise the hood.
3. On each side of the hood, pivot the prop rod down from magnetic storage bracket and insert it into the prop rod catch (Figure 34).

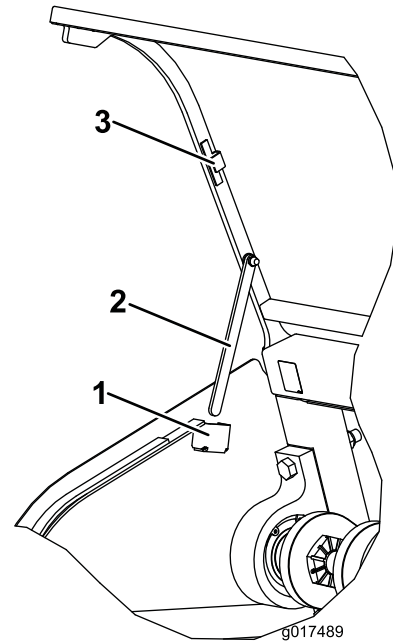

Figure 34

1. Prop rod catch
2. Prop rod
3. Magnetic storage bracket

4. When lowering the hood, return the prop rods to the magnetic storage brackets.

## Adjusting the Tine Angle

### Model SR72

Set the camber bracket (Figure 35) to the correct position based on the length of tines to be used. The head stop is set to one of five predetermined positions by choosing the hole through which the adjustment rod is bolted. These holes are presets only; for instance, by using a 10 inch tine in the 12 inch position you may achieve a smoother finish; depending on the application.

1. Disengage the PTO and engage the parking brake.
2. Stop the engine and remove the key from ignition switch.
3. Release the spring tension to the tine head (Figure 35).

- Remove the nut and bolt in the adjustment holes in the camber bracket (Figure 35).

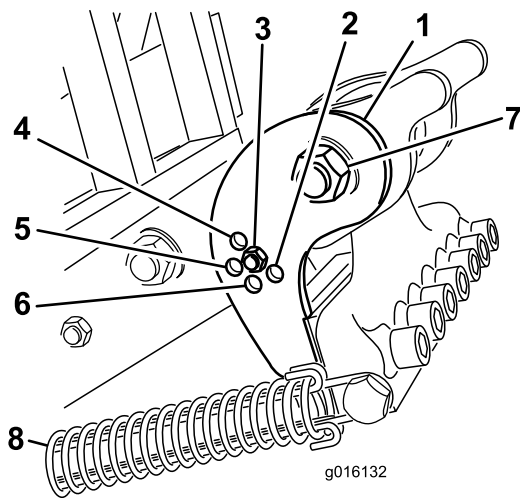

**Figure 35**

- |                   |                         |
|-------------------|-------------------------|
| 1. Camber bracket | 5. 10 inch tine         |
| 2. 16 inch tine   | 6. 14 inch tine         |
| 3. 12 inch tine   | 7. Tine head pivot bolt |
| 4. 7 inch tine    | 8. Spring               |

- Rotate the camber bracket until it is aligned with the desired hole in the arm and install the bolt and nut.

**Note:** Make sure the bolt goes through the chamber bracket and plate.

- Reconnect the spring tension to the tine head.

## Models SR54, SR54-S, SR70 and SR70-S

Set the tine angle according to the tine length by using one of the two adjustment holes in the linkage arm. These holes are presets only. When using 17.77 cm (7 inch) to 25.4 cm (10 inch) tines, the head bumper should be positioned closest to the rear of the tine head. The other position (the hole farthest from the head) may be needed due to variances of soil conditions.

- Disengage the PTO and engage the parking brake.
- Stop the engine and remove the key from ignition switch.
- Release the spring tension to the tine head (Figure 36).

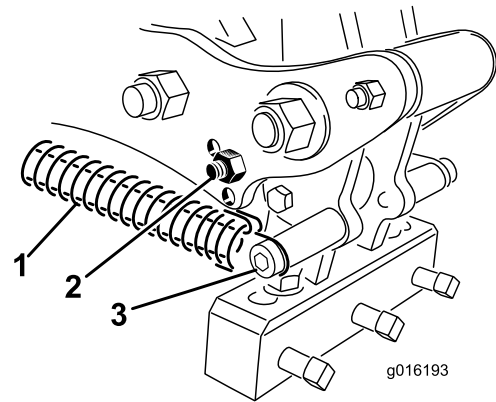

**Figure 36**

- |                |                        |
|----------------|------------------------|
| 1. Spring      | 3. Spring pin and clip |
| 2. Bumper bolt |                        |

- Remove the bumper bolt and bumper from the linkage arm and reinsert them into the other adjustment hole (Figure 36).
- Reconnect the spring tension to the tine head.

## Model SR75

Set the camber bracket (Figure 37) to the correct position based on the length of tines to be used. The head stop is set to one of five predetermined positions by choosing the hole through which the adjustment rod is bolted. These holes are presets only; for instance, by using a 10 inch tine in the 12 inch position you may achieve a smoother finish; depending on the application.

- Disengage the PTO and engage the parking brake.
- Stop the engine and remove the key from ignition switch.
- Release the spring tension to the tine head (Figure 37).

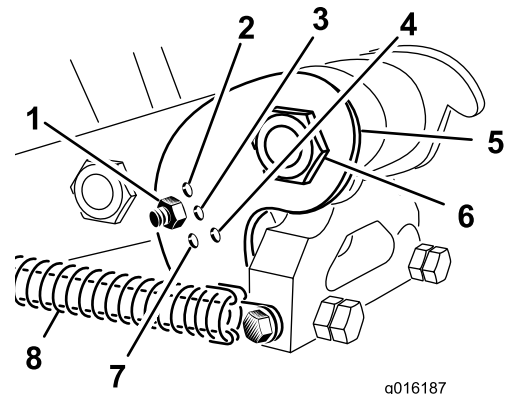

**Figure 37**

- |                 |                         |
|-----------------|-------------------------|
| 1. 10 inch tine | 5. Camber bracket       |
| 2. 7 inch tine  | 6. Tine head pivot bolt |
| 3. 12 inch tine | 7. 14 inch tine         |
| 4. 16 inch tine | 8. Spring               |

- Remove the nut and bolt in the adjustment holes in the camber bracket (Figure 37).

5. Rotate the camber bracket until it is aligned with the desired hole in the arm and install the bolt and nut (Figure 37).
- Note:** Make sure the bolt goes through the chamber bracket and plate.
6. Reconnect the spring tension to the tine head.

## Adjusting the Tine Depth (Models SR54-S and SR70-S)

The tine depth can be changed by raising or lowering the rear roller. The roller height is adjusted by moving the roller adjusting bolts to the desired position.

**Note:** The aerator is shipped in Position A.

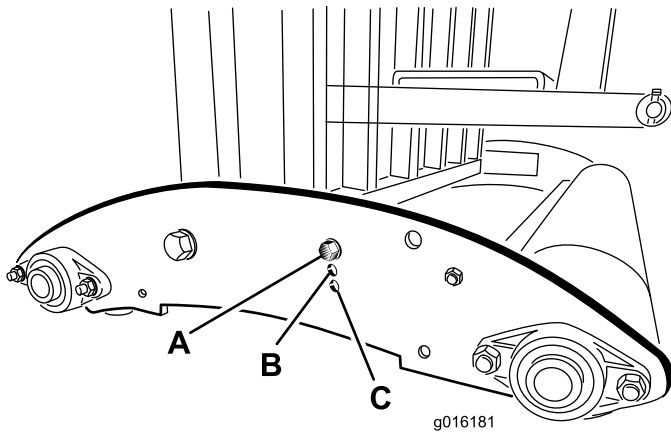

**Figure 38**

- **Position A** - Maximum depth
- **Position B** - Depth is decreased 38 mm (1-1/2 inches) from Position A
- **Position C** - Depth is decreased 76 mm (3 inches) from Position A

## Adjusting the Head Return Springs

The head return springs may be adjusted to increase or decrease the tension. Moving the spring toward the front of the aerator will increase the spring tension, thus, increasing the distance between the spring mounting posts.

1. Disengage the PTO and engage the parking brake.
2. Stop the engine and remove the key from ignition switch.
3. Release the spring tension to the linkage arm.
4. Remove the nut securing the spring mounting post bolt to the linkage arm (See figure below).
5. Remove the mounting post bolt and the mounting post from the linkage arm and reinsert them into the another adjustment hole (See figure below).

6. Install the nut securing the spring mounting post bolt to the linkage arm.
7. Reconnect the spring tension to the linkage arm.
- 8.

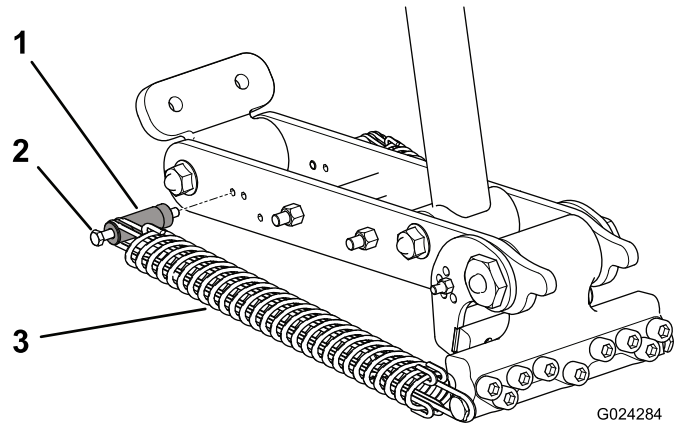

**Figure 39**  
SR48 and SR72

1. Spring mounting post
2. Bolt
3. Spring

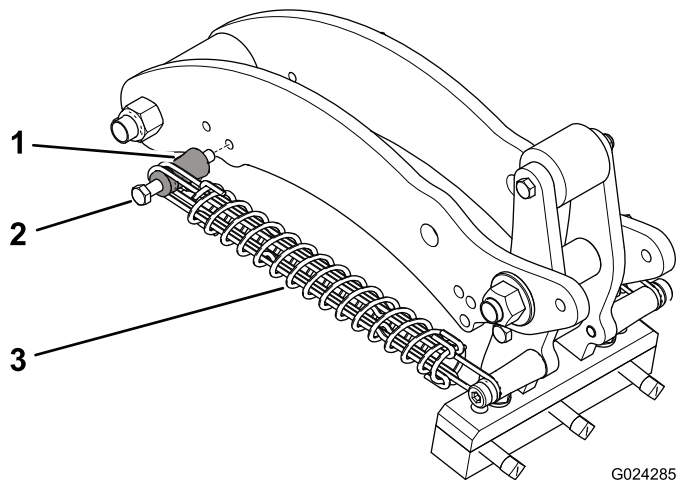

**Figure 40**  
SR54, SR54-S, SR70 and SR70-S

1. Spring mounting post
2. Bolt
3. Spring

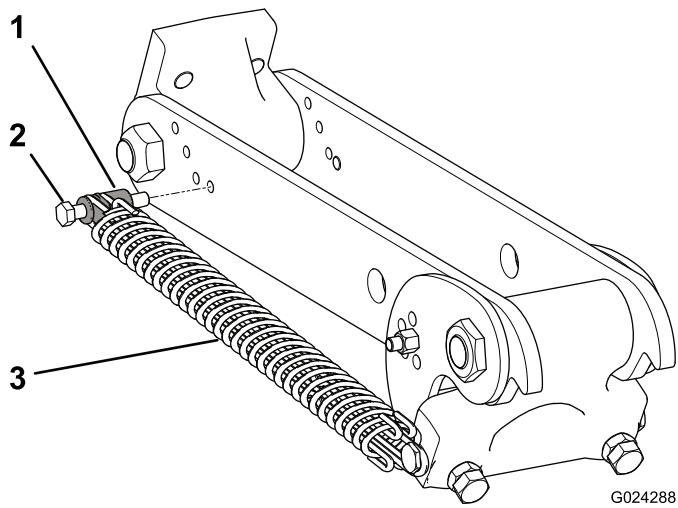

**Figure 41**  
**SR75**

1. Spring mounting post      3. Spring  
2. Bolt
- 

## Transport Operation

To begin transport operation, raise the aerator and disengage the PTO. To avoid loss of control, traverse steep inclines slowly, approach rough areas at reduced speed and cross severe undulations carefully.

**Important:** Do not exceed transport speeds of 24 km/hr. (15 m.p.h.).

## Inspection and Cleanup after Use

After daily use, thoroughly wash the machine with a garden hose **without** a nozzle so contamination and seal and bearing damage due to excessive water pressure will be avoided. A brush may be used to remove caked-on material. Use mild detergent to clean the covers. After cleaning, grease all drive lines and roller bearings, inspect for machine damage, oil leakage, component and tine wear. **Do not oil the O-ring drive chain.**

Remove, clean and oil the tines. Spray a light oil mist on coring head bearings (crank & damper links).

Clean and coat the springs with a dry lubricant like graphite or silicone.

# Maintenance

## Recommended Maintenance Schedule(s)

Maintenance Service Interval	Maintenance Procedure
After the first 50 hours	<ul style="list-style-type: none"> <li>• Change the Gearbox Oil</li> </ul>
Before each use or daily	<ul style="list-style-type: none"> <li>• Inspect the chain tension</li> <li>• Check the springs</li> <li>• Clean and lubricate springs and tine mounting screws</li> <li>• Inspect the PTO for signs of wear.</li> </ul>
Every 50 hours	<ul style="list-style-type: none"> <li>• Grease the bearings and PTO shaft</li> <li>• Check the Gearbox Oil</li> <li>• Inspect the chain tension</li> <li>• Inspect bearings</li> </ul>
Every 500 hours	<ul style="list-style-type: none"> <li>• Change the Gearbox Oil</li> <li>• Inspect bearings and replace as needed</li> </ul>
Before storage	<ul style="list-style-type: none"> <li>• Oil tine holder fasteners</li> <li>• Perform all 50 hour maintenance procedures</li> <li>• Chipped surfaces-Paint</li> <li>• Loosen the PTO clutch bolts</li> <li>• Remove and clean tines</li> <li>• Remove all debris</li> </ul>
Yearly	<ul style="list-style-type: none"> <li>• Adjust the PTO clutch Before and after storage</li> </ul>

## Lifting the Machine

### ⚠ CAUTION

When changing attachments or performing other service, use correct blocks, hoists or jacks. Make sure machine is parked on a solid level surface such as a concrete floor. Prior to raising machine, remove any attachments that may interfere with the safe and proper raising of the machine. Always chock or block tow vehicle wheels. Use storage stands or blocks to support the raised machine. If the machine is not properly supported, the machine may move or fall, which may result in personal injury.

**Note:** A hoist can be used to lift the aerator. Use the coring head eyelet as a hoist attachment point (Figure 42). Make sure the hoist has enough lift capacity. Refer to the specification chart for aerator weights.

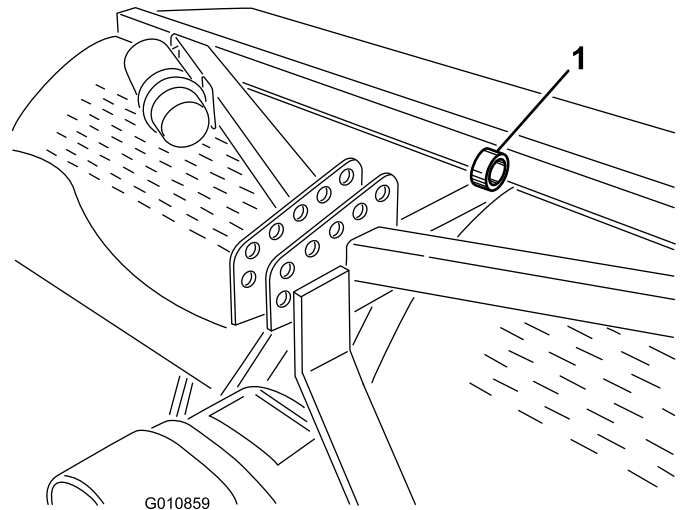

Figure 42

1. Coring head eyelet

# Greasing the Bearings

**Service Interval:** Every 50 hours

The main working bearings of the aerator are sealed and require no maintenance or lubrication. This drastically reduces the maintenance required and eliminates the risk of grease or oil being dropped onto the turf.

There are grease fittings that must be lubricated with an SAE multi purpose, high-temperature grease with high pressure (EP) performance or SAE multi purpose lithium base grease.

The lubrication points are:

PTO Shaft (3) (Figure 43)

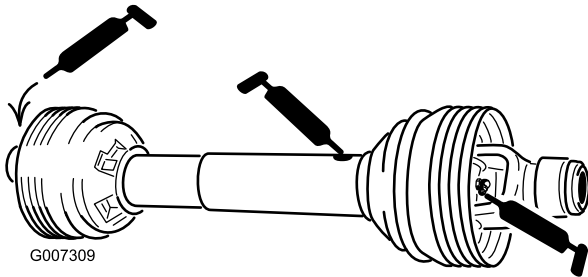

Figure 43

Roller bearings (Qty. 2 or 4, depending on model) (Figure 44)

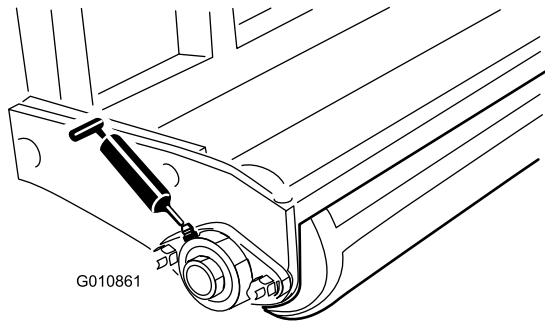

Figure 44

O-ring chain — **Do not lubricate the chain.**

**Important:** Bearings rarely fail from defects in materials or workmanship. The most common reason for failure is moisture and contamination working its way past the protective seals. Bearings that are greased will rely upon regular maintenance to purge harmful debris from the bearing area. Sealed bearings rely on an initial fill of special grease and a robust integral seal to keep contaminants and moisture out of the rolling elements.

The sealed bearings require no lubrication or short term maintenance. This minimizes routine service required and reduces the potential of turf damage due to grease contamination. These sealed bearing packages will provide good performance and life under normal use, but periodic inspections of bearing condition and seal integrity should be conducted to avoid downtime. These bearings should be inspected seasonally and replaced if damaged or worn. Bearings should operate smoothly with no detrimental characteristics such as high heat, noise, looseness or rust weeping.

Due to the operating conditions these bearing/seal packages are subject to (i.e. sand, turf chemicals, water, impacts, etc.) they are considered normal wear items. Bearings that fail due to other than defects in materials or workmanship are typically not covered under warranty.

**Note:** Bearing life can be negatively affected by improper wash down procedures. Do not use high-pressure or high volume spray directly at the bearings.

It is common for new bearings to purge some grease out the seals on a new unit. This purged grease will turn black in color due to collection of debris and not due to excessive heat. It is good practice to wipe this excess grease from the seals after the initial 8 hours. There may always appear to be a wet area around the seal lip. This is generally not detrimental to bearing life, but keeps the seal lip lubricated.

Inspect the coring head bearings every 500 operating hours and replace as needed.

## Checking the Gearbox Oil

**Service Interval:** Every 50 hours

The gearbox is filled with 80W–90 gear oil or equivalent. Allow the gear box to cool before checking the oil level.

1. Clean debris from fill plug and check plug to avoid contamination.
2. Remove the check plug from the gearbox (Figure 45).

**Note:** If the gearbox has two check plugs, use the bottom one.

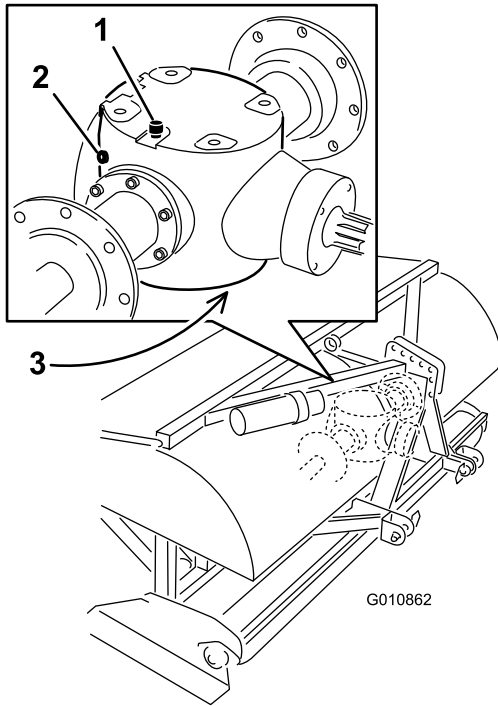

**Figure 45**

1. Vent/Fill plug
2. Check plug
3. Drain plug

3. Make sure oil is up to the bottom of the check plug hole in gearbox (Figure 45).
4. If oil level is low, remove vent/fill plug from top of gear box and replenish oil as required.
5. Install plugs.

## Changing the Gearbox Oil

**Service Interval:** After the first 50 hours

Every 500 hours

The gearbox is filled with 80W–90 gear oil or equivalent.

1. Clean debris from vent/fill plug and drain plug to avoid contamination (Figure 45).
2. Remove the vent/fill plug to relieve air draw.
3. Position a drain pan under the drain plug and remove the plug.

**Note:** The high viscosity of cool oil will extend the drain time. (approximately 30 minutes)

4. After the oil is completely drained, reinstall the drain plug.
5. Fill the gear box with high quality 80W-90 gear lube. Use the following chart to determine the gear box oil capacity.

Model	Gear Case Capacity
SR48	1.9 liters (2 quarts)
SR54	1.9 liters (2 quarts)
SR54–S	1.9 liters (2 quarts)
SR70	1.9 liters (2 quarts)
SR70–S	1.9 liters (2 quarts)
SR72	3.8 liters (4 quarts)
SR75	3.8 liters (4 quarts)

6. Install the vent/fill plug.
7. Check the oil level and replenish as required.

## Inspecting/Adjusting the Drive Chain

**Service Interval:** Before each use or daily

Every 50 hours

Check the drive chain for damage and correct adjustment. The chain should have approximately 13 mm (1/2 inch) of overall deflection ( 6 mm [1/4 inch] in each direction).

Chain tension can be adjusted by slightly loosening the main jam nut and tightening the jam rod to desired position (Figure 46 or Figure 47). Do not adjust the chain tension when the chain is hot or warm.

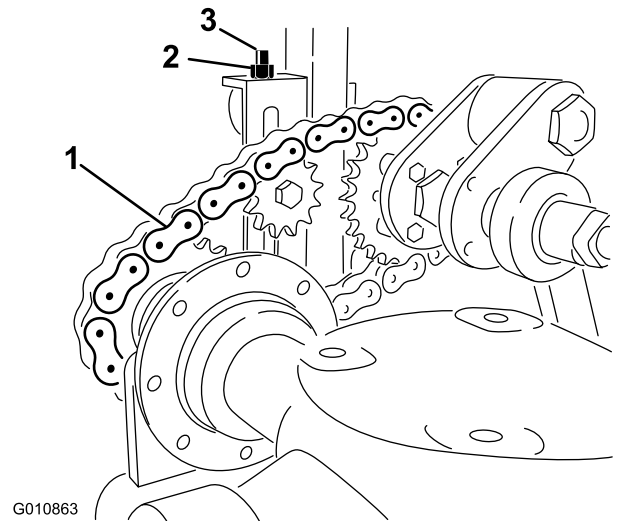
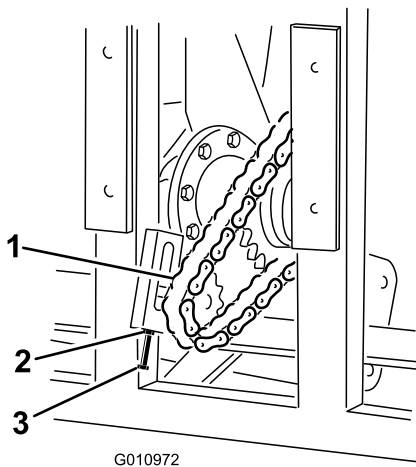

**Figure 46**

Models SR54, SR54–S, SR70, & SR72

1. Drive chain
2. Jam nut
3. Jam rod





**Figure 47**  
Model SR72

1. Drive chain
2. Jam nut
3. Jam rod

**Important:** Do not over tighten chains; excess tightening of chains can cause gearbox/sprocket damage.

## Adjusting the PTO Clutch

Service Interval: Yearly Before and after storage

### ⚠ WARNING

Friction clutches may become hot during use. *Do not touch.* To avoid the risk of fire, keep the area around the clutch free of flammable material and avoid prolonged slipping of the clutch.

1. At the end of the season, back off each of the clutch nuts 2 turns (Figure 48).

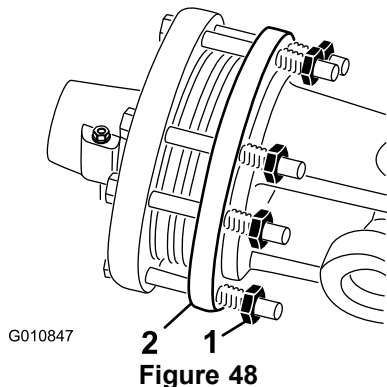

**Figure 48**

1. Clutch nut
2. Clutch

2. At the start of the new season, start the PTO and allow the clutch to slip for a few seconds before stopping the PTO. Turn back the nuts an additional 2 turns.

**Note:** Do not allow the clutch to slip for an extended amount of time.

3. If the clutch continues to slip after turning back the nuts, tighten each nut an addition 1/4 turn until the slipping ceases. Do not overtighten the nuts as shaft damage may occur.

## Fastener Torque Specifications

	Models SR54, SR54-S, SR70 & SR70-S	SR48 & SR72	SR75
Crank Shaft Nut	1288 N-m (950 ft-lbs)	1627 N-m (1200 ft-lbs.)	1491 N-m (1100 ft-lbs.)
Crank Pin Nut	1288 N-m (950 ft-lbs)	1288 N-m (950 ft-lbs)	1491 N-m (1100 ft-lbs.)
Hinge Bolt	359 N-m (265 ft-lbs.)	407 N-m (300 ft-lbs.)	1085 N-m (800 ft-lbs.)

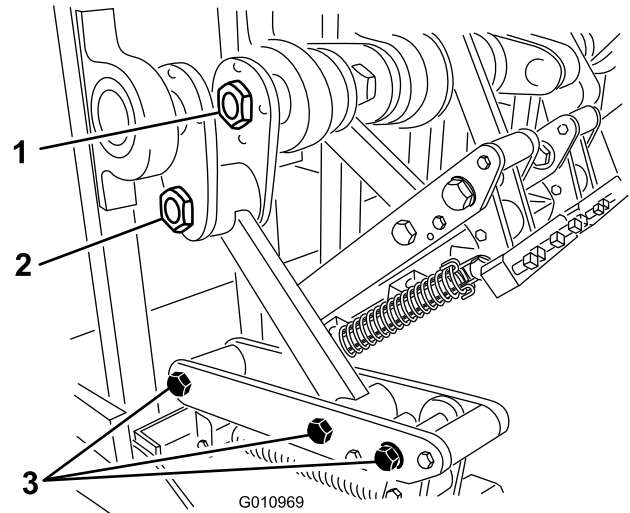

**Figure 49**

1. Crank shaft nut
2. Crank pin nut
3. Hinge bolts

# Checking the Springs

**Service Interval:** Before each use or daily

Check the springs for crossed or broken wires (Figure 50). Crossed or broken spring wires will cause an erratic hole pattern in the turf.

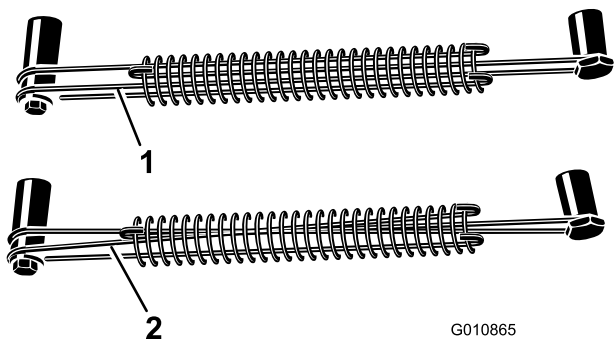

**Figure 50**

1. Correct spring wires      2. Crossed spring wires

**Note:** Replacement wires are included with the aerator. The wires are considered a consumable item.

## Adjusting the Hole Spacing

The forward hole spacing is determined by the tractor's gear ratio (or the hydrostatic traction pedal). Changing the engine RPM does not change the forward hole spacing.

The lateral hole spacing is determined by the number of tines in the tine heads.

## Removing the Aerator from the Tractor

1. Stop the aerator on a level surface, not on a slope.
2. Disengage the PTO and engage the parking brake.
3. Raise the aerator roller(s) 3-6 inches off ground. Place support blocks under the roller(s).
4. Stop the engine and remove the key from ignition switch.
5. Before leaving the Operator's seat on tractor, wait for engine and all moving parts to stop.
6. Remove the tines.
7. Install the storage stand.
8. Slowly lower aerator until storage stands contact ground.
9. Remove the pin securing the top link to the aerator bracket. Retain pin with aerator. Also, on models with a hydraulic top link, disconnect the hydraulic hoses and the connecting link from the tractor. Cap the hydraulic hoses. Store these components with the aerator.

10. Disconnect the safety shield chains from PTO shaft.
11. Pull back on the lock collar to disconnect the power shaft from the tractor PTO shaft.
12. Slide the PTO shaft back and remove from tractor.
13. Connect the PTO safety chain to the aerator to prevent the PTO shaft from contacting the ground.
14. Remove the pins securing the lower link arms to the aerator brackets. Retain pins with aerator.

# Trouble Shooting

Problem	Solution
Springs are breaking or not pulling back the head to normal position.	Slow the PTO speed of the tractor. The longer and heavier the tines, the greater the centrifugal force on the head. Check for crossed or broken spring wires.
Holes are elongated or picking.	Adjust the angle of the tine or change the tractor ground speed. Make sure that the aerator can be lowered at least 5 cm (2 inches) below flat ground level to allow for undulation.
Tines are hitting the ground with an erratic pattern.	<ul style="list-style-type: none"> <li>• Check for crossed or broken spring wires.</li> <li>• Slow the PTO speed of the tractor.</li> </ul>
PTO clutch slips excessively.	Adjust tines to a shallower depth. Review clutch adjustment procedure. Replace PTO clutches.
Turf is pulling up with coring tines.	Shallow-rooted turf may require solid tines the first time.
The soil is too hard for full penetration.	Aerate at a depth that the machine can achieve, water overnight, and then increase the depth. Repeat if necessary until soil can be aerated at desired depth.
Coring tines are breaking.	You are trying to get too much depth for the soil condition. See above and aerate to a shallower depth.
Tines will not stay in the head.	Tighten the tine holder bolts; do not use jam nuts or impact wrench. If the bolt will not hold the tine, replace it.
Tines pull the soil up when the machine is raised.	Raise the machine part of the way out of the soil before disengaging the PTO.
The machine will not turn.	Make sure the PTO, drive shaft and drive chains are working properly.
The tractor has difficulty lifting the aerator.	Move tractor lift arms 76.19 mm (3") to 101.6 mm (4") closer to the aerator. Make sure the tractor has the capacity to lift the aerator.
The hydraulic top link cylinder is spongy. (It "gives" and moves in and out a short span when force is applied.	Air is in the cylinder or lines and must be bled out.
Machine is noisy or knocking.	<ul style="list-style-type: none"> <li>• Crank pin nut has vibrated loose.</li> <li>• Chains are too loose.</li> <li>• Bolts on the bottom of the frame at the rear of the main arm have vibrated loose.</li> <li>• Check oil level in gearbox.</li> </ul>
The hydraulic top link cylinder can not be fully retracted (PTO shaft jams).	The PTO shaft is too long for your tractor and should be cut to the correct length.
The tractor is difficult to steer when in transport.	<ul style="list-style-type: none"> <li>• Add weight to the front of the tractor.</li> <li>• Check tire pressure and adjust as required.</li> </ul>
Camber bracket damage	<ul style="list-style-type: none"> <li>• Do not store the aerator, on the ground, with tines installed.</li> <li>• Do not run the coring head, for an extended time at high RPM, when the tines are out of the ground.</li> </ul>

# Storage

At the end of an aerating season or when the aerator will not be used for a long period, it is good practice to carry out the following preventative maintenance.

1. Clean off any dirt or grease that may have accumulated on the aerator or any of the moving parts.
2. Remove and clean out tines. Coat tines and tine fasteners with oil to prevent rusting during storage.
3. Open the hood and clean out the inside of the machine.
4. Lubricate all grease fittings and tine fastener screw threads.
5. Store the machine on the provided storage stands on a hard, dry surface.
6. Loosen the PTO clutch bolts two turns.
7. Connect the PTO safety chain to the aerator in stored position to prevent damage or remove the PTO and store under the hood to minimize corrosion.
8. Paint the roller and touch-up any other scratches on the painted surfaces.
9. Replace any missing or damaged decals.
10. Store the aerator inside a dry secure building. Inside storage will reduce maintenance, give a longer working life and increase the residual value of the machine. If inside storage is not available, cover with a heavy sheet or tarpaulin and secure tightly.

# Notes:

**Notes:**

**Notes:**



# Toro Commercial Aerator Products Warranty

A two-Year Limited Warranty

## Conditions and Products Covered

The Toro Company and its affiliate, Toro Warranty Company, pursuant to an agreement between them, jointly warrant your Toro Hydroject or ProCore Aerator ("Product") to be free from defects in materials or workmanship for two years or 500 operational hours\*, whichever occurs first. This warranty is applicable to all products with the exception of Aerators (refer to separate warranty statements for these products).

Where a warrantable condition exists, we will repair the Product at no cost to you including diagnostics, labor, parts, and transportation. This warranty begins on the date the Product is delivered to the original retail purchaser.

\* Product equipped with an hour meter.

## Instructions for Obtaining Warranty Service

You are responsible for notifying the Commercial Products Distributor or Authorized Commercial Products Dealer from whom you purchased the Product as soon as you believe a warrantable condition exists. If you need help locating a Commercial Products Distributor or Authorized Dealer, or if you have questions regarding your warranty rights or responsibilities, you may contact us at:

Commercial Products Service Department  
Toro Warranty Company  
8111 Lyndale Avenue South  
Bloomington, MN 55420-1196  
952-888-8801 or 800-952-2740  
E-mail: [commercial.warranty@toro.com](mailto:commercial.warranty@toro.com)

## Owner Responsibilities

As the Product owner, you are responsible for required maintenance and adjustments stated in your *Operator's Manual*. Failure to perform required maintenance and adjustments can be grounds for disallowing a warranty claim.

## Items and Conditions Not Covered

Not all product failures or malfunctions that occur during the warranty period are defects in materials or workmanship. This warranty does not cover the following:

- Product failures which result from the use of non-Toro replacement parts, or from installation and use of add-on, or modified non-Toro branded accessories and products. A separate warranty may be provided by the manufacturer of these items.
- Product failures which result from failure to perform recommended maintenance and/or adjustments. Failure to properly maintain your Toro product per the recommended maintenance listed in the *Operator's Manual* can result in claims for warranty being denied.
- Product failures which result from operating the Product in an abusive, negligent or reckless manner.
- Parts subject to consumption through use unless found to be defective. Examples of parts which are consumed, or used up, during normal Product operation include, but are not limited to, brakes pads and linings, clutch linings, blades, reels, bed knives, tines, spark plugs, castor wheels, tires, filters, belts, and certain sprayer components such as diaphragms, nozzles, and check valves, etc.
- Failures caused by outside influence. Items considered to be outside influence include, but are not limited to, weather, storage practices,

contamination, use of unapproved coolants, lubricants, additives, fertilizers, water, or chemicals, etc.

- Normal noise, vibration, wear and tear, and deterioration.
- Normal "wear and tear" includes, but is not limited to, damage to seats due to wear or abrasion, worn painted surfaces, scratched decals or windows, etc.

## Parts

Parts scheduled for replacement as required maintenance are warranted for the period of time up to the scheduled replacement time for that part. Parts replaced under this warranty are covered for the duration of the original product warranty and become the property of Toro. Toro will make the final decision whether to repair any existing part or assembly or replace it. Toro may use remanufactured parts for warranty repairs.

## Maintenance is at Owner's Expense

Engine tune-up, lubrication cleaning and polishing, replacement of Items and Conditions Not Covered, filters, coolant, and completing recommended maintenance are some of the normal services Toro products require that are at the owner's expense.

## General Conditions

Repair by an Authorized Toro Distributor or Dealer is your sole remedy under this warranty.

**Neither The Toro Company nor Toro Warranty Company is liable for indirect, incidental or consequential damages in connection with the use of the Toro Products covered by this warranty, including any cost or expense of providing substitute equipment or service during reasonable periods of malfunction or non-use pending completion of repairs under this warranty. Except for the Emissions warranty referenced below, if applicable, there is no other express warranty.**

All implied warranties of merchantability and fitness for use are limited to the duration of this express warranty. Some states do not allow exclusions of incidental or consequential damages, or limitations on how long an implied warranty lasts, so the above exclusions and limitations may not apply to you.

This warranty gives you specific legal rights, and you may also have other rights which vary from state to state.

## Note regarding engine warranty:

The Emissions Control System on your Product may be covered by a separate warranty meeting requirements established by the U.S. Environmental Protection Agency (EPA) and/or the California Air Resources Board (CARB). The hour limitations set forth above do not apply to the Emissions Control System Warranty. Refer to the Engine Emission Control Warranty Statement printed in your *Operator's Manual* or contained in the engine manufacturer's documentation for details

## Countries Other than the United States or Canada

Customers who have purchased Toro products exported from the United States or Canada should contact their Toro Distributor (Dealer) to obtain guarantee policies for your country, province, or state. If for any reason you are dissatisfied with your Distributor's service or have difficulty obtaining guarantee information, contact the Toro importer. If all other remedies fail, you may contact us at Toro Warranty Company.