



Count on it.

Parts Catalog

ProCore® SR72 Aerator

Model No. 09935—Serial No. 314000001 and Up



Ordering Replacement Parts

To order replacement parts, please supply the part number, the quantity, and the description of each part desired.

Understanding Reference Numbers

Each identified part in an illustration has a reference number. The reference number for a part also appears in the parts list, along with other information about the part.

This catalog uses two special reference number formats, one to indicate parts in a service assembly and another to indicate the quantity of a given part in an illustration.

Service Assembly Reference Numbers

Parts in service assemblies have reference numbers in the form a:b. The a represents the reference number of the entire service assembly and the b represents a sequential number unique to each part within the service assembly.

For example, a wheel assembly might be identified by reference number 6, the tire by 6:1, the valve by 6:2, and the wheel by 6:3. When you order the assembly identified by reference number 6, you receive all parts identified by reference numbers 6:1, 6:2, and 6:3. However, you may also order any part individually. Reference numbers of this type appear in illustration and in parts lists.

Reference Numbers Indicating Quantity

In an illustration, if a reference number indicates more than one part, the reference number has the form nX y. The n represents the quantity of the part, the X is the multiplication symbol, and the y represents the reference number.

For example, in an illustration, the reference number 2X 37 means that two of the parts identified by reference number 37 are indicated.

List of Abbreviations

AR: as required

ASM: assembly

BBC: blade brake control

BHTF: button head thread forming

CARR: carriage

CCW: counter clockwise

CW: clockwise

DEG: degrees

DPA: Dual Point Adjustment

ECM: electronic control module

EXT: external

FH: flat head

GA: gauge

HD: heavy-duty

HF: hex flange

HH: hex head

HHF: hex head flange

HHFTF: hex head flange thread forming

HJ: hex jam

HLH: hex lag head

HOC: height-of-cut

HSBH: hex socket button head

HSFH: hex socket flat head

HSH: hex socket head

HWH: hex washer head

HWHTF: hex washer head thread forming

HYD: hydraulic

LH: left hand

LP: Liquefied Petroleum Gas

LPG: Liquefied Petroleum Gas

NI: nylon insert

NPTF: national pipe thread fine

PFH: phillips flat head

PPH: phillips pan head

PPHTF: phillips pan head thread forming

PRH: phillips round head

PTH: phillips truss head

PTO: power-take-off

RH: right hand

ROPS: roll-over protection system

RRB: rear roller brush

SFH: slotted fillister head

SHH: slotted hex head

SHWH: slotted hex washer head

SPH: slotted pan head

SQH: square head

SRH: slotted round head

STD: standard

TAP: self tapping

TTH: torx truss head

Contents

Drive Assembly	4
Gearbox Assembly No. SG506000	5
PTO Shaft Assembly No. SG528016	6
Frame and Roller Assembly	7
Hydraulic Cylinder Assembly SG715010	9
LH Outside Crankshaft Assembly	10
LH Crankshaft Assembly	11
Center Crankshaft Assembly	12
RH Crankshaft Assembly	13
RH Outside Crankshaft Assembly	14
Connecting Rod Assembly	15
Lower Arm and Hinge Assembly	16
Cover Assembly	17
Rear Guard Assembly	18
Attachments and Accessories	19

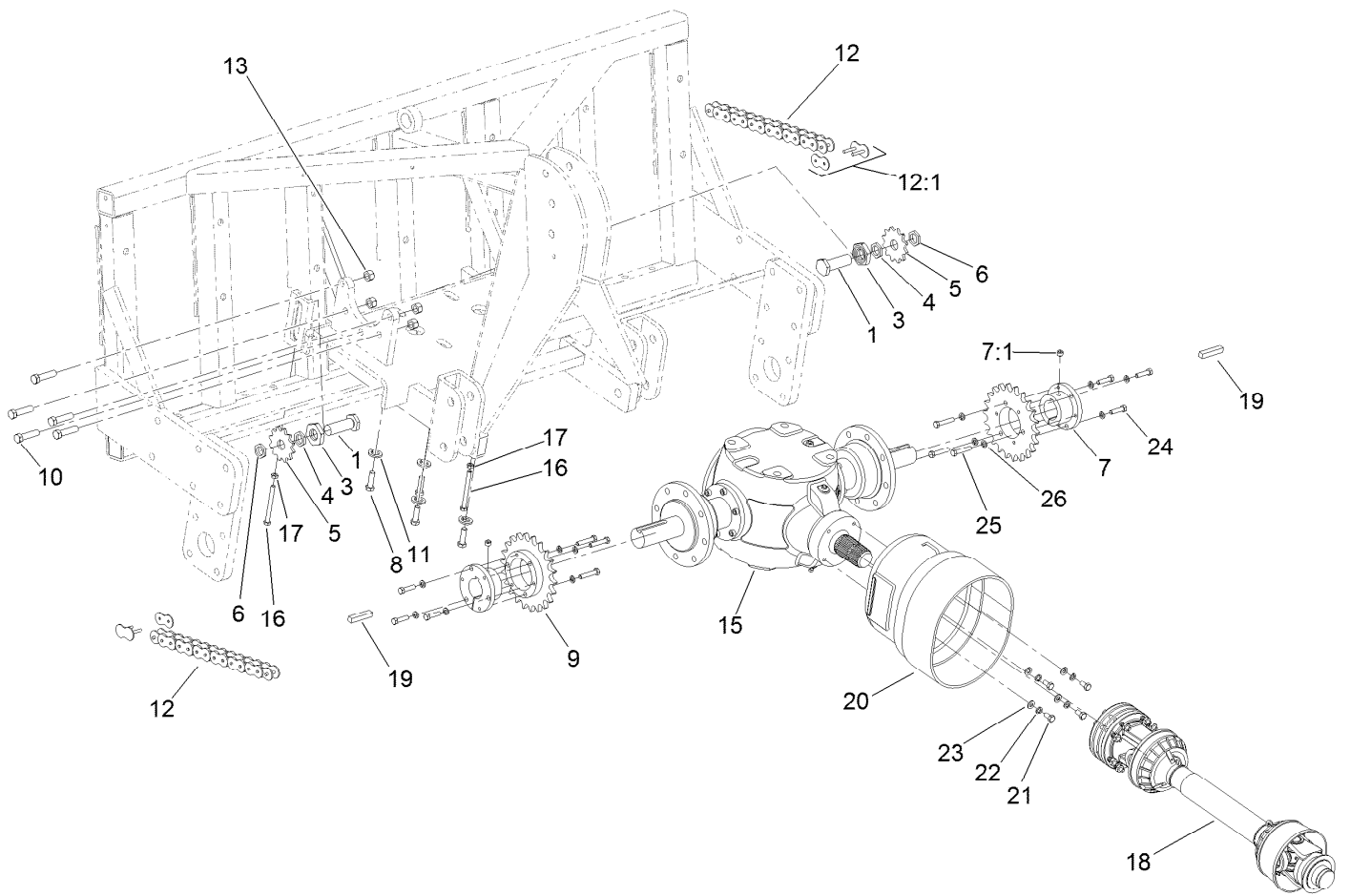

Drive Assembly

<i>Ref.</i>	<i>Part Number</i>	<i>Qty.</i>	<i>Description</i>	<i>Ref.</i>	<i>Part Number</i>	<i>Qty.</i>	<i>Description</i>
1	SG584100	2	Screw-HH Special	13	99-4371	10	Nut-Lock
3	SG564100	2	Nut-HJ	15	SG506000	1	Gearbox ASM
4	SG571450	2	Nut-HJ	16	SG584300	2	Screw-HH
5	SG511280	2	Sprocket-Idler	17	3217-7	2	Nut-Hex
6	SG571100	2	Nut-Lock	18	SG526016	1	PTO #6
7	SG550177	2	Hub-Sprocket	19	SG555500	2	Key-Square
7:1	3246-4	1	Screw-Set	20	SG4171401	1	Cone-Shaft, Lg
8	33119-040	4	Screw-HH	21	33115-020	4	Screw-HH
9	SG510522	2	Sprocket-22 Tooth, 6 Bolt	22	48-9590	4	Washer-Lock
10	SG562562	10	Screw-HH	23	3256-24	4	Washer-Flat
11	100-7607	4	Washer-Lock	24	323-43	6	Screw-HH
12	SG580148	2	O-Ring Chain ASM	25	323-32	6	Screw-HH
12:1	SG581081	1	Link-Master, O-Ring	26	3253-21	12	Washer-Lock

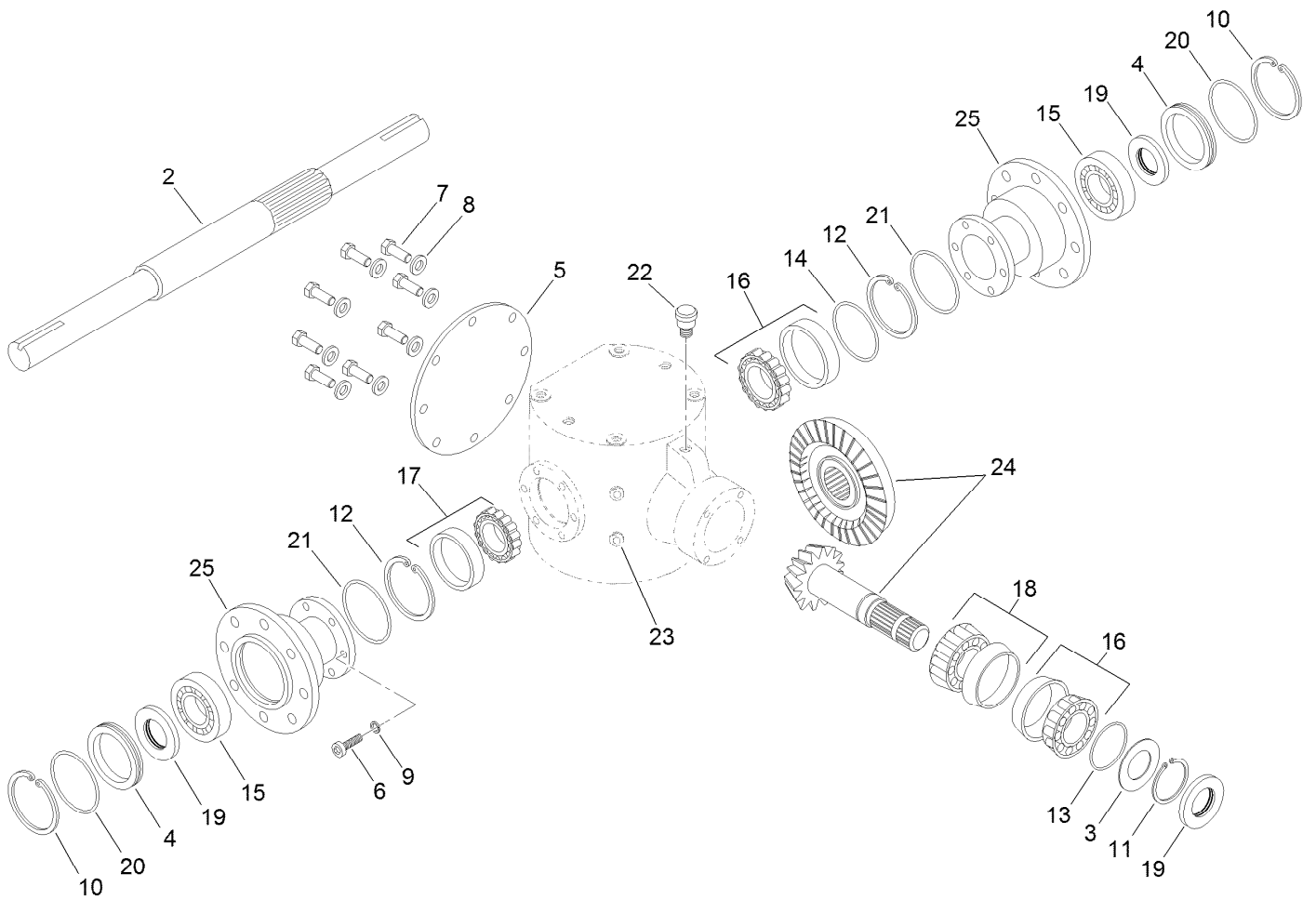

Gearbox Assembly No. SG506000

<i>Ref.</i>	<i>Part Number</i>	<i>Qty.</i>	<i>Description</i>	<i>Ref.</i>	<i>Part Number</i>	<i>Qty.</i>	<i>Description</i>
2	119-3233	1	Shaft-Output	14	119-3241	1	Ring
3	119-3238	1	Spacer	15	119-3211	2	Bearing-Ball
4	119-3203	2	Spacer	16	119-3212	2	Bearing-Roller
5	119-3204	1	Cover-Housing, Gearbox	17	119-3213	1	Bearing-Roller
6	119-3205	12	Screw-HSH	18	119-3214	1	Bearing-Roller
7	119-3239	8	Screw-HH	19	119-3215	3	Seal-Oil
8	119-3206	8	Washer	20	119-3216	2	Seal-Oil
9	119-3207	12	Washer	21	119-3217	2	Seal-Oil
10	119-3208	2	Ring-Snap	22	119-3218	1	Plug-Breather
11	119-3209	1	Ring-Snap, External	23	119-3219	5	Plug-HSH
12	119-3210	2	Ring-Snap, Internal	24	119-3242	1	Bevel Gear ASM
13	119-3240	1	Ring	25	119-3234	2	Extension-Gearbox

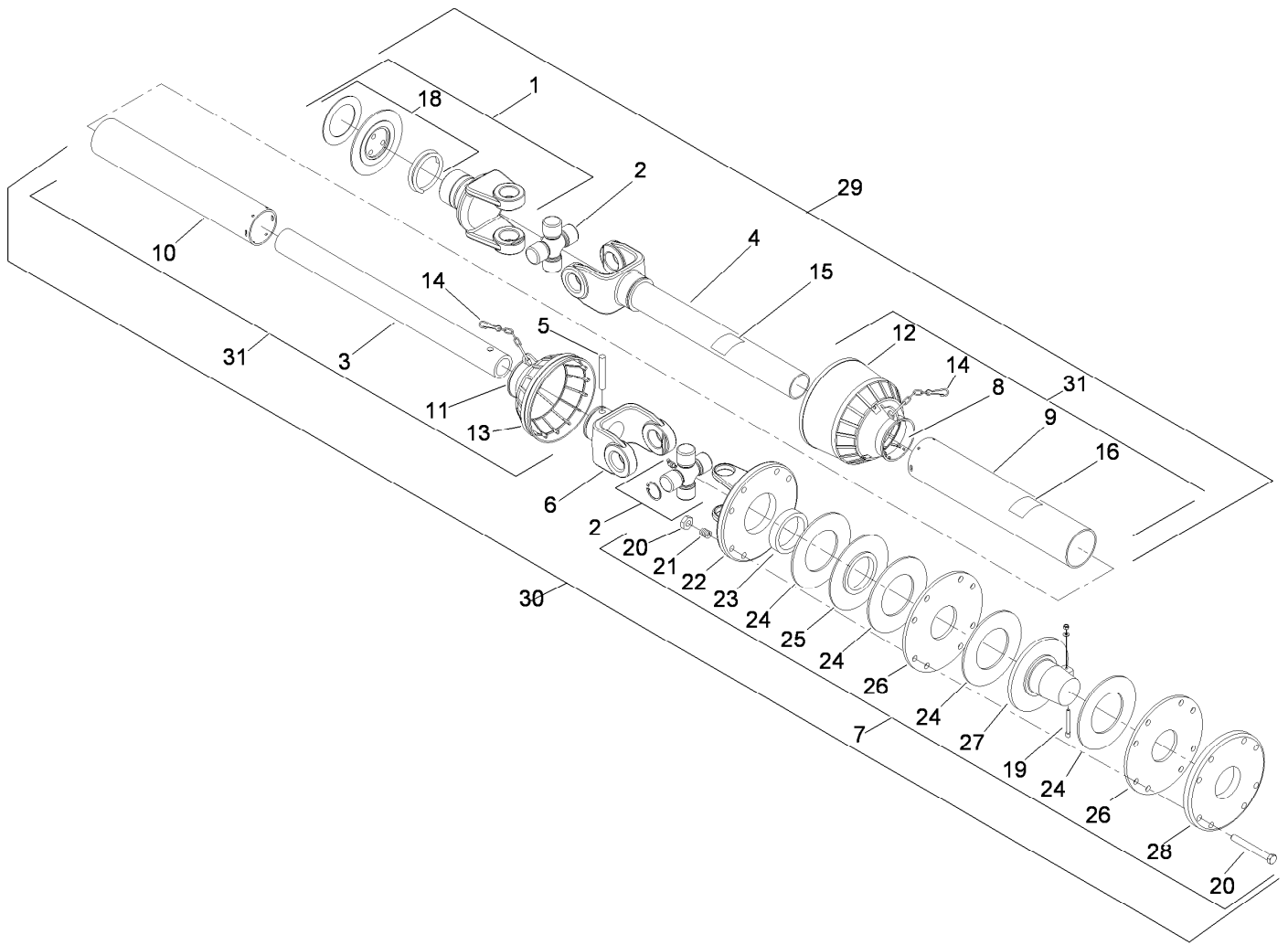

PTO Shaft Assembly No. SG528016

Ref.	Part Number	Qty.	Description	Ref.	Part Number	Qty.	Description
1	119-3152	1	Yoke W/ Ball Collar	17	119-3116	1	Booklet-Instruction, Usa ●
2	119-3153	2	Cross Kit	18	119-3117	1	Ball And Collar Kit
3		1	Tube-Inner, #6 ■	19	119-3163	1	PTO Wedge Bolted ASM
4		1	Tube & Yoke # 6 ■	20	119-3164	8	Bolt And Nut
5	119-3156	1	Pin-Roll, PTO # 7	21	119-3120	8	Spring
6		1	Yoke-Inner Tube ■	22		1	Yoke-Flange ■
7	119-3158	1	Clutch ASM	23		1	Bushing ■
8		1	Support-PTO Shield ■	24	119-3123	4	Plate-Clutch
9		1	Tube-Safety ■	25	119-3166	1	Plate-Driving
10		1	Tube-Safety ■	26	119-3125	2	Plate-Pressure
11		1	Support-PTO Shield ■	27		1	Hub-Splined, PTO #8 ■
12		1	Yoke-Flange ■	28	119-3126	1	Plate-Pressure, PTO
13		1	Hub ■	29	119-3178	1	Half Shaft
14	119-3113	2	Chain-Safety	30	119-3179	1	Half Shaft
15	119-3114	1	Decal-Danger	31	119-3180	1	Shield ASM
16	119-3115	1	Decal-Danger				

● Not illustrated

■ Not serviced separately

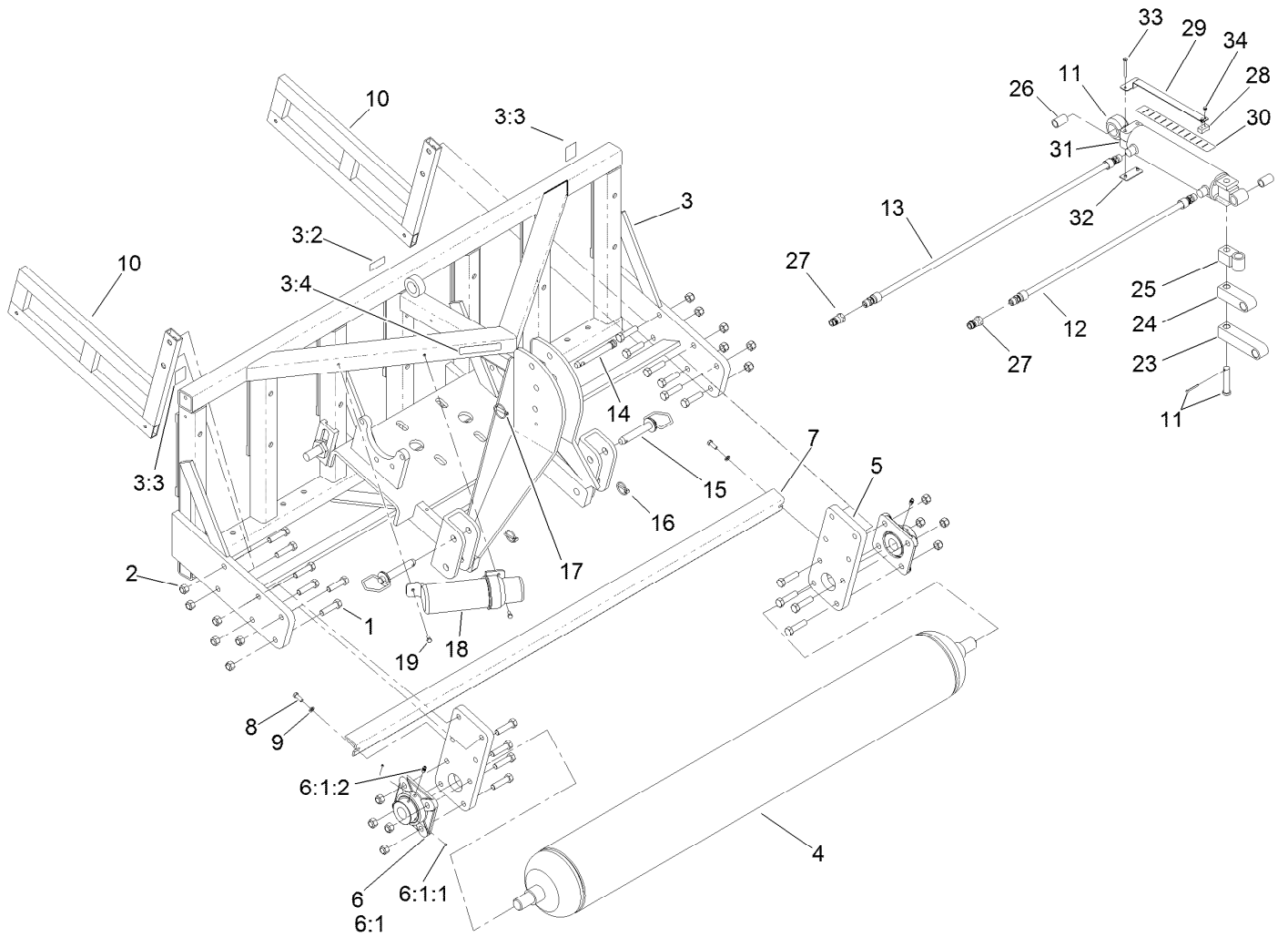

Frame and Roller Assembly

Ref.	Part Number	Qty.	Description	Ref.	Part Number	Qty.	Description
1	3214-9	20	Screw-HH	13	SG795250	1	Hose ASM (Long)
2	3296-41	20	Nut-Lock NI	14	SG715450	1	Pin-Link, Top
3	120-1073	1	Frame ASM	15	112-4378	2	Pin-Hitch
3:2	117-7052	1	Decal-No Oil	16	92-1298	2	Pin-Lynch
3:3	100-3612	2	Decal-Warning	17	100-5389	1	Pin-Lynch
3:4	110-4668	1	Decal-Warning, PTO	18	SG999018	1	Canister-Manual, Operators
4	SG616061-03	1	Roller-Main	19	322-3	2	Screw-HH
5	SG625048-01	2	Bar-Roller, Vertical	23	SG795551-03	1	Extension-Adapter, 5.50 Inch
6	SG631150-03	2	Bearing-Roller	24	SG795554-03	1	Extension-Adapter, 3.50 Inch
6:1		1	Bearing-Flange ●	25	117-7124-03	1	Mount-Adapter, 90 DEG
6:1:1	106-9662	2	Screw-Set, HSH	26	SG555013	2	Bushing
6:1:2	302-19	1	Fitting-Grease	27	120-1032	2	Fitting-HYD
7	SG616725-03	1	Bar-Scraper	28	121-2189	1	Block-Slide
8	323-6	2	Screw-HH	29	121-6918-01	1	Gauge-Depth
9	3253-21	2	Washer-Lock	30	121-6926	1	Decal-Depth
10	SG785150-03	2	Stand-Storage	31	121-6949	1	Clamp-Tube
11	SG715010	1	HYD Cylinder ASM				
12	SG795245	1	Hose ASM (Short)				

● Not serviced separately

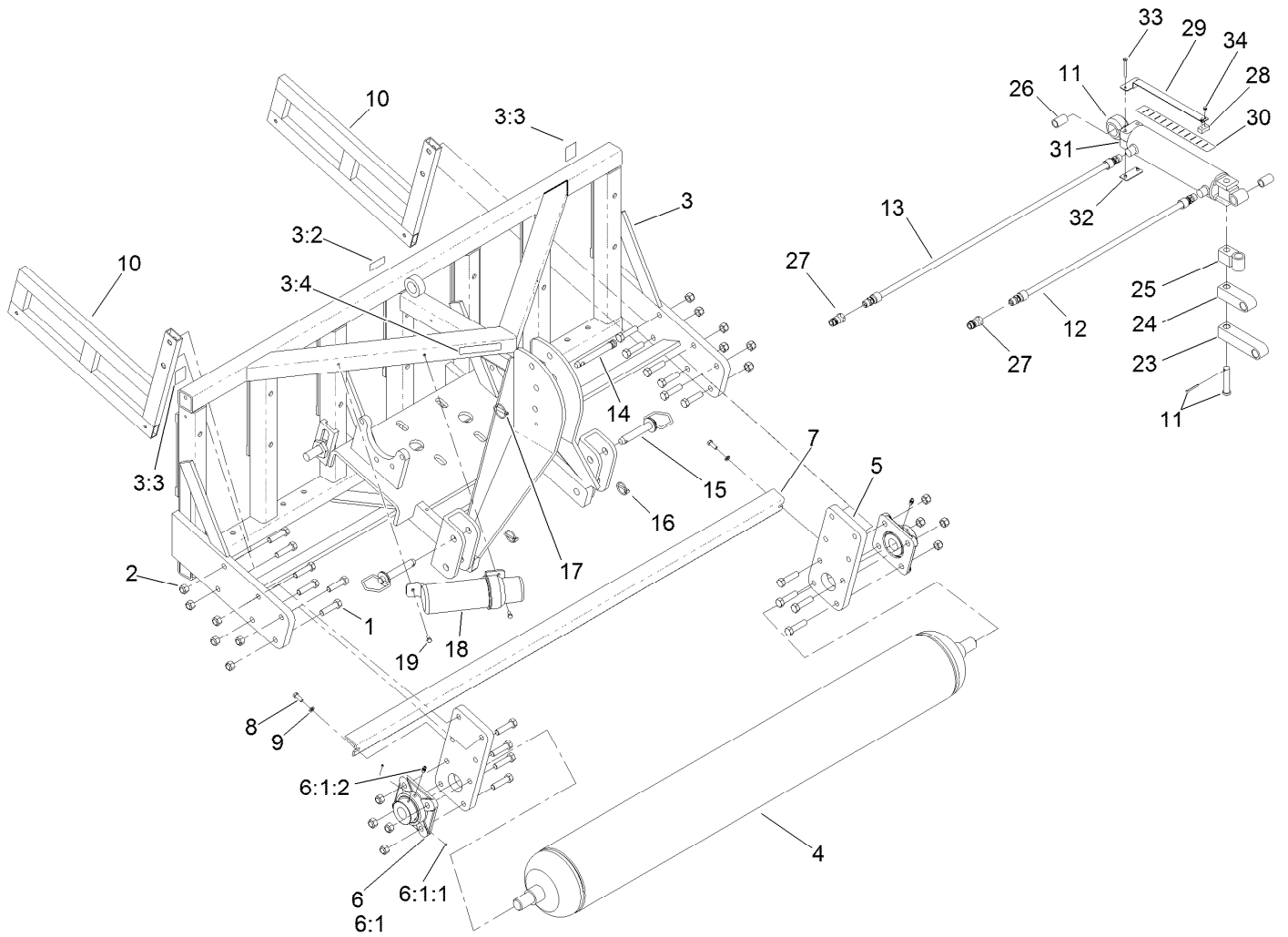

Frame and Roller Assembly (continued)

<i>Ref.</i>	<i>Part Number</i>	<i>Qty.</i>	<i>Description</i>	<i>Ref.</i>	<i>Part Number</i>	<i>Qty.</i>	<i>Description</i>
32	125-3301	1	Plate-Weld	33	321-15	2	Screw-HH
				34	3290-321	2	Screw-HWH

● Not serviced separately

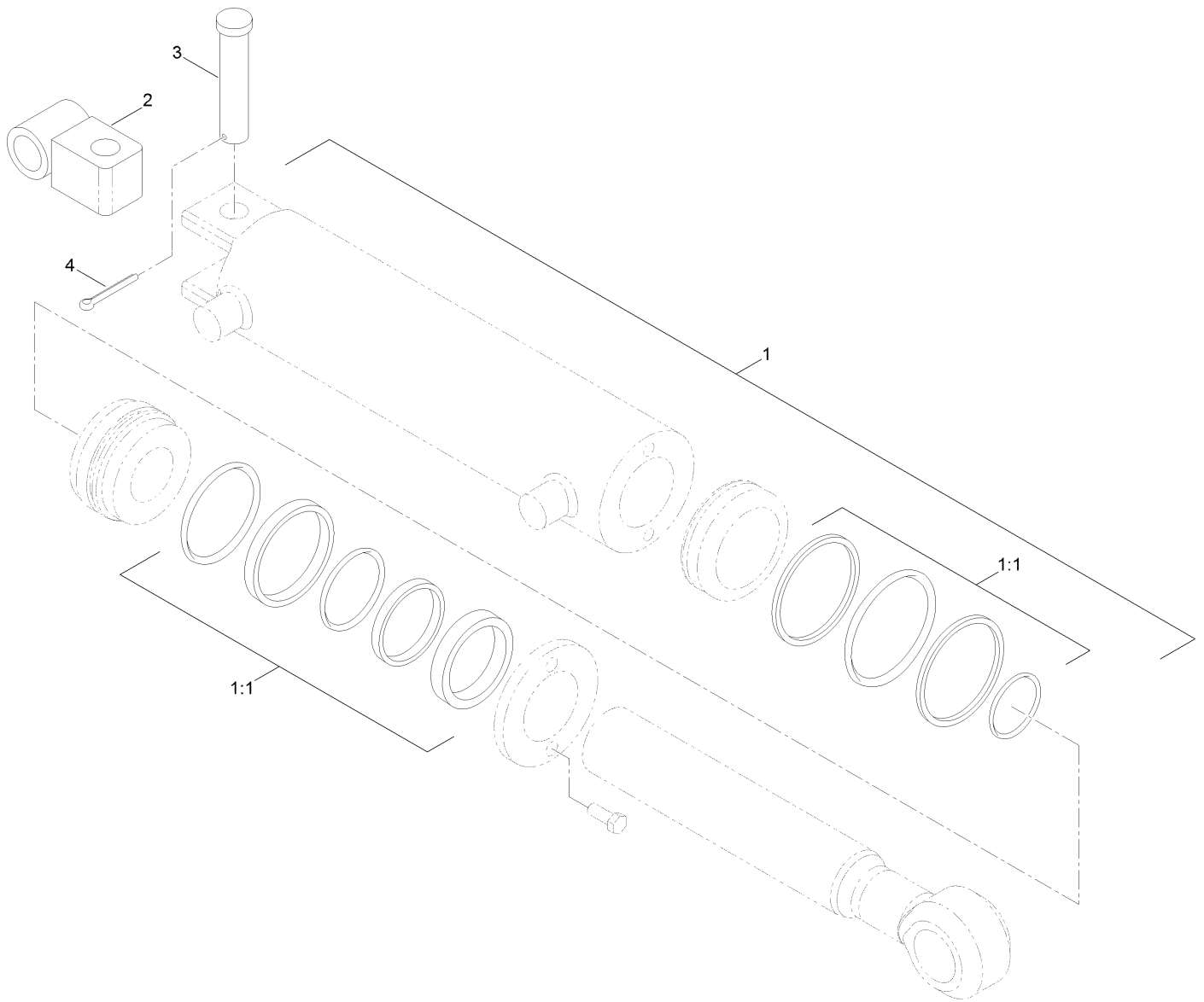

Hydraulic Cylinder Assembly SG715010

<i>Ref.</i>	<i>Part Number</i>	<i>Qty.</i>	<i>Description</i>
1		1	Cylinder-HYD ●
1:1	117-7175	1	Seal Kit
2	117-7182-03	1	Pivot-End, Cylinder
3	108-2800	1	Pin-Clevis
4	3272-23	1	Pin-Cotter

● Not serviced separately

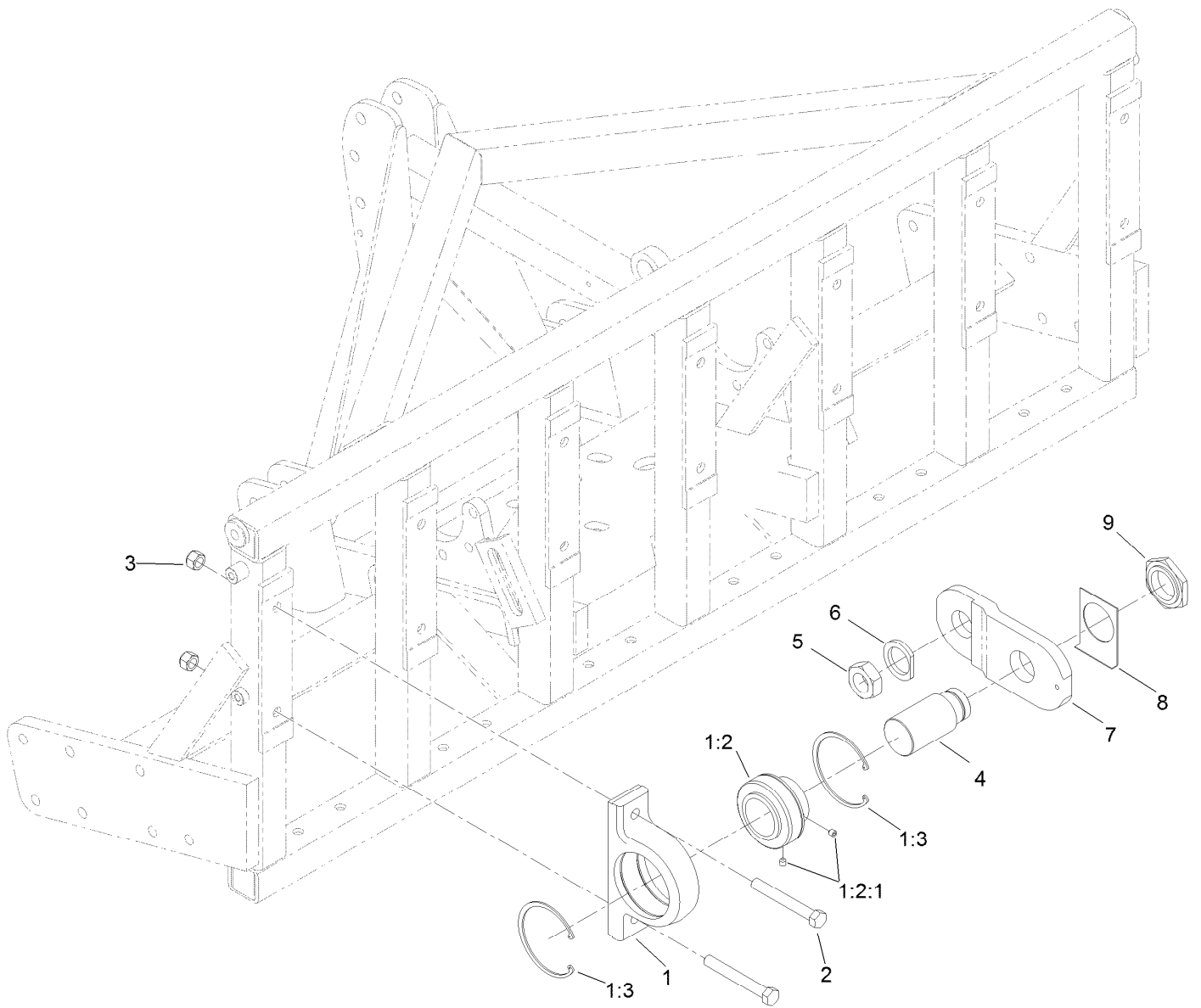

LH Outside Crankshaft Assembly

Ref.	Part Number	Qty.	Description
1	121-6906	1	Main Bearing Housing ASM
1:2		1	Bearing-Ball ●
1:2:1	99-0195	2	Screw-Set, HSH
1:3	SG232433	2	Ring-Snap
2	SG278625	2	Screw-HH
3	3296-41	2	Nut-Lock NI
4	SG211557	1	Shaft-Stub, Outside
5	SG361375	1	Nut-HJ
6	SG241753	1	Washer-Crank, Clipped
7	SG215000-03	1	Arm-Crank
8	SG281240	1	Plate-Locking
9	SG261535	1	Nut-Hex

● Not serviced separately

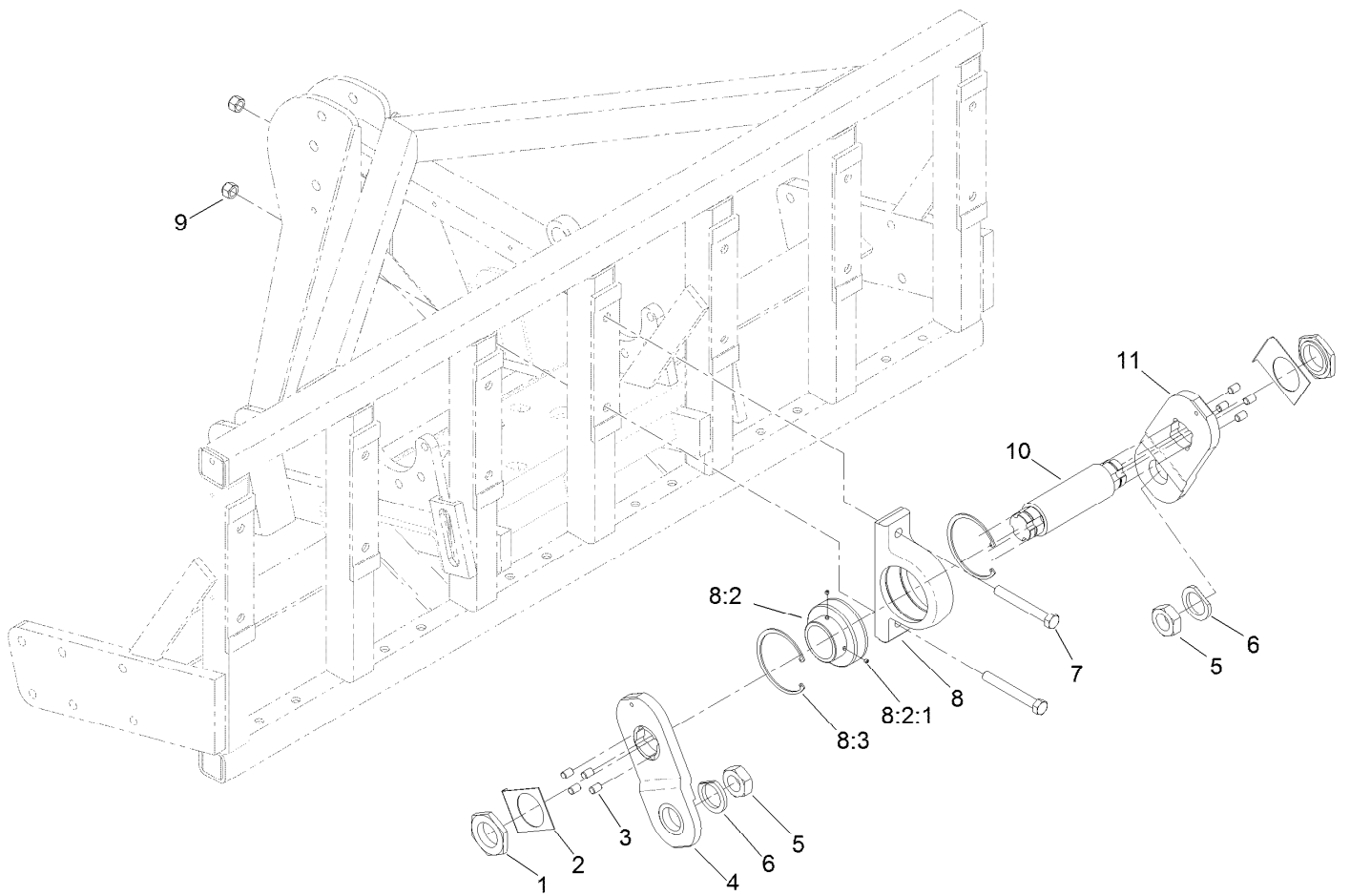

Center Crankshaft Assembly

Ref.	Part Number	Qty.	Description
1	SG261535	2	Nut-Hex
2	SG281240	2	Plate-Locking
3	SG250875	8	Pin-Dowel
4	SG210500-03	1	Arm-Crank
5	SG361375	2	Nut-HJ
6	SG241753	2	Washer-Crank, Clipped
7	SG278625	2	Screw-HH
8	121-6906	1	Main Bearing Housing ASM
8:2		1	Bearing-Ball ●
8:2:1	99-0195	2	Screw-Set, HSH
8:3	SG232433	2	Ring-Snap
9	3296-41	2	Nut-Lock NI
10	SG216500	1	Shaft-Crank
11	SG211500-03	1	Arm-Crank, RH (1/2" Drive)

● Not serviced separately

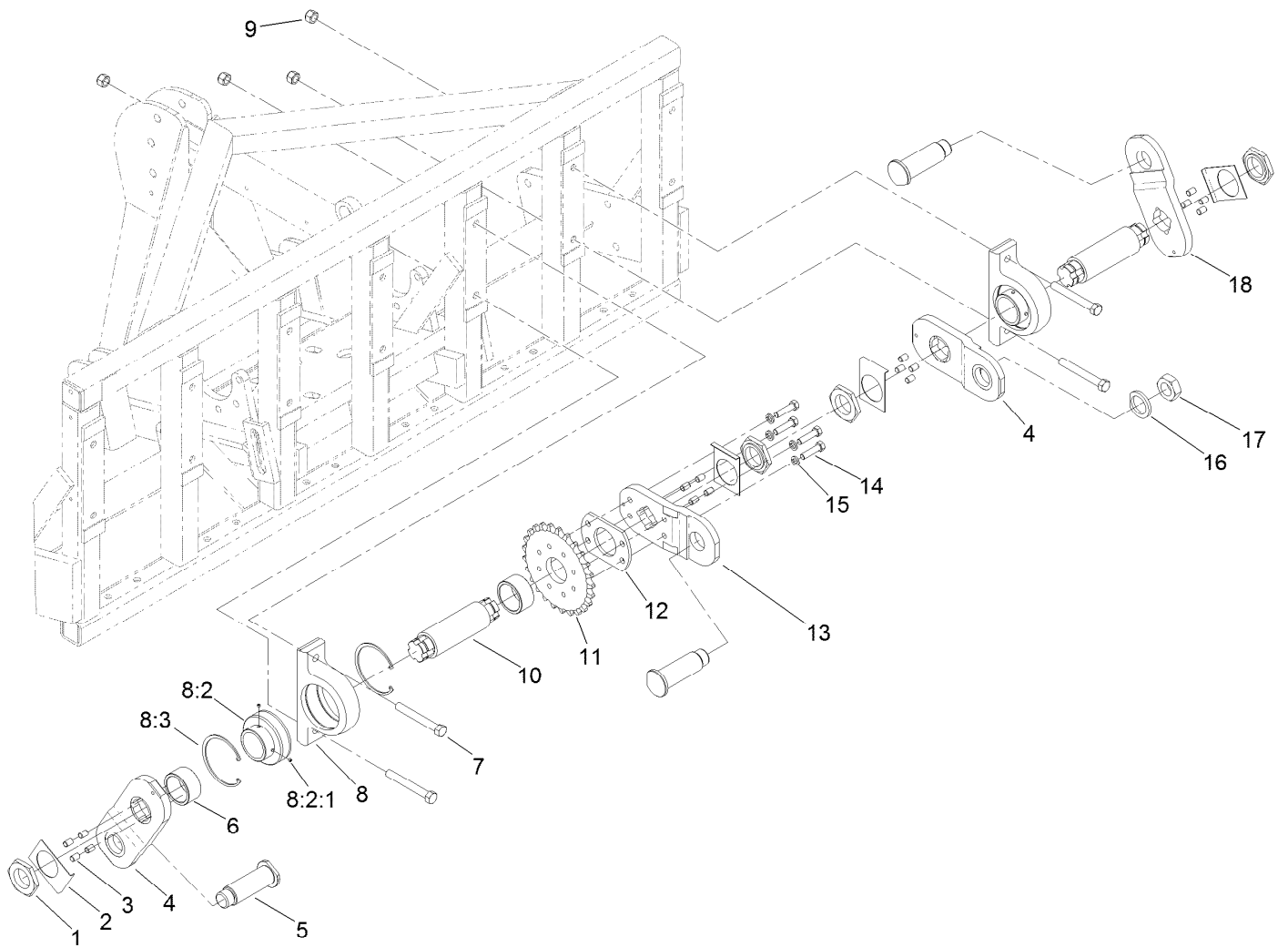

RH Crankshaft Assembly

Ref.	Part Number	Qty.	Description	Ref.	Part Number	Qty.	Description
1	SG261535	4	Nut-Hex	9	3296-41	4	Nut-Lock NI
2	SG281240	4	Plate-Locking	10	SG216500	2	Shaft-Crank
3	SG250875	16	Pin-Dowel	11	SG214025	1	Sprocket-Bore, Plain
4	SG211500-03	2	Arm-Crank, RH (1/2" Drive)	12	SG243300	1	Spacer-Sprocket
5	SG315750	3	Pin-Crank	13	SG200500-03	1	Arm-Crank (1/2" Drive)
6	SG234149	2	Spacer-Tube	14	SG271517	4	Screw-HH
7	SG278625	4	Screw-HH	15	3253-7	4	Washer-Lock
8	121-6906	2	Main Bearing Housing ASM	16	SG241753	1	Washer-Crank, Clipped
8:2		1	Bearing-Ball ●	17	SG361375	1	Nut-HJ
8:2:1	99-0195	2	Screw-Set, HSH	18	SG210500-03	1	Arm-Crank
8:3	SG232433	2	Ring-Snap				

● Not serviced separately

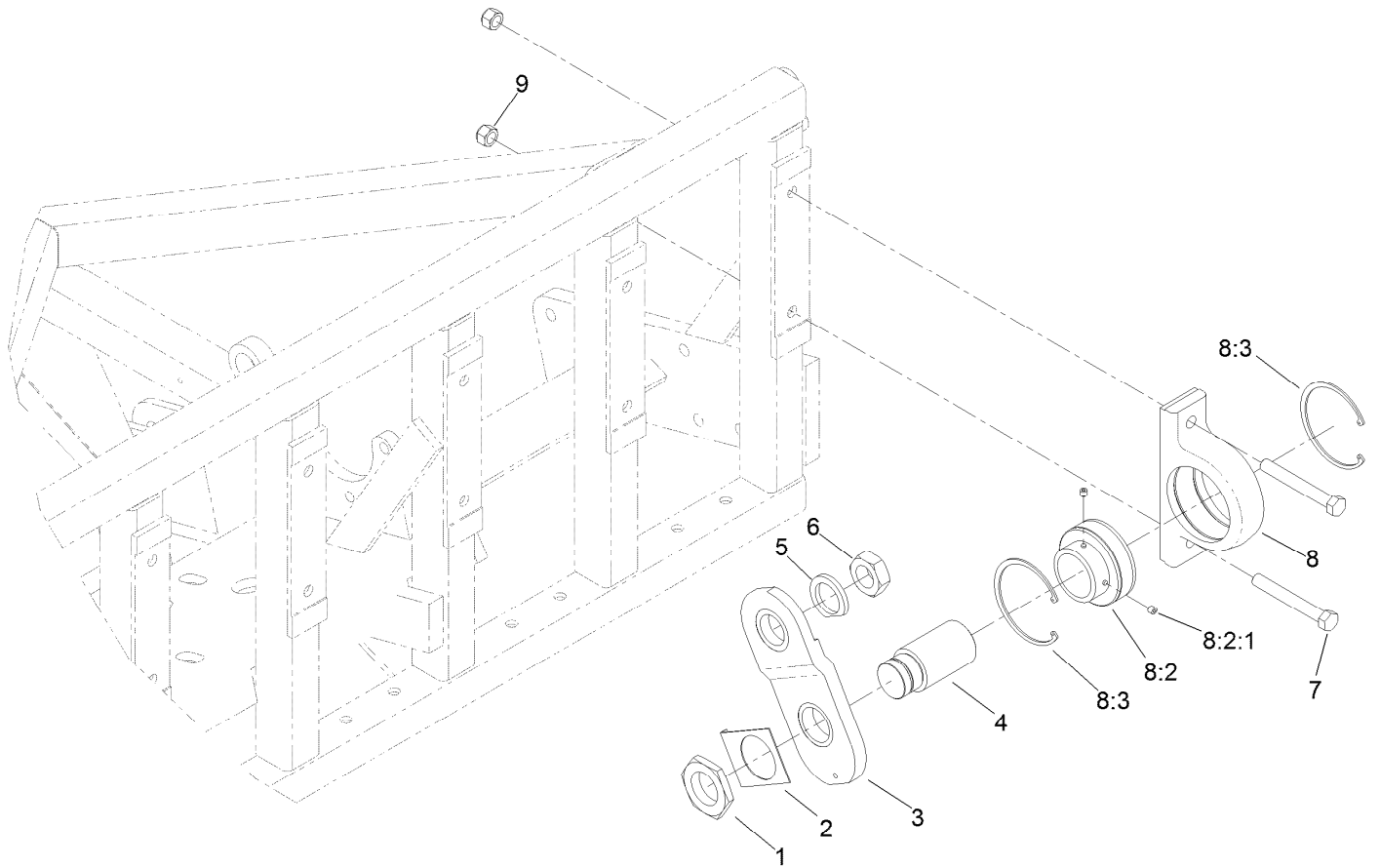

RH Outside Crankshaft Assembly

Ref.	Part Number	Qty.	Description
1	SG261535	1	Nut-Hex
2	SG281240	1	Plate-Locking
3	SG215000-03	1	Arm-Crank
4	SG211557	1	Shaft-Stub, Outside
5	SG241753	1	Washer-Crank, Clipped
6	SG361375	1	Nut-HJ
7	SG278625	2	Screw-HH
8	121-6906	1	Main Bearing Housing ASM
8:2		1	Bearing-Ball ●
8:2:1	99-0195	2	Screw-Set, HSH
8:3	SG232433	2	Ring-Snap
9	3296-41	2	Nut-Lock NI

● Not serviced separately

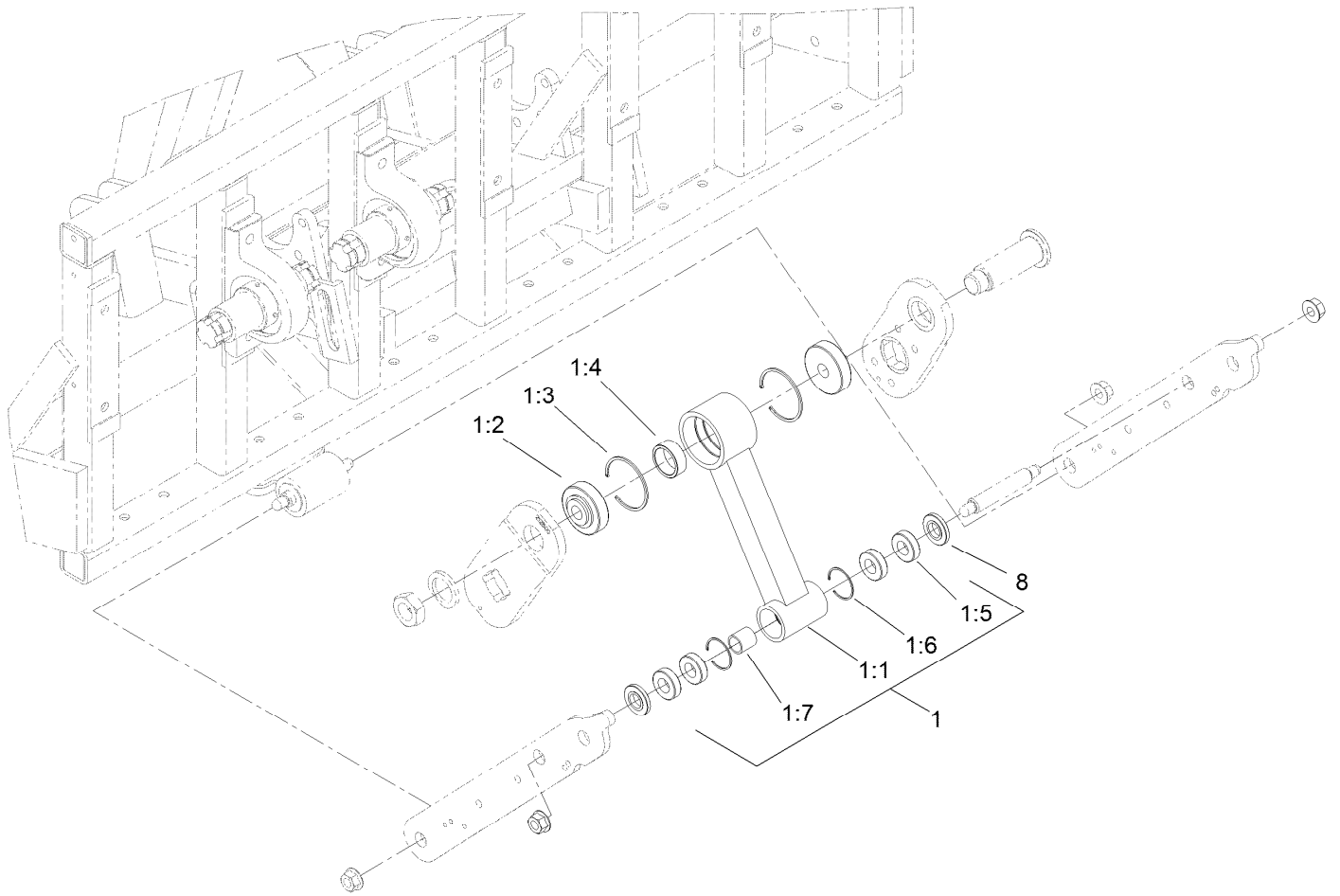

Connecting Rod Assembly

Ref.	Part Number	Qty.	Description
1	SG134125	6	Stomper Arm ASM
1:1		1	Arm-Stomper ●
1:2	SG331112	2	Bearing-Rod, Connecting
1:3	SG332334	2	Ring-Snap
1:4	SG340700	1	Spacer-Rod, Connecting
1:5	SG431012	4	Bearing-Ball
1:6	32120-65	2	Ring-Snap
1:7	SG410290	1	Bushing-Inner
8	SG441240	12	Bushing-Outer

● Not serviced separately

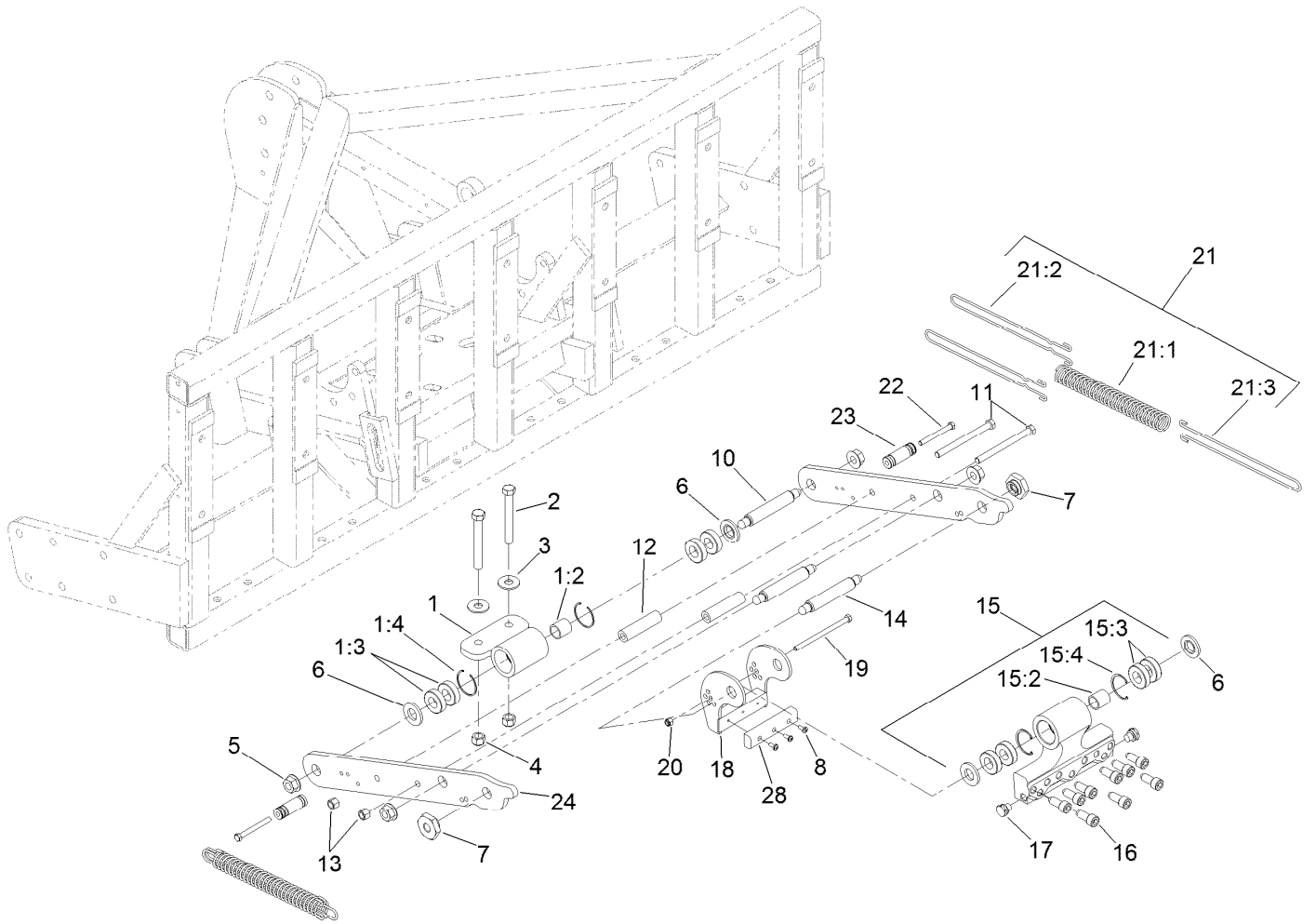

Lower Arm and Hinge Assembly

Ref.	Part Number	Qty.	Description	Ref.	Part Number	Qty.	Description
1	SG142000	6	Hinge ASM	15:2	SG410290	1	Bushing-Inner
1:2	SG410290	1	Bushing-Inner	15:3	32120-65	2	Ring-Snap
1:3	SG431012	4	Bearing-Ball	15:4	SG431012	4	Bearing-Ball
1:4	32120-65	2	Ring-Snap	16	SG471620	54	Head-Tine, Bolt (Long)
2	3214-15	12	Screw-HH	17	SG483125	12	Holder-Spring, Front
3	3256-7	12	Washer-Flat	18	120-7267-03	6	Bracket-Camber
4	3296-41	12	Nut-Lock NI	19	323-26	6	Screw-HH
5	32128-53	24	Nut-HF	20	3296-39	6	Nut-Lock, NI
6	SG441240	24	Bushing-Outer	21	SG148160	12	Spring ASM
7	120-7271	12	Nut-HH	21:1	SG481512	1	Spring-Compression
8	3290-145	18	Screw	21:2	SG482016	2	Wire-Bar, Draw
10	SG410500	12	Pin-Wrist, Short	21:3	SG482017	1	Wire-Bar, Draw
11	325-20	12	Screw-HH	22	323-15	12	Screw-HH
12	SG434118	12	Spacer-Arm, Linkage	23	SG484351-03	12	Post-Spring, Rear
13	3296-23	12	Nut-Lock, NI	24	SG434117-03	12	Arm-Linkage
14	SG410437	6	Pin-Wrist, Head	28	119-0952	6	Pad-Bumper
15	125-3339	9	Bolt Tine Head ASM				

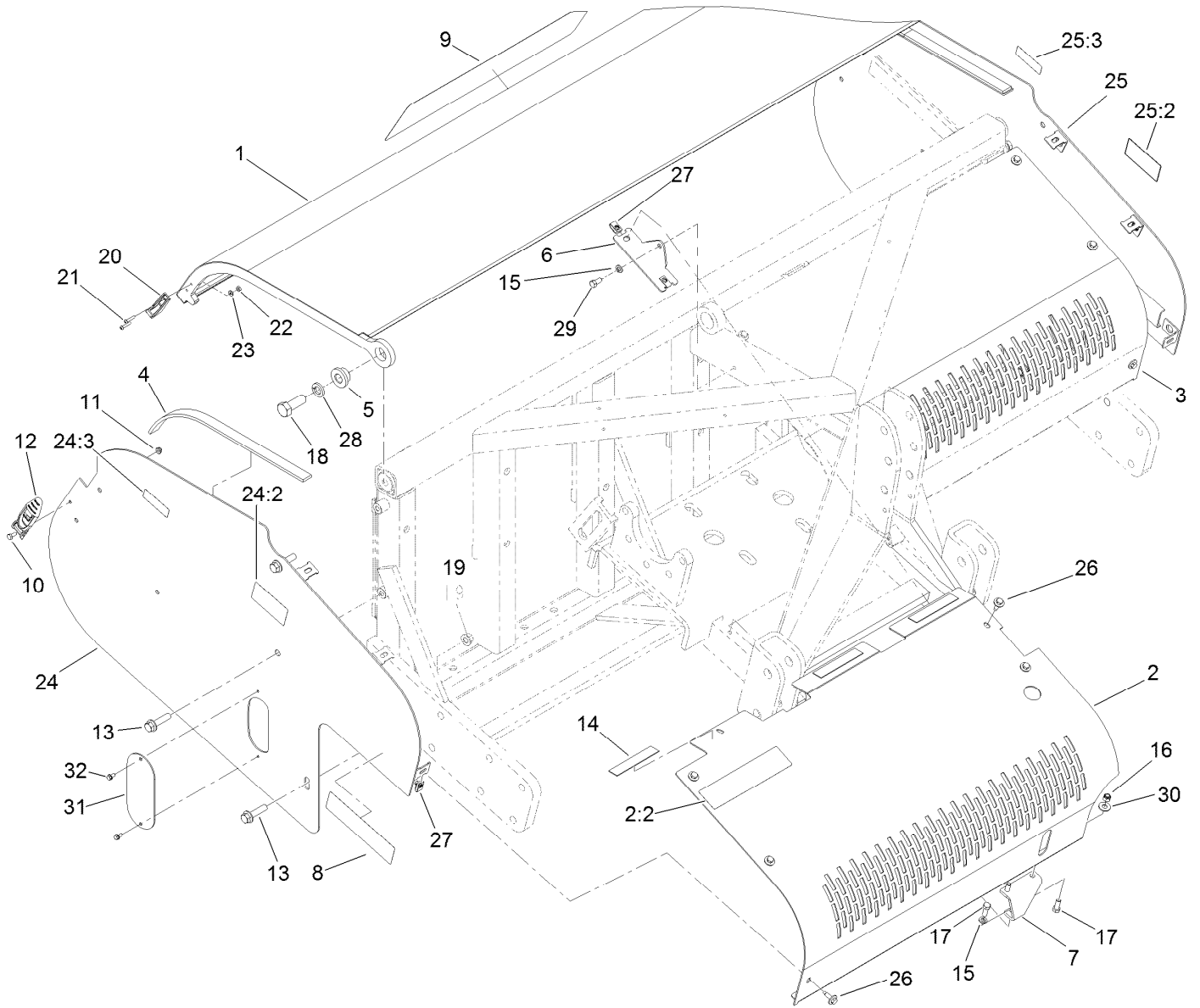

Cover Assembly

Ref.	Part Number	Qty.	Description	Ref.	Part Number	Qty.	Description
1	119-3261-03	1	Hood	20	103-2897	2	Latch-Catch
2	120-1079	1	Front Right Guard ASM	21	108-3153	4	Screw-HSBH
2:2	117-7050	1	Decal-Warning, Ce	22	3296-2	4	Nut-Lock, NI
3	117-7153-03	1	Guard-Front, LH	23	3256-14	4	Washer-Flat
4	120-7273	2	Strip-Rubber	24	120-1077	1	RH Shield ASM
5	120-1021	2	Bushing-Hood	24:2	117-7051	1	Decal-Danger, Keep Away Ce
6	120-7294-03	2	Bracket-Guard, Front	24:3	120-0625	1	Decal-Warning, Pinch Point
7	120-7297-03	2	Bracket-Screen, Front	25	120-1078	1	LH Shield ASM
8	117-7087	2	Decal	25:2	117-7051	1	Decal-Danger, Keep Away Ce
9	117-7058	1	Decal	25:3	120-0625	1	Decal-Warning, Pinch Point
10	321-3	2	Screw-HH	26	114-8418	10	Screw-HWH, Sems
11	104-7201	2	Nut-HF	27	94-2413	10	U-Nut
12	103-2898	2	Latch-Rubber	28	3253-9	2	Washer-Lock
13	3234-27	6	Screw-HHF	29	323-4	2	Screw-HH
14	120-1087	6	Strip-Rubber	30	3256-4	4	Washer-Flat
15	3253-21	4	Washer-Lock	31	119-0956-03	2	Plate-Cover
16	3296-39	4	Nut-Lock, NI	32	32144-4	2	Screw-HWH
17	323-6	6	Screw-HH				
18	328-24	2	Screw-HH				
19	99-5107	2	Nut-Lock				

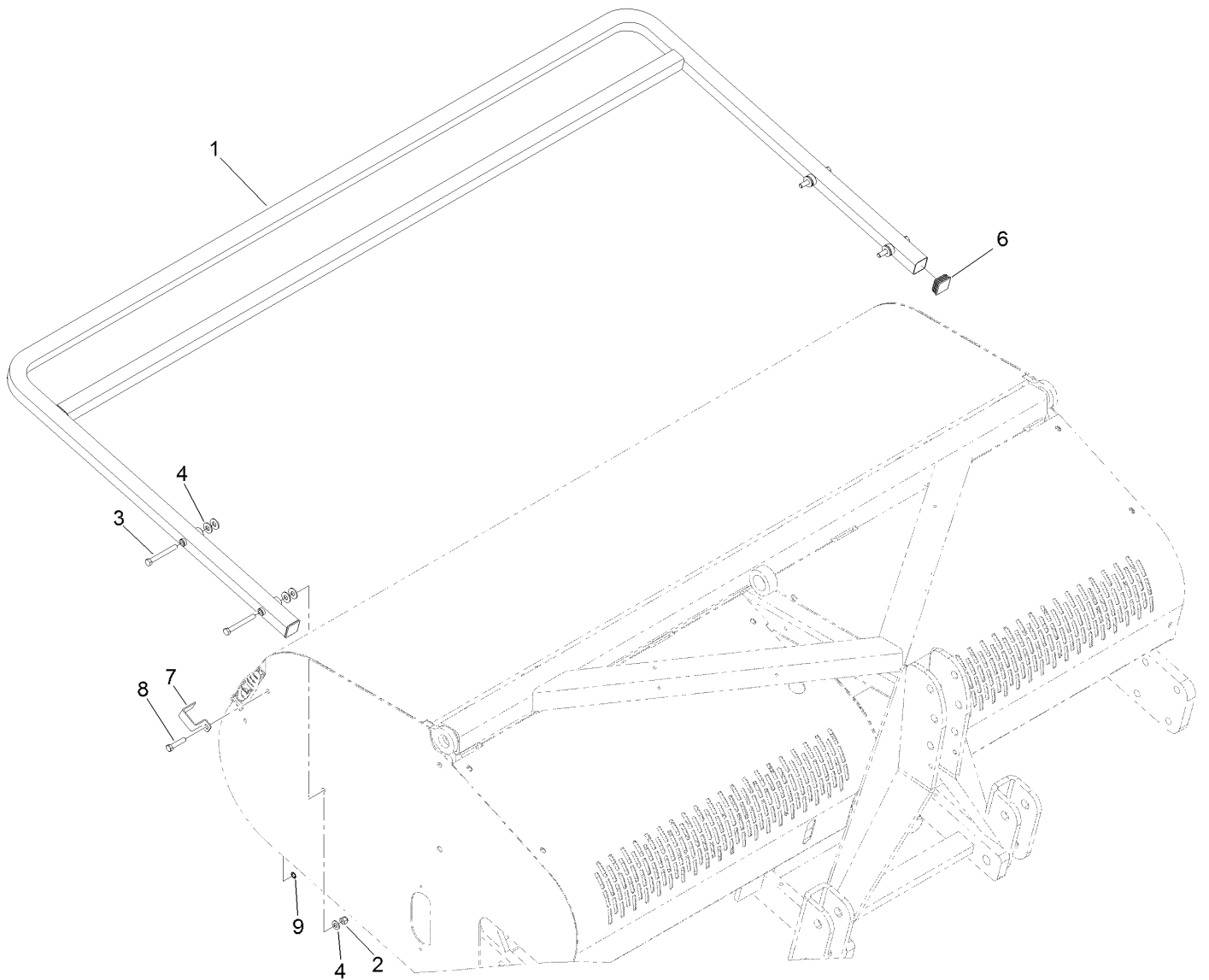

Rear Guard Assembly

<i>Ref.</i>	<i>Part Number</i>	<i>Qty.</i>	<i>Description</i>
1	119-3275-03	1	Guard-Rear
2	3296-39	4	Nut-Lock, NI
3	323-20	4	Screw-HH
4	80-6990	12	Washer-Hardened
6	120-7261	2	Cap-End, Square
7	110-4673	2	Lock-Latch, Ce
8	323-53	2	Screw-HH
9	32151-72	2	Ring-Retaining

Attachments and Accessories

For 09935 ProCore SR72 Aerator

Product Name	Model/Part
Rear Roller Kit	09954
10 x 5/16in Tine Head Adapter Kit.....	117-7190
10 x 12mm Tine Head Adapter Kit	117-7191
Adapter Sleeve 5/16 x 8in	SGA08313
Adapter Sleeve	SGA12375



Count on it.