



**Count on it.**

**Parts Catalog**

**Z Master® Commercial 2000  
Series Riding Mower**

**with 60in TURBO FORCE® Side Discharge  
Mower**

Model No. 74145—Serial No. 314000001 and Up



# Ordering Replacement Parts

To order replacement parts, please supply the part number, the quantity, and the description of each part desired.

## Understanding Reference Numbers

Each identified part in an illustration has a reference number. The reference number for a part also appears in the parts list, along with other information about the part.

This catalog uses two special reference number formats, one to indicate parts in a service assembly and another to indicate the quantity of a given part in an illustration.

## Service Assembly Reference Numbers

Parts in service assemblies have reference numbers in the form a:b. The a represents the reference number of the entire service assembly and the b represents a sequential number unique to each part within the service assembly.

For example, a wheel assembly might be identified by reference number 6, the tire by 6:1, the valve by 6:2, and the wheel by 6:3. When you order the assembly identified by reference number 6, you receive all parts identified by reference numbers 6:1, 6:2, and 6:3. However, you may also order any part individually. Reference numbers of this type appear in illustration and in parts lists.

## Reference Numbers Indicating Quantity

In an illustration, if a reference number indicates more than one part, the reference number has the form nX y. The n represents the quantity of the part, the X is the multiplication symbol, and the y represents the reference number.

For example, in an illustration, the reference number 2X 37 means that two of the parts identified by reference number 37 are indicated.

# List of Abbreviations

**AR:** as required

**ASM:** assembly

**BBC:** blade brake control

**BHTF:** button head thread forming

**CARR:** carriage

**CCW:** counter clockwise

**CW:** clockwise

**DEG:** degrees

**DPA:** Dual Point Adjustment

**ECM:** electronic control module

**EXT:** external

**FH:** flat head

**GA:** gauge

**HD:** heavy-duty

**HF:** hex flange

**HH:** hex head

**HHF:** hex head flange

**HHFTF:** hex head flange thread forming

**HJ:** hex jam

**HLH:** hex lag head

**HOC:** height-of-cut

**HSBH:** hex socket button head

**HSFH:** hex socket flat head

**HSH:** hex socket head

**HWH:** hex washer head

**HWHTF:** hex washer head thread forming

**HYD:** hydraulic

**LH:** left hand

**LP:** Liquefied Petroleum Gas

**LPG:** Liquefied Petroleum Gas

**NI:** nylon insert

**NPTF:** national pipe thread fine

**PFH:** phillips flat head

**PPH:** phillips pan head

**PPHTF:** phillips pan head thread forming

**PRH:** phillips round head

**PTH:** phillips truss head

**PTO:** power-take-off

**RH:** right hand

**ROPS:** roll-over protection system

**RRB:** rear roller brush

**SFH:** slotted fillister head

**SHH:** slotted hex head

**SHWH:** slotted hex washer head

**SPH:** slotted pan head

**SQH:** square head

**SRH:** slotted round head

**STD:** standard

**TAP:** self tapping

**TTH:** torx truss head

# Contents

Frame and Caster Wheel Assembly .....	4
Roll-Over Protection System Assembly No. 116-0231 .....	6
Caster Wheel and Fork Assembly .....	8
Hydro Drive System Assembly .....	10
Hydro Idler Arm Assembly .....	12
Fuel Tank and Hose Assembly .....	14
Seat Mounting Assembly .....	16
Seat Assembly No. 127-9538 .....	18
Motion Control Assembly .....	20
Parking Brake Assembly .....	22
Engine, Muffler and Control Panel Assembly .....	24
Deck Lift Assembly .....	26
Height-of-Cut Assembly No. 120-2530 .....	28
Deck Assembly .....	30
Deck Decal Assembly No. 120-2461 .....	32
Deflector Assembly No. 120-2451 .....	34
Idler Assembly .....	36
Electrical Assembly .....	38
Attachments and Accessories .....	40

# Frame and Caster Wheel Assembly

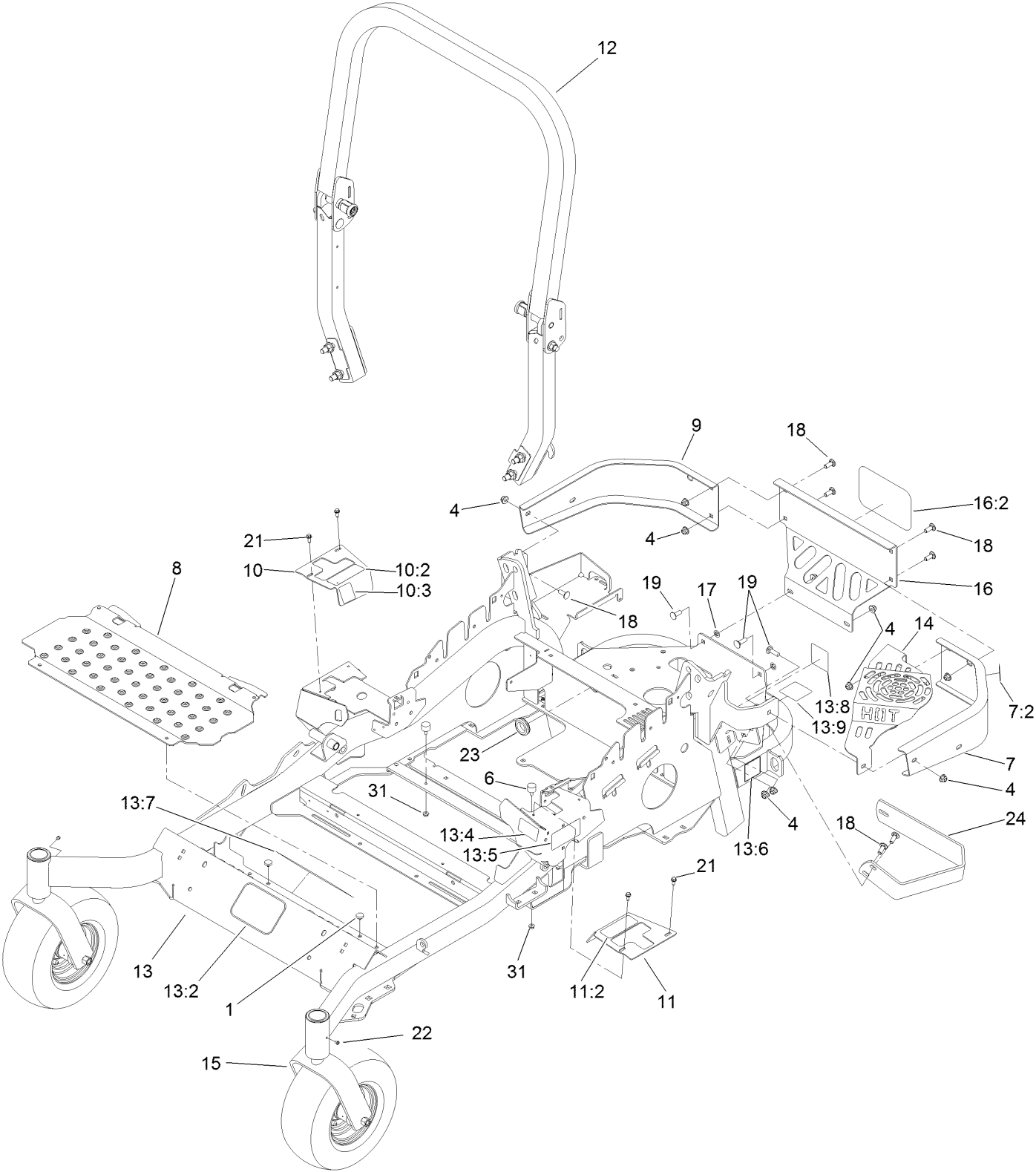

## Frame and Caster Wheel Assembly (continued)

<i>Ref.</i>	<i>Part Number</i>	<i>Qty.</i>	<i>Description</i>	<i>Ref.</i>	<i>Part Number</i>	<i>Qty.</i>	<i>Description</i>
1	1-513658	2	Bumper	13:6	116-0205	2	Decal-Belt Drive
4	104-8301	10	Nut-Flange, NI	13:7	116-3303	1	Decal-Slope
6	116-6380	2	Bumper-Rubber (W/ Stud)	13:8	116-4858	1	Decal-Spark Arrester
7	109-9869	1	Bumper-Rear, LH	13:9	117-1158	2	Decal-Bypass
7:2	103-2076	1	Decal-Caution	14	120-7896-03	1	Guard-Muffler
8	116-8898-01	1	Floorpan	15		2	Caster Wheel ASM ●
9	116-0508-03	1	Bumper-Rear, RH	16	119-2691	1	Rear Guard ASM
10	120-3280	1	Cover ASM-Motion Control	16:2	67-7320	1	Decal
10:2	109-7232	1	Decal-Motion Control	17	107-3154	2	Nut-Push
10:3	116-5944	1	Decal-Park Brake	18	3231-22	7	Screw-CARR
11	120-3279	1	Cover ASM-Motion Control	19	3231-25	3	Bolt-CARR
11:2	109-7232	1	Decal-Motion Control	21	32144-10	4	Screw-HWH
12	116-0231	1	ROPS ASM	22	1-811010	2	Plug
13	117-8591	1	Frame ASM	23	120-3265	1	Grommet
13:2	68-3640	1	Decal	24	119-2607-03	1	Guard-Muffler, Side
13:4	116-1654	1	Decal-Fuel Fill	31	104-7201	2	Nut-HF
13:5	120-5891	2	Decal				

● Not serviced separately

# Roll-Over Protection System Assembly No. 116-0231

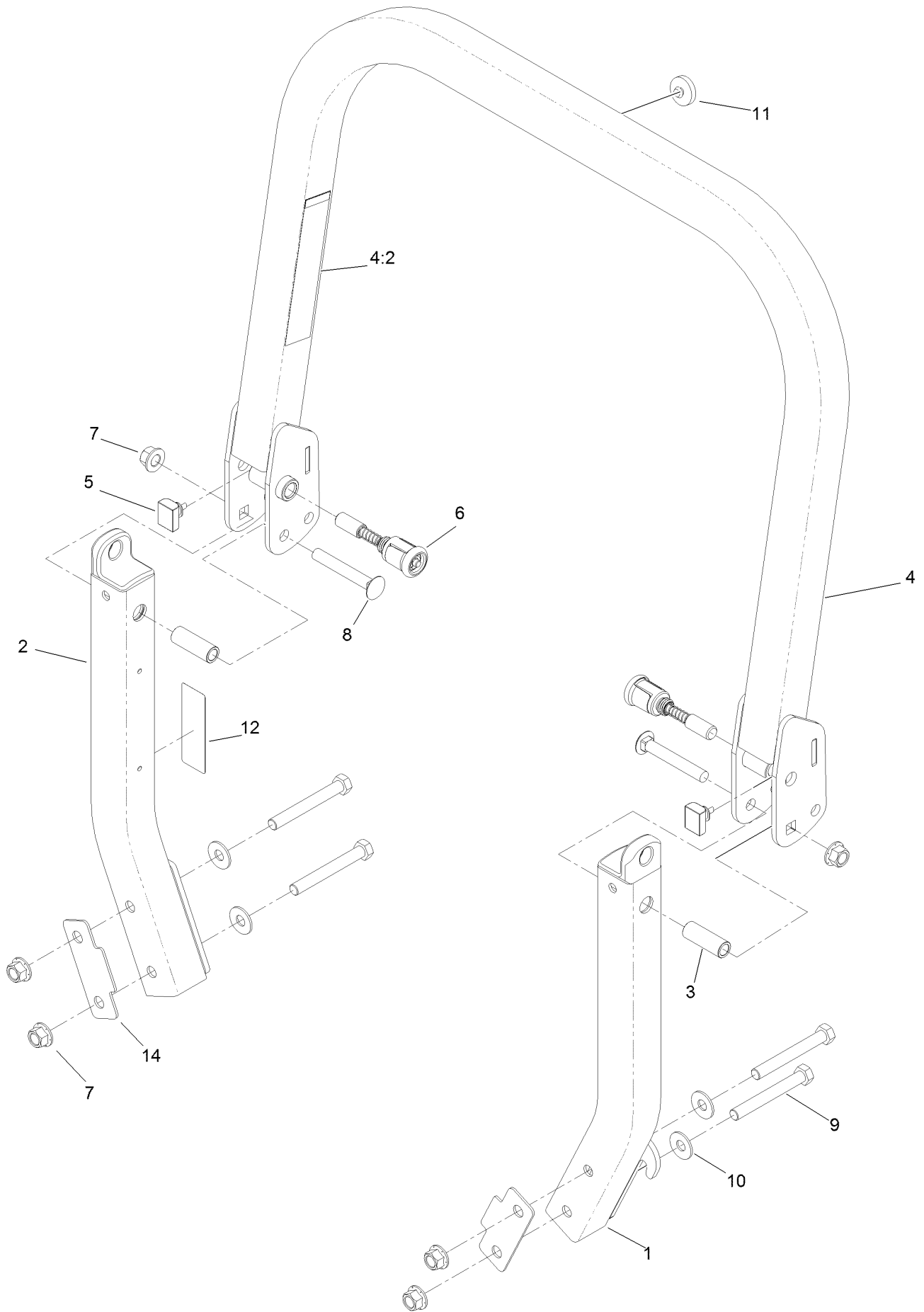

# Roll-Over Protection System Assembly No. 116-0231 (continued)

<i>Ref.</i>	<i>Part Number</i>	<i>Qty.</i>	<i>Description</i>	<i>Ref.</i>	<i>Part Number</i>	<i>Qty.</i>	<i>Description</i>
1		1	Leg-ROPS, LH ●	7	99-5107	6	Nut-Lock
2		1	Leg-ROPS, RH ●	8	3233-10	2	Screw-CARR
3	109-6653	2	Spacer	9	325-17	4	Screw-HH
4		1	Upper ROPS ASM ●	10	109-9505	4	Washer-Spring
4:2	107-2102	1	Decal-Warning, Folding ROPS	11	109-9233	1	Bumper-Push-In, Rubber
5	109-5337	2	Bumper-ROPS	12	116-0090	1	Decal-Caution
6	116-0104	2	Pin-Spring	14	116-0960	2	Spacer

● Not serviced separately

# Caster Wheel and Fork Assembly

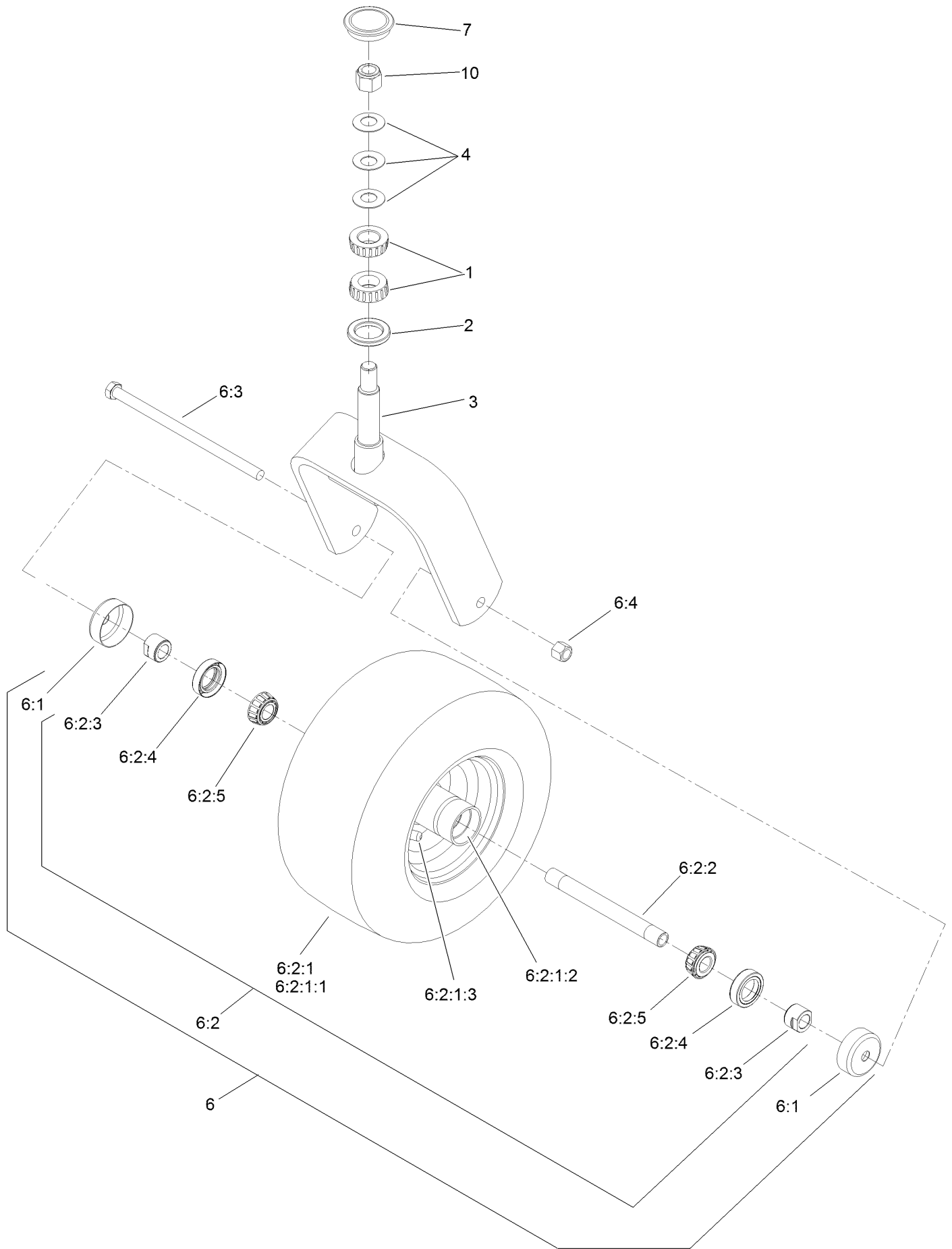

## Caster Wheel and Fork Assembly (continued)

<i>Ref.</i>	<i>Part Number</i>	<i>Qty.</i>	<i>Description</i>	<i>Ref.</i>	<i>Part Number</i>	<i>Qty.</i>	<i>Description</i>
1	1-543509	2	Bearing-Roller, Tapered	6:2:1:3	5108	1	Valve
2	116-5647	1	Seal-Grease	6:2:2	103-5156	1	Axle-Caster
3	116-6707-01	1	Caster	6:2:3	103-3051	2	Spacer-Nut
4	1-633508	3	Washer-Bellville	6:2:4	103-0063	2	Seal-Caster
6	127-9540	1	Wheel And Axle ASM	6:2:5	1-633585	2	Bearing-Cone, Taper
6:1	103-2768	2	Guard-Seal	6:3	325-39	1	Screw-HH
6:2		1	Wheel And Bearing ASM ●	6:4	3296-23	1	Nut-Lock, NI
6:2:1		1	Wheel And Tire ASM ●	7	103-4882	1	Cap-Grease
6:2:1:1	1-523009	1	Tire	10	3296-51	1	Nut-Lock, NI
6:2:1:2	1-633584	2	Bearing-Cup				

● Not serviced separately

# Hydro Drive System Assembly

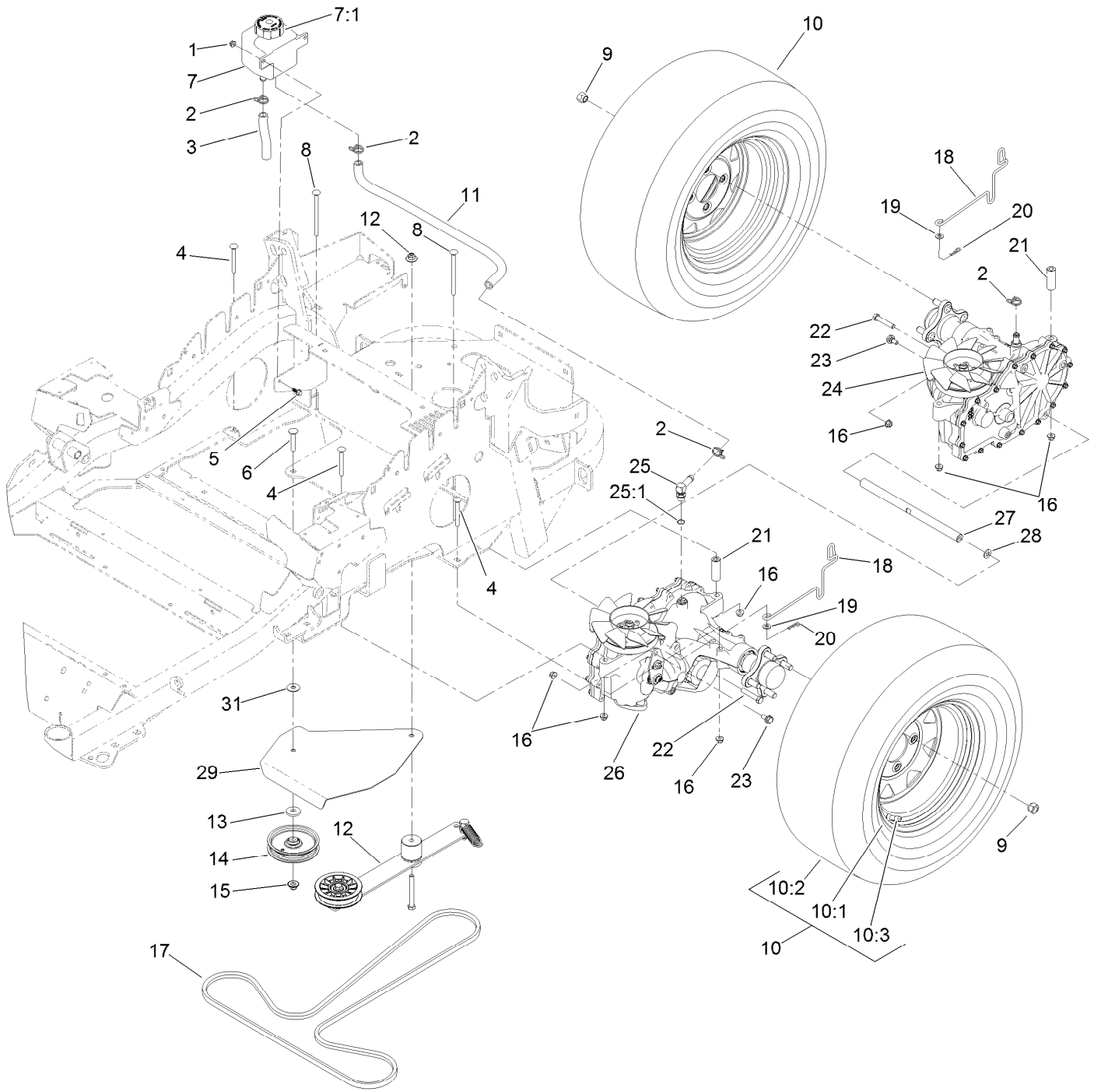

## Hydro Drive System Assembly (continued)

<i>Ref.</i>	<i>Part Number</i>	<i>Qty.</i>	<i>Description</i>	<i>Ref.</i>	<i>Part Number</i>	<i>Qty.</i>	<i>Description</i>
1	104-7201	2	Nut-HF	15	109-6658	1	Nut-Flange, NI
2	117-1193	4	Clamp-Hose	16	104-8300	10	Nut-Flange, NI
3	119-2642	1	Hose-HYD	17	114860	1	Belt-V
4	3230-9	6	Screw-CARR	18	125-8950	2	Rod-Bypass
5	99-6810	2	Screw-HHF	19	3256-23	2	Washer-Flat
6	117-9971	1	Bolt-Carriage	20	1-806003	2	Pin-Cotter, Hair
7	109-2250	1	Vent-Tank, Hydro	21	109-3652	2	Spacer-Hydro
7:1	109-3320	1	Cap-Reservoir, HYD	22	94-7972	2	Screw-HH W/Loctite
8	3230-30	2	Screw-CARR	23	37-8771	2	Bolt-Shoulder
9	242-50	8	Nut-Lug	24	130-2850	1	RH Transaxle ASM
10	127-9508	2	Wheel And Tire ASM	25	109-6449	1	Fitting-Elbow, 90
10:1	127-9509	1	Wheel	25:1	237-42	1	O-Ring
10:2	120-3269	1	Tire	26	130-2851	1	LH Transaxle ASM
10:3	232-27	1	Stem-Valve	27	117-8585	1	Shaft-Cross, Hydro
11	119-2689	1	Hose-HYD	28	3256-24	1	Washer-Flat
12		1	Hydro Idler Arm ASM ●	29	125-4777-01	1	Plate-Guard
13	1-373034	1	Washer	31	52-2860	1	Washer
14	93-1622	1	Pulley-Idler				

● Not serviced separately

# Hydro Idler Arm Assembly

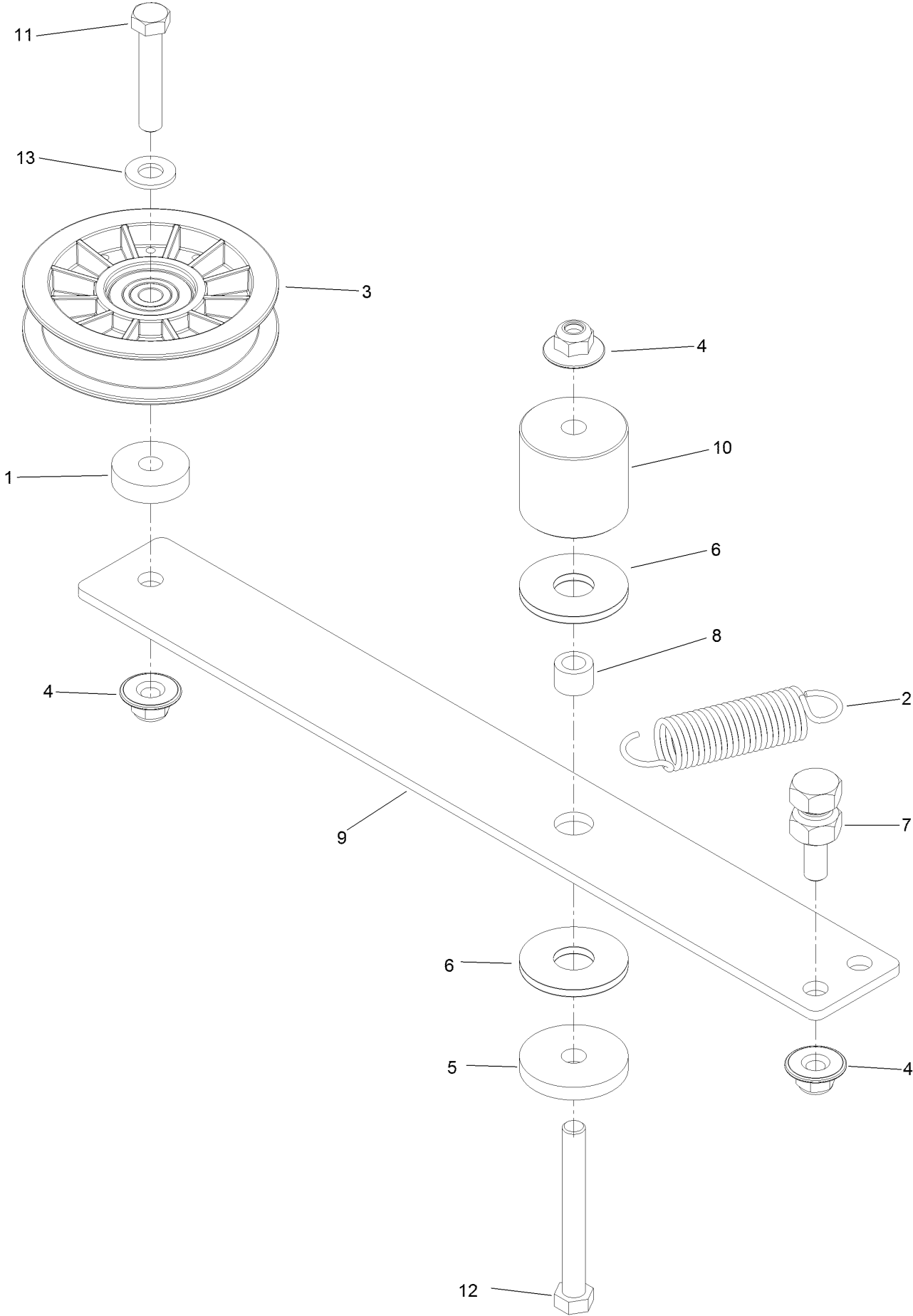

## Hydro Idler Arm Assembly (continued)

<i>Ref.</i>	<i>Part Number</i>	<i>Qty.</i>	<i>Description</i>	<i>Ref.</i>	<i>Part Number</i>	<i>Qty.</i>	<i>Description</i>
1	105-7788	1	Spacer	8	115-4986	1	Spacer
2	108-4056	1	Spring-Extension	9	119-9914	1	Arm-Idler, Hydro
3	109-3397	1	Pulley-Idler, Flat	10	119-2657	1	Spacer-Plain
4	109-6658	3	Nut-Flange, NI	11	323-10	1	Screw-HH
5	110-9981	1	Washer-Plain	12	323-20	1	Screw-HH
6	114-0463	2	Washer-Friction, Composite	13	3256-24	1	Washer-Flat
7	114-5866	1	Anchor-Spring, Short				

# Fuel Tank and Hose Assembly

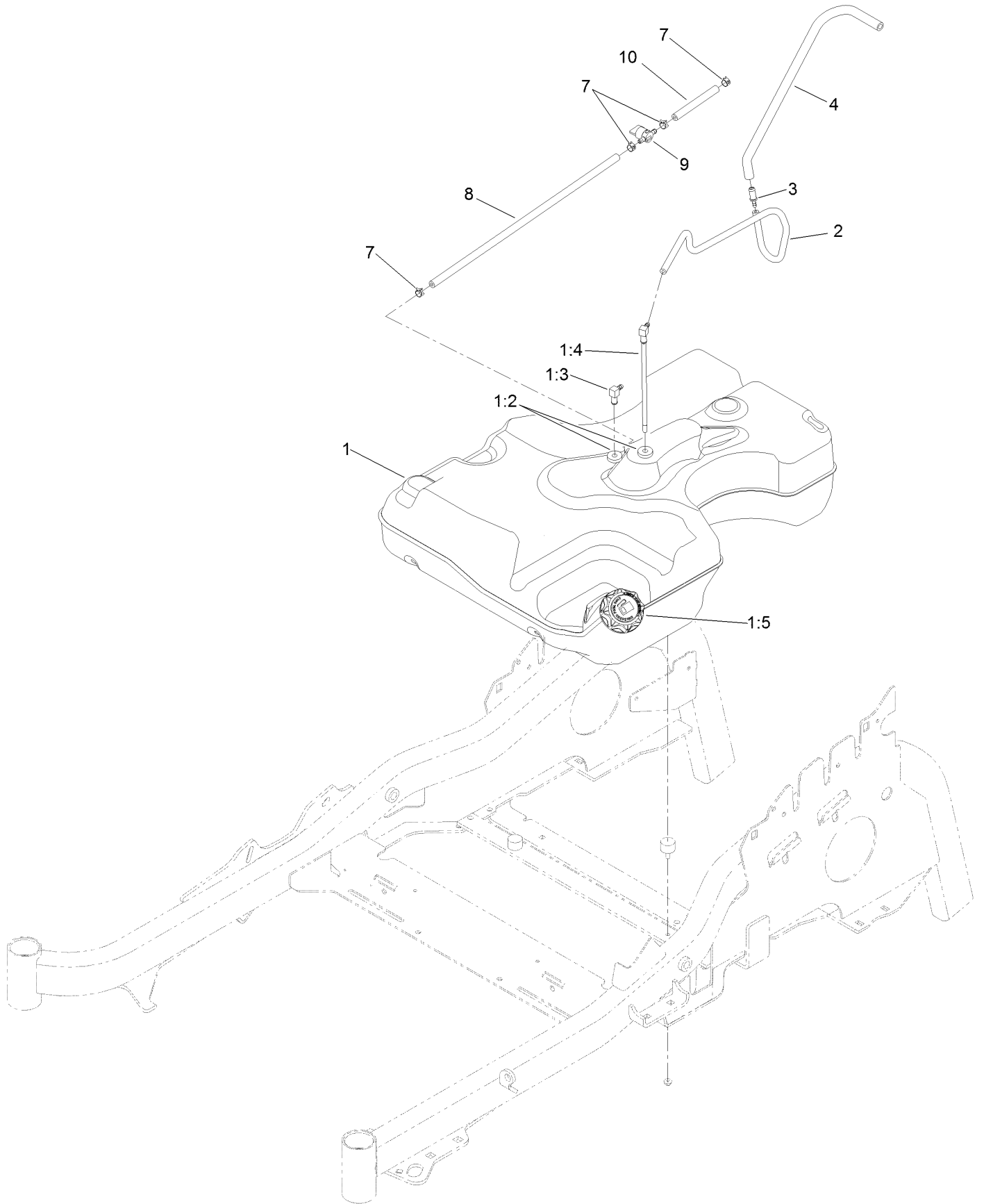

## Fuel Tank and Hose Assembly (continued)

<i>Ref.</i>	<i>Part Number</i>	<i>Qty.</i>	<i>Description</i>	<i>Ref.</i>	<i>Part Number</i>	<i>Qty.</i>	<i>Description</i>
1	125-4765	1	Fuel Tank ASM	3	98-2952	1	Fitting-Straight
1:2	46-6560	2	Bushing	4	119-8562	1	Hose-Fuel
1:3	116-2288	1	Fitting-90 Elbow	7	2412-98	4	Clamp-Hose
1:4	125-4767	1	Fuel Line ASM	8	110-5701	1	Hose-Fuel
1:5	126-1789	1	Cap-Fuel, Ratcheting	9	1-603770	1	Valve-Fuel
2	119-6074	1	Hose-Fuel	10	109-0650	1	Hose-Fuel

# Seat Mounting Assembly

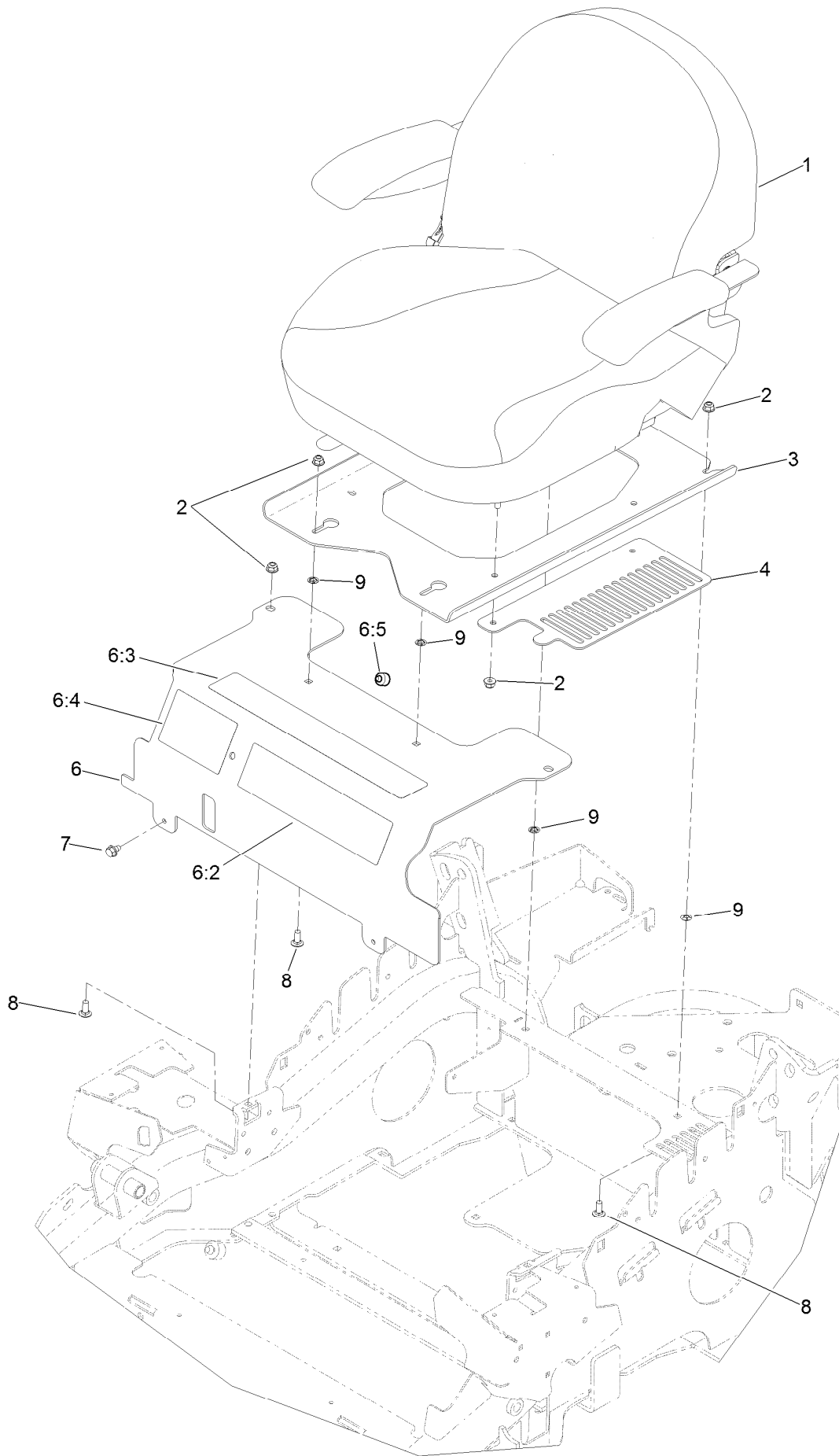

## Seat Mounting Assembly (continued)

<i>Ref.</i>	<i>Part Number</i>	<i>Qty.</i>	<i>Description</i>	<i>Ref.</i>	<i>Part Number</i>	<i>Qty.</i>	<i>Description</i>
1	127-9538	1	Seat ASM	6:3	109-7069	1	Decal-Console
2	104-8300	10	Nut-Flange, NI	6:4	121-3223	1	Decal-Service Aid
3	117-8615-03	1	Plate-Mount, Seat	6:5	120-7893	1	Bumper-Grommet
4	117-8618-03	2	Plate-Cover, Fan	7	9266934	2	Screw
6	119-2597	1	Seat Mount Panel ASM	8	3230-23	6	Screw-CARR
6:2	114-5878	1	Decal	9	117-2749	4	Nut-Push

# Seat Assembly No. 127-9538

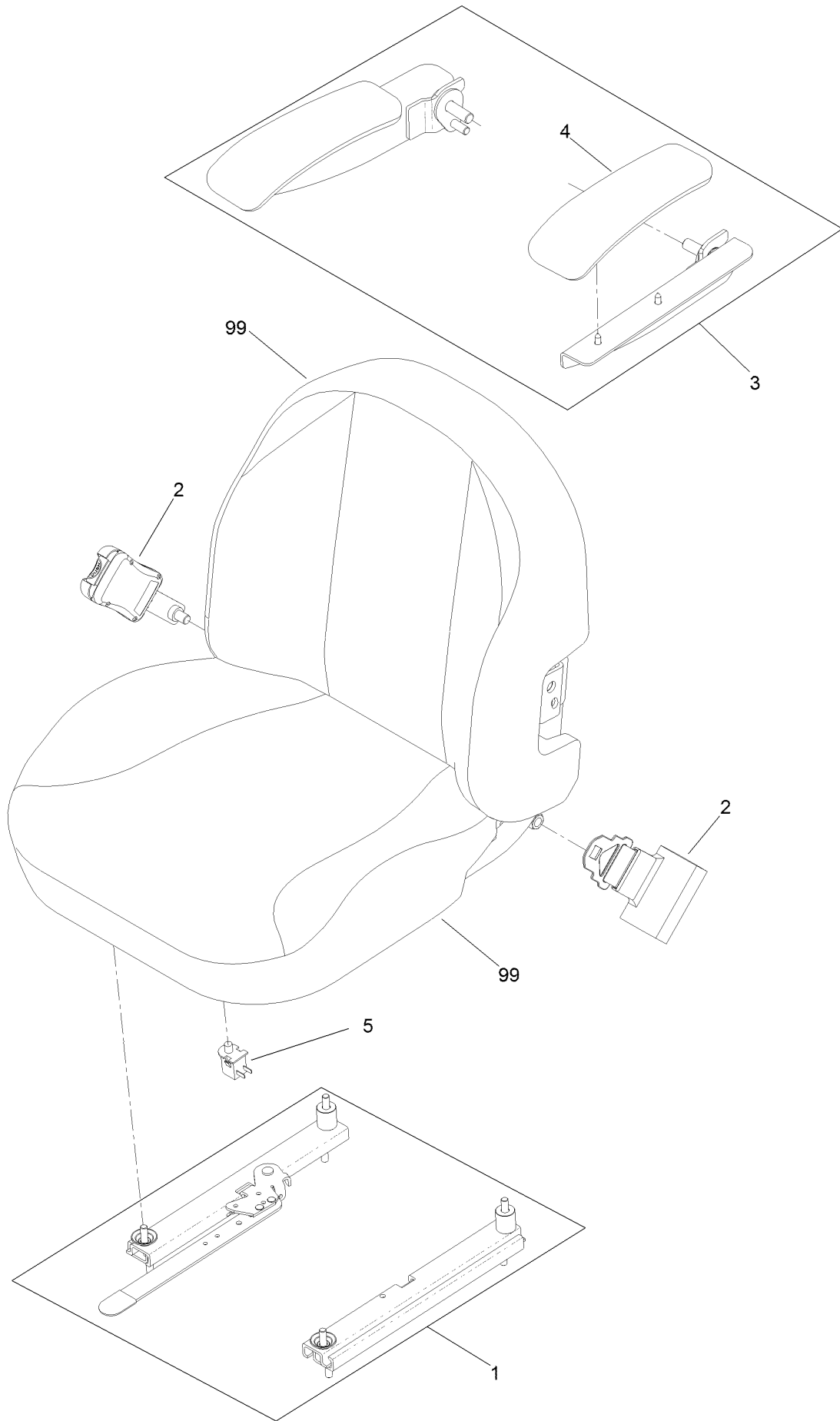

## Seat Assembly No. 127-9538 (continued)

<i>Ref.</i>	<i>Part Number</i>	<i>Qty.</i>	<i>Description</i>	<i>Ref.</i>	<i>Part Number</i>	<i>Qty.</i>	<i>Description</i>
1	130-2853	1	Seat Track Kit	5	82-2190	1	Switch-Bail
2	130-2854	1	Seat Belt Kit	99	130-2855	1	Cover-Seat, Back
3	126-2058	1	Armrest Kit	99	130-2856	1	Cover-Seat, Bottom
4	110-4163	2	Cushion-Rest, Arm				

# Motion Control Assembly

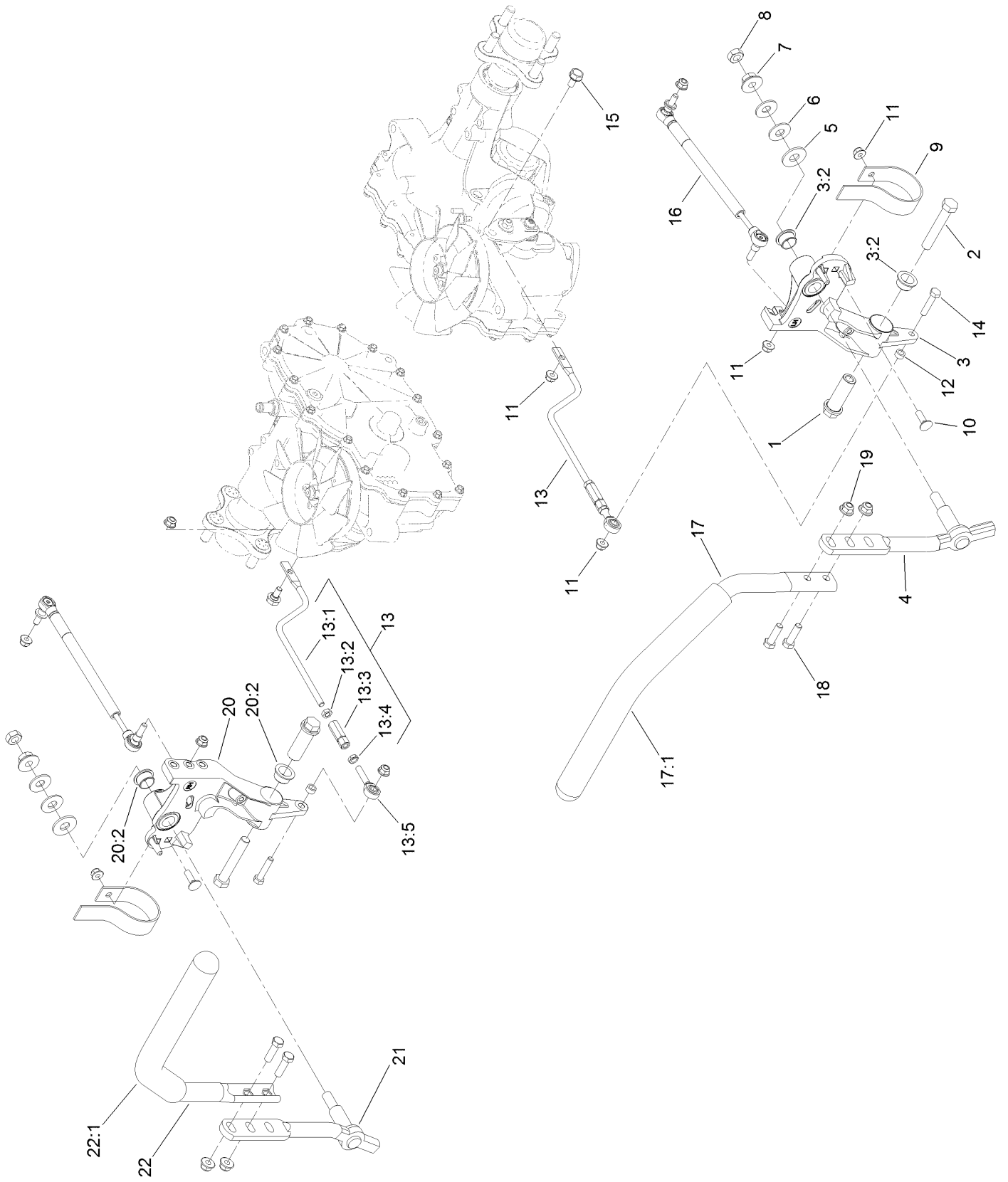

## Motion Control Assembly (continued)

<i>Ref.</i>	<i>Part Number</i>	<i>Qty.</i>	<i>Description</i>	<i>Ref.</i>	<i>Part Number</i>	<i>Qty.</i>	<i>Description</i>
1	109-5891	2	Hub-Threaded	13:3	109-3728	1	Nut-Rod Adjustment
2	325-12	2	Screw-HH	13:4	3220-20	1	Nut-Jam
3	116-0881	1	LH Motion Control And Bushing ASM	13:5	2411-53	1	Bearing-Rod End, LH
3:2	109-8054	4	Bushing-Flange	14	322-7	2	Screw-HH
4	116-0040	1	Lever-Control Motion, LH	15	37-8771	2	Bolt-Shoulder
5	3256-6	2	Washer-Flat	16	116-0027	2	Damper-Control, Motion
6	109-9505	4	Washer-Spring	17	109-6590	1	LH Steering Handle ASM
7	32128-56	2	Nut-HF	17:1	109-5668	1	Grip-Control, Lever
8	3218-5	2	Nut-Jam	18	323-7	4	Screw-HH
9	109-5575	2	Spring-Leaf	19	104-8301	4	Nut-Flange, NI
10	3230-2	2	Bolt-CARR	20	116-0880	1	RH Motion Control And Bushing ASM
11	104-8300	10	Nut-Flange, NI	20:2	109-8054	4	Bushing-Flange
12	92-6998	2	Spacer-Yoke, Right	21	116-0039	1	Lever-Control Motion, RH
13	119-2605	2	Hydro Control Rod ASM	22	109-6589	1	RH Steering Handle ASM
13:1	119-2606	1	Rod-Control, Hydro	22:1	109-5668	1	Grip-Control, Lever
13:2	3220-2	1	Nut-Jam				



## Parking Brake Assembly (continued)

<i>Ref.</i>	<i>Part Number</i>	<i>Qty.</i>	<i>Description</i>	<i>Ref.</i>	<i>Part Number</i>	<i>Qty.</i>	<i>Description</i>
1	121-4766-03	1	Handle-Brake	14:1	121-4770	1	Rod-Brake
2	3296-47	3	Nut-Lock, NI	14:2	1-543017	1	Balljoint-RH
3	322-1	1	Screw-HH	14:3	3219-2	1	Nut-Hex
4	1-633268	1	Grip-Lever	15	323-7	1	Screw-HH
5	1-513140	2	Bearing-Control	16	3256-23	6	Washer-Flat
6	106-9888	1	Washer-Flat	17	3296-4	2	Nut-Lock
7	3272-10	1	Pin-Cotter	18	322-16	2	Screw-HH
8	121-4807	1	Brake Link ASM	19	121-4761-01	1	Bracket-Shaft Mount, RH
8:1	121-4795	1	Rod-Link, Brake	20	121-4793-01	1	Bracket-Shaft Mount, LH
8:2	103-0608	1	Joint-Ball, End	21	1-633102	2	Bearing-Flange, Side
8:3	3219-3	1	Nut-Hex	22	323-4	4	Screw-HH
9	3290-307	1	Pin-Hair	23	104-8301	8	Nut-Flange, NI
10	121-4804-03	1	Shaft-Brake	24	3231-22	3	Screw-CARR
11	32151-48	1	E-Ring	25	3231-28	1	Screw-CARR
12	110769	1	Spring-Extension	26	3256-24	3	Washer-Flat
13	121-4805	1	LH Brake Rod ASM	27	103-5677	2	Spacer
13:1	121-4755	1	Rod-Brake	28	1-603807	2	Spring-Return, Neutral
13:2	1-543017	1	Balljoint-RH	29	3296-59	1	Nut-Lock, NI
13:3	3219-2	1	Nut-Hex	30	114-8450	2	Clip-Retaining
14	121-4806	1	RH Brake Rod ASM				

# Engine, Muffler and Control Panel Assembly

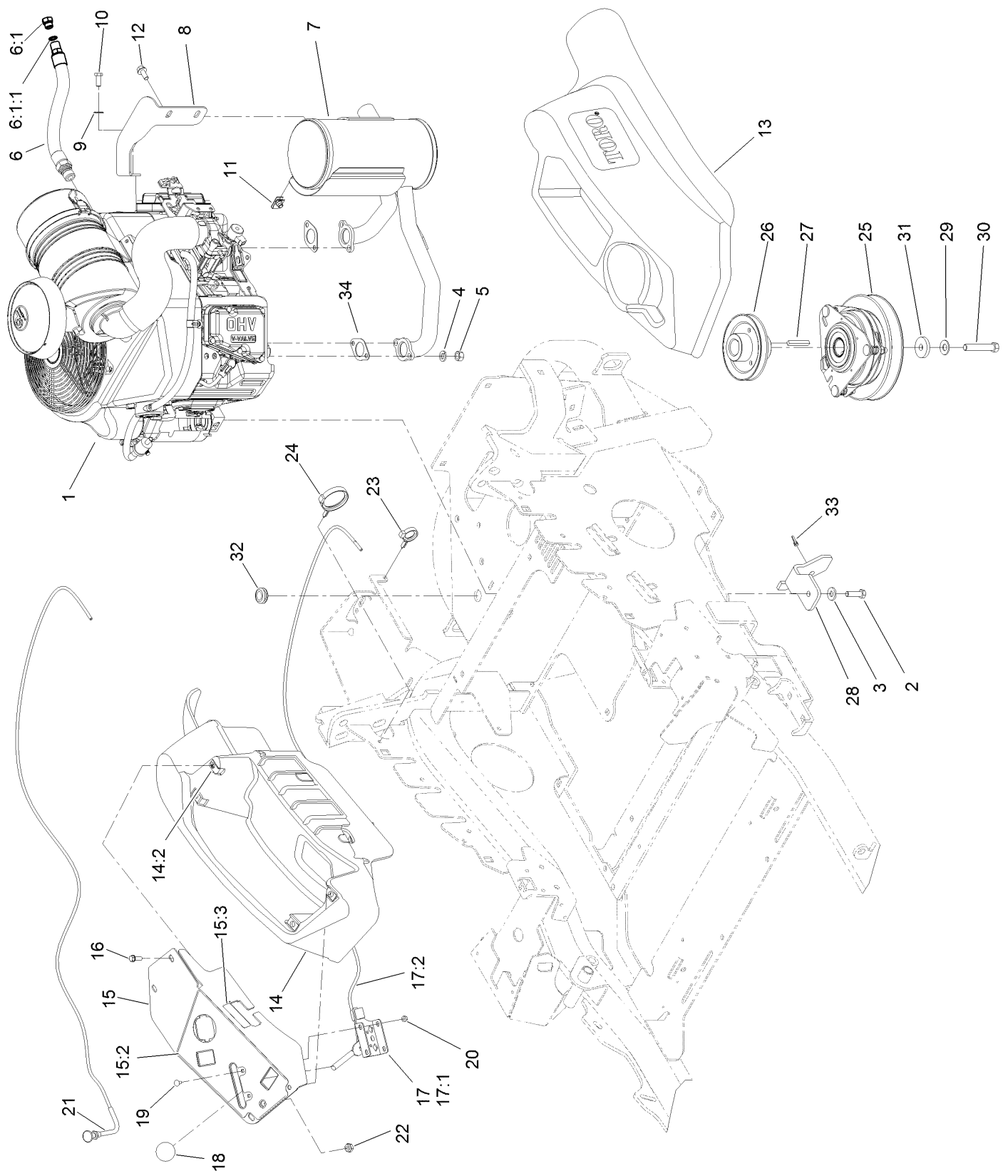

# Engine, Muffler and Control Panel Assembly (continued)

<i>Ref.</i>	<i>Part Number</i>	<i>Qty.</i>	<i>Description</i>	<i>Ref.</i>	<i>Part Number</i>	<i>Qty.</i>	<i>Description</i>
1		1	Engine-Kawasaki, Fx730 ●■	17	110-5727	1	Throttle Control ASM
2	323-7	4	Screw-HH	17:1	112-2334	1	Lever-Throttle
3	98-5975	4	Washer-Belleville	17:2	110-5728	1	Cable-Throttle
4	114-3550	4	Washer-Lock, Spring	18	1-603175	1	Knob-Ball
5	114-3549	4	Nut	19	1-807513	2	Bolt-CARR
6	116-4924	1	Engine Oil Drain Hose ASM	20	3296-2	2	Nut-Lock, NI
6:1	353-508	1	Plug-HH	21	115-2753	1	Control-Choke
6:1:1	237-42	1	O-Ring	22	3220-3	1	Nut-HJ
7	119-2645	1	Muffler	23	105-1853	1	Clamp-Hose
8	119-2659	1	Bracket-Muffler	24	117-7817	1	Clamp-Harness
9	1-303334	1	Washer-Spring	25	119-2595	1	Clutch
10	33114-020	1	Screw-HH	26	119-9915	1	Pulley-Engine
11	94-2413	2	U-Nut	27	608006	1	Key-Square
12	3234-5	2	Screw-HHF	28	119-2658-01	1	Bracket-Stop, Clutch
13	119-2602	1	LH Console ASM	29	1-603610	1	Washer-Spring
14	119-2603	1	RH Console ASM	30	3212-10	1	Screw-HH
14:2	107069	4	Clip	31	107-4136	1	Washer
15	119-2694	1	Control Panel ASM	32	112-7069	1	Grommet
15:2	119-2501	1	Decal-Panel, Control	33	1-303287	1	Tie-Cable
15:3	114-4466	1	Decal-Fuses	34	1-653313	2	Gasket-Exhaust
16	32105-15	4	Screw-HWH				

● Not serviced separately

■ Obtain parts from [www.kawpowerepc.com](http://www.kawpowerepc.com)

# Deck Lift Assembly

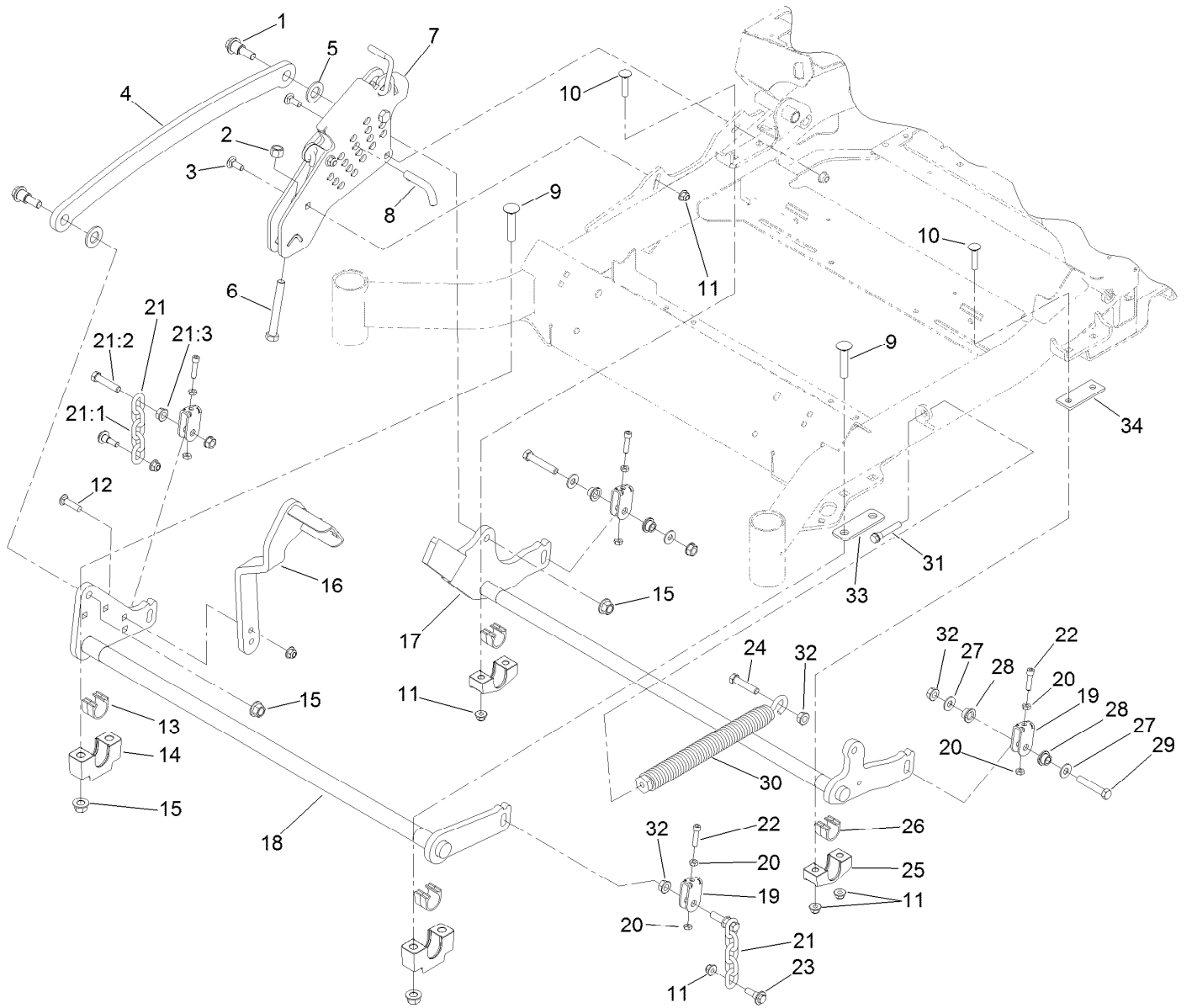

## Deck Lift Assembly (continued)

<i>Ref.</i>	<i>Part Number</i>	<i>Qty.</i>	<i>Description</i>	<i>Ref.</i>	<i>Part Number</i>	<i>Qty.</i>	<i>Description</i>
1	116-0780	2	Screw-HHF, Shoulder	20	3218-2	8	Nut-Jam
2	3296-23	1	Nut-Lock, NI	21	116-0756	2	Deck Lift Chain ASM
3	3231-2	2	Bolt-CARR	21:1	1-633447	1	Chain-Lift, Deck
4	116-0797-03	1	Link-Lift, Deck	21:2	109-9065	1	Screw-HH
5	3256-28	2	Washer-Flat	21:3	32128-37	1	Nut-HF
6	116-0559	1	Bolt-TAP	22	322-47	4	Screw-HH
7	120-2530	1	HOC ASM	23	109-9840	2	Screw-Shoulder, HHF
8	116-5584	1	Pin-HOC	24	109-9065	1	Screw-HH
9	116-1700	4	Bolt-CARR	25	116-0818-03	2	Support-Cross Shaft, Rear Bearing
10	3231-5	4	Screw-CARR	26	109-7173	2	Bearing-Cross Shaft, Rear
11	104-8301	10	Nut-Flange, NI	27	3256-4	4	Washer-Flat
12	3231-4	2	Screw-CARR	28	116-2428	4	Bushing-Flanged
13	109-9410	2	Bearing-Cross Shaft, Front	29	324-10	2	Screw-HH
14	109-9409	2	Support-Cross Shaft, Front Bearing	30	116-0886	1	Extension Spring ASM
15	99-5107	6	Nut-Lock	31	92-7674	1	Bolt-Shoulder
16	116-1919-01	1	Lever-Foot	32	32128-37	6	Nut-HF
17	116-0459-03	1	Lift-Deck, Rear	33	121-7593-01	2	Spacer-Decklift, Front
18	116-2217-03	1	Cross Shaft-Front	34	121-7594-01	2	Spacer-Decklift, Back
19	109-9066	4	Yoke-Adjust, Deck				

# Height-of-Cut Assembly No. 120-2530

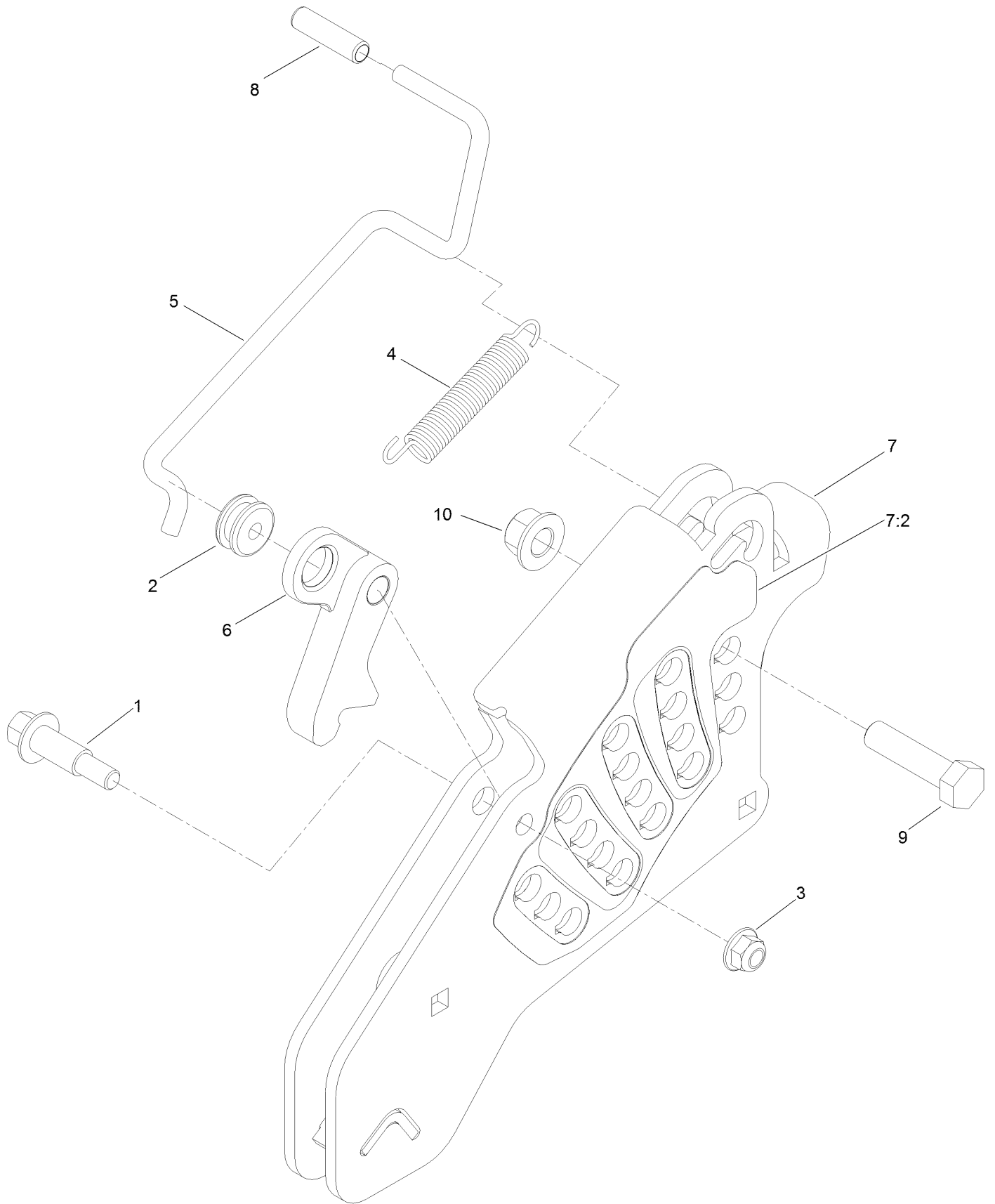

## Height-of-Cut Assembly No. 120-2530 (continued)

<i>Ref.</i>	<i>Part Number</i>	<i>Qty.</i>	<i>Description</i>	<i>Ref.</i>	<i>Part Number</i>	<i>Qty.</i>	<i>Description</i>
1	62-1330	1	Bolt-Shoulder	7	120-2531	1	HOC Plate ASM
2	109-7130	1	Grommet	7:2	120-2532	1	Decal-HOC
3	104-8301	1	Nut-Flange, NI	8	109-8250	1	Grip-Lever
4	109-7124	1	Spring-Extension	9	325-8	1	Screw-HH
5	109-7128	1	Rod-Lock, Transport	10	99-5107	1	Nut-Lock
6	116-0118	1	Pawl-Transport, HOC				

# Deck Assembly

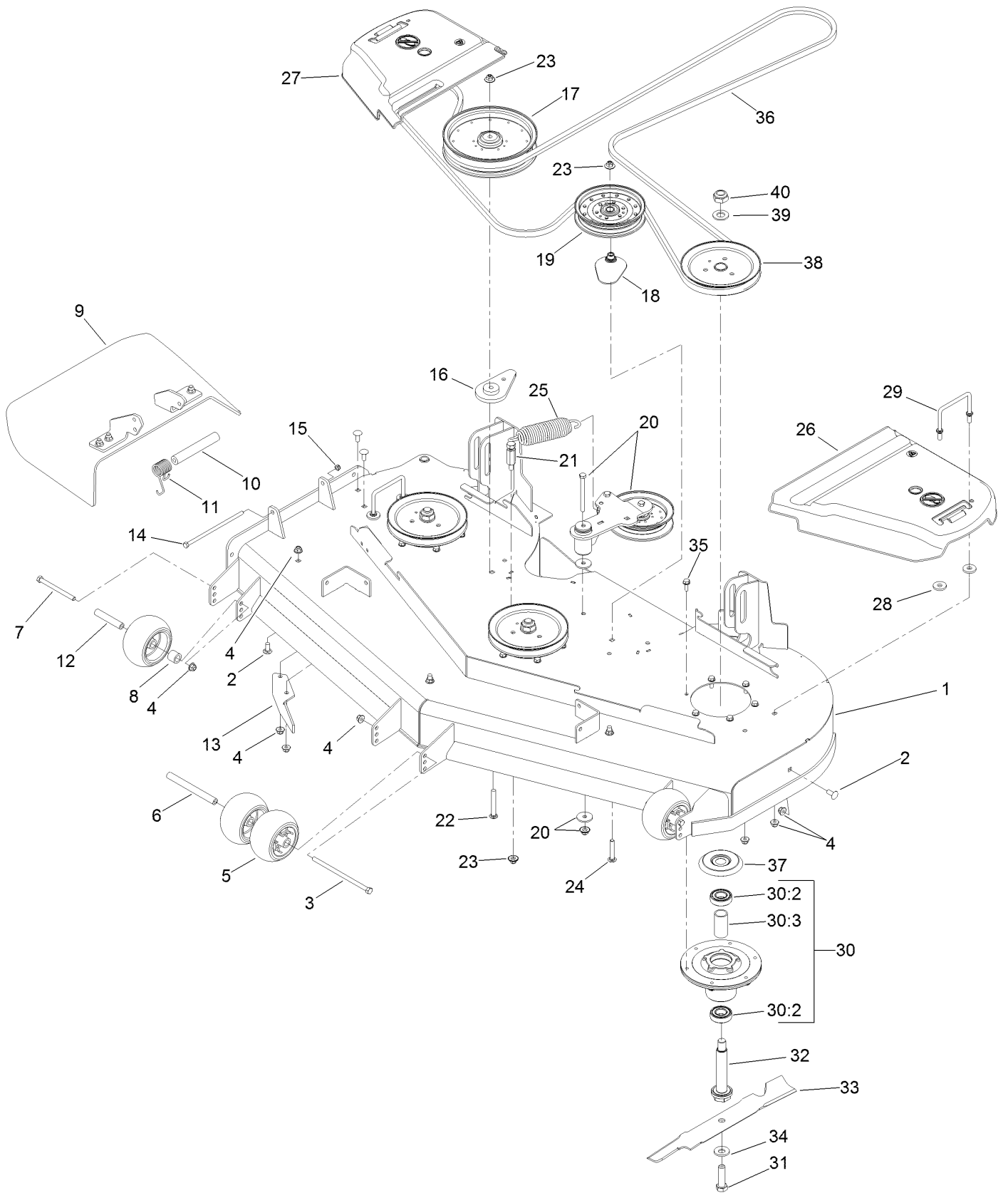

## Deck Assembly (continued)

<i>Ref.</i>	<i>Part Number</i>	<i>Qty.</i>	<i>Description</i>	<i>Ref.</i>	<i>Part Number</i>	<i>Qty.</i>	<i>Description</i>
1	120-2461	1	Deck Decal ASM	22	3231-42	1	Screw-CARR
2	3231-27	6	Screw-CARR	23	109-6658	3	Nut-Flange, NI
3	108-5388	1	Screw-HH	24	3231-40	1	Bolt-CARR, Short Neck
4	104-8301	13	Nut-Flange, NI	25	116-6317	1	Spring-Extension
5	1-603299	4	Roller-Scalp, Anti	26	109-6938	1	Cover-Belt, LH
6	98-5967	1	Spacer-Wheel	27	116-0094	1	Cover-Belt, RH
7	323-23	2	Screw-HH	28	1-373034	4	Washer
8	98-7913	2	Tube-Spacer	29	109-6982	2	Wireform-Cover
9	120-2451	1	Deflector ASM	30	120-5477	3	Spindle ASM
10	105-4622	1	Spacer	30:2	116-0720	2	Bearing-Ball
11	108-4052	1	Spring-Torsion	30:3	115-2641	1	Spacer-Bearing
12	98-7912	2	Tube-Spanner	31	51-4060	3	Screw-Blade
13	106-3216-01	1	Baffle-Discharge	32	120-2505	3	Spindle-Shaft
14	322-50	1	Screw-HH	33	115-9649-03	3	Blade-Hi Flo, 20.5In
15	3296-47	1	Nut-Lock, NI	34	125-1736	3	Washer-Belleville
16	109-9416	1	Spacer-Idler	35	32144-41	18	Screw-Taptite
17	109-8590	1	Pulley-Idler	36	114-5858	1	Belt-V
18	109-2872	1	Spacer-Pulley	37	117-7210	3	Shield-Bearing
19	116-4670	1	Pulley-Idler, Flat	38	120-7856	3	Pulley B Section
20		1	Idler Arm ASM ●	39	92-5836	3	Washer
21	114-5867	1	Anchor-Spring, Tall	40	3296-67	3	Nut-Lock, NI

● Not serviced separately

# Deck Decal Assembly No. 120-2461

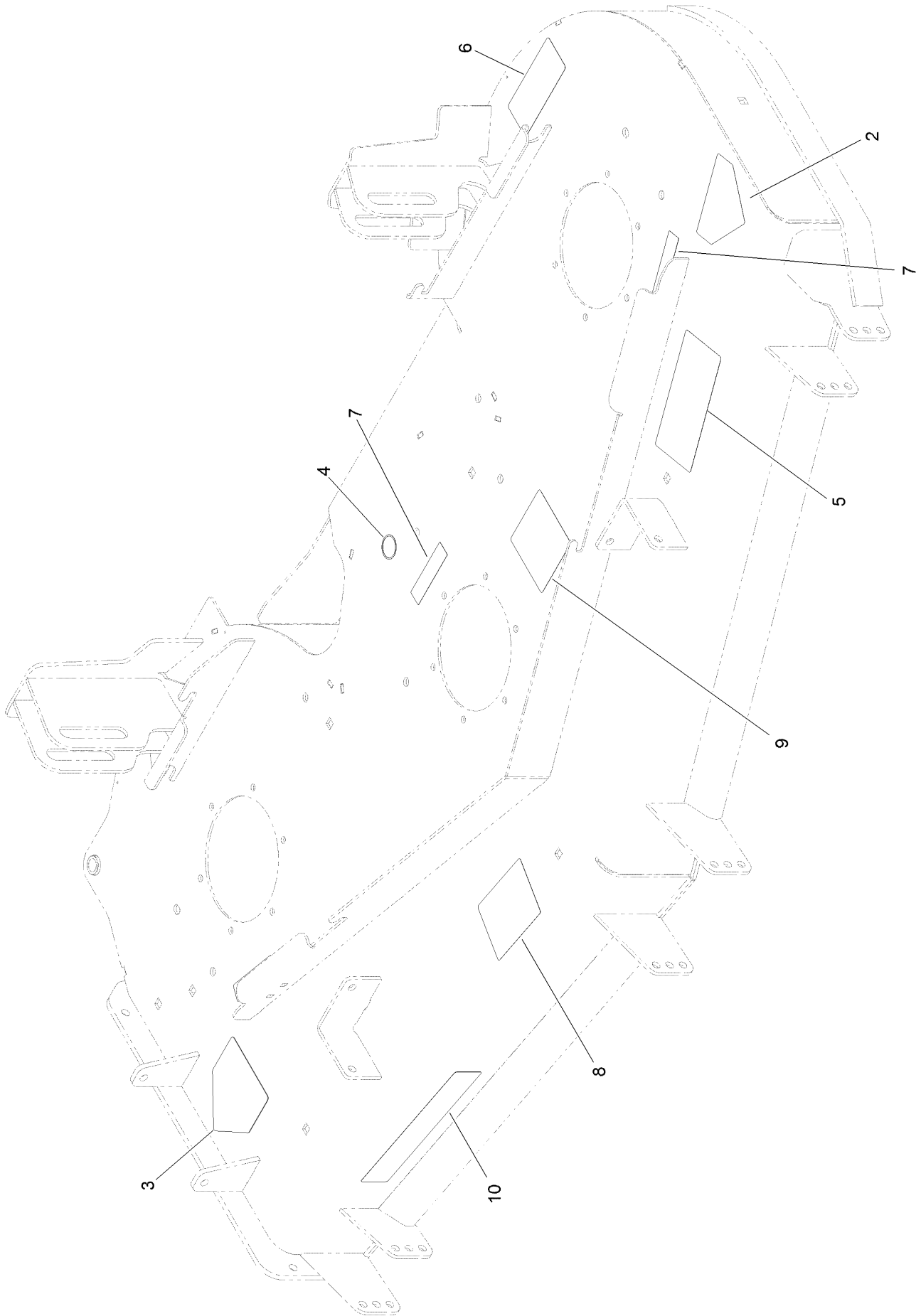

## Deck Decal Assembly No. 120-2461 (continued)

<i>Ref.</i>	<i>Part Number</i>	<i>Qty.</i>	<i>Description</i>	<i>Ref.</i>	<i>Part Number</i>	<i>Qty.</i>	<i>Description</i>
2	1-403005	1	Decal-Danger	6	68-8340	1	Decal-Torque
3	54-9220	1	Decal-Danger	7	98-5954	3	Decal-Missing Cover
4	58-6520	1	Decal-Grease	8	112-3858	1	Decal-Anti Scalp
5	66-1340	1	Decal-Danger, Thrown Object	9	117-8639	1	Decal-Routing, Deck Belt
				10	121-3206	1	Decal

# Deflector Assembly No. 120-2451

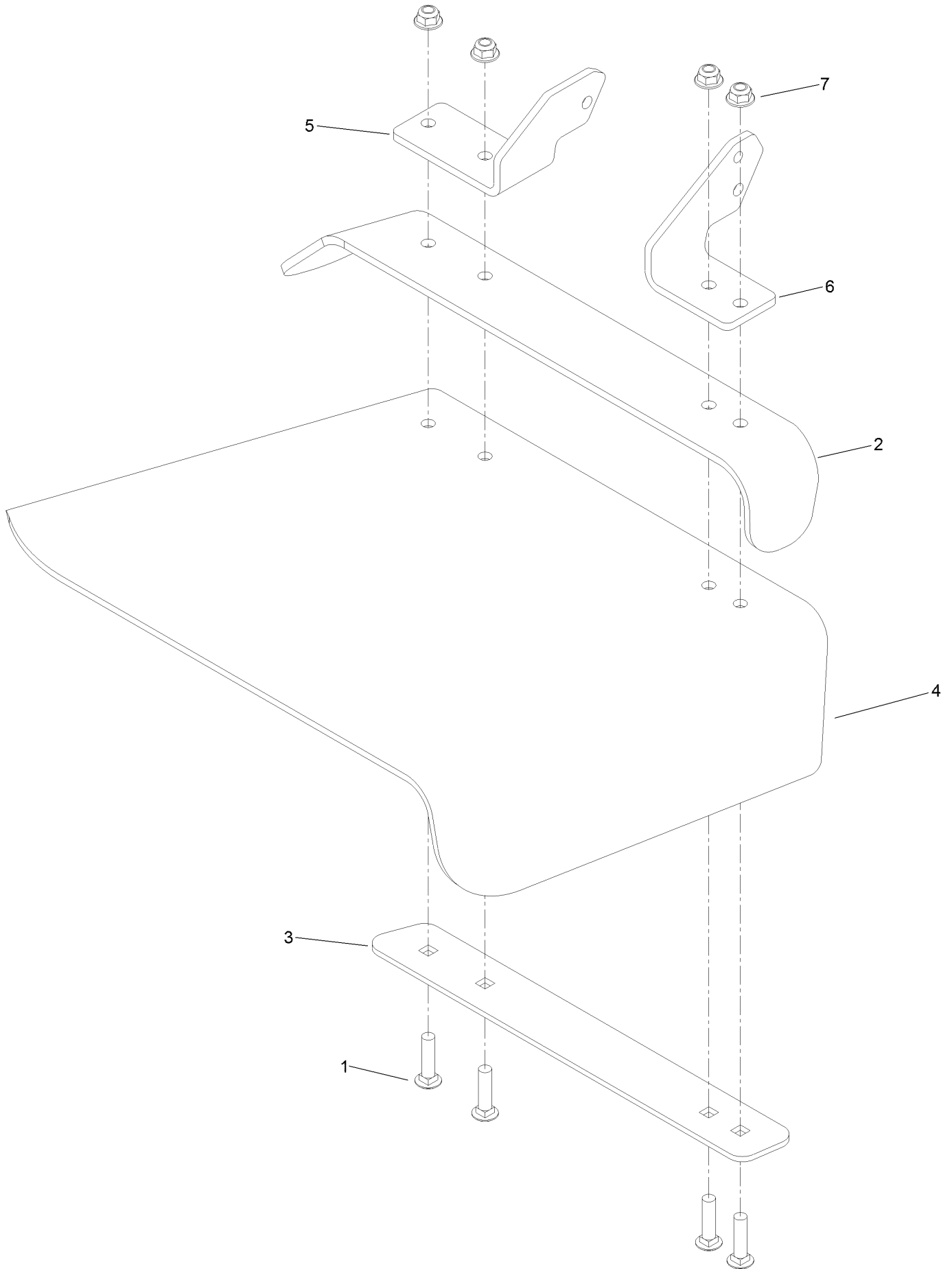

## Deflector Assembly No. 120-2451 (continued)

<i>Ref.</i>	<i>Part Number</i>	<i>Qty.</i>	<i>Description</i>	<i>Ref.</i>	<i>Part Number</i>	<i>Qty.</i>	<i>Description</i>
1	3231-4	4	Screw-CARR	5	108-4059-01	1	Plate-Hinge, Rear
2	106-3246-01	1	Deflector	6	106-3253-01	1	Plate-Hinge, Front
3	106-3248-03	1	Strap-Discharge	7	104-8301	4	Nut-Flange, NI
4	110-0759	1	Deflector-Rubber				

# Idler Assembly

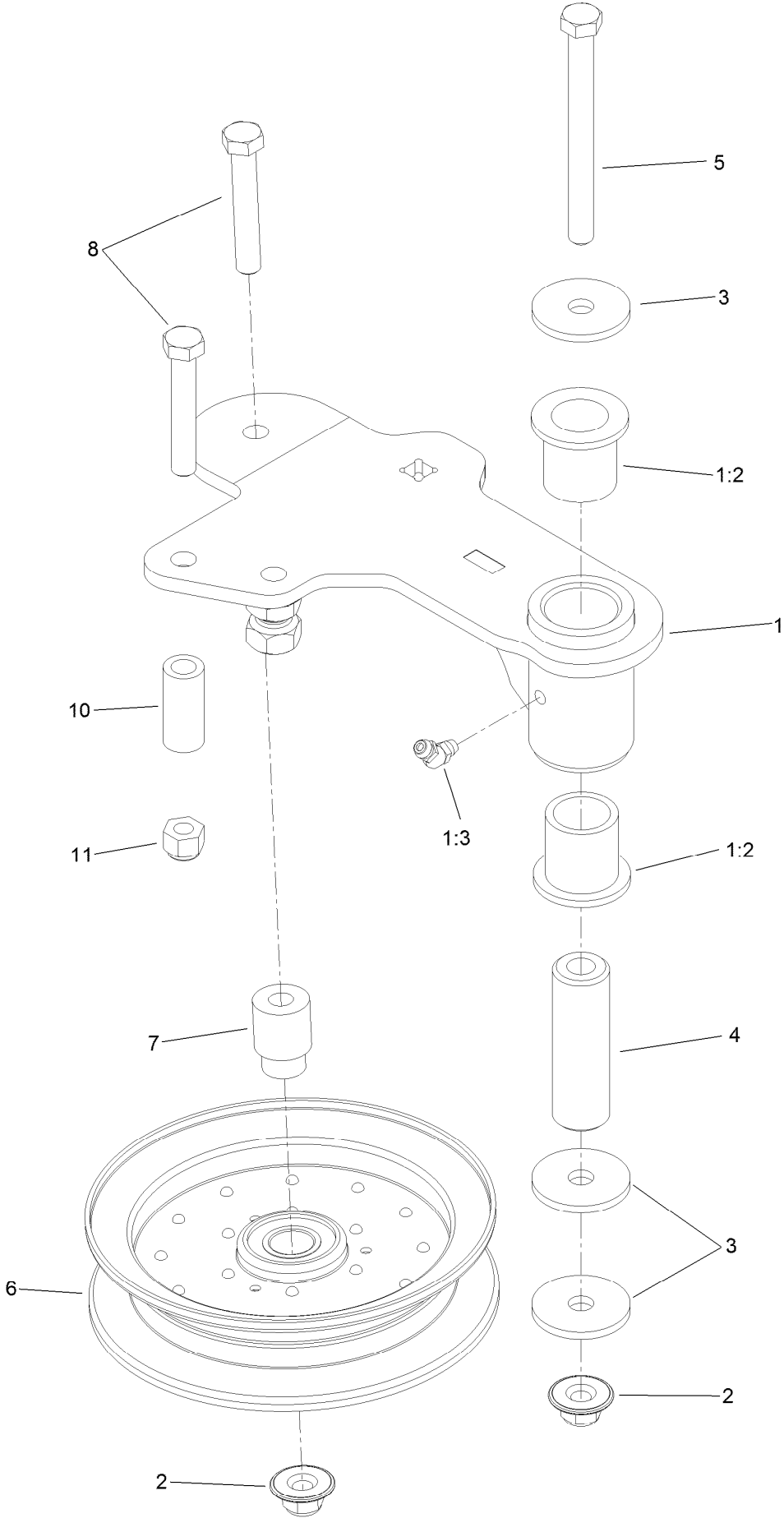

## Idler Assembly (continued)

<i>Ref.</i>	<i>Part Number</i>	<i>Qty.</i>	<i>Description</i>	<i>Ref.</i>	<i>Part Number</i>	<i>Qty.</i>	<i>Description</i>
1	120-2501	1	Idler Arm ASM	5	98-5961	1	Screw-HH
1:2	1-303514	2	Bearing-Flanged	6	116-4668	1	Idler-Pulley, Flanged
1:3	1481	1	Fitting-Grease	7	112-4212	1	Mount-Pulley
2	109-6658	2	Nut-Flange, NI	8	323-11	2	Screw-HH
3	1-213069	3	Washer	10	104-0151	1	Spacer
4	114-5848	1	Spacer-Plain	11	3296-39	1	Nut-Lock, NI

# Electrical Assembly

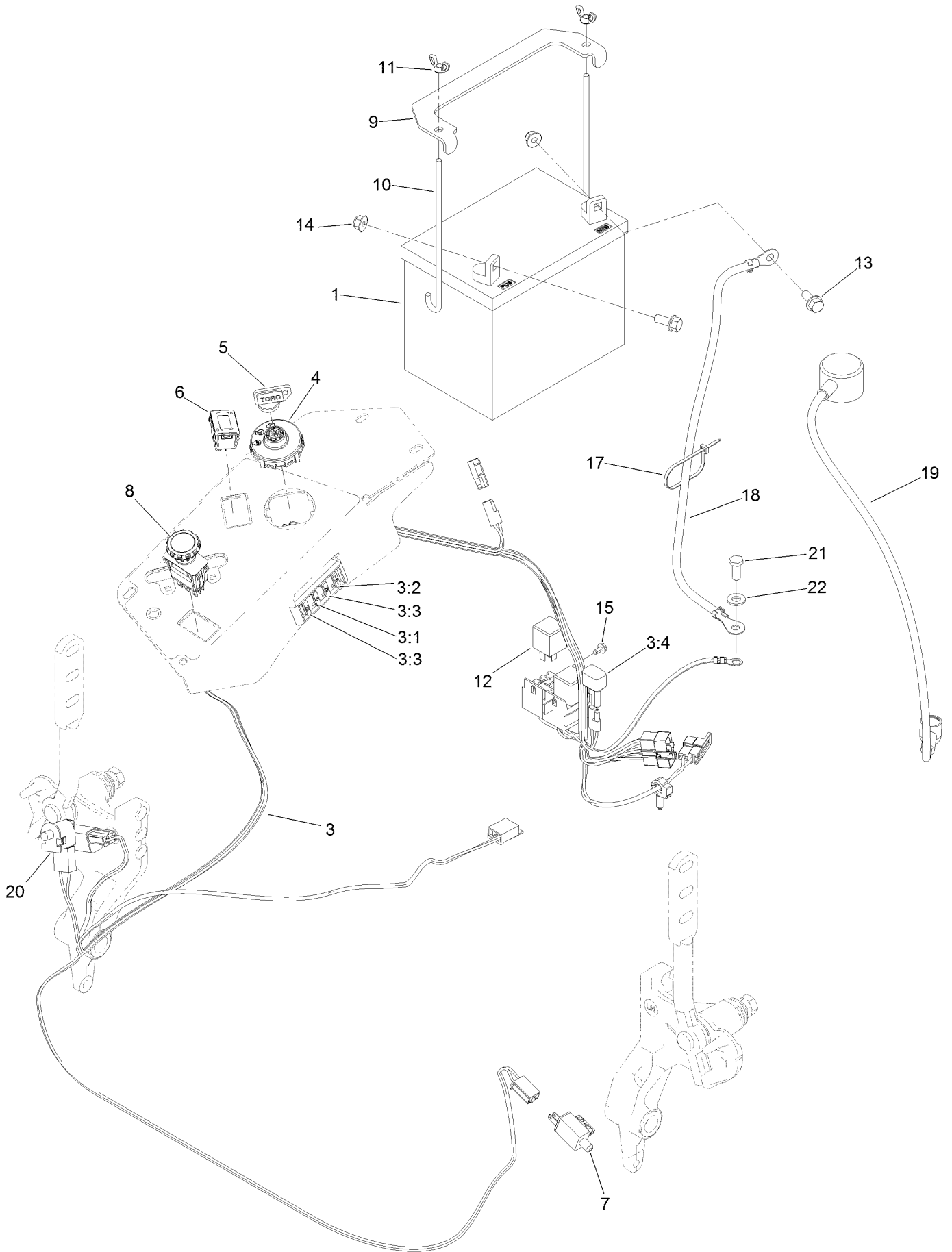

## Electrical Assembly (continued)

<i>Ref.</i>	<i>Part Number</i>	<i>Qty.</i>	<i>Description</i>	<i>Ref.</i>	<i>Part Number</i>	<i>Qty.</i>	<i>Description</i>
1	104-8162	1	Battery-Dry	10	1-633651	2	Bolt-Holddown
3	117-2582	1	Harness-Wire	11	1-543792	2	Wingnut
3:1	218-578	1	Fuse-Blade, 10 Amp	12	1-643275	2	Relay
3:2	109355	1	Fuse-Blade, 15 Amp	13	3234-5	2	Screw-HHF
3:3	109102	2	Fuse-Blade, 25 Amp	14	104-8300	2	Nut-Flange, NI
3:4	116-0053	1	Cap-Plug	15	104-2065	1	Screw-HWH
4	117-2221	1	Switch-Ignition	17	1-303287	3	Tie-Cable
5	63-8360	1	Key-Ignition	18	114-1218	1	Cable-Battery, Negative
6	120-2244	1	Hourmeter	19	115-3864	1	Cable-Battery, Positive
7	110-6765	2	Switch-Single Pole No	20	82-2190	1	Switch-Bail
8	116-0124	1	Switch-PTO, 10A	21	33114-020	1	Screw-HH
9	116-0042-03	1	Strap-Tie Down, Battery	22	33094-00	1	Washer-Plain

# Attachments and Accessories

## For 74145 Z Master Commercial 2000 Series Riding Mower with 60in TURBO FORCE Side Discharge Mower

<b>Product Name</b>	<b>Model/Part</b>
Turbo Baffle Kit .....	107-1634
Hypr-Oil 500 (quart) .....	114-4713
Hypr-Oil 500 (gallon).....	114-4714
Hypr-Oil 500-5 (5 gallon).....	114-4715
Bimini Folding Shade Assembly .....	115-4510
Blade-mulch, 20.50in .....	115-5002-03
Blade-hi Flo, 20.5in .....	115-9649-03
Light Kit.....	116-1154
Operator-Controlled Discharge Chute Kit .....	117-3600
Recycler Kit .....	120-2403
Z Stand Kit.....	121-4811
Deluxe Seat Kit .....	121-7595
MVP Belt and Blade Kit.....	127-1633
Toro Deluxe Rider Cover.....	490-7319
Spark Arrestor Screen .....	75-6880
E-Z VAC Twin Soft Bagger.....	78569
Blower and Drive Kit .....	78573
Filter Minder Gauge .....	99-4664
Trash Holder Kit.....	TC26

**Notes:**

**Notes:**

**Notes:**



**Count on it.**