



Count on it.

Parts Catalog

**Z Master[®] Commercial 3000
Series Riding Mower**

**with 48in TURBO FORCE[®] Side Discharge
Mower**

Model No. 74952—Serial No. 314000001 and Up



Ordering Replacement Parts

To order replacement parts, please supply the part number, the quantity, and the description of each part desired.

Understanding Reference Numbers

Each identified part in an illustration has a reference number. The reference number for a part also appears in the parts list, along with other information about the part.

This catalog uses two special reference number formats, one to indicate parts in a service assembly and another to indicate the quantity of a given part in an illustration.

Service Assembly Reference Numbers

Parts in service assemblies have reference numbers in the form a:b. The a represents the reference number of the entire service assembly and the b represents a sequential number unique to each part within the service assembly.

For example, a wheel assembly might be identified by reference number 6, the tire by 6:1, the valve by 6:2, and the wheel by 6:3. When you order the assembly identified by reference number 6, you receive all parts identified by reference numbers 6:1, 6:2, and 6:3. However, you may also order any part individually. Reference numbers of this type appear in illustration and in parts lists.

Reference Numbers Indicating Quantity

In an illustration, if a reference number indicates more than one part, the reference number has the form nX y. The n represents the quantity of the part, the X is the multiplication symbol, and the y represents the reference number.

For example, in an illustration, the reference number 2X 37 means that two of the parts identified by reference number 37 are indicated.

List of Abbreviations

AR: as required

ASM: assembly

BBC: blade brake control

BHTF: button head thread forming

CARR: carriage

CCW: counter clockwise

CW: clockwise

DEG: degrees

DPA: Dual Point Adjustment

ECM: electronic control module

EXT: external

FH: flat head

GA: gauge

HD: heavy-duty

HF: hex flange

HH: hex head

HHF: hex head flange

HHFTF: hex head flange thread forming

HJ: hex jam

HLH: hex lag head

HOC: height-of-cut

HSBH: hex socket button head

HSFH: hex socket flat head

HSH: hex socket head

HWH: hex washer head

HWHTF: hex washer head thread forming

HYD: hydraulic

LH: left hand

LP: Liquefied Petroleum Gas

LPG: Liquefied Petroleum Gas

NI: nylon insert

NPTF: national pipe thread fine

PFH: phillips flat head

PPH: phillips pan head

PPHTF: phillips pan head thread forming

PRH: phillips round head

PTH: phillips truss head

PTO: power-take-off

RH: right hand

ROPS: roll-over protection system

RRB: rear roller brush

SFH: slotted fillister head

SHH: slotted hex head

SHWH: slotted hex washer head

SPH: slotted pan head

SQH: square head

SRH: slotted round head

STD: standard

TAP: self tapping

TTH: torx truss head

Contents

Frame and Caster Wheel Assembly	4
Roll-Over Protection System Assembly No. 116-0231	6
Caster Wheel and Fork Assembly	8
Hydraulic Pump, Idler and Belt Assembly	10
Pump Idler Assembly No. 116-1255	12
LH Hydro Assembly No. 116-6417	14
RH Hydro Assembly No. 116-6418	16
Rear Wheel and Park Brake Assembly	18
Parking Brake Handle Assembly No. 116-7551	20
Fuel Tank Mounting Assembly	22
Fuel Tank Assembly No. 116-3978	24
Seat Mount Assembly	26
Seat Assembly No. 116-0038	28
Motion Control Assembly	30
Fender, Console and Control Assembly	32
Electrical Assembly	34
Deck Lift Assembly	36
Height-of-Cut Assembly No. 109-7438	38
Engine, Clutch and Muffler Assembly	40
Deck Assembly	42
Deck Decal Assembly No. 114-5805	44
Idler Assembly	46
Spindle Assembly No. 119-8560	48
Rubber Deflector Assembly No. 108-2792	50
Attachments and Accessories	52

Frame and Caster Wheel Assembly

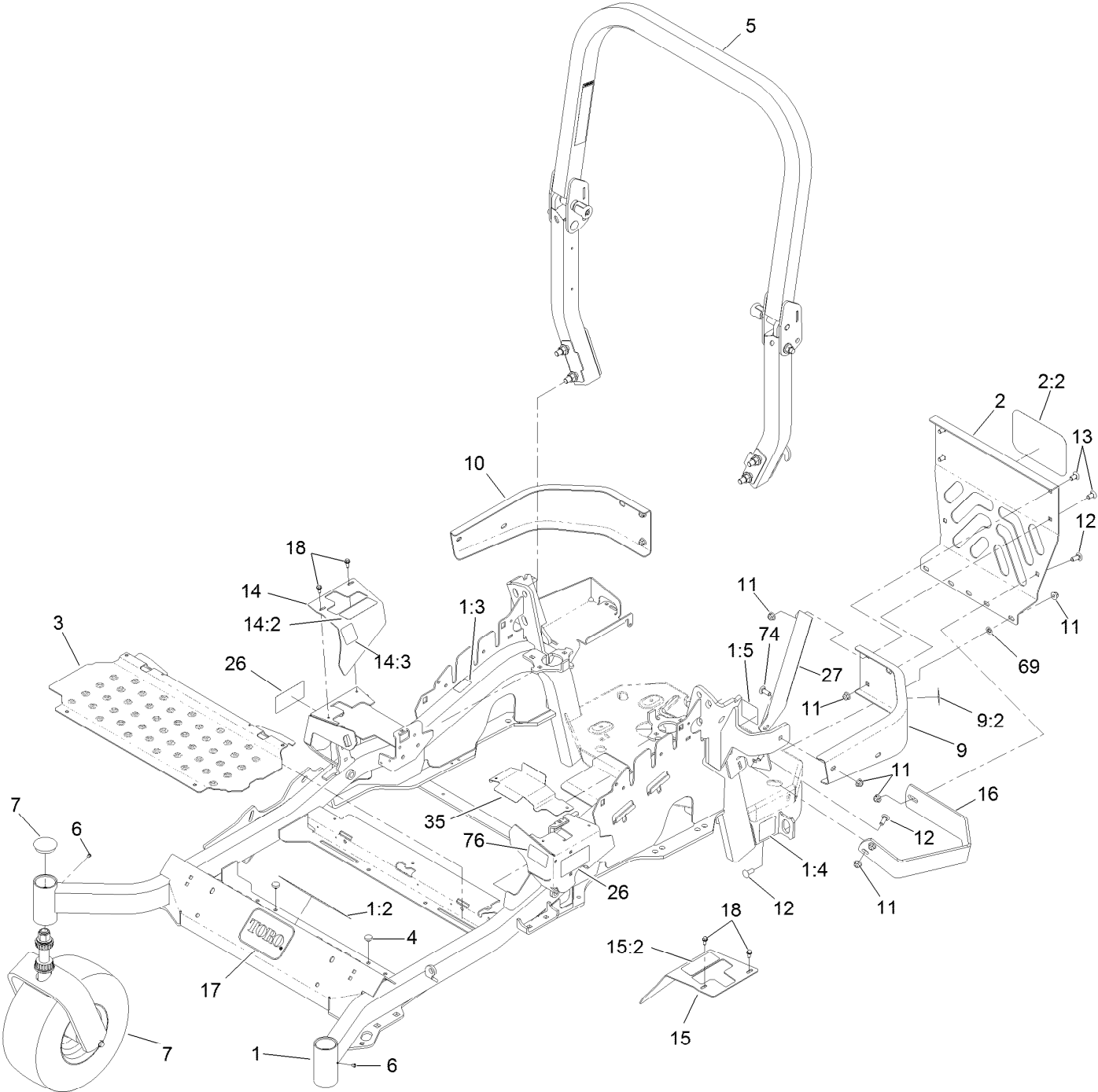

Frame and Caster Wheel Assembly (continued)

<i>Ref.</i>	<i>Part Number</i>	<i>Qty.</i>	<i>Description</i>	<i>Ref.</i>	<i>Part Number</i>	<i>Qty.</i>	<i>Description</i>
1	116-5900	1	Mainframe ASM	13	3231-21	3	Screw-CARR
1:2	116-3303	1	Decal-Slope	14	116-5899	1	RH Motion Control Cover ASM
1:3	103-2076	2	Decal-Caution	14:2	109-7232	1	Decal-Motion Control
1:4	116-0205	2	Decal-Belt Drive	14:3	116-5944	1	Decal-Park Brake
1:5	116-4858	1	Decal-Spark Arrester	15	116-0580	1	LH Motion Control Cover ASM
2	115-7410	1	Rear Guard ASM	15:2	109-7232	1	Decal-Motion Control
2:2	67-7320	1	Decal	16	126-2067-03	1	Guard-Muffler
3	116-8898-01	1	Floorpan	17	68-3640	1	Decal
4	1-513658	2	Bumper	18	32144-10	4	Screw-HWH
5	116-0231	1	ROPS ASM	26	120-5892	2	Decal
6	1-811010	2	Plug	27	117-0903-03	1	Strap
7		2	Caster Wheel ASM ●	35	116-2999-01	1	Guard-Belt
9	116-0180	1	LH Bumper ASM	69	107-3154	2	Nut-Push
9:2	103-2076	1	Decal-Caution	74	3231-25	1	Bolt-CARR
10	116-0057-03	1	Bumper-RH	76	116-1654	1	Decal-Fuel Fill
11	104-8301	11	Nut-Flange, NI				
12	3231-22	7	Screw-CARR				

● Not serviced separately

Roll-Over Protection System Assembly No. 116-0231

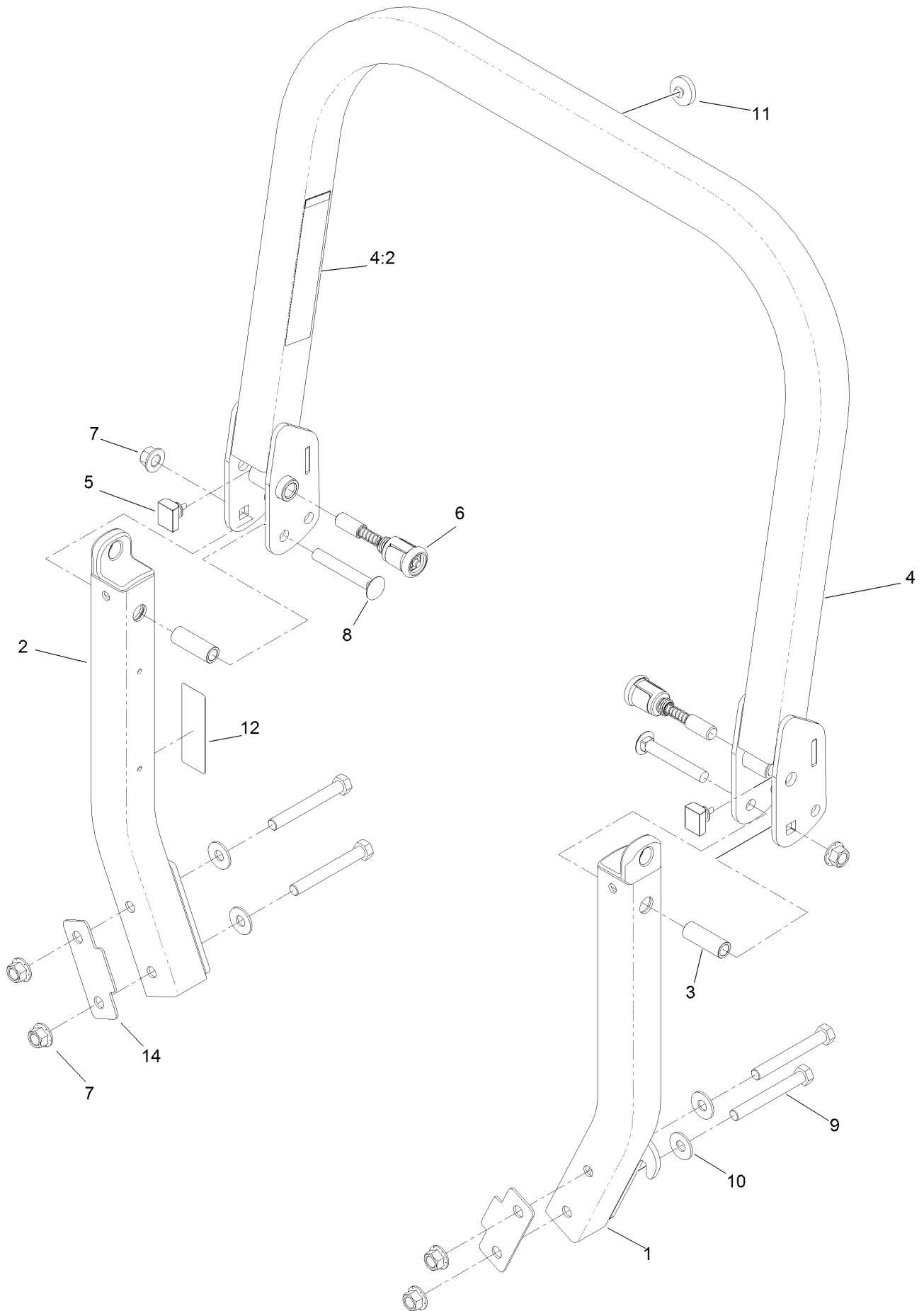

Roll-Over Protection System Assembly No. 116-0231 (continued)

<i>Ref.</i>	<i>Part Number</i>	<i>Qty.</i>	<i>Description</i>	<i>Ref.</i>	<i>Part Number</i>	<i>Qty.</i>	<i>Description</i>
1		1	Leg-ROPS, LH ●	7	99-5107	6	Nut-Lock
2		1	Leg-ROPS, RH ●	8	3233-10	2	Screw-CARR
3	109-6653	2	Spacer	9	325-17	4	Screw-HH
4		1	Upper ROPS ASM ●	10	109-9505	4	Washer-Spring
4:2	107-2102	1	Decal-Warning, Folding ROPS	11	109-9233	1	Bumper-Push-In, Rubber
5	109-5337	2	Bumper-ROPS	12	116-0090	1	Decal-Caution
6	116-0104	2	Pin-Spring	14	116-0960	2	Spacer

● Not serviced separately

Caster Wheel and Fork Assembly

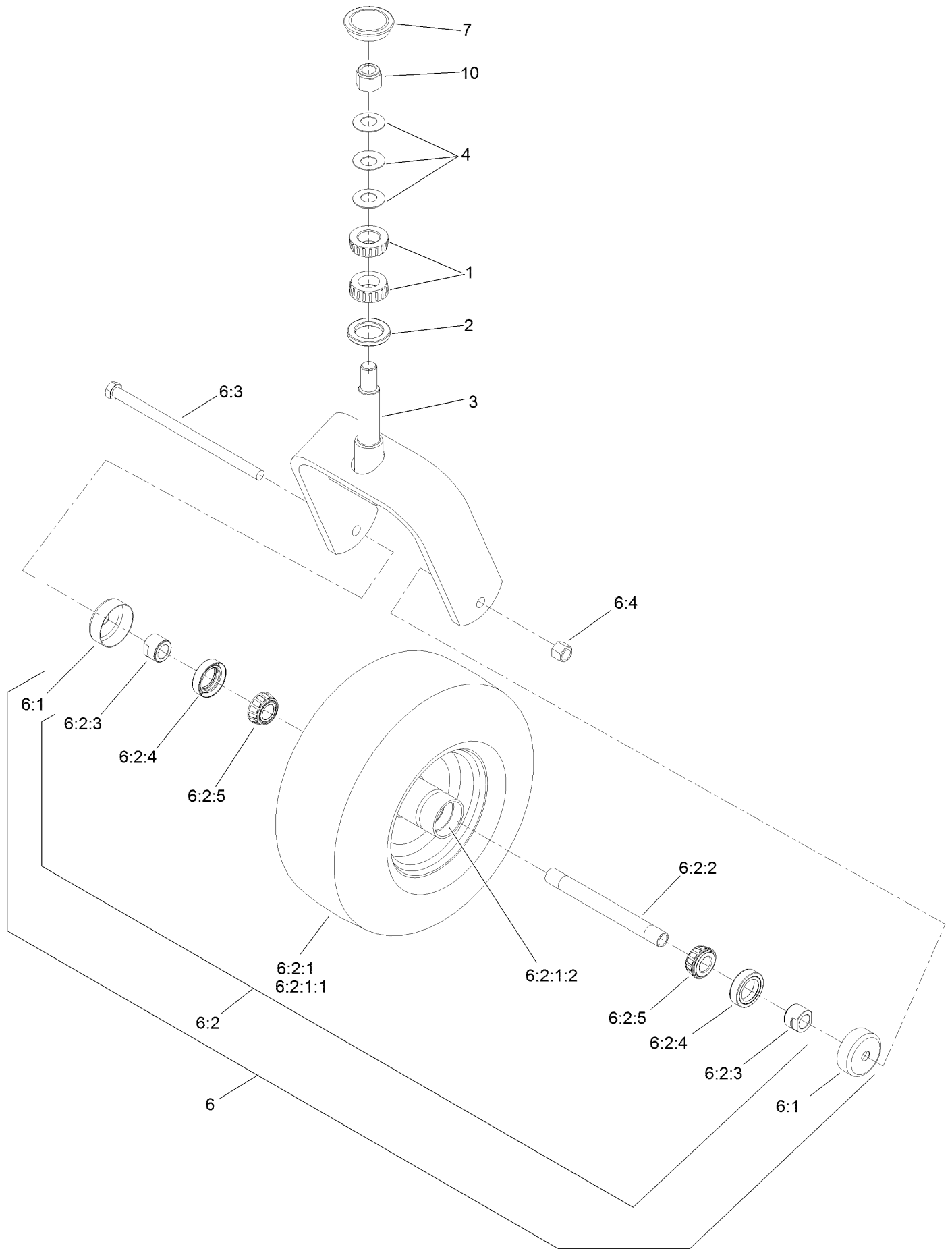

Caster Wheel and Fork Assembly (continued)

<i>Ref.</i>	<i>Part Number</i>	<i>Qty.</i>	<i>Description</i>	<i>Ref.</i>	<i>Part Number</i>	<i>Qty.</i>	<i>Description</i>
1	1-543509	2	Bearing-Roller, Tapered	6:2:1:2	1-633584	2	Bearing-Cup
2	116-5647	1	Seal-Grease	6:2:2	103-3155	1	Axle-Caster
3	116-6702-01	1	Fork-Caster	6:2:3	103-3051	2	Spacer-Nut
4	1-633508	3	Washer-Bellville	6:2:4	103-0063	2	Seal-Caster
6	127-9535	1	Wheel And Axle ASM	6:2:5	1-633585	2	Bearing-Cone, Taper
6:1	103-2768	2	Guard-Seal	6:3	325-36	1	Screw-HH
6:2		1	Wheel And Bearing ASM ●	6:4	3296-23	1	Nut-Lock, NI
6:2:1		1	Wheel And Tire ASM ●	7	103-4882	1	Cap-Grease
6:2:1:1	1-633002	1	Tire	10	3296-51	1	Nut-Lock, NI

● Not serviced separately

Hydraulic Pump, Idler and Belt Assembly

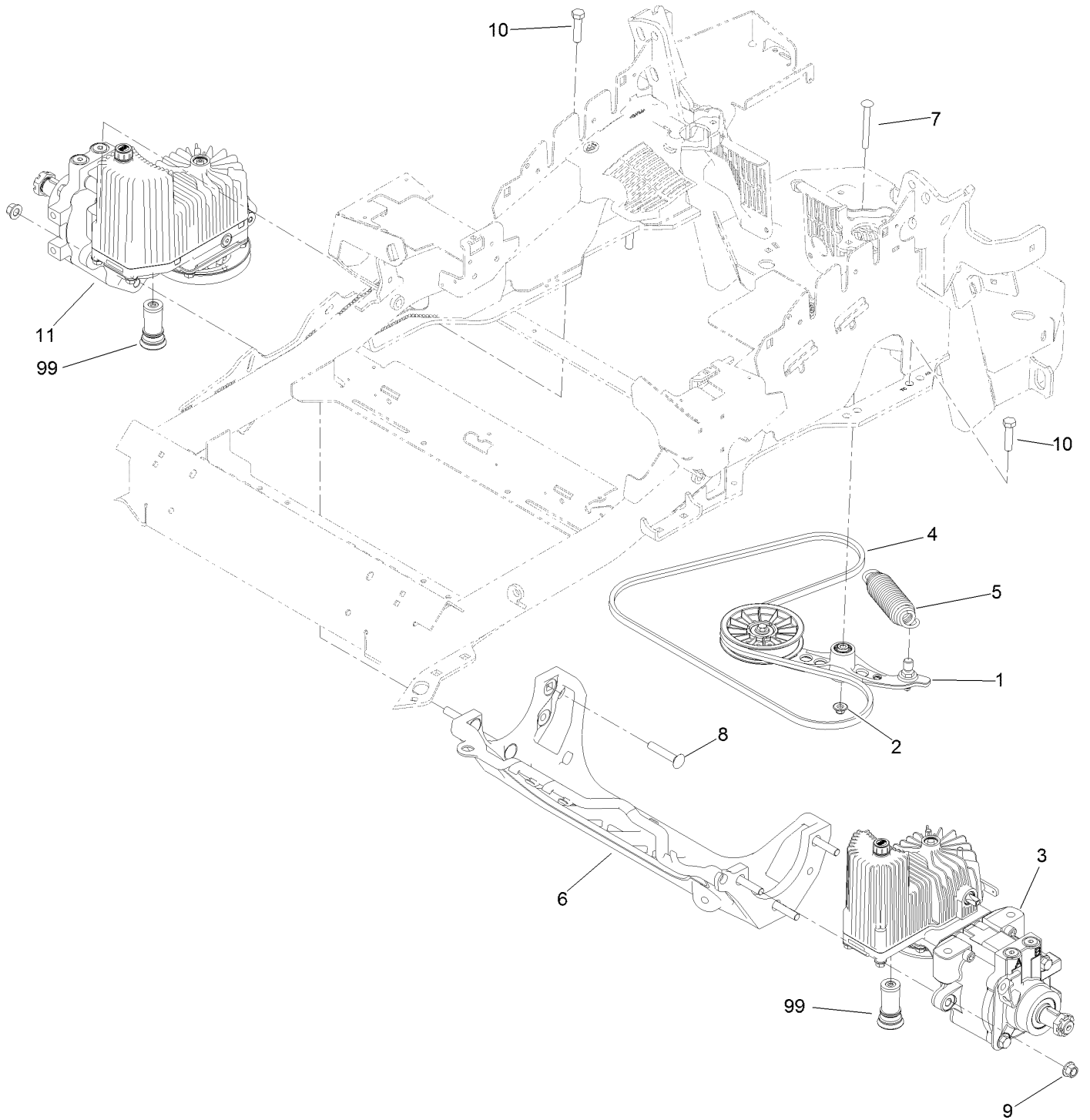

Hydraulic Pump, Idler and Belt Assembly (continued)

<i>Ref.</i>	<i>Part Number</i>	<i>Qty.</i>	<i>Description</i>	<i>Ref.</i>	<i>Part Number</i>	<i>Qty.</i>	<i>Description</i>
1	116-1255	1	Pump Idler ASM	9	99-5107	6	Nut-Lock
2	109-6658	1	Nut-Flange, NI	10	325-8	4	Screw-HH
3	116-6417	1	LH Hydro ASM (12Cc No Fan)	11	116-6418	1	RH Hydro ASM (12Cc No Fan)
4	116-1953	1	Belt-V	99	114-4713	1	Hypr-Oil 500 (Quart) ●
5	116-6317	1	Spring-Extension	99	114-4714	1	Hypr-Oil 500 (Gallon) ●
6	109-9375	1	Cradle-Hydro	99	114-4715	1	Hypr-Oil 500-5 (5 Gallon) ●
7	116-1502	1	Bolt-Shoulder, Carriage	99	117-0390	1	Filter-Hydro
8	126-0095	6	Screw-CARR				

● Not illustrated

Pump Idler Assembly No. 116-1255



Pump Idler Assembly No. 116-1255 (continued)

<i>Ref.</i>	<i>Part Number</i>	<i>Qty.</i>	<i>Description</i>	<i>Ref.</i>	<i>Part Number</i>	<i>Qty.</i>	<i>Description</i>
2	43-0940	1	Spacer	8	323-8	1	Screw-HH
3	103-3504	2	Bearing-Spherical	9	32120-10	2	Ring-Snap
4	103-3505	1	Seal-Double Lip	10	302-19	1	Fitting-Grease
5	103-3506	1	Seal-Single Lip	11	109-8076	1	Pulley-Idler
6	109-6658	1	Nut-Flange, NI	12	116-3467	1	Pin-Spring, Anchor
7	106-7159	2	O-Ring				

LH Hydro Assembly No. 116-6417

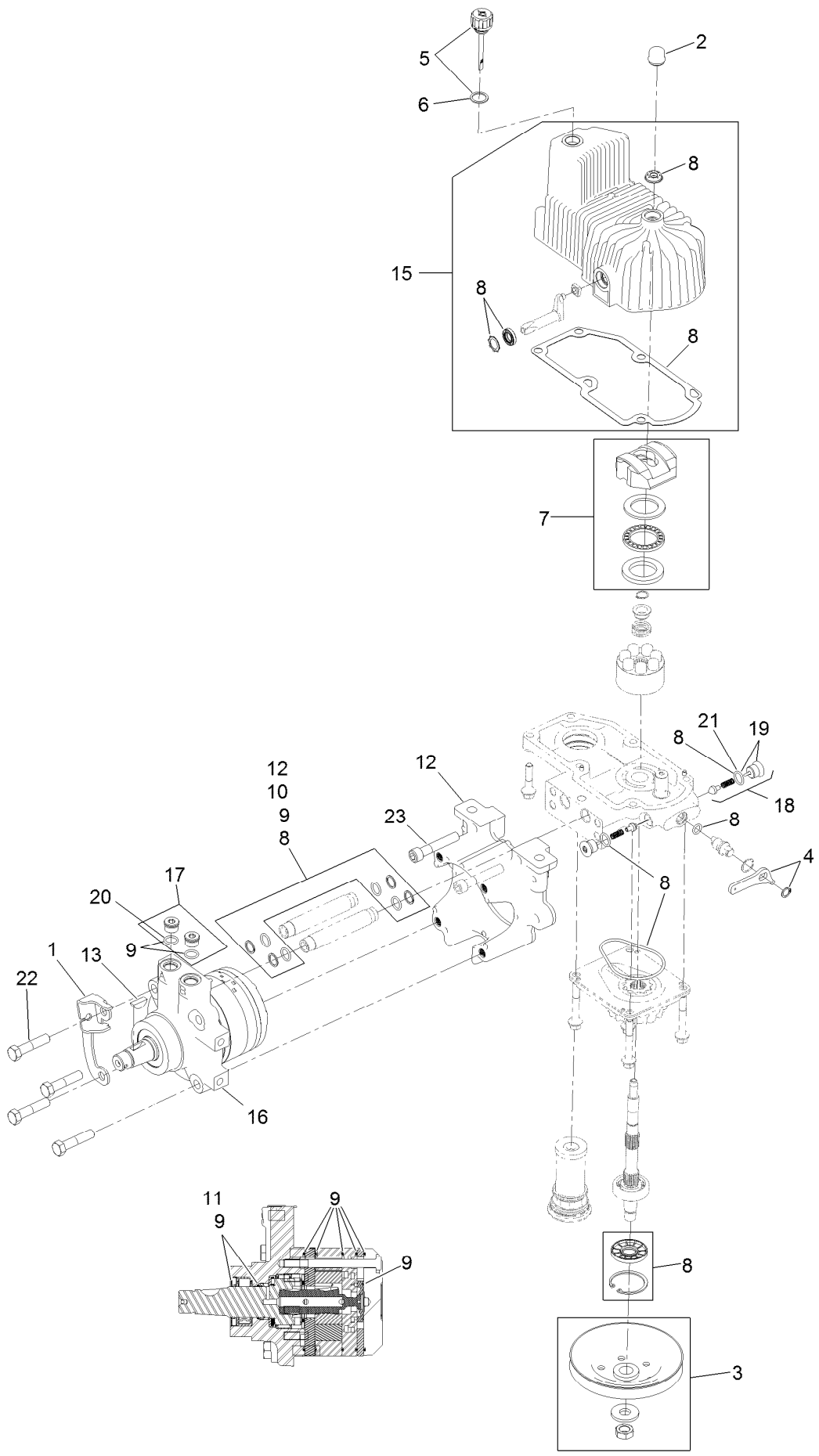

LH Hydro Assembly No. 116-6417 (continued)

<i>Ref.</i>	<i>Part Number</i>	<i>Qty.</i>	<i>Description</i>	<i>Ref.</i>	<i>Part Number</i>	<i>Qty.</i>	<i>Description</i>
1	116-6859	1	Bracket-Anchor, Cable	12	116-5469	1	Nose Cup-Uht
2	116-3052	1	Cover-Shaft, Hydro	13	3257-42	1	Key-Woodruff
3	116-0234	1	Pulley Kit	15	116-3287	1	Housing-LH
4	116-0235	1	Handle-Bypass Valve, Hydro	16	116-8915	1	Motor-Hydraulic LH 240Cc
5	116-0236	1	Dipstick-Hydro W/Gasket	17	116-7901	1	Magnetic Plugs Service Kit
6	116-0237	1	Gasket-Dipstick, Hydro	18	116-1630	2	Check Valve ASM
7	116-1367	1	Swash Block Kit	19	116-1631	2	Plug-Check (W/O-Ring)
8	116-1368	1	Pump Seal Kit	20	76-1900	2	O-Ring
9	116-1369	1	Motor Seal Kit	21	116-8662	2	O-Ring-Check Valve
10	116-1370	1	Tube Seal Kit	22	116-8974	4	Screw HH
11	116-1371	1	Output Shaft Seal Kit	23	116-8975	2	Screw-HSH
				99	116-1373	1	Flow Test Kit ●

● Not illustrated

RH Hydro Assembly No. 116-6418

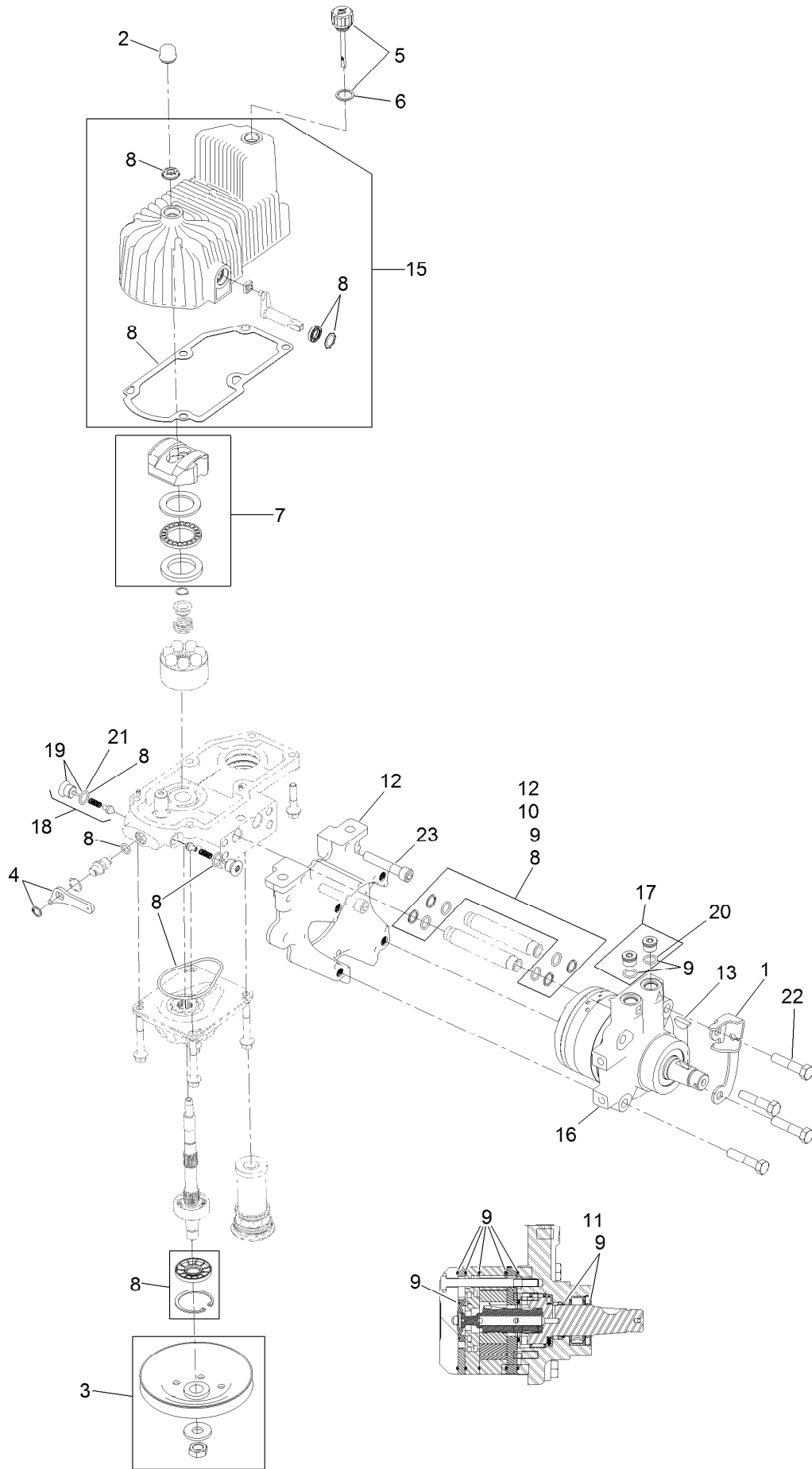

RH Hydro Assembly No. 116-6418 (continued)

<i>Ref.</i>	<i>Part Number</i>	<i>Qty.</i>	<i>Description</i>	<i>Ref.</i>	<i>Part Number</i>	<i>Qty.</i>	<i>Description</i>
1	116-6859	1	Bracket-Anchor, Cable	12	116-5469	1	Nose Cup-Uht
2	116-3052	1	Cover-Shaft, Hydro	13	3257-42	1	Key-Woodruff
3	116-0234	1	Pulley Kit	15	116-3288	1	Housing-RH
4	116-0235	1	Handle-Bypass Valve, Hydro	16	116-8916	1	Motor-Hydraulic RH 240Cc
5	116-0236	1	Dipstick-Hydro W/Gasket	17	116-7901	1	Magnetic Plugs Service Kit
6	116-0237	1	Gasket-Dipstick, Hydro	18	116-1630	2	Check Valve ASM
7	116-1367	1	Swash Block Kit	19	116-1631	2	Plug-Check (W/O-Ring)
8	116-1368	1	Pump Seal Kit	20	76-1900	2	O-Ring
9	116-1369	1	Motor Seal Kit	21	116-8662	2	O-Ring-Check Valve
10	116-1370	1	Tube Seal Kit	22	116-8974	4	Screw HH
11	116-1371	1	Output Shaft Seal Kit	23	116-8975	2	Screw-HSH
				99	116-1373	1	Flow Test Kit ●

● Not illustrated

Rear Wheel and Park Brake Assembly

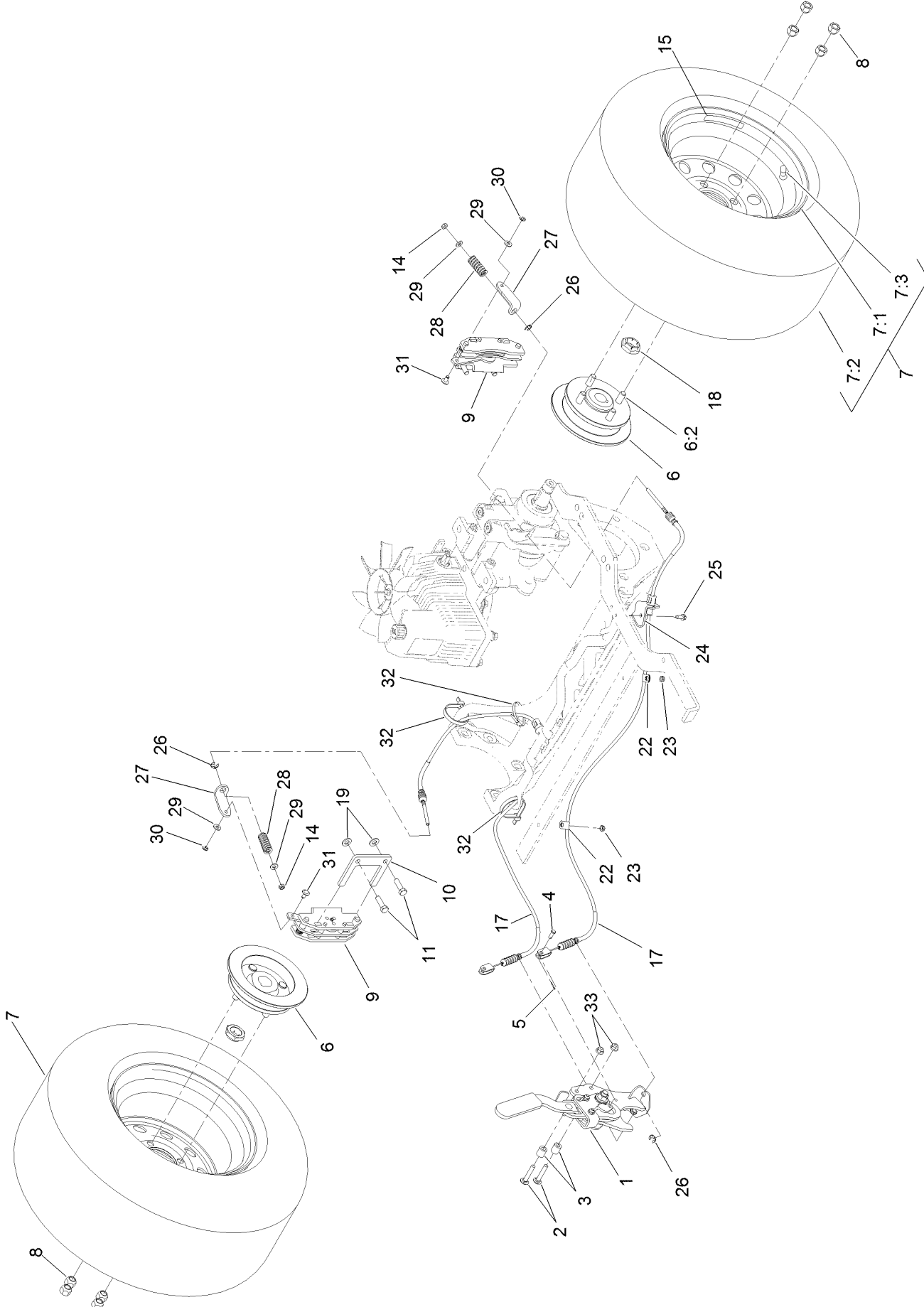

Rear Wheel and Park Brake Assembly (continued)

<i>Ref.</i>	<i>Part Number</i>	<i>Qty.</i>	<i>Description</i>	<i>Ref.</i>	<i>Part Number</i>	<i>Qty.</i>	<i>Description</i>
1	116-7551	1	Brake Handle ASM	15	116-2643	2	Decal-Wheel Nut Torque
2	116-0629	2	Screw-CARR	17	116-8963	2	Cable-Brake
3	82-6840	2	Spacer	18	116-1399	2	Locknut
4	60-1730	2	Pin-Clevis	19	3256-24	4	Washer-Flat
5	3272-1	2	Pin-Cotter	22	88-7970	2	Clip
6	116-1746	2	Wheel Hub ASM	23	3296-56	2	Nut-Lock, NI
6:2	116-1696	4	Stud-Wheel	24	116-6397	1	Bracket-Cable
7	127-9510	2	Wheel And Tire ASM	25	32144-10	1	Screw-HWH
7:1	127-9511	1	Wheel	26	32120-18	4	E-Ring
7:2	1-653160	1	Tire	27	116-6182	2	Bracket-Brake, L
7:3	232-27	1	Stem-Valve	28	116-6347	2	Spring-Die
8	242-50	8	Nut-Lug	29	3256-22	4	Washer-Flat
9	109-2889	2	Caliper-Brake	30	32151-86	2	E-Ring
10	109-0958	2	Plate-Mount, Brake	31	116-6348	2	Pin-Brake
11	92-5727	4	Screw-Lock, Patch	32	3334-945	2	Tie-Cable
14	3296-13	2	Nut-Lock, NI	33	104-8300	2	Nut-Flange, NI

Parking Brake Handle Assembly No. 116-7551

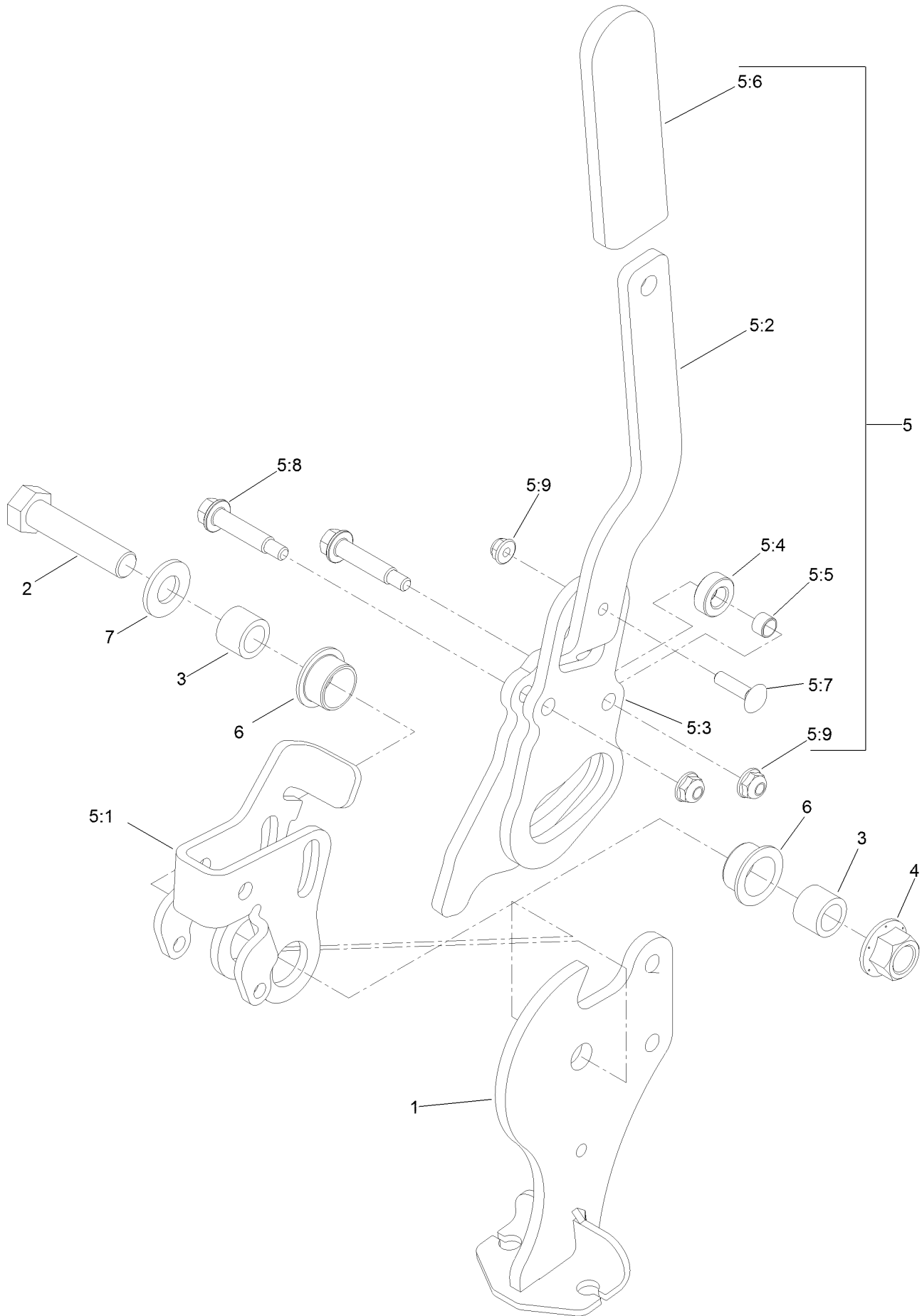

Parking Brake Handle Assembly No. 116-7551 (continued)

<i>Ref.</i>	<i>Part Number</i>	<i>Qty.</i>	<i>Description</i>	<i>Ref.</i>	<i>Part Number</i>	<i>Qty.</i>	<i>Description</i>
1	116-7263	1	Pivot-Brake	5:4	116-6846	1	Roller-Brake
2	325-9	1	Screw-HH	5:5	116-6852	1	Bearing-Sleeve
3	116-5384	2	Spacer	5:6	1-633268	1	Grip-Lever
4	99-5107	1	Nut-Lock	5:7	3229-2	1	Screw-CARR
5	116-6860	1	Handle ASM	5:8	116-6876	2	Screw-Shoulder
5:1	116-6856	1	Bellcrank-Brake	5:9	104-7201	3	Nut-HF
5:2	116-6857	1	Handle-Brake	6	109-8054	2	Bushing-Flange
5:3	116-6858	1	Plate-Handle	7	3256-26	1	Washer-Flat

Fuel Tank Mounting Assembly

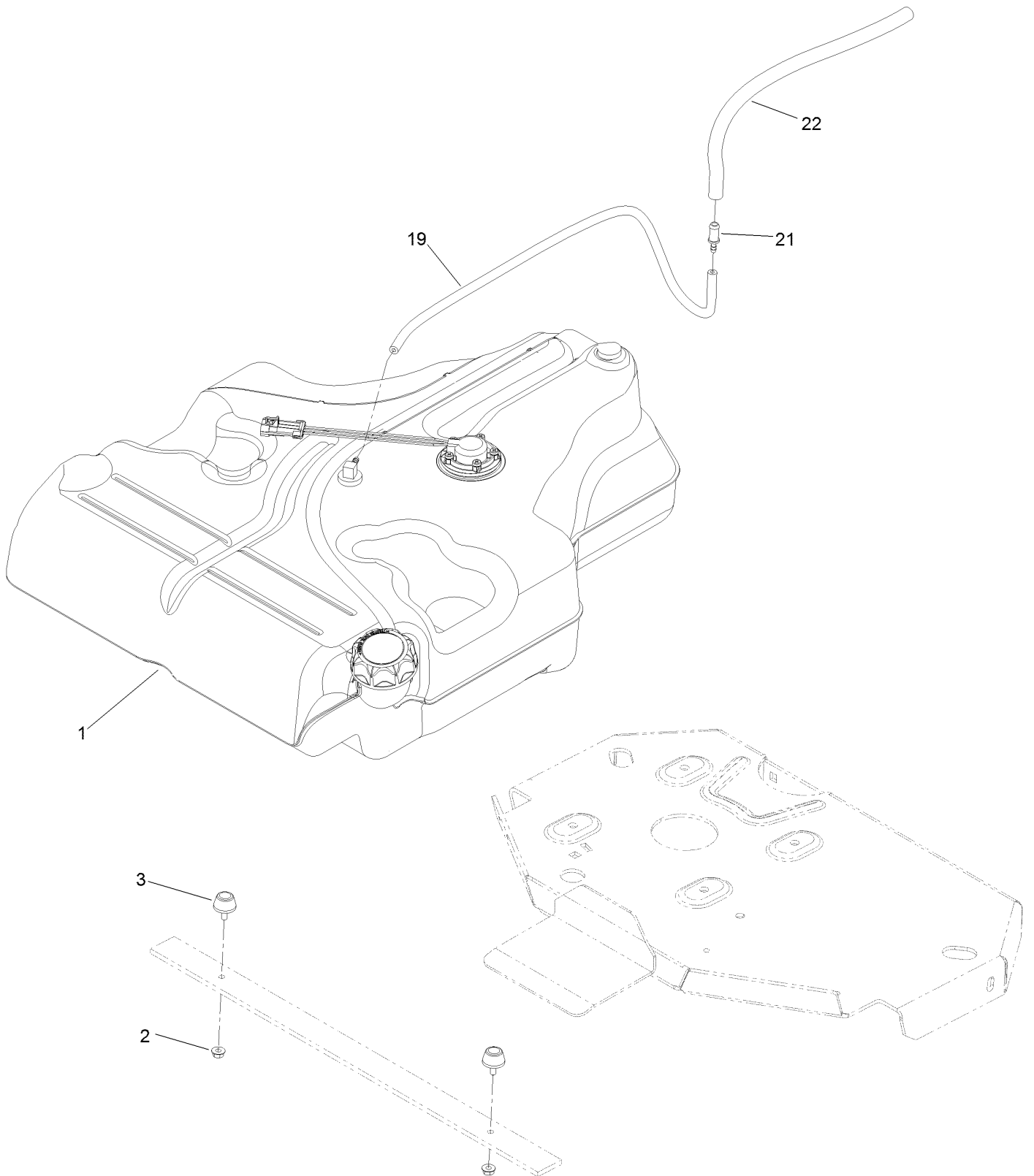

Fuel Tank Mounting Assembly (continued)

<i>Ref.</i>	<i>Part Number</i>	<i>Qty.</i>	<i>Description</i>	<i>Ref.</i>	<i>Part Number</i>	<i>Qty.</i>	<i>Description</i>
1	116-3978	1	Fuel Tank ASM	19	110-8751	1	Hose-Fuel
2	3218-1	2	Nut-Jam	21	98-2952	1	Fitting-Straight
3	116-6380	2	Bumper-Rubber (W/ Stud)	22	116-4344	1	Hose-Fuel

Fuel Tank Assembly No. 116-3978

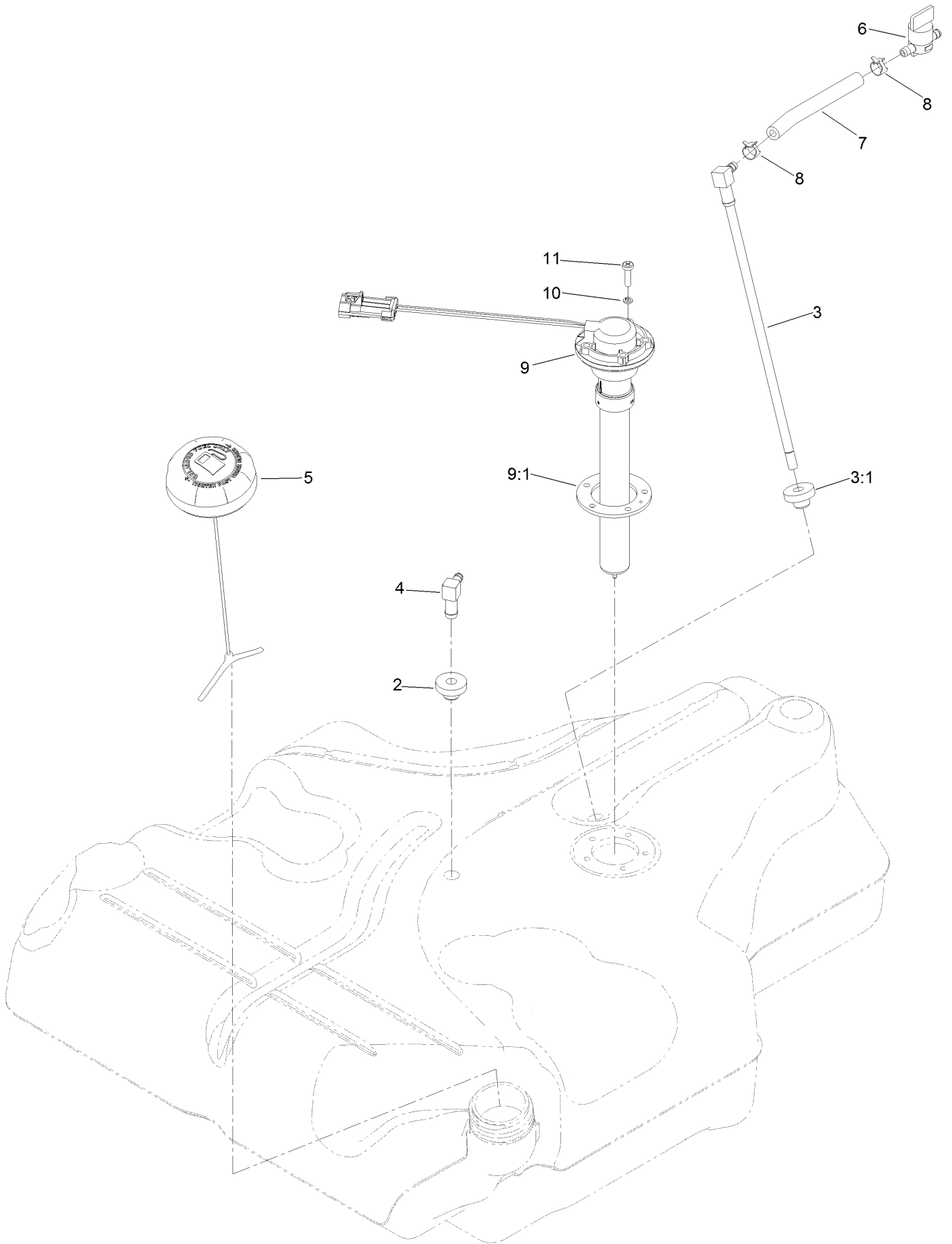

Fuel Tank Assembly No. 116-3978 (continued)

<i>Ref.</i>	<i>Part Number</i>	<i>Qty.</i>	<i>Description</i>	<i>Ref.</i>	<i>Part Number</i>	<i>Qty.</i>	<i>Description</i>
2	46-6560	2	Bushing	7	109-0650	1	Hose-Fuel
3	116-2459	1	Fuel Line Kit (With Grommet)	8	2412-98	2	Clamp-Hose
3:1	46-6560	1	Bushing	9	116-1981	1	Sender-Fuel
4	116-2288	1	Fitting-90 Elbow	9:1	109-9620	1	Gasket-Sender, Fuel
5	126-1789	1	Cap-Fuel, Ratcheting	10	3253-17	5	Washer-Lock
6	1-603770	1	Valve-Fuel	11	9107944	5	Screw-Pan

Seat Mount Assembly

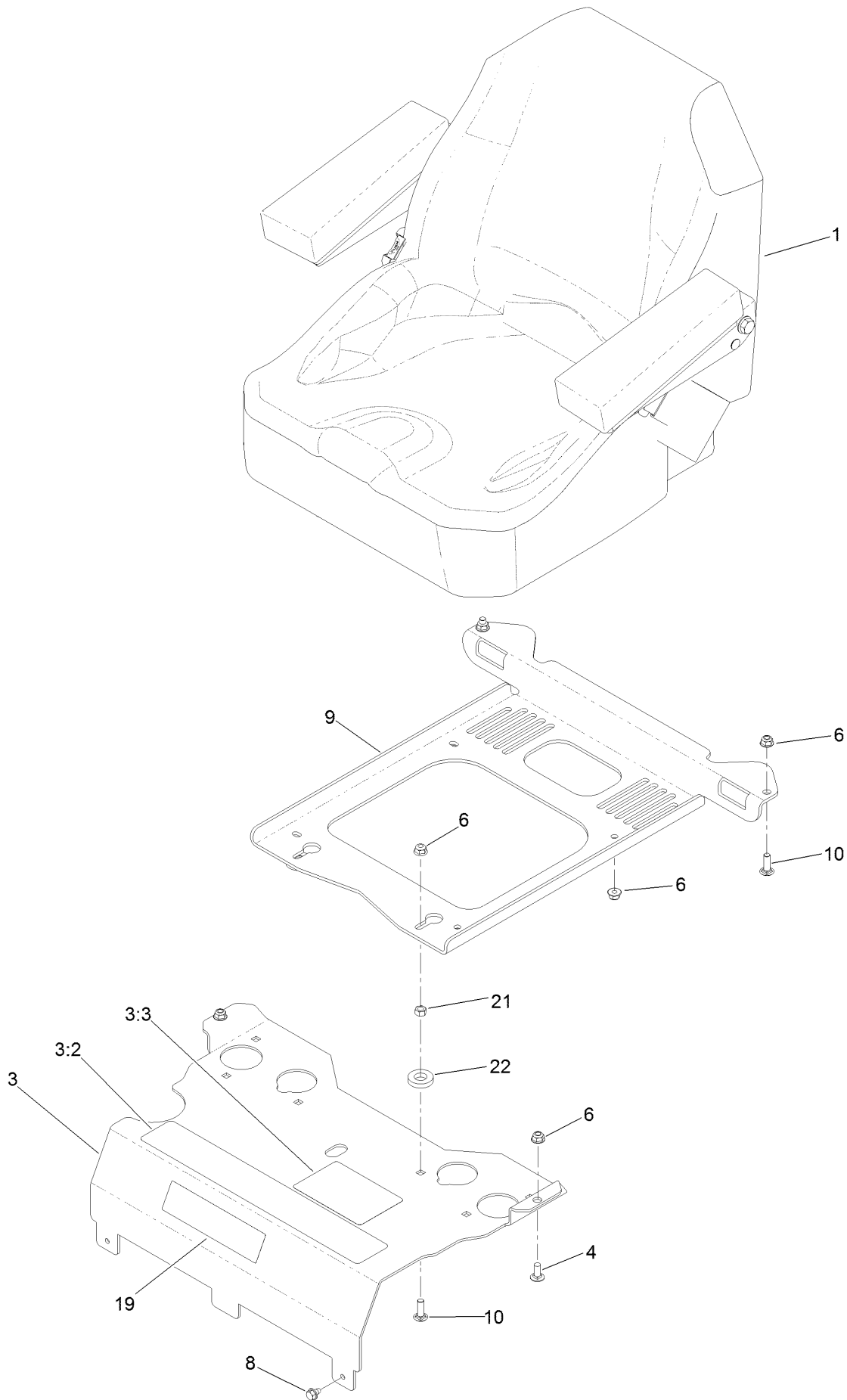

Seat Mount Assembly (continued)

<i>Ref.</i>	<i>Part Number</i>	<i>Qty.</i>	<i>Description</i>	<i>Ref.</i>	<i>Part Number</i>	<i>Qty.</i>	<i>Description</i>
1	116-0038	1	Seat ASM	8	9266934	2	Screw
3	125-9385	1	Seat Mount ASM	9	116-0192-03	1	Plate-Support, Seat
3:2	109-7069	1	Decal-Console	10	3230-22	4	Screw-CARR
3:3	125-9382	1	Decal-Service Aid	19	114-5878	1	Decal
4	3230-23	2	Screw-CARR	21	3217-6	2	Nut-Hex
6	104-8300	10	Nut-Flange, NI	22	1-323539	2	Spacer

Seat Assembly No. 116-0038

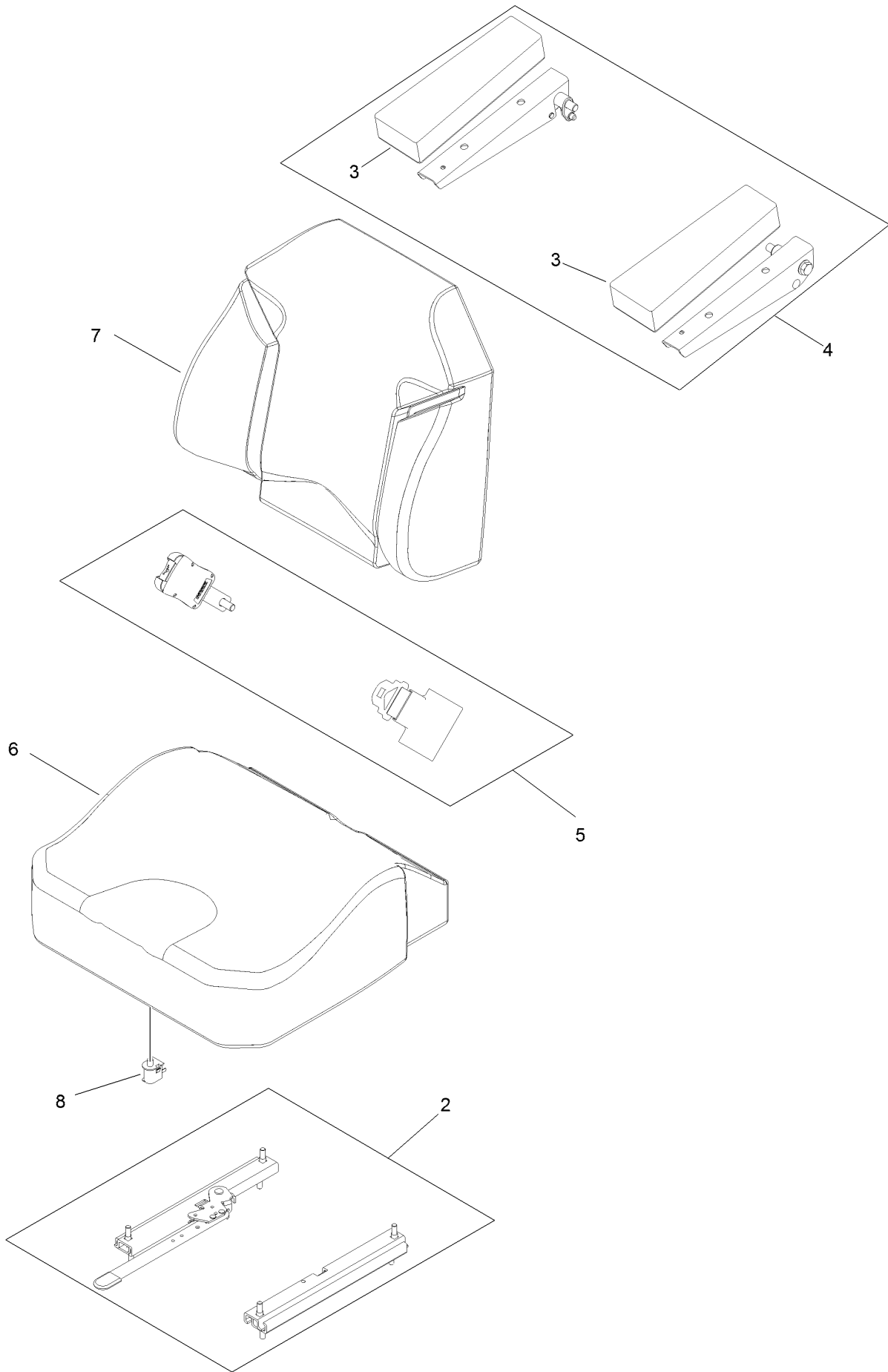

Seat Assembly No. 116-0038 (continued)

<i>Ref.</i>	<i>Part Number</i>	<i>Qty.</i>	<i>Description</i>
2	109-9801	1	Seat Track Set
3	109-9814	1	Arm Rest Pads Set
4	109-9816	1	Arm Rest Kit
5	109-9805	1	Seat Belt Kit

<i>Ref.</i>	<i>Part Number</i>	<i>Qty.</i>	<i>Description</i>
6	109-9819	1	Cover-Cushion
7	109-9810	1	Cover-Back
8	82-2190	1	Switch-Bail

Motion Control Assembly (continued)

<i>Ref.</i>	<i>Part Number</i>	<i>Qty.</i>	<i>Description</i>	<i>Ref.</i>	<i>Part Number</i>	<i>Qty.</i>	<i>Description</i>
1	116-0880	1	RH Motion Control And Bushing ASM	14	109-6589	1	RH Steering Handle ASM
1:2	109-8054	4	Bushing-Flange	14:1	109-5668	1	Grip-Control, Lever
2	116-0881	1	LH Motion Control And Bushing ASM	15	109-6590	1	LH Steering Handle ASM
2:2	109-8054	4	Bushing-Flange	15:1	109-5668	1	Grip-Control, Lever
3	116-0648	2	Screw-HH, Thread Locking ●	16	104-8301	4	Nut-Flange, NI
4	109-4581	2	Arm-Control, Pump	17	323-7	4	Screw-HH
5	9080046	2	Screw-HH ●	18	109-5575	2	Spring-Leaf
6	1-303435	2	Washer-Spring	19	109-8107	2	Pump Linkage Rear ASM
7	116-0027	2	Damper-Control, Motion	19:2	3219-2	2	Nut-Hex
8	104-8300	8	Nut-Flange, NI	19:3	1-323245	2	Spring-Compression
9	3230-2	2	Bolt-CARR	19:4	1-633152	1	Balljoint-LH
10	109-5891	2	Hub-Threaded	19:5	1-543017	1	Balljoint-RH
11	325-12	2	Screw-HH	20	109-9505	4	Washer-Spring
12	116-0039	1	Lever-Control Motion, RH	21	3256-6	2	Washer-Flat
13	116-0040	1	Lever-Control Motion, LH	22	32128-56	2	Nut-HF
				23	3256-23	2	Washer-Flat
				24	3218-5	2	Nut-Jam
				25	115-1794	2	Screw-HHF

● Use Pro-Lock, Nut Type (P/N 1-840022, .5ml tube) on threads.

Fender, Console and Control Assembly

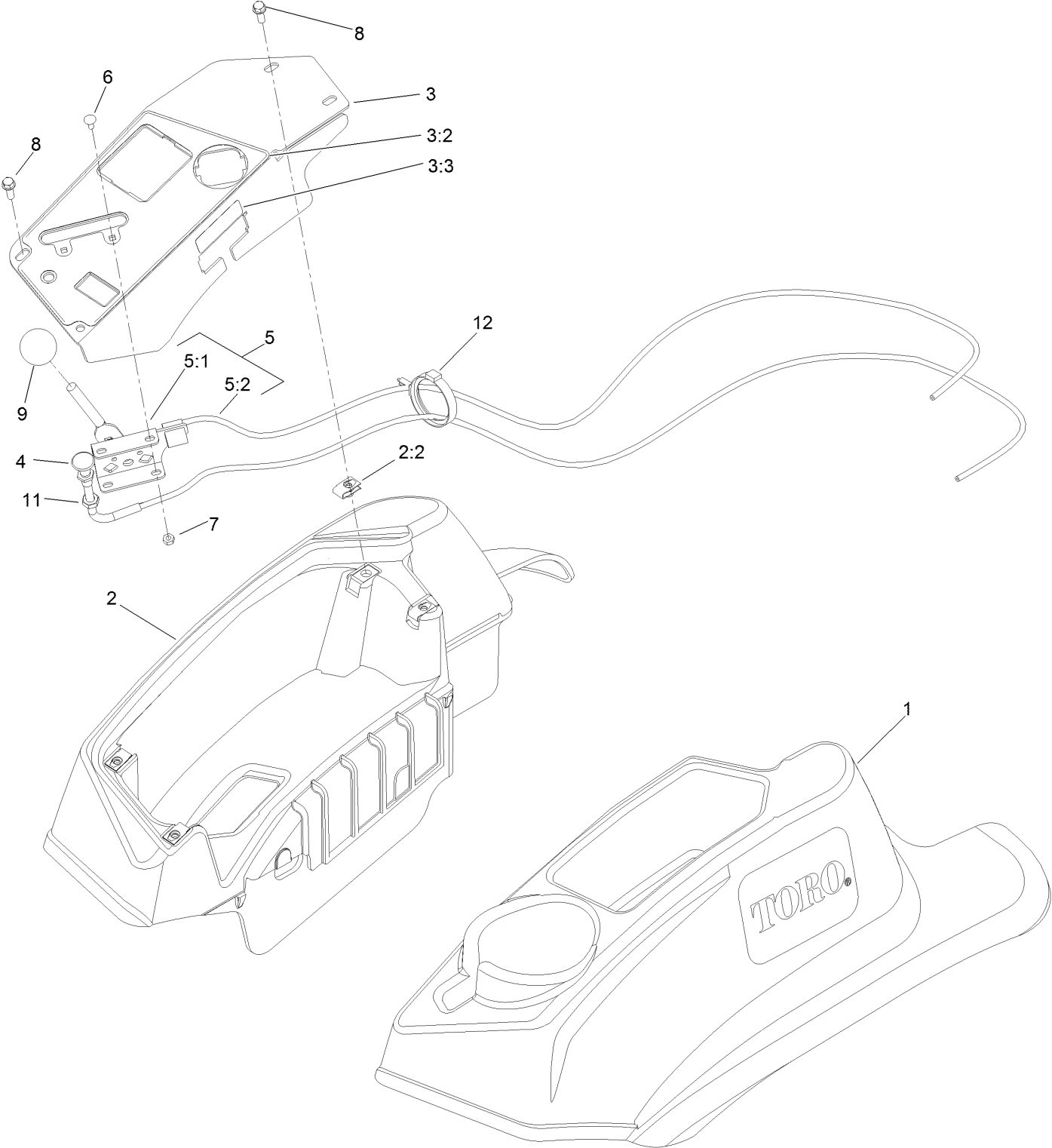

Fender, Console and Control Assembly (continued)

<i>Ref.</i>	<i>Part Number</i>	<i>Qty.</i>	<i>Description</i>	<i>Ref.</i>	<i>Part Number</i>	<i>Qty.</i>	<i>Description</i>
1	119-2602	1	LH Console ASM	5:1	112-2334	1	Lever-Throttle
2	119-2603	1	RH Console ASM	5:2	110-5728	1	Cable-Throttle
2:2	107069	4	Clip	6	1-807513	2	Bolt-CARR
3	119-6663	1	Control Panel ASM	7	3296-2	2	Nut-Lock, NI
3:2	121-7551	1	Decal-Control Panel	8	32105-15	4	Screw-HWH
3:3	114-4466	1	Decal-Fuses	9	1-603175	1	Knob-Ball
4	115-2753	1	Control-Choke	11	3220-3	1	Nut-HJ
5	110-5727	1	Throttle Control ASM	12	117-7817	1	Clamp-Harness

Electrical Assembly

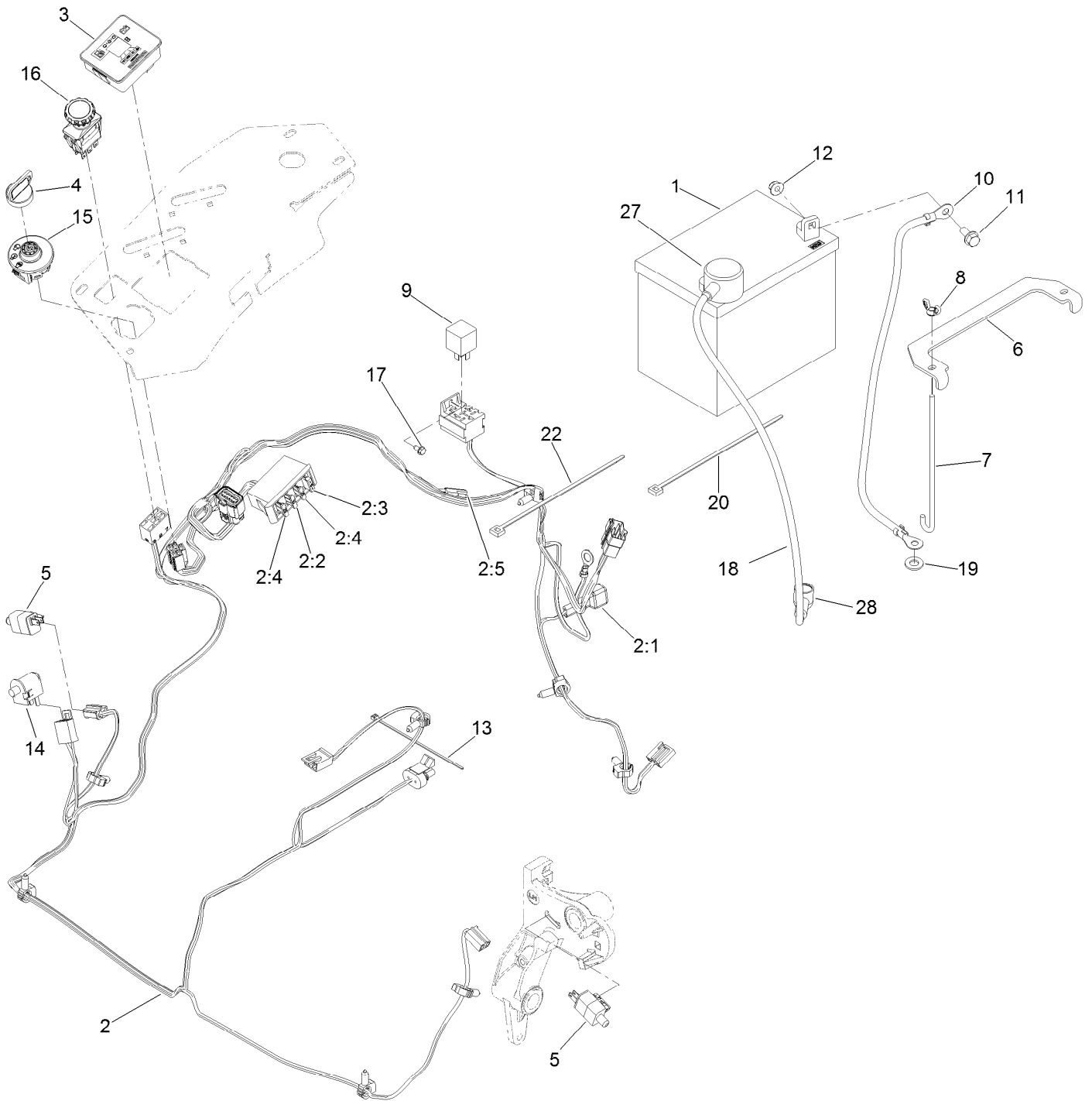

Electrical Assembly (continued)

<i>Ref.</i>	<i>Part Number</i>	<i>Qty.</i>	<i>Description</i>	<i>Ref.</i>	<i>Part Number</i>	<i>Qty.</i>	<i>Description</i>
1	104-8162	1	Battery-Dry	10	114-1218	1	Cable-Battery, Negative
2	116-6009	1	Harness-Wire, Main ●	11	3234-5	2	Screw-HHF
2:1	103-3895	1	Diode-Tvs	12	104-8300	2	Nut-Flange, NI
2:2	218-578	1	Fuse-Blade, 10 Amp	13	1-303287	3	Tie-Cable
2:3	109355	1	Fuse-Blade, 15 Amp	14	82-2190	1	Switch-Bail
2:4	109102	2	Fuse-Blade, 25 Amp	15	117-2221	1	Switch-Ignition
2:5	116-0053	1	Cap-Plug	16	116-0124	1	Switch-PTO, 10A
3	117-3882	1	Fuel/Hour Meter ASM	17	104-2065	1	Screw-HWH
4	63-8360	1	Key-Ignition (W/Shield)	18	115-3864	1	Cable-Battery, Positive
5	110-6765	2	Switch-Single Pole No	19	3256-24	1	Washer-Flat
6	116-0042-03	1	Strap-Tie Down, Battery	20	1-303335	1	Tie-Plastic
7	1-633651	2	Bolt-Holddown	22	1-303335	1	Tie-Plastic
8	1-543792	2	Wingnut	27	109-2407	1	Insulator-Battery
9	1-643275	1	Relay	28	1-543393	1	Insulator-Solenoid

● Use dielectric grease on all unsealed connectors and terminals only. Do not apply in sealed connectors.

Deck Lift Assembly (continued)

<i>Ref.</i>	<i>Part Number</i>	<i>Qty.</i>	<i>Description</i>	<i>Ref.</i>	<i>Part Number</i>	<i>Qty.</i>	<i>Description</i>
1	109-7952	2	Deck Strut ASM	16	109-7438	1	HOC ASM
1:2	109-5009	2	Bushing-Suspension, Rubber	17	109-9065	1	Screw-HH
1:3	109-5010	2	Spacer	18	3296-23	1	Nut-Lock, NI
2	109-5013	1	Panhard Rod ASM	19	3231-2	2	Bolt-CARR
2:2	109-5009	2	Bushing-Suspension, Rubber	20	116-2217-03	1	Cross Shaft-Front
2:3	109-5010	2	Spacer	21	116-0756	4	Deck Lift Chain ASM
3	86-1990	6	Washer-Thrust	21:1	1-633447	1	Chain-Lift, Deck
4	99-5107	12	Nut-Lock	21:2	109-9065	1	Screw-HH
5	325-12	2	Screw-HH	21:3	32128-37	1	Nut-HF
6	325-17	1	Screw-HH	22	116-0559	1	Bolt-TAP
7	3233-34	3	Screw-CARR	23	32128-37	6	Nut-HF
8	116-0818-03	2	Support-Cross Shaft, Rear Bearing	24	109-9066	4	Yoke-Adjust, Deck
9	109-7173	2	Bearing-Cross Shaft, Rear	25	322-47	4	Screw-HH
10	3231-4	2	Screw-CARR	26	3218-2	8	Nut-Jam
11	104-8301	12	Nut-Flange, NI	27	116-0459-03	1	Lift-Deck, Rear
12	109-9409	2	Support-Cross Shaft, Front Bearing	28	116-0780	2	Screw-HHF, Shoulder
13	109-9410	2	Bearing-Cross Shaft, Front	29	116-0797-03	1	Link-Lift, Deck
14	116-1700	4	Bolt-CARR	30	116-0886	1	Extension Spring ASM
15	109-9840	4	Screw-Shoulder, HHF	31	116-5584	1	Pin-HOC
				32	116-1919-01	1	Lever-Foot
				33	3256-28	2	Washer-Flat
				34	92-7674	1	Bolt-Shoulder
				39	3231-5	4	Screw-CARR

Height-of-Cut Assembly No. 109-7438

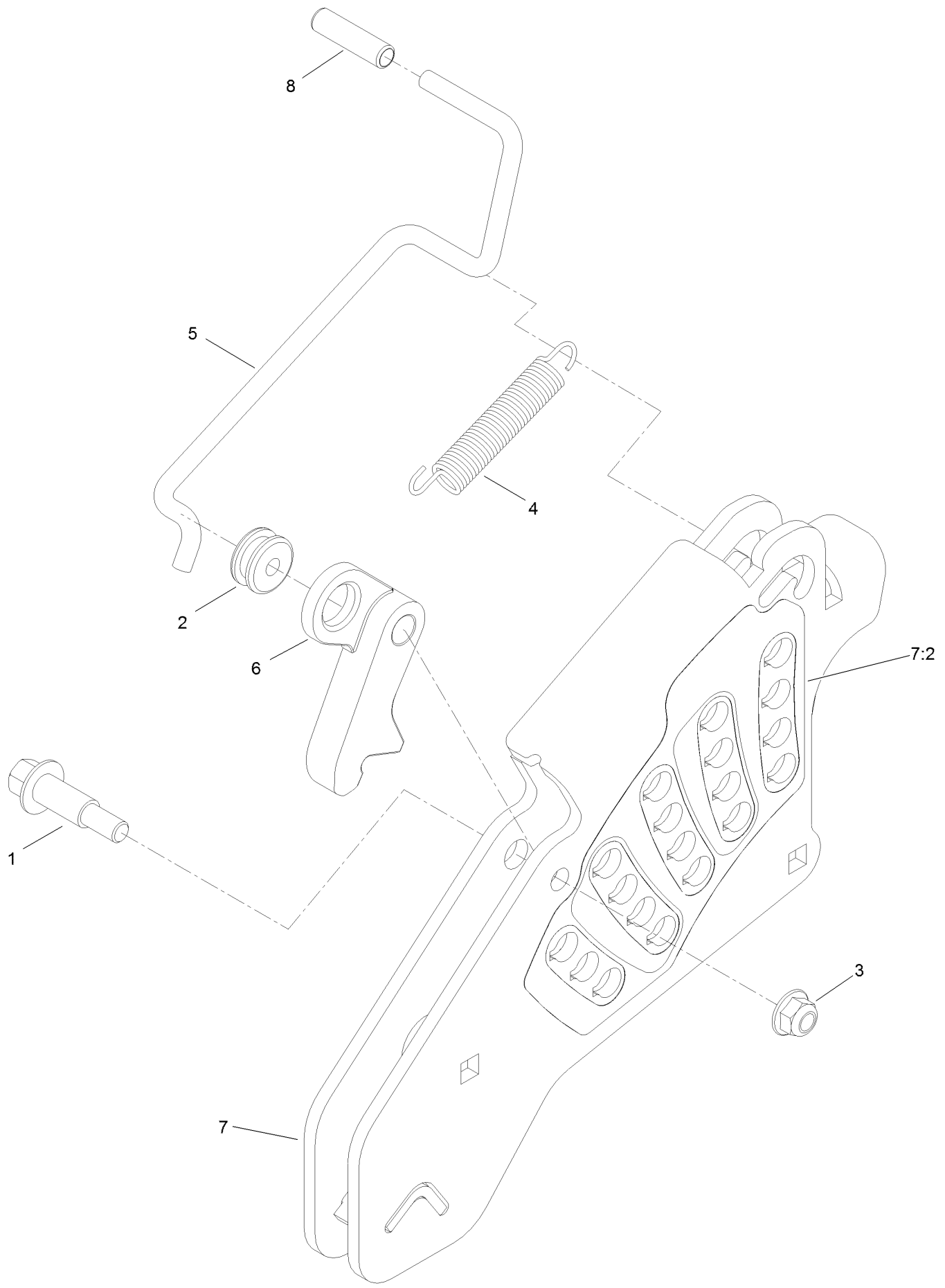

Height-of-Cut Assembly No. 109-7438 (continued)

<i>Ref.</i>	<i>Part Number</i>	<i>Qty.</i>	<i>Description</i>	<i>Ref.</i>	<i>Part Number</i>	<i>Qty.</i>	<i>Description</i>
1	62-1330	1	Bolt-Shoulder	6	116-0118	1	Pawl-Transport, HOC
2	109-7130	1	Grommet	7	109-7335	1	HOC Plate ASM
3	104-8301	1	Nut-Flange, NI	7:2	116-0752	1	Decal-HOC
4	109-7124	1	Spring-Extension	8	109-8250	1	Grip-Lever
5	109-7128	1	Rod-Lock, Transport				

Engine, Clutch and Muffler Assembly

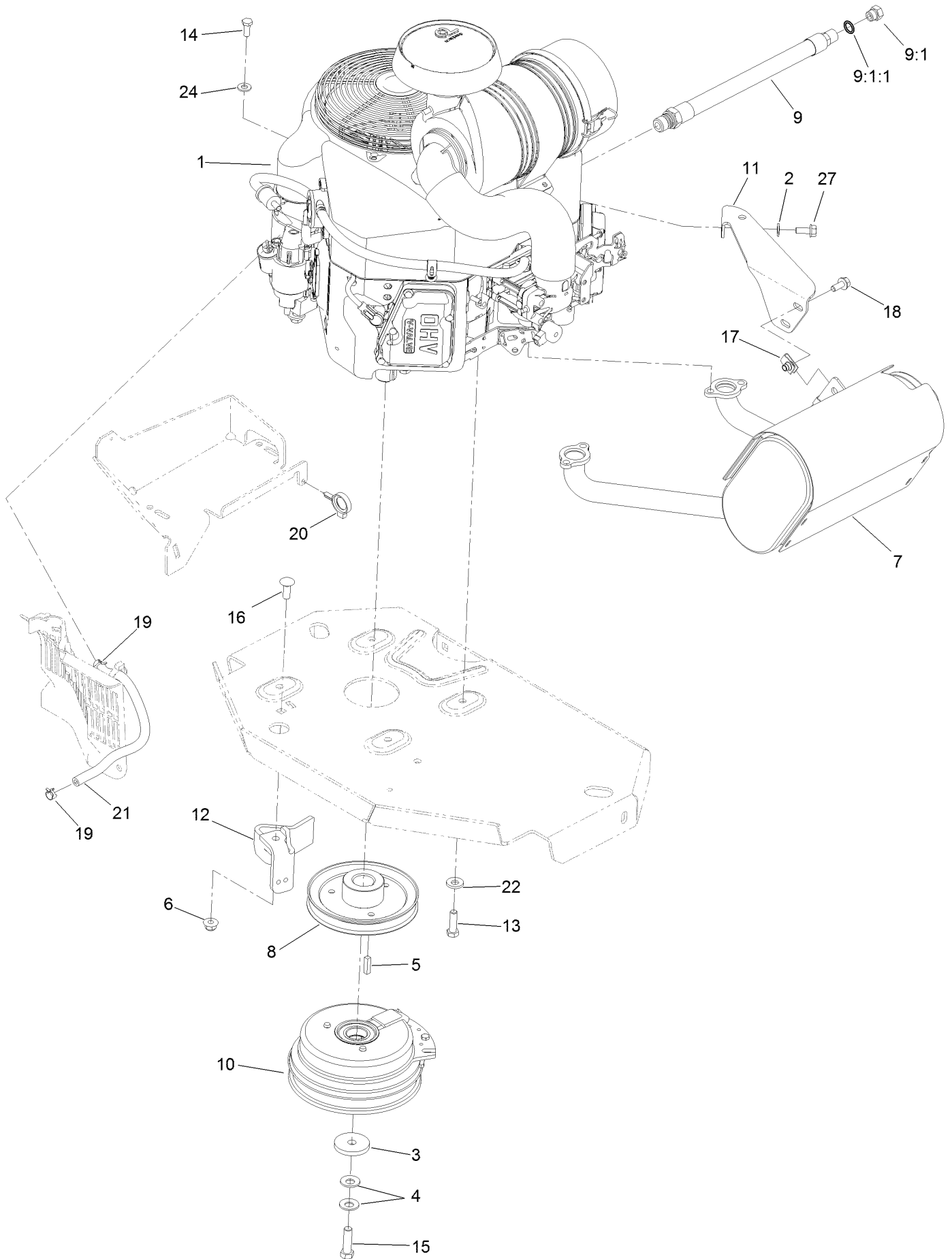

Engine, Clutch and Muffler Assembly (continued)

<i>Ref.</i>	<i>Part Number</i>	<i>Qty.</i>	<i>Description</i>	<i>Ref.</i>	<i>Part Number</i>	<i>Qty.</i>	<i>Description</i>
1		1	Engine-Kawasaki, Fx651V-S10-R ●■	11	116-1435	1	Bracket-Muffler
2	1-303334	1	Washer-Spring	12	116-2612-01	1	Clutch-Anchor
3	109-6919	1	Washer-Clutch	13	323-7	4	Screw-HH
4	1-603610	2	Washer-Spring	14	33114-020	1	Screw-HH
5	1-807259	1	Key	15	109-9761	1	Screw-HH ◆
6	104-8301	1	Nut-Flange, NI	16	3231-22	1	Screw-CARR
7	116-1715	1	Muffler	17	94-2413	2	U-Nut
8	116-1946	1	Sheave-Pump, Drive	18	3234-5	2	Screw-HHF
9	116-4924	1	Engine Oil Drain Hose ASM ▲	19	2412-98	2	Clamp-Hose
9:1	353-508	1	Plug-HH	20	105-1853	1	Clamp-Hose
9:1:1	237-42	1	O-Ring	21	109-0296	1	Hose-Fuel
10	116-1947	1	Clutch	22	98-5975	4	Washer-Belleville
				24	33094-00	1	Washer-Plain
				27	95-4184	1	Screw-HHF

● Not serviced separately

▲ Use a Teflon Pipe Sealant or equivalent on threads.

◆ Use Pro-Lock, Nut Type (P/N 1-840022, .5ml tube) on threads.

■ Obtain parts from www.kawpowerepc.com

Deck Assembly

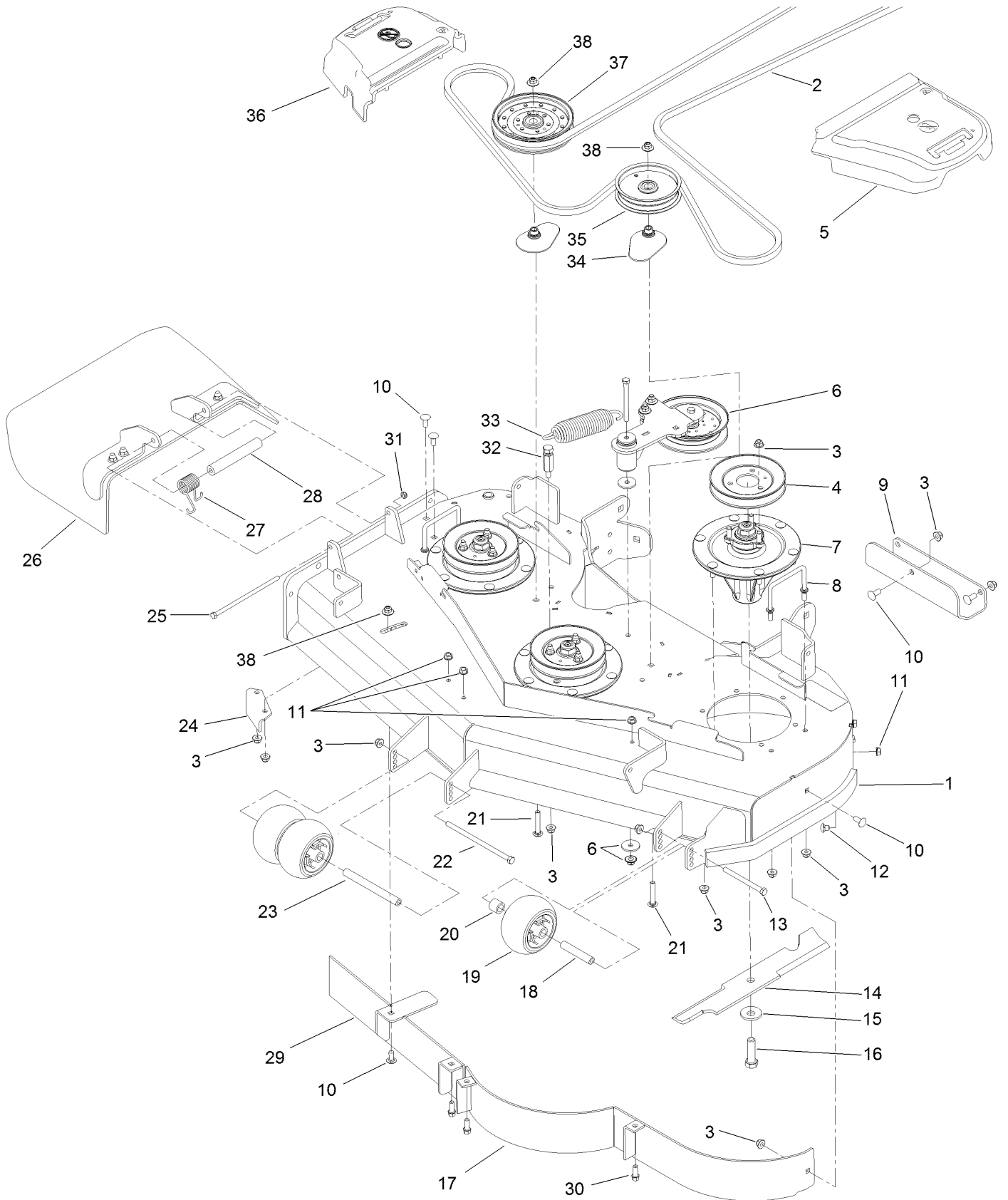

Deck Assembly (continued)

<i>Ref.</i>	<i>Part Number</i>	<i>Qty.</i>	<i>Description</i>	<i>Ref.</i>	<i>Part Number</i>	<i>Qty.</i>	<i>Description</i>
1	114-5805	1	Deck Decal ASM	20	98-7913	1	Tube-Spacer
2	115-7407	1	Belt-V	21	3231-40	2	Bolt-CARR, Short Neck
3	104-8301	41	Nut-Flange, NI	22	108-5388	1	Screw-HH
4	115-7440	3	Pulley	23	98-5967	1	Spacer-Wheel
5	109-6936	1	Cover-Belt, LH	24	107-8541-01	1	Baffle-Discharge
6		1	Idler Arm ASM ●	25	322-50	1	Screw-HH
7	119-8560	3	Spindle ASM	26	108-2792	1	Rubber Deflector ASM
8	109-6982	2	Wireform-Cover	27	108-4052	1	Spring-Torsion
9	121-7975-01	1	Plate-Skid	28	105-4622	1	Spacer
10	3231-27	8	Screw-CARR	29	115-7455-01	1	Baffle ASM
11	3290-357	6	Nut-HHF, Whiz	30	92-1624	3	Screw-HWH
12	108-5387	3	Screw-CARR	31	3296-47	1	Nut-Lock, NI
13	323-23	1	Screw-HH	32	114-5867	1	Anchor-Spring, Tall
14	107-3192-03	3	Blade-16.5 Inch (High Flow)	33	116-6317	1	Spring-Extension
15	103-0865	3	Washer-Blade Bolt, Heavy	34	109-2872	2	Spacer-Pulley
16	51-4060	3	Screw-Blade	35	116-4665	1	Idler-Pulley, Flat
17	114-5862-01	1	Baffle	36	109-6935	1	Cover-Belt, RH
18	98-7912	1	Tube-Spacer	37	116-4670	1	Pulley-Idler, Flat
19	1-603299	3	Roller-Scalp, Anti	38	109-6658	3	Nut-Flange, NI

● Not serviced separately

Deck Decal Assembly No. 114-5805

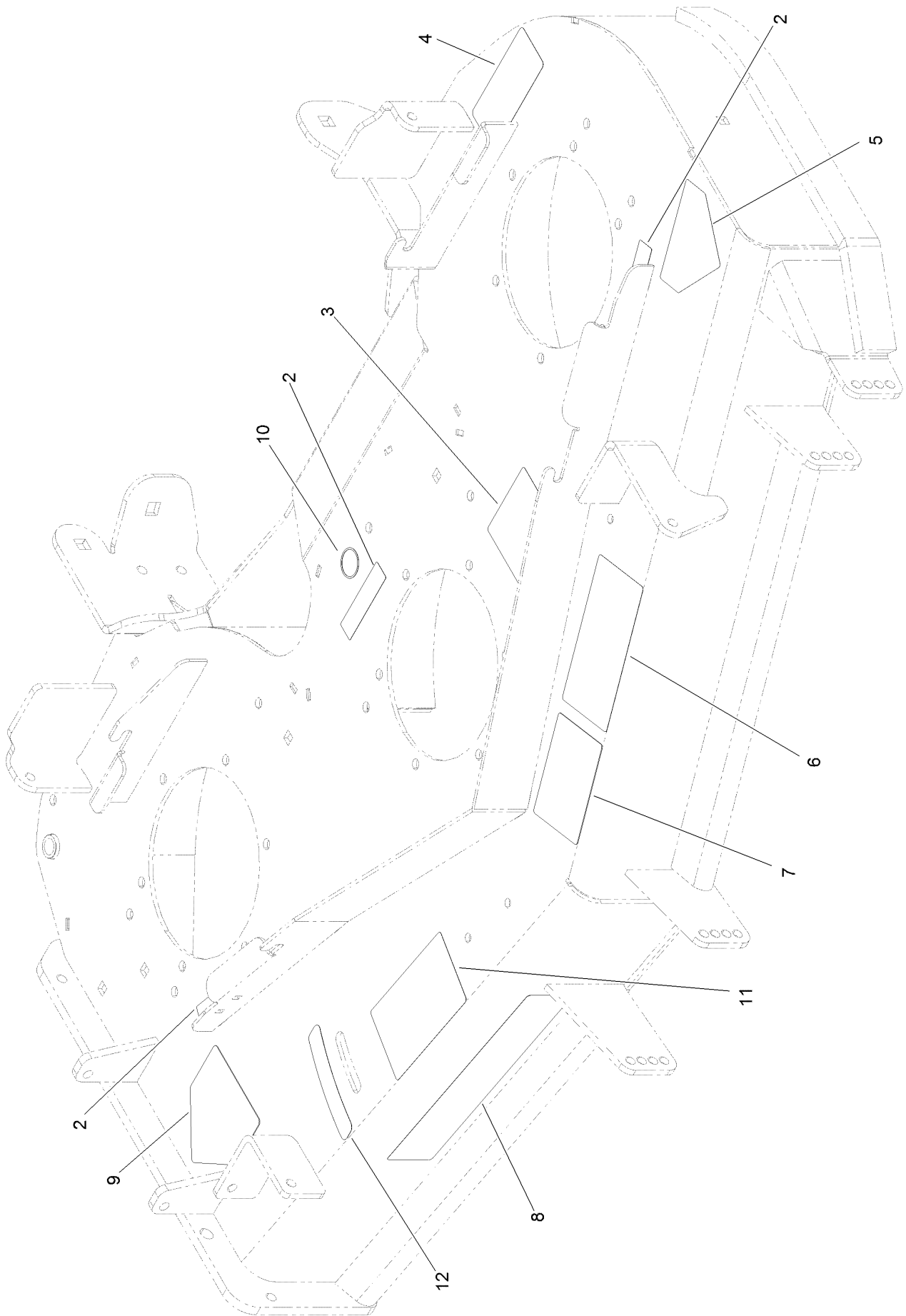

Deck Decal Assembly No. 114-5805 (continued)

<i>Ref.</i>	<i>Part Number</i>	<i>Qty.</i>	<i>Description</i>	<i>Ref.</i>	<i>Part Number</i>	<i>Qty.</i>	<i>Description</i>
2	98-5954	3	Decal-Cover, Missing	7	105-7798	1	Decal-Scalp, Anti
3	115-7445	1	Decal-Routing, Deck Belt	8	107-1690	1	Decal
4	68-8340	1	Decal-Torque	9	54-9220	1	Decal-Danger
5	1-403005	1	Decal-Danger	10	58-6520	1	Decal-Grease
6	66-1340	1	Decal-Danger, Thrown Object	11	110-2068	1	Decal-Adjustment, Baffle
				12	110-2067	1	Decal-Setting, Baffle

Idler Assembly

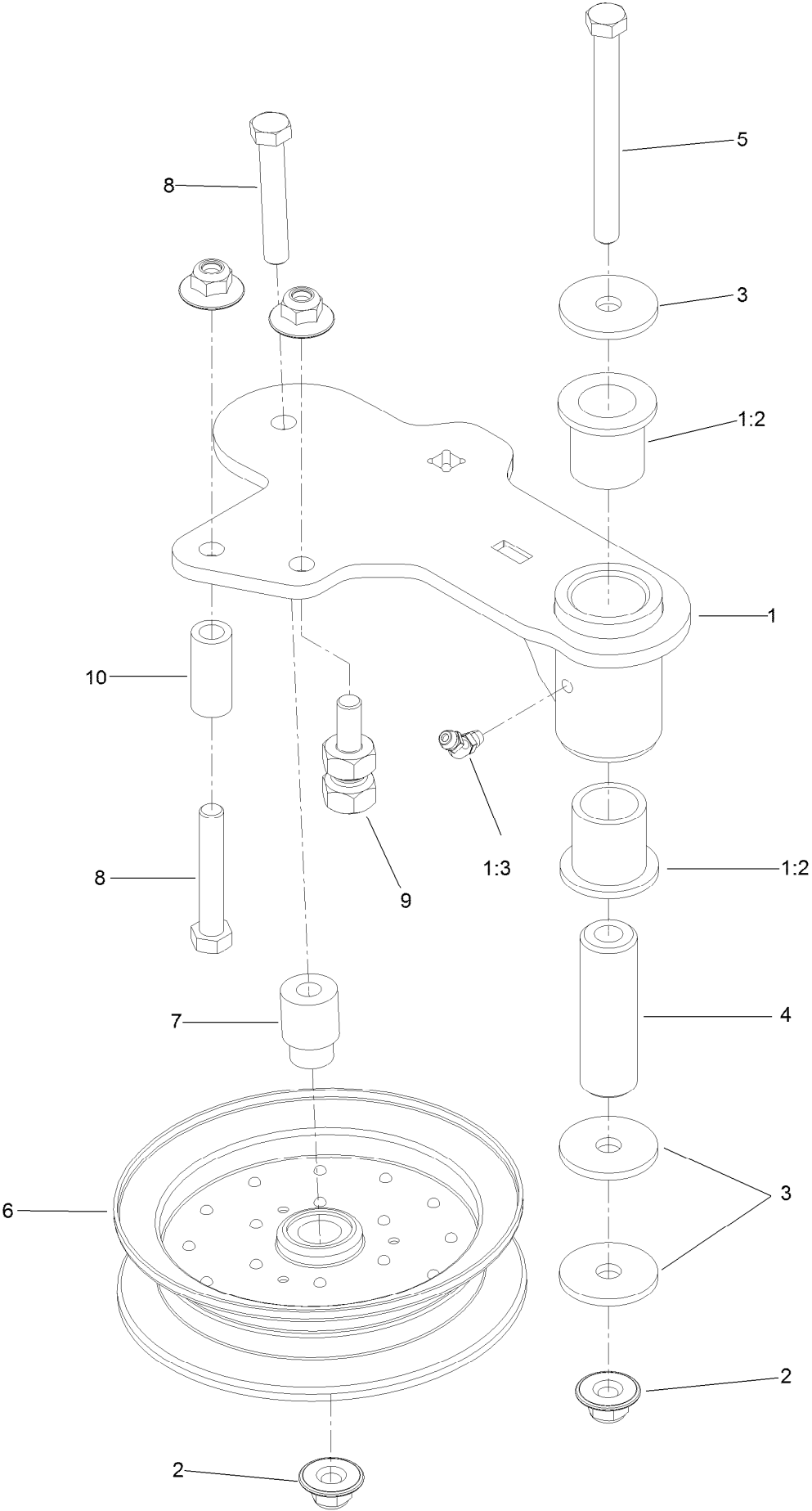

Idler Assembly (continued)

<i>Ref.</i>	<i>Part Number</i>	<i>Qty.</i>	<i>Description</i>	<i>Ref.</i>	<i>Part Number</i>	<i>Qty.</i>	<i>Description</i>
1	114-5870	1	Idler Arm ASM	5	98-5961	1	Screw-HH
1:2	1-303514	2	Bearing-Flanged	6	116-4668	1	Idler-Pulley, Flanged
1:3	1481	1	Fitting-Grease	7	112-4212	1	Mount-Pulley
2	109-6658	4	Nut-Flange, NI	8	323-11	2	Screw-HH
3	1-213069	3	Washer	9	114-5866	1	Anchor-Spring, Short
4	114-5848	1	Spacer-Plain	10	104-0151	1	Spacer

Spindle Assembly No. 119-8560

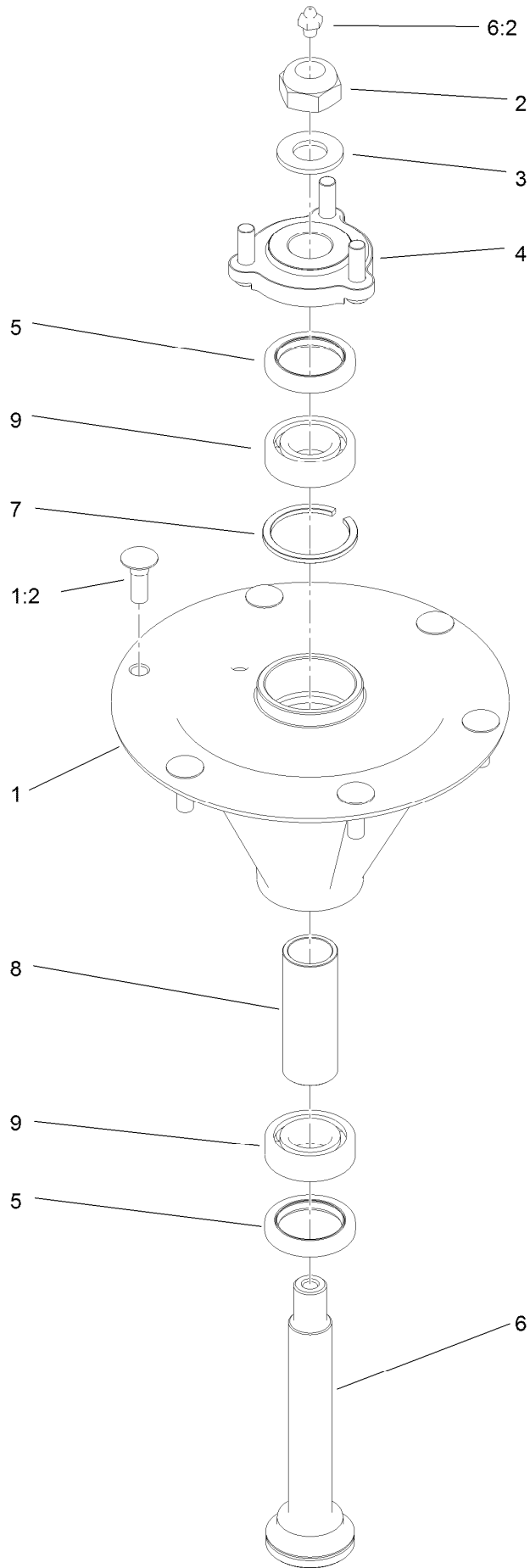

Spindle Assembly No. 119-8560 (continued)

<i>Ref.</i>	<i>Part Number</i>	<i>Qty.</i>	<i>Description</i>	<i>Ref.</i>	<i>Part Number</i>	<i>Qty.</i>	<i>Description</i>
1		1	Spindle Housing And Studs ASM ●	5	253-133	2	Seal-Oil
1:2	114-8195	6	Bolt-Ribbed Neck	6	119-8527	1	Shaft-Spindle
2	3296-67	1	Nut-Lock, NI	6:2	302-2	1	Fitting-Grease
3	92-5836	1	Washer	7	119-8532	1	Snap Ring
4	117-6172	1	Spindle Hub ASM	8	117-6184	1	Spacer
				9	119-8558	2	Bearing-Noseal

● Not serviced separately

Rubber Deflector Assembly No. 108-2792

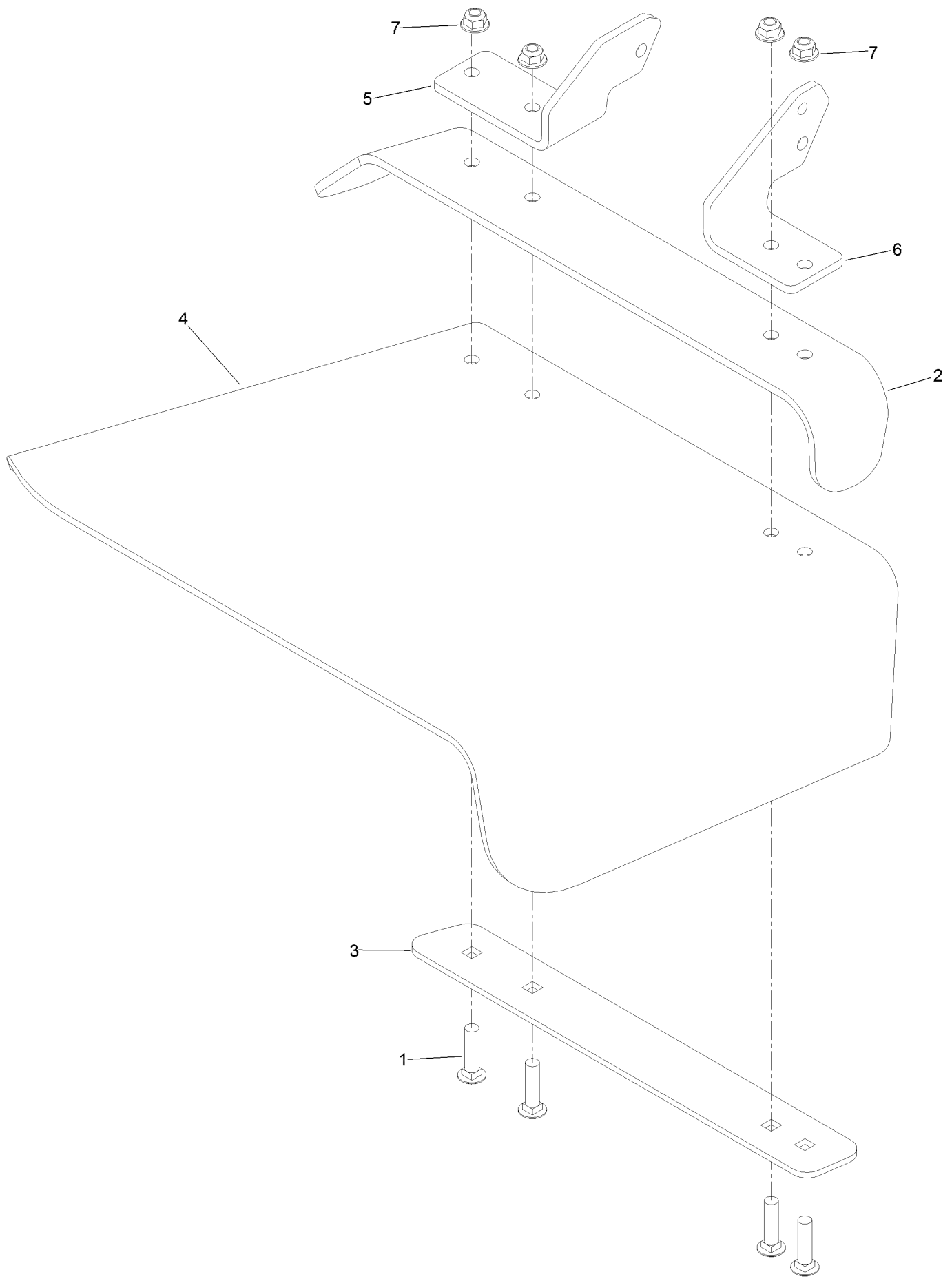

Rubber Deflector Assembly No. 108-2792 (continued)

<i>Ref.</i>	<i>Part Number</i>	<i>Qty.</i>	<i>Description</i>	<i>Ref.</i>	<i>Part Number</i>	<i>Qty.</i>	<i>Description</i>
1	3231-4	4	Screw-CARR	5	108-4059-01	1	Plate-Hinge, Rear
2	106-3246-01	1	Deflector	6	106-3253-01	1	Plate-Hinge, Front
3	106-3248-03	1	Strap-Discharge	7	104-8301	4	Nut-Flange, NI
4	108-5029	1	Deflector-Rubber				

Attachments and Accessories

For 74952 Z Master Commercial 3000 Series Riding Mower with 48in TURBO FORCE Side Discharge Mower

Product Name	Model/Part
Standard High Lift Blade.....	107-3192-03
Blade-Low Flow, 16.5in.....	107-3193-03
Blade-Mid Flow, 16.5in	107-3194-03
Blade-Atomic, 16.5in	107-3195-03
Blade-Recycling, 16.5in.....	107-3196-03
Anti-Scalp Kit (Trim Side).....	108-4140
Hitch Kit	109-9487
Blade-Hi Flow, 16.5in (6 Pack).....	110-0414
Blade-Lo Flow, 16.5in (6 Pack)	110-0415
Blade-Recycler, 16.5in (6 Pack).....	110-0416
Blade-Atomic, 16.5in (6 Pack)	110-0417
Blade-Mid Flow, 16.5in (6 Pack)	110-0418
Hypr-Oil 500 (quart).....	114-4713
Hypr-Oil 500 (gallon).....	114-4714
Hypr-Oil 500-5 (5 gallon).....	114-4715
Bimini Folding Shade Assembly	115-4510
Recycler Kit	115-7466
Roller Striper Kit.....	115-7470
Light Kit.....	116-1154
Operator-Controlled Discharge Chute Kit	117-3600
Deluxe Suspension Seat Kit	117-6174
Z Stand Kit.....	121-4811
Deluxe Seat Kit.....	121-7595
Seat Tilt Frame And Iso Mount Kit.....	121-7596
MVP Belt and Blade Kit.....	127-1634
Toro Deluxe Rider Cover.....	490-7319
Spark Arrestor Screen	75-6880
Blower and Drive Kit	78551
E-Z Vac Twin Bagging System.....	78562
E-Z Vac DFS Collection System	78566
Filter Minder Gauge	99-4664
Trash Holder Kit.....	TC26

Notes:

Notes:

Notes:



Count on it.