



Count on it.

Operator's Manual

**Z Master® Commercial 3000
Series Riding Mower**

**with 60in TURBO FORCE® Side Discharge
Mower**

Model No. 74958—Serial No. 31400001 and Up



⚠ WARNING

CALIFORNIA Proposition 65 Warning

This product contains a chemical or chemicals known to the State of California to cause cancer, birth defects, or reproductive harm.

The engine exhaust from this product contains chemicals known to the State of California to cause cancer, birth defects, or other reproductive harm.

This spark ignition system complies with Canadian ICES-002

Because in some areas there are local, state, or federal regulations requiring that a spark arrester be used on the engine of this machine, a spark arrester is available as an option. If you require a spark arrester, contact your Authorized Toro Dealer.

Genuine Toro spark arresters are approved by the USDA Forestry Service.

Note: It is a violation of California Public Resource Code Section 4442 to use or operate the engine on any forest-covered, brush-covered, or grass-covered land without a spark arrester muffler maintained in working order, or the engine constricted, equipped, and maintained for the prevention of fire. Other states or federal areas may have similar laws.

⚠ WARNING

Removing standard original equipment parts and accessories may alter the warranty, traction, and safety of the machine. Failure to use original Toro parts could cause serious injury or death. Making unauthorized changes to the engine, fuel or venting system, may violate EPA and CARB regulations.

Replace all parts including, but not limited to, tires, belts, blades, and fuel system components with original Toro parts.

The enclosed *Engine Owner's Manual* is supplied for information regarding the US Environmental Protection Agency (EPA) and the California Emission Control Regulation of emission systems, maintenance, and warranty. Replacements may be ordered through the engine manufacturer.

Introduction

This rotary-blade, riding lawn mower is intended to be used by residential homeowners or professional, hired operators. It is designed primarily for cutting grass on well-maintained lawns on residential or commercial properties. It is not designed for cutting brush or for agricultural uses.

Read this information carefully to learn how to operate and maintain your product properly and to avoid injury and product damage. You are responsible for operating the product properly and safely.

You may contact Toro directly at www.Toro.com for product and accessory information, help finding a dealer, or to register your product.

Whenever you need service, genuine Toro parts, or additional information, contact an Authorized Service Dealer or Toro Customer Service and have the model and serial numbers of your product ready. Figure 1 identifies the location of the model and serial numbers on the product. Write the numbers in the space provided.

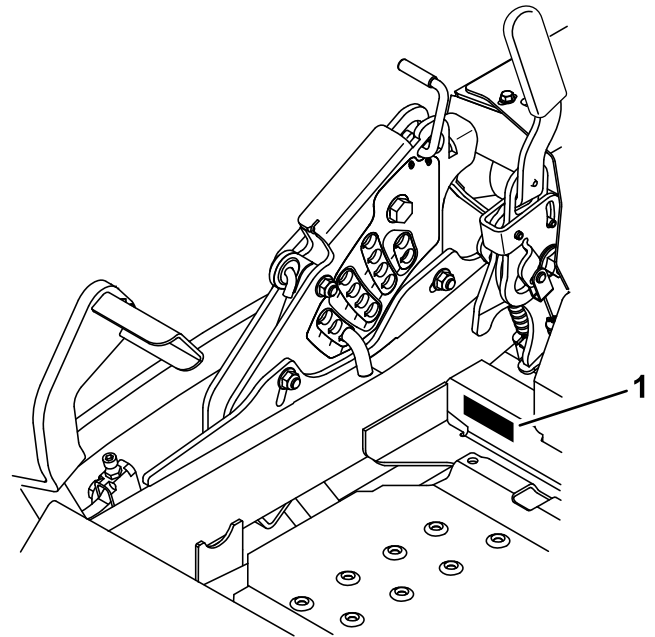

Figure 1

1. Model and serial number location

Model No. _____
Serial No. _____

This manual identifies potential hazards and has safety messages identified by the safety alert symbol (Figure 2), which signals a hazard that may cause serious injury or death if you do not follow the recommended precautions.



Figure 2

1. Safety alert symbol

This manual uses 2 words to highlight information.

Important calls attention to special mechanical information and **Note** emphasizes general information worthy of special attention.

Contents

- Introduction 2
- Safety 4
 - Safe Operating Practices 4
 - Slope Indicator 6
 - Safety and Instructional Decals 7
- Product Overview 11
 - Controls 11
 - Specifications 12
- Operation 13
 - Adding Fuel..... 13
 - Checking the Engine Oil Level 14
 - Breaking In a New Machine 14
 - Using the Rollover Protection System (ROPS) 14
 - Think Safety First..... 15
 - Operating the Parking Brake 15
 - Operating the Mower Blade Control Switch (PTO) 16
 - Operating the Throttle..... 16
 - Operating the Ignition Switch 16
 - Using the Fuel Shut-Off Valve..... 17
 - Starting and Stopping the Engine..... 17
 - The Safety Interlock System..... 18
 - Driving Forward or Backward 19
 - Stopping the Machine 20
 - Adjusting the Height of Cut 20
 - Adjusting the Anti-scalp Rollers..... 21
 - Adjusting the Flow Baffle Cam Locks..... 22
 - Positioning the Flow Baffle..... 23
 - Positioning the Seat 23
 - Using the Drive Wheel Release Valves 24
 - Using the Side Discharge..... 24
 - Loading Machines 24
 - Transporting Machines..... 25
 - Operating Tips 26
- Maintenance 27
 - Recommended Maintenance Schedule(s) 27
 - Lubrication 28
 - Lubricating the Machine..... 28
 - Greasing the Mower 28
 - Lubricate the Caster Wheel Hubs..... 29
 - Engine Maintenance 30
 - Servicing the Air Cleaner 30
 - Servicing the Engine Oil..... 31

- Servicing the Spark Plug 34
- Check the Spark Arrester (if equipped) 35
- Fuel System Maintenance 36
 - Servicing the Electronic Fuel Injection System 36
 - Replacing the Low Pressure Fuel Filter 36
 - Servicing the High Pressure Fuel Filter 36
 - Servicing the Fuel Tank 36
- Electrical System Maintenance 37
 - Servicing the Battery 37
 - Servicing the Fuses 38
- Drive System Maintenance 39
 - Checking the Seat Belt..... 39
 - Checking the Rollover Protection System (ROPS)
 - Knobs..... 39
 - Adjusting the Tracking 39
 - Checking the Tire Pressure 40
 - Checking the Wheel Lug Nuts 40
 - Checking the Wheel Hub Slotted Nut 40
 - Adjusting the Caster Pivot Bearing..... 40
 - Using the Clutch Shim 41
- Cooling System Maintenance 43
 - Cleaning the Engine Screen and Engine Oil Cooler..... 43
 - Cleaning the Engine Cooling Fins and Shrouds..... 43
 - Check and Clean the Hydraulic Units..... 43
- Brake Maintenance 44
 - Adjusting the Parking Brake 44
- Belt Maintenance 45
 - Inspecting the Belts 45
 - Replacing the Mower Belt..... 45
 - Replacing the Hydraulic Pump Drive Belt..... 46
- Controls System Maintenance 47
 - Adjusting the Control Handle Position 47
 - Adjusting the Motion Control Linkage 48
 - Adjusting the Motion-control Damper 49
 - Adjusting the Motion Control Neutral Lock Pivot..... 49
- Hydraulic System Maintenance 50
 - Servicing the Hydraulic System..... 50
- Mower Deck Maintenance..... 52
 - Leveling the Mower Deck 52
 - Servicing the Cutting Blades..... 53
 - Removing the Mower Deck 55
 - Replacing the Grass Deflector..... 56
- Cleaning 57
 - Cleaning Under the Mower 57
 - Waste Disposal..... 57
- Storage 58
 - Cleaning and Storage 58
- Troubleshooting 59
- Schematics 62

Safety

Improper use or maintenance can result in injury. To reduce the potential for injury, comply with these safety instructions and always pay attention to the safety alert symbol, which means **CAUTION, WARNING, or DANGER**-“personal safety instruction.” Failure to comply with the instruction may result in personal injury or death.

This product is capable of amputating hands and feet and throwing objects. Always follow all safety instructions to avoid serious injury or death.

This product is designed for cutting and recycling grass or, when equipped with a grass bagger, for catching cut grass. Any use for purposes other than these could prove dangerous to user and bystanders.

Safe Operating Practices

The following instructions are adapted from ANSI standard B71.4-2012.

Training

- Read the Operator's Manual and other training material. If the operator(s) or mechanic(s) can not read English it is the owner's responsibility to explain this material to them.
- Become familiar with the safe operation of the equipment, operator controls, and safety signs.
- All operators and mechanics should be trained. The owner is responsible for training the users.
- Never let children or untrained people operate or service the equipment. Local regulations may restrict the age of the operator.
- The owner/user can prevent and is responsible for accidents or injuries occurring to people or damage to property.

Preparation

- Evaluate the terrain to determine what accessories and attachments are needed to properly and safely perform the job. Only use accessories and attachments approved by the manufacturer.
- Wear appropriate clothing including hard hat, safety glasses and hearing protection. Long hair, loose clothing or jewelry may get tangled in moving parts.
- Inspect the area where the equipment is to be used and remove all objects such as rocks, toys and wire which can be thrown by the machine.
- Check that operator's presence controls, safety switches and shields are attached and functioning properly. Do not operate unless they are functioning properly.

Operation

- Lightning can cause severe injury or death. If lightning is seen or thunder is heard in the area, do not operate the machine; seek shelter.
- Never run an engine in an enclosed area.
- Only operate in good light, keeping away from holes and hidden hazards.
- Be sure all drives are in neutral and parking brake is engaged before starting engine. Only start engine from the operator's position.
- Be sure of your footing while using this machine, especially when backing up. Walk, don't run. Never operate on wet grass. Reduced footing could cause slipping.
- Slow down and use extra care on hillsides. Be sure to travel side to side on hillsides. Turf conditions can affect the machine's stability. Use caution while operating near drop-offs.
- Slow down and use caution when making turns and when changing directions on slopes.
- Never raise deck with the blades running.
- Never operate with the PTO shield, or other guards not securely in place. Be sure all interlocks are attached, adjusted properly, and functioning properly.
- Never operate with the discharge deflector raised, removed or altered, unless using a grass catcher.
- Do not change the engine governor setting or overspeed the engine.
- Stop on level ground, disengage drives, engage parking brake (if provided), shut off engine before leaving the operator's position for any reason including emptying the catchers or unclogging the chute.
- Stop equipment and inspect blades after striking objects or if an abnormal vibration occurs. Make necessary repairs before resuming operations.
- Keep hands and feet away from the cutting unit.
- Look behind and down before backing up to be sure of a clear path.
- Keep pets and bystanders away.
- Slow down and use caution when making turns and crossing roads and sidewalks. Stop blades if not mowing.
- Be aware of the mower discharge direction and do not point it at anyone.
- Do not operate the mower under the influence of alcohol or drugs.
- Use care when loading or unloading the machine into or from a trailer or truck.
- Use care when approaching blind corners, shrubs, trees, or other objects that may obscure vision.
- Lightning can cause severe injury or death. If lightning is seen or thunder is heard in the area, do not operate the machine; seek shelter.

Rollover Protection System (ROPS) - Use and Maintenance

- The ROPS is an integral and effective safety device. Keep a folding ROPS in the raised and locked position and use the seat belt when operating the machine.
- Lower a folding ROPS temporarily only when absolutely necessary. Do not wear the seat belt when folded down.
- Be aware there is no rollover protection when a folded ROPS is in the down position.
- Be certain that the seat belt can be released quickly in the event of an emergency.
- Check the area to be mowed and never fold down a folding ROPS in areas where there are slopes, drop offs or water.
- Check carefully for overhead clearances (i.e. branches, doorways, electrical wires) before driving under any objects and do not contact them.
- Keep the ROPS in safe operating condition by periodically thoroughly inspecting for damage and keeping all mounting fasteners tight.
- Replace a damaged ROPS. Do not repair or revise.
- **Do not** remove the ROPS.
- Any alterations to a ROPS must be approved by the manufacturer.

Safe handling of fuels

- To avoid personal injury or property damage, use extreme care in handling gasoline. Gasoline is extremely flammable and the vapors are explosive.
- Extinguish all cigarettes, cigars, pipes, and other sources of ignition.
- Use only an approved fuel container.
- Never remove fuel cap or add fuel with the engine running.
- Allow engine to cool before refueling.
- Never refuel the machine indoors.
- Never store the machine or fuel container where there is an open flame, spark, or pilot light such as on a water heater or on other appliances.
- Never fill containers inside a vehicle or on a truck or trailer bed with a plastic liner. Always place containers on the ground away from your vehicle before filling.
- Remove equipment from the truck or trailer and refuel it on the ground. If this is not possible, then refuel such equipment with a portable container, rather than from a fuel dispenser nozzle.
- Keep the nozzle in contact with the rim of the fuel tank or container opening at all times until fueling is complete. Do not use a nozzle lock open device.

- If fuel is spilled on clothing, change clothing immediately.
- Never overfill fuel tank. Replace fuel cap and tighten securely.

Maintenance and storage

- Disengage drives, set parking brake, stop engine and remove key or disconnect spark plug wire. Wait for all movement to stop before adjusting, cleaning or repairing.
- Clean grass and debris from cutting unit, drives, mufflers, and engine to help prevent fires. Clean up oil or fuel spillage.
- Let engine cool before storing and do not store near flame.
- Shut off fuel while storing or transporting. Do not store fuel near flames or drain indoors.
- Park machine on level ground. Set parking brake. Never allow untrained personnel to service machine.
- Use jack stands to support components when required.
- Carefully release pressure from components with stored energy.
- Disconnect the battery or remove spark plug wire before making any repairs. Disconnect the negative terminal first and the positive last. Reconnect the positive first and negative last.
- Use care when checking blades. Wrap the blade(s) or wear gloves, and use caution when servicing them. Only replace blades. Never straighten or weld them.
- Keep hands and feet away from moving parts. If possible, do not make adjustments with the engine running.
- Keep all parts in good working condition and all hardware tightened. Replace all worn or damaged decals.

Hauling

- Use care when loading or unloading the machine into a trailer or truck.
- Use full width ramps for loading machine into trailer or truck.
- Tie the machine down securely using straps, chains, cable, or ropes. Both front and rear straps should be directed down and outward from the machine.

Slope Indicator

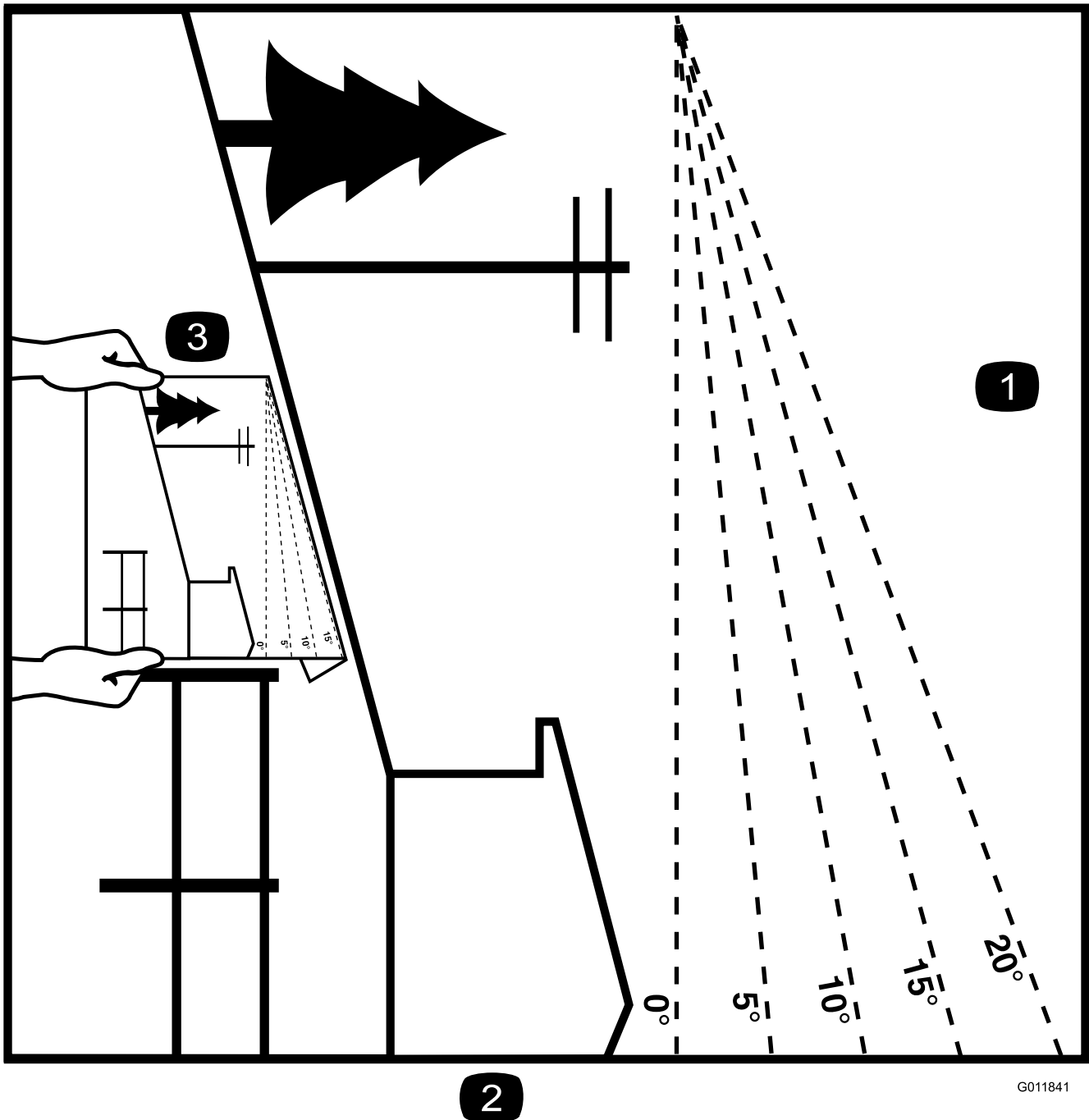

G011841

2

Figure 3

This page may be copied for personal use.

1. The maximum slope you can safely operate the machine on is **15 degrees**. Use the slope chart to determine the degree of slope of hills before operating. **Do not operate this machine on a slope greater than 15 degrees**. Fold along the appropriate line to match the recommended slope.
2. Align this edge with a vertical surface, a tree, building, fence pole, etc.
3. Example of how to compare slope with folded edge.

Safety and Instructional Decals



Safety decals and instructions are easily visible to the operator and are located near any area of potential danger. Replace any decal that is damaged or lost.



1-403005



68-8340



54-9220



98-5954



103-2076



1
58-6520

1. Grease

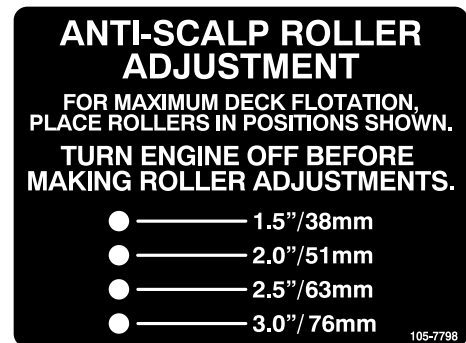

105-7798



66-1340

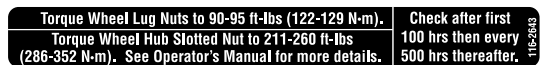

116-2643

WARNING

TO AVOID INJURY OR DEATH FROM ROLLOVER:
Keep roll bar in the raised and locked position and use seat belt.

THERE IS NO ROLL OVER PROTECTION WHEN THE ROLL BAR IS DOWN.
Lower the roll bar only when absolutely necessary.
Do not wear seat belt when the roll bar is down.
Drive slowly and carefully.
Raise the roll bar as soon as clearance permits.
Read and follow slope operation instructions and warnings.

107-2102

107-2102

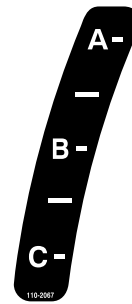

110-2067

**ADJUSTABLE BAFFLE
BAFLE AJUSTABLE**

A -	• Short, light grass • Dry conditions • Maximum dispersion		• Césped corto y ligero • Condiciones secas • Maxima dispersion
B -	• Bagging setting		• Posición para usar con bolsa
C -	• Tall, dense grass • Wet conditions • Maximum ground speed		• Césped alto y denso • Condiciones mojadas • Maxima velocidad

110-2068

110-2068

1. Read the *Operator's Manual*.

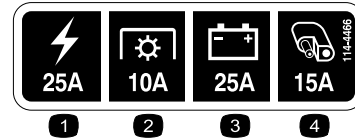

114-4466

1. Main, 25A
2. PTO, 10A
3. Charge, 25A
4. Auxiliary, 15A

MOTION CONTROL

109-7232

1. Fast
2. Slow
3. Neutral
4. Reverse

WARNING

ROTATING BELT DRIVE
Can cause serious injury
Stop engine and wait until all moving parts have stopped before reaching underneath.

116-0205

116-0205

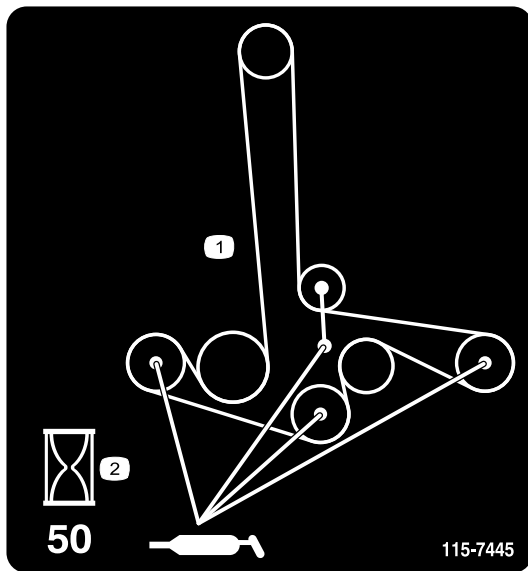

115-7445

1. Grease pulleys and spindles
2. Maintenance interval—50 hours

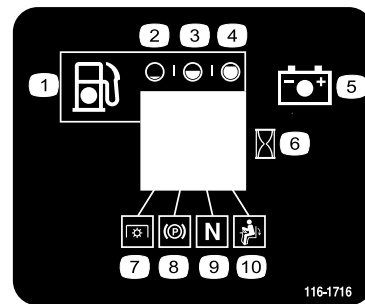

116-1716

- | | |
|------------|------------------------------|
| 1. Fuel | 6. Hour meter |
| 2. Empty | 7. PTO |
| 3. Half | 8. Parking brake |
| 4. Full | 9. Neutral |
| 5. Battery | 10. Operator presence switch |

⚠ WARNING

- Operating on wet grass or steep slopes can cause sliding and loss of control.
- Wheels dropping over edges can cause rollovers.
- Going up or backing down steep slopes or ramps can result in backward rollovers.

To avoid loss of control and possibility of rollover resulting in serious injury or death:

- Do not operate near drop-offs or water.
- Do not operate on slopes or ramps greater than 15°.
- Do not use split ramps; use full width ramps to load a unit for transport.
- Reduce speed and use extreme caution on slopes or ramps.
- Avoid sudden turns and rapid speed changes.

There is no rollover protection when the roll bar is down. Always keep roll bar in the raised and locked position and use seat belt. Read and follow rollover protection instructions and warnings.

GREATER THAN 15°

LESS THAN 15°

116-3303

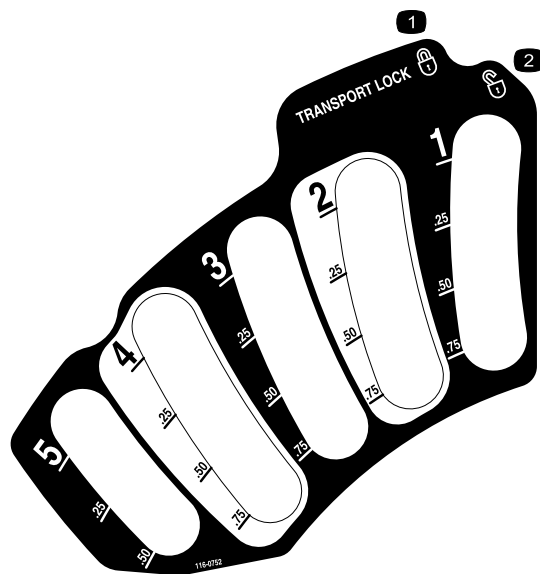

116-0752

1. Latch
2. Unlatch



116-1654

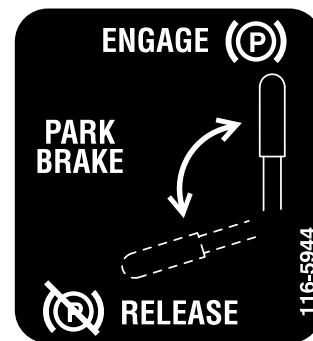

116-5944

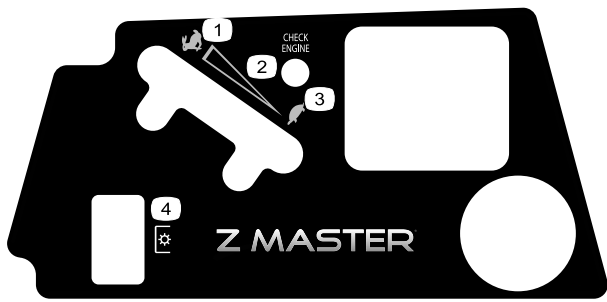

121-7586

- | | |
|---------------------------|-------------------------|
| 1. Fast | 3. Slow |
| 2. Variable speed control | 4. Power take-off (PTO) |



Battery Symbols

Some or all of these symbols are on your battery

- | | |
|--|--|
| 1. Explosion hazard | 6. Keep bystanders a safe distance from the battery. |
| 2. No fire, open flame, or smoking. | 7. Wear eye protection; explosive gases can cause blindness and other injuries |
| 3. Caustic liquid/chemical burn hazard | 8. Battery acid can cause blindness or severe burns. |
| 4. Wear eye protection | 9. Flush eyes immediately with water and get medical help fast. |
| 5. Read the <i>Operator's Manual</i> . | 10. Contains lead; do not discard. |

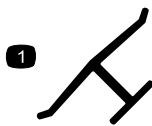

Manufacturer's Mark

1. Indicates the blade is identified as a part from the original machine manufacturer.



116-0157

1. Only use recommended hydro oil

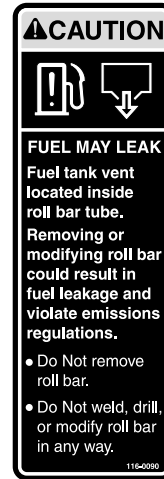

116-0090

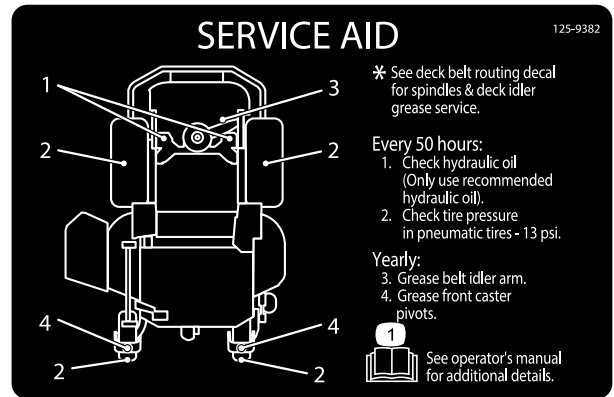

125-9382

1. Read the *Operator's Manual* for more information on servicing the machine.



109-7069

Product Overview

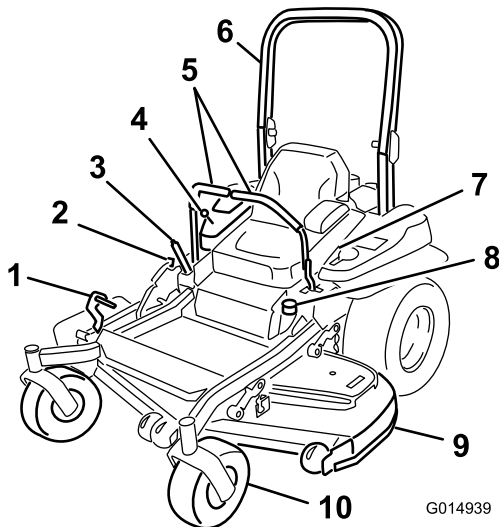

Figure 4

- | | |
|----------------------------------|------------------|
| 1. Height-of-cut deck lift pedal | 6. Roll bar |
| 2. Transport lock | 7. Seat belt |
| 3. Parking brake lever | 8. Fuel cap |
| 4. Controls | 9. Mower deck |
| 5. Motion control levers | 10. Caster wheel |

Controls

Become familiar with all the controls before you start the engine and operate the machine (Figure 4 and Figure 5).

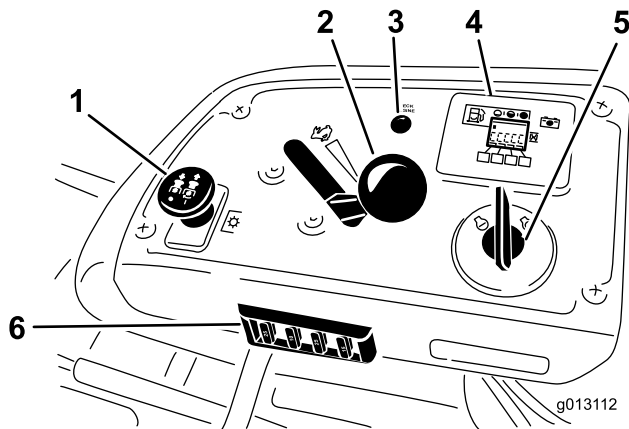

Figure 5

- | | |
|--------------------------------------|---|
| 1. PTO Switch | 4. Hour meter/Safety interlock display/Fuel gauge |
| 2. Throttle control | 5. Ignition switch |
| 3. Malfunction indicator light (MIL) | 6. Fuses |

Hour Meter

The hour meter records the number of hours the engine has operated. It operates when the engine is running. Use these times for scheduling regular maintenance (Figure 5).

Fuel Gauge

The fuel gauge is located with the hour meter and the bars light up when the ignition switch is on (Figure 6).

The indicator light appears when the fuel level is low (approximately one gallon remaining in the fuel tank).

Safety Interlock Indicators

There are symbols on the hour meter and the indicate with a black triangle that the interlock component is in the correct position (Figure 5).

Battery Indicator Light

If the ignition key is turned to the **On** position for a few seconds, the battery voltage will be displayed in the area where the hours are normally displayed.

The battery light turns on when the ignition is turned on and when the charge is below the correct operating level (Figure 6).

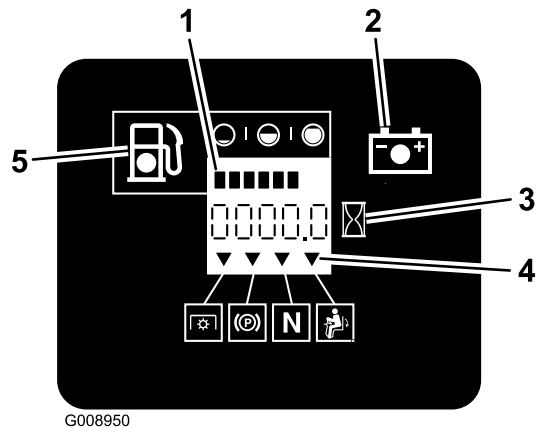

Figure 6

- | | |
|----------------------|-----------------------------|
| 1. Fuel gauge (bars) | 4. Safety interlock symbols |
| 2. Battery light | 5. Low fuel indicator light |
| 3. Hour meter | |

Throttle Control

The throttle control is variable between the **Fast** and **Slow** positions.

Blade Control Switch (PTO)

The blade control switch (PTO) is used to engage the electric clutch and drive the mower blades. Pull the switch up to engage the blades and release. To disengage the blades, push the blade control switch (PTO) down or move a motion control lever into the neutral lock position.

Ignition Switch

This switch is used to start the mower engine and has 3 positions: **Start**, **Run**, and **Off**.

Motion Control Levers

The motion control levers are used to drive the machine forward, reverse, and turn either direction.

Neutral Lock Position

The neutral lock position is used with the safety interlock system to engage and to determine neutral position.

Fuel Shut-off Valve

Close the fuel shut-off valve (under the seat) when transporting or storing the mower.

Electronic Control Unit Malfunction Indicator Light

The electronic control unit (ECU) continuously monitors the operation of the EFI system.

If a problem or fault within the system is detected, the malfunction indicator light (MIL) is illuminated.

The MIL is the red light located in the right console panel.

Once the MIL illuminates, initial trouble shooting checks should be made. Refer to the MIL section under Troubleshooting.

If these checks do not correct the problem, further diagnosis and servicing by an Authorized Service Dealer is necessary.

Attachments/Accessories

A selection of Toro approved attachments and accessories is available for use with the machine to enhance and expand its capabilities. Contact your Authorized Service Dealer or Distributor or go to www.Toro.com for a list of all approved attachments and accessories.

Specifications

Note: Specifications and design are subject to change without notice.

Width:

	60 inch Deck
Without Deck	134.6 cm (53.0 inches)
Deflector Up	156.8 cm (61.7 inches)
Deflector Down	192.2 cm (75.7 inches)

Length:

	60 inch Deck
Roll Bar - Up	211.1 cm (83.1 inches)
Roll Bar - Down	215.4 cm (84.8 inches)

Height:

Roll Bar - Up	Roll Bar - Down
179.1 cm (70.5 inches)	118.9 cm (46.8 inches)

Weight:

Model	Weight
74958	532 kg (1172 lbs)

Operation

Note: Determine the left and right sides of the machine from the normal operating position.

Adding Fuel

- For best results, use only clean, fresh (less than 30 days old), unleaded gasoline with an octane rating of 87 or higher ((R+M)/2 rating method).
- **Ethanol:** Gasoline with up to 10% ethanol (gasohol) or 15% MTBE (methyl tertiary butyl ether) by volume is acceptable. Ethanol and MTBE are not the same. Gasoline with 15% ethanol (E15) by volume is not approved for use. **Never use gasoline that contains more than 10% ethanol by volume**, such as E15 (contains 15% ethanol), E20 (contains 20% ethanol), or E85 (contains up to 85% ethanol). Using unapproved gasoline may cause performance problems and/or engine damage which may not be covered under warranty.
- **Do not** use gasoline containing methanol.
- **Do not** store fuel either in the fuel tank or fuel containers over the winter unless a fuel stabilizer is used.
- **Do not** add oil to gasoline.

▲ DANGER

In certain conditions, gasoline is extremely flammable and highly explosive. A fire or explosion from gasoline can burn you and others and can damage property.

- Fill the fuel tank outdoors, in an open area, when the engine is cold. Wipe up any gasoline that spills.
- Never fill the fuel tank inside an enclosed trailer.
- Do not fill the fuel tank completely full. Add gasoline to the fuel tank until the level is 6 to 13 mm (1/4 to 1/2 inch) below the bottom of the filler neck. This empty space in the tank allows gasoline to expand.
- Never smoke when handling gasoline, and stay away from an open flame or where gasoline fumes may be ignited by a spark.
- Store gasoline in an approved container and keep it out of the reach of children. Never buy more than a 30-day supply of gasoline.
- Do not operate without entire exhaust system in place and in proper working condition.

▲ DANGER

In certain conditions during fueling, static electricity can be released causing a spark which can ignite the gasoline vapors. A fire or explosion from gasoline can burn you and others and can damage property.

- Always place gasoline containers on the ground away from your vehicle before filling.
- Do not fill gasoline containers inside a vehicle or on a truck or trailer bed because interior carpets or plastic truck bed liners may insulate the container and slow the loss of any static charge.
- When practical, remove gas-powered equipment from the truck or trailer and refuel the equipment with its wheels on the ground.
- If this is not possible, then refuel such equipment on a truck or trailer from a portable container, rather than from a gasoline dispenser nozzle.
- If a gasoline dispenser nozzle must be used, keep the nozzle in contact with the rim of the fuel tank or container opening at all times until fueling is complete.

▲ WARNING

Gasoline is harmful or fatal if swallowed. Long-term exposure to vapors can cause serious injury and illness.

- Avoid prolonged breathing of vapors.
- Keep face away from nozzle and gas tank or conditioner bottle opening.
- Avoid contact with skin; wash off spillage with soap and water.

Using Stabilizer/Conditioner

Use a fuel stabilizer/conditioner in the machine to provide the following benefits:

- Keeps gasoline fresh during storage of 90 days or less. For longer storage it is recommended that the fuel tank be drained.
- Cleans the engine while it runs
- Eliminates gum-like varnish buildup in the fuel system, which causes hard starting

Important: Do not use fuel additives containing methanol or ethanol.

Add the correct amount of gas stabilizer/conditioner to the gas.

Note: A fuel stabilizer/conditioner is most effective when mixed with fresh gasoline. To minimize the chance

of varnish deposits in the fuel system, use fuel stabilizer at all times.

Filling the Fuel Tank

1. Shut the engine off and set the parking brake.
2. Clean around the fuel tank cap and remove the cap. Add unleaded regular gasoline to the fuel tank, until the level is 6 to 13 mm (1/4 to 1/2 inch) below the bottom of the filler neck. This space in the tank allows the gasoline to expand. Do not fill the fuel tank completely full.
3. Install the fuel tank cap securely. Wipe up any gasoline that may have spilled.

Checking the Engine Oil Level

Before you start the engine and use the machine, check the oil level in the engine crankcase; refer to Checking the Engine Oil Level (page 31).

Breaking In a New Machine

New engines take time to develop full power. Mower decks and drive systems have higher friction when new, placing additional load on the engine. Allow 40 to 50 hours of break-in time for new machines to develop full power and best performance.

Using the Rollover Protection System (ROPS)

⚠ WARNING

To avoid injury or death from rollover: keep the roll bar in the fully raised locked position and use the seat belt.

Ensure that the seat is secured to the machine.

⚠ WARNING

There is no rollover protection when the roll bar is in the down position.

- Lower the roll bar only when absolutely necessary.
- Do not wear the seat belt when the roll bar is in the down position.
- Drive slowly and carefully.
- Raise the roll bar as soon as clearance permits.
- Check carefully for overhead clearances (i.e. branches, doorways, electrical wires) before driving under any objects and do not contact them.

Important: Lower the roll bar only when absolutely necessary.

Important: Ensure that the seat is secured to the machine.

1. To lower the roll bar, apply forward pressure to the upper part of the roll bar.
2. Pull both knobs out and rotate them 90° so that they are not engaged (Figure 7).
3. Lower the roll bar to the down position (Figure 7).

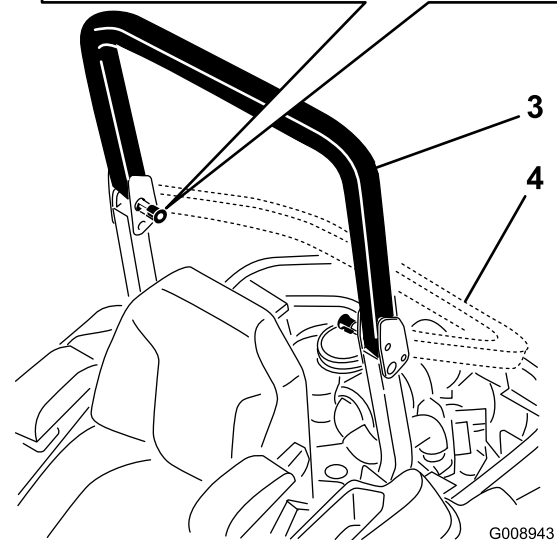
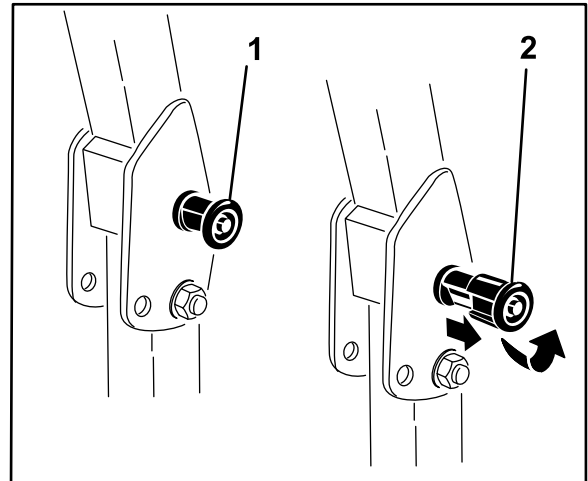

Figure 7

- | | |
|---|-------------------------------------|
| 1. ROPS knob | 3. Roll bar in the upright position |
| 2. Pull ROPS knob out and rotate 90 degrees | 4. Roll bar in the folded position |

4. To raise the roll bar, raise the roll bar to the operate position, rotate the knobs so they move partially into the grooves (Figure 7).
5. Raise the roll bar to the full upright position while pushing on the upper roll bar and the pins will snap into position when the holes align with the pins (Figure 7). Push on the roll bar and ensure that both pins are engaged.

Important: Always use the seat belt with the roll bar in the fully raised position.

Think Safety First

Please read all safety instructions and symbols in the safety section. Knowing this information could help you or bystanders avoid injury.

⚠ DANGER

Operating on wet grass or steep slopes can cause sliding and loss of control.

Wheels dropping over edges can cause rollovers, which may result in serious injury, death or drowning.

There is no rollover protection when the roll bar is down.

Always keep the roll bar in the fully raised and locked position and use the seat belt.

Read and follow the rollover protection instructions and warnings.

To avoid loss of control and possibility of rollover:

- Do not operate near drop-offs or near water.
- Do not operate on slopes greater than 15 degrees.
- Reduce speed and use extreme caution on slopes.
- Avoid sudden turns or rapid speed changes.

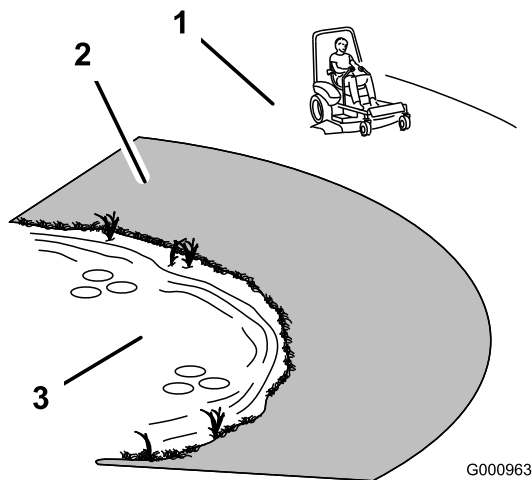

Figure 8

G000963

1. Safe Zone-use the Z Master here on slopes less than 15 degrees or flat areas.
2. Danger Zone- use a walk behind mower and/or a hand trimmer on slopes greater than 15 degrees, near drop-offs and water.
3. Water

⚠ CAUTION

This machine produces sound levels in excess of 85 dBA at the operators ear and can cause hearing loss through extended periods of exposure.

Wear hearing protection when operating this machine.

The use of protective equipment for eyes, ears, feet, and head is recommended.

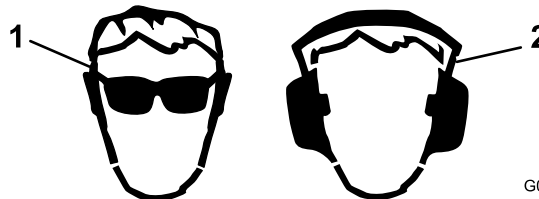

G009027

Figure 9

1. Wear safety glasses
2. Wear hearing protection

Operating the Parking Brake

Always set the parking brake when you stop the machine or leave it unattended.

Setting the Parking Brake

⚠ WARNING

Parking brake may not hold machine parked on a slope and could cause personal injury or property damage.

Do not park on slopes unless wheels are chocked or blocked

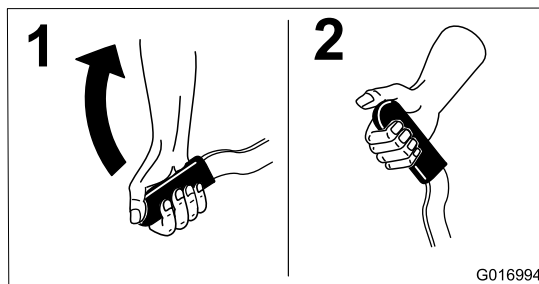

G016994

Figure 10

Releasing the Parking Brake

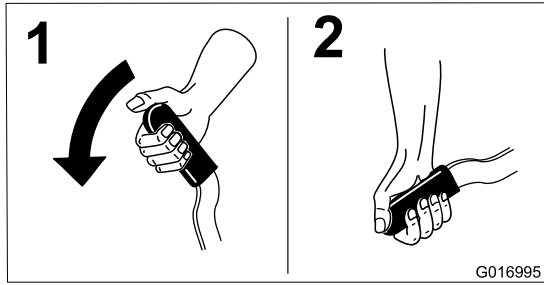

Figure 11

Operating the Mower Blade Control Switch (PTO)

The blade control switch (PTO) starts and stops the mower blades and any powered attachments.

Engaging the Blade Control Switch (PTO)

Note: Engaging the blade control switch (PTO) with the throttle position at half or less will cause excessive wear to the drive belts.

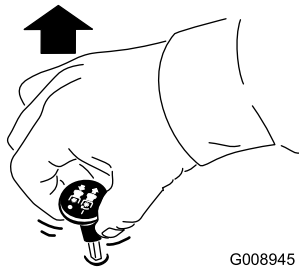

Figure 12

Disengaging the Blade Control Switch (PTO)

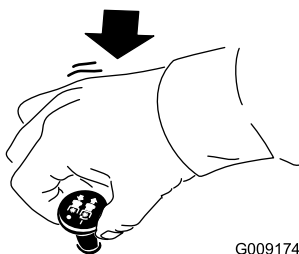

Figure 13

Operating the Throttle

The throttle control can be moved between the **Fast** and **Slow** positions (Figure 14).

Always use the fast position when turning on the mower deck with the blade control switch (PTO).

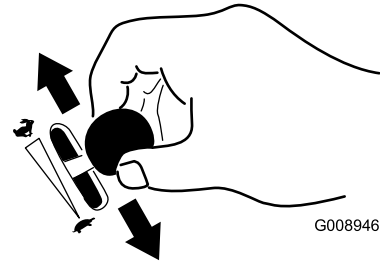

Figure 14

Operating the Ignition Switch

1. Turn the ignition key to the Start position (Figure 15). When the engine starts, release the key.

Important: Do not engage starter for more than 5 seconds at a time. If the engine fails to start allow a 15 second cool-down period between attempts. Failure to follow these instructions can burn out the starter motor.

Note: Additional starting cycles may be required when starting the engine for the first time after the fuel system has been without fuel completely.

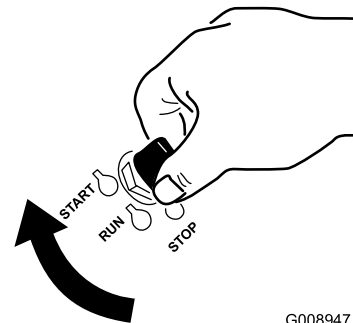

Figure 15

2. Turn the ignition key to stop to stop the engine.

Using the Fuel Shut-Off Valve

The fuel shut-off valve is located under the seat. Move the seat forward to access it.

Close the fuel shut-off valve for transport, maintenance, and storage.

Ensure the fuel shut-off valve is open when starting the engine.

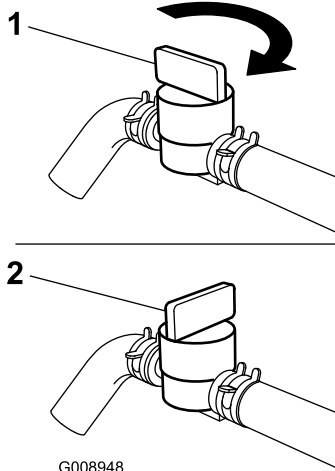

Figure 16

1. On

2. Off

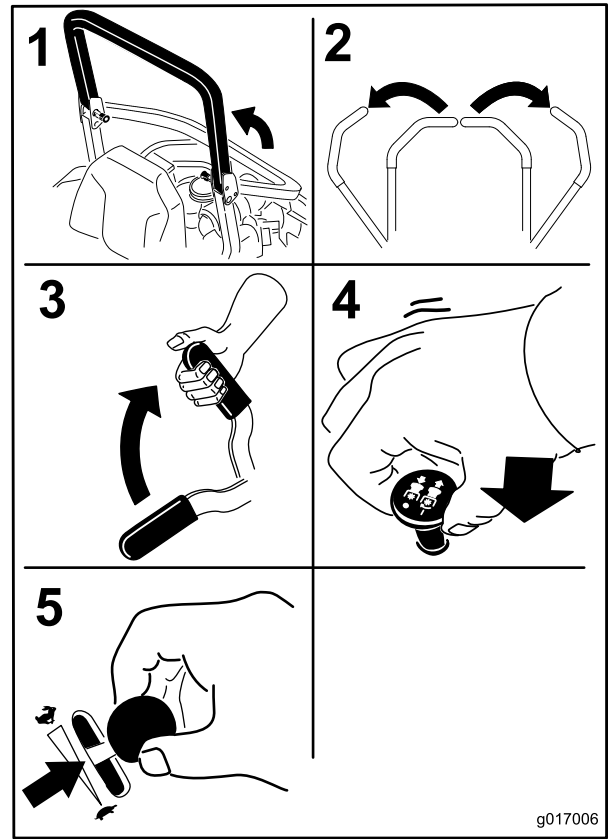

Figure 17

Starting and Stopping the Engine

Starting the Engine

1. Raise the ROPS up and lock into place, sit on the seat and fasten the seat belt.
2. Move the motion controls to neutral locked position.
3. Set the parking brake; refer to Setting the Parking Brake (page 15).
4. Move the blade control switch (PTO) to the off position (Figure 17).
5. Move the throttle lever midway between the slow and fast positions.

6. Turn the ignition key to the Start position (Figure 15). When the engine starts, release the key.

Important: Do not engage starter for more than 5 seconds at a time. If the engine fails to start allow a 15 second cool-down period between attempts. Failure to follow these instructions can burn out the starter motor.

Note: Additional starting cycles may be required when starting the engine for the first time after the fuel system has been without fuel completely.

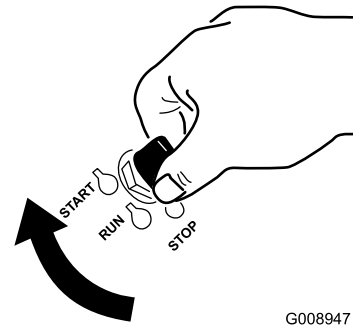

Figure 18

1. Off
2. Run

3. Start

Stopping the Engine

⚠ CAUTION

Children or bystanders may be injured if they move or attempt to operate the machine while it is unattended.

Always remove the ignition key and set the parking brake when leaving the machine unattended, even if just for a few minutes.

Let the engine idle at slow throttle (turtle) for 60 seconds before turning the ignition switch off.

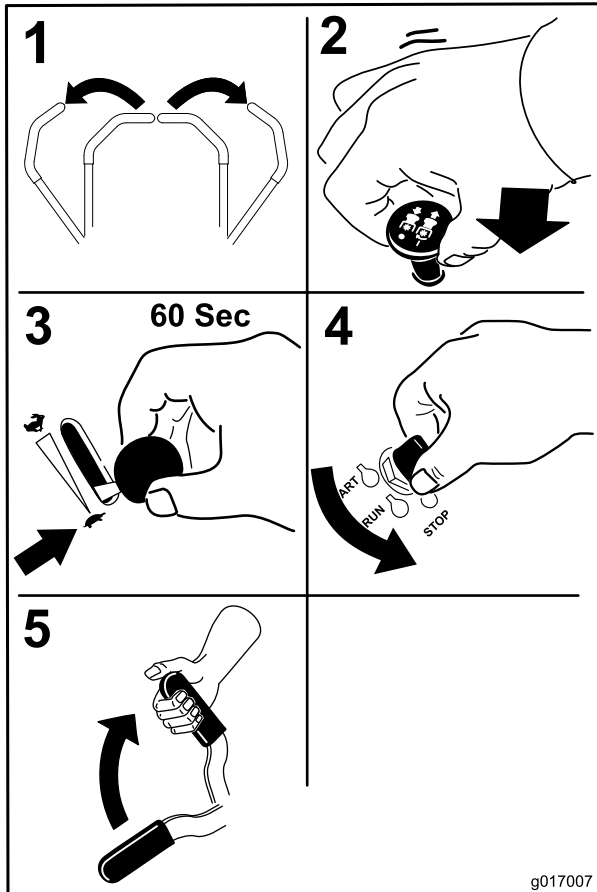

Figure 19

Important: Make sure that the fuel shut off valve is closed before transporting or storing the machine, as fuel leakage may occur. Set the parking brake before transporting. Make sure to remove the key as the fuel pump may run and cause the battery to lose charge.

The Safety Interlock System

⚠ CAUTION

If safety interlock switches are disconnected or damaged the machine could operate unexpectedly causing personal injury.

- Do not tamper with the interlock switches.
- Check the operation of the interlock switches daily and replace any damaged switches before operating the machine.

Understanding the Safety Interlock System

The safety interlock system is designed to prevent the engine from starting unless:

- The parking brake is engaged.
- The blade control switch (PTO) is disengaged.
- The motion control levers are in the neutral locked position

The safety interlock system also is designed to stop the engine when the traction controls are moved from the locked position with the parking brake engaged or if you rise from the seat when the PTO is engaged.

The hour meter has symbols to notify the user when the interlock component is in the correct position. When the component is in the correct position, a triangle will light up in the corresponding square.

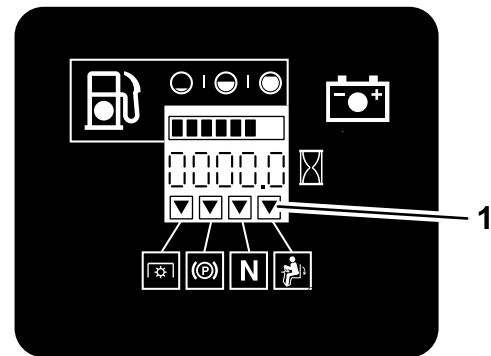

G009181

Figure 20

1. Triangles light up when the interlock components are in the correct position

Testing the Safety Interlock System

Service Interval: Before each use or daily

Test the safety interlock system before you use the machine each time. If the safety system does not operate as described below, have an Authorized Service Dealer repair the safety system immediately.

1. Sitting on the seat, engage the parking brake and move the blade control switch (PTO) to on. Try starting the engine; the engine should not crank.
2. Sitting on the seat, engage the parking brake and move the blade control switch (PTO) to off. Move either motion control lever (out of neutral locked position). Try starting the engine; the engine should not crank. Repeat for other control lever.
3. Sitting on the seat, engage the parking brake, move the blade control switch (PTO) to off and move the motion control levers to neutral lock position. Now start the engine. While the engine is running, release the parking brake, engage the blade control switch (PTO) and rise slightly from the seat; the engine should stop.
4. Sitting on the seat, engage the parking brake, move the blade control switch (PTO) to off and move the motion control levers to neutral lock position. Now start the engine. While the engine is running, center either motion control and move (forward or reverse); the engine should stop. Repeat for other motion control.
5. Sitting on the seat, disengage the parking brake, move the blade control switch (PTO) to off and move the motion control levers to neutral lock position. Try starting the engine; the engine should not crank.

Using the Motion Control Levers

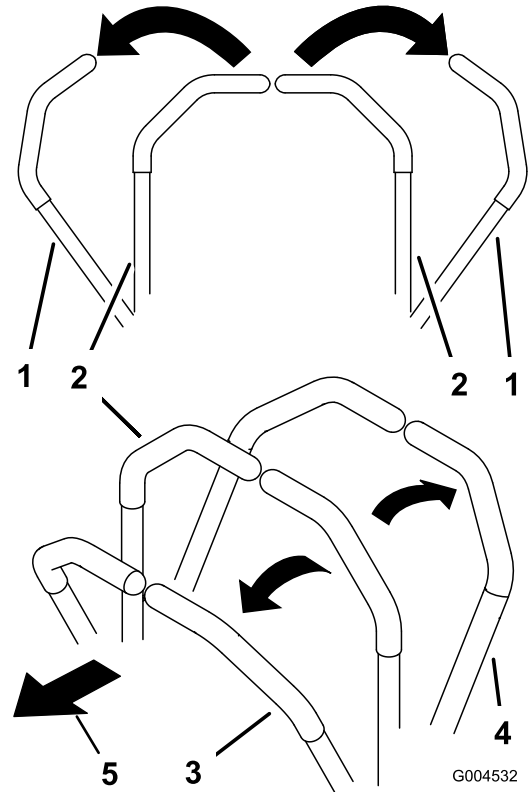

Figure 21

- | | |
|---|---------------------|
| 1. Motion control lever-neutral lock position | 4. Backward |
| 2. Center, unlocked position | 5. Front of machine |
| 3. Forward | |

Driving Forward or Backward

The throttle control regulates the engine speed as measured in rpm (revolutions per minute). Place the throttle control in the fast position for best performance. Always operate in the full throttle position when mowing.

CAUTION

Machine can spin very rapidly. Operator may lose control of machine and cause personal injury or damage to machine.

- Use caution when making turns.
- Slow the machine down before making sharp turns.

Driving Forward

Note: The engine will kill if the traction control levers are moved with the parking brake engaged.

To stop, pull the motion control levers to the neutral position.

1. Release the parking brake; refer to Releasing the Parking Brake (page 16).
2. Move the levers to the center, unlocked position.
3. To go forward, slowly push the motion control levers forward (Figure 22).

Stopping the Machine

To stop the machine, move the traction control levers to neutral and move to locked position, disengage the power take off (blade control switch (PTO)), and turn the ignition key to the off position.

Set the parking brake when you leave the machine; refer to Setting the Parking Brake (page 15). Remove the key from the ignition switch.

⚠ CAUTION

Children or bystanders may be injured if they move or attempt to operate the machine while it is unattended.

Always remove the ignition key and set the parking brake when leaving the machine unattended, even if just for a few minutes.

Adjusting the Height of Cut

Using the Transport Lock

The transport lock has 2 positions and is used with the deck lift pedal. There is a lock position and a unlock position for the transport position. The transport lock is used with the deck lift pedal. Refer to Figure 24.

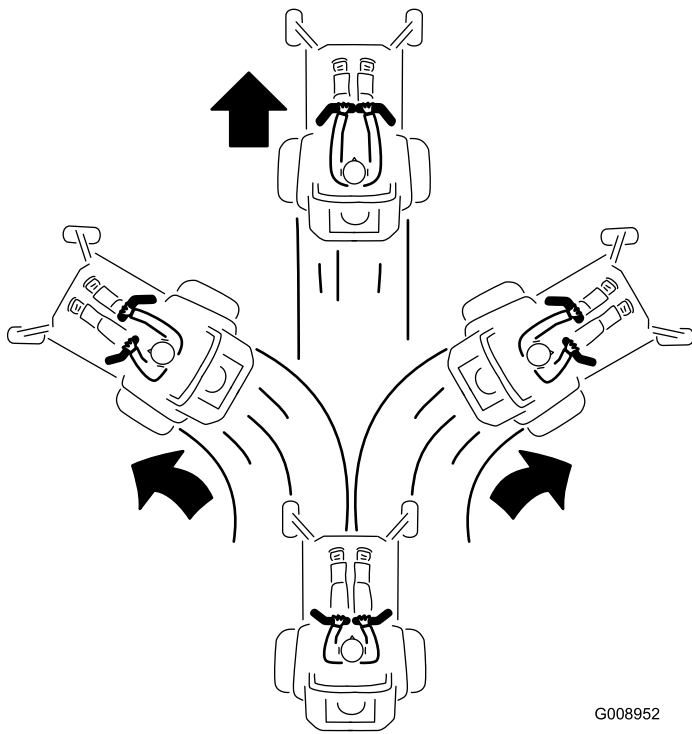

Figure 22

G008952

Driving Backward

1. Move the levers to the center, unlocked position.
2. To go backward, slowly pull the motion control levers rearward (Figure 23).

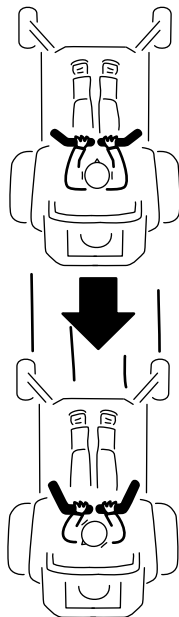

Figure 23

G008953

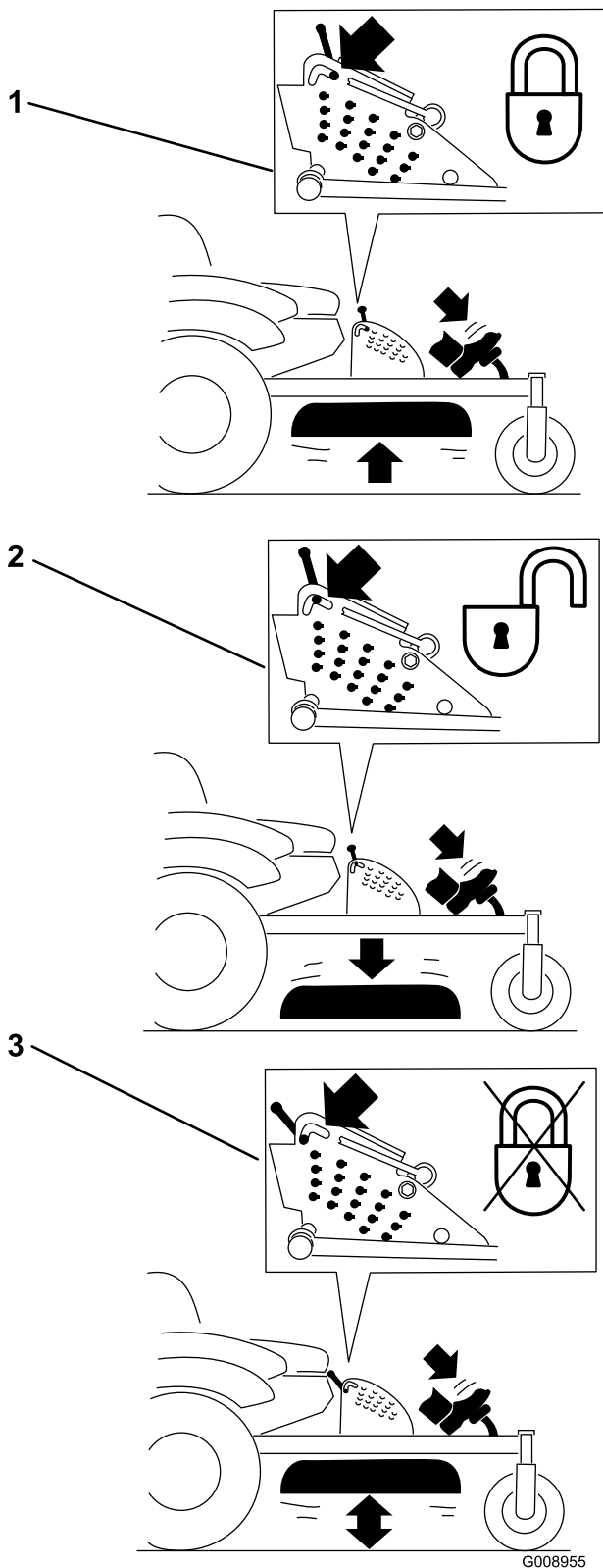

Figure 24

Transport Lock Positions

1. Transport lock
2. Lock position—mower deck will lock into transport position
3. Unlock position—does not lock the mower deck into transport position

Adjusting the Height-of-Cut Pin

The height-of-cut is adjusted from 25 to 140 mm (1 to 5-1/2 inches) in 6 mm (1/4 inch) increments by relocating the clevis pin into different hole locations.

1. Move the transport lock to the lock position.
2. Push on the deck lift pedal with your foot and raise the mower deck to the transport position (also the 140 mm (5-1/2 inch) cutting height position) (Figure 25).
3. To adjust, rotate the pin 90 degrees and remove the pin from the height-of-cut bracket (Figure 25).
4. Select a hole in the height-of-cut bracket corresponding to the height-of-cut desired and, insert the pin (Figure 25).
5. Push on the deck lift, pull back on the transport lock, and slowly lower the mower deck.

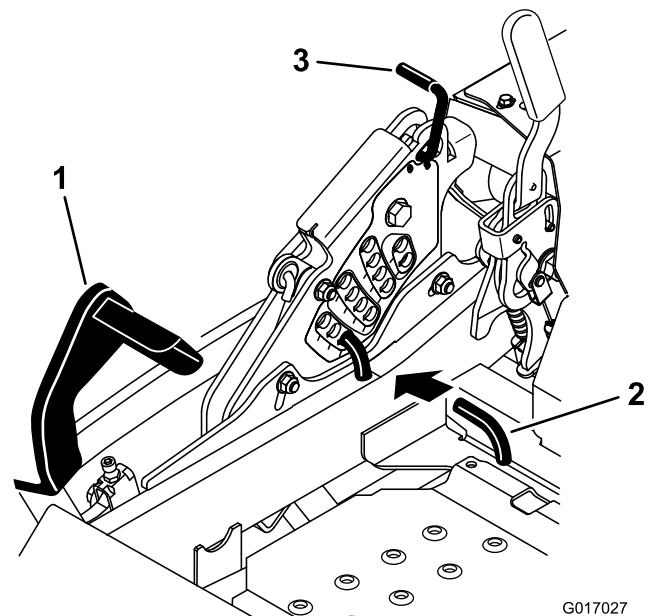

Figure 25

1. Deck lift pedal
2. Cut of height pin
3. Transport lock

Adjusting the Anti-scalp Rollers

Whenever you change the height-of-cut, it is recommended to adjust the height of the anti-scalp rollers.

1. Disengage the blade-control switch (PTO), move the motion-control levers to the neutral-locked position, and set the parking brake.
2. Stop the engine, remove the key, and wait for all moving parts to stop before leaving the operating position.
3. Adjust the anti-scalp rollers as shown in Figure 26, Figure 27, and Figure 28.

ANTI-SCALP ROLLER ADJUSTMENT
 FOR MAXIMUM DECK FLOTATION,
 PLACE ROLLERS IN POSITIONS SHOWN.
 TURN ENGINE OFF BEFORE
 MAKING ROLLER ADJUSTMENTS.

- 1.5"/38mm
- 2.0"/51mm
- 2.5"/63mm
- 3.0"/76mm

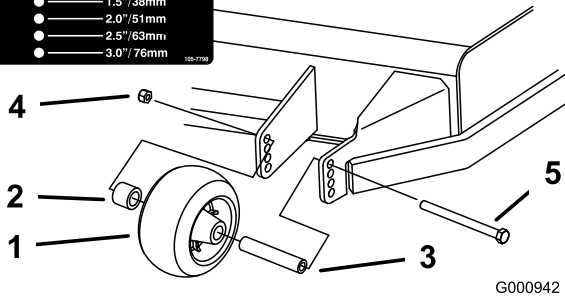

Figure 26

- 1. Anti-scalp roller
- 2. Spacer
- 3. Bushing
- 4. Flange nut
- 5. Bolt

ANTI-SCALP ROLLER ADJUSTMENT
 FOR MAXIMUM DECK FLOTATION,
 PLACE ROLLERS IN POSITIONS SHOWN.
 TURN ENGINE OFF BEFORE
 MAKING ROLLER ADJUSTMENTS.

- 1.5"/38mm
- 2.0"/51mm
- 2.5"/63mm
- 3.0"/76mm

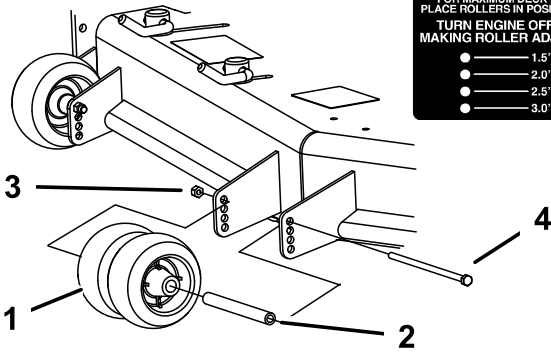

Figure 27

- 1. Anti-scalp roller
- 2. Bushing
- 3. Flange nut
- 4. Bolt

ANTI-SCALP ROLLER ADJUSTMENT
 FOR MAXIMUM DECK FLOTATION,
 PLACE ROLLERS IN POSITIONS SHOWN.
 TURN ENGINE OFF BEFORE
 MAKING ROLLER ADJUSTMENTS.

- 1.5"/38mm
- 2.0"/51mm
- 2.5"/63mm
- 3.0"/76mm

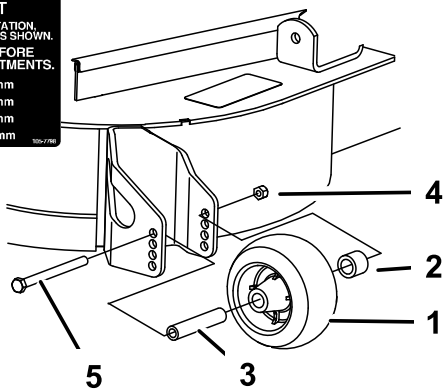

Figure 28

- 1. Anti-scalp roller
- 2. Spacer
- 3. Bushing
- 4. Flange nut
- 5. Bolt

Adjusting the Flow Baffle Cam Locks

This procedure is applicable only to machines with the flow baffle locks. Certain models will have nuts and bolts in-place of the flow baffle locks and can be adjusted the same.

The mower discharge flow can be adjusted for different types of mowing conditions. Position the cam locks and baffle to give the best quality of cut.

1. Disengage the blade control switch (PTO), move the motion control levers to the neutral locked position, and set the parking brake.
2. Stop the engine, remove the key, and wait for all moving parts to stop before leaving the operating position.
3. To adjust the cam locks, swing the lever up to loosen the cam lock (Figure 29).
4. Adjust the baffle and cam locks in the slots to the desired discharge flow.
5. Swing the lever back over to tighten the baffle and cam locks (Figure 29).
6. If the cam locks do not lock the baffle into place or it is too tight, loosen the lever and then rotate the cam lock. Adjust the cam lock until the desired locking pressure is achieved.

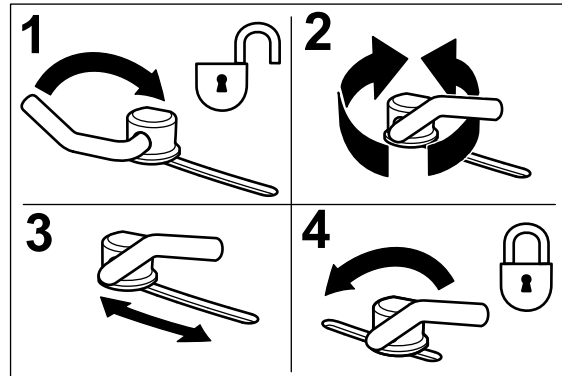

Figure 29

- 1. Unlock lever
- 2. Rotate the cam lock to increase or decrease locking pressure
- 3. Position the baffle
- 4. Lock lever

Positioning the Flow Baffle

The following figures are only recommendations for use. Adjustments will vary by grass type, moisture content, and height of grass.

Note: If the engine power draws down and the mower ground speed is the same, open up the baffle.

Position A

This is the full rear position. The suggested use for this position is as follows.

- Use for short, light grass mowing conditions.
- Use in dry conditions.
- For smaller grass clippings.
- Propels grass clippings farther away from the mower.

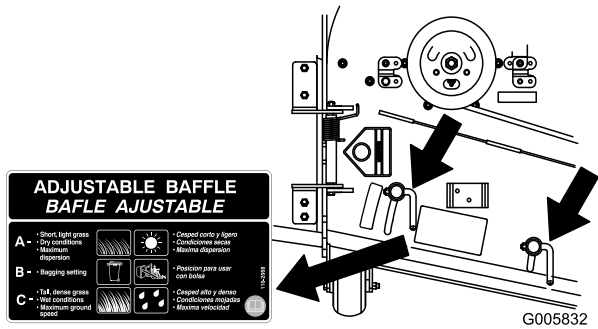

Figure 30

Position B

Use this position when bagging. Always align it with the blower opening.

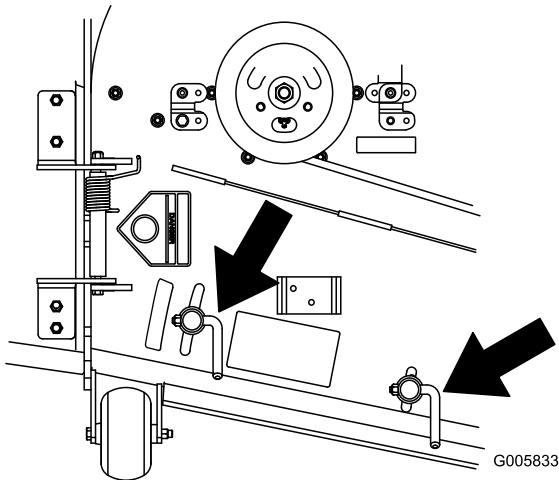

Figure 31

Position C

This is the full open position. The suggested use for this position is as follows.

- Use in tall, dense grass mowing conditions.
- Use in wet conditions.
- Lowers the engine power consumption.
- Allows increased ground speed in heavy conditions.
- This position is similar to the benefits of the Toro SFS mower.

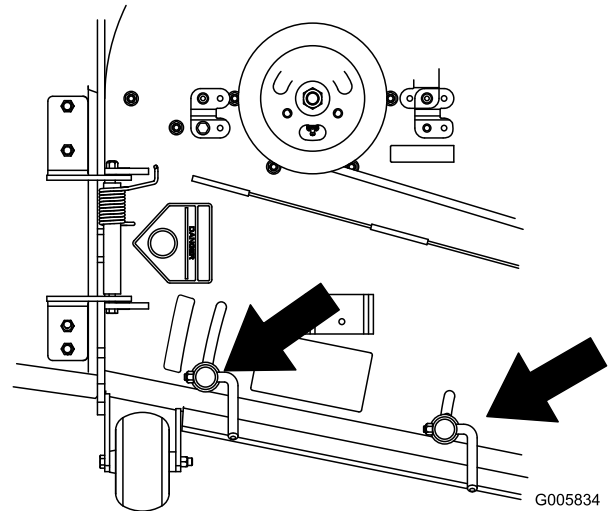

Figure 32

Positioning the Seat

The seat can move forward and backward. Position the seat where you have the best control of the machine and are most comfortable.

To adjust, move the lever sideways to unlock seat (Figure 33).

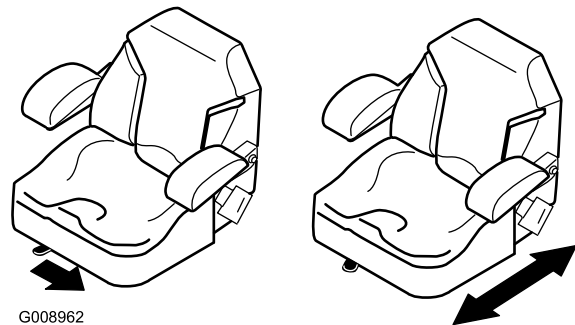

Figure 33

Using the Drive Wheel Release Valves

⚠ WARNING

Hands may become entangled in the rotating drive components below the engine deck, which could result in serious injury.

Stop the engine, remove the key, and allow all moving parts to stop before accessing the drive wheel release valves.

⚠ WARNING

The engine and hydraulic drive units can become very hot. Touching a hot engine or hydraulic drive units can cause severe burns.

Allow the engine and hydraulic drive units to cool completely before accessing the drive wheel release valves.

The drive wheel release valves are located in the back of each hydraulic drive unit, under the seat.

Note: Make sure the release valves are in the fully horizontal position when operating the machine or severe damage to the hydraulic system can occur.

1. Disengage the PTO (blade control switch) and turn the ignition key to off. Move the levers to neutral locked position and apply parking brake. Remove the key.
2. Rotate the release valve levers vertically to push the machine. This allows hydraulic oil to by-pass the pump enabling the wheels to turn (Figure 34).
3. Disengage parking brake before pushing.

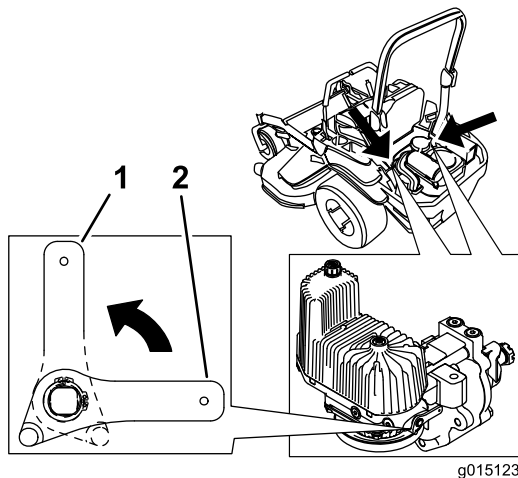

Figure 34

1. Vertical to push the machine
2. Horizontal to run the machine

4. Rotate the release valve levers horizontally to run the machine (Figure 34).

Using the Side Discharge

The mower has a hinged grass deflector that disperses clippings to the side and down toward the turf.

⚠ DANGER

Without a grass deflector, discharge cover, or complete grass catcher assembly mounted in place, you and others are exposed to blade contact and thrown debris. Contact with rotating mower blade(s) and thrown debris will cause injury or death.

- Never remove the grass deflector from the mower because the grass deflector routes material down toward the turf. If the grass deflector is ever damaged, replace it immediately.
- Never put your hands or feet under the mower.
- Never try to clear the discharge area or mower blades unless you move the power take off (blade control switch (PTO) to the off position, rotate the ignition key to off and remove the key.
- Make sure the grass deflector is in the down position.

Loading Machines

Use extreme caution when loading units on trailers or trucks. One full width ramp that is wide enough to extend beyond the rear tires is recommended instead of individual ramps for each side of the unit (Figure 35). The lower rear section of the machine frame extends back between the rear wheels and serves as a stop for tipping backward. Having a full width ramp provides a surface for the frame members to contact if the unit starts to tip backward. If it is not possible to use one full width ramp, use enough individual ramps to simulate a full width continuous ramp.

The ramp should be long enough so that the angles do not exceed 15 degrees (Figure 35). A steeper angle may cause mower components to get caught as the unit moves from ramp to trailer or truck. Steeper angles may also cause the unit to tip backward. If loading on or near a slope, position the trailer or truck so it is on the down side of the slope and the ramp extends up the slope. This will minimize the ramp angle. The trailer or truck should be as level as possible.

Important: Do Not attempt to turn the unit while on the ramp; you may lose control and drive off the side.

Avoid sudden acceleration when driving up a ramp and sudden deceleration when backing down a ramp. Both maneuvers can cause the unit to tip backward.

⚠ WARNING

Loading a unit onto a trailer or truck increases the possibility of backward tip-over and could cause serious injury or death.

- Use extreme caution when operating a unit on a ramp.
- Ensure the ROPS is in the up position while using the seat belt when loading the machine. Ensure the ROPS will clear the top of an enclosed trailer.
- Use only a single, full width ramp; Do Not use individual ramps for each side of the unit.
- If individual ramps must be used, use enough ramps to create an unbroken ramp surface wider than the unit.
- Do not exceed a 15 degree angle between ramp and ground or between ramp and trailer or truck.
- Avoid sudden acceleration while driving unit up a ramp to avoid tipping backward.
- Avoid sudden deceleration while backing unit down a ramp to avoid tipping backward.

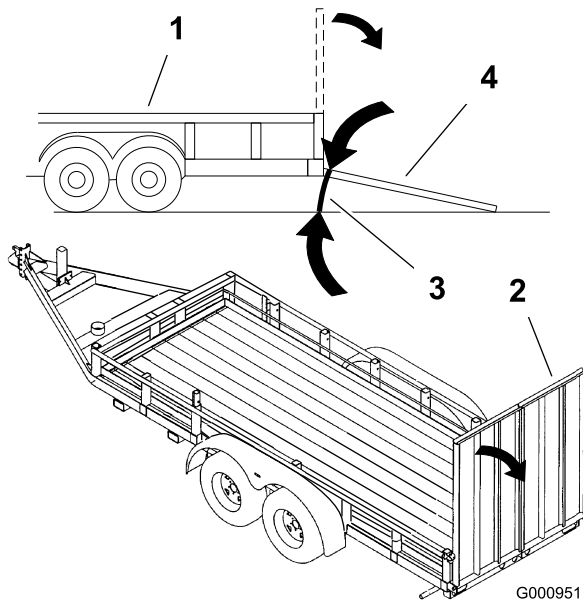

Figure 35

- | | |
|--------------------|--------------------------------|
| 1. Trailer | 3. Not greater than 15 degrees |
| 2. Full width ramp | 4. Full width ramp—side view |

Transporting Machines

Use a heavy-duty trailer or truck to transport the machine. Ensure that the trailer or truck has all necessary brakes, lighting, and marking as required by law. Please carefully read all the safety instructions. Knowing this information could help you, your family, pets or bystanders avoid injury.

⚠ WARNING

Driving on the street or roadway without turn signals, lights, reflective markings, or a slow moving vehicle emblem is dangerous and can lead to accidents causing personal injury.

Do not drive machine on a public street or roadway.

To transport the machine:

1. If using a trailer, connect it to the towing vehicle and connect the safety chains.
2. If applicable, connect the trailer brakes.
3. Load the machine onto the trailer or truck.
4. Stop the engine, remove the key, set the brake, and close the fuel valve.
5. Use the metal tie down loops on the machine to securely fasten the machine to the trailer or truck with straps, chains, cable, or ropes (Figure 36).

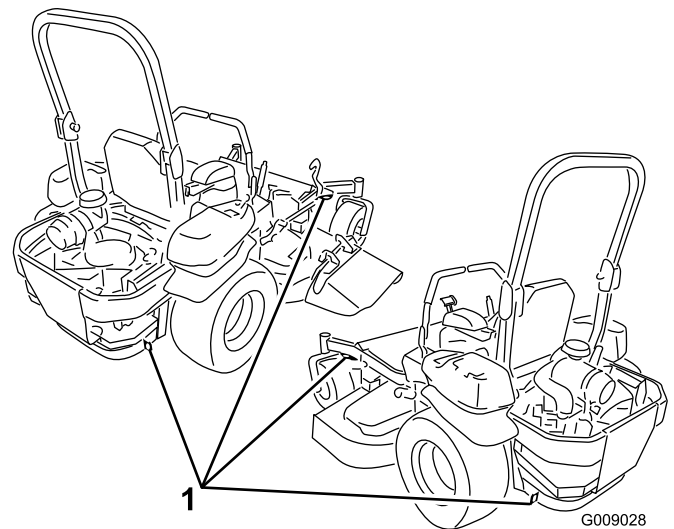

Figure 36

1. Traction unit tie down loops

Operating Tips

Maximizing Cutting Efficiency

For best mowing and maximum air circulation, operate the engine at the fast throttle position. Air is required to thoroughly cut grass clippings, so do not set the height of cut so low as to totally surround the mower by uncut grass. Always try to have one side of the mower free from uncut grass, which allows air to be drawn into the mower.

Cutting a Lawn for the First Time

Cut grass slightly longer than normal to ensure the cutting height of the mower does not scalp any uneven ground. However, the cutting height used in the past is generally the best one to use. When cutting grass longer than six inches tall, you may want to cut the lawn twice to ensure an acceptable quality of cut.

Cutting 1/3 of the Grass Blade

It is best to cut only about 1/3 of the grass blade. Cutting more than that is not recommended unless grass is sparse, or it is late fall when grass grows more slowly.

Alternating Mowing Direction

Alternate mowing direction to keep the grass standing straight. This also helps disperse clippings, which enhances decomposition and fertilization.

Mowing at Correct Intervals

Normally, mow every 4 days. However, grass grows at different rates at different times. So to maintain the same cutting height, which is a good practice, mow more often in early spring. As the grass growth rate slows in midsummer, mow less frequently. If you cannot mow for an extended period, first mow at a high cutting height; then mow again 2 days later at a lower height setting.

Choosing the Best Speed

To improve cut quality, use a slower ground speed in certain conditions.

Avoiding Cutting Too Low

If the cutting width of the mower is wider than the mower you previously used, raise the cutting height to ensure that uneven turf is not cut too short.

Cutting Long Grass

If the grass is ever allowed to grow slightly longer than normal, or if it contains a high degree of moisture, raise the cutting height higher than usual and cut the grass at this

setting. Then cut the grass again using the lower, normal setting.

Stopping

If the you must stop the forward motion of the machine while mowing, a clump of grass clippings may drop onto the lawn. To avoid this, move onto a previously cut area with the blades engaged.

Keeping the Underside of the Mower Clean

Clean clippings and dirt from the underside of the mower after each use. If grass and dirt build up inside the mower, cutting quality will eventually become unsatisfactory.

Maintaining the Blade

Maintain a sharp blade throughout the cutting season because a sharp blade cuts cleanly without tearing or shredding the grass blades. Tearing and shredding turns grass brown at the edges, which slows growth and increases the chance of disease. Check the cutter blades daily for sharpness, and for any wear or damage. File down any nicks and sharpen the blades as necessary. If a blade is damaged or worn, replace it immediately with a genuine Toro replacement blade.

Maintenance

Recommended Maintenance Schedule(s)

Maintenance Service Interval	Maintenance Procedure
After the first 100 hours	<ul style="list-style-type: none"> • Check the wheel lug nut torque. • Check the wheel hub slotted-nut torque. • Check the park brake adjustment.
After the first 250 hours	<ul style="list-style-type: none"> • Change the hydraulic filters and hydraulic oil when using any type of oil.
Before each use or daily	<ul style="list-style-type: none"> • Check the safety system. • Check the engine oil level. • Check the seat belt. • Check the rollover protection system (ROPS) knobs. • Clean the engine screen and the oil cooler. • Check and clean the hydraulic units. • Check the mower blades. • Clean the mower deck.
Every 50 hours	<ul style="list-style-type: none"> • Grease the mower deck spindles and idler arm. • Check the spark arrester (if equipped). • Check the tire pressure. • Inspect the belts for cracks and wear. • Check the hydraulic oil level.
Every 100 hours	<ul style="list-style-type: none"> • Lubricate the mower deck lift pivots. • Change the engine oil. (more often in dirty or dusty conditions) • Check and clean engine cooling fins and shrouds.
Every 150 hours	<ul style="list-style-type: none"> • Inspect the primary filter and air inlet screen.
Every 200 hours	<ul style="list-style-type: none"> • Change the engine oil filter. • Clean the engine oil cooler. • Check, clean and regap the spark plug. • Replace the fuel filter. (more often in dirty or dusty conditions).
Every 250 hours	<ul style="list-style-type: none"> • Change the hydraulic filters and hydraulic oil when using Mobil® 1 oil (more often in dirty or dusty conditions).
Every 300 hours	<ul style="list-style-type: none"> • Replace the primary air filter. (more often in dusty or sandy conditions) • Check the inner air filter.
Every 500 hours	<ul style="list-style-type: none"> • Check the wheel lug nut torque. • Check the wheel hub slotted-nut torque. • Adjust the caster pivot bearing. • Check the park brake adjustment. • Change the hydraulic filters and hydraulic oil when using Toro® HYPR-OIL™ 500 hydraulic oil (more often in dirty or dusty conditions).
Every 600 hours	<ul style="list-style-type: none"> • Replace the inner air filter.
Monthly	<ul style="list-style-type: none"> • Check the battery.
Yearly	<ul style="list-style-type: none"> • Grease the pump belt idler arm. • Grease the front caster pivots (more often in dirty or dusty conditions). • Repack the front caster wheel bearings (more often in dirty or dusty conditions). • Lubricate the caster wheel hubs.
Yearly or before storage	<ul style="list-style-type: none"> • Paint chipped surfaces. • Check all maintenance procedures listed above before storage.

Important: Refer to your engine operator's manual for additional maintenance procedures.

⚠ CAUTION

If you leave the key in the ignition switch, someone could accidentally start the engine and seriously injure you or other bystanders.

Remove the key from the ignition before you do any maintenance.

Lubrication

Lubricating the Machine

Grease more frequently when operating conditions are extremely dusty or sandy.

Grease Type: No. 2 general-purpose lithium-based or molybdenum-based grease

1. Disengage the blade control switch (PTO), move the motion control levers to the neutral locked position and set the parking brake.
2. Stop the engine, remove the key, and wait for all moving parts to stop before leaving the operating position.
3. Clean the grease fittings with a rag. Make sure to scrape any paint off the front of the fitting(s).
4. Connect a grease gun to the fitting. Pump grease into the fittings until grease begins to ooze out of the bearings.
5. Wipe up any excess grease.

Adding Light Oil or Spray Lubrication

Service Interval: Every 100 hours

Lubricate the deck lift pivots.

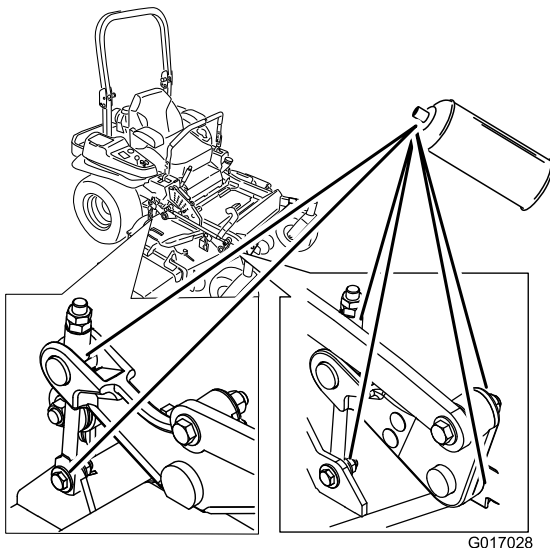

Figure 37

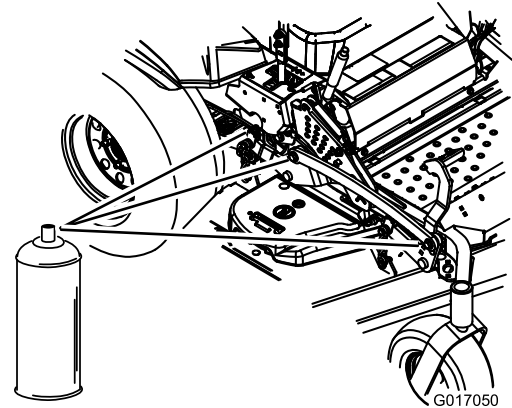

Figure 38

Greasing the Mower

Service Interval: Every 50 hours—Grease the mower deck spindles and idler arm.

Yearly—Grease the pump belt idler arm.

Yearly—Grease the front caster pivots (more often in dirty or dusty conditions).

Yearly—Repack the front caster wheel bearings (more often in dirty or dusty conditions).

Important: Make sure that the cutting unit spindles are full of grease weekly.

1. Disengage the blade control switch (PTO), move the motion control levers to the neutral locked position, and set the parking brake.
2. Stop the engine, remove the key, and wait for all moving parts to stop before leaving the operating position.
3. Grease the mower deck idler pulley pivot until grease come out the bottom (Figure 39).
4. Grease the 3 spindle bearings until grease comes out the lower seals (Figure 39).

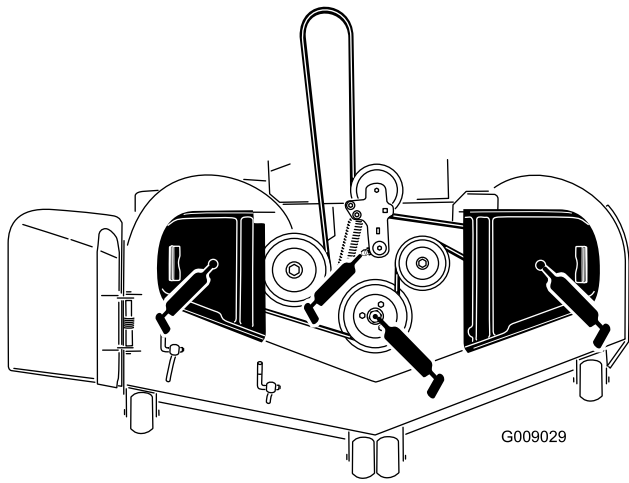

Figure 39

- Grease the drive belt idler arm (Figure 39).

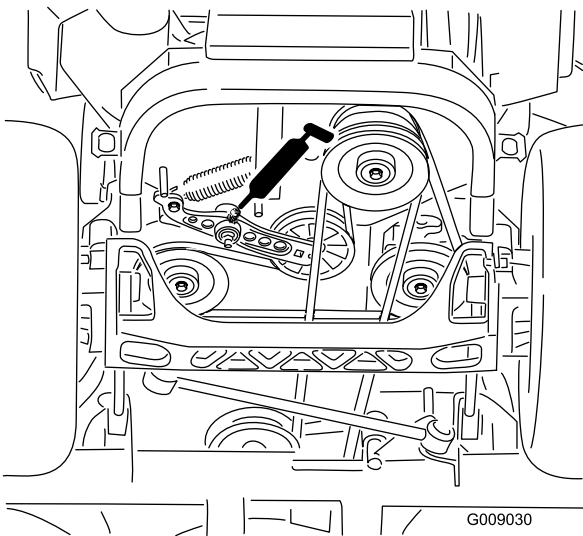

Figure 40

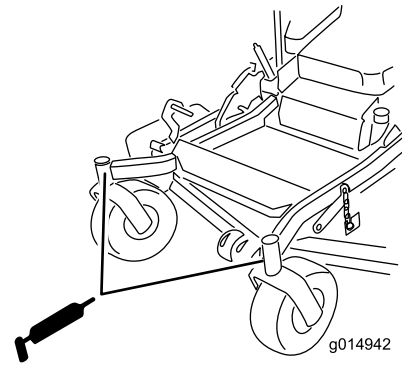

Figure 41

Lubricate the Caster Wheel Hubs

Service Interval: Yearly

- Stop the engine, wait for all moving parts to stop, and remove the key. Engage the parking brake.

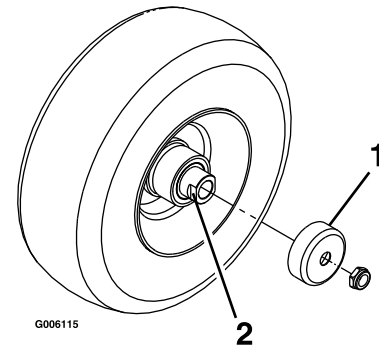

Figure 42

- Seal guard
- Spacer nut with wrench flats

- Remove the dust cap and adjust the caster pivots.

Note: Keep the dust cap off until greasing is complete. Refer to Adjusting the Caster Pivot Bearing (page 40).
- Remove the hex plug and thread a grease fitting into the hole.
- Pump grease into the fitting until it oozes out around the top bearing.
- Remove the grease fitting from the hole.
- Install the hex plug and dust cap (Figure 41).

- Raise the front of the machine up and support it with jack stands.
- Remove the caster wheel from the caster forks.
- Remove the seal guards from the wheel hub.
- Remove 1 of the spacer nuts from the axle assembly in the caster wheel.

Note: Note that thread locking adhesive has been applied to lock the spacer nuts to the axle. Remove the axle (with the other spacer nut still assembled to it) from the wheel assembly.

- Pry out the seals, and inspect the bearings for wear or damage and replace if necessary.
- Pack the bearings with a general-purpose grease.
- Insert 1 bearing and 1 new seal into the wheel.

Note: The seals must be replaced.

- If the axle assembly has had both spacer nuts removed (or broken loose), apply a thread locking adhesive to 1

spacer nut and thread it onto the axle with the wrench flats facing outward.

Note: Do not thread the spacer nut all of the way onto the end of the axle. Leave approximately 3 mm (1/8 inch) from the outer surface of the spacer nut to the end of the axle inside the nut.

10. Insert the assembled nut and axle into the wheel on the side of the wheel with the new seal and bearing.
11. With the open end of the wheel facing up, fill the area inside the wheel around the axle full of general-purpose grease.
12. Insert the second bearing and new seal into the wheel.
13. Apply a thread locking adhesive to the second spacer nut and thread it onto the axle with the wrench flats facing outward.
14. Torque the nut to 8-9 N-m (75-80 in-lb), loosen, then re-torque to 2-3 N-m (20-25 in-lb).

Note: Make sure that the axle does not extend beyond either nut.

15. Install the seal guards over the wheel hub and insert the wheel into the caster fork. Install the caster bolt and tighten the nut fully.

Important: To prevent seal and bearing damage, check the bearing adjustment often. Spin the caster tire. The tire should not spin freely (more than 1 or 2 revolutions) or have any side play. If the wheel spins freely, adjust the torque on the spacer nut until there is a slight amount of drag. Apply thread locking adhesive.

Engine Maintenance

Servicing the Air Cleaner

Service Interval: Every 150 hours

Every 300 hours/Yearly (whichever comes first)—Replace the primary air filter. (more often in dusty or sandy conditions)

Every 300 hours—Check the inner air filter.

Every 600 hours—Replace the inner air filter.

Note: Check the filters more frequently if the operating conditions are extremely dusty or sandy.

Removing the Filters

1. Disengage the PTO, move the motion control levers to the neutral locked position, and set the parking brake.
2. Stop the engine, remove the key, and wait for all moving parts to stop before leaving the operating position.
3. Release the latches on the air cleaner and pull the air inlet cover off the air cleaner body (Figure 43).
4. Clean the air inlet screen and cover.
5. Install the air inlet cover and secure it with the latches (Figure 43).

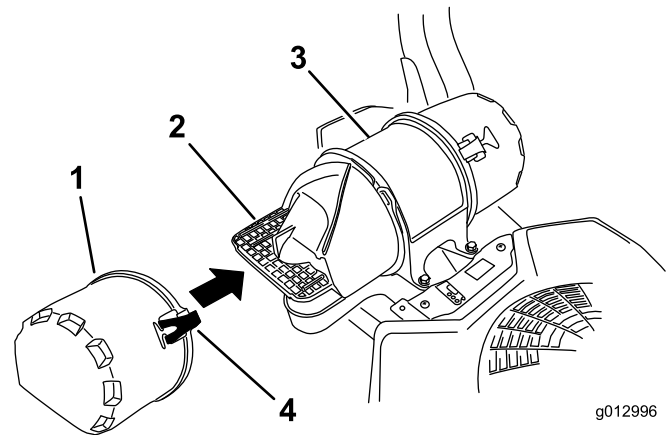

Figure 43

- | | |
|---------------------|---------------------|
| 1. Air inlet cover | 3. Air cleaner body |
| 2. Air inlet screen | 4. Latch |

6. Release the latches on the air cleaner and pull the air cleaner cover off the air cleaner body (Figure 44).
7. Clean the inside of the air cleaner cover with compressed air.
8. Gently slide the primary filter out of the air cleaner body (Figure 44).

Note: Avoid knocking the filter into the side of the body.

9. Remove the inner filter only if you intend to replace it.

Important: Never attempt to clean the inner filter. If the safety filter is dirty, then the primary filter is damaged. Replace both filters.

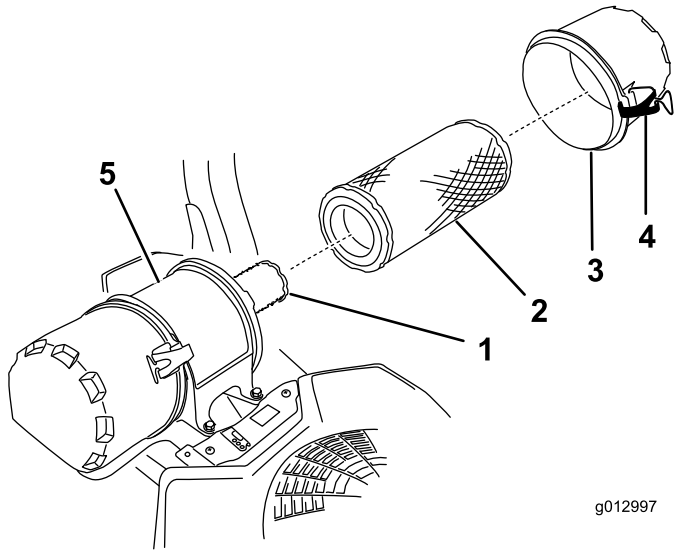

Figure 44

- | | |
|----------------------|---------------------|
| 1. Inner filter | 4. Latch |
| 2. Primary filter | 5. Air cleaner body |
| 3. Air cleaner cover | |

- Inspect the primary filter for damage by looking into the filter while shining a bright light on the outside of the filter.

Note: The holes in the filter will appear as bright spots. If the filter is damaged, discard it.

Servicing the Primary Filter

- If the primary filter is dirty, bent, or damaged, replace it.
- Do not clean the primary filter.

Servicing the Safety Filter

Replace the safety filter, never clean it.

Important: Never attempt to clean the safety filter. If the safety filter is dirty, then the primary filter is damaged. Replace both filters.

Installing the Filters

Important: To prevent engine damage, always operate the engine with both air filters and cover installed.

- If installing new filters, check each filter for shipping damage. Do not use a damaged filter.
- If the inner filter is being replaced, carefully slide it into the filter body (Figure 44).
- Carefully slide the primary filter over the inner filter (Figure 44).

Note: Ensure that the primary filter is fully seated by pushing on its outer rim while installing it.

Important: Do not press on the soft inside area of the filter.

- Install the air cleaner cover and secure the latches (Figure 44).

Servicing the Engine Oil

Oil Type: Detergent oil (API service class SJ or higher)

Oil Capacity: with a filter change, 58 ounces (1.7 L); with no filter change, 48 ounces (1.4 L)

Viscosity: See the table below.

USE THESE SAE VISCOSITY OILS

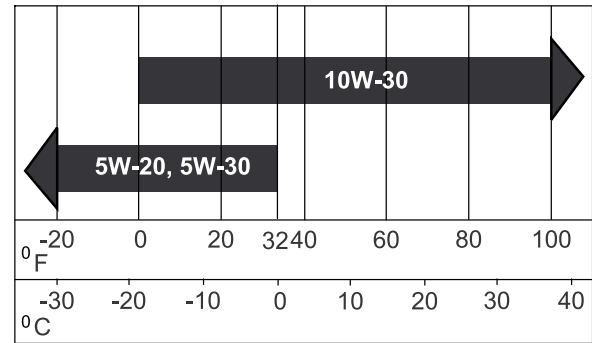

Figure 45

Note: Use of synthetic oil having 5W-20 or 5W-30 rating is acceptable, up to 4 degrees C (40 degrees F).

Note: Synthetic oils will provide better starting in extreme cold below -23 degrees C (-10 degrees F).

Checking the Engine Oil Level

Service Interval: Before each use or daily

Note: Check the oil when the engine is cold.

⚠ WARNING

Contact with hot surfaces may cause personal injury.

Keep hands, feet, face, clothing and other body parts away from the muffler and other hot surfaces.

Important: Do not overfill the crankcase with oil because damage to the engine may result. Do not run engine with oil below the low mark because the engine may be damaged.

- Disengage the PTO, move the motion control levers to the neutral locked position and set the parking brake.
- Stop the engine, remove the key, and wait for all moving parts to stop before leaving the operating position (Figure 46).

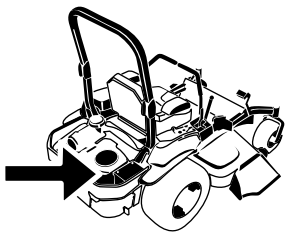

G008804

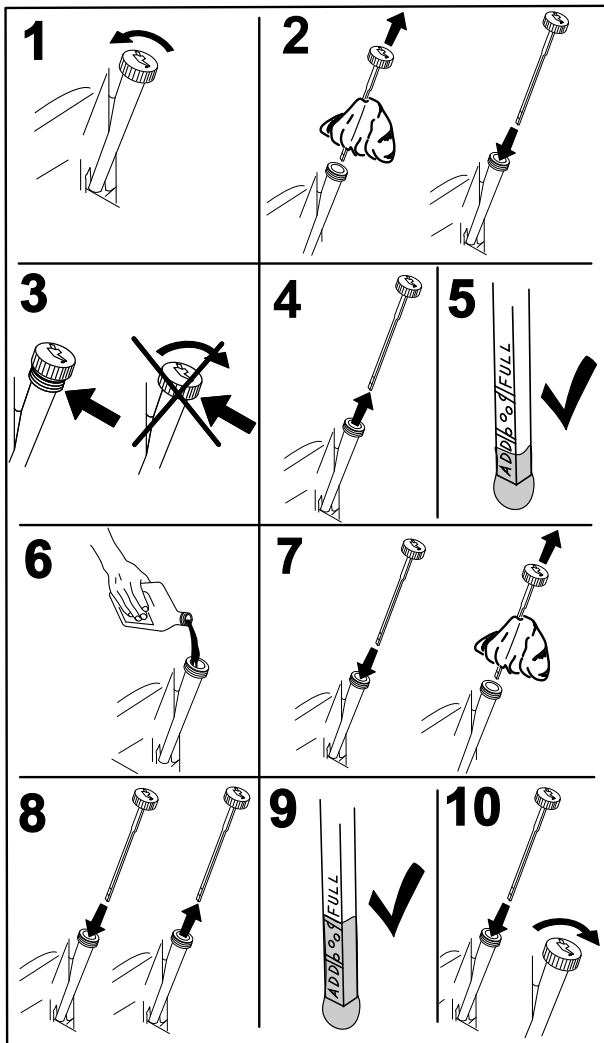

G008792

Figure 46

Changing the Engine Oil

Service Interval: Every 100 hours (more often in dirty or dusty conditions)

Note: Dispose of the used oil at a recycling center.

1. Park the machine so that the rear is slightly lower than the front to ensure the oil drains completely.
2. Disengage the PTO, move the motion control levers to the neutral locked position and set the parking brake.
3. Stop the engine, remove the key, and wait for all moving parts to stop before leaving the operating position (Figure 47).

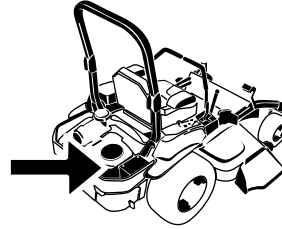

G008804

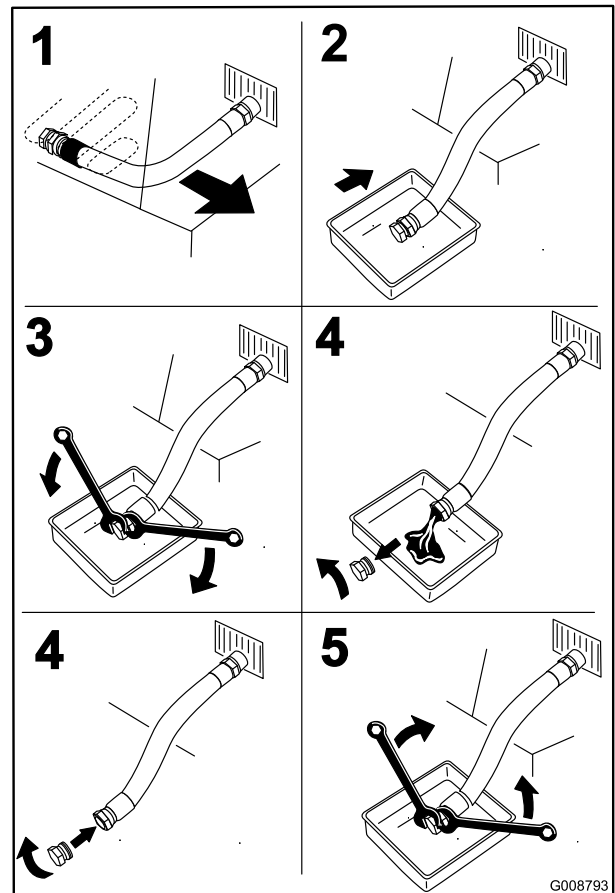

G008793

Figure 47

- Slowly pour approximately 80% of the specified oil into the filler tube and slowly add the additional oil to bring it to the **Full** mark (Figure 48).

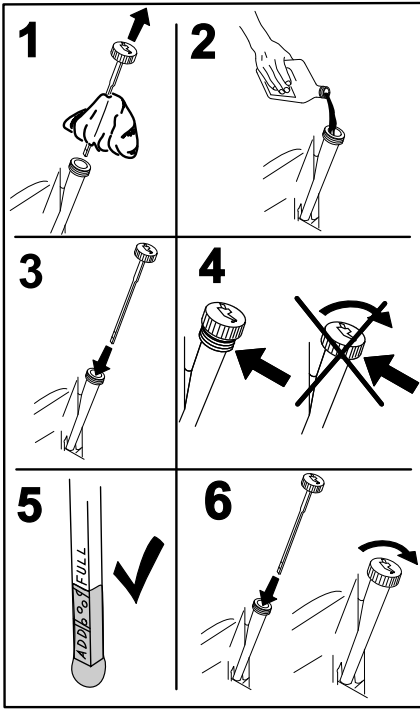

Figure 48

- Start the engine and drive to a flat area. Check the oil level again.

Changing the Engine Oil Filter

Service Interval: Every 200 hours

Note: Change the engine oil filter more frequently when operating conditions are extremely dusty or sandy.

- Drain the oil from the engine; refer to Changing the Engine Oil (page 32).
- Change the engine oil filter (Figure 49).

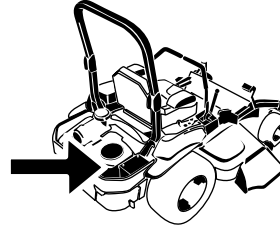

G008804

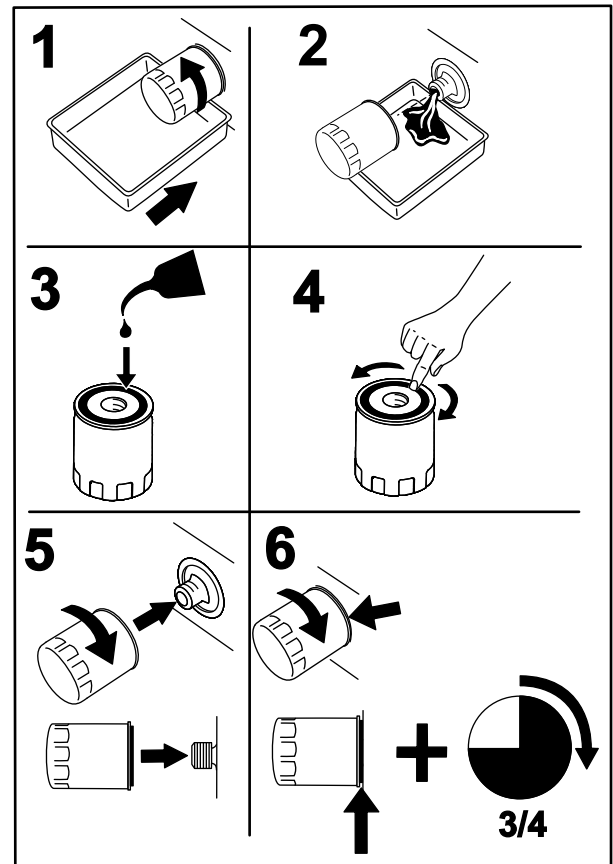

Figure 49

G008748

Note: Ensure the oil filter gasket touches the engine and then an extra 3/4 turn is completed.

- Fill the crankcase with the proper type of new oil; refer to Changing the Engine Oil (page 32).

Servicing the Engine Oil Cooler

Service Interval: Every 200 hours

1. Keep the oil cooler free of debris. by cleaning the fins with a brush.
2. Remove the bolts holding the oil cooler to the engine housing .
3. Clean the inside of the oil cooler with a brush.
4. Install the oil cooler to the engine housing.

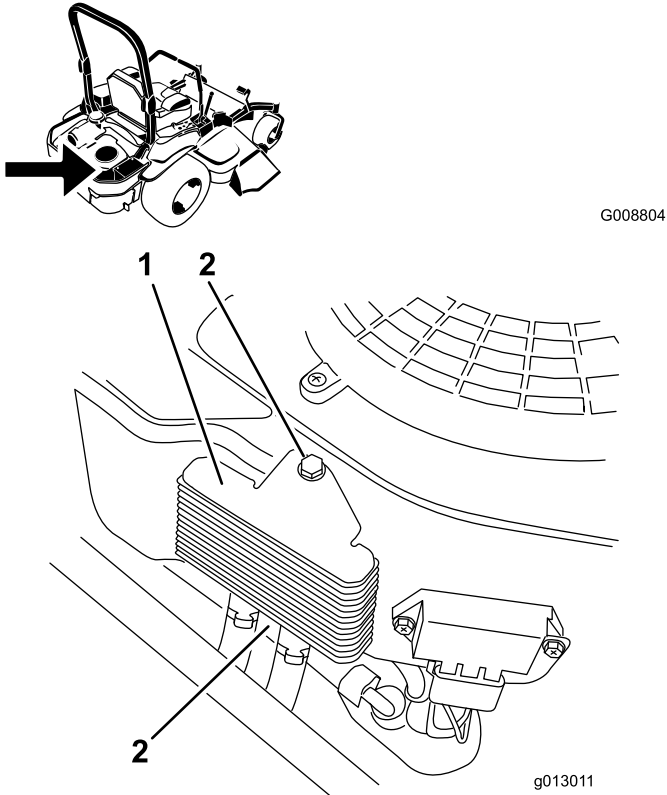

Figure 50

1. Engine oil cooler
2. Bolts

Servicing the Spark Plug

Service Interval: Every 200 hours—Check, clean and regap the spark plug.

Make sure the air gap between the center and side electrodes is correct before installing the spark plug. Use a spark plug wrench for removing and installing the spark plug(s) and a gapping tool/feeler gauge to check and adjust the air gap. Install a new spark plug(s) if necessary.

Type : Champion® XC12YC, or equivalent

Air Gap: 0.76 mm (0.030 inch)

Removing the Spark Plug

1. Stop the engine, remove the key, and wait for all moving parts to stop before leaving the operating position.
2. Disengage the PTO, move the motion control levers to the neutral locked position and set the parking brake.
3. Remove the left hydraulic unit shroud in the order listed with Figure 51. This gives you access to the front spark plug.

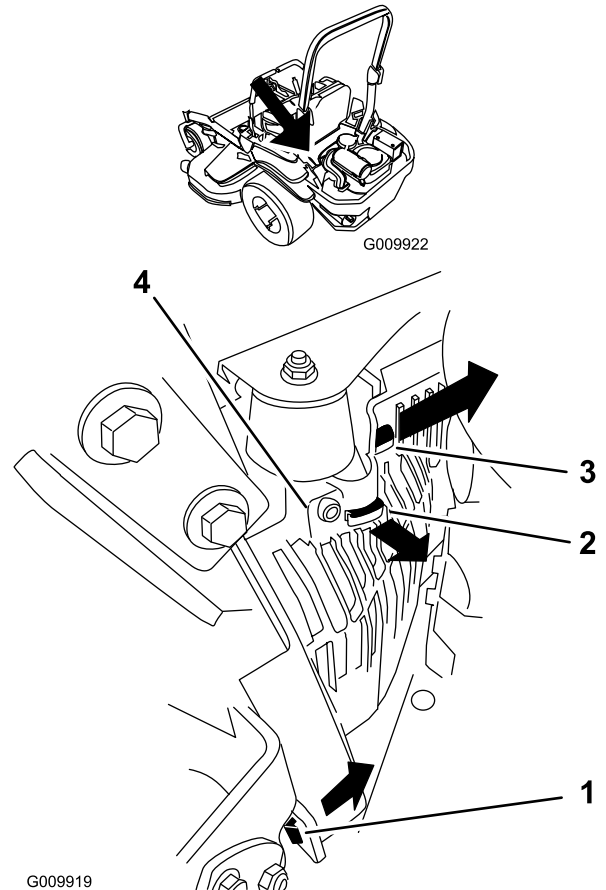

Figure 51

1. Pull this tab out to the side in the direction of the arrow
2. Pull the shroud off of this frame tab in the direction of the arrow
3. Pull the shroud off of this frame tab in the direction of the arrow
4. Shroud

- Remove the spark plug.

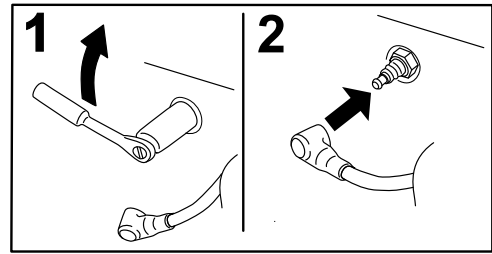
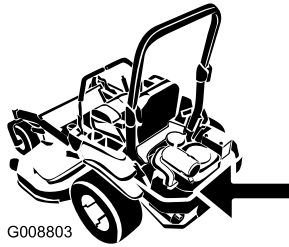

Figure 54

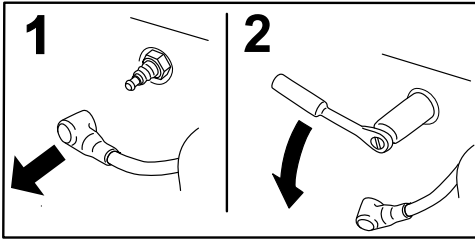

Figure 52

- Install the left hydraulic unit shroud (Figure 51).

Checking the Spark Plug

Important: Replace the spark plug(s) when it has: a black coating, worn electrodes, an oily film, cracks or reuse is questionable.

If you see light brown or gray on the insulator, the engine is operating properly. A black coating on the insulator usually means the air cleaner is dirty.

Set the gap to 0.76 mm (0.030 inches).

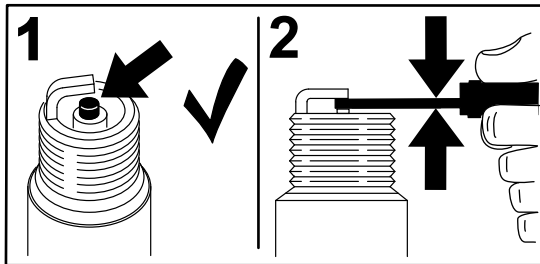

Figure 53

Installing the Spark Plug

Tighten the spark plug(s) to 24.4–29.8 N-m (18-22 ft.-lb).

Check the Spark Arrester (if equipped)

Service Interval: Every 50 hours

⚠ WARNING

Hot exhaust system components may ignite gasoline vapors even after the engine is stopped. Hot particles exhausted during engine operation may ignite flammable materials. Fire may result in personal injury or property damage.

Do not refuel or run engine unless spark arrester is installed.

- Stop the engine, wait for all moving parts to stop, and remove the key. Engage the parking brake.
- Wait for the machine to cool.
- If there are any breaks in the screen or welds are observed, replace the arrester.
- If the screen is plugged, remove the arrester and shake loose any particles out of the arrester and clean the screen with a wire brush (soak in solvent if necessary). Install the arrester on an exhaust outlet.

Fuel System Maintenance

⚠ WARNING

Fuel system components are under high pressure. The use of improper components can result in system failure, gasoline leakage, and possible explosion.

Use only approved fuel lines and fuel filters.

Servicing the Electronic Fuel Injection System

This machine contains an electronic fuel injection system. It controls the fuel flow under different operating conditions.

The electronic control unit (ECU) continuously monitors the operation of the EFI system.

If a problem or fault within the system is detected, the malfunction indicator light (MIL) is illuminated. The MIL is the red light located in the right console panel.

Once the MIL illuminates, initial trouble shooting checks should be made. Refer to the MIL section under Troubleshooting.

If these checks do not correct the problem, further diagnosis and servicing by an Authorized Service Dealer is necessary.

Replacing the Low Pressure Fuel Filter

Service Interval: Every 200 hours/Yearly (whichever comes first) (more often in dirty or dusty conditions).

The fuel filter is located near the engine on the front or rear side of the engine.

1. Disengage the PTO, move the motion control levers to the neutral locked position, and set the parking brake.
2. Stop the engine, remove the key, and wait for all moving parts to stop before leaving the operating position.
3. Allow the machine to cool down.
4. Stop the engine, remove the key, and wait for all moving parts to stop before leaving the operating position.
5. Close the fuel shutoff valve under the seat (Figure 55).

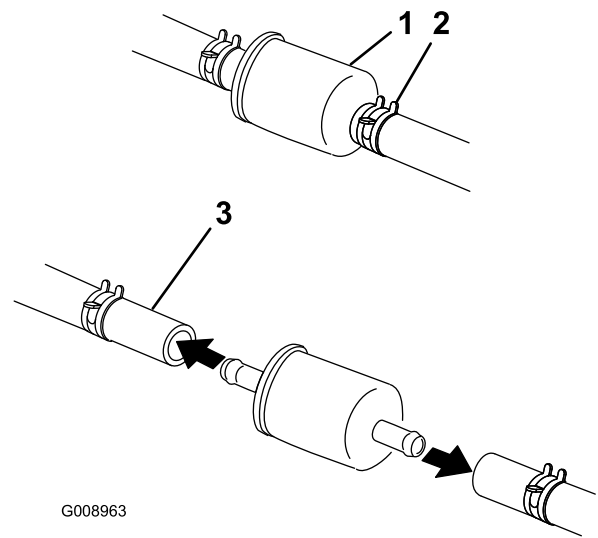

G008963

Figure 55

1. Fuel filter
2. Hose clamp
3. Fuel line

6. Squeeze the ends of the hose clamps together and slide them away from the filter (Figure 55).
7. Remove the filter from the fuel lines.
8. Install a new filter and move the hose clamps close to the filter (Figure 55).
9. Open the fuel shutoff valve.

Note: It is important to reinstall the fuel line hoses and secure with plastic ties the same as they were originally installed at the factory to keep the fuel line away from components that could cause fuel line damage.

Servicing the High Pressure Fuel Filter

Do not attempt to service the high pressure fuel filter. The high pressure filter is integrated within the fuel pump module. The fuel filter and other components inside the fuel pump module are not serviceable. **Do not** attempt to open the fuel pump module.

Ensure that an Authorized Service Dealer replaces the fuel pump module with the high pressure fuel filter.

Servicing the Fuel Tank

Do not attempt to drain the fuel tank. Ensure that an Authorized Service Dealer drains the fuel tank and services any components of the fuel system.

Electrical System Maintenance

Servicing the Battery

Service Interval: Monthly

⚠ WARNING

CALIFORNIA Proposition 65 Warning

Battery posts, terminals, and related accessories contain lead and lead compounds, chemicals known to the State of California to cause cancer and reproductive harm. Wash hands after handling.

⚠ DANGER

Battery electrolyte contains sulfuric acid which is a deadly poison and causes severe burns.

Do not drink electrolyte and avoid contact with skin, eyes or clothing. Wear safety glasses to shield your eyes and rubber gloves to protect your hands.

Removing the Battery

⚠ WARNING

Battery terminals or metal tools could short against metal machine components causing sparks. Sparks can cause the battery gasses to explode, resulting in personal injury.

- When removing or installing the battery, do not allow the battery terminals to touch any metal parts of the machine.
- Do not allow metal tools to short between the battery terminals and metal parts of the machine.

⚠ WARNING

Incorrect battery cable routing could damage the machine and cables causing sparks. Sparks can cause the battery gasses to explode, resulting in personal injury.

- Always Disconnect the negative (black) battery cable before disconnecting the positive (red) cable.
 - Always Reconnect the positive (red) battery cable before reconnecting the negative (black) cable.
1. Disengage the blade control switch (PTO), move the motion control levers to the neutral locked position and set the parking brake.
 2. Stop the engine, remove the key, and wait for all moving parts to stop before leaving the operating position.
 3. First disconnect the negative battery cable (black) from the negative (-)(black) battery terminal (Figure 56).
 4. Slide the red terminal boot off the positive (red) battery terminal and remove the positive (+)(red) battery cable (Figure 56).
 5. Remove the wing nut securing the battery clamp (Figure 56).
 6. Remove the clamp (Figure 56).
 7. Remove the battery.

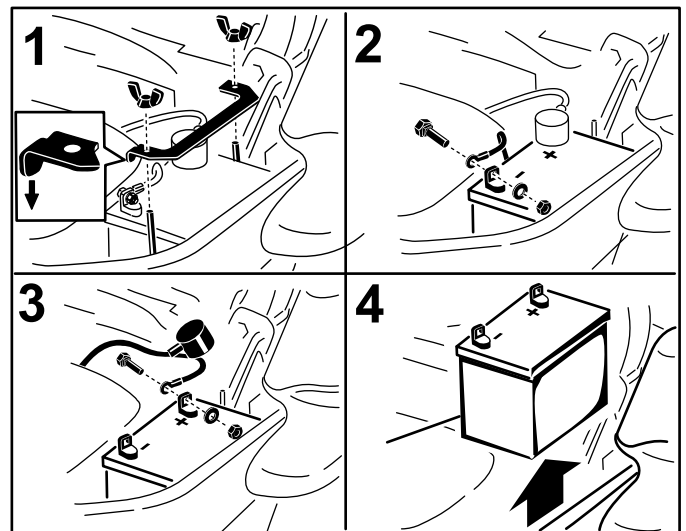

g014731

Figure 56

1. Remove the wing nut and clamp
2. Remove the negative battery cable before the positive
3. Remove the positive battery cable
4. Remove battery

Installing the Battery

1. Position battery in the tray with the terminal posts opposite from the hydraulic tank (Figure 56).
2. First, install the positive (red) battery cable to positive (+) battery terminal.
3. Then install the negative (black) battery cable and ground wire to the negative (-) battery terminal.
4. Secure the cables with 2 bolts, 2 washers, and 2 locknuts (Figure 56).
5. Slide the red terminal boot onto the positive (red) battery post.
6. Install the clamp and secure it with the wing nut (Figure 56).

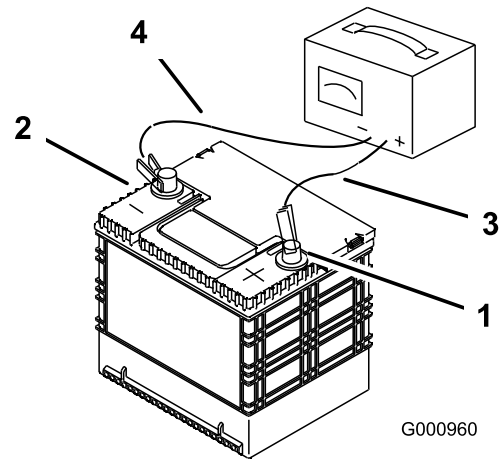

Figure 57

- | | |
|--------------------------|---------------------------|
| 1. Positive Battery Post | 3. Red (+) Charger Lead |
| 2. Negative Battery Post | 4. Black (-) Charger Lead |

Charging the Battery

⚠ WARNING

Charging the battery produces gasses that can explode.

Never smoke near the battery and keep sparks and flames away from battery.

Important: Always keep the battery fully charged (1.265 specific gravity). This is especially important to prevent battery damage when the temperature is below 32°F (0°C).

1. Charge battery for 10 to 15 minutes at 25 to 30 amps or 30 minutes at 10 amps.
2. When the battery is fully charged, unplug the charger from the electrical outlet, then disconnect the charger leads from the battery posts (Figure 57).
3. Install the battery in the machine and connect the battery cables, refer to Installing the Battery (page 38).

Note: Do not run the machine with the battery disconnected, electrical damage may occur.

Servicing the Fuses

The electrical system is protected by fuses. It requires no maintenance, however, if a fuse blows check the component/circuit for a malfunction or short.

1. The fuses are located on right hand console next to the seat (Figure 58).
2. To replace the fuses, pull out on the fuse to remove it.
3. Install a new fuse (Figure 58).

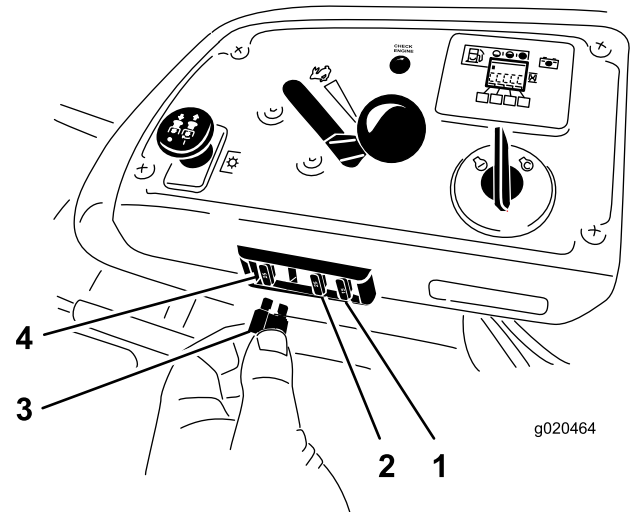

Figure 58

- | | |
|-----------------------------|---------------|
| 1. Optional accesory-15 amp | 4. Main-25amp |
| 2. Charge-25amp | 5. Console |
| 3. PTO-10amp | |

Drive System Maintenance

Checking the Seat Belt

Service Interval: Before each use or daily

Visually inspect seat belt for wear, cuts, and proper operation of retractor and buckle. Replace before operating if damaged.

Checking the Rollover Protection System (ROPS) Knobs

Service Interval: Before each use or daily

⚠ WARNING

To avoid injury or death from rollover: keep the roll bar in the fully raised locked position and use the seat belt.

Ensure the seat is secured to the machine.

Check that both the mounting hardware and the knobs are in good working condition. Make sure the knobs are fully engaged with the ROPS in the raised position. The upper hoop of the roll bar may need to be pushed forward or pulled rearward to get both knobs fully engaged.

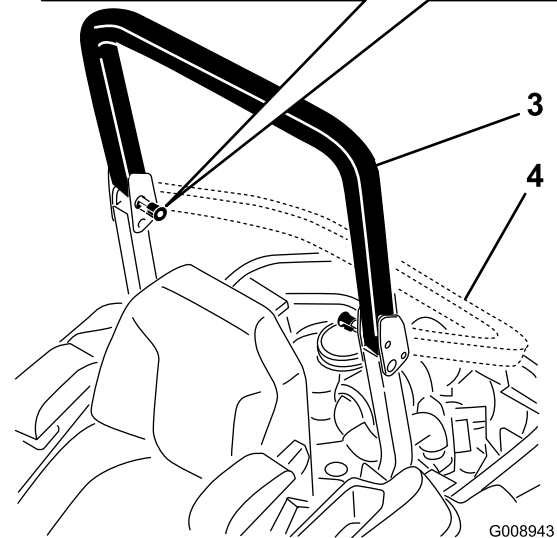
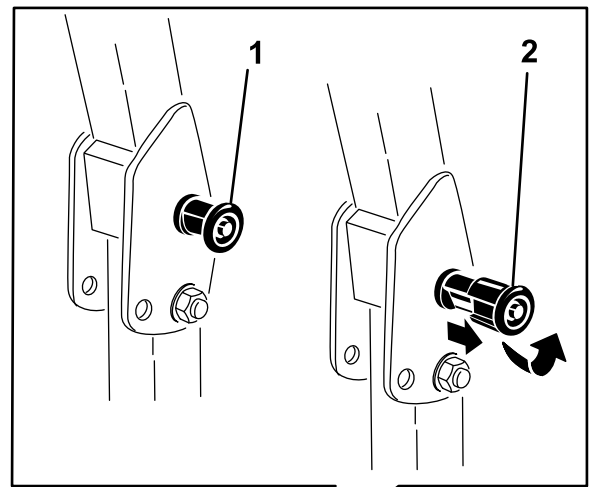

Figure 59

1. ROPS knob (locked position)
2. Pull ROPS knob out and rotate 90 degrees to change roll bar position
3. Roll bar in the upright position
4. Roll bar in the folded position

Adjusting the Tracking

1. Disengage the blade control switch (PTO).
2. Drive to an open flat area, move the motion control levers to the neutral locked position.
3. Move the throttle midway between fast and slow.
4. Move both motion control levers all the way forward until they both hit the stops in the T-slot.
5. Check which way the machine tracks.
6. If it tracks to the right, loosen the bolts and adjust the left stop plate rearward on the left T-slot until the machine tracks straight (Figure 60).
7. If it tracks to the left, loosen the bolts and adjust the right stop plate rearward on the right T-slot until the machine tracks straight (Figure 60).
8. Tighten the stop plate (Figure 60).

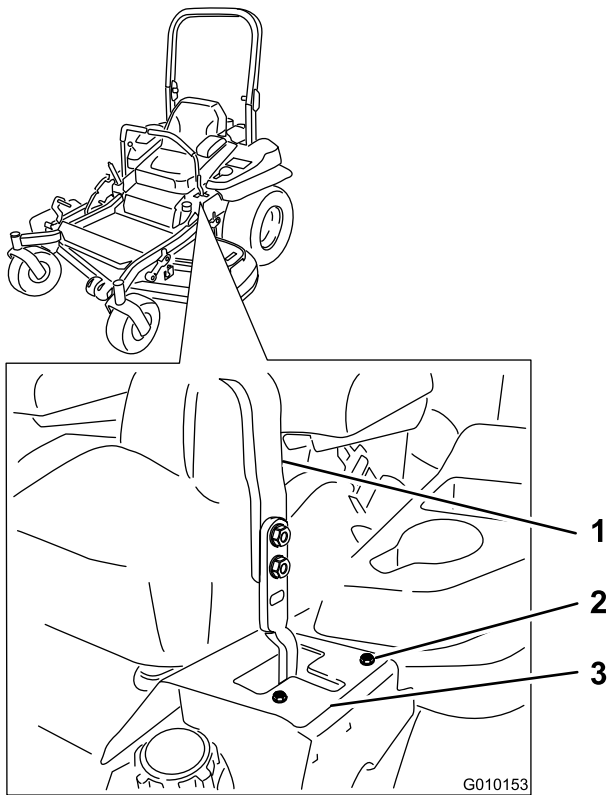

Figure 60

Left control lever shown

- | | |
|------------------|---------------|
| 1. Control lever | 3. Stop plate |
| 2. Bolt | |

Checking the Tire Pressure

Service Interval: Every 50 hours/Monthly (whichever comes first)

Maintain the air pressure in the front and rear tires at 13 psi (90 kPa). Uneven tire pressure can cause uneven cut. Check the tires when they are cold to get the most accurate pressure reading.

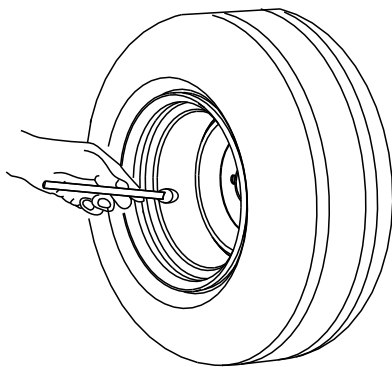

G001055

Figure 61

Checking the Wheel Lug Nuts

Check and torque the wheel lug nuts to 122-129 N-m (90-95 ft-lb).

Checking the Wheel Hub Slotted Nut

Service Interval: After the first 100 hours

Every 500 hours

Check and ensure that the torque of the slotted nut is 286 to 352 N-m (211 to 260 ft-lb).

Note: Do not use anti-seize on wheel hub.

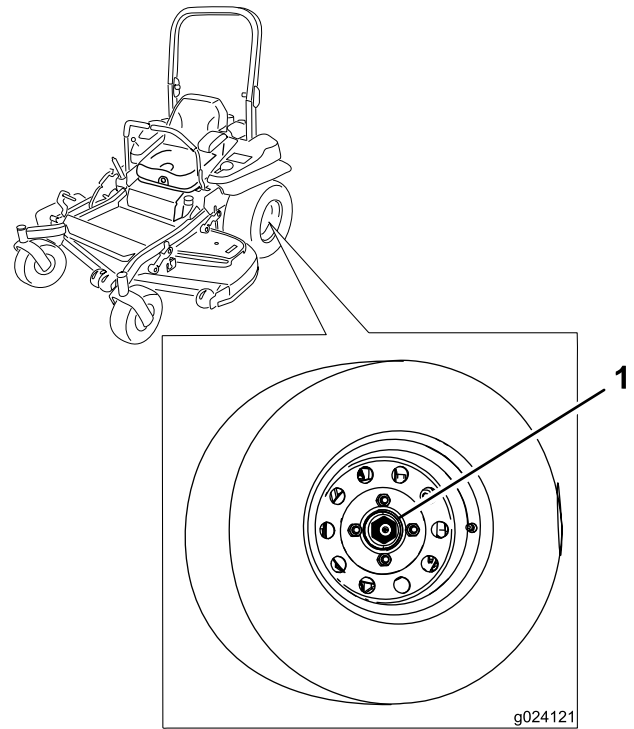

Figure 62

1. Slotted nut

Adjusting the Caster Pivot Bearing

Service Interval: Every 500 hours/Yearly (whichever comes first)

1. Disengage the blade control switch (PTO), move the motion control levers to the neutral locked position and set the parking brake.
2. Stop the engine, remove the key, and wait for all moving parts to stop before leaving the operating position.
3. Remove the dust cap from caster and tighten lock nut (Figure 63).

4. Tighten the locknut until the spring washers are flat and then back off a 1/4 turn to properly set the pre-load on the bearings (Figure 63).

Important: Make sure the spring washers are installed correctly as shown in Figure 63.

5. Install the dust cap (Figure 63).

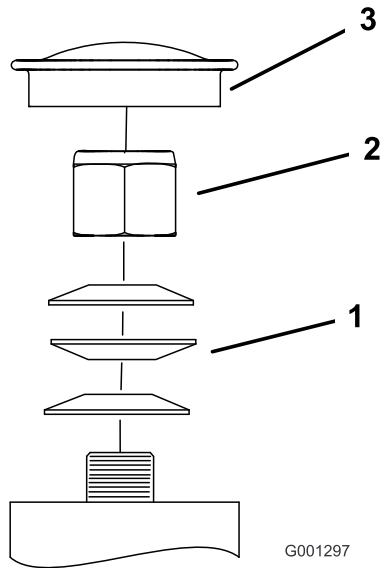

Figure 63

- | | |
|-------------------|-------------|
| 1. Spring Washers | 3. Dust Cap |
| 2. Lock Nut | |

Using the Clutch Shim

Some later model year units have been built with clutches that contain a brake shim. When the clutch brake has worn to the point where the clutch no longer engages consistently, the shim can be removed to extend the clutch life.

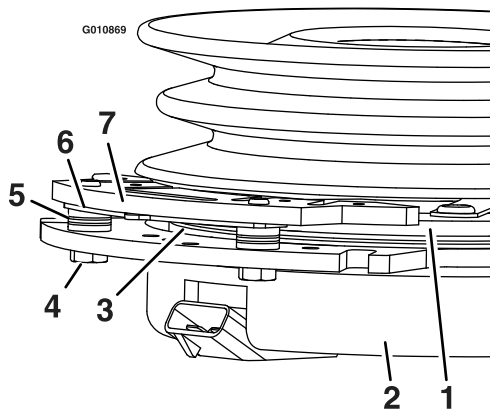

Figure 64

- | | |
|------------------------|-----------------|
| 1. Armature | 5. Brake spacer |
| 2. Field shell | 6. Re-gap shim |
| 3. Rotor | 7. Brake pole |
| 4. Brake mounting bolt | |

Removing the Clutch Shim

1. Stop the engine, wait for all moving parts to stop, and remove the key.
2. Engage the parking brake and allow the machine to cool completely before starting these instructions.
3. Using an air compressor, blow out any debris from under the brake pole and around the brake spacers.

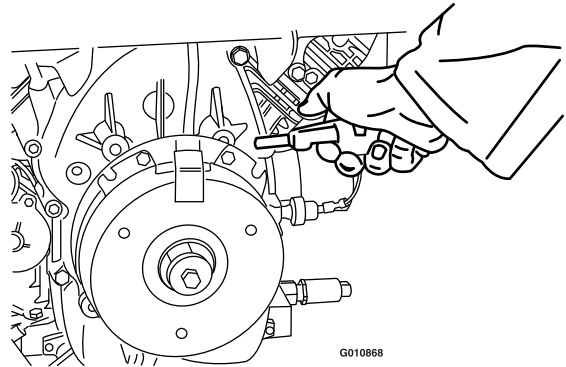

Figure 65

4. Check the condition of the wire harness leads, connectors, and terminals. Clean or repair as necessary.
5. Verify that 12V is present at the clutch connector when the PTO switch is engaged.
6. Measure the gap between the rotor and armature. If the gap is greater than 1 mm (0.04 inch), proceed with the following steps:
 - A. Loosen both brake mounting bolts one-half to one full turn as shown below.

Note: Do not remove the brake pole from the field shell/armature. The brake pole has worn to match the armature and needs to continue to match after the shim is removed to ensure proper brake torque.

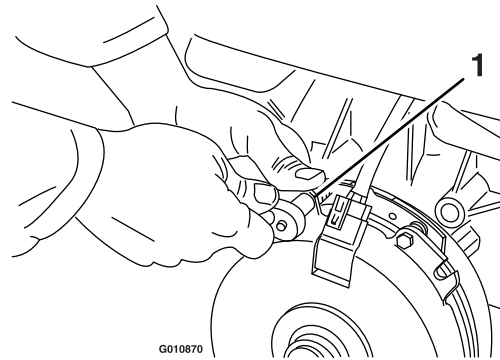

Figure 66

1. Brake mounting bolt

- B. Using needle nose pliers, or by hand, take hold of the tab, and remove the shim (Do not discard the shim until proper clutch function has been confirmed).

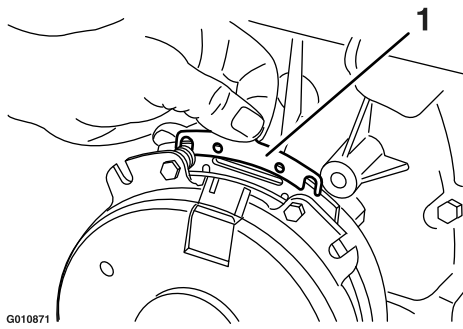

Figure 67

1. Shim

-
- C. Using a pneumatic line, blow out any debris from under the brake pole and around the brake spacers.
 - D. Re-torque each bolt (M6 x 1) to 13 N-m (10 ft-lb +/-0.7 N-m (0.5 ft-lb)).
 - E. Using a 0.010 inch thick feeler gauge, verify that a gap is present between the rotor and armature face on both sides of the brake pole as shown.

Note: Due to the way the rotor and armature faces wear (peaks and valleys) it is sometimes difficult to measure the true gap.

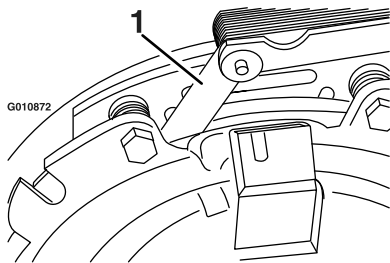

Figure 68

1. Feeler gauge

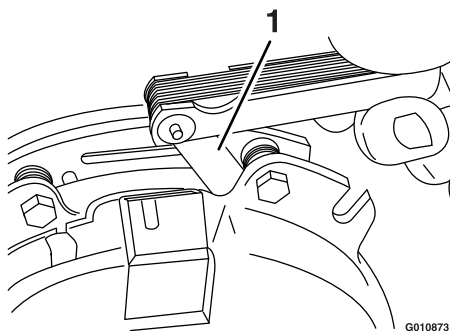

Figure 69

1. Feeler gauge

-
- If the gap is less than 0.010 inch, then reinstall the shim and reference the Troubleshooting (page 59) section.
 - If the gap is sufficient, proceed to the safety check in step F.

F. Perform the following safety check:

- i. Sit on the seat and start the engine.
- ii. Make sure the blades Do not engage with the PTO switch “off” and the clutch disengaged.

If the clutch does not disengage, install the shim, and reference the Troubleshooting (page 59) section.

- iii. Engage and disengage the PTO switch 10 consecutive times to ensure the clutch is functioning properly. If the clutch does not engage properly, reference the Troubleshooting (page 59) section.

Cooling System Maintenance

Cleaning the Engine Screen and Engine Oil Cooler

Service Interval: Before each use or daily

Remove any build-up of grass, dirt, or other debris from the oil cooler (Figure 70).

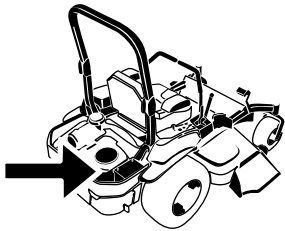

G008804

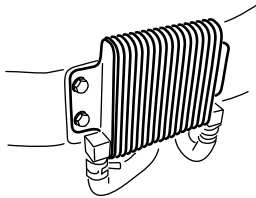

G009191

Figure 70

Before each use remove any build-up of grass, dirt, or other debris from the engine screen. This will help ensure adequate cooling and correct engine speed and will reduce the possibility of overheating and mechanical damage to the engine (Figure 71).

Cleaning the Engine Cooling Fins and Shrouds

Service Interval: Every 100 hours/Yearly (whichever comes first)

1. Disengage the PTO and set the parking brake.
2. Stop the engine, remove the key, and wait for all moving parts to stop before leaving the operating position.
3. Remove the air intake screen, recoil starter, and fan housing (Figure 71).
4. Clean the debris and grass from the engine parts.
5. Install air intake screen, recoil starter, and fan housing (Figure 71).

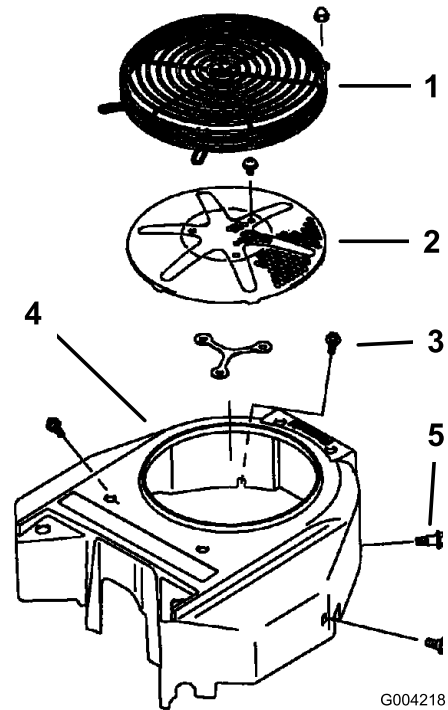

G004218

Figure 71

- | | |
|-----------------------------|----------------|
| 1. Engine guard | 4. Fan housing |
| 2. Engine air intake screen | 5. Screw |
| 3. Bolt | |

Check and Clean the Hydraulic Units

Service Interval: Before each use or daily

1. Disengage the PTO and set the parking brake.
2. Stop the engine, remove the key, and wait for all moving parts to stop before leaving the operating position.
3. Move the seat forward.
4. Clean the debris and grass from the hydraulic units (Figure 72).
5. Position the seat.

Brake Maintenance

Adjusting the Parking Brake

Service Interval: After the first 100 hours

Every 500 hours thereafter

Check to make sure brake is adjusted properly. Perform this procedure after the first 100 hours or when a brake component has been removed or replaced.

1. Drive the machine onto a level surface.
2. Disengage the blade control switch (PTO), move the motion control levers to the neutral locked position and set the parking brake.
3. Stop the engine, wait for all moving parts to stop, and remove the key.
4. Raise the back of the machine up and support the machine with jack stands.

⚠ DANGER

Mechanical or hydraulic jacks may fail to support machine and cause a serious injury.

- Use jack stand when supporting machine.
- Do not use hydraulic jacks.

5. Remove the rear tires from the machine.
6. Remove any debris from the brake area.
7. Rotate the drive wheel release handle to the **released** position. Refer to Using the Drive Wheel Release Valves (page 24).
8. Measure the overall length of the compression spring. Ensure the correct length is between 3.8 and 4.0 cm (1-1/2 and 1-9/16 inches). If the spring length is within this range, no adjustment is needed. If it is not, proceed to step 9.
9. Hold the threaded rod end with a tool and adjust the lock nut until the spring length is between 3.8 and 4.0 cm (1-1/2 and 1-9/16 inches) (Figure 73). Do not allow the cable to turn when the nuts are being loosened.

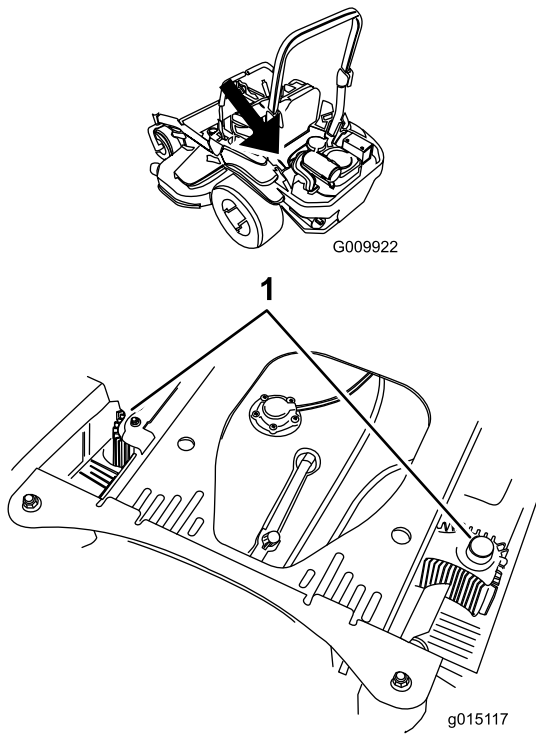

Figure 72

1. Hydraulic units

Belt Maintenance

Inspecting the Belts

Service Interval: Every 50 hours

Check the belts for squealing when the belt is rotating, blades slipping when cutting grass, frayed belt edges, burn marks, and cracks are signs of a worn mower belt. Replace the mower belt if any of these conditions are evident.

Replacing the Mower Belt

Squealing when the belt is rotating, blades slipping when cutting grass, frayed belt edges, burn marks and cracks are signs of a worn mower belt. Replace the mower belt if any of these conditions are evident.

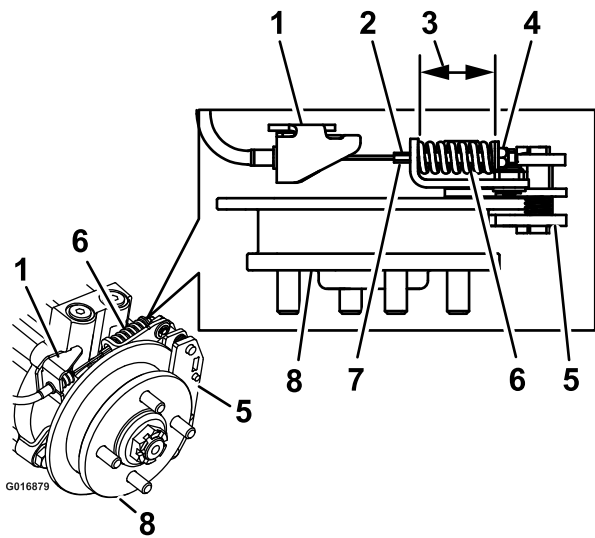

Figure 73

Left Hand Brake Shown

- | | |
|---------------------------|-----------------------|
| 1. Cable anchor | 5. Caliper |
| 2. Hold threaded rod here | 6. Compression spring |
| 3. Measure | 7. Threaded rod |
| 4. Lock nut | 8. Hub |
-
- Disengage the park brake. Turn the wheel hub by hand in both directions relative to the caliper; no drag of the caliper pad on the wheel hub is desired.
 - If there is no movement between the hub and the caliper then repeat the adjustment (ensure the drive release valves are in the **released** position on the hydros).
 - After adjusting the brakes on both sides of the mower, cycle the brake handle a minimum of 6 times to allow the cable to seat into the sheath and mounting tabs.
 - Recheck the spring length; engage the park brake and repeat steps 8 through 11 if the length is not in the correct range.
 - Rotate the drive wheel release handle to the **operating** position. Refer to Using the Drive Wheel Release Valves (page 24).
 - Install the rear tires and torque lug nuts between 122 and 129 N-m (90 and 95 ft-lb).
 - Remove jack stands.

- Disengage the PTO, move the motion control levers to the neutral locked position, and set the parking brake.
- Stop the engine, remove the key, and wait for all moving parts to stop before leaving the operating position.
- Lower the mower to the 76mm (3 inch) height of cut.
- Remove the belt covers (Figure 74).

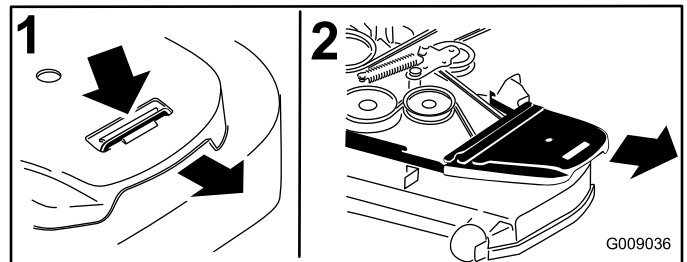

Figure 74

- Push tab down
- Remove belt cover

-
- Use a ratchet in the square hole in the idler arm to remove tension on the idler spring (Figure 75).
 - Remove the belt from the mower deck pulleys.
 - Remove the belt guide on the spring loaded idler arm shown in Figure 75.
 - Remove the existing belt.
 - Install the new belt around the mower pulleys and the clutch pulley under the engine (Figure 75).

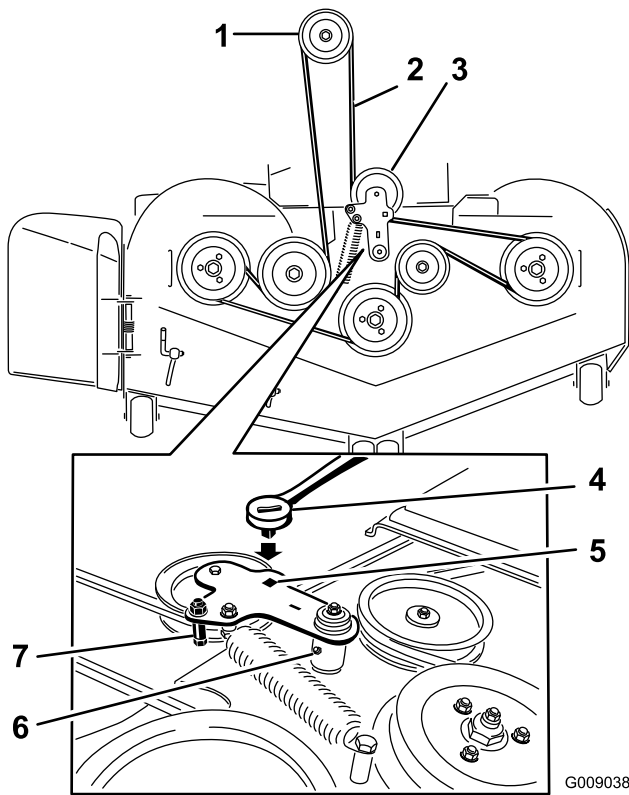

Figure 75

- | | |
|-------------------------------|---|
| 1. Clutch pulley | 5. Square hole in the idler arm for the ratchet |
| 2. Mower belt | 6. Idler grease fitting |
| 3. Spring loaded idler pulley | 7. Belt guide |
| 4. Ratchet | |

-
10. Install the belt guide on the idler arm shown in Figure 75.
 11. Using the ratchet in the square hole, install the idler spring (Figure 75).
Make sure that the spring ends are seated in the anchor grooves.
 12. Install the belt covers (Figure 76).

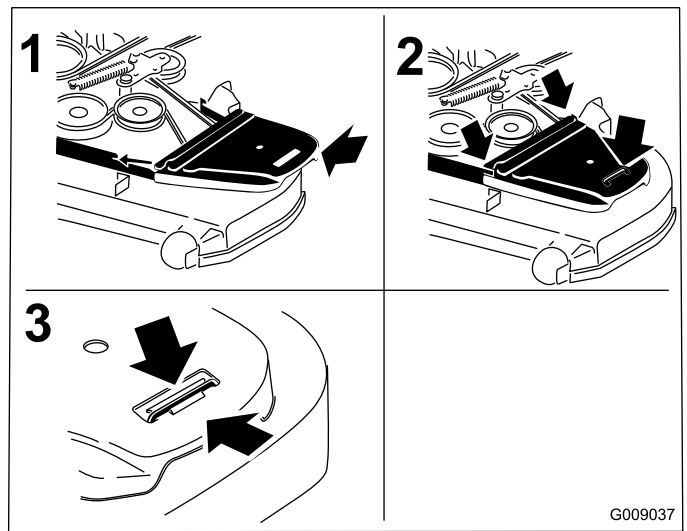

Figure 76

1. Position the belt cover
2. Slide belt cover under the side catches
3. Ensure the tab is under the metal catch

Replacing the Hydraulic Pump Drive Belt

1. Disengage the PTO and set the parking brake.
2. Stop the engine, remove the key, and wait for all moving parts to stop before leaving the operating position.
3. Remove mower belt. Refer to Replacing the Mower Belt (page 45).
4. Raise the machine and support it with jack stands (Figure 77).

Controls System Maintenance

Adjusting the Control Handle Position

There are 2 height positions for the control levers; high and low. Remove the bolts to adjust the height for the operator.

1. Disengage the PTO, move the motion control levers to the neutral locked position, and set the parking brake.
2. Stop the engine, remove the key, and wait for all moving parts to stop before leaving the operating position.
3. Loosen the bolts and flange nuts installed in the levers (Figure 78).
4. Align the levers front to rear position by bring the levers together to the neutral position and slide them until they are aligned, then tighten the bolts (Figure 79).

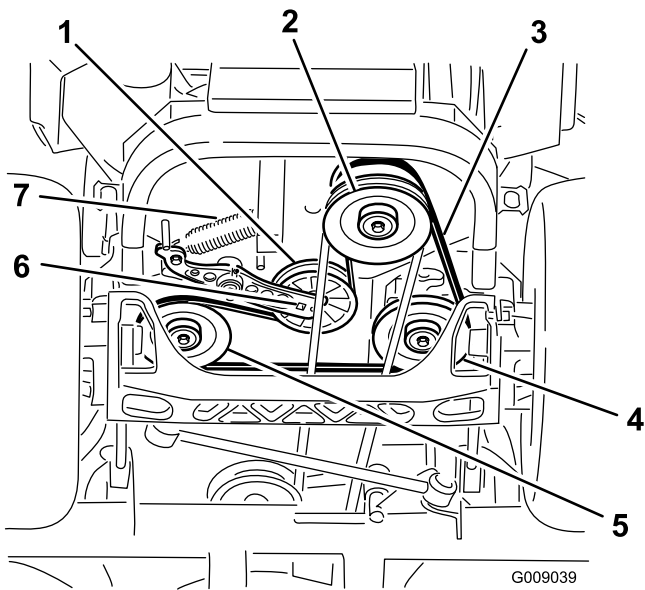

Figure 77

- | | |
|-------------------------------------|------------------------------------|
| 1. Idler pulley | 5. Left hand hydraulic pump pulley |
| 2. Clutch pulley | 6. Square hole in idler arm |
| 3. Pump drive belt | 7. Idler spring |
| 4. Right hand hydraulic pump pulley | |

5. Use a ratchet in the square hole in the idler arm to remove the idler spring (Figure 77).
6. Unhook the idler spring from the frame (Figure 77).
7. Remove the belt from the hydraulic unit drive pulleys and the engine pulley
8. Install the new belt around engine pulley and the 2 drive pulleys.
9. Using a ratchet in the square hole in the idler arm, install the idler spring to the frame (Figure 77).
10. Install the mower belt. Refer to Replacing the Mower Belt (page 45).

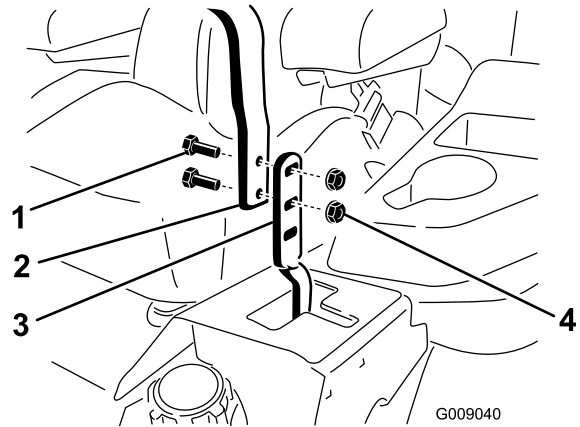

Figure 78

- | | |
|-----------|------------------|
| 1. Bolt | 3. Control lever |
| 2. Handle | 4. Nut |

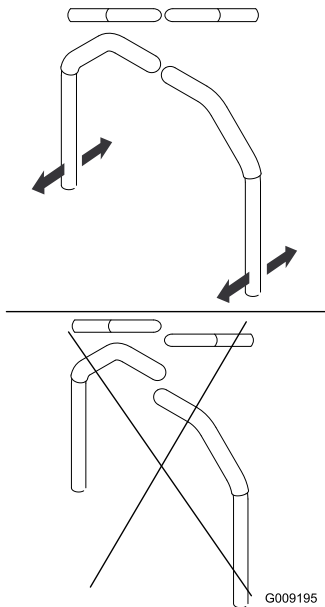

Figure 79

Adjusting the Motion Control Linkage

Located on either side of the fuel tank, below the seat are the pump control linkages. Rotating the pump linkage with a 1/2 inch wrench allows fine-tuning adjustments so that the machine does not move in neutral. Any adjustments should be made for neutral positioning only.

⚠ WARNING

The engine must be running and the drive wheels must be turning so that the motion-control adjustment can be performed. Contact with moving parts or hot surfaces may cause personal injury.

Keep fingers, hands, and clothing clear of rotating components and hot surfaces.

1. Prior to starting the engine, push the deck-lift pedal and remove the height-of-cut pin. Lower the deck to the ground.
2. Raise the rear of machine up and support it with jack stands (or equivalent support) just high enough to allow the drive wheels to turn freely.
3. Remove the electrical connection from the seat safety switch, located under the bottom cushion of the seat.

Note: The switch is a part of the seat assembly.

4. **Temporarily** install a jumper wire across the terminals in the connector of the main wiring harness.
5. Start the engine.

Note: The brake must be engaged and the motion-control levers must be out to start the

engine. The operator does not have to be in the seat because of the jumper wire being used. Run the engine at full throttle and release the brake.

6. Run the machine at least 5 minutes with the motion-control levers at full forward speed to bring the hydraulic oil up to operating temperature.

Note: The motion-control lever needs to be in neutral while making any necessary adjustments.

7. Bring the motion-control levers into the neutral position.
8. Adjust the pump control rod lengths by rotating the double nuts on the rod in the appropriate direction until the wheels slightly creep in reverse (Figure 80).

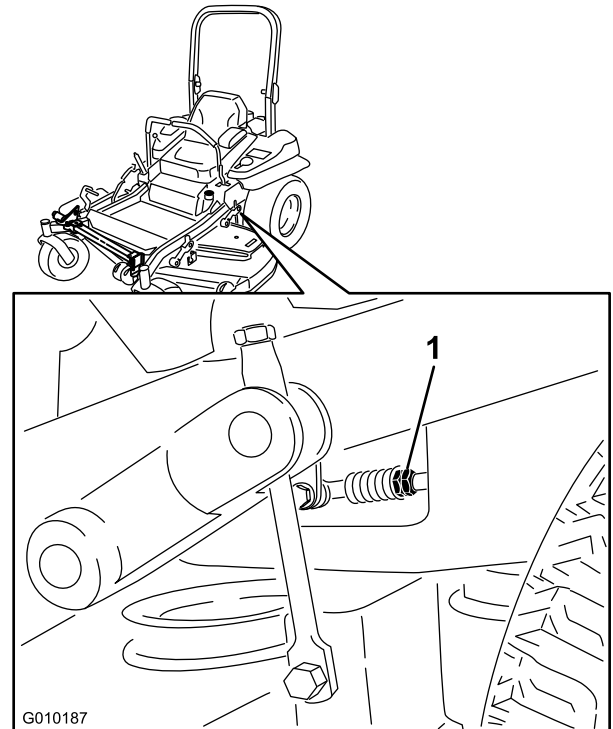

Figure 80

1. Double nuts

9. Move the motion-control levers to the reverse position, and while applying slight pressure to the lever, allow the reverse indicator springs to bring the levers back to neutral.

Note: The wheels must stop turning or slightly creep in reverse.

10. Shut off the machine. Remove the jumper wire from wire harness and plug the connector into the seat switch.
11. Remove the jack stands.
12. Raise the deck and install the height-of-cut pin.
13. Check that the machine does not creep in neutral with the park brakes disengaged.

Adjusting the Motion-control Damper

The top damper-mounting bolt can be adjusted to obtain a more desired motion-control lever resistance. See Figure 81 for mounting options.

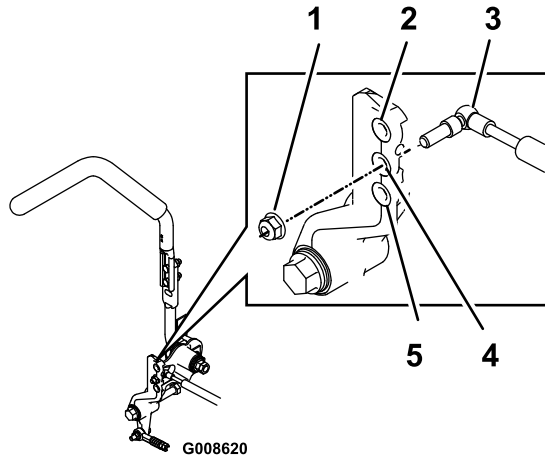

Figure 81

RH Motion Control Shown

1. Torque the lock nut to 23 N-m (17 ft-lb). The bolt must protrude past the end of the locknut after torquing.
2. Most resistance (firmest feel)
3. Damper
4. Medium resistance (medium feel)
5. Least resistance (softest feel)

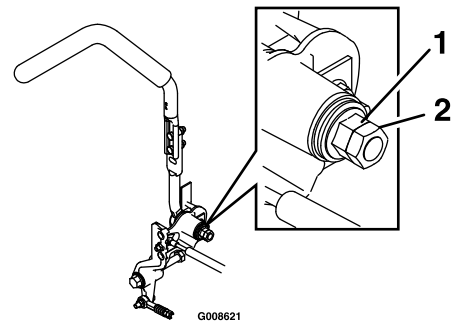

Figure 82

1. Flanged nut
2. Jam nut

Adjusting the Motion Control Neutral Lock Pivot

The flanged nut can be adjusted to obtain a more desired motion control lever resistance when moving it to the neutral lock position. See Figure 82 for adjustment options.

1. Loosen the jam nut.
2. Tighten or loosen the flanged nut to the desired feel.
For more resistance, tighten the flanged nut.
For less resistance, loosen the flanged nut
3. Tighten the jam nut.

Hydraulic System Maintenance

Servicing the Hydraulic System

Hydraulic Oil Type: Toro® HYPR-OIL™ 500 hydraulic oil or Mobil® 1 15W-50.

Important: Use oil specified. Other fluids could cause system damage.

Each Hydraulic System Oil Capacity: 52 ounces (1.5 l) per side with filter change

Checking the Hydraulic Oil

Service Interval: Every 50 hours—Check the hydraulic oil level.

1. Position the machine on a level surface.
2. Disengage the PTO, move the motion-control levers to the neutral-locked position, and set the parking brake.
3. Stop the engine, remove the key, and wait for all moving parts to stop before leaving the operating position.
4. Allow the engine and hydraulic system to cool for 10 minutes.

Note: The oil level on the dipstick will be incorrect if the oil is checked when the machine is hot.

5. Move the seat forward.
6. Clean the area around the dipsticks of the hydraulic system reservoirs (Figure 83).
7. Remove one dipstick from the hydraulic reservoir (Figure 83).
8. Wipe the dipstick off and thread the dipstick into the reservoir.
9. Remove the dipstick and look at the end (Figure 83).

Note: If the oil level is at the add mark, slowly pour only enough oil into the hydraulic reservoir to raise the level to the full or **H** line.

Important: Do not overfill the hydraulic units with oil as damage may occur. Do not run the machine with the oil below the add mark.

10. Install the dipstick.
11. Repeat procedure for the opposite dipstick.

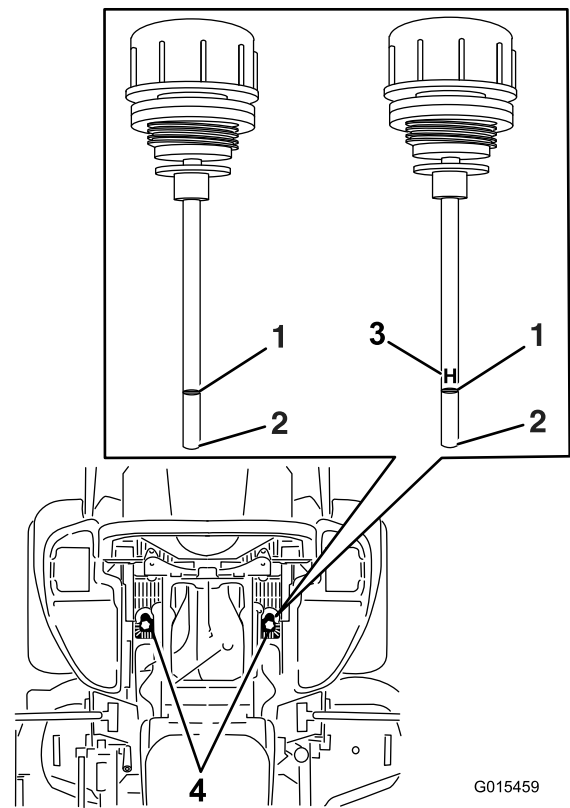

Figure 83

Either dipstick will be used in the machine

1. Full
2. Add
3. **H**—means high level
4. Dipstick locations under seat

G015459

⚠ WARNING

Hydraulic oil escaping under pressure can penetrate skin and cause injury.

- If hydraulic oil is injected into the skin it must be surgically removed within a few hours by a doctor familiar with this type of injury. Gangrene may result if this is not done.
- Keep body and hands away from pin hole leaks or nozzles that eject high pressure hydraulic oil.
- Use cardboard or paper to find hydraulic leaks.
- Safely relieve all pressure in the hydraulic system before performing any work on the hydraulic system.
- Make sure that all hydraulic oil hoses and lines are in good condition and that all hydraulic connections and fittings are tight before applying pressure to the hydraulic system.

Replacing the Hydraulic Filters and Hydraulic Oil

Service Interval: After the first 250 hours—Change the hydraulic filters and hydraulic oil when using any type of oil.

Every 250 hours—Change the hydraulic filters and hydraulic oil when using Mobil® 1 oil (more often in dirty or dusty conditions).

Every 500 hours—Change the hydraulic filters and hydraulic oil when using Toro® HYPR-OIL™ 500 hydraulic oil (more often in dirty or dusty conditions).

To replace the hydraulic oil, the filters need to be removed. Replace both at the same time; refer to Servicing the Hydraulic System (page 50) for the oil specifications.

1. Disengage the blade-control switch (PTO), move the motion-control levers to the neutral-locked position, and set the parking brake.
2. Stop the engine, remove the key, and wait for all moving parts to stop before leaving the operating position.
3. Raise the machine and support it with jack stands (Figure 84).

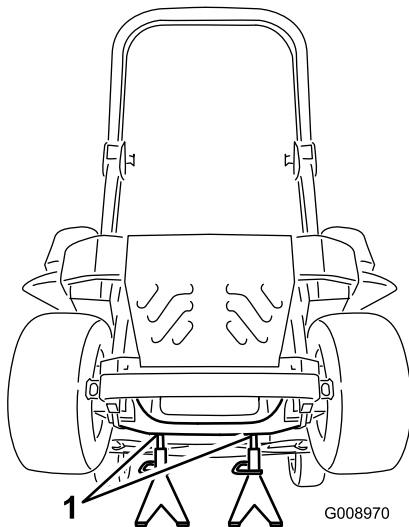

Figure 84

1. Jack stands

4. Remove both the mower belt and the pump-drive belt; refer to Replacing the Mower Belt (page 45) and Replacing the Hydraulic Pump Drive Belt (page 46).

Note: This prevents oil from getting on the belts.

5. Place a drain pan under the filter, remove the old filter, and wipe the surface clean (Figure 85).

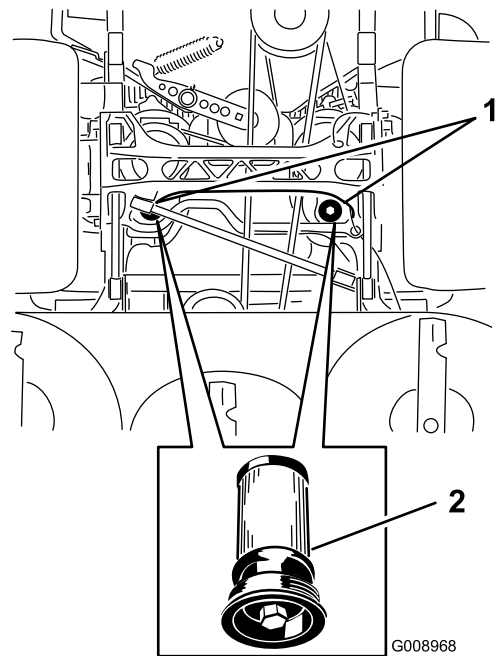

Figure 85

Bottom view of the machine

1. Filter locations
2. Hydraulic filter

6. Apply a thin coat of hydraulic oil to the rubber gasket on the replacement filter (Figure 85).
7. Install the replacement hydraulic filter.
8. Install the pump-drive belt and the mower belt.
9. Remove the jack stands and lower the machine (Figure 84).
10. Add oil to the hydraulic reservoir and check for any leaks.
11. Clean up any spilled oil.
12. Start the engine and let it run for about 2 minutes to purge air from the system.
13. Stop the engine and check for leaks.
14. Check the oil level while the oil is cold.
15. If required, add oil to the hydraulic reservoir.

Note: Do not overfill.

Mower Deck Maintenance

Leveling the Mower Deck

Setting Up the Machine

Note: Ensure the mower deck is leveled before matching the height-of-cut (HOC).

1. Position mower on a flat surface.
2. Disengage the blade control switch (PTO), move the motion control levers to the neutral locked position and set the parking brake.
3. Stop the engine, remove the key, and wait for all moving parts to stop before leaving the operating position.
4. Check tire pressure of the tires. If needed, adjust to 13 psi (90 kPa)
5. Position the mower to the 3 inch (76 mm) height-of-cut position.

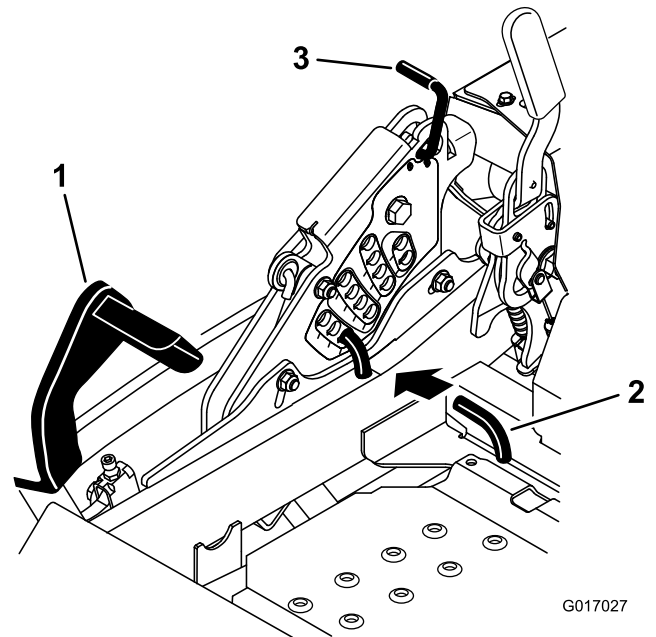

Figure 86

1. Deck lift pedal
2. Height of cut pin
3. Transport lock

Deck Leveling

1. Position the mower on a flat surface.
2. Stop engine, wait for all moving parts to stop, and remove key. Engage parking brake.
3. Check the tire pressure in the drive tires. Proper inflation pressure for tires is 13 psi (90 kPa). Adjust if necessary.
4. Position the transport lock in the latching position.
5. Push the deck lift pedal all the way forward and the deck will latch at the 5 1/2 inch (14 cm) transport position (Figure 86).

6. Insert the height adjustment pin into the 3 inch (7.6 cm) cutting height location.
7. Release the transport lock and allow the deck to lower to the cutting height.
8. Raise the discharge chute.
9. On both sides of the deck, measure from the level surface to the front tip of the blade (Position A). The measurement should read 3 inches (7.6 mm) (Figure 87).

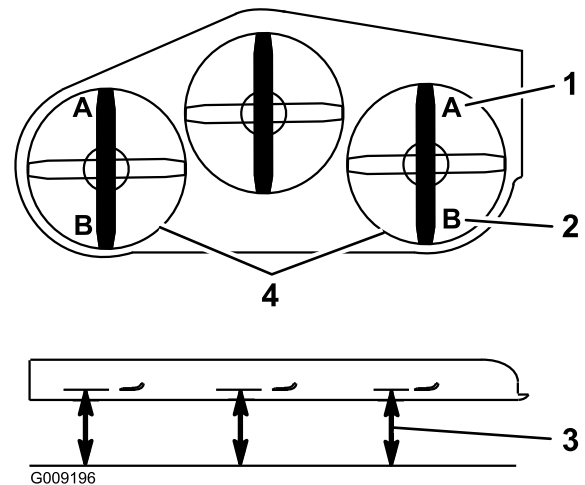

Figure 87

1. 3 inches (7.6 cm) at A is correct
2. 3 1/4 inches (8.3 cm) at B is correct
3. Measure here from the blade tip to hard surface
4. Measure at A and B on both sides

- If needed, loosen the whizlock nut on the side of the yoke and the jam nut on top. Fine tune the screw adjuster by turning it to get 3 inch (7.6 mm) height (see Figure 88).

To increase the height, turn the adjuster screw clockwise; to decrease, turn counterclockwise.

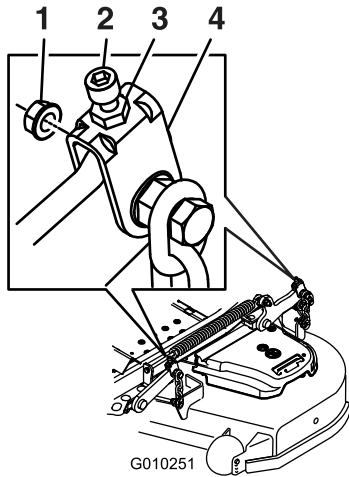

Figure 88

- | | |
|-------------------|------------|
| 1. Whizlock nut | 3. Jam nut |
| 2. Adjuster screw | 4. Yoke |

- If the front deck links do not have enough adjustment to achieve accurate cut height, the single point adjustment can be utilized to gain more adjustment.
- To adjust the single point system, loosen the two bolts at the bottom of the height of cut plate. Refer to Figure 89.

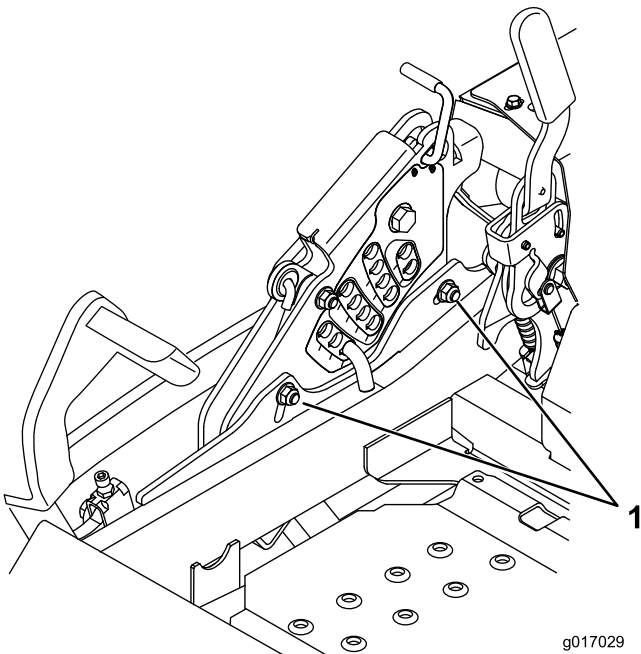

Figure 89

- Bolts at the bottom of the height-of-cut plate

- If the deck is too low, tighten the single point adjustment bolt by rotating it clockwise. If the deck is too high, loosen the single point adjustment bolt by rotating it counterclockwise (Figure 90).

Note: Loosen or tighten the single point adjustment bolt enough to move the height-of-cut plate mounting bolts at least 1/3 the length of the available travel in their slots. This will regain some up and down adjustment on each of the four deck links.

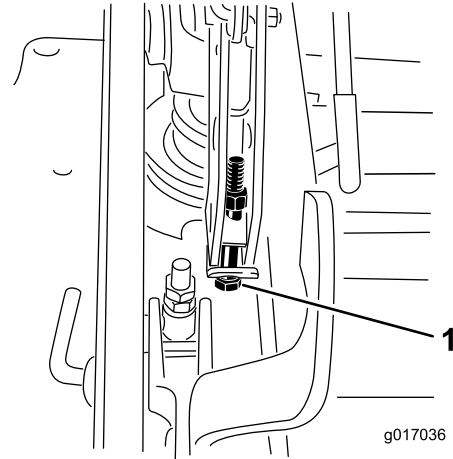

Figure 90

- Single point adjustment bolt

- Tighten the two bolts at the bottom of the height of cut plate (Figure 89). Torque to 27-33 ft-lb (37-45 N-m).

Note: In most conditions, the back blade tip should be adjusted 1/4 inch (6.4 mm) higher than the front.

- On both sides of the deck, measure from the level surface to the back tip of the blade (Position B). The measurement should read 3 1/4 inches (8.3 cm) (Figure 87).
- Fine tune the screw adjuster by turning it to get 3-1/4 inches (8.3 mm) height (Figure 88).
To increase the height, turn the adjustment nut clockwise; to decrease, turn counterclockwise.
- Measure until all four sides are the correct height. Tighten all the nuts on the deck lift arm assemblies.
- Lower discharge chute.

Servicing the Cutting Blades

Maintain sharp blades throughout the cutting season because sharp blades cut cleanly without tearing or shredding the grass blades. Tearing and shredding turns grass brown at the edges, which slows growth and increases the chance of disease.

Check the cutter blades daily for sharpness, and for any wear or damage. File down any nicks and sharpen the blades as necessary. If a blade is damaged or worn, replace it immediately with a genuine Toro replacement blade. For

convenient sharpening and replacement, you may want to keep extra blades on hand.

⚠ DANGER

A worn or damaged blade can break, and a piece of the blade could be thrown into the operator's or bystander's area, resulting in serious personal injury or death.

- Inspect the blade periodically for wear or damage.
- Replace a worn or damaged blade.

Before Inspecting or Servicing the Blades

Park the machine on a level surface, disengage the blade control switch (PTO), and set the parking brake. Turn the ignition key to Off. Remove the key.

Inspecting the Blades

Service Interval: Before each use or daily

1. Inspect the cutting edges (Figure 91). If the edges are not sharp or have nicks, remove and sharpen the blades. Refer to (page).
2. Inspect the blades, especially the curved area (Figure 91). If you notice any damage, wear, or a slot forming in this area (Figure 91), immediately install a new blade.

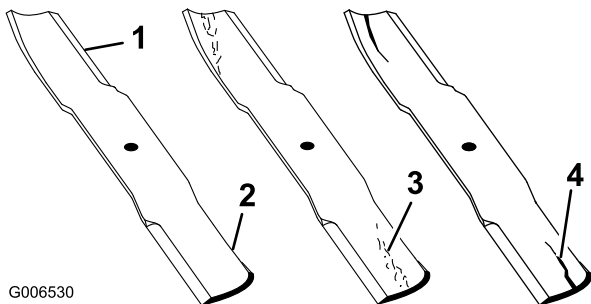
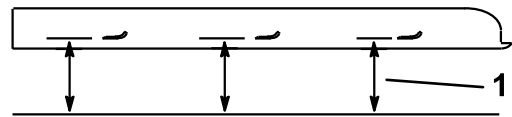
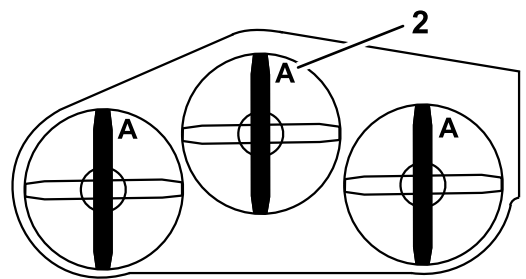

Figure 91

- | | |
|-----------------|----------------------|
| 1. Cutting Edge | 3. Wear/slot Forming |
| 2. Curved Area | 4. Crack |



G000975

Figure 92

1. Measure here from blade
2. Position A to hard surface

4. Rotate the opposite ends of the blades forward.
5. Measure from a level surface to the cutting edge of the blades at the same position as in step 3 above. The difference between the dimensions obtained in steps 3 and 4 must not exceed 1/8 inch (3 mm). If this dimension exceeds 1/8 inch (3 mm), the blade is bent and must be replaced; refer to Removing the Blades and Installing the Blades.

⚠ WARNING

A blade that is bent or damaged could break apart and could seriously injure or kill you or bystanders.

- Always replace bent or damaged blade with a new blade.
- Never file or create sharp notches in the edges or surfaces of blade.

Checking for Bent Blades

1. Disengage the blade control switch (PTO), move the motion control levers to the neutral locked position and set the parking brake.
2. Stop the engine, remove the key, and wait for all moving parts to stop before leaving the operating position.
3. Rotate the blades until the ends face forward and backward (Figure 92). Measure from a level surface to the cutting edge, position A, of the blades (Figure 92). Note this dimension.

Removing the Blades

Blades must be replaced if a solid object is hit, if the blade is out of balance or is bent. To ensure optimum performance and continued safety conformance of the machine, use genuine Toro replacement blades. Replacement blades made by other manufacturers may result in non-conformance with safety standards.

1. Hold the blade end using a rag or thickly-padded glove.
2. Remove the blade bolt, curved washer, and blade from the spindle shaft (Figure 93).

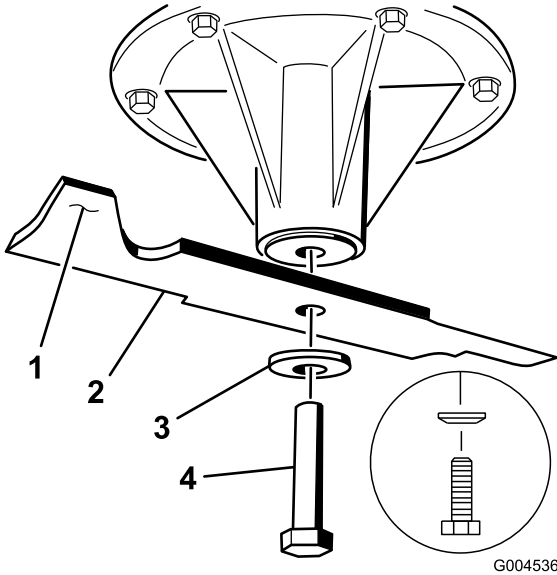

Figure 93

- | | |
|-----------------------|------------------|
| 1. Sail Area of Blade | 3. Curved washer |
| 2. Blade | 4. Blade Bolt |

Sharpening the Blades

⚠ WARNING

When sharpening blade, pieces of blade could be thrown and cause serious injury.

Wear proper eye protection when sharpening blade.

1. Use a file to sharpen the cutting edge at both ends of the blade (Figure 94). Maintain the original angle. The blade retains its balance if the same amount of material is removed from both cutting edges.

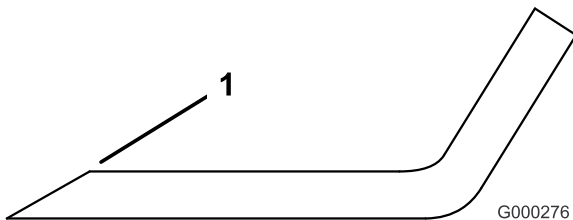

Figure 94

1. Sharpen at original angle

2. Check the balance of the blade by putting it on a blade balancer (Figure 95). If the blade stays in a horizontal position, the blade is balanced and can be used. If the blade is not balanced, file some metal off the end of the sail area only (Figure 96). Repeat this procedure until the blade is balanced.

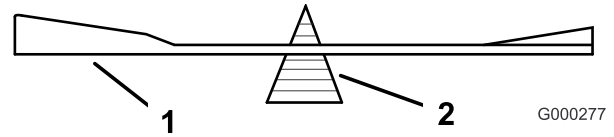

Figure 95

1. Blade
2. Balancer

Installing the Blades

1. Install the blade onto the spindle shaft (Figure 96).

Important: The curved part of the blade must be pointing upward toward the inside of the mower to ensure proper cutting.

2. Install the spring disk and blade bolt. The spring disk cone must be installed toward the bolt head (Figure 96). Torque the blade bolt to 85-110 ft-lb (115-150 N-m).

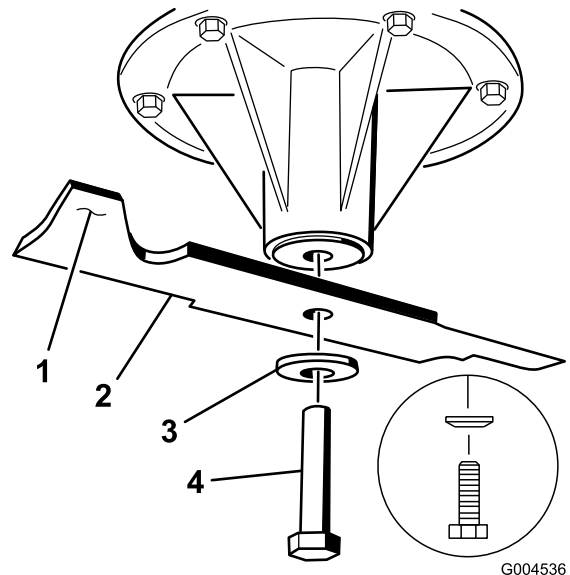

Figure 96

- | | |
|-----------------------|---------------------------|
| 1. Sail Area of Blade | 4. Blade Bolt |
| 2. Blade | 5. Cone Towards Bolt Head |
| 3. Spring Disk | |

Removing the Mower Deck

Lock out the spring loaded deck arms before servicing or removing the mower deck.

⚠ WARNING

Deck lift arm assemblies have stored energy. Removing the deck with out releasing the stored energy can cause serious injury or death.

Do not attempt to disassemble the deck from the front frame without locking out the stored energy.

1. Stop the engine, wait for all of the moving parts to stop, remove the key, and engage parking brake.
2. Remove the height adjustment pin and lower the deck to the ground.
3. Place the height adjustment pin in the 7.6 cm (3 inch) cutting height location.

Note: This locks the deck lift arms in the lowest position when the deck is removed and the stored energy in the deck spring is released.

4. Remove the belt covers.
5. Lift up the floor pan and insert a ratchet into the square hole in the deck idler (Figure 97).
6. Rotate the deck idler clockwise and remove the mower belt (Figure 97).

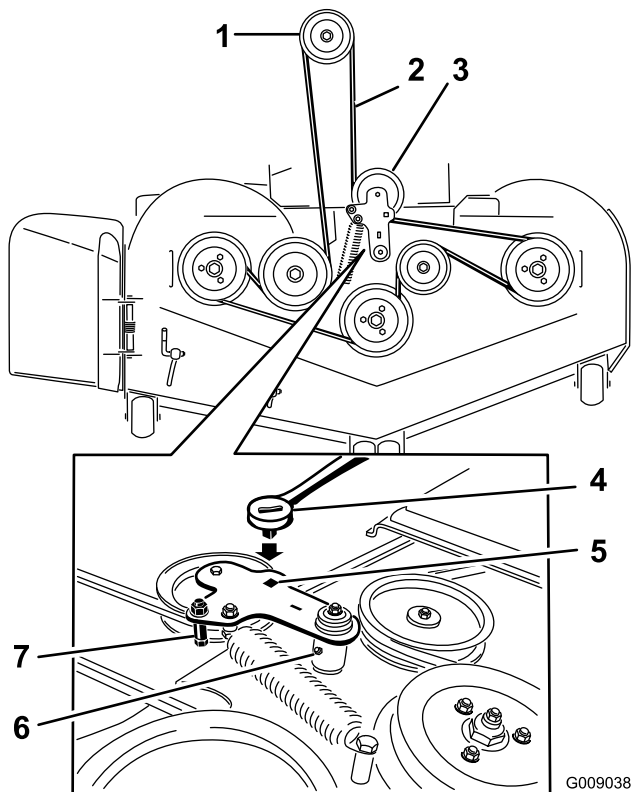

Figure 97

1. Clutch pulley
2. Mower belt
3. Spring loaded idler pulley
4. Ratchet
5. Square hole in the idler arm for the ratchet
6. Idler grease fitting
7. Belt guide

7. Remove and retain the hardware on both sides of the deck as shown in Figure 98.

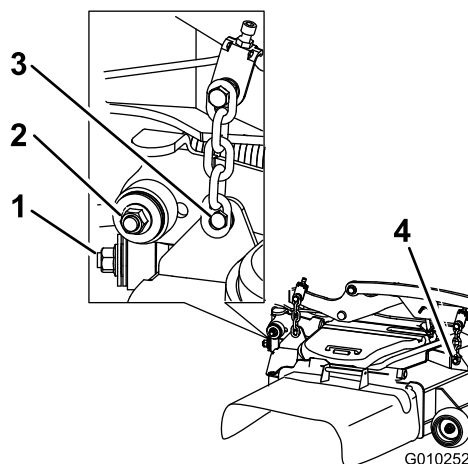

Figure 98

1. Right stabilizer
 2. Deck strut (right side shown)
 3. Remove the rear deck lift attachment shoulder bolt and nut.
 4. Remove the front deck lift attachment shoulder bolt and nut.
-
8. Raise the deck struts and secure them in the up position.
 9. Slide the deck out to the right side of the machine.

Replacing the Grass Deflector

⚠ WARNING

An uncovered discharge opening could allow the lawn mower to throw objects in the operator's or bystander's direction and result in serious injury. Also, contact with the blade could occur.

Never operate the lawn mower unless you install a cover plate, a mulch plate, grass deflector, or bagger.

1. Remove the locknut, bolt, spring, and spacer holding the deflector to the pivot brackets (Figure 99).

Cleaning

Cleaning Under the Mower

Service Interval: Before each use or daily

1. Disengage the blade control switch (PTO), move the motion control levers to the neutral locked position, and set the parking brake.
2. Stop the engine, remove the key, and wait for all moving parts to stop before leaving the operating position.
3. Raise the mower to the transport position.

Waste Disposal

Engine oil, batteries, hydraulic oil, and engine coolant are pollutants to the environment. Dispose of these according to your state and local regulations.

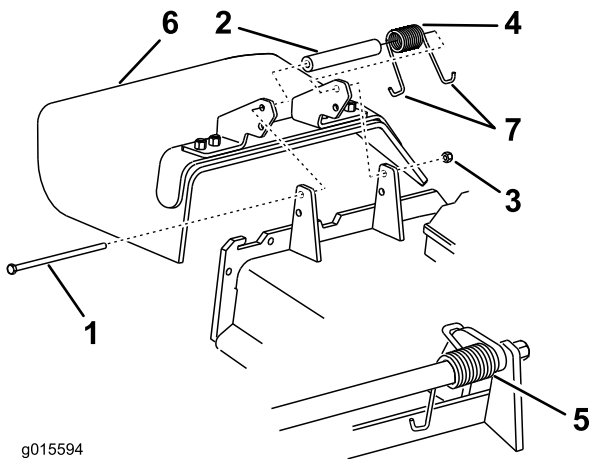

Figure 99

- | | |
|------------|-------------------------|
| 1. Bolt | 5. Spring installed |
| 2. Spacer | 6. Grass deflector |
| 3. Locknut | 7. J hook end of spring |
| 4. Spring | |

2. Remove damaged or worn grass deflector.
3. Place spacer and spring onto the grass deflector. Place one **J** end of spring behind deck edge.

Note: Make sure that one **J** end of spring is installed behind deck edge before installing the bolt as shown in Figure 99.

4. Install the bolt and nut.
5. Place one **J** hook end of spring around grass deflector (Figure 99).

Important: The grass deflector must be able to rotate. Lift the deflector up to the full open position and ensure that it rotates into the full down position.

Storage

Cleaning and Storage

1. Disengage the power take off (blade control switch (PTO), set the parking brake, and turn the ignition key to the off position. Remove the key.
2. Remove grass clippings, dirt, and grime from the external parts of the entire machine, especially the engine and hydraulic system. Clean dirt and chaff from the outside of the engine cylinder head fins and blower housing.

Important: You can wash the machine with mild detergent and water. Do not pressure wash the machine. Avoid excessive use of water, especially near the control panel, engine, hydraulic pumps, and motors.

3. Check the brake; refer to Brake Maintenance (page 44).
4. Service the air cleaner; refer to Servicing the Air Cleaner (page 30).
5. Grease the machine; refer to Lubricating the Machine (page 28).
6. Change the crankcase oil; refer to Changing the Engine Oil (page 32).
7. Check the tire pressure; refer to Checking the Tire Pressure (page 40).
8. Change the hydraulic filters; refer to Servicing the Hydraulic System (page 50).
9. Charge the battery; refer to Servicing the Battery (page 37).
10. Scrape any heavy buildup of grass and dirt from the underside of the mower, then wash the mower with a garden hose.

Note: Run the machine with the blade control switch (PTO) engaged and the engine at high idle for 2 to 5 minutes after washing.

11. Check the condition of the blades; refer to (page).
12. Prepare the machine for storage when non-use occurs over 30 days. Prepare the machine for storage as follows:
 - A. Add a petroleum based stabilizer/conditioner to fuel in the tank. Follow mixing instructions from the stabilizer manufacturer. Do not use an alcohol based stabilizer (ethanol or methanol).

Note: A fuel stabilizer/conditioner is most effective when mixed with fresh fuel and used at all times.
 - B. Run the engine to distribute conditioned fuel through the fuel system (5 minutes).
 - C. Stop the engine, allow it to cool, and drain the fuel tank; refer to Servicing the Fuel Tank (page 36) in the Maintenance Section.

- D. Restart the engine and run it until it stops.
- E. Dispose of fuel properly. Recycle as per local codes.

Important: Do not store stabilizer/conditioned fuel over 90 days.

13. Check and tighten all bolts, nuts, and screws. Repair or replace any part that is damaged.
14. Paint all scratched or bare metal surfaces. Paint is available from your Authorized Service Dealer.
15. Store the machine in a clean, dry garage or storage area. Remove the key from the ignition switch and keep it out of reach of children or other unauthorized users. Cover the machine to protect it and keep it clean.

Troubleshooting

Problem	Possible Cause	Corrective Action
The malfunction Indicator Light (MIL) comes on.	<ol style="list-style-type: none"> 1. The engine is too hot. 2. There is old gas in the gas tank. 3. The fuel shut-off valve is not open completely. 4. The air cleaner is dirty. 5. The battery is not charged. 6. Incorrect fuel filters are being used or the fuel filters are dirty. 7. The connections to the sensors electronic control unit (ECU) and fuel injectors are not secured properly. 8. There is low voltage from the battery. 9. A fuse is blown. 	<ol style="list-style-type: none"> 1. Turn the engine off and let it cool. 2. Use new gas. 3. Open the fuel shut-off valve. 4. Make sure that the air cleaner and precleaner are clean. Replace if necessary. 5. Charge or replace the battery. 6. Contact an Authorized Service Dealer. 7. Contact an Authorized Service Dealer. 8. Ensure a good 12 volt battery is being used and is fully charged. 9. Check and replace any blown fuses.
The starter does not crank.	<ol style="list-style-type: none"> 1. The blade control switch (PTO) is engaged. 2. The parking brake is not on. 3. The drive levers are not in neutral lock position. 4. The operator is not seated. 5. The battery is dead. 6. The electrical connections are corroded or loose. 7. The fuse is blown. 8. The relay or switch is defective. 	<ol style="list-style-type: none"> 1. Move the blade control switch (PTO) to disengaged. 2. Set the parking brake. 3. Ensure that the drive levers are in the neutral lock position. 4. Sit on the seat. 5. Charge the battery. 6. Check the electrical connections for good contact. 7. Replace the fuse. 8. Contact an Authorized Service Dealer.
The engine will not start, starts hard, or fails to keep running	<ol style="list-style-type: none"> 1. The fuel tank is empty. 2. The fuel shutoff valve is closed. 3. The oil level in the crankcase is low. 4. The throttle and choke are not in the correct position. 5. There is dirt in fuel filter. 6. There is dirt, water, or stale fuel is in the fuel system. 7. The air cleaner is dirty. 8. The seat switch is not functioning properly. 9. The electrical connections are corroded, loose or faulty. 10. The relay or switch is defective. 11. The spark plug is faulty. 12. The spark plug wire is not connected. 	<ol style="list-style-type: none"> 1. Fill the fuel tank. 2. Open the fuel shutoff valve. 3. Add oil to the crankcase. 4. Be sure that the throttle control is midway between the "SLOW" and "FAST" positions. 5. Replace the fuel filter. 6. Contact an Authorized Service Dealer. 7. Clean or replace the air cleaner element. 8. Check the seat switch indicator. Replace the seat if needed. 9. Check the electrical connections for good contact. Clean the connector terminals thoroughly with electrical contact cleaner, apply dielectric grease, and reconnect. 10. Contact an Authorized Service Dealer. 11. Clean, adjust, or replace spark plug. 12. Check the spark plug wire connection.

Problem	Possible Cause	Corrective Action
The engine loses power.	<ol style="list-style-type: none"> 1. The engine load is excessive. 2. The air cleaner is dirty. 3. The oil level in the crankcase is low. 4. The cooling fins and air passages above the engine are plugged. 5. The vent hole in the fuel cap is plugged. 6. There is dirt in the fuel filter. 7. There is dirt, water, or stale fuel in the fuel system. 	<ol style="list-style-type: none"> 1. Reduce the ground speed. 2. Clean the air cleaner element. 3. Add oil to the crankcase. 4. Remove the obstruction from the cooling fins and air passages. 5. Clean or replace the fuel cap. 6. Replace the fuel filter. 7. Contact an Authorized Service Dealer.
The engine overheats.	<ol style="list-style-type: none"> 1. The engine load is excessive. 2. The oil level in the crankcase is low. 3. The cooling fins and air passages above the engine are plugged. 	<ol style="list-style-type: none"> 1. Reduce the ground speed. 2. Add oil to the crankcase. 3. Remove the obstruction from the cooling fins and air passages.
The mower pulls left or right (with levers fully forward)	<ol style="list-style-type: none"> 1. The tracking needs adjustment 2. The tire pressure in drive tires not correct. 	<ol style="list-style-type: none"> 1. Adjust the tracking. 2. Adjust tire pressure in the drive tires.
The machine does not drive.	<ol style="list-style-type: none"> 1. The by pass valves is not closed tight. 2. The pump belt is worn, loose or broken. 3. The pump belt is off a pulley. 4. The idler sprint is broken or missing. 5. The hydraulic oil level is low or too hot. 	<ol style="list-style-type: none"> 1. Tighten the by pass valves. 2. Change the belt. 3. Change the belt. 4. Replace the spring. 5. Add hydraulic oil to reservoirs or let it cool down.
There is abnormal vibration.	<ol style="list-style-type: none"> 1. The cutting blade(s) is/are bent or unbalanced. 2. The blade mounting bolt is loose. 3. The engine mounting bolts are loose. 4. The engine pulley, idler pulley, or blade pulley is loose. 5. The engine pulley is damaged. 6. The blade spindle is bent. 7. The motor mount is loose or worn. 	<ol style="list-style-type: none"> 1. Install new cutting blade(s). 2. Tighten the blade mounting bolt. 3. Tighten the engine mounting bolts. 4. Tighten the appropriate pulley. 5. Contact an Authorized Service Dealer. 6. Contact an Authorized Service Dealer. 7. Contact an Authorized Service Dealer.
Mowing is resulting in uneven cutting height.	<ol style="list-style-type: none"> 1. The blade(s) not sharp. 2. The cutting blade(s) is/are bent. 3. The mower deck is not level. 4. The underside of mower is dirty. 5. The tire pressure is not correct. 6. The blade spindle bent. 	<ol style="list-style-type: none"> 1. Sharpen the blade(s). 2. Install new cutting blade(s). 3. Level the mower deck from side-to-side and front-to-rear. 4. Clean the underside of the mower. 5. Adjust the tire pressure. 6. Contact an Authorized Service Dealer.
The blades do not rotate.	<ol style="list-style-type: none"> 1. The mower deck belt is worn, loose or broken. 2. The mower deck belt is off pulley. 3. The pump drive belt is worn, loose or broken. 4. The idler spring is broken or missing. 	<ol style="list-style-type: none"> 1. Install a new deck belt. 2. Install the mower deck pulley and check the idler pulley, idler arm, and spring for correct position and function. 3. Check the belt tension or install a new belt. 4. Replace the spring.

Problem	Possible Cause	Corrective Action
The clutch will not engage.	<ol style="list-style-type: none"> 1. The fuse is blown. 2. There is low voltage supply at the clutch. 3. The coil is damaged. 4. There is inadequate current supply. 5. The rotor/armature airgap is too large. 	<ol style="list-style-type: none"> 1. Replace the fuse. Check coil resistance, battery charge, charging system, and wiring connections and replace if necessary. 2. Check coil resistance, battery charge, charging system, and wiring connections and replace if necessary. 3. Replace the clutch. 4. Repair or replace the clutch lead wire or electrical system. Clean the connector contacts. 5. Remove the shim or replace the clutch.

Schematics

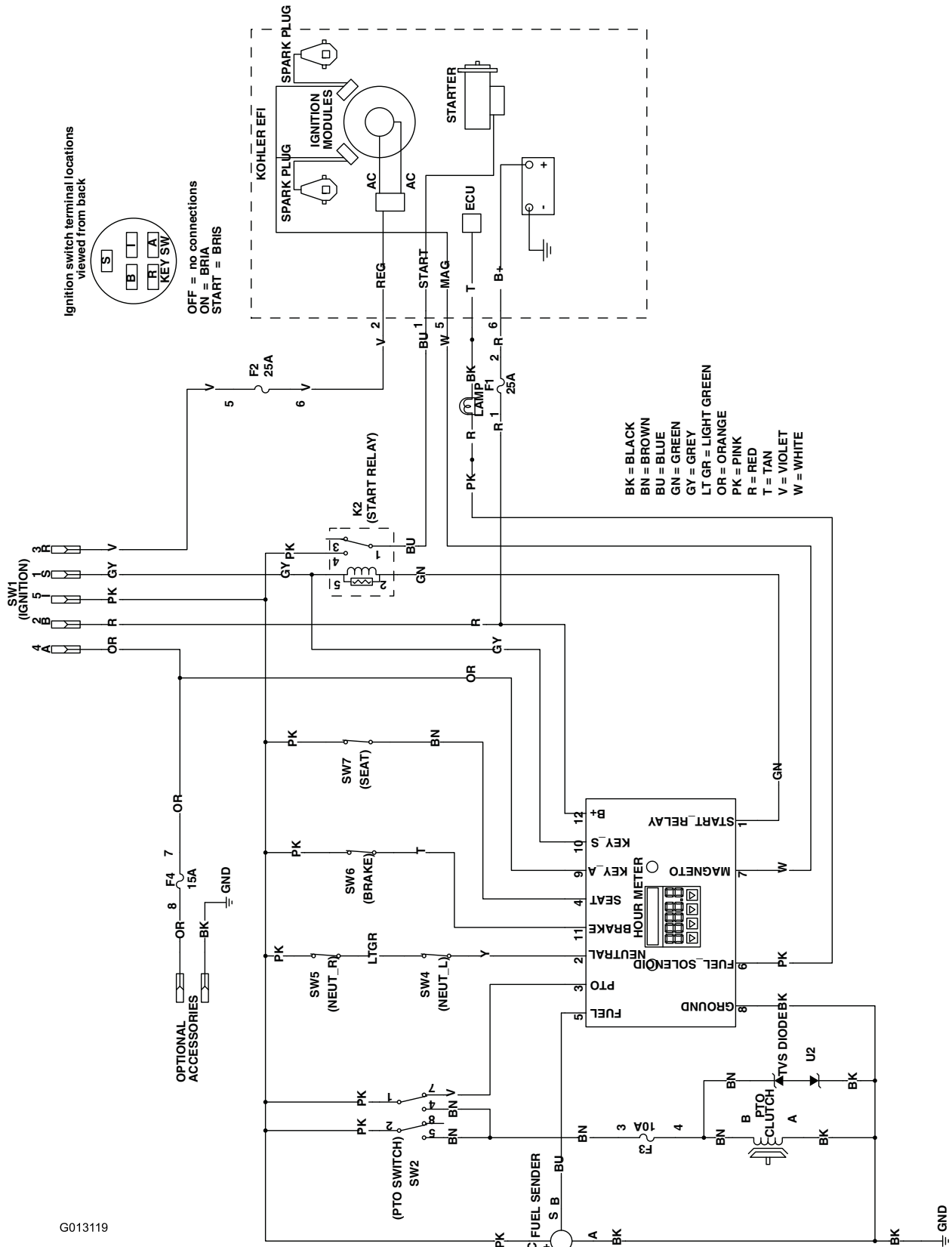

G013119

Notes:



The Toro Total Coverage Warranty

A Limited Warranty (see warranty periods below)

Landscape Contractor Equipment (LCE)

Conditions and Products Covered

The Toro Company and its affiliate, Toro Warranty Company, pursuant to an agreement between them, jointly promise to the original purchaser to repair the Toro Products listed below if defective in materials or workmanship.

The following time periods apply from the date of purchase by the original owner:

Products	Warranty Period
21 in. Mowers	2 years Residential Use ¹ 1 year Commercial Use
• Engines ⁴	Honda – 2 years Kawasaki – 3 years
30 in. Mowers	2 years Residential Use ¹ 1 year Commercial Use
• Engines ⁴	Kawasaki – 3 years
Mid-Size Walk-Behind Mowers	2 years
• Engines ⁴	Kawasaki – 3 years
Grand Stand® Mowers	5 years or 1,200 hours ² 3 years
• Engines ⁴	3 years
• Frame	Lifetime (original owner only) ³
Z Master® 2000 Series Mowers	4 years or 500 hours ² 3 years
• Engines ⁴	3 years
• Frame	Lifetime (original owner only) ³
Z Master® 3000 Series Mowers	5 years or 1,200 hours ² 3 years
• Engines ⁴	3 years
• Frame	Lifetime (original owner only) ³
Z Master® 5000 Series Mowers	5 years or 1,200 hours ² Kohler Command – 2 years Kohler EFI – 3 years
• Engines ⁴	Kohler Command – 2 years Kohler EFI – 3 years
• Frame	Lifetime (original owner only) ³
Z Master® 6000 Series Mowers	5 years or 1,200 hours ² Kawasaki – 3 years
• Engines ⁴	Kawasaki – 3 years
• Frame	Lifetime (original owner only) ³
Z Master®7000 Series Mowers	5 years or 1,200 hours ² 2 years
• Engines ⁴	2 years
• Frame	Lifetime (original owner only) ³
All Mowers	
• Battery	90 days Parts and Labor 1 year Parts only
• Belts and Tires	90 days
• Attachments	1 year

¹Residential use means use of the product on the same lot as your home. Use at more than one location is considered commercial use and the commercial warranty would apply.

²Whichever occurs first.

³Lifetime Frame Warranty - If the main frame, consisting of the parts welded together to form the tractor structure that other components such as the engine are secured to, cracks or breaks in normal use, it will be repaired or replaced, at Toro's option, under warranty at no cost for parts and labor. Frame failure due to misuse or abuse and failure or repair required due to rust or corrosion are not covered.

⁴Some engines used on Toro Products are warranted by the engine manufacturer.

Instructions for Obtaining Warranty Service

If you think that your Toro Product contains a defect in materials or workmanship, follow this procedure:

1. Contact any Authorized Toro Service Dealer to arrange service at their dealership. To locate a dealer convenient to you, refer to the Yellow Pages of your telephone directory (look under "Lawn Mowers") or access our web site at www.Toro.com. You may also call the numbers listed in item #3 to use the 24-hour Toro Dealer locator system.
2. Bring the product and your proof of purchase (sales receipt) to the Service Dealer. The dealer will diagnose the problem and determine if it is covered under warranty.
3. If for any reason you are dissatisfied with the Service Dealer's analysis or with the assistance provided, contact us at:

RLC Customer Care Department
Toro Warranty Company
8111 Lyndale Avenue South
Bloomington, MN 55420-1196
888-865-5676 (U.S. Customers)
888-865-5691 (Canada customers)

Owner Responsibilities

You must maintain your Toro Product by following the maintenance procedures described in the *Operator's Manual*. Such routine maintenance, whether performed by a dealer or by you, is at your expense.

Items and Conditions Not Covered

There is no other express warranty except for special emission system coverage and engine warranty coverage on some products. This express warranty does not cover the following:

- Cost of regular maintenance service or parts, such as filters, fuel, lubricants, oil changes, spark plugs, air filters blade sharpening or worn blades, cable/linkage adjustments, or brake and clutch adjustments
- Components failing due to normal wear
- Any product or part which has been altered or misused or neglected and requires replacement or repair due to accidents or lack of proper maintenance
- Pickup and delivery charges
- Repairs or attempted repairs by anyone other than an Authorized Toro Service Dealer
- Repairs necessary due to failure to follow recommended fuel procedure (consult *Operator's Manual* for more details)
 - Removing contaminants from the fuel system is not covered
 - Use of old fuel (more than one month old) or fuel which contains more than 10% ethanol or more than 15% MTBE
 - Failure to drain the fuel system prior to any period of non-use over one month

General Conditions

All repairs covered by these warranties must be performed by an Authorized Toro Service Dealer using Toro approved replacement parts.

Neither The Toro Company nor Toro Warranty Company is liable for indirect, incidental or consequential damages in connection with the use of the Toro Products covered by this warranty, including any cost or expense of providing substitute equipment or service during reasonable periods of malfunction or non-use pending completion of repairs under this warranty.

All implied warranties of merchantability (that the product is fit for ordinary use) and fitness for use (that the product is fit for a particular purpose) are limited to the duration of the express warranty.

Some states do not allow exclusions of incidental or consequential damages, or limitations on how long an implied warranty lasts, so the above exclusions and limitations may not apply to you.

This warranty gives you specific legal rights, and you may also have other rights which vary from state to state.

Countries Other than the United States or Canada

Customers who have purchased Toro products outside the United States or Canada should contact their Toro Distributor (Dealer) to obtain guarantee policies for your country, province, or state. If for any reason you are dissatisfied with your Distributor's service or have difficulty obtaining guarantee information, contact the Toro importer. If all other remedies fail, you may contact us at Toro Warranty Company.