



MODEL NO. 52-1580

INSTALLATION
INSTRUCTIONSTWO CYCLE ENGINE REPLACEMENT
(Snapper 21500 PC)**REMOVE EXISTING ENGINE**

1. Disconnect spark plug wire from engine and drain fuel and oil.
2. Disconnect throttle cable from engine.
3. Disconnect bag adapter interlock wire from engine.
4. Remove blade and blade retainer from engine crankshaft.
5. Remove engine mounting bolts. Remove belt from crankshaft pulley and lift engine off mower housing.

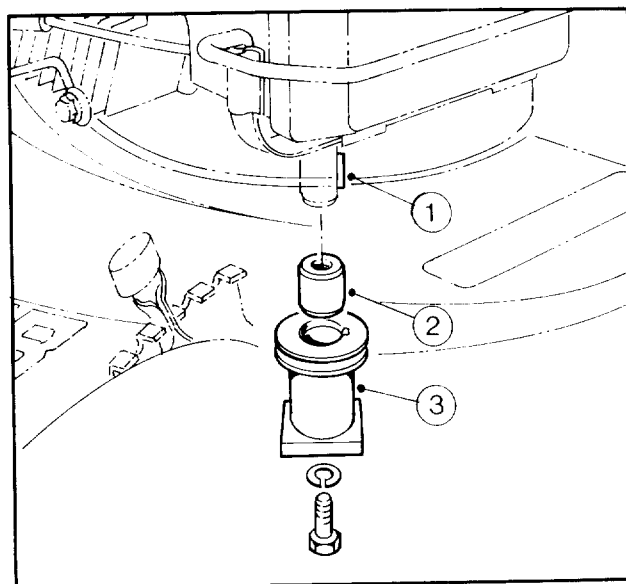

Figure 1

MOUNT NEW ENGINE

1. Drill engine mounting holes in mower housing out to 25/64" dia.

Note: Before drilling, position engine on mower housing, with spark plug forward, to determine which holes must be drilled.

2. Loosely secure key, pulley spacer and blade retainer to engine crankshaft (Fig. 1). Do not install blade at this time.
3. Position engine onto mower housing and route belt around pulley, before installing engine mounting bolts.
4. Install engine mounting bolts as follows:

- a. Right front mounting hole - use 3/8-16 x .75" lg. capscrew and 3/8-16 locknut with red insert. Torque to 240-320 in-lb.

1. Key
2. Pulley Spacer
3. Blade Retainer

- b. Left front mounting hole - use 3/8-16 x .50" lg. capscrew. Nut not required. Torque to 160-210 in-lb.
- c. Right rear mounting hole - use 3/8-16 x .75" lg. capscrew and 3/8-16 jam nut. Torque capscrew to 160-210 in-lb before tightening jam nut.

Note: Torque after all capscrews are installed.

INSTALL THROTTLE CONTROL

1. Move throttle control to FAST position.
2. Hook cable end to governor spring lever and position cable casing under cable clamp (Fig. 2).

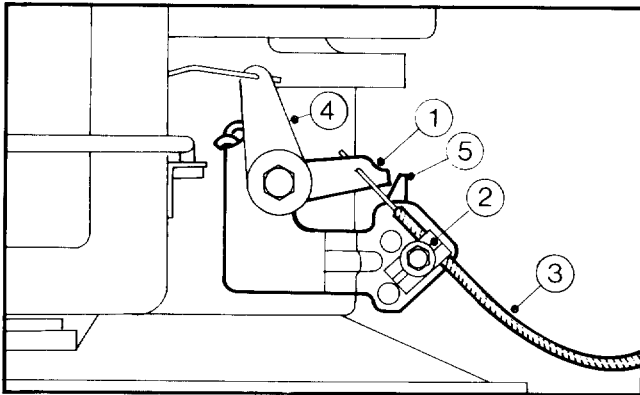

Figure 2

1. Governor Spring Lever
2. Cable Clamp
3. Cable Casing
4. Choke Lever
5. Engine Ground Strap

3. Slide cable until control arm contacts choke lever and begins to close carburetor choke butterfly (Fig. 2).

4. Tighten cable clamp and make sure choke is completely open when throttle is in FAST position, and lever contacts engine ground strap when in the STOP position.

CONNECT WIRING ASSEMBLY

1. Remove ignition coil wire from throttle-stop terminal. Use screwdriver to press in locking tab on terminal, if needed (Fig. 3).

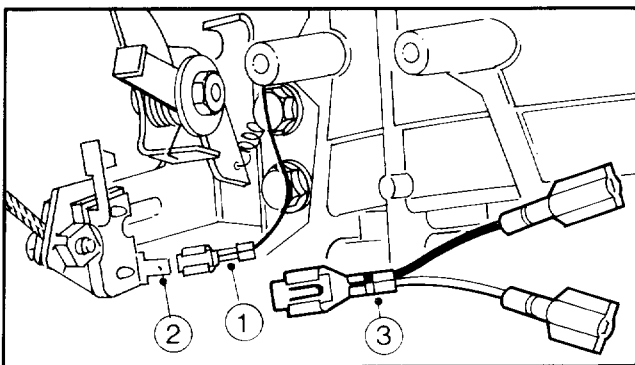

Figure 3

1. Ignition Coil Wire
2. Throttle-Stop Terminal
3. Wiring Assembly

2. Connect female terminal of wiring assembly to throttle-stop terminal. Make sure terminals are positioned as shown in Fig. 3 and locked firmly together.

3. Cut interlock wire to length required to reach one of the male terminals of wiring assembly. Make sure interlock wire does not interfere with drive system operation, (Fig. 4).

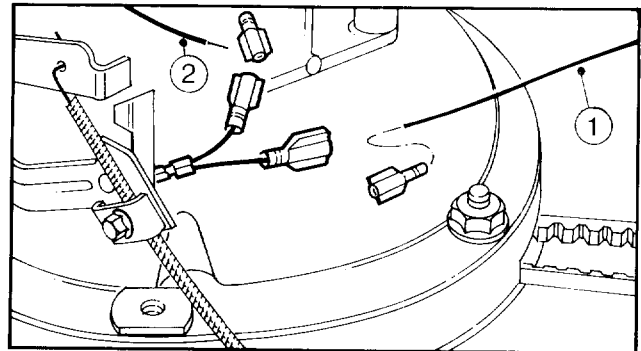

Figure 4

1. Interlock Wire
2. Ignition Coil Wire

4. Strip off approximately 1/4" of insulation from interlock wire and firmly secure female terminal to wire. Connect interlock wire to wiring assembly, (Fig. 4).

5. Cut female terminal off ignition coil wire (Fig. 4). Strip off approximately 1/4" of insulation and firmly secure new female terminal. Connect ignition coil wire to wiring assembly.

6. Check all connections to make sure they are firmly secured.

MOUNT BLADE

Note: Before blade can be installed, mounting hole must be enlarged.

1. Mount blade securely in a immovable drill press fixture.

2. Drill blade mounting hole out to 7/16" dia., using a high quality, "high speed" or tungsten carbide drill bit. Set drill press to slowest RPM and use a liberal amount of cutting oil when drilling.

3. Remove blade bolt, securing blade retainer, pulley spacer, and key to crankshaft. Install blade and secure to crankshaft with lockwasher and blade bolt. Torque to 45-60 ft-lb.

MOUNT GAS TANK

Note: Use the following instructions to mount gas tank. Instructions included with tank kit are not for this application. Bottom tank mount included with fuel tank kit is also not used for this application.

1. Thread fuel valve into fuel tank, positioning as shown in Fig. 5.

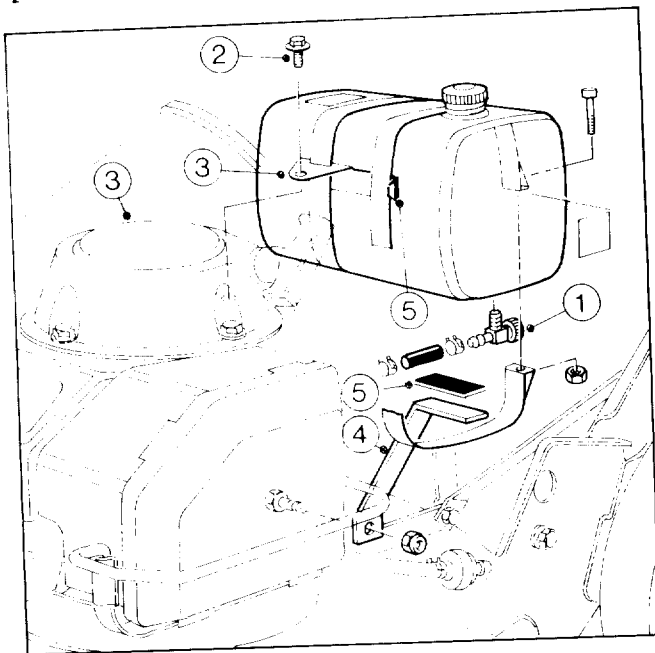

Figure 5

1. Fuel Valve
2. Flange Head Capscrew
3. Front Tank Mount
4. Bottom Tank Mount
5. Isolator Pad

2. Remove rear flange head capscrew securing starter recoil to blower housing on engine. Install front tank mount to starter recoil and blower housing with flange head capscrew previously removed, (Fig 5).

3. Mount lower tank mount to deck bracket with 5/16-18 x 1" lg. capscrew and locknut as shown in Fig. 5.

4. Secure isolator pads to back side of front tank mount and top side of lower tank mount. Trim length as necessary, (Fig. 5).

5. Bend mounting straps to conform to shape of tank. Bend straps so mounting tabs are to the rear.

6. Slip a mounting strap through slot in front tank mount (Fig. 5).

7. Position gas tank onto lower tank mount with gas cap toward left side of mower. Leave approximately 3/4" gap between tank and black bag adapter on right side of mower (Fig. 5).

8. Secure left side of tank to lower tank mount and right side of tank to front tank mount with mounting straps. Secure straps with 1/4-20 capscrews and nuts (Fig 5).

9. Cut off approximately 2-1/2" of fuel line and secure to engine fuel filter and fuel tank valve with hose clamps (Fig. 5).

10. Apply fuel tank decals to flat, dry, visible surface on fuel tank.

IMPORTANT: Attach blade replacement card to mower handle and blade decal to mower housing.

Note: Refer to engine operators manual for starting and maintenance instructions of engine.

