



**Count on it.**

**Operator's Manual**

**GrandStand<sup>®</sup> Mower**

**With 48in, 52in, or 60in TURBO FORCE<sup>®</sup>  
Cutting Unit**

**Model No. 74583—Serial No. 31400001 and Up**

**Model No. 74588—Serial No. 31400001 and Up**

**Model No. 74589—Serial No. 31400001 and Up**

**Model No. 79589—Serial No. 31400001 and Up**

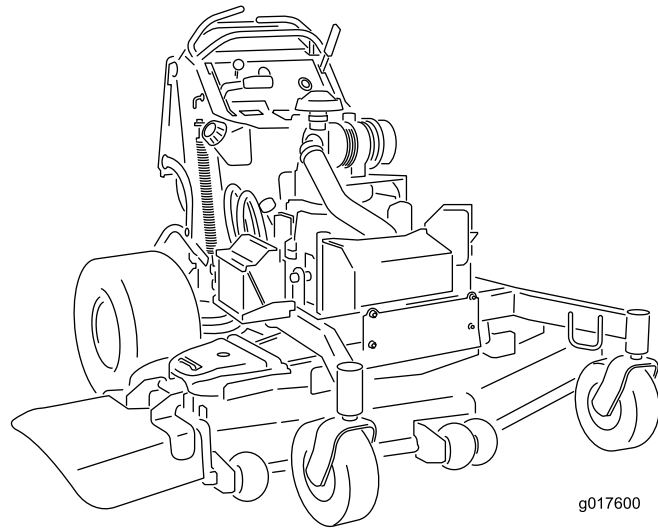

g017600



## ⚠ WARNING

### CALIFORNIA Proposition 65 Warning

This product contains a chemical or chemicals known to the State of California to cause cancer, birth defects, or reproductive harm.

The engine exhaust from this product contains chemicals known to the State of California to cause cancer, birth defects, or other reproductive harm.

This spark ignition system complies with Canadian ICES-002.

**Important:** This engine is not equipped with a spark arrester muffler. It is a violation of California Public Resource Code Section 4442 to use or operate the engine on any forest-covered, brush-covered, or grass-covered land. Other states or federal areas may have similar laws.

## ⚠ WARNING

Removing standard original equipment parts and accessories may alter the warranty, traction, and safety of the machine. Failure to use original Toro parts could cause serious injury or death. Making unauthorized changes to the engine, fuel or venting system, may violate EPA and CARB regulations.

Replace all parts including, but not limited to, tires, belts, blades, and fuel system components with original Toro parts.

The enclosed *Engine Owner's Manual* is supplied for information regarding the US Environmental Protection Agency (EPA) and the California Emission Control Regulation of emission systems, maintenance, and warranty. Replacements may be ordered through the engine manufacturer.

## Introduction

This rotary blade, riding lawn mower is intended to be used by professional, hired operators, or residential homeowners. It is designed primarily for cutting grass on well-maintained lawns on residential or commercial properties. It is not designed for cutting brush or for agricultural uses.

Read this information carefully to learn how to operate and maintain your product properly and to avoid injury and product damage. You are responsible for operating the product properly and safely.

You may contact Toro directly at [www.Toro.com](http://www.Toro.com) for product and accessory information, help finding a dealer, or to register your product.

Whenever you need service, genuine Toro parts, or additional information, contact an Authorized Service Dealer or Toro Customer Service and have the model and serial numbers of your product ready. Figure 1 identifies the location of the model and serial numbers on the product. Write the numbers in the space provided.

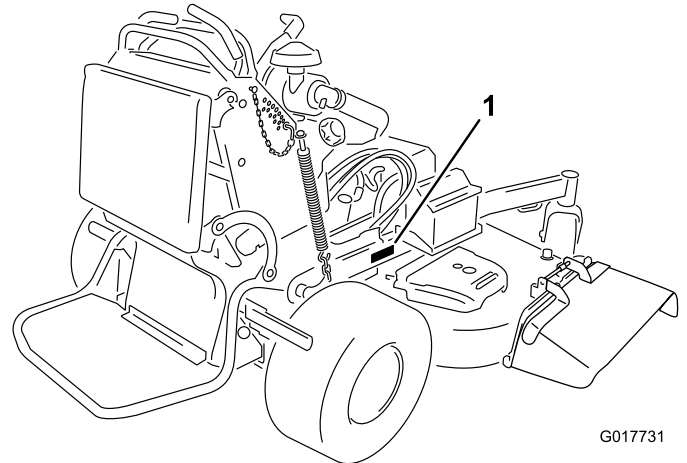

Figure 1

1. Location of the model and serial numbers

Model No. _____
Serial No. _____

This manual identifies potential hazards and has safety messages identified by the safety alert symbol (Figure 2), which signals a hazard that may cause serious injury or death if you do not follow the recommended precautions.



Figure 2

1. Safety and alert symbol

This manual uses 2 words to highlight information.

**Important** calls attention to special mechanical information and **Note** emphasizes general information worthy of special attention.

# Contents

Introduction .....	2	Servicing the Battery .....	38
Safety .....	4	Servicing the Fuses .....	39
Safe Operating Practices .....	4	Jump Starting the Machine .....	40
Toro Mower Safety .....	6	Drive System Maintenance .....	41
Slope Indicator .....	7	Adjusting the Tracking .....	41
Safety and Instructional Decals .....	8	Checking the Tire Pressure .....	42
Product Overview .....	12	Adjusting the Caster-pivot Bearing .....	42
Controls .....	12	Servicing the Caster Wheels and Bearings .....	43
Specifications .....	14	Servicing the Clutch .....	43
Operation .....	14	Cooling System Maintenance .....	45
Adding Fuel .....	14	Cleaning the Air-intake Screen .....	45
Checking the Engine-oil Level .....	15	Cleaning the Cooling System .....	45
Breaking in a New Machine .....	15	Servicing the Engine-oil Cooler .....	46
Think Safety First .....	15	Cleaning the Hydraulic-oil Cooler .....	46
Operating the Parking Brake .....	16	Servicing the Hydraulic-oil Cooler .....	46
Operating the Mower-Blade-control Switch (PTO) .....	16	Brake Maintenance .....	47
Operating the Throttle .....	16	Servicing the Brake .....	47
Operating the Ignition Switch .....	17	Belt Maintenance .....	49
Using the Fuel Shut-off Valve .....	17	Replacing the Mower-deck Belt .....	49
Starting and Stopping the Engine .....	17	Replacing the Pump-drive Belt .....	50
The Safety-interlock System .....	19	Controls System Maintenance .....	51
Operating the Platform .....	20	Adjusting the Motion-control-handle Positions .....	51
Driving Forward or Backward .....	20	Hydraulic System Maintenance .....	53
Stopping the Machine .....	22	Servicing the Hydraulic System .....	53
Using the Rotation Indicator .....	22	Mower Deck Maintenance .....	56
Pushing the Machine by Hand .....	22	Servicing the Cutting Blades .....	56
Transporting the Machine .....	22	Correcting the Mower Quality-of-Cut .....	58
Loading the Machine .....	23	Adjusting the Deck-lift Spring .....	61
Side Discharging or Mulching the Grass .....	23	Replacing the Grass Deflector .....	61
Adjusting the Height-of-Cut .....	24	Cleaning .....	62
Adjusting the Anti-scalp Rollers (for 60-inch models only) .....	24	Cleaning Under the Mower .....	62
Adjusting the Flow Baffle .....	24	Disposing of the Waste .....	62
Positioning the Flow Baffle .....	25	Storage .....	62
Using the Mid-size Weight .....	26	Cleaning and Storage .....	62
Maintenance .....	27	Troubleshooting .....	64
Recommended Maintenance Schedule(s) .....	27	Schematics .....	66
Pre-maintenance Procedures .....	28		
Raising the Mower for Access .....	28		
Releasing the Cushion for Rear Access .....	29		
Lubrication .....	30		
Lubricating the Machine .....	30		
Greasing the Front Caster Pivots .....	30		
Lubricate Caster-wheel Hubs .....	31		
Engine Maintenance .....	32		
Servicing the Air Cleaner .....	32		
Servicing the Engine Oil .....	33		
Servicing the Spark Plug .....	35		
Checking the Spark Arrester (if equipped) .....	36		
Fuel System Maintenance .....	36		
Draining the Fuel Tank .....	36		
Servicing the Fuel Filter .....	37		
Servicing the Electronic Fuel-injection System .....	37		
Electrical System Maintenance .....	38		

# Safety

**Improper use or maintenance by the operator or owner can result in injury.** To reduce the potential for injury, comply with these safety instructions, and pay attention to the safety alert symbol, which means **Caution, Warning, or Danger**—“personal safety instruction.” **Failure to comply with the instructions may result in personal injury or death.**

**Important:** This machine was manufactured according to the appropriate regulatory standards in effect at the time of manufacture. Modifying this machine in any way may cause it to be out of compliance with those standards and with the instructions in this Operator’s Manual. Modifications to this machine should only be made by either the manufacturer or an Authorized Toro Dealer.

This product is capable of amputating hands and feet. Follow all safety instructions to avoid serious injury or death.

The owner/user can prevent and is responsible for accidents or injuries occurring to people, or damage to property.

**Important:** The addition of attachments made by other manufacturers that do not meet American National Standards Institute certification will cause noncompliance of this machine.

## Safe Operating Practices

The following instructions are from ANSI standard B71.4-2012.

### Training

- Read the *Operator’s Manual* and other training material.

**Note:** If the operator(s) or mechanic(s) cannot read the manual language, it is the owner’s responsibility to explain this material to them.

- Become familiar with the safe operation of the equipment, operator controls, and safety signs.
- All operators and mechanics should be trained. The owner is responsible for training the users.
- Never let children or untrained people operate or service the equipment.

**Note:** Local regulations may restrict the age of the operator.

- The owner/user can prevent and is responsible for accidents or injuries occurring to himself or herself, other people, or damage to property.

## Preparation

- Evaluate the terrain to determine what accessories and attachments are needed to properly and safely perform the job. Only use accessories and attachments approved by the manufacturer.
- Wear appropriate clothing; including a hard hat, safety glasses, long pants, safety shoes (rubber boots, gloves, and hearing protection).

**Important:** Long hair, loose clothing or jewelry may get tangled in moving parts.

- Inspect the area where the equipment is to be used and ensure that all objects are removed from the area before use.
- Use extra care when handling fuels. They are flammable and vapors are explosive.
  - Use only an approved container.
  - Do not remove the fuel cap or add fuel with the engine running. Allow the engine to cool before refueling. Do not smoke near the machine when the engine is running.
  - Do not refuel or drain the machine indoors.
- Check that the operator’s presence controls, safety switches, and shields are attached and functioning properly. Do not operate the machine unless they are functioning properly.

## Operation

- Lightning can cause severe injury or death. If lightning is seen, or thunder is heard in the area, do not operate the machine; seek shelter.
- Do not run an engine in an enclosed area.
- Only operate in well-lit areas, keeping away from holes and hidden hazards.
- Ensure that all drives are in neutral and that the parking brake is engaged before starting engine. Only start the engine from the operator’s position.
- Make sure that you have good footing while using this machine, especially when backing up.

**Note:** Reduced footing could cause slipping.

- Slow down and use extra care on hillsides. Be sure to travel side to side on hillsides. Turf conditions can affect the stability of the machine. Use caution while operating near drop-offs.
- Slow down and use caution when making turns and when changing directions on slopes.
- Do not raise the mower deck with the blades running.
- Do not operate the machine without the PTO shield or other guards securely in place. Be sure all interlocks are attached, adjusted properly, and functioning properly.
- Do not operate with the discharge deflector raised, removed or altered, unless using a grass catcher.

- Do not change the engine governor setting or overspeed the engine.
- Stop on level ground, disengage drives, engage the parking brake (if provided), shut off the engine before leaving the operator's position for any reason, including emptying the catchers or unclogging the chute.
- Stop equipment and inspect the blades after striking objects or if an abnormal vibration occurs. Make the necessary repairs before resuming operations.
- Keep your hands and feet away from the cutting unit.
- Look behind and down before backing up to ensure a clear path.
- Keep pets and bystanders away from an operating machine.
- Slow down and use caution when making turns and crossing roads and sidewalks. Stop the blades if you are not mowing.
- Be aware of the mower-discharge direction and do not point it at anyone.
- Do not operate the mower under the influence of alcohol or drugs.
- Use care when loading or unloading the machine into or from a trailer or truck.
- Use care when approaching blind corners, shrubs, trees, or other objects that may obscure vision.
- If fuel is spilled on clothing, change your clothing immediately.
- Do not overfill fuel tank. Replace fuel cap and tighten securely.

## Maintenance and Storage

- Disengage drives, set the parking brake, stop the engine, and remove the key or disconnect spark-plug wire. Wait for all movement to stop before adjusting, cleaning, or repairing.
- Clean grass and debris from the cutting unit, drives, mufflers, and engine to help prevent fires.
- Clean up oil or fuel spillage.
- Let the engine cool before storing.
- Do not store fuel near flames or drain indoors.
- Do not allow untrained personnel to service machine.
- Use jack stands to support components when required.
- Carefully release pressure from components with stored energy.
- Disconnect the battery or remove the spark-plug wire before making any repairs. Disconnect the negative terminal first and the positive terminal last. Reconnect the positive first and negative last.
- Use care when checking the blades. Wrap the blade(s) or wear gloves, and use caution when servicing them. Only replace blades; do not straighten or weld them.
- Keep hands and feet away from moving parts. If possible, do not make adjustments with the engine running.
- Keep all parts in good working condition and all hardware tightened. Replace all worn or damaged decals.

## Safe handling of fuels

- To avoid personal injury or property damage, use extreme care in handling gasoline. Gasoline is extremely flammable and the vapors are explosive.
- Extinguish all cigarettes, cigars, pipes, and other sources of ignition.
- Use only an approved fuel container.
- Do not remove the fuel cap or add fuel with the engine running.
- Allow the engine to cool before fueling.
- Do not fuel the machine indoors.
- Do not store the machine or fuel container where there is an open flame, spark, or pilot light such as on a water heater or on other appliances.
- Do not fill containers inside a vehicle, on a truck, or on a trailer bed with a plastic liner. Always place containers on the ground away from your vehicle before filling.
- Remove equipment from the truck or trailer and fuel it on the ground. If this is not possible, then add fuel with such equipment as a portable container, rather than from a fuel dispenser nozzle.
- Keep the nozzle in contact with the rim of the fuel tank or container opening at all times until fueling is complete. Do not use a nozzle lock open device.

## Hauling

- Use care when loading or unloading the machine into a trailer or a truck.
- Use full-width ramps for loading machine into a trailer or a truck.
- Tie the machine down securely using straps, chains, cable, or ropes. Both front and rear straps should be directed down and outward from the machine.

# Toro Mower Safety

The following list contains safety information specific to Toro products and other safety information you must know.

This product is capable of amputating hands and feet, and throwing objects. Always follow all safety instructions to avoid serious injury or death.

This product is designed for cutting and recycling grass, or, when equipped with a grass bagger, for catching cut grass. Any use for purposes other than these could prove dangerous to the user and bystanders.

## General Operation

- Be sure that the area is clear of bystanders before mowing. Stop the machine if anyone enters the area.
- Do not touch equipment or attachment parts which may be hot from operation. Allow all of the parts to cool before attempting to maintain, adjust, or service the machine.
- Use only Toro-approved attachments. Warranty may be voided if used with any unapproved attachments.
- Check carefully for overhead clearances (i.e. branches, doorways, electrical wires, etc.) before operating under any objects, and do not contact them.
- Slow down before making turns and use extra caution.
- Use caution when riding the platform over curbs, rocks, roots, or other obstructions.
- Look behind and down before backing up to ensure a clear path. Use extra care when operating in reverse.
- Do not jerk the controls; use a steady motion.
- When loading or unloading the machine, use one full-width ramp that is wide enough to extend beyond the width of the machine.
- Do not carry passengers.
- Do not carry equipment on the machine.

## Slope Operation

All slopes and ramps require extra caution. If you feel uneasy on a slope, do not mow it.

- Remove obstacles such as rocks, tree limbs, etc. from the mowing area.
- Watch for holes, ruts or bumps.

**Note:** Tall grass can hide obstacles.

- Use caution near drop-offs, ditches, or embankments.

**Note:** The machine could suddenly turn over if a wheel goes over the edge of a cliff or ditch, or if an edge caves in.

- Use extra care with grass catchers or other attachments.

**Note:** These can change the stability of the machine.

- Keep all movement on slopes slow and gradual.
- Do not make sudden changes in speed or direction.
- Mow slopes side to side.
- Do not mow slopes greater than 20 degrees.

## Service

- Do not store the machine or a fuel container inside where there is an open flame, such as near a water heater or furnace.
- Keep the nuts and bolts tight, especially the blade-attachment bolts.
- Never remove or tamper with safety devices. Check their proper operation regularly. Never do anything to interfere with the intended function of a safety device or to reduce the protection provided by a safety device.
- To best protect your investment and maintain optimal performance of your Toro equipment, count on Toro genuine parts. When it comes to reliability, Toro delivers replacement parts designed to the exact engineering specifications of our equipment. For peace of mind, insist on Toro genuine parts.
- Check brake operation frequently. Adjust and service as required.

# Slope Indicator



G011841

2

Figure 3

This page may be copied for personal use.

1. The maximum slope you can safely operate the machine on is **20 degrees**. Use the slope chart to determine the degree of slope of hills before operating. **Do not operate this machine on a slope greater than 20 degrees**. Fold along the appropriate line to match the recommended slope.
2. Align this edge with a vertical surface, a tree, building, fence pole, etc.
3. Example of how to compare slope with folded edge.

# Safety and Instructional Decals



Safety decals and instructions are easily visible to the operator and are located near any area of potential danger. Replace any decal that is damaged or lost.

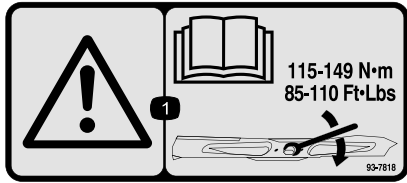

93-7818

1. Warning—read the *Operator's Manual* for instructions on torquing the blade bolt/nut to 115 to 149 N-m (85 to 110 ft-lb).



## Battery Symbols

Some or all of these symbols are on your battery

- |  |  |
|--|--|
| 1. Explosion hazard                    | 6. Keep bystanders a safe distance from the battery.                           |
| 2. No fire, open flame, or smoking.    | 7. Wear eye protection; explosive gases can cause blindness and other injuries |
| 3. Caustic liquid/chemical burn hazard | 8. Battery acid can cause blindness or severe burns.                           |
| 4. Wear eye protection                 | 9. Flush eyes immediately with water and get medical help fast.                |
| 5. Read the <i>Operator's Manual</i> . | 10. Contains lead; do not discard.   |



106-5517

1. Warning—do not touch the hot surface.

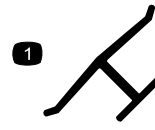

## Manufacturer's Mark

1. Indicates the blade is identified as a part from the original machine manufacturer.

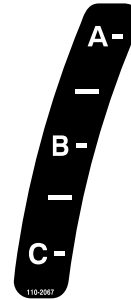

110-2067

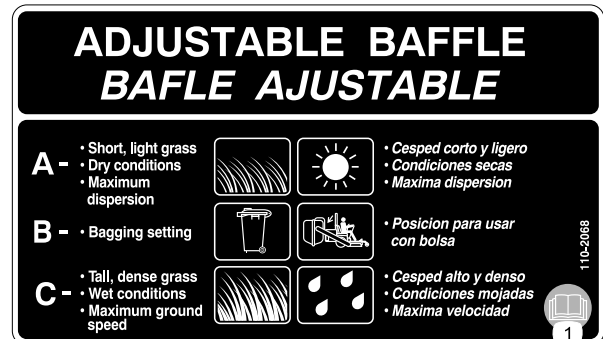

110-2068

1. Read the *Operator's Manual*.

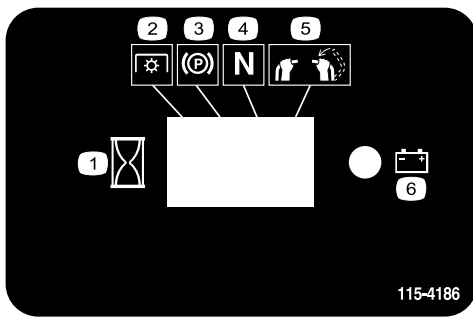

115-4186

1. Interval
2. Power Take-off (PTO)
3. Parking brake
4. Neutral
5. Operator presence switch
6. Battery



116-3290

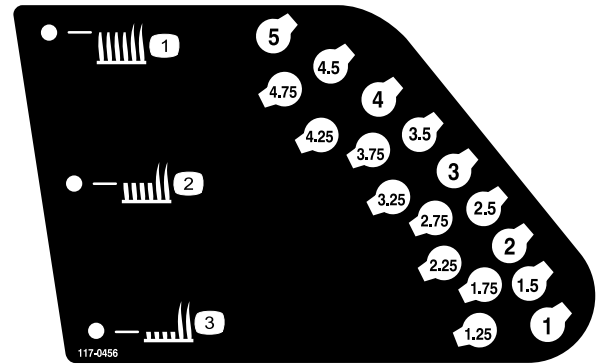

117-0456

1. Height of cut (HOC)—high
2. Height of cut (HOC)—medium
3. Height of cut (HOC)—low

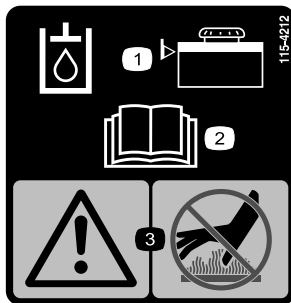

115-4212

1. Hydraulic oil level
2. Read the *Operator's Manual*.
3. Warning—do not touch the hot surface.



119-0217

1. Warning—stop the engine; stay away from moving parts; keep all guards and shields in place.



116-3267

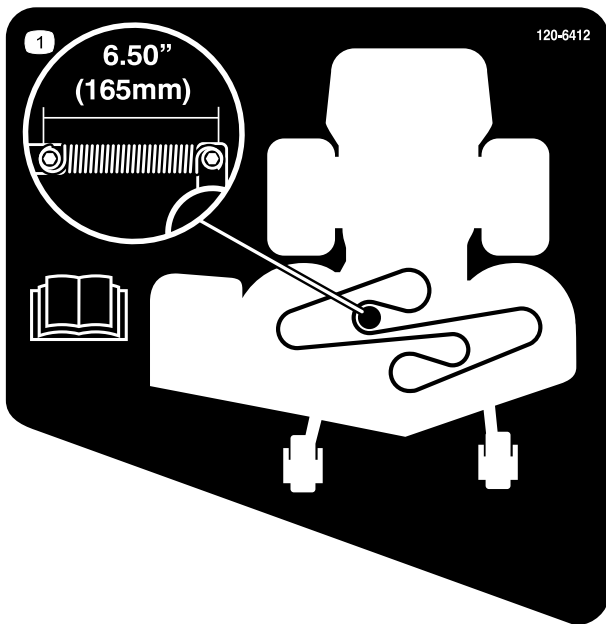

120-6412

1. Belt tension adjustment; read the *Operator's Manual* for more information.

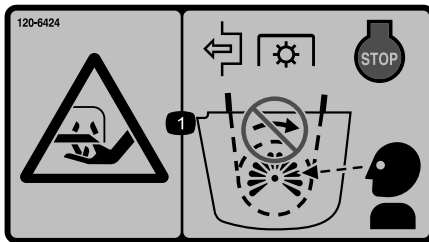

120-6424

1. Cutting/dismemberment hazard, hand—disengage the power take-off (PTO), stop the engine and watch for all moving parts to stop.

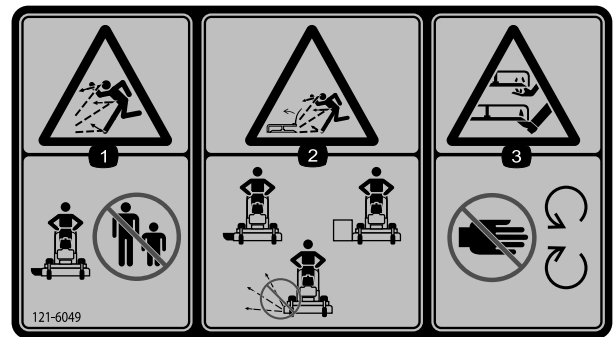

121-6049

1. Thrown object hazard—keep bystanders away from the machine.
2. Thrown object hazard, mower—do not operate the mower with guards or shields removed.
3. Cutting/dismemberment hazard of hand or foot, mower blade—keep hands away from moving parts.

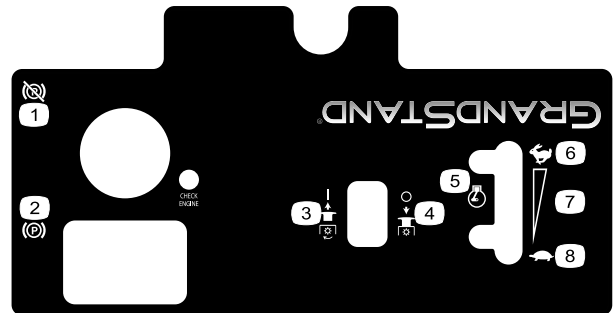

120-6497

1. Parking brake—disengage
2. Parking brake—engage
3. Power Take-off (PTO)—engage
4. Power Take-off (PTO)—disengage
5. Engine speed
6. Fast
7. Continuous variable setting
8. Slow

## SERVICE AID 1

**DAILY:**

- CHECK SAFETY INTERLOCK SYSTEM
- CLEAN UNDER MOWER DECK
- CLEAN AIR INTAKE SCREEN
- CHECK ENGINE OIL LEVEL
- CLEAN HYDRAULIC COOLER (IF EQUIPPED)

**50 HOURS:**

- CHECK TIRE PRESSURE
- CHECK HYDRAULIC FLUID LEVEL
- CHECK ENGINE AIR FILTERS
- GREASE LIFT LINKAGE PIVOTS
- GREASE BLADE SPINDLES

See operator's manual for additional details.

**100 HOURS:**

- CHECK BATTERY
- CHANGE ENGINE OIL
- CHECK SPARK PLUGS
- CHECK BELTS
- CHECK CLUTCH GAP

**200 HOURS:**

- CHANGE ENGINE OIL FILTER
- CHANGE ENGINE AIR FILTERS

**ANNUALLY:**

- CHANGE FUEL FILTER
- CHANGE HYDRAULIC OIL & FILTER
- GREASE FRONT CASTER PIVOTS
- GREASE FRONT WHEEL BEARINGS

SERVICE MORE OFTEN IN DIRTY OR DUSTY CONDITIONS

121-5972

CALIFORNIA SPARK ARRESTER WARNING

Operation of this equipment may create sparks that can start fires around dry vegetation. A spark arrester may be required. The operator should contact local fire agencies for laws or regulations relating to fire prevention requirements.

121-5972

1. Read the *Operator's Manual* before servicing or performing maintenance.

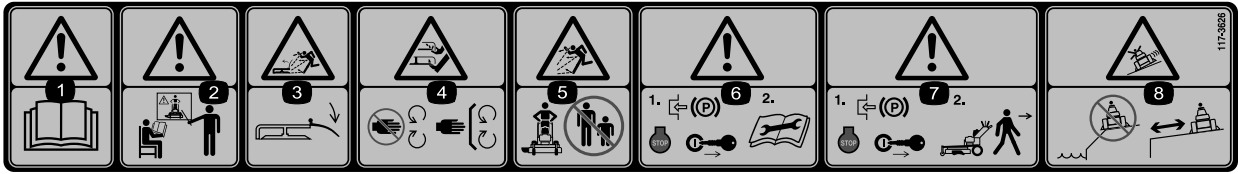

117-3626

1. Warning—read the *Operator's Manual*.
2. Warning—do not operate this machine unless you are trained.
3. Thrown object hazard—keep deflector in place.
4. Cutting, dismemberment hazard of hand or foot—stay away from moving parts and keep all guards and shields in place.
5. Thrown object hazard—keep bystanders a safe distance from the machine.
6. Warning—engage the parking brake, stop the engine and remove the spark plug wire before performing any maintenance on the machine.
7. Warning—engage the parking brake and stop the engine before leaving the machine.
8. Sliding and loss of control hazard—do not operate the machine near drop-offs or water; keep a safe distance from drop-offs.



119-8727

1. Traction control
2. Fast
3. Slow
4. Neutral
5. Reverse
6. Power Take-off (PTO)—disengage
7. Operator presence switch

# Product Overview

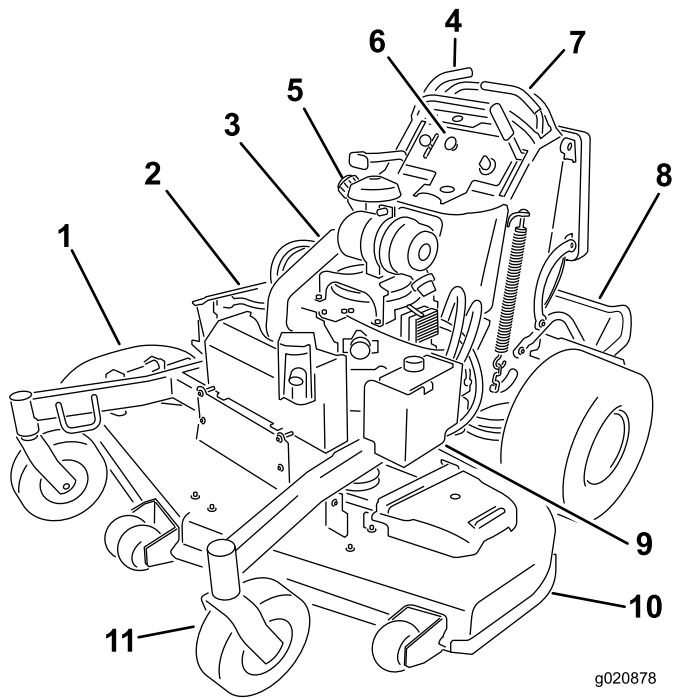

Figure 4

- |   |                             |
|---|-----------------------------|
| 1. Side-discharge chute                 | 7. Control levers           |
| 2. Battery                              | 8. Platform (down position) |
| 3. Engine                               | 9. Hydraulic tank           |
| 4. Fuel shut-off valve (behind cushion) | 10. Mower deck              |
| 5. Fuel tank                            | 11. Front caster wheel      |
| 6. Controls                             |                             |

# Controls

Become familiar with all the controls (Figure 5) before you start the engine and operate the machine.

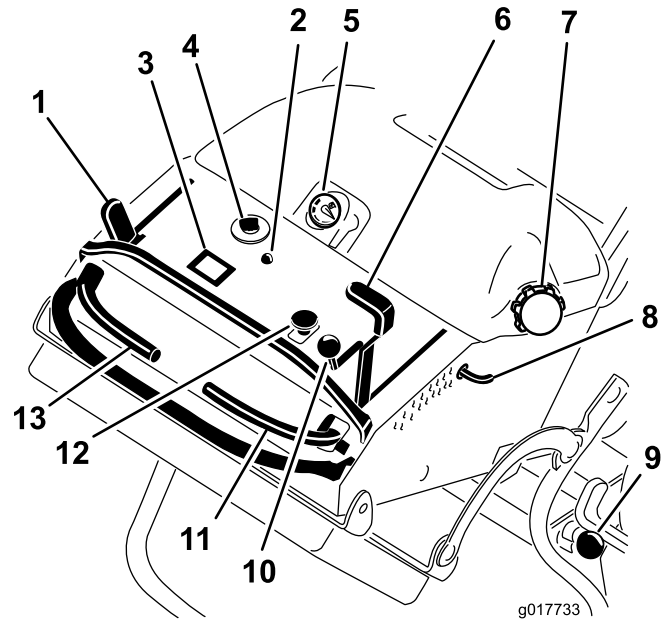

Figure 5

- |                                      |                                |
|--------------------------------------|--------------------------------|
| 1. Parking-brake lever               | 8. Height-of-cut pin           |
| 2. Malfunction-indicator light (MIL) | 9. Platform latch              |
| 3. Hour meter                        | 10. Throttle control           |
| 4. Ignition switch                   | 11. Right motion-control lever |
| 5. Fuel gauge                        | 12. Blade-control switch (PTO) |
| 6. Height-of-cut lever               | 13. Left motion-control lever  |
| 7. Fuel cap                          |                                |

## Hour Meter

The hour meter records the number of hours the engine has operated. It operates when the engine is running. Use these times for scheduling regular maintenance (Figure 5).

## Fuel Gauge

The fuel gauge is located on the top, middle of the tank (Figure 5).

## Safety-interlock Indicators

Symbols on the hour meter indicate with a black triangle that the interlock component is in the correct position (Figure 6).

## Battery-indicator Light

If the ignition key is turned to the On position for a few seconds, the battery voltage will be displayed in the area where the hours are normally displayed.

The battery light turns on when the ignition is turned on and when the charge is below the correct operating level (Figure 6).

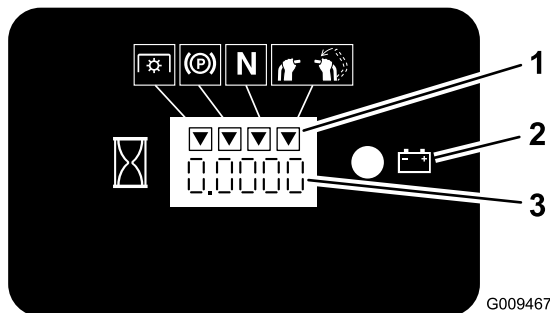

**Figure 6**

1. Safety-interlock symbols
2. Battery light
3. Hour meter

## Motion-control Levers

The motion-control levers are used to drive the machine forward, reverse, and turn either direction.

## Fuel Shut-off Valve

Close the fuel shut-off valve (located behind the operator cushion on the right-hand side of the fuel tank) when transporting or storing the mower.

## Attachments/Accessories

A selection of Toro approved attachments and accessories is available for use with the machine to enhance and expand its capabilities. Contact your Authorized Service Dealer or Distributor or go to [www.Toro.com](http://www.Toro.com) for a list of all approved attachments and accessories.

## Throttle Control

The throttle control is variable between **Fast** and **Slow**.

## Electronic-control Unit Malfunction-indicator Light

The electronic-control unit (ECU) continuously monitors the operation of the EFI system.

If a problem or fault within the system is detected, the malfunction-indicator light (MIL) is illuminated.

The MIL is the red light located in the console panel.

Once the MIL illuminates, initial trouble shooting checks should be made.

If these checks do not correct the problem, further diagnosis and servicing by an Authorized Service Dealer is necessary.

## Choke

Use the choke to start a cold engine.

## Blade-control Switch (PTO)

The blade-control switch (PTO) is used to engage the electric clutch to drive the mower blades with the right side motion-control lever in the center, unlocked position. Pull the switch up to engage the blades and release. To disengage the blades, push the blade-control switch (PTO) down or move or release the right side motion-control lever into the neutral-lock position.

## Ignition Switch

This switch is used to start the mower engine and has three positions: **Off**, **Run** and **Start**.

# Specifications

**Note:** Specifications and design are subject to change without notice.

## 48-inch mowers:

Width with deflector down	161.3 cm (63.5 inches)
Width with deflector raised	125.7 cm (49.5 inches)
Length with platform down	188 cm (74 inches)
Length with platform up	149.9 cm (59 inches)
Height	121.9 cm (48 inches)
Weight for model <b>74588</b>	412 kg (909 lbs)

## 52-inch mowers:

Width with deflector down	171.7 cm (67.6 inches)
Width with deflector raised	135.9 cm (53.5 inches)
Length with platform down	188 cm (74 inches)
Length with platform up	149.9 cm (59 inches)
Height	121.9 cm (48 inches)
Weight for model <b>74589</b>	413.7 kg (912 lbs)
Weight for model <b>79589</b>	416.4 kg (918 lbs)

## 60-inch mowers:

Width with deflector down	192.2 cm (76 inches)
Length with platform down	188 cm (74 inches)
Length with platform up	147.3 cm (58 inches)
Height	121.9 cm (48 inches)
Weight for model <b>74583</b>	420.9 kg (928 lbs)

# Operation

**Note:** Determine the left and right sides of the machine from the normal operating position.

## Adding Fuel

- For best results, use only clean, fresh (less than 30 days old), unleaded gasoline with an octane rating of 87 or higher ((R+M)/2 rating method).
- **Ethanol:** Gasoline with up to 10% ethanol (gasohol) or 15% MTBE (methyl tertiary butyl ether) by volume is acceptable. Ethanol and MTBE are not the same. Gasoline with 15% ethanol (E15) by volume is not approved for use. **Never use gasoline that contains more than 10% ethanol by volume**, such as E15 (contains 15% ethanol), E20 (contains 20% ethanol), or E85 (contains up to 85% ethanol). Using unapproved gasoline may cause performance problems and/or engine damage which may not be covered under warranty.
- **Do not** use gasoline containing methanol.
- **Do not** store fuel either in the fuel tank or fuel containers over the winter unless a fuel stabilizer is used.
- **Do not** add oil to gasoline.

## **▲ DANGER**

**In certain conditions, gasoline is extremely flammable and highly explosive. A fire or explosion from gasoline can burn you and others and can damage property.**

- **Fill the fuel tank outdoors, in an open area, when the engine is cold. Wipe up any gasoline that spills.**
- **Never fill the fuel tank inside an enclosed trailer.**
- **Do not fill the fuel tank completely full. Add gasoline to the fuel tank until the level is 6 to 13 mm (1/4 to 1/2 inch) below the bottom of the filler neck. This empty space in the tank allows gasoline to expand.**
- **Never smoke when handling gasoline, and stay away from an open flame or where gasoline fumes may be ignited by a spark.**
- **Store gasoline in an approved container and keep it out of the reach of children. Never buy more than a 30-day supply of gasoline.**
- **Do not operate without entire exhaust system in place and in proper working condition.**

## **⚠ DANGER**

In certain conditions during fueling, static electricity can be released causing a spark which can ignite the gasoline vapors. A fire or explosion from gasoline can burn you and others and can damage property.

- Always place gasoline containers on the ground away from your vehicle before filling.
- Do not fill gasoline containers inside a vehicle or on a truck or trailer bed because interior carpets or plastic truck bed liners may insulate the container and slow the loss of any static charge.
- When practical, remove gas-powered equipment from the truck or trailer and refuel the equipment with its wheels on the ground.
- If this is not possible, then refuel such equipment on a truck or trailer from a portable container, rather than from a gasoline dispenser nozzle.
- If a gasoline dispenser nozzle must be used, keep the nozzle in contact with the rim of the fuel tank or container opening at all times until fueling is complete.

## **⚠ WARNING**

Gasoline is harmful or fatal if swallowed. Long-term exposure to vapors can cause serious injury and illness.

- Avoid prolonged breathing of vapors.
- Keep face away from nozzle and gas tank or conditioner bottle opening.
- Avoid contact with skin; wash off spillage with soap and water.

## **Using Stabilizer/Conditioner**

Use a fuel stabilizer/conditioner in the machine to provide the following benefits:

- Keeps gasoline fresh during storage of 90 days or less. For longer storage it is recommended that the fuel tank be drained.
- Cleans the engine while it runs
- Eliminates gum-like varnish buildup in the fuel system, which causes hard starting

**Important:** Do not use fuel additives containing methanol or ethanol.

Add the correct amount of gas stabilizer/conditioner to the gas.

**Note:** A fuel stabilizer/conditioner is most effective when mixed with fresh gasoline. To minimize the chance of varnish deposits in the fuel system, use fuel stabilizer at all times.

## **Filling the Fuel Tank**

1. Shut the engine off and set the parking brake.
2. Clean around the fuel tank cap and remove the cap. Add unleaded regular gasoline to the fuel tank, until the level is 6 to 13 mm (1/4 to 1/2 inch) below the bottom of the filler neck. This space in the tank allows the gasoline to expand. Do not fill the fuel tank completely full.
3. Install the fuel tank cap securely. Wipe up any gasoline that may have spilled.

## **Checking the Engine-oil Level**

Before you start the engine and use the machine, check the oil level in the engine crankcase; refer to Checking the Engine-oil Level (page 33).

## **Breaking in a New Machine**

New engines take time to develop full power. Mower decks and drive systems have higher friction when new, placing additional load on the engine. Allow 40 to 50 hours of break-in time for new machines to develop full power and best performance.

## **Think Safety First**

Carefully read all the safety instructions and decals in the safety section. Knowing this information could help you or any bystanders avoid injury.

The use of protective equipment for eyes, hearing, feet and head is recommended.

## **⚠ CAUTION**

**This machine produces sound levels in excess of 85 dBA at the operator's ear and can cause hearing loss through extended periods of exposure.**

**Wear hearing protection when operating this machine.**

## Operating the Parking Brake

Always set the parking brake when you stop the machine or leave it unattended. Before each use, check the parking brake for proper operation.

If the parking brake does not hold securely, adjust it; refer to Servicing the Brake (page 47).

### **CAUTION**

Children or bystanders may be injured if they move or attempt to operate the machine while it is unattended.

Always remove the ignition key and set the parking brake when leaving the machine unattended, even if just for a few minutes.

## Setting the Parking Brake

Pull the parking brake lever rearward and over into engaged position (Figure 7).

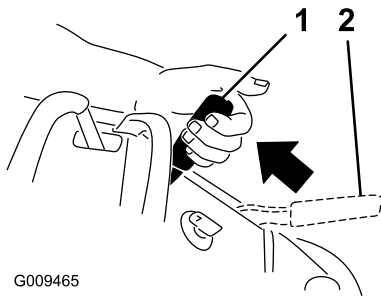

Figure 7

1. Parking brake engaged
2. Parking brake released

## Releasing the Parking Brake

Pull the brake lever back and over into the slot and push the parking brake lever forward.

## Operating the Mower-Blade-control Switch (PTO)

The blade-control switch (PTO) is used in conjunction with the right side motion-control lever to engage and disengage the mower blades.

## Engaging the Mower Blades (PTO)

1. To engage the mower blades, move the right side motion-control lever to the center, unlocked position.
2. Pull the blade-control switch (PTO) up and release it while holding down the right side motion-control lever in the center, unlocked position.

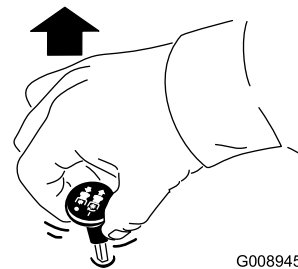

G008945

Figure 8

## Disengaging the Mower Blades (PTO)

The following are two options for disengaging the mower blades.

- Push the blade-control switch (PTO) down to the Off position.
- Move the motion-control levers to neutral and move the right side motion-control lever into the neutral-lock position.

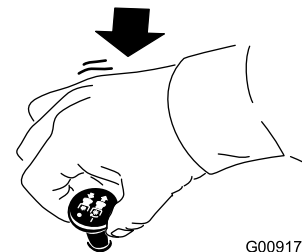

G009174

Figure 9

## Operating the Throttle

The throttle control moves between **Fast** and **Slow** positions (Figure 10).

Always use the Fast position when turning on the mower deck with the blade-control switch (PTO).

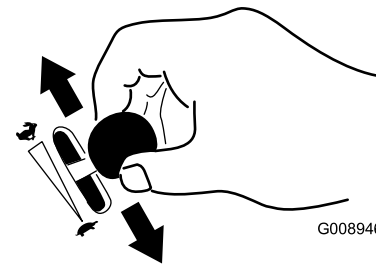

G008946

Figure 10

## Operating the Ignition Switch

1. Turn the ignition key to the Start position (Figure 11). When the engine starts, release the key.

**Important:** Do not engage the starter for more than 5 seconds at a time. If the engine fails to start, allow a 15 second cool-down period between attempts. Failure to follow these instructions can burn out the starter motor.

**Note:** Additional starting cycles may be required when starting the engine for the first time after the fuel system has been without fuel completely.

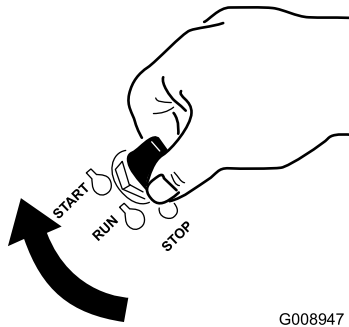

Figure 11

G008947

2. Turn the ignition key to stop to turn off the engine.

## Using the Fuel Shut-off Valve

Close the fuel shut-off valve for transport, maintenance, and storage (Figure 12).

Ensure that the fuel shut-off valve is open when starting the engine.

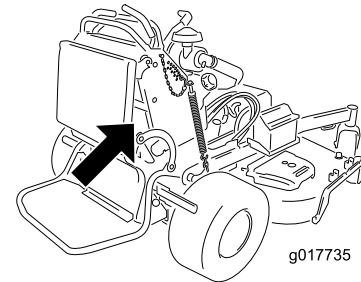

g017735

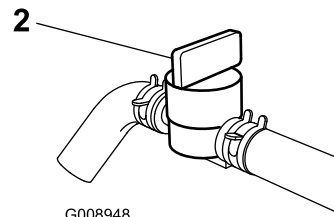
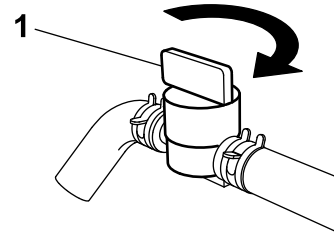

G008948

Figure 12

1. On position

2. Off position

## Starting and Stopping the Engine

### Starting the Engine

1. Connect the wires to the spark plugs.
2. Open the fuel valve.
3. Move the right motion-control lever to neutral locked position.
4. Set the parking brake; refer to Setting the Parking Brake.
5. Move the blade-control switch (PTO) to the **Off** position.
6. Move the throttle lever midway between the **Slow** and **Fast** positions.

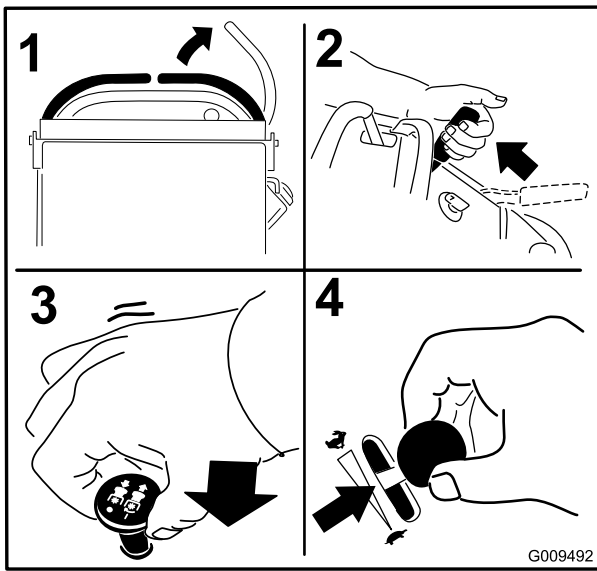

Figure 13

## Stopping the Engine

### ⚠ CAUTION

Children or bystanders may be injured if they move or attempt to operate the tractor while it is unattended.

Always remove the ignition key and set the parking brake when leaving the machine unattended, even if just for a few minutes.

Let the engine idle at slow throttle (turtle) for 60 seconds before turning the ignition switch off.

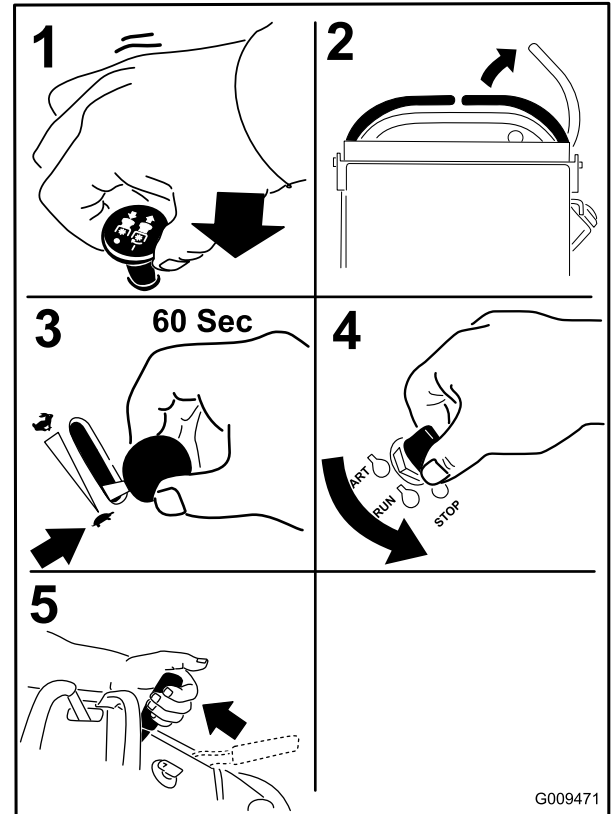

Figure 15

- Turn the ignition key to the Start position (Figure 11). When the engine starts, release the key.

**Important:** Do not engage the starter for more than 5 seconds at a time. If the engine fails to start, allow a 15 second cool-down period between attempts. Failure to follow these instructions can burn out the starter motor.

**Note:** Additional starting cycles may be required when starting the engine for the first time after the fuel system has been without fuel completely.

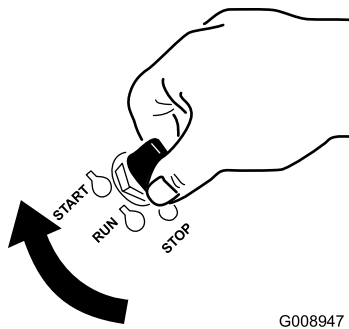

Figure 14

- Off position
- Run position
- Start position

**Important:** Make sure the fuel shut-off valve is closed before transporting or storing the machine, as fuel leakage may occur. Before storing the machine, pull wire off spark plug(s) to prevent possibility of accidental starting.

# The Safety-interlock System

## ⚠ CAUTION

If safety-interlock switches are disconnected or damaged the machine could operate unexpectedly causing personal injury.

- Do not tamper with the interlock switches.
- Check the operation of the interlock switches daily and replace any damaged switches before operating the machine.

## Understanding the Safety-interlock System

The safety-interlock system is designed to prevent the mower blades from rotating unless:

- The right side motion-control lever is moved to the center, unlocked position.
- The blade-control switch (PTO) is pulled **on**.

The safety-interlock system is designed to stop the mower blades if you move or release the right side motion-control lever into the neutral-lock position.

The hour meter has symbols to notify the user when the interlock component is in the correct position. When the component is in the correct position, a triangle will light up in the corresponding square.

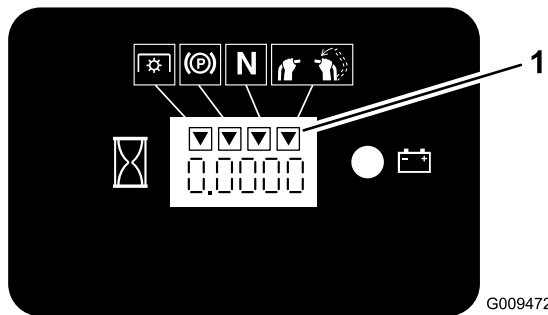

Figure 16

1. Triangles light up when the interlock components are in the correct position

## Testing the Safety-interlock System

**Service Interval:** Before each use or daily

Test the safety-interlock system before you use the machine each time.

**Note:** If the safety system does not operate as described below, have an Authorized Service Dealer repair the safety system immediately.

1. Start the engine; refer to Starting the Engine (page 17).
2. Set the parking brake.
3. Move the right side motion-control lever to the center, unlocked position.

**Note:** The blades should not rotate.

4. Move the motion-control levers forward.

**Note:** The engine should stop running.

5. Start the engine and release the parking brake.
6. Move the right side motion-control lever to the center, unlocked position.
7. Continue holding the right side motion-control lever in the center, unlocked position, pull up on the blade-control switch (PTO), and release.

**Note:** The clutch should engage and the mower blades rotate.

8. Move or release the right side motion-control lever into the neutral-lock position.

**Note:** The blades should stop rotating and the engine continues to run.

9. Push the blade-control switch down and move the right side motion-control lever to the center, unlocked position.
10. Continue holding the right side motion-control lever in the center, unlocked position, pull up on the blade-control switch (PTO), and release.

**Note:** The clutch should engage and the mower blades rotate.

11. Push the blade-control switch (PTO) down to the Off position.

**Note:** The blades should stop rotating.

12. With the engine running, pull up the blade-control switch (PTO) and release it without holding right side motion-control lever to the center, unlocked position.

**Note:** The blades should not rotate.

## ⚠ WARNING

The operator platform is heavy and may cause injury when lowering and raising the operator platform. The platform may suddenly drop if not supported when the latch pin is pulled out.

- Do not put your hands or fingers in the platform-pivot area when lowering or raising the operator platform.
- Make sure the platform is supported when the latch pin is pulled out.
- Make sure the latch secures the platform when folding it in the up position. Push it tight against the cushion for the latch pin to lock into place.
- Keep bystanders away when raising or lowering the platform.

# Operating the Platform

The machine can be used with the platform in the up or down position. It is the operator's preference on which position to use.

## Operating the Machine with the Platform Up

Operating the machine with the platform up is recommended for the following:

- Mowing near drop-offs
- Mowing small areas where the machine is too large
- Areas with low, over-hanging branches or obstacles
- Loading the machine for transport
- Driving up slopes

To raise the platform, pull the back of the platform up so that the latch pin and knob lock it into place. Push it tight against the cushion for the latch pin to lock it into place.

## Operating the Machine with the Platform Down

Operating the machine with the platform down is recommended for the following:

- Mowing most areas
- Driving across slopes
- Driving down slopes

To lower the platform, push the platform forward against the cushion to release pressure on the latch pin, then pull the knob out, and lower the platform (Figure 17).

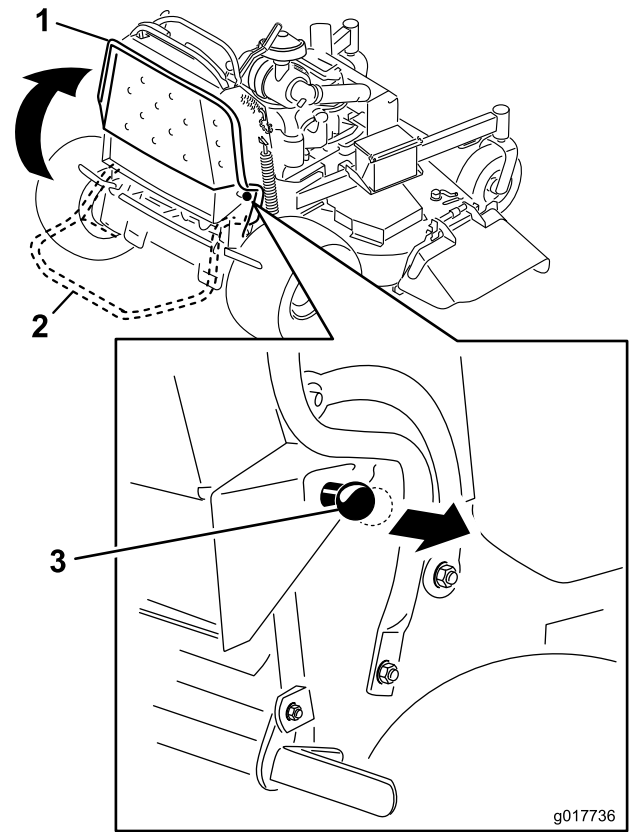

Figure 17

1. Platform up
2. Platform down
3. Pull the knob out to release the platform.

## Driving Forward or Backward

The throttle control regulates the engine speed as measured in rpm (revolutions per minute). Place the throttle control in the Fast position for best performance. Always operate the machine in the full throttle position when mowing.

### **CAUTION**

The machine can spin very rapidly. The operator may lose control of machine, and may cause personal injury or damage to machine.

Slow the machine down before making sharp turns.

## Driving Forward

1. Release the parking brake; refer to Releasing the Parking Brake (page 16).
2. Move the right side motion-control lever to the center, unlocked position.

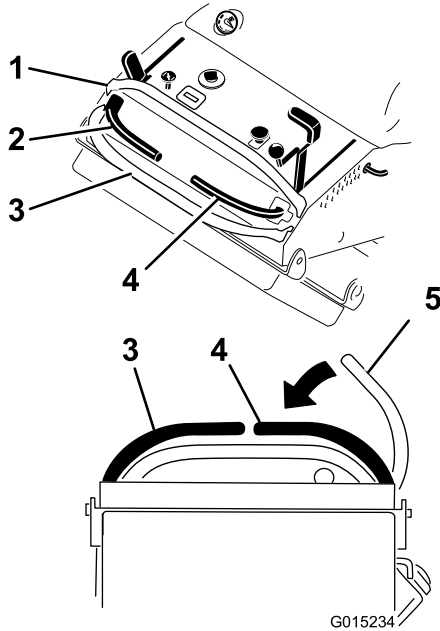

Figure 18

- |                        |   |
|------------------------|---|
| 1. Front reference bar | 4. Right control lever                              |
| 2. Left control lever  | 5. Right control lever in the neutral lock position |
| 3. Rear reference bar  |   |

3. To go forward, move the speed-control lever to the desired speed.
4. Slowly push the motion-control levers forward (Figure 19).

**Note:** The engine will kill if a motion-control lever is moved with the parking brake engaged.

**Note:** The farther you move the motion-control levers in either direction, the faster the machine will move in that direction.

**Note:** To stop, pull the motion-control levers back to the neutral position.

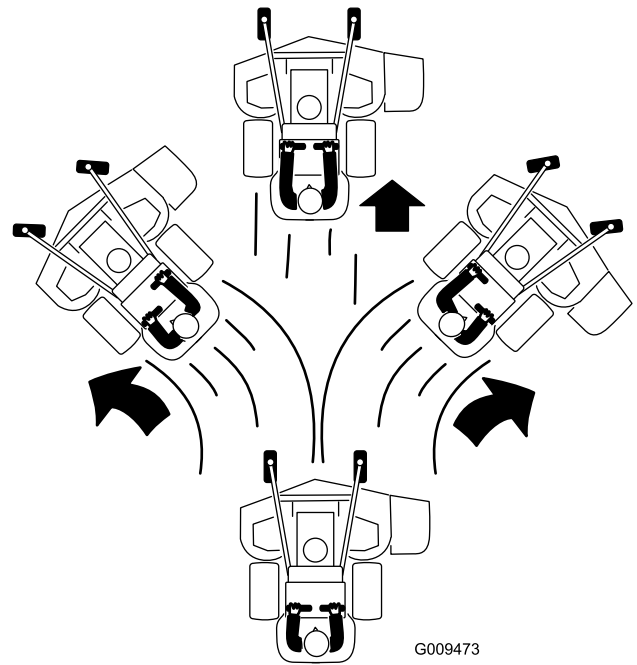

Figure 19

## Driving Backward

1. Move the right side motion-control lever to the center, unlocked position.
2. Slowly pull the motion-control levers rearward (Figure 20).

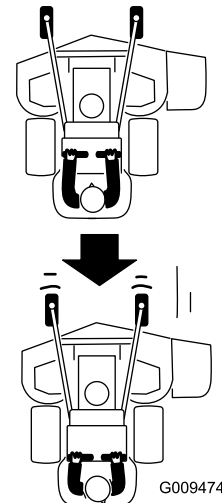

Figure 20

## Stopping the Machine

To stop the machine, move the motion-control levers to neutral, move the right side motion-control lever into the neutral-lock position, disengage the power-take off (PTO), and turn the ignition key to the Off position.

Set the parking brake when you leave the machine; refer to Setting the Parking Brake (page 16). Remember to remove the key from the ignition switch.

### **CAUTION**

**Children or bystanders may be injured if they move or attempt to operate the tractor while it is unattended.**

**Always remove the ignition key and set the parking brake when leaving the machine unattended, even if just for a few minutes.**

## Using the Rotation Indicator

The slots in the top of the belt covers allow the operator to verify if the blades have stopped rotating after disengaging the power take-off (PTO) switch.

Disengage the power take-off (PTO) switch, stop the engine, remove the key, and wait for all moving parts to stop before leaving the operating position.

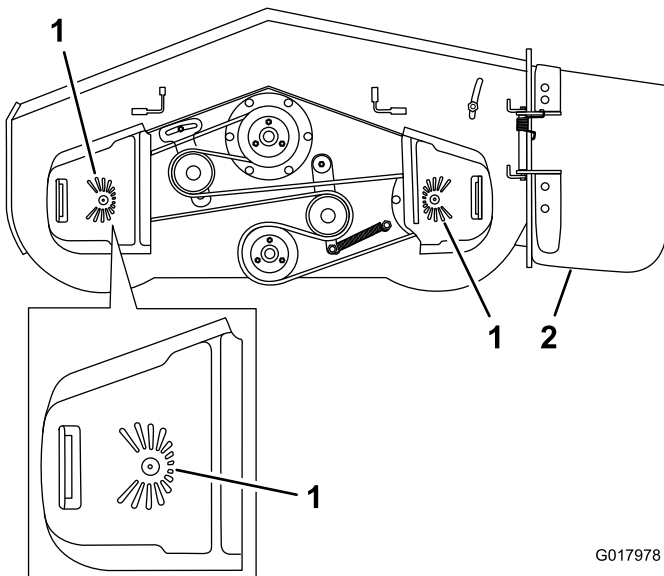

**Figure 21**

52-inch mower deck shown

1. Rotation Indicator—slots in the top of the belt cover
2. Side-discharge chute

## Pushing the Machine by Hand

The bypass valves allow the machine to be pushed by hand without the engine running.

**Important: Always push the machine by hand. Do not tow the machine, because hydraulic damage may occur.**

1. Disengage the PTO, move the motion-control levers to the neutral-locked position and set the parking brake.
2. Open the bypass valve on both pumps by turning them counterclockwise 1 to 2 turns. This allows hydraulic fluid to bypass the pumps and the wheels to turn (Figure 22).

**Note:** Rotate the bypass valves a maximum of 2 turns so the valve does not come out of the body causing fluid to run out.

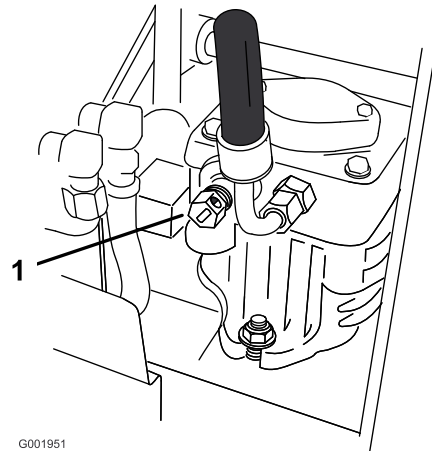

G001951

**Figure 22**

1. Pump-bypass valve

3. Release the parking brake.
4. Push the machine to the desired location.
5. Set the parking brake.
6. Close the bypass valves, but do not overtighten them. Torque to 12 to 15 N-m (9 to 11 ft-lb).

**Important: Do not start or operate the machine with the bypass valves open. Damage to system may occur.**

## Transporting the Machine

Use a heavy-duty trailer or truck to transport the machine. Ensure that the trailer or truck has all the necessary brakes, lighting, and marking as required by law. Please carefully read all the safety instructions.

To transport the machine:

1. Raise the platform of the machine before driving onto the trailer or truck.
2. If using a trailer, connect it to the towing vehicle and connect the safety chains.

3. If applicable, connect the trailer brakes.
4. Load the machine onto the trailer or truck.
5. Stop the engine, remove the key, set the brake, and close the fuel valve.
6. Use the metal tie-down loops on the machine to securely fasten the machine to the trailer or truck with straps, chains, cable, or ropes (Figure 23).

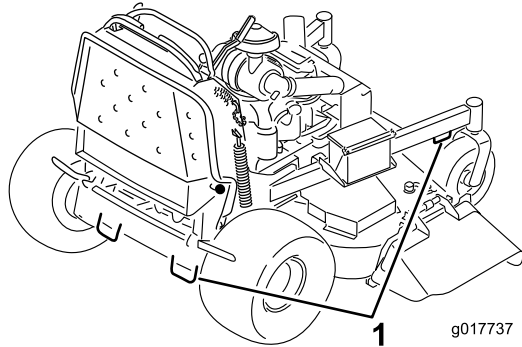

**Figure 23**

1. Traction unit tie-down loop

## Loading the Machine

Use extreme caution when loading units onto trailers or trucks. One full-width ramp that is wide enough to extend beyond the rear tires is recommended instead of individual ramps for each side of the unit (Figure 24). The platform when down and locked into position, extends back between the rear wheels and serves as a stop for tipping backward. Having a full-width ramp provides a surface for the platform to contact if the unit starts to tip backward. With the platform up, a full-width ramp provides a surface to walk on behind the unit. The operator should determine if it is best to have the platform up or down when loading, depending on conditions. If it is not possible to use one full-width ramp, use enough individual ramps to simulate a full-width, continuous ramp.

The ramp should be long enough so that the angles do not exceed 20 degrees (Figure 24). A steeper angle may cause mower components to get caught, as the unit moves from ramp to trailer or truck. Steeper angles may also cause the unit to tip backward. If loading on or near a slope, position the trailer or truck so it is on the down side of the slope and the ramp extends up the slope. This will minimize the ramp angle. The trailer or truck should be as level as possible.

**Important:** Do not attempt to turn the unit while on the ramp; you may lose control and drive off the side.

Avoid sudden acceleration when driving up a ramp and sudden deceleration when backing down a ramp. Both maneuvers can cause the unit to tip backward.

## ⚠ WARNING

Loading a unit onto a trailer or truck increases the possibility of backward tip-over, and could cause serious injury or death.

- Use extreme caution when operating a unit on a ramp.
- Use only a single, full-width ramp; do not use individual ramps for each side of the unit.
- If individual ramps must be used, use enough ramps to create an unbroken ramp surface wider than the unit.
- Do not exceed a 20-degree angle between ramp and ground, or between a ramp, a trailer, or a truck.
- Avoid sudden acceleration while driving unit up a ramp to avoid tipping backward.
- Avoid sudden deceleration while backing unit down a ramp to avoid tipping backward.

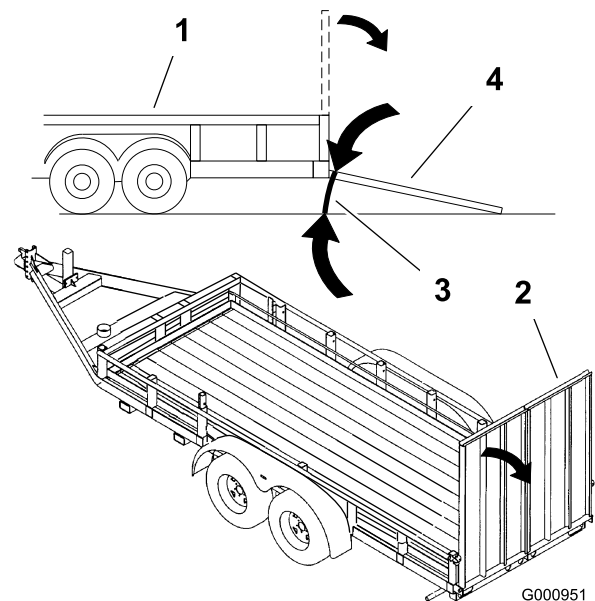

**Figure 24**

1. Trailer
2. Full-width ramp
3. Not greater than 20 degrees
4. Full-width ramp (side view)

## Side Discharging or Mulching the Grass

This mower has a hinged grass deflector that disperses clippings to the side and down toward the turf.

## ⚠ DANGER

Without the grass deflector, discharge cover, or complete grass catcher assembly mounted in place, you and others are exposed to blade contact and thrown debris. Contact with rotating mower blade(s) and thrown debris will cause injury or death.

- Do not remove the grass deflector from the mower, because the grass deflector routes material down toward the turf. If the grass deflector is ever damaged, replace it immediately.
- Never put your hands or feet under the mower.
- Never try to clear the discharge area or mower blades unless you release the bail and the power take off (PTO) is off. Rotate the ignition key to the Off position. Also remove the key and pull the wire(s) off the spark plug(s).

## Adjusting the Height-of-Cut

The height-of-cut can be adjusted from 25 to 127 mm (1 to 5 inches) in 6 mm (1/4 inches) increments.

1. Move the height-of-cut lever to the transport position (all the way up).
2. Select a hole in the height-of-cut bracket corresponding to the height-of-cut desired and, insert the pin (Figure 25).
3. Lower the height-of-cut lever to the pin (Figure 25).

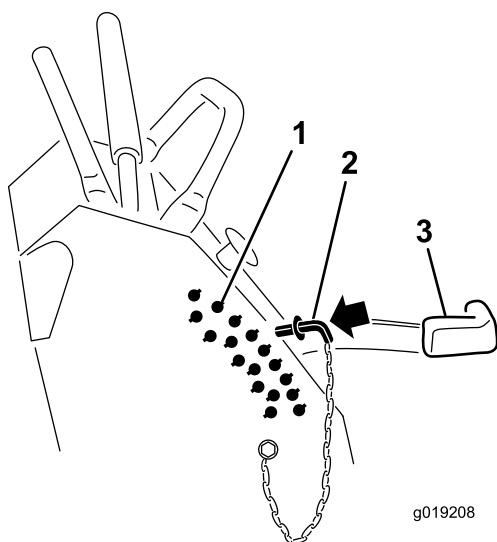

Figure 25

1. Height-of-cut holes
2. Height-of-cut pin
3. Height-of-cut lever

## Adjusting the Anti-scalp Rollers (for 60-inch models only)

Whenever you change the height-of-cut, it is recommended to adjust the height of the anti-scalp rollers.

1. Disengage the blade-control switch (PTO), move the motion-control levers to the neutral-locked position and set the parking brake.
2. Stop the engine, remove the key, and wait for all moving parts to stop before leaving the operating position.
3. Remove the nut and bolt position the anti-scalp rollers and install the nut and bolt.
4. Ensure the spacers and bushings are installed (Figure 26).

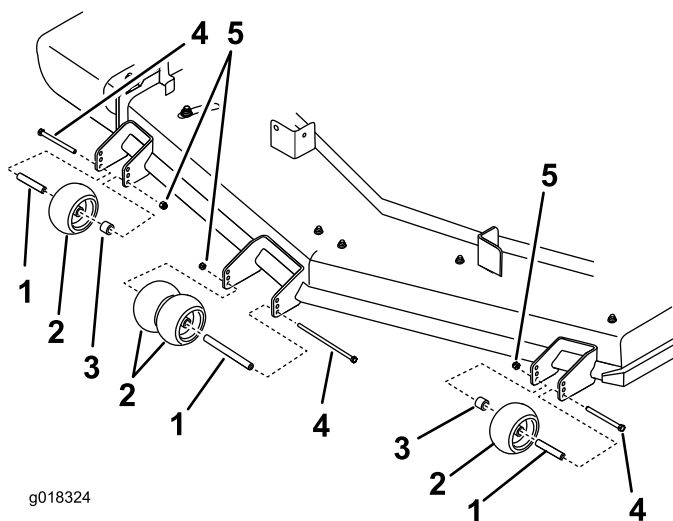

Figure 26

1. Bushing
2. Anti-scalp roller
3. Spacer
4. Bolt
5. Nut

## Adjusting the Flow Baffle

The mower-discharge flow can be adjusted for different types of mowing conditions. Position the cam lock and baffle to provide the best quality of cut.

1. Disengage the PTO, move the motion-control levers to the neutral-locked position, and set the parking brake.
2. Stop the engine, remove the key, and wait for all moving parts to stop before leaving the operating position.
3. To adjust the baffle, loosen the nut (Figure 27).
4. Adjust the baffle and nut in the slot to the desired discharge flow and tighten the nut.

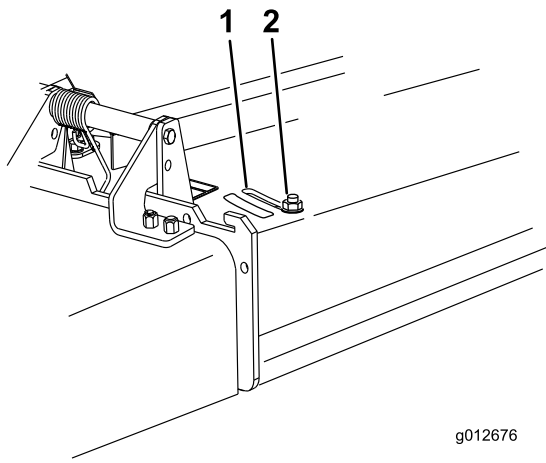

**Figure 27**

1. Slot                      2. Nut

g012676

## Position B

Use this position when bagging (Figure 29).

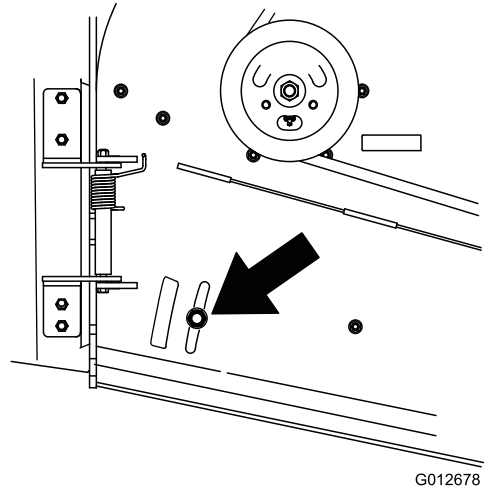

**Figure 29**

G012678

## Positioning the Flow Baffle

The following figures are only for recommended use. Adjustments will vary by grass type, moisture content, and the height of the grass.

**Note:** If the engine power draws down, and the mower ground speed is the same, open up the baffle.

### Position A

This is the full, rear position (see Figure 28). The suggested use for this position is as follows:

- In short, light grass mowing conditions
- In dry conditions
- Smaller grass clippings
- Propels grass clippings farther away from the mower

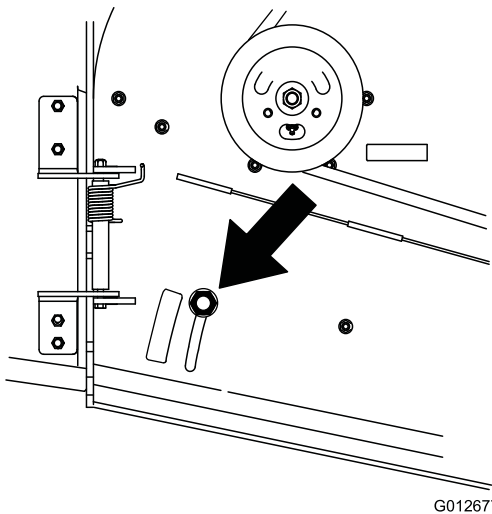

**Figure 28**

G012677

### Position C

This is the full, open position (Figure 30). The suggested use for this position is as follows:

- In tall, dense grass mowing conditions
- In wet conditions
- Lowers the engine-power consumption
- Allows increased ground speed in heavy conditions

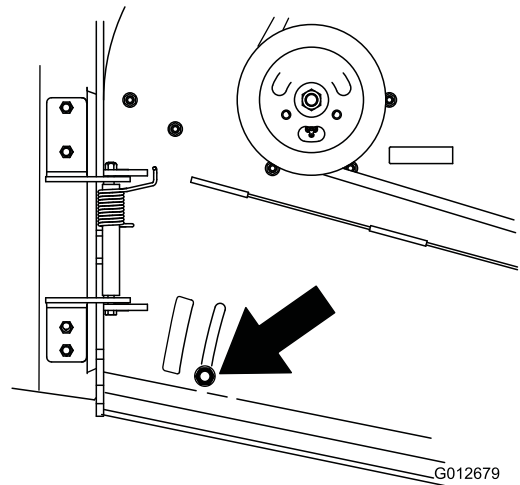

**Figure 30**

G012679

## Using the Mid-size Weight

- Weights are installed to improve handling, balance, and improve performance. Weights can be added or removed to create optimized performance under different mowing conditions and for operator preference.
- It is recommended that weights be added or removed one at a time until the desired handling and balance is achieved.

**Note:** Contact an Authorized Service Dealer to order a Weight Kit.

### **⚠ WARNING**

**Excessive weight changes can affect the handling and operation of the machine. This could cause serious injury to you or bystanders.**

**Make weight changes in small increments only.**

**Evaluate the mower after each weight change to ensure the machine can be operated safely.**

# Maintenance

**Note:** Determine the left and right sides of the machine from the normal operating position.

## Recommended Maintenance Schedule(s)

Maintenance Service Interval	Maintenance Procedure
After the first 8 hours	<ul style="list-style-type: none"> <li>• Check the hydraulic-fluid level.</li> <li>• Change the hydraulic filter.</li> </ul>
Before each use or daily	<ul style="list-style-type: none"> <li>• Check the safety-interlock system.</li> <li>• Check the engine-oil level.</li> <li>• Clean the air-intake screen.</li> <li>• Clean debris from the hydraulic-oil cooler (if equipped).</li> <li>• Check the brakes.</li> <li>• Inspect the blades.</li> <li>• Clean the mower deck.</li> </ul>
Every 50 hours	<ul style="list-style-type: none"> <li>• Grease the lift linkage (more often in dirty or dusty conditions).</li> <li>• Grease the mower deck spindles (more often in dirty or dusty conditions).</li> <li>• Check the spark arrester (if equipped).</li> <li>• Check the tire pressure.</li> <li>• Check the hydraulic-fluid level.</li> </ul>
Every 100 hours	<ul style="list-style-type: none"> <li>• Change the engine oil. (more often in dirty or dusty conditions)</li> <li>• Check the battery.</li> <li>• Check and clean the engine cooling fins and shrouds.</li> <li>• Service the hydraulic-oil cooler in dirty conditions (if equipped).</li> <li>• Check the mower-deck belt.</li> <li>• Check the pump-drive belt.</li> <li>• Check the hydraulic hoses.</li> </ul>
Every 150 hours	<ul style="list-style-type: none"> <li>• Inspect the primary filter and air-inlet screen.</li> </ul>
Every 200 hours	<ul style="list-style-type: none"> <li>• Change the engine-oil filter.</li> <li>• Check, clean and gap the spark plug.</li> <li>• Check the clutch.</li> <li>• Clean the engine-oil cooler.</li> </ul>
Every 250 hours	<ul style="list-style-type: none"> <li>• Change the hydraulic filter and hydraulic oil when using Mobil® 1 oil.</li> </ul>
Every 300 hours	<ul style="list-style-type: none"> <li>• Replace the primary air filter. (more often in dusty or sandy conditions)</li> <li>• Check the inner-air filter.</li> </ul>
Every 500 hours	<ul style="list-style-type: none"> <li>• Adjust the caster-pivot bearing.</li> <li>• Change the hydraulic filter and hydraulic oil when using Toro® HYPR-OIL™ 500 hydraulic oil.</li> </ul>
Every 600 hours	<ul style="list-style-type: none"> <li>• Replace the inner-air filter.</li> </ul>
Every 800 hours	<ul style="list-style-type: none"> <li>• Grease the front wheel bearings (more often in dirty or dusty conditions).</li> <li>• Grease the front caster pivots (more often in dirty or dusty conditions).</li> <li>• Replace the fuel filter.</li> </ul>
Before storage	<ul style="list-style-type: none"> <li>• Paint chipped surfaces.</li> <li>• Perform all maintenance procedures listed above before storage.</li> </ul>
Yearly	<ul style="list-style-type: none"> <li>• Grease the front caster pivots (more often in dirty or dusty conditions).</li> <li>• Lubricate the caster-wheel hubs.</li> </ul>

**Important:** Refer to your *Engine Operator's Manual* for additional maintenance procedures.

## ⚠ CAUTION

If you leave the key in the ignition switch, someone could accidentally start the engine and seriously injure you or other bystanders.

Remove the key from the ignition and disconnect the spark-plug wires from the spark plugs before you do any maintenance. Set the wires aside so that they do not accidentally contact the spark plugs.

# Premaintenance Procedures

## Raising the Mower for Access

The front of the mower can be raised and supported on its back for access under the machine for maintenance.

1. Raise the platform; refer to Operating the Platform (page 20).
2. Remove the battery.

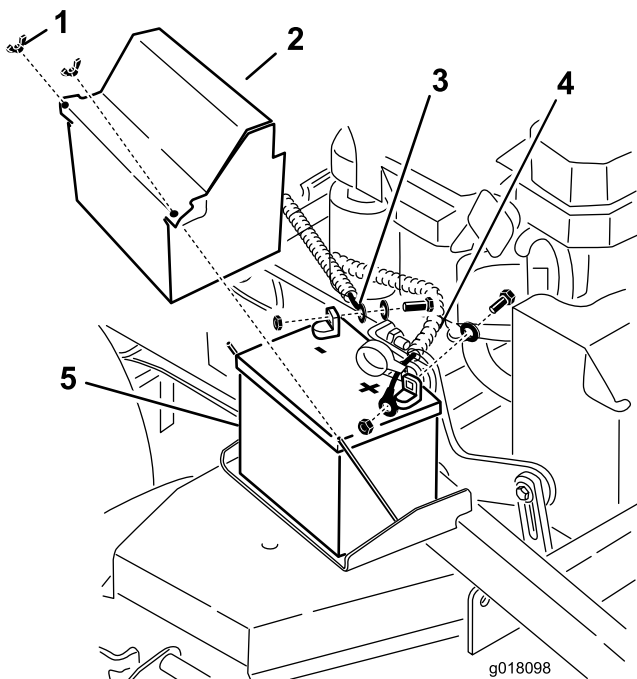

**Figure 31**

1. Wing nut
2. Battery cover
3. Negative-battery cable (-)
4. Positive-battery cable (+)
5. Battery

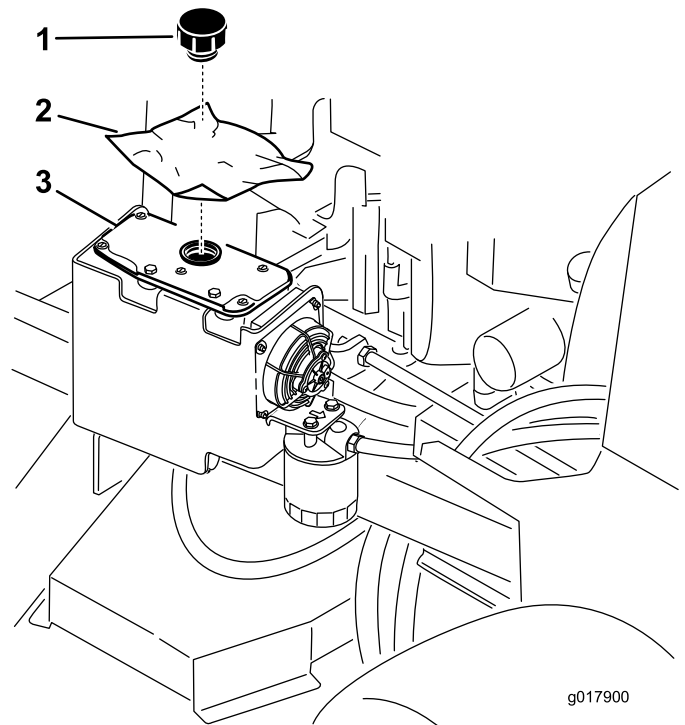

**Figure 32**

1. Cap
2. Piece of plastic
3. Hydraulic tank

5. With 2 people, raise the front of the mower so that it rests on the drive tires and the platform in the up position.
6. Perform any maintenance on the machine.
7. With 2 people, lower the front of the mower to the ground.
8. Remove the plastic under the hydraulic tank cap.
9. Install the battery for the machine.

3. Drain the fuel from the fuel tank; refer to Draining the Fuel Tank (page 36).
4. Remove the cap of the hydraulic tank, and place a piece of plastic over the opening and install the hydraulic cap.

**Note:** This will seal the hydraulic tank and prevent it from leaking out.

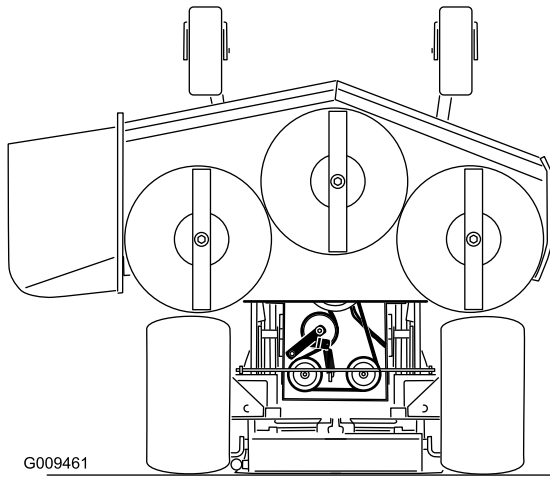
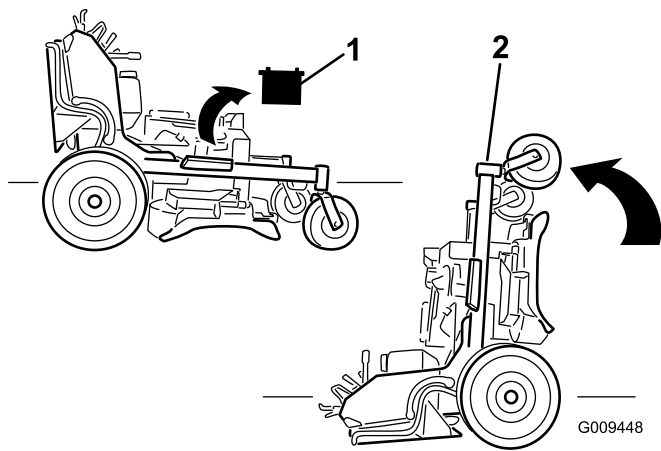

**Figure 33**

1. Remove battery
2. Front end of the mower

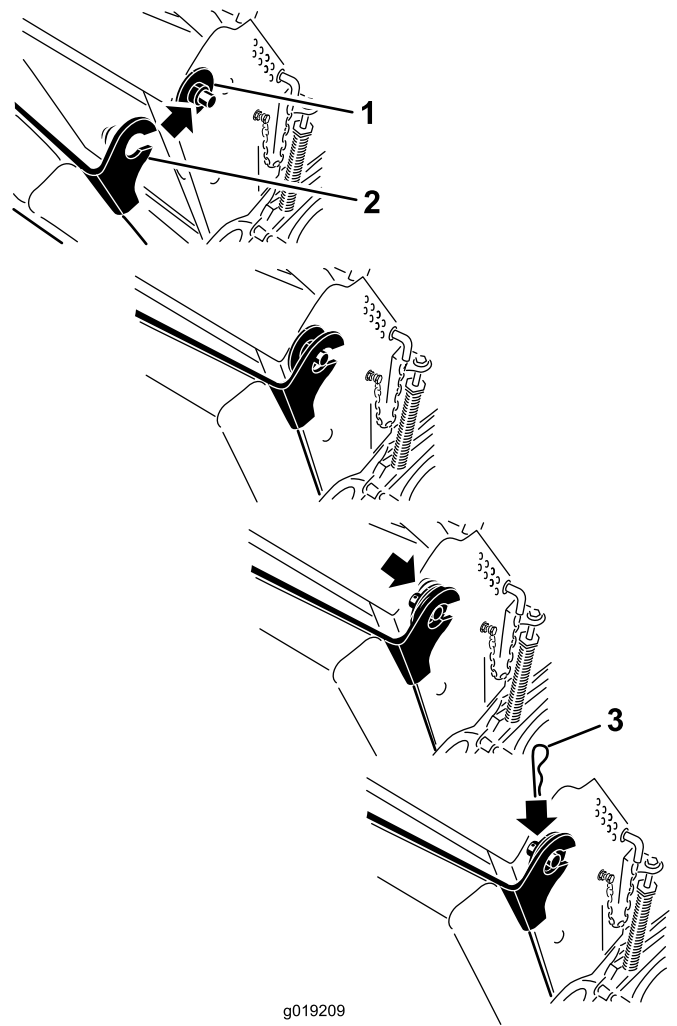

**Figure 34**

1. Plastic bushing with the large washer
2. Cushion bracket with the key hole
3. Hairpin-cotter pin

## Releasing the Cushion for Rear Access

You can release the cushion for rear access to the machine for maintenance or adjustment.

1. Lower the platform.
2. Remove the hairpin-cotter pins on each side of the cushion.
3. Slide the large washers with the plastic bushings to the inside.
4. Remove the cushion, and lower it to the platform.
5. Perform any maintenance or adjustment on the machine.
6. Raise the cushion and slide it onto the pins on both sides of the machine (Figure 34).
7. Slide the large washers with the plastic bushings into the cushion bracket, and secure them with a hairpin-cotter pin (Figure 34).

# Lubrication

Grease with No. 2 general purpose lithium base or molybdenum base grease.

## Lubricating the Machine

**Service Interval:** Every 50 hours—Grease the lift linkage (more often in dirty or dusty conditions).

Every 50 hours—Grease the mower deck spindles (more often in dirty or dusty conditions).

Every 800 hours/Yearly (whichever comes first)—Grease the front wheel bearings (more often in dirty or dusty conditions).

Every 800 hours/Yearly (whichever comes first)—Grease the front caster pivots (more often in dirty or dusty conditions).

Use the following graphics for locating the grease points.

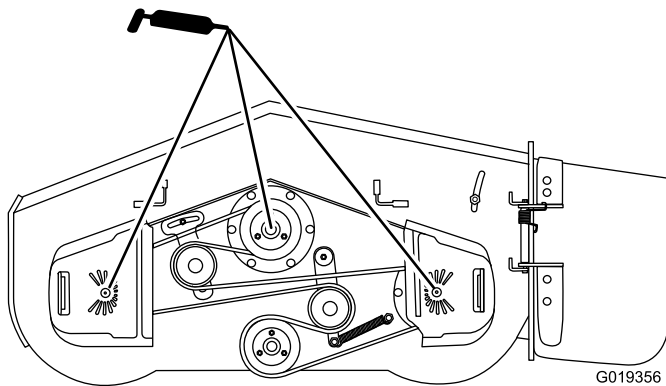

**Figure 35**

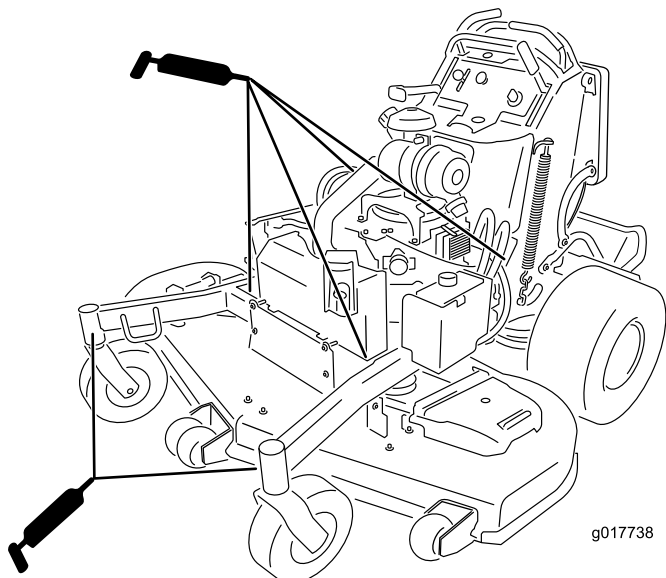

**Figure 36**

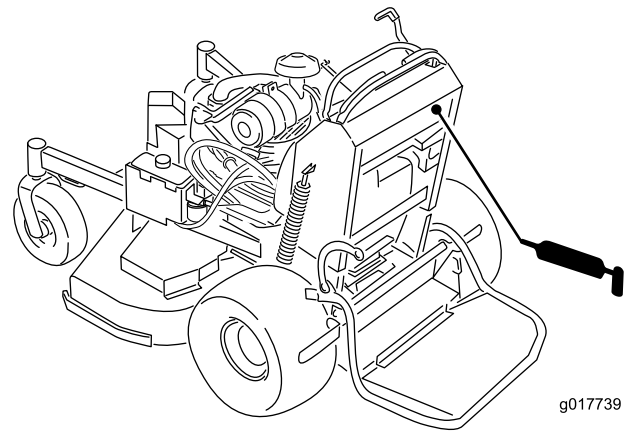

**Figure 37**

## Greasing the Front Caster Pivots

**Service Interval:** Yearly

Lubricate the front caster pivots once a year.

1. Remove the dust cap and adjust the caster pivots; refer to Adjusting the Caster-pivot Bearing (page 42).

**Note:** Keep the dust cap off until greasing is done.

2. Remove the hex plug.
3. Thread a grease fitting into the hole.
4. Pump grease into the fitting until it oozes out around the top bearing.
5. Remove the grease fitting in the hole. Install the hex plug and cap.

# Lubricate Caster-wheel Hubs

**Service Interval:** Yearly

1. Stop the engine, wait for all moving parts to stop, engage the parking brake, and remove the key.

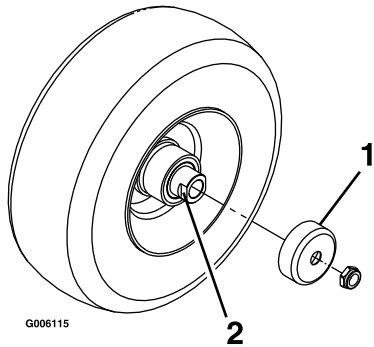

**Figure 38**

1. Seal guard
2. Spacer nut with wrench flats

2. Remove the caster wheel from the caster forks.
3. Remove the seal guards from the wheel hub.
4. Remove one of the spacer nuts from the axle assembly in the caster wheel.

**Note:** Thread-locking adhesive has been applied to lock the spacer nuts to the axle. Remove the axle (with the other spacer nut still assembled to it) from the wheel assembly.

5. Pry out the seals and inspect bearings for wear or damage, and replace if necessary.
6. Pack the bearings with a general-purpose grease.
7. Insert 1 bearing and 1 seal into the wheel.

**Note:** The seals must be replaced.

8. If the axle assembly has had both spacer nuts removed (or broken loose), apply a thread-locking adhesive to one spacer nut and thread it onto the axle with the wrench flats facing outward.

**Note:** Do Not thread spacer nut all of the way onto the end of the axle. Leave approximately 3 mm (1/8 inch) from the outer surface of the spacer nut to the end of the axle inside the nut.

9. Insert the assembled nut and axle into the wheel on the side of the wheel with the new seal and bearing.
10. With the open end of the wheel facing up, fill the area inside the wheel around the axle full of general-purpose grease.
11. Insert the second bearing and the new seal into the wheel.
12. Apply a thread-locking adhesive to the second spacer nut, and thread it onto the axle with the wrench flats facing outward.

13. Torque the nut to 8 to 9 N-m (71 to 80 in-lb), loosen, then torque it to 2 to 3 N-m (20 to 25 in-lb).

**Note:** Make sure axle does not extend beyond either nut.

14. Install the seal guards over the wheel hub and insert wheel into caster fork.
15. Install caster bolt and tighten nut fully.

**Important:** To prevent seal and bearing damage, check the bearing adjustment often by spinning the caster tire. The tire should not spin freely (more than 1 or 2 revolutions) or have any side play. If the wheel spins freely, adjust the torque on the spacer nut until there is a slight amount of drag, and apply thread-locking adhesive.

# Engine Maintenance

## Servicing the Air Cleaner

**Service Interval:** Every 150 hours

Every 300 hours/Yearly (whichever comes first)—Replace the primary air filter. (more often in dusty or sandy conditions)

Every 300 hours—Check the inner-air filter.

Every 600 hours—Replace the inner-air filter.

**Note:** Check the filters more frequently if the operating conditions are extremely dusty or sandy.

### Removing the Filters

1. Disengage the PTO, move the motion-control levers to the neutral-locked position, and set the parking brake.
2. Stop the engine, remove the key, and wait for all moving parts to stop before leaving the operating position.
3. Release the latches on the air cleaner and pull the air-cleaner cover off the air-cleaner body (Figure 39).
4. Clean the inside of the air-cleaner cover with compressed air.
5. Gently slide the primary filter out of the air-cleaner body (Figure 39).

**Note:** Avoid knocking the filter into the side of the body.

6. Remove the inner filter only if you intend to replace it.

**Important:** Never attempt to clean the inner filter. If the safety filter is dirty, then the primary filter is damaged. Replace both filters.

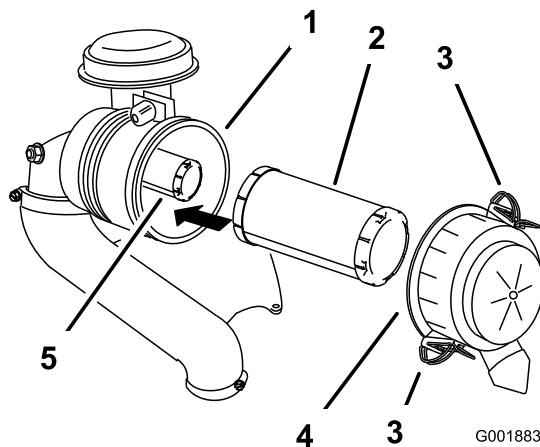

**Figure 39**

- |                     |                      |
|---------------------|----------------------|
| 1. Air-cleaner body | 4. Air-cleaner cover |
| 2. Primary filter   | 5. Inner filter      |
| 3. Latch            |                      |

7. Inspect the primary filter for damage by looking into the filter while shining a bright light on the outside of the filter.

**Note:** Holes in the filter will appear as bright spots.

**Note:** If the filter is damaged, discard it.

### Servicing the Primary Filter

- If the primary filter is dirty, bent, or damaged, replace it.
- Do not clean the primary filter.

### Servicing the Safety Filter

Replace the safety filter, never clean it.

**Important:** Never attempt to clean the safety filter. If the safety filter is dirty, then the primary filter is damaged. Replace both filters.

### Installing the Filters

**Important:** To prevent engine damage, always operate the engine with both air filters and cover installed.

1. If installing new filters, check each filter for shipping damage.  
**Note:** Do not use a damaged filter.
2. If the safety filter is being replaced, carefully slide it into the filter body (Figure 39).
3. Carefully slide the primary filter over the safety filter (Figure 39).

**Note:** Ensure that the primary filter is fully seated by pushing on its outer rim while installing it.

**Important:** Do not press on the soft, inside area of the filter.

4. Install the air-cleaner cover and secure the latches (Figure 39).

# Servicing the Engine Oil

**Oil Type:** Detergent oil (API service class SJ or higher)

**Oil Capacity:** with a filter change, 1.9 L (61 oz); with no filter change, 1.6 L (54 oz)

**Viscosity:** See the table below.

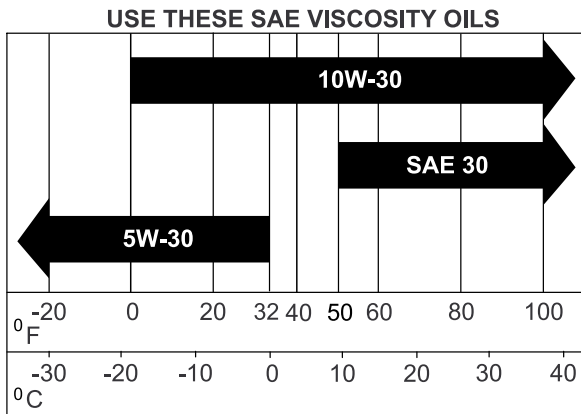

Figure 40

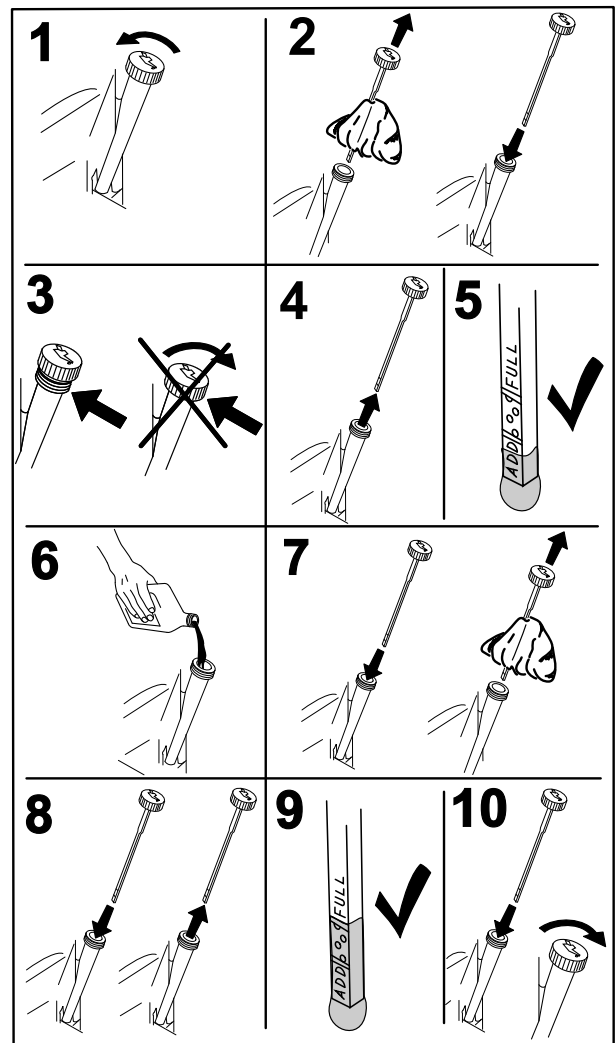

Figure 41

## Checking the Engine-oil Level

**Service Interval:** Before each use or daily

**Note:** Check the oil when the engine is cold.

### ⚠ WARNING

Contact with hot surfaces may cause personal injury.

Keep hands, feet, face, clothing and other body parts away from the muffler and other hot surfaces.

**Important:** Do not overfill the crankcase with oil, because damage to the engine may result. Do not run engine with oil below the Low mark, because the engine may be damaged.

1. Disengage the PTO, move the motion-control levers to the neutral-locked position, and set the parking brake.
2. Stop the engine, remove the key, and wait for all moving parts to stop before leaving the operating position (Figure 41).

# Changing the Engine Oil

**Service Interval:** Every 100 hours (more often in dirty or dusty conditions)

**Note:** Dispose of the used oil at a recycling center.

1. Park the machine so that the rear is slightly lower than the front to ensure the oil drains completely.
2. Disengage the PTO, move the motion-control levers to the neutral-locked position and set the parking brake.
3. Stop the engine, remove the key, and wait for all moving parts to stop before leaving the operating position (Figure 42).

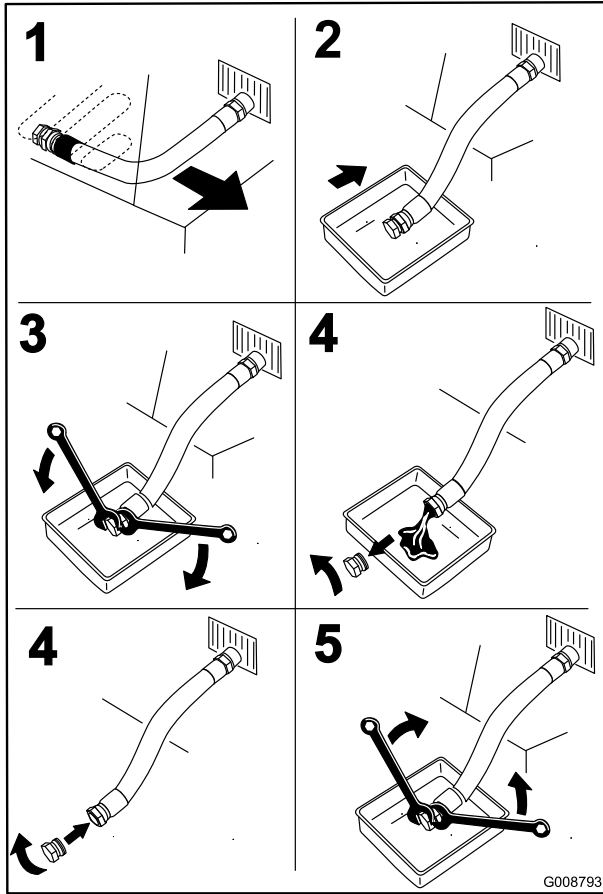

Figure 42

4. Slowly pour approximately 80% of the specified oil into the filler tube and slowly add the additional oil to bring it to the **Full** mark (Figure 43).

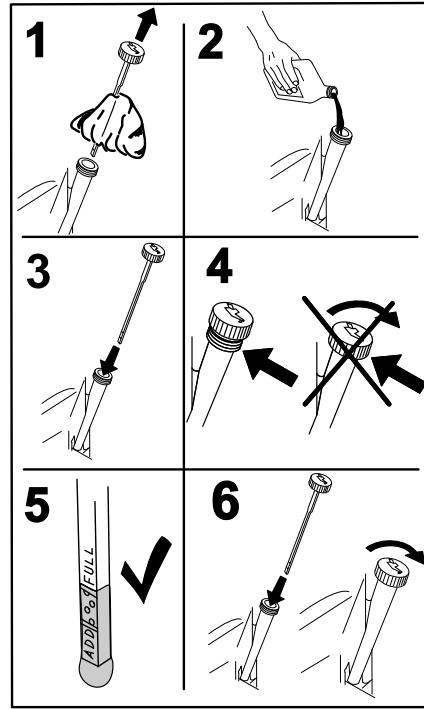

Figure 43

5. Start the engine and drive to a flat area.
6. Check the oil level again.

## Changing the Engine-oil Filter

**Service Interval:** Every 200 hours

**Note:** Change the engine-oil filter more frequently when operating conditions are extremely dusty or sandy.

1. Drain the oil from the engine; refer to Changing the Engine Oil (page 34).
2. Place a rag under the oil filter to soak up any spilled oil.

**Important:** Spilled oil may drain under the engine and onto the clutch. Oil spilled on the clutch may damage the clutch, cause the blades to stop slowly when the clutch is in the Off position, and cause the clutch to slip when the clutch is switched to the On position. Wipe up any spilled oil.

3. Change the engine-oil filter (Figure 44).

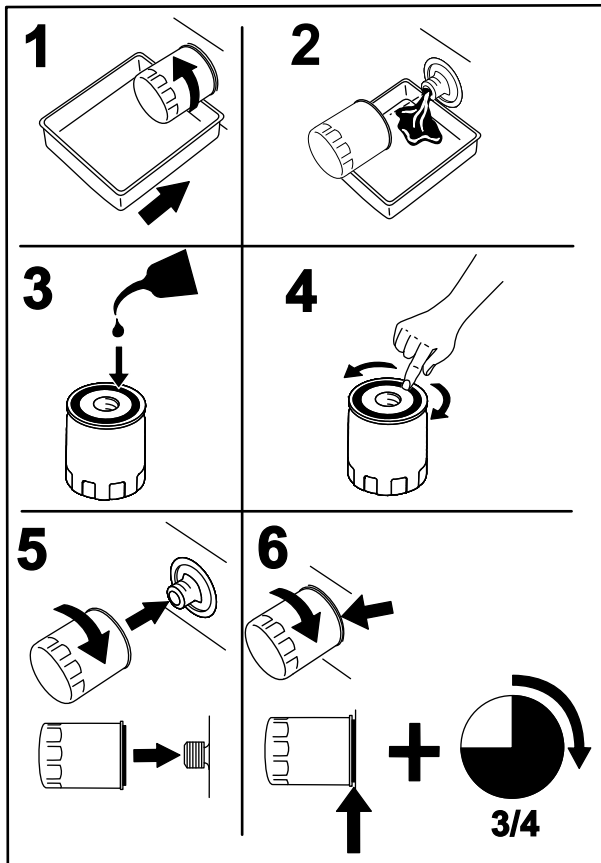

Figure 44

G008748

**Note:** Ensure that the oil-filter gasket touches the engine, and then an extra 3/4 turn is completed.

4. Fill the crankcase with the proper type of new oil; refer to Changing the Engine Oil (page 34).

## Servicing the Spark Plug

**Service Interval:** Every 200 hours

Make sure the air gap between the center and side electrodes is correct before installing the spark plug.

Use a spark plug wrench for removing and installing the spark plug(s) and a gapping tool/feeler gauge to check and adjust the air gap. Install a new spark plug(s) if necessary.

**Type for all Engines:** Kohler 25 132 14-c Champion XC12YC or equivalent

**Air Gap:** 0.75 mm (0.03 inch)

## Removing the Spark Plug

1. Disengage the PTO, move the motion-control levers to the neutral-locked position, and set the parking brake.
2. Stop the engine, remove the key, and wait for all moving parts to stop before leaving the operating position.
3. Remove the spark plug as shown in Figure 45.

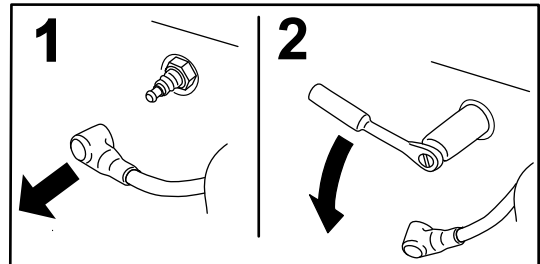

Figure 45

G008791

## Checking the Spark Plug

**Important:** Do not clean the spark plug(s). Always replace the spark plug(s) when it has a black coating, worn electrodes, an oily film, or cracks.

If you see light brown or gray on the insulator, the engine is operating properly. A black coating on the insulator usually means the air cleaner is dirty.

Set the gap to 0.75 mm (0.03 inch).

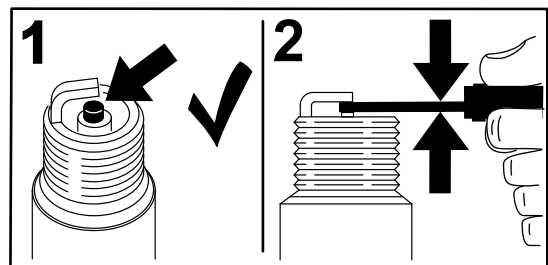

Figure 46

G008794

## Installing the Spark Plug

Tighten the spark plug(s) to 22 N-m (16 ft-lb).

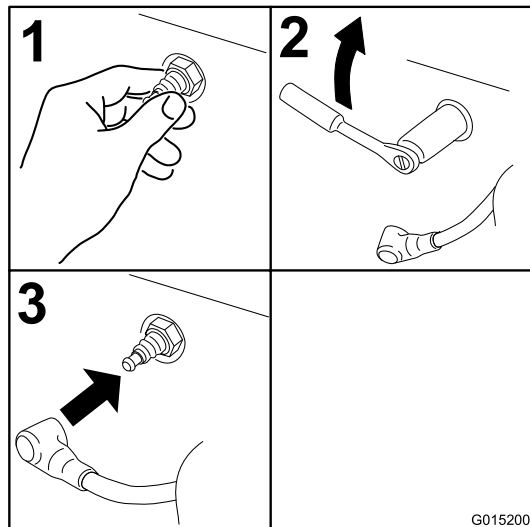

Figure 47

## Checking the Spark Arrester (if equipped)

Service Interval: Every 50 hours

### **⚠ WARNING**

Hot exhaust-system components may ignite gasoline vapors even after the engine is stopped. Hot particles exhausted during engine operation may ignite flammable materials. Fire may result in personal injury or property damage.

Do not refuel or run the engine unless the spark arrester is installed.

1. Stop the engine, wait for all moving parts to stop, engage the parking brake, and remove the key.
2. Wait for the muffler to cool.
3. If any breaks in the screen or welds are observed, replace the arrester.
4. If plugging of the screen is observed, remove the arrester, shake loose particles out of the arrester, and clean the screen with a wire brush (soak in solvent if necessary).
5. Install arrester on exhaust outlet.

## Fuel System Maintenance

### Draining the Fuel Tank

**Note:** There is no other recommended way to drain fuel from the tank, other than using a syphon pump. A syphon pump can be purchased at a hardware store.

### **⚠ DANGER**

In certain conditions, gasoline is extremely flammable and highly explosive. A fire or explosion from gasoline can burn you and others and can damage property.

- Drain gasoline from the fuel tank when the engine is cold. Do this outdoors in an open area. Wipe up any gasoline that spills.
  - Never smoke when draining gasoline, and stay away from an open flame, or where a spark may ignite the gasoline fumes.
1. Disengage the PTO, move the motion-control levers to the neutral-locked position, and set the parking brake.
  2. Stop the engine, remove the key, and wait for all moving parts to stop before leaving the operating position
  3. Clean around the fuel cap to prevent debris from getting into the fuel tank (Figure 49).
  4. Remove the fuel cap.
  5. Insert a syphon pump into the fuel tank.
  6. Using the syphon pump, drain the fuel into a clean gas can (Figure 48).
  7. Wipe up any spilled fuel.

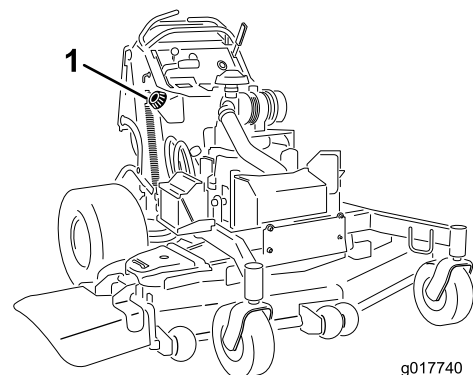

Figure 48

1. Fuel cap

# Servicing the Fuel Filter

## Replacing the Fuel Filter

**Service Interval:** Every 800 hours/Yearly (whichever comes first)

Do not install a dirty filter if it is removed from the fuel line.

**Note:** Wipe up any spilled fuel.

1. Disengage the PTO and set the parking brake.
2. Stop the engine, remove the key, and wait for all moving parts to stop before leaving the operating position.
3. Close the fuel shut-off valve (behind the operator cushion).
4. Squeeze the ends of the hose clamps together and slide them away from the filter (Figure 49).

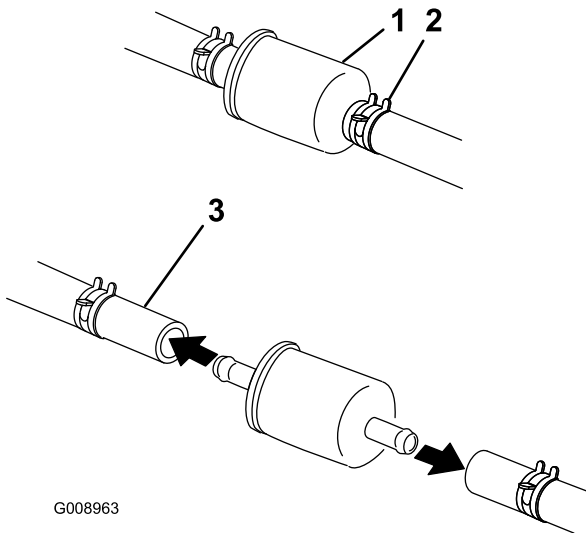

**Figure 49**

1. Filter
2. Hose clamp
3. Fuel line

- 
5. Remove the filter from the fuel lines.
  6. Install a new filter and move the hose clamps close to the filter.
  7. Open the fuel shut-off valve.
  8. Check for fuel leaks and repair if needed.
  9. Wipe up any spilled fuel.

# Servicing the Electronic Fuel-injection System

This machine contains an electronic fuel-injection system. It controls the fuel flow under different operating conditions.

The electronic-control unit (ECU) continuously monitors the operation of the EFI system.

If a problem or fault within the system is detected, the malfunction-indicator light (MIL) is illuminated. The MIL is the red light located in the console panel.

Once the MIL illuminates, initial trouble shooting checks should be made.

If these checks do not correct the problem, further diagnosis and servicing by an Authorized Service Dealer is necessary.

# Electrical System Maintenance

## Servicing the Battery

Service Interval: Every 100 hours

Always keep the battery clean and fully charged. Use a paper towel to clean the battery case. If the battery terminals are corroded, clean them with a solution of four parts water and one part baking soda. Apply a light coating of grease to the battery terminals to prevent corrosion.

Voltage: 12 V

### ⚠ WARNING

#### CALIFORNIA Proposition 65 Warning

Battery posts, terminals, and related accessories contain lead and lead compounds, chemicals known to the State of California to cause cancer and reproductive harm. Wash hands after handling.

### ⚠ DANGER

Do not drink electrolyte, and avoid contact with skin, eyes or clothing. Wear safety glasses to shield your eyes and rubber gloves to protect your hands.

Battery electrolyte contains sulfuric acid which is a deadly poison and causes severe burns.

## Removing the Battery

### ⚠ WARNING

Battery terminals or metal tools could short against metal machine components causing sparks. Sparks can cause the battery gasses to explode, resulting in personal injury.

- When removing or installing the battery, do not allow the battery terminals to touch any metal parts of the machine.
- Do not allow metal tools to short between the battery terminals and metal parts of the machine.

### ⚠ WARNING

Incorrect battery-cable routing could damage the machine and cables causing sparks. Sparks can cause the battery gasses to explode, resulting in personal injury.

- Always disconnect the negative (black) battery cable before disconnecting the positive (red) cable.
  - Always connect the positive (red) battery cable before connecting the negative (black) cable.
1. Disengage the PTO and set the parking brake.
  2. Stop the engine, remove the key, and wait for all moving parts to stop before leaving the operating position.
  3. Lift the black, rubber cover on the negative cable.
  4. Disconnect the negative battery cable from the negative (-) battery terminal (Figure 50).

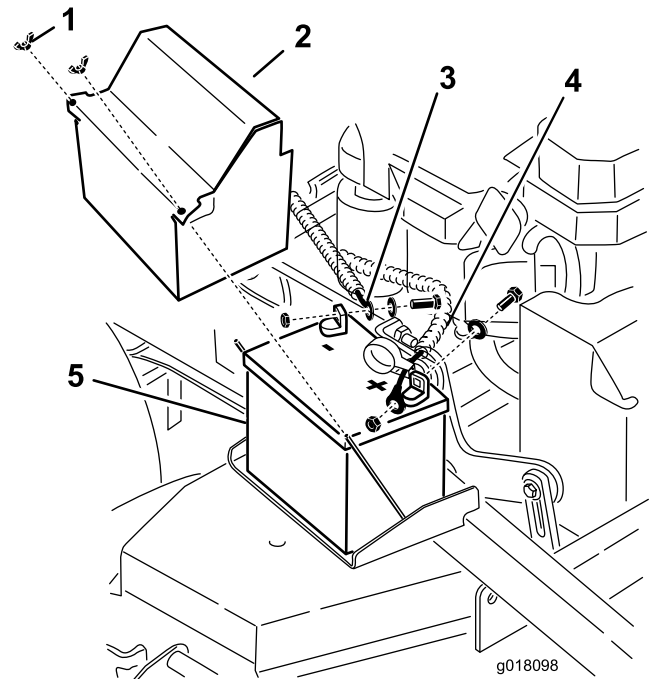

Figure 50

1. Wing nut
2. Battery cover
3. Negative battery cable
4. Positive battery cable
5. Battery

5. Slide the red terminal boot off the positive (red) battery terminal.
6. Remove the positive (red) battery cable (Figure 50).
7. Remove the battery hold down plate (Figure 50), and remove the battery.

## Installing the Battery

1. Place the battery onto the machine (Figure 50).
2. Secure the battery with the hold down plate, j-bolts, and locknuts.
3. Install the positive (red) battery cable to positive (+) battery terminal with a nut, a washer, and a bolt (Figure 50).
4. Slide the rubber cover over the post.
5. Install the negative battery cable and the ground wire to the negative (-) battery terminal with a nut, a washer, and a bolt (Figure 50).
6. Slide the rubber cover over the post.

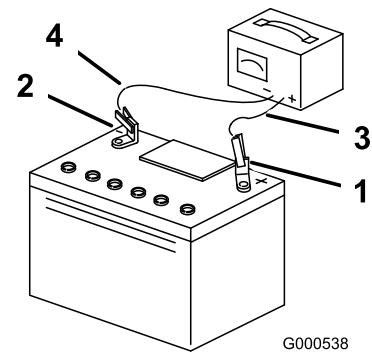

**Figure 51**

- |                          |                           |
|--------------------------|---------------------------|
| 1. Positive Battery Post | 3. Red (+) Charger Lead   |
| 2. Negative Battery Post | 4. Black (-) Charger Lead |

## Charging the Battery

### **⚠ WARNING**

Charging the battery produces gasses that can explode.

Never smoke near the battery and keep sparks and flames away from battery.

**Important:** Always keep the battery fully charged (1.265 specific gravity) to prevent battery damage when the temperature is below 32°F (0°C).

1. Remove the battery from the chassis; refer to Removing the Battery (page 38).
2. Check the electrolyte level.
3. Ensure that the filler caps are installed on the battery.
4. Charge the battery for 1 hour at 25 to 30 amps or 6 hours at 4 to 6 amps.
5. When the battery is fully charged, unplug the charger from the electrical outlet, and disconnect the charger leads from the battery posts (Figure 51).
6. Install the battery onto the machine and connect the battery cables; refer to Installing the Battery (page 39).

**Note:** Do not run the machine with the battery disconnected; electrical damage may occur.

## Servicing the Fuses

The electrical system is protected by fuses, and requires no maintenance. If a fuse blows, check the component or circuit for a malfunction or short.

1. Release the cushion from the rear of the machine.
2. Pull out on the fuse to remove or replace it (Figure 52).
3. Install the cushion to the rear of the machine.

**Note:** Ensure that the correct-size fuse is installed (Figure 52).

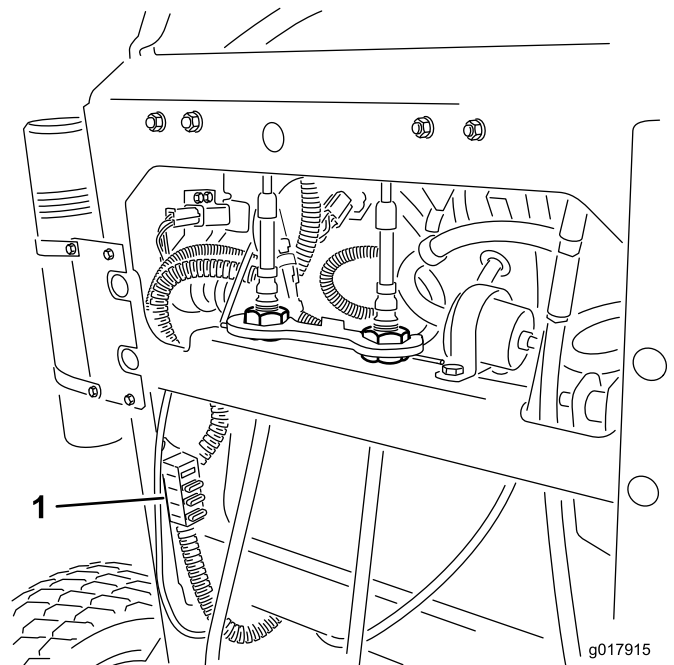

**Figure 52**

1. Fuses

# Jump Starting the Machine

1. Check and clean corrosion from the battery terminals before jump starting the machine. Ensure that the connections are tight.

## ⚠ CAUTION

Corrosion or loose connections can cause unwanted electrical voltage spikes at anytime during the jump starting procedure.

Do not attempt to jump start with loose or corroded battery terminals or damage to the engine or EFI may occur.

## ⚠ DANGER

Jump starting a weak battery that is cracked, frozen, has low electrolyte level, or an open/shorted battery cell, can cause an explosion resulting in serious personal injury.

Do not jump start a weak battery if these conditions exist.

2. Make sure that the booster battery is a good and fully charged lead-acid battery at 12.6 volts or greater. Use proper sized jumper cables with short lengths to reduce voltage drop between systems.
3. Make sure that the cables are color coded or labeled for the correct polarity.

## ⚠ CAUTION

Connecting the jumper cables incorrectly (wrong polarity) can immediately damage the EFI system.

Be certain of battery terminal polarity and jumper cable polarity when hooking up batteries.

## ⚠ WARNING

Batteries contain acid and produce explosive gases.

- Shield you eyes and face from the batteries at all times.
- Do not lean over the batteries.

**Note:** Be sure that the vent caps are tight and level. Place a damp cloth, if available, over any vent caps on both batteries. Be sure that the vehicles do not touch and that both of the electrical systems are off and at the

same rated system voltage. These instructions are for negative ground systems only.

4. Connect the positive (+) cable to the positive (+) terminal of the discharged battery that is wired to the starter or solenoid as shown in Figure 53.

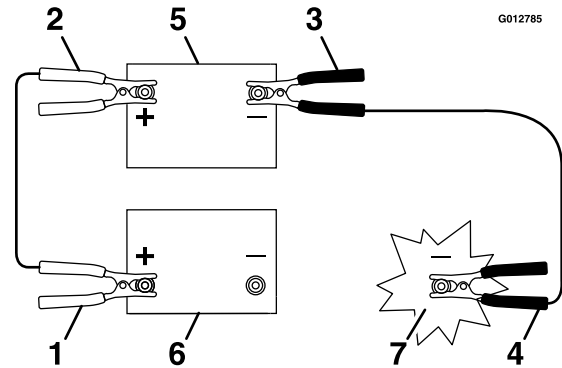

Figure 53

- |  |                       |
|--|-----------------------|
| 1. Positive (+) cable on discharged battery  | 5. Booster battery    |
| 2. Positive (+) cable on booster battery     | 6. Discharged battery |
| 3. Negative (-) cable on the booster battery | 7. Engine block       |
| 4. Negative (-) cable on the engine block    |                       |

5. Connect the other end of the positive cable to the positive terminal of the booster battery.
6. Connect the black negative (-) cable to the other terminal (negative) of the booster battery.
7. **Make the final connection on the engine block of the stalled vehicle (not to the negative battery post) away from the battery and stand back (Figure 54).**

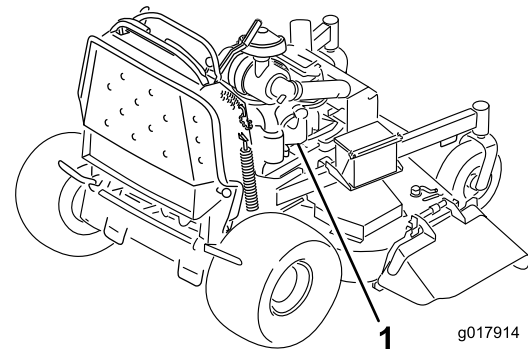

Figure 54

1. Engine block
8. Start the vehicle, and remove the cables in the reverse order of connection (the engine block (black) connection is the first to disconnect).

# Drive System Maintenance

## Adjusting the Tracking

**Note:** Determine the left and right sides of the machine from the normal operating position.

1. Push both control levers forward the same distance.
2. Check if the machine pulls to one side.

**Note:** If it does, stop the machine and set the parking brake.

3. Release the cushion from the rear of the machine.
4. Rotate the right cable adjustment to position the right motion control in the center of the control panel neutral-lock slot (Figure 56).

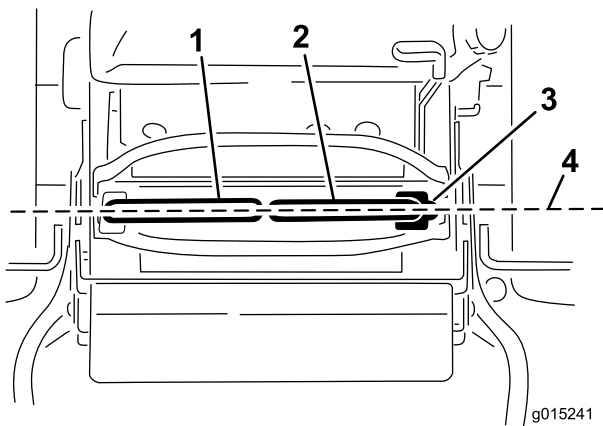
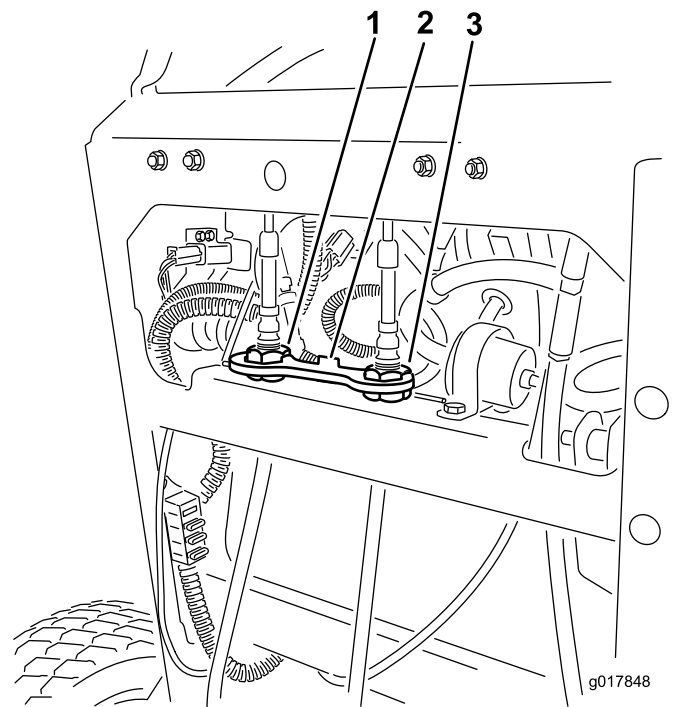

**Figure 55**

- |                               |   |
|-------------------------------|---|
| 1. Left motion-control lever  | 3. Neutral-locked position                |
| 2. Right motion-control lever | 4. Align the control levers front to back |

5. Rotate the left cable adjustment to match the left wheel speed to the previously set right wheel speed.
6. Adjust in quarter-turn increments until the machine tracks straight.

**Note:** Only adjust the left cable to match the left wheel speed to the right wheel speed. Do not adjust the right wheel speed as this will position the right motion-control lever out of the center for the control panel neutral-lock slot.



**Figure 56**

- |                          |                           |
|--------------------------|---------------------------|
| 1. Left cable adjustment | 3. Right cable adjustment |
| 2. Cable lock            |                           |

7. Check for proper tracking.

**Note:** If the machine will not start after adjusting the tracking, make sure proximity switch target aligns with bolt attached to motion-control lever; refer to Adjusting the Proximity Switch (page 41).

8. Repeat the cable adjustment until the tracking is correct.
9. Check that the machine does not creep from neutral with the park brakes disengaged.

**Important:** Do not rotate the linkage too far, as this may cause the machine to creep in neutral.

## Adjusting the Proximity Switch

Use this procedure if the machine will not start after adjusting the tracking.

1. Ensure that the bolt attached to the motion-control lever aligns with the proximity switch target (Figure 57).
2. If needed, loosen the bolts and adjust the proximity switch until the target aligns with the bolt attached to the motion-control lever (Figure 57).
3. Check the distance of the bolt to the proximity switch; it needs to be between 0.51 to 1.02 mm (0.02 to 0.04 inches) as shown in Figure 57.
4. If adjustment is needed, loosen the jam nut and adjust the bolt to the correct distance.
5. Tighten the jam nut after adjusting the bolt (Figure 57).
6. Test the safety-interlock system before operation.

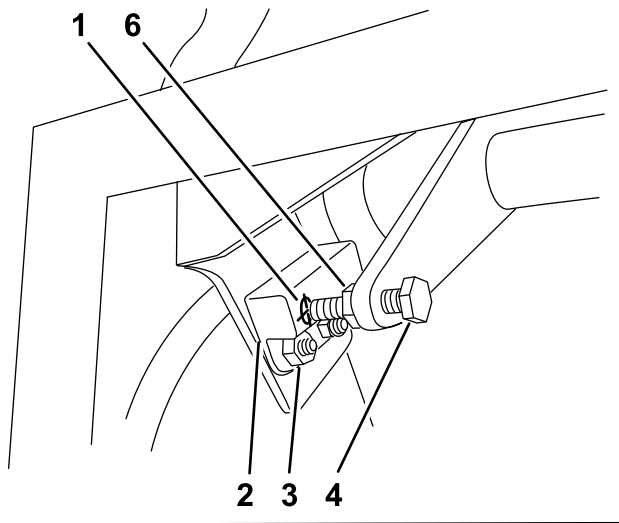

Figure 57

G015609

- |                            |   |
|----------------------------|---|
| 1. Proximity switch target | 4. Bolt attached to the motion-control lever                        |
| 2. Proximity switch        | 5. Distance between 0.51 to 1.02 mm (0.02 to 0.04 inches) is needed |
| 3. Bolts and nuts          | 6. Jam nut  |

## Checking the Tire Pressure

**Service Interval:** Every 50 hours/Monthly (whichever comes first)

Maintain the air pressure in the rear tires at 83 to 97 kPa (12 to 14 psi).

**Important:** Uneven tire pressure can cause an uneven cut.

**Note:** The front tires are semi-pneumatic tires and do not require air-pressure maintenance.

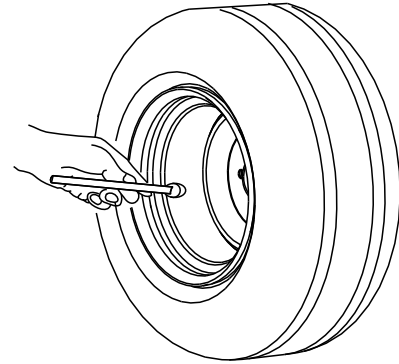

G001055

Figure 58

## Adjusting the Caster-pivot Bearing

**Service Interval:** Every 500 hours/Yearly (whichever comes first)

1. Disengage the blade-control switch (PTO), move the motion control levers to the neutral-locked position, and set the parking brake.
2. Stop the engine, remove the key, and wait for all moving parts to stop before leaving the operating position.
3. Remove the dust cap from the caster and tighten the lock nut (Figure 59).
4. Tighten the locknut until the spring washers are flat, and then back off a 1/4 turn to properly set the preload on the bearings (Figure 59).
5. Install the dust cap (Figure 59).

**Important:** Make sure spring washers are installed correctly as shown in Figure 59.

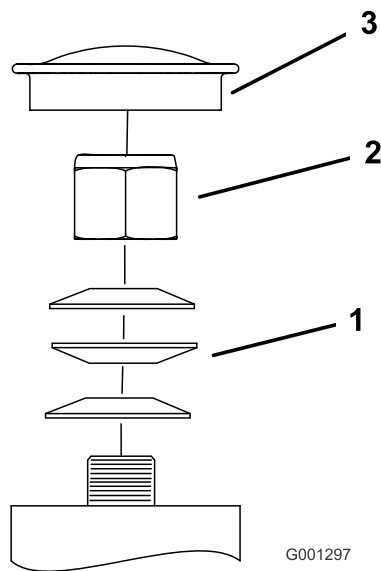

**Figure 59**

- |                   |             |
|-------------------|-------------|
| 1. Spring washers | 3. Dust cap |
| 2. Locknut        |             |

2. Remove one bushing, then pull the spanner bushing and roller bearing out of the wheel hub (Figure 60).
3. Remove the other bushing from the wheel hub, and clean any grease and dirt from the wheel hub (Figure 60).
4. Inspect the roller bearing, bushings, spanner bushing and the inside of the wheel hub for wear.
 

**Note:** Replace any defective or worn parts (Figure 60).
5. Place one bushing into the wheel hub (Figure 60).
6. Grease the roller bearing and spanner bushing, and slide them into the wheel hub (Figure 60).
7. Place the second bushing into the wheel hub (Figure 60).
8. Install the caster wheel into the caster fork and secure it with the wheel bolt and locknut (Figure 60).
9. Tighten the locknut until the spanner bushing bottoms against the inside of the caster forks (Figure 60).
10. Grease the fitting on the caster wheel.

## Servicing the Caster Wheels and Bearings

The caster wheels rotate on a roller bearing supported by a spanner bushing. If the bearing is kept well lubricated, wear will be minimal. Failure to keep the bearing well lubricated will cause rapid wear. A wobbly caster wheel usually indicates a worn bearing.

1. Remove the locknut and wheel bolt holding the caster wheel to the caster fork (Figure 60).

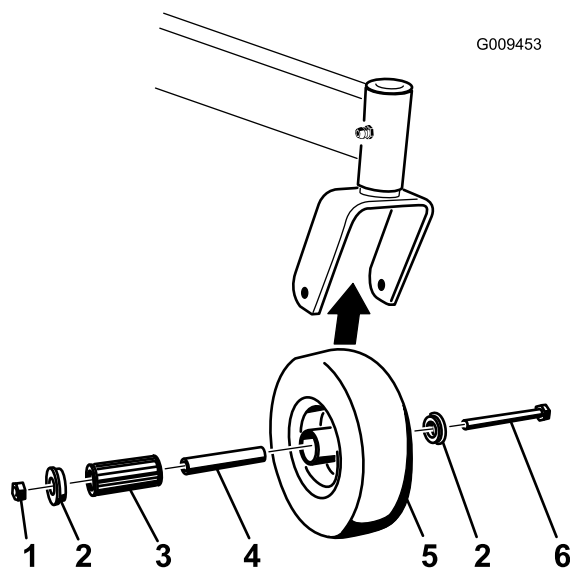

**Figure 60**

- |               |                    |
|---------------|--------------------|
| 1. Locknut    | 4. Spanner bushing |
| 2. Wheel bolt | 5. Roller bearing  |
| 3. Bushing    |                    |

## Servicing the Clutch

### Checking the Clutch

**Service Interval:** Every 200 hours—Check the clutch.

If the clutch takes too much time to start the mower deck or stop the mower deck, the clutch needs adjustment.

To check the clutch, perform steps C, E and F under the procedure of Removing the Clutch Shim.

### Removing the Clutch Shim

This unit has been built with a clutch that contains a brake shim. When the clutch brake has worn to the point where the clutch no longer engages consistently, the shim can be removed to extend the clutch life.

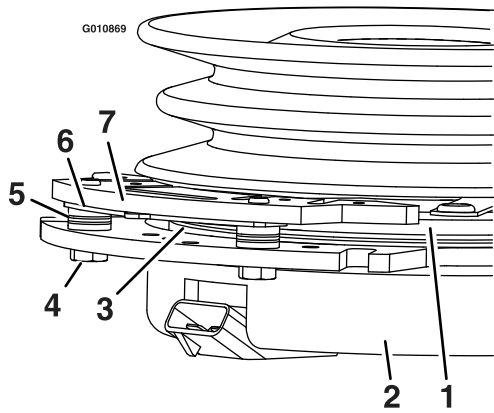

**Figure 61**

- |                        |                 |
|------------------------|-----------------|
| 1. Armature            | 5. Brake spacer |
| 2. Field shell         | 6. Re-gap shim  |
| 3. Rotor               | 7. Brake pole   |
| 4. Brake-mounting bolt |                 |

1. Stop the engine, wait for all moving parts to stop, remove the key, engage the parking brake, and allow the machine to cool completely before starting these instructions.
2. Using an air compressor, blow out any debris from under the brake pole and around the brake spacers.

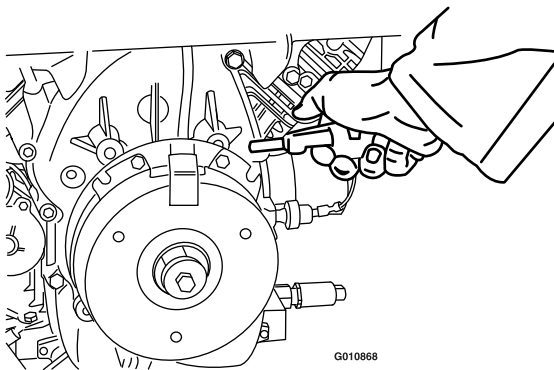
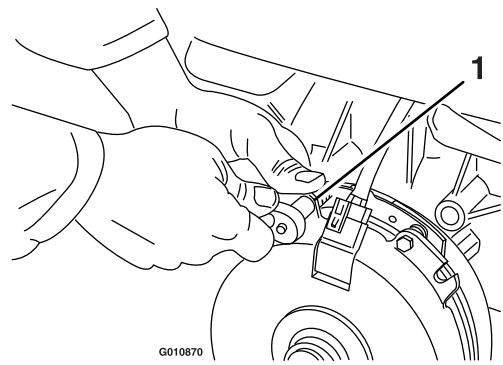

**Figure 62**

3. Check the condition of the wire harness leads, connectors, and terminals.
 

**Note:** Clean or repair as necessary.
4. Verify that 12V is present at the clutch connector when the PTO switch is engaged.
5. Measure the gap between the rotor and armature. If the gap is greater than 1 mm (0.04 inch), proceed with the following steps:
  - A. Loosen both brake mounting bolts 1/2 to 1 full turn as shown below.

**Note:** Do not remove the brake pole from the field shell/armature. The brake pole has worn to match the armature and needs to continue to match after the shim is removed to ensure proper brake torque.



**Figure 63**

1. Brake-mounting bolt

- B. Using needle nose pliers, or by hand, take hold of the tab and remove the shim (Do not discard the shim until the proper clutch function has been confirmed).

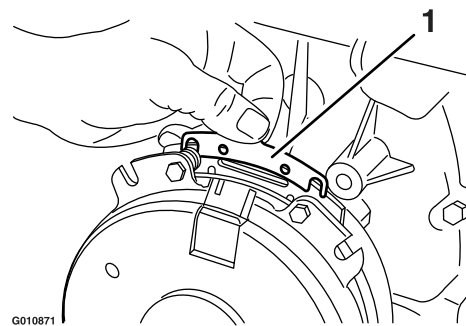
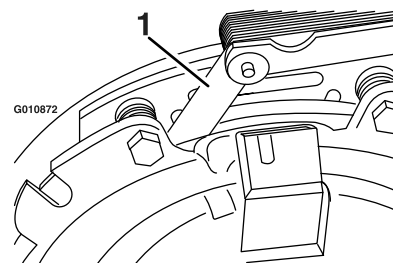

**Figure 64**

1. Shim

- C. Using a pneumatic line, blow out any debris from under the brake pole and around the brake spacers.
- D. Torque each bolt (M6 x 1) to 13 N-m (10 ft-lb) +/- 0.7 N-m (0.5 ft-lb).
- E. Using a 0.01 inch thick feeler gauge, verify that a gap is present between the rotor and armature face on both sides of the brake pole as shown.

**Note:** Due to the way the rotor and armature faces wear (peaks and valleys) it is sometimes difficult to measure the true gap.



**Figure 65**

1. Feeler gauge

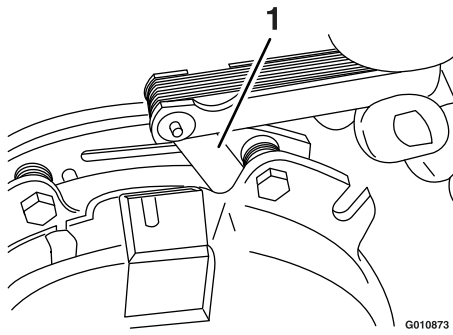

**Figure 66**

1. Feeler gauge

- If the gap is less than 0.25 mm (0.01 inch), then install the shim.
- If the gap is sufficient, proceed to the safety check in step F.

F. Perform the following safety check:

- i. Sit on the seat, and start the engine.
- ii. Make sure the blades do not engage with the PTO switch in the off position and the clutch disengaged.

If the clutch does not disengage, install the shim.

- iii. Engage and disengage the PTO switch 10 consecutive times to ensure that the clutch is functioning properly.

# Cooling System Maintenance

## Cleaning the Air-intake Screen

**Service Interval:** Before each use or daily

Before each use, remove any buildup of grass, dirt, or other debris from the cylinder and cylinder head cooling fins, air intake screen on the flywheel end, and the carburetor-governor levers and linkage. This will help ensure adequate cooling and correct engine speed, and will reduce the possibility of overheating or mechanical damage to the engine.

## Cleaning the Cooling System

**Service Interval:** Every 100 hours—Check and clean the engine cooling fins and shrouds.

1. Disengage the PTO and set the parking brake.
2. Stop the engine, remove the key, and wait for all moving parts to stop before leaving the operating position.
3. Remove the air-intake screen and fan housing (Figure 67).
4. Clean the debris and grass from the engine parts.
5. Install the air-intake screen, the recoil starter, and the fan housing (Figure 67).

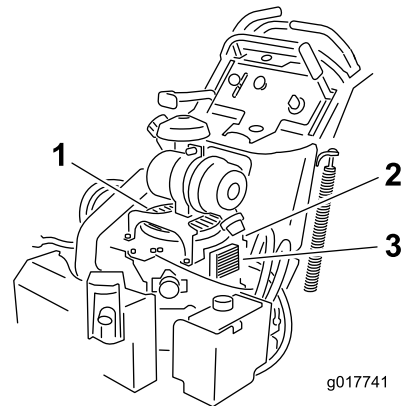

**Figure 67**

- |                                       |                      |
|---------------------------------------|----------------------|
| 1. Guard and engine air-intake screen | 3. Engine-oil cooler |
| 2. Fan housing                        |                      |

# Servicing the Engine-oil Cooler

**Service Interval:** Every 200 hours

1. Keep the oil cooler free of debris by cleaning the fins with a brush.
2. Remove the bolts holding the oil cooler to the engine housing ().
3. Clean the inside of the oil cooler with a brush.
4. Install the oil cooler to the engine housing.

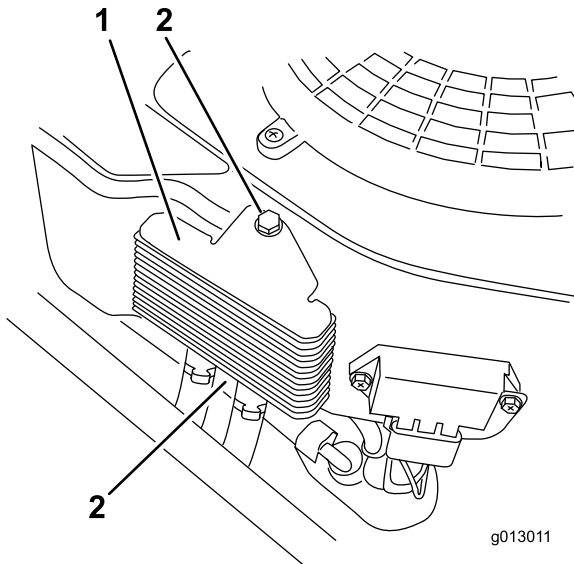

**Figure 68**

1. Engine-oil cooler
2. Bolts

---

# Cleaning the Hydraulic-oil Cooler

**Service Interval:** Before each use or daily

Before each use, remove any buildup of grass, dirt, or other debris from the hydraulic-oil cooler and fan. This will help ensure adequate cooling, correct engine speed, and reduce the possibility of overheating or mechanical damage to the engine.

**Note:** High pressure and over-speeding the fan may cause fan failure. Use care with compressed air to avoid over-speeding the electric fan.

**Important:** Do not direct a pressure washer on the electric fan.

# Servicing the Hydraulic-oil Cooler

**Service Interval:** Every 100 hours—Service the hydraulic-oil cooler in dirty conditions (if equipped).

1. Keep the hydraulic-oil cooler free of debris by cleaning the fins.
2. Blow the hydraulic-oil cooler fins to remove any loose dry debris.
3. Flush the cooler fins with water from a hose to remove any dirt.

**Note:** A soft brush (i.e. toothbrush) with a soap and water solution may be used to clean the cooler.

**Note:** Do not use a pressure washer.

**Note:** High pressure and over-speeding the fan may cause fan failure. Use care with compressed air to avoid over-speeding the electric fan.

**Important:** Do not direct a pressure washer on the electric fan.

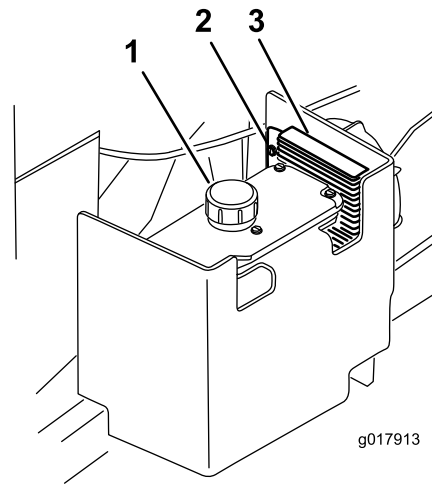

**Figure 69**

1. Hydraulic tank
2. Bolts
3. Hydraulic-oil cooler

# Brake Maintenance

## Servicing the Brake

Before each use, check the brakes on a level surface and slope.

Always set the parking brake when you stop the machine or leave it unattended.

**Important:** If the parking brake does not hold securely, an adjustment is required.

## Checking the Parking Brake

**Service Interval:** Before each use or daily

1. Park the machine on a level surface, disengage the PTO.
2. Stop the engine, remove the key, and wait for all moving parts to stop before leaving the operating position.
3. Release the brake.

**Note:** The brake bars should lift off the tires and the hand lever should travel forward to the end of the slot in the control panel.

**Note:** Adjust the brake if needed.

4. Engage the brake lever until the brake bars first contact the tire (Figure 70).
5. Measure the gap from the front of the hand lever to the end of the slot in the control panel when the brake bar contacts the tire (Figure 70).

**Note:** This measurement needs to be 19 mm (3/4 inch).

**Note:** Adjust the brake if needed.

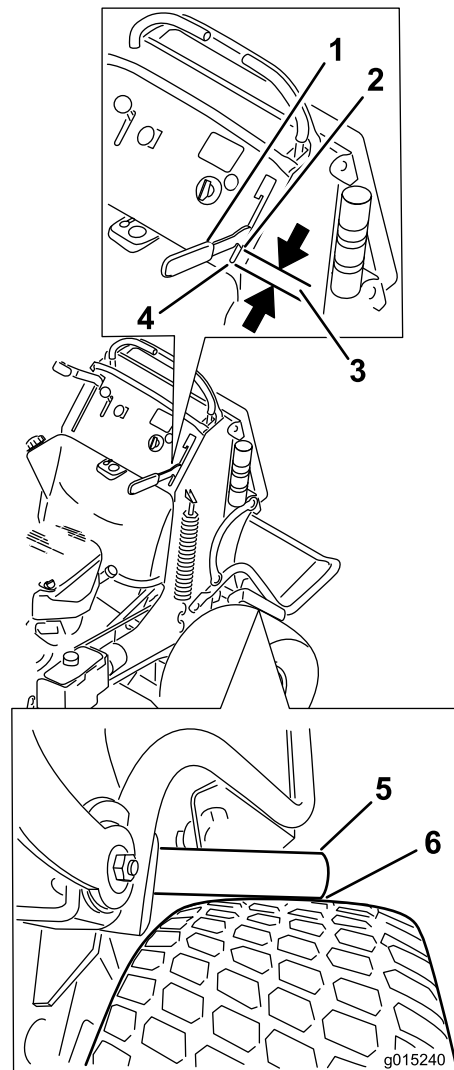

**Figure 70**

- |                         |                                     |
|-------------------------|-------------------------------------|
| 1. Hand lever           | 4. Front of slot                    |
| 2. Front of hand lever  | 5. Brake bar                        |
| 3. 19 mm (3/4 inch) gap | 6. Brake bar just touching the tire |

# Adjusting the Brakes

If the parking brake does not hold securely, an adjustment is required.

1. Check the brake before you adjust it; refer to Checking the Parking Brake (page 47).
2. Park the machine on a level surface, disengage the PTO, and set the parking brake.
3. Stop the engine, remove the key, and wait for all moving parts to stop before leaving the operating position.
4. Release the parking brake.
5. To adjust the brake, remove the hairpin cotter and clevis pin from the lower brake lever and yoke (Figure 71).
6. Loosen the jam nut (Figure 71).
7. Rotate the yoke (Figure 71).
- Note:** To tighten the brake, rotate the yoke up.
- Note:** To loosen the brake, rotate the yoke down.
8. Secure the yoke to the lower brake lever with the hairpin cotter and clevis pin (Figure 71).
9. Tighten the jam nut (Figure 71).
10. Check the brake operation again; refer to Checking the Parking Brake (page 47).

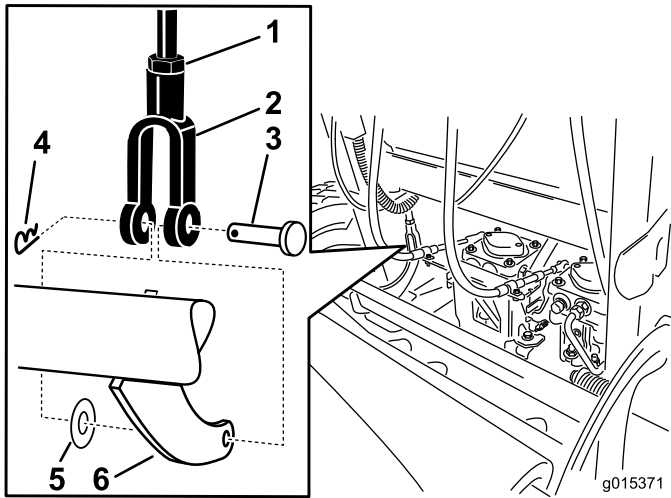

**Figure 71**

- |               |                      |
|---------------|----------------------|
| 1. Jam nut    | 4. Hairpin cotter    |
| 2. Yoke       | 5. Flat washer       |
| 3. Clevis pin | 6. Lower-brake lever |

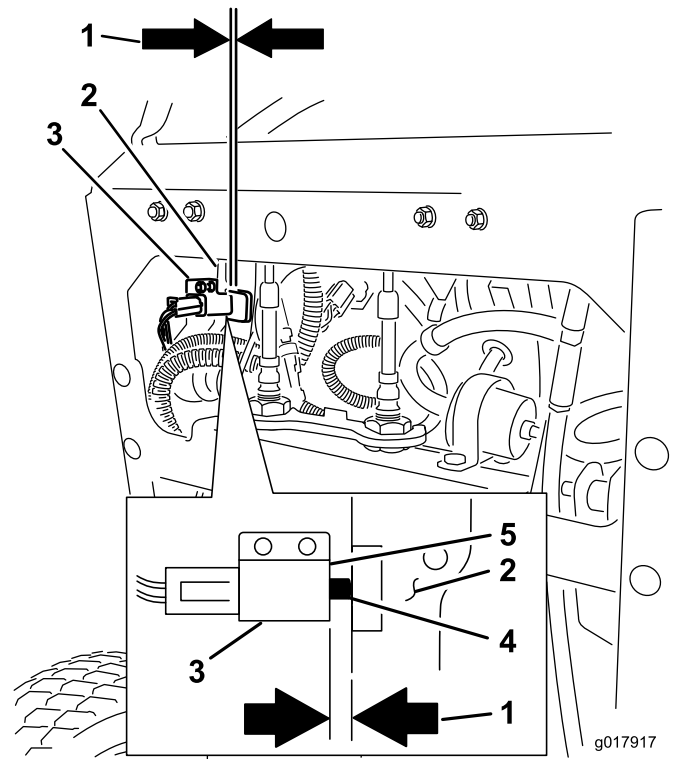

**Figure 72**

- |   |                       |
|---|-----------------------|
| 1. 3mm (1/8 inch) gap needed between the switch and the brake lever | 4. Switch button      |
| 2. Brake lever  | 5. Face of the switch |
| 3. Switch   |                       |

11. After the brake is adjusted, check the lever switch (Figure 72).
12. Check the gap between the brake lever and the face of the switch as shown in Figure 72.

**Note:** The gap needs to be within 3mm (1/8 inch) with the brake **engaged**.

13. If needed, loosen the screws holding the switch and adjust the switch.

# Belt Maintenance

## Replacing the Mower-deck Belt

**Service Interval:** Every 100 hours—Check the mower-deck belt.

Squeaking when the belt is rotating, the blade is slipping when cutting grass, frayed belt edges, burn marks, and cracks are signs of a worn deck belt.

Replace the deck belt if any of these conditions are evident.

1. Disengage the PTO and set the parking brake.
2. Stop the engine, remove the key, and wait for all moving parts to stop before leaving the operating position.
3. Unlatch and remove the belt covers.
4. Loosen the front idler pulley by loosening the nut (Figure 73 and Figure 74).
5. Remove the worn mower belt (Figure 73 and Figure 74).
6. Install the new mower belt around the deck pulleys and clutch pulley (Figure 73 and Figure 74).
7. Using a ratchet in the idler arm, tighten the idler pulley until the spring is stretched 16.5 cm (6.5 inches) from hook to hook (Figure 73 and Figure 74).
8. Tighten the front idler pulley by tightening the nut (Figure 73 and Figure 74).
9. Install the belt covers onto the cutting unit and secure the latches.

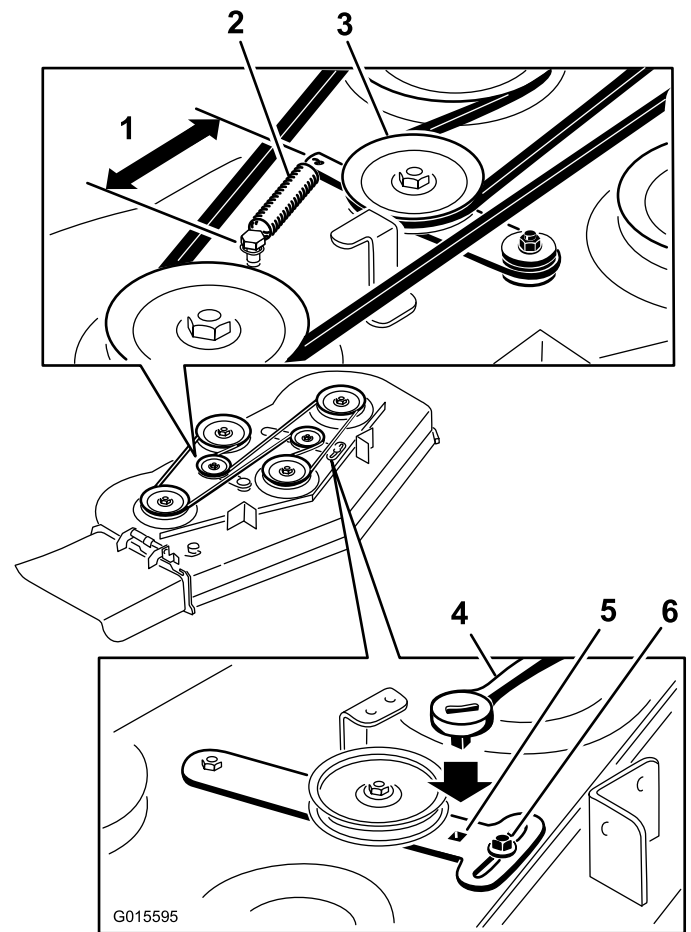

**Figure 73**

- |   |                            |
|---|----------------------------|
| 1. 16.5 cm (6.5 inches) from hook to hook | 4. Ratchet                 |
| 2. Spring                                 | 5. Square hole for ratchet |
| 3. Spring-loaded idler                    | 6. Nut                     |

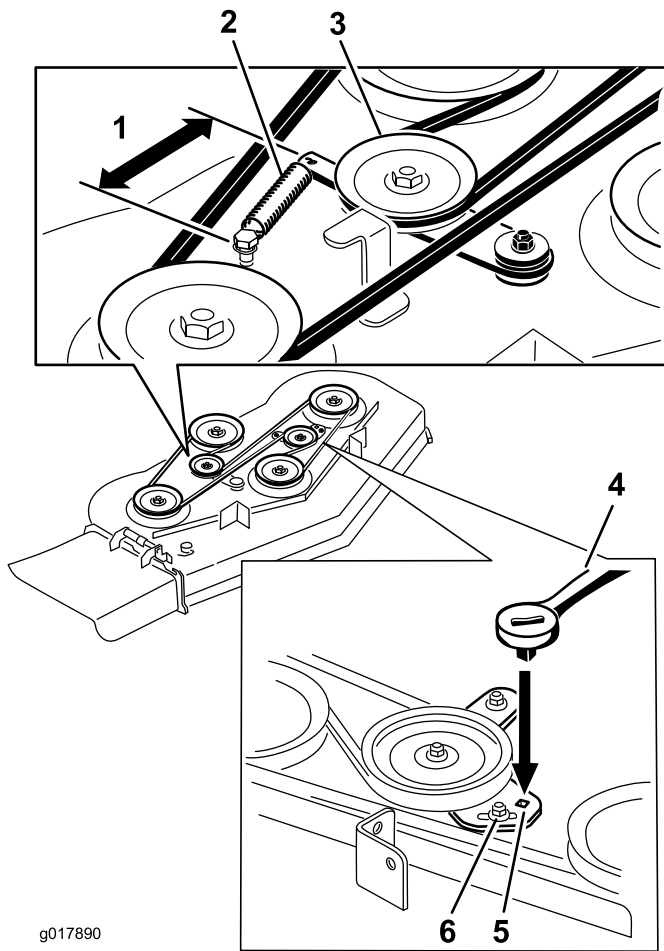

g017890

**Figure 74**

- |   |                            |
|---|----------------------------|
| 1. 16.5 cm (6.5 inches) from hook to hook | 4. Ratchet                 |
| 2. Spring                                 | 5. Square hole for ratchet |
| 3. Spring-loaded idler                    | 6. Nut                     |

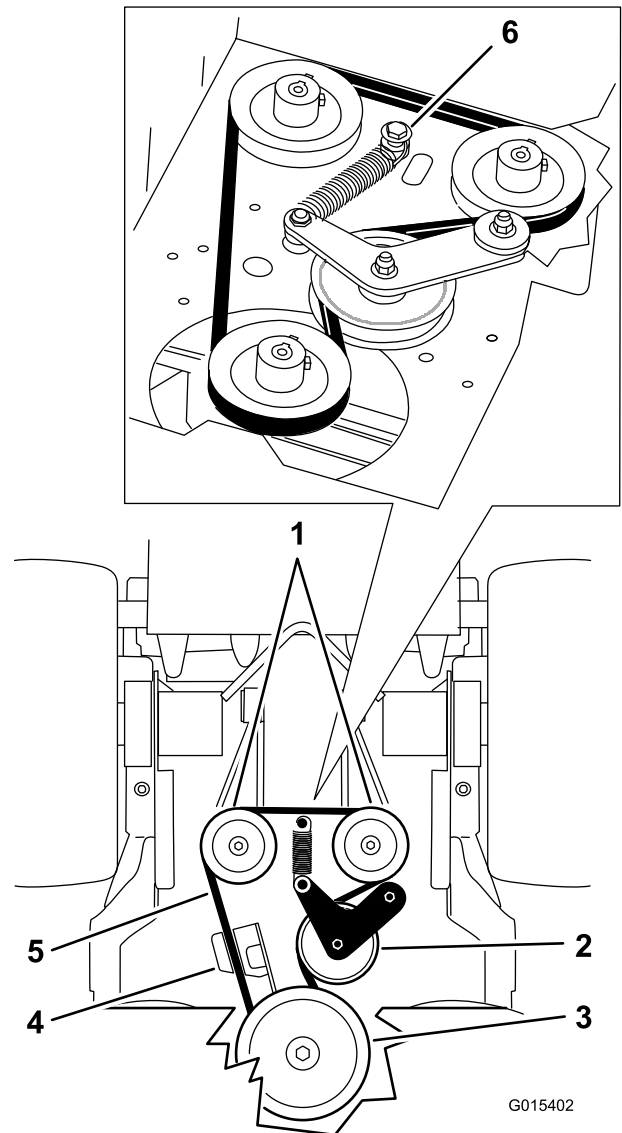

G015402

**Figure 75**

- |                    |                                   |
|--------------------|-----------------------------------|
| 1. Hydraulic pumps | 4. Clutch retainer                |
| 2. Idler pulley    | 5. Pump-drive belt                |
| 3. Clutch pulley   | 6. Shoulder bolt, nut, and washer |

## Replacing the Pump-drive Belt

**Service Interval:** Every 100 hours—Check the pump-drive belt.

1. Disengage the PTO and set the parking brake.
2. Stop the engine, remove the key, and wait for all moving parts to stop before leaving the operating position.
3. Remove the mower-deck belt.
4. Tilt the machine; refer to Raising the Mower for Access (page 28).
5. Remove the shoulder bolt, the nut, and the washer from the engine deck and connected spring (Figure 75).
6. Remove the pump-drive belt (Figure 75).
7. Install the new belt around the clutch and the 2 pump pulleys.
8. Install the spring onto the shoulder bolt and washer, and connect it to the engine deck with the nut (Figure 75).
9. Lower the machine to the operating position.
10. Install the mower-deck belt.

# Controls System Maintenance

## Adjusting the Motion-control-handle Positions

### Adjusting the Right Side Motion-control Lever

If the motion-control levers do not align horizontally, adjust the right side motion-control lever.

**Note:** Adjust the horizontal alignment before the front to back alignment.

1. Disengage the PTO, move the right side motion-control lever to the neutral position, and set the parking brake.
2. Stop the engine, remove the key, and wait for all moving parts to stop before leaving the operating position.
3. Push the right motion-control lever down out of the neutral-locked position (Figure 76).
4. Check if the right motion-control lever aligns horizontally with the left motion-control lever (Figure 76).

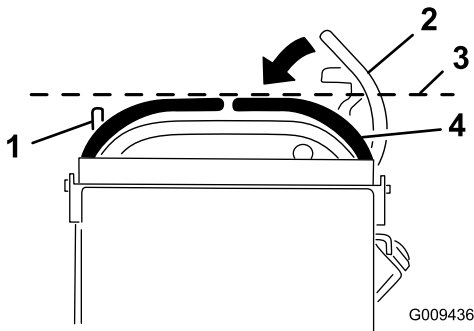

**Figure 76**

- |  |  |
|--|--|
| 1. Left motion-control lever                                 | 3. Check the horizontal alignment here |
| 2. Right motion-control lever in the neutral-locked position | 4. Right motion-control lever          |

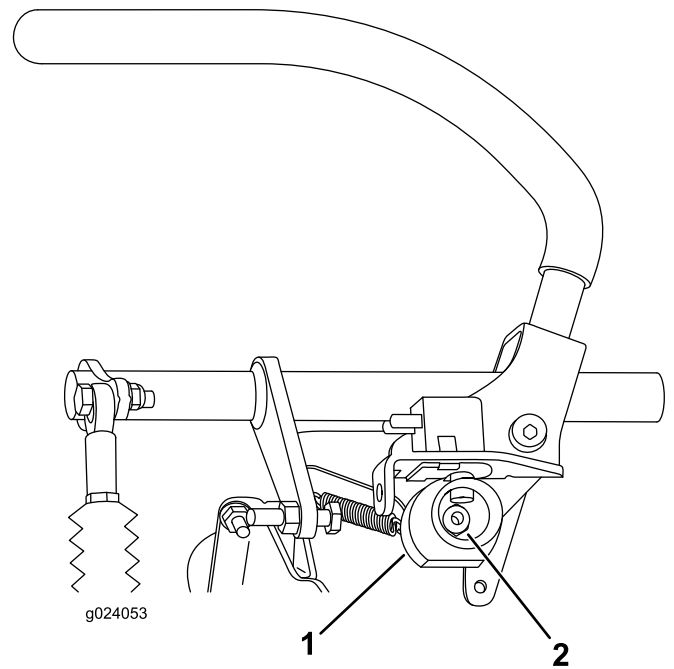

**Figure 77**

1. Cam

2. Nut

8. Adjust the cam until it aligns with the left motion-control lever and tighten the nut for the cam.

**Note:** Moving the cam clockwise (in the vertical position) lowers the handle, while moving it counterclockwise (in the vertical position) raises the handle.

**Important:** Ensure that the flat portion of the cam does not go above a vertical position (right or left), or you may cause damage to the switch.

5. To adjust the right motion-control lever horizontally, the cam needs to be adjusted.
6. Release the cushion from the rear of the machine.
7. Loosen the nut holding the cam (Figure 77).

## Adjusting the Neutral Position for the Motion-control Levers

**Important:** Ensure the tracking of the mower is correct after adjusting the motion-control levers. Adjusting the tracking and aligning the motion-control levers front to back is the same procedure (Figure 78).

**Note:** Adjust the horizontal alignment before the front to back alignment.

If the motion-control levers do not align front to back, or the right side control lever does not move easily into the neutral-lock position, adjustment is required.

1. After the horizontal alignment is finished, check the front to back alignment by slightly pushing the control levers forward to take up any slack in the linkage for the control levers (Figure 78).

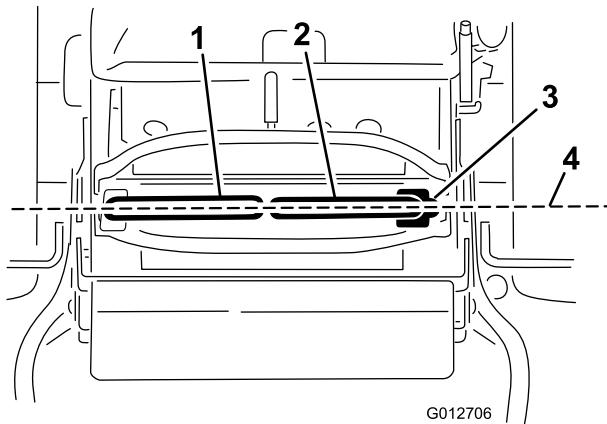

**Figure 78**

- |                               |   |
|-------------------------------|---|
| 1. Left motion-control lever  | 3. Neutral-locked position                |
| 2. Right motion-control lever | 4. Align the control levers front to back |

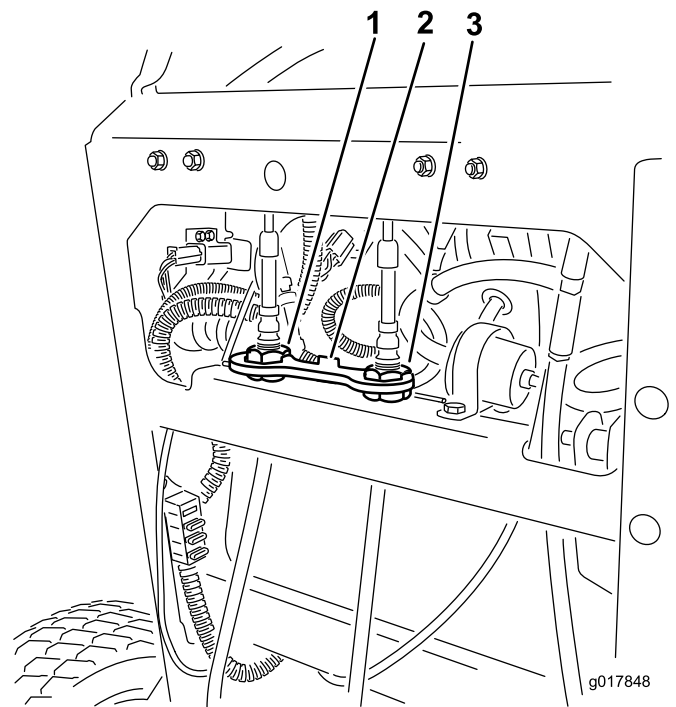

**Figure 79**

- |                          |                           |
|--------------------------|---------------------------|
| 1. Left cable adjustment | 3. Right cable adjustment |
| 2. Cable lock            |                           |

2. Ensure the right motion-control lever moves easily into the neutral-lock position.

**Note:** Turn the cable adjustment clockwise to move the motion-control handle forward. Turn the cable adjustment counterclockwise to move the motion-control handle rearward.

3. Rotate the cable adjustment on right side when adjustment is needed.

**Note:** Adjust the cable adjustment in quarter-turn increments.

4. After the right motion-control lever moves easily into the neutral-lock position, adjust the left motion-control lever to align with the right motion-control lever.
5. Check for proper tracking; refer to Adjusting the Tracking (page 41).
6. Install the cable lock onto the cable-adjusting nuts to secure the adjustment (Figure 79).

# Hydraulic System Maintenance

## Servicing the Hydraulic System

**Hydraulic Oil Type:** Toro® HYPR-OIL™ 500 hydraulic oil or Mobil® 1 15W-50 synthetic motor oil.

**Hydraulic System Oil Capacity:** 2 L (67 oz)

**Important:** Use oil specified. Other fluids could cause system damage.

## Checking the Hydraulic Fluid

**Service Interval:** After the first 8 hours

Every 50 hours

**Note:** There are 2 ways to check the hydraulic oil; when the oil is warm, or when the oil is cold. The baffle inside the tank has 2 levels depending if the oil is warm or cold.

1. Position the machine on a level surface.
2. Disengage the power take off (PTO) and shut off the engine.
3. Wait for all moving parts to stop before leaving the operating position and then set the parking brake.
4. Clean the area around the cap and the filler neck of the hydraulic tank (Figure 80).

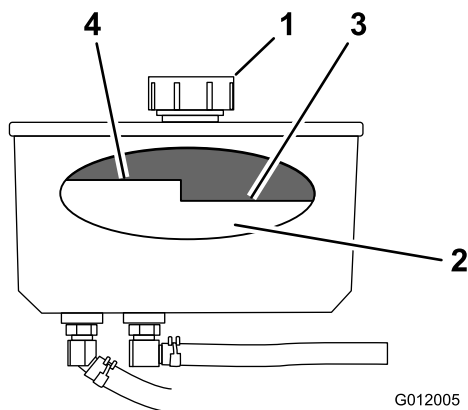

Figure 80

- |           |                          |
|-----------|--------------------------|
| 1. Cap    | 3. Cold fluid level—full |
| 2. Baffle | 4. Hot fluid level—full  |

5. Remove the cap from the filler neck (Figure 80).

**Note:** Look inside to check the fluid level in the reservoir.

6. Add fluid to the reservoir until it reaches the cold level of the baffle.
7. Run the machine at low idle for 15 minutes to allow any air to purge out of the system and warm the fluid; refer to Starting and Stopping the Engine (page 17).

8. Check the fluid level while the fluid is warm.

**Note:** If required, add fluid to the reservoir until it is between the hot level and the cold level.

**Note:** The fluid level should be below the hot level of the baffle when the fluid is warm (Figure 80).

9. Install the cap on the filler neck.

## ⚠ WARNING

**Hydraulic fluid escaping under pressure can penetrate skin and cause injury.**

- If hydraulic fluid is injected into the skin, it must be surgically removed within a few hours by a doctor familiar with this type of injury. Gangrene may result if this is not done.
- Keep your body and hands away from pinhole leaks or nozzles that eject high-pressure hydraulic fluid.
- Use cardboard or paper to find hydraulic leaks.
- Safely relieve all pressure in the hydraulic system before performing any work on the hydraulic system.
- Make sure all hydraulic-fluid hoses are in good condition, and all that the hydraulic connections and fittings are tight before applying pressure to hydraulic system.

## Replacing the Hydraulic Fluid

**Service Interval:** Every 250 hours—Change the hydraulic filter and hydraulic oil when using Mobil® 1 oil.

Every 500 hours/Yearly (whichever comes first)—Change the hydraulic filter and hydraulic oil when using Toro® HYPR-OIL™ 500 hydraulic oil.

**Note:** Change the hydraulic fluid more frequently in severe conditions or in a hot operating climate.

## ⚠ WARNING

**Hot hydraulic fluid can cause severe burns.**

**Allow the hydraulic fluid to cool before performing any maintenance to the hydraulic system.**

1. Disengage the PTO and set the parking brake.
2. Stop the engine and wait for all moving parts to stop before leaving the operating position.
3. Remove hydraulic-reservoir cap.
4. Locate the front hydraulic hose under the hydraulic tank, and place a drain pan under the tank (Figure 81).

5. Loosen the hose clamp and move it down the hose.
6. Remove the front hydraulic hose, and allow the fluid to run out of the tank.

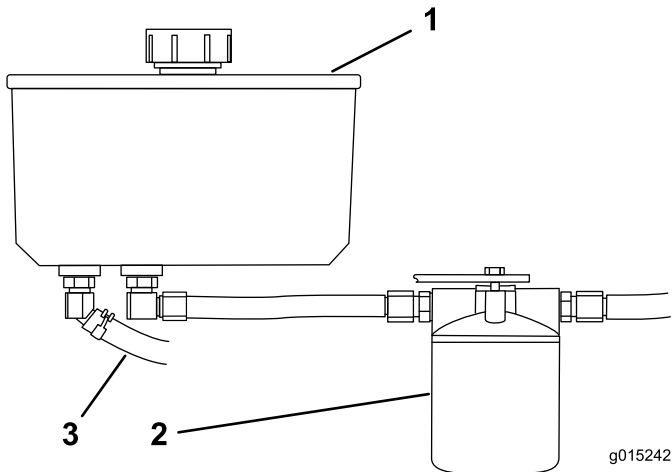

**Figure 81**

- |                     |                         |
|---------------------|-------------------------|
| 1. Hydraulic tank   | 3. Front hydraulic hose |
| 2. Hydraulic filter |                         |

7. Change the hydraulic filter; refer to Replacing the Hydraulic Filter (page 54).
8. Connect the hydraulic hose under the tank.
9. Add fluid to the tank until it reaches the cold baffle of the tank.

**Important:** Use oil specified or equivalent. Other fluids could cause system damage.

10. Install the hydraulic-tank cap.
11. Start the engine and let it run for about 2 minutes to purge air from the system.
12. Stop the engine and check for leaks.

**Note:** If one or both wheels will not drive, refer to Bleeding the Hydraulic System (page 55).

13. Check the level of the fluid and add fluid, if required.

**Note:** Do not overfill.

## Replacing the Hydraulic Filter

**Service Interval:** After the first 8 hours

### **▲ WARNING**

Hot hydraulic fluid can cause severe burns.

Allow the hydraulic fluid to cool before performing any maintenance to the hydraulic system.

**Important:** Do not substitute with an automotive oil filter, or severe hydraulic system damage may result.

1. Disengage the PTO and set the parking brake.
2. Stop the engine and wait for all moving parts to stop before leaving the operating position.
3. Locate the filter and place a drain pan under filter (Figure 82).

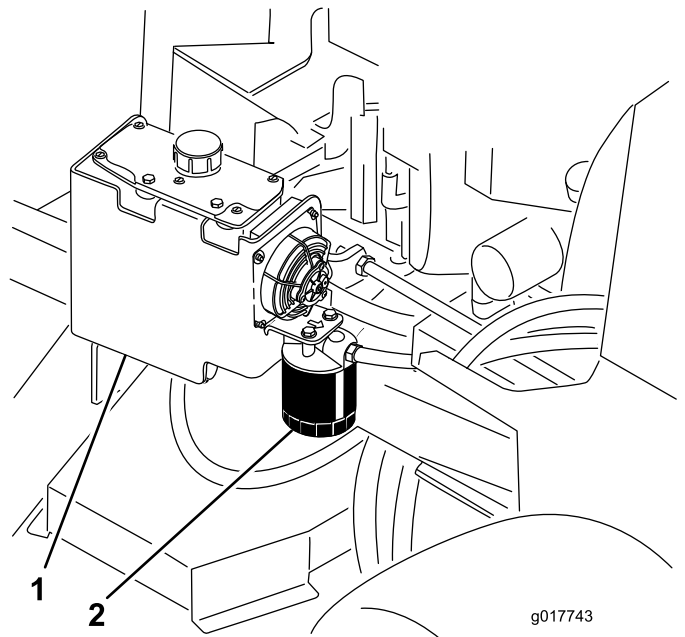

**Figure 82**

- |                   |                     |
|-------------------|---------------------|
| 1. Hydraulic tank | 2. Hydraulic filter |
|-------------------|---------------------|

4. Remove the old filter and wipe the filter-adapter gasket surface clean (Figure 83).
5. Apply a thin coat of hydraulic fluid to the rubber gasket on the replacement filter.
6. Install the replacement hydraulic filter onto the filter adapter.
7. Turn the oil filter clockwise until the rubber gasket contacts the filter adapter, then tighten the filter an additional 1/2 turn (Figure 83).

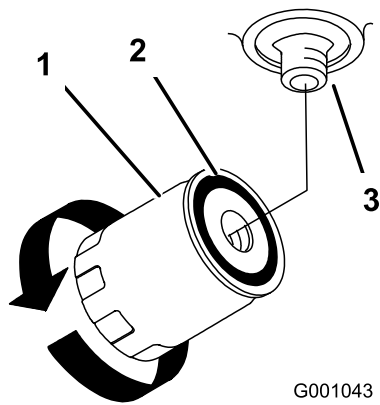

**Figure 83**

- |                     |            |
|---------------------|------------|
| 1. Hydraulic filter | 3. Adapter |
| 2. Gasket           |            |

## Checking the Hydraulic Lines

**Service Interval:** Every 100 hours

Check hydraulic hoses and hoses for leaks, loose fittings, kinked hoses, loose mounting supports, wear, general weathering, and chemical deterioration. Make any necessary repairs before operating.

**Note:** Keep areas around the hydraulic system clean from grass and debris buildup.

**Note:** Extended operating time at high temperatures in a hot climate may lead to deterioration of hoses and seals. Inspect more frequently in a hot climate, and change the hydraulic oil and filter more frequently.

8. Clean up any spilled fluid.
9. Check the fluid in the reservoir, and add fluid to the tank until it reaches the cold baffle of the tank.

**Important:** Use the oil specified or equivalent. Other fluids could cause system damage.

10. Start the engine and let it run for about 2 minutes to purge air from the system.
11. Stop the engine and check for leaks.

**Note:** If one or both wheels will not drive, refer to Bleeding the Hydraulic System (page 55).

12. Check the level of the fluid and add fluid, if required.

**Note:** Do not overfill.

## Bleeding the Hydraulic System

The traction system is self-bleeding, however, it may be necessary to bleed the system if fluid is changed or after work is performed on the system.

1. Disengage the PTO and set the parking brake.
2. Stop the engine and wait for all moving parts to stop before leaving the operating position.
3. Raise the rear of the machine onto jack stands high enough to raise the drive wheels off the ground.
4. Start the engine and move the throttle control to the idle position.

**Note:** If the drive wheel does not rotate, it is possible to assist the purging of the system by carefully rotating the tire in the forward direction.

5. Check the hydraulic fluid level as it drops, and add fluid as required to maintain the proper level.
6. Repeat this procedure for the opposite wheel.
7. Thoroughly clean the area around each of the charge pump housings.

# Mower Deck Maintenance

## Servicing the Cutting Blades

To ensure a superior quality of cut, keep the blades sharp. For convenient sharpening and replacement, you may want to keep extra blades on hand.

### ⚠ WARNING

A worn or damaged blade can break, and a piece of the blade could be thrown into the operator's or bystanders' area, resulting in serious personal injury or death.

- Inspect the blades periodically for wear or damage.
- Replace a worn or damaged blade.

## Before Inspecting or Servicing the Blades

Park the machine on a level surface, disengage the blades and set the parking brake. Turn the ignition key to off. Remove the key, and disconnect the spark plug wires from the spark plugs.

## Inspecting the Blades

**Service Interval:** Before each use or daily

1. Inspect the cutting edges (Figure 84).
2. If the edges are not sharp or have nicks, remove and sharpen the blade; refer to Sharpening the Blades (page 57).
3. Inspect the blades, especially in the curved area.
4. If you notice any cracks, wear, or a slot forming in this area, immediately install a new blade (Figure 84).

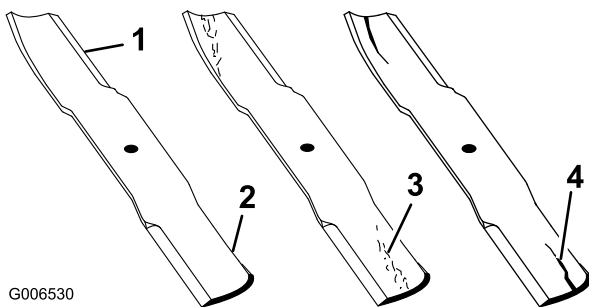
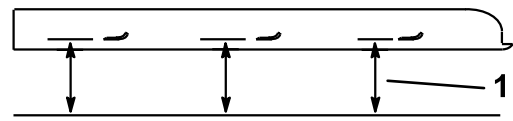
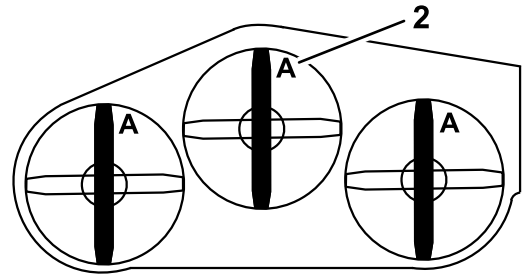

Figure 84

1. Cutting edge
2. Curved area
3. Wear/slot forming
4. Crack

## Checking for Bent Blades

1. Disengage the PTO, move the motion-control levers to the neutral-locked position, and set the parking brake.
2. Stop the engine, remove the key, and wait for all moving parts to stop before leaving the operating position.
3. Rotate the blades until the ends face forward and backward.
4. Measure from a level surface to the cutting edge, position **A**, of the blades (Figure 85).



G000975

Figure 85

1. Measure here from blade
2. Position A to hard surface

5. Rotate the opposite ends of the blades forward.
6. Measure from a level surface to the cutting edge of the blades at the same position as in step 4 above.

**Note:** The difference between the dimensions obtained in steps 4 and 5 must not exceed 3 mm (1/8 inch).

**Note:** If this dimension exceeds 3 mm (1/8 inch), the blade is bent and must be replaced.

### ⚠ WARNING

A blade that is bent or damaged could break apart and could seriously injure or kill you or bystanders.

- Always replace bent or damaged blade with a new blade.
- Do not file or create sharp notches in the edges or surfaces of the blade.

## Removing the Blades

Blades must be replaced if a solid object is hit, if the blade is out of balance, or if the blade is bent. To ensure optimum performance and continued safety conformance of the machine, use genuine Toro replacement blades. Replacement blades made by other manufacturers may result in nonconformance with safety standards.

1. Hold the blade end using a rag or a thickly-padded glove.
2. Remove the blade bolt, the curved washer, and the blade from the spindle shaft (Figure 86).

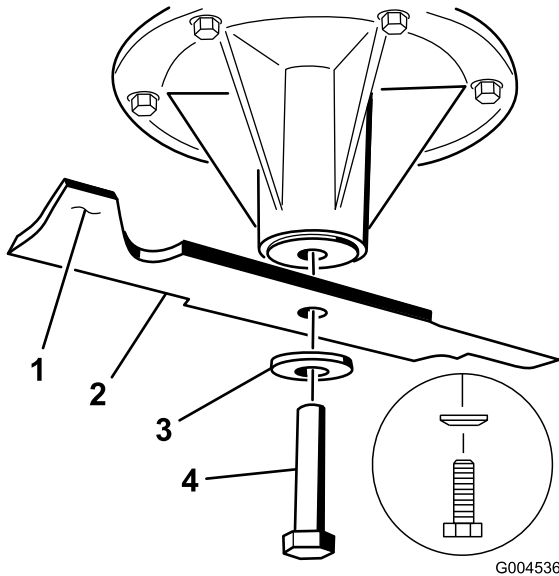

Figure 86

- |                           |                  |
|---------------------------|------------------|
| 1. Sail area of the blade | 3. Curved washer |
| 2. Blade                  | 4. Blade bolt    |

## Sharpening the Blades

1. Use a file to sharpen the cutting edge at both ends of the blade (Figure 87).

**Note:** Maintain the original angle.

**Note:** The blade retains balance if the same amount of material is removed from both cutting edges.

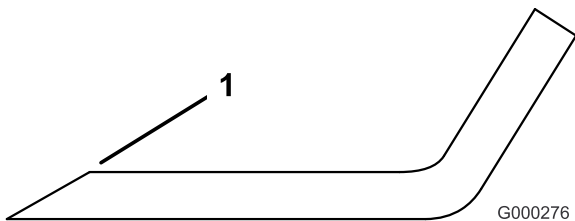

Figure 87

1. Sharpen at the original angle

2. Check the balance of the blade by putting it on a blade balancer (Figure 88).

**Note:** If the blade stays in a horizontal position, the blade is balanced and can be used.

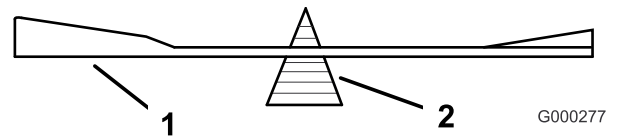

Figure 88

- |          |             |
|----------|-------------|
| 1. Blade | 2. Balancer |
|----------|-------------|

3. If the blade is not balanced, file some metal off the end of the sail area only (Figure 86).
4. Repeat this procedure until the blade is balanced.

## Installing the Blades

1. Install the blade onto the spindle shaft (Figure 89).

**Important:** The curved part of the blade must be pointing upward toward the inside of the mower to ensure proper cutting.

2. Install the spring disk and blade bolt (Figure 89).

**Note:** The spring-disk cone must be installed toward the bolt head (Figure 89).

3. Torque the blade bolt to 115 to 150 N-m (85 to 110 ft-lb).

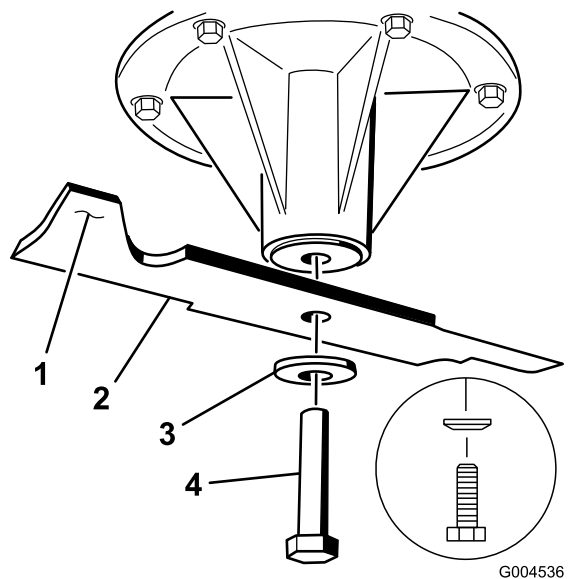

Figure 89

- |                           |                |
|---------------------------|----------------|
| 1. Sail area of the blade | 3. Spring disk |
| 2. Blade                  | 4. Blade bolt  |

## Correcting the Mower Quality-of-Cut

If one deck blade cuts lower than the other, correct it as follows:

**Note:** Tire air pressure is critical in these procedures; make sure the rear tires have the correct pressure.

1. Disengage the PTO and set the parking brake.
2. Stop the engine, remove the key, and wait for all moving parts to stop before leaving the operating position.
3. Disconnect the spark plug wire(s) from the spark plug(s).
4. Adjust the tire pressure in the rear tires to 83 to 97 kPa (12 to 14 psi).
5. Check that the blades and spindle shafts are not bent; refer to Checking for Bent Blades (page 56).
6. Set the height-of-cut to the 7.6 cm (3 inches) position; refer to Adjusting the Height-of-Cut (page 24).

## Checking the Mower Deck Side-to-Side Height

1. Adjust the rear-tire pressure.
2. Ensure that the blades are not bent; refer to Checking for Bent Blades (page 56).
3. Position the blades side-to-side.
4. Measure at the **B** and **C** locations from a level surface to the cutting edge of blade tips (Figure 90).

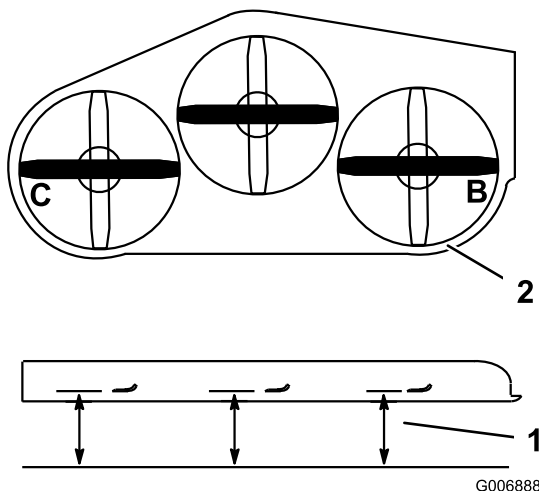

**Figure 90**

1. Measure from a level surface
2. Measure the blade at points **B** and **C**

5. The difference between measurements **B** and **C** should be no more than 6 mm (1/4 inch).

**Note:** If it is not correct, refer to Changing the Mower Deck Side-to-Side Height (page 58).

## Changing the Mower Deck Side-to-Side Height

Changing the side-to-side height is done by adjusting the rear-tire pressure and U-plates on the side of the engine deck.

1. Change the rear-tire pressure.

**Note:** Do this to the corresponding side that needs adjustment.

2. Locate the U-plates on the side of the engine deck (Figure 91).
3. Loosen the U-plate on 1 side, and adjust it up or down to make the difference between measurements **B** and **C** no more than a 6 mm (1/4 inch) as shown in Figure 91.
4. Proceed to Checking the Mower Deck Front-to-Rear Pitch (page 58).

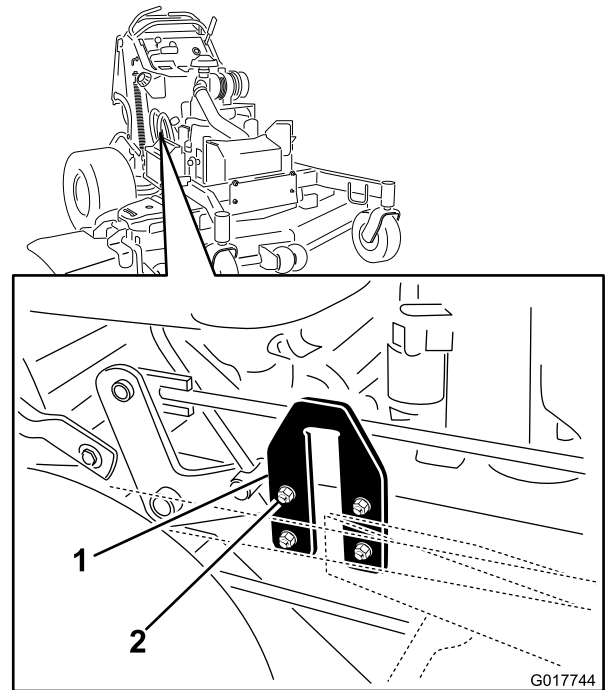

**Figure 91**

1. U-plate
2. Nuts and bolts

## Checking the Mower Deck Front-to-Rear Pitch

1. Adjust the tire pressure in the rear tires to the correct specifications.
2. Position 1 blade front-to-rear. Measure at **A** and **B** locations from a level surface to the cutting edge of the blade tips (Figure 92).

**Note:** The mower blade should be 6 mm (1/4 inch) lower in front at **A** than in the rear at **B**.

3. Rotate the blades and repeat for other blades.

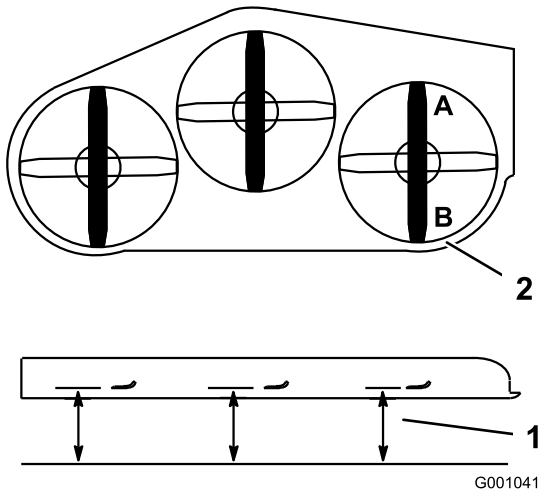

**Figure 92**

1. Measure the blade at points **A** and **B**
2. Measure from a level surface

4. If it is not correct, refer to Changing the Mower Deck Front-to-Rear Pitch (page 59).

## Changing the Mower Deck Front-to-Rear Pitch

Changing the front-to-rear pitch is done by adjusting the front height-of-cut posts.

1. Place 3 pieces of 2x4 wood under the mower deck as shown in Figure 93.
2. Stand the 2x4 pieces on the 4-inch part.

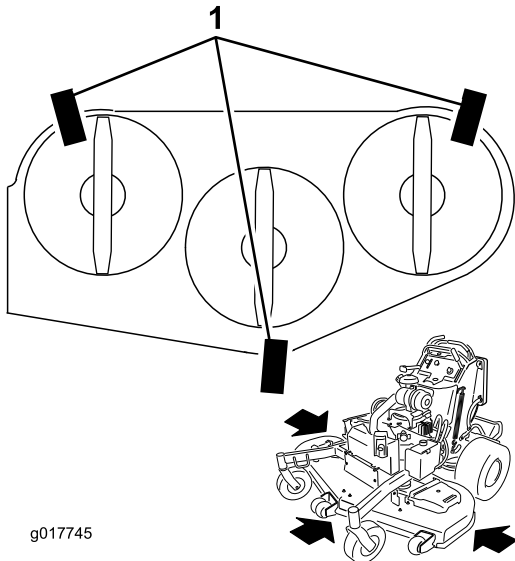

**Figure 93**

1. 2x4 piece of wood under the mower deck

3. For 48 and 52-inch mower decks, loosen both the front and rear nuts on the adjustment rods (Figure 94).

4. For 60-inch mower decks, loosen both the front and rear nuts and lift links on the adjustment rods (Figure 95).

**Note:** The weight of the mower deck must be resting on all 3 of the 2x4 pieces (Figure 94).

**Note:** The back lip of the mower deck is built 6mm (1/4 inch) lower than the front lip of the mower deck.

5. For 60-inch mower decks, tighten the lift links (Figure 95).
6. Tighten both the front and rear nuts.
7. Check the front-to-rear pitch of the cutting unit.
8. If the dimensions are not correct, adjust the front and rear nuts on either side to get the correct front-to-rear pitch (Figure 94).

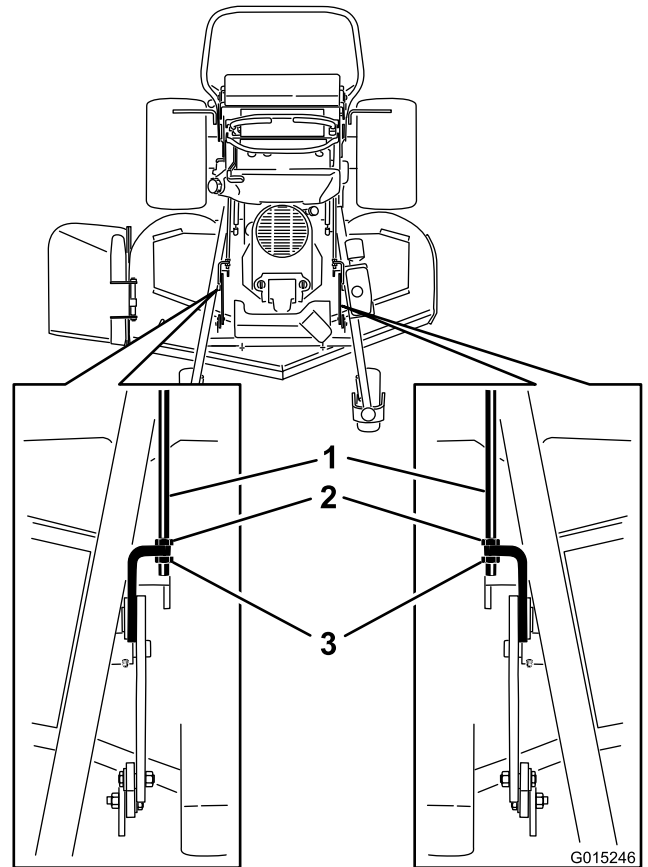

**Figure 94**

48 and 52-inch mower decks

1. Adjustment rods
2. Rear nuts
3. Front nuts

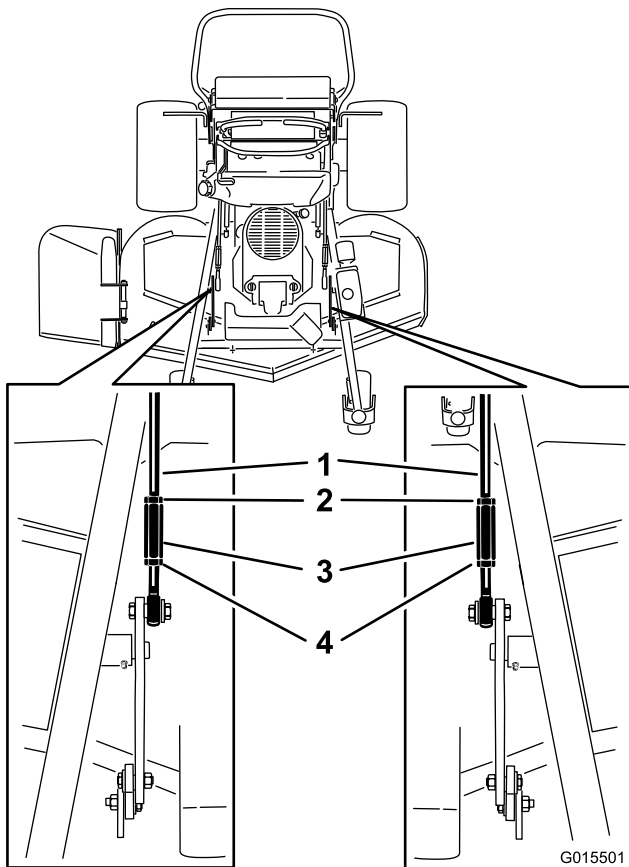

**Figure 95**  
60-inch mower decks

- |                    |               |
|--------------------|---------------|
| 1. Adjustment rods | 3. Lift link  |
| 2. Rear nuts       | 4. Front nuts |

## Matching the Height-of-Cut

1. Check the rear tire pressure.
2. Set the height-of-cut to the 7.6 cm (3 inches) position; refer to Adjusting the Height-of-Cut (page 24).
3. With the machine on level surface, position one blade front-to-rear.
4. Measure at **A**, and from a level surface to the cutting edge of the blade tips (Figure 96).

**Note:** The measurement should be 7.6 cm (3 inches).

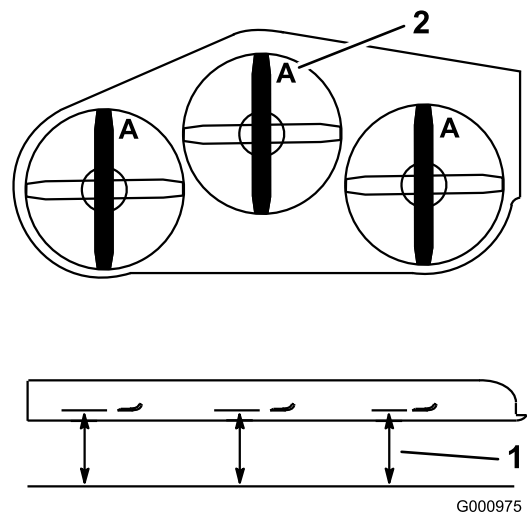

**Figure 96**

- |                                 |  |
|---------------------------------|--|
| 1. Measure from a level surface | 2. Measure the blade at point <b>A</b> |
|---------------------------------|--|

5. If it does not measure correctly, locate the height-of-cut rod on the right side of the machine (Figure 97).
6. Adjust the adjustment bolt until the blade tips match 7.6 cm (3 inches) as shown in Figure 97.

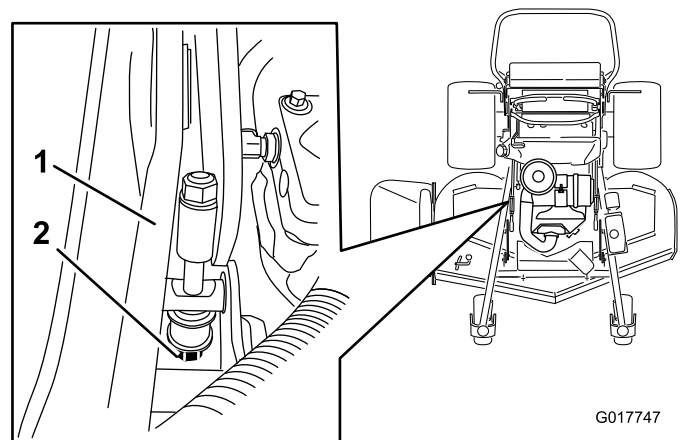

**Figure 97**

- |                      |                    |
|----------------------|--------------------|
| 1. Height-of-cut rod | 2. Adjustment bolt |
|----------------------|--------------------|

## Adjusting the Deck-lift Spring

**Note:** Adjusting the deck-lift spring will alter how much the deck will float and how much effort it takes to lift the deck when using the height-of-cut handle.

1. Raise the deck-lift lever and lock it into the transport position.
2. Check the length between the spring nut and the bottom of the welded U-bracket (Figure 98).
3. Ensure that the length is between 47 to 50 mm (1.8 to 2 inches) for 48 and 52-inch mower decks, and between 43 to 46 mm (1.7 to 1.8 inches) for 60-inch mower decks (Figure 98).
4. If needed, adjust the distance by adjusting the bolt on top of the U-bracket (Figure 98).

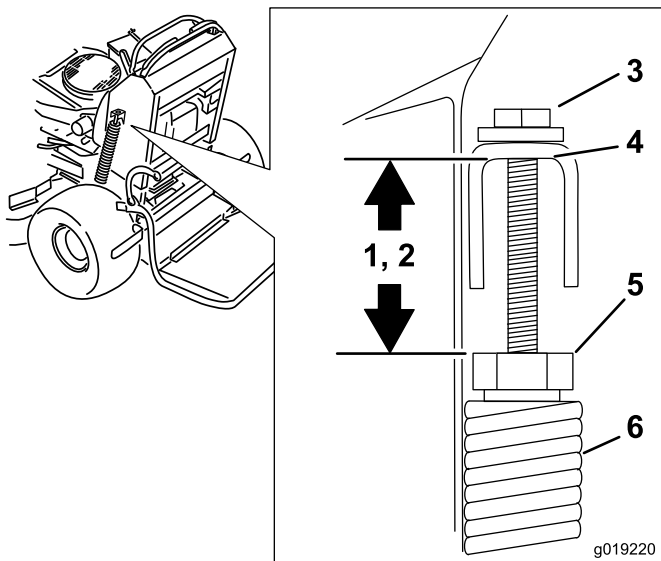

**Figure 98**

- |   |                                   |
|---|-----------------------------------|
| 1. Length is between 47 to 50 mm (1.8 to 2 inches) for 48 and 52-inch mower decks | 4. Bottom of the welded U-bracket |
| 2. Length is between 43 to 46 mm (1.7 to 1.8 inches) for 60-inch mower decks      | 5. Spring nut                     |
| 3. Adjustment bolt  | 6. Deck-lift spring               |

5. Repeat this procedure for the opposite deck-lift spring.

## Replacing the Grass Deflector

### ⚠ WARNING

An uncovered discharge opening could allow the lawn mower to throw objects in the operator's or bystander's direction and result in serious injury. Also, contact with the blade could occur.

**Do not operate the lawn mower unless you install a cover plate, a mulch plate, grass deflector, or bagger.**

1. Remove the locknut, bolt, spring, and spacer holding the deflector to the pivot brackets (Figure 99).

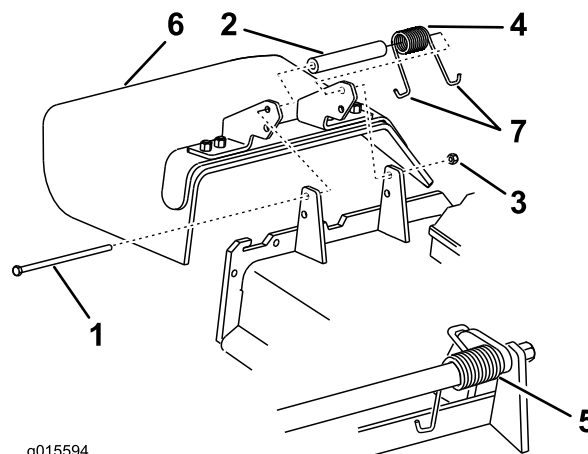

**Figure 99**

- |            |                             |
|------------|-----------------------------|
| 1. Bolt    | 5. Spring (installed)       |
| 2. Spacer  | 6. Grass deflector          |
| 3. Locknut | 7. J-hook end of the spring |
| 4. Spring  |                             |

2. Remove the damaged or worn grass deflector.
3. Place the spacer and the spring onto the grass deflector.
4. Place 1 J end of the spring behind the deck edge.

**Note:** Make sure 1 J end of spring is installed behind deck edge before installing the bolt as shown in Figure 99.

5. Install the bolt and the nut.
6. Place 1 J-hook end of the spring around the grass deflector (Figure 99).

**Important:** The grass deflector must be able to rotate. Lift the deflector up to the full open position, and ensure that it rotates into the full down position.

# Cleaning

## Cleaning Under the Mower

**Service Interval:** Before each use or daily

Remove the grass buildup under the mower daily.

1. Disengage the PTO, move the motion-control levers to the neutral-locked position and set the parking brake.
2. Stop the engine, remove the key, and wait for all moving parts to stop before leaving the operating position.
3. Raise the front of the machine and use jack stands to support the mower.

## Disposing of the Waste

Engine oil, batteries, hydraulic oil, and engine coolant are pollutants to the environment. Dispose of these according to your state and local regulations.

# Storage

## Cleaning and Storage

1. Disengage the power take off (PTO), set the parking brake, turn the ignition key to off, and remove the key.
2. Remove grass clippings, dirt, and grime from the external parts of the entire machine, especially the engine.

**Important:** You can wash the machine with a mild detergent and water. Do not pressure wash the machine. Avoid excessive use of water, especially near the drive system and engine. Pressure washing can force dirt and water into critical parts, such as spindle bearings and electrical switches.

3. Clean dirt and chaff from the outside of the engine cylinder head fins and blower housing.
  4. Check the brake; refer to Servicing the Brake in Brake Maintenance (page 47).
  5. Service the air cleaner; refer to Servicing the Air Cleaner in Engine Maintenance (page 32).
  6. Grease the machine; refer to Greasing and Lubrication in Lubrication (page 30).
  7. Change the engine oil; refer to Servicing the Engine in Engine Maintenance (page 32).
  8. Check the tire pressure; refer to Checking the Tire Pressure in Drive System Maintenance (page 41).
  9. For long-term storage:
    - A. Add stabilizer/conditioner additive to fuel in the tank.
    - B. Run engine to distribute conditioned fuel through the fuel system (5 minutes).
    - C. Stop engine, allow to cool and drain the fuel tank; refer to Servicing the Fuel Tank in Fuel System Maintenance (page 36), or operate engine until it stops.
    - D. Restart engine and run until it stops. Repeat, on Choke until engine will not restart.
    - E. Dispose of fuel properly. Recycle as per local codes.
- Note:** Do not store stabilizer/conditioned gasoline over 90 days.
10. Remove the spark plug(s) and check its condition; refer to Servicing the Spark Plug in Engine Maintenance (page 32). With the spark plug(s) removed from the engine, pour two tablespoons of engine oil into the spark plug hole. Now use the starter to crank the engine and distribute the oil inside the cylinder. Install the spark plug(s). Do not install the wire on the spark plug(s).
  11. Check and tighten all bolts, nuts, and screws. Repair or replace any part that is damaged or defective.

12. Paint all scratched or bare metal surfaces. Paint is available from your Authorized Service Dealer.
13. Store the machine in a clean, dry garage or storage area. Remove the key from the ignition switch and keep it in a memorable place. Cover the machine to protect it and keep it clean.

# Troubleshooting

Problem	Possible Cause	Corrective Action
The engine will not start, starts hard, or fails to keep running.	<ol style="list-style-type: none"> <li>1. The fuel tank is empty or shut-off valve closed.</li> <li>2. The spark plug wire is loose or disconnected.</li> <li>3. The spark plug is pitted, fouled, or the gap is incorrect.</li> <li>4. The air cleaner is dirty.</li> <li>5. There is dirt in the fuel filter.</li> <li>6. There is dirt, water, or stale fuel in the fuel system.</li> <li>7. The gap between the safety interlock switches is not correct.</li> </ol>	<ol style="list-style-type: none"> <li>1. Fill fuel tank with gasoline and open valve</li> <li>2. Install wire on spark plug.</li> <li>3. Install a new, correctly gapped spark plug.</li> <li>4. Service the air cleaner element.</li> <li>5. Replace the fuel filter.</li> <li>6. Contact an Authorized Service Dealer.</li> <li>7. Contact an Authorized Service Dealer.</li> </ol>
The engine loses power.	<ol style="list-style-type: none"> <li>1. The engine load is excessive.</li> <li>2. The air cleaner is dirty.</li> <li>3. The oil level in the crankcase is low.</li> <li>4. The cooling fins and air passages above the engine are plugged.</li> <li>5. The vent hole in the fuel cap is plugged.</li> <li>6. Dirt is in the fuel filter.</li> <li>7. Dirt, water, or stale fuel is in the fuel system.</li> </ol>	<ol style="list-style-type: none"> <li>1. Reduce the ground speed.</li> <li>2. Clean the air cleaner element.</li> <li>3. Add oil to the crankcase.</li> <li>4. Remove the obstruction from the cooling fins and air passages.</li> <li>5. Clean or replace the fuel cap.</li> <li>6. Replace the fuel filter.</li> <li>7. Contact an Authorized Service Dealer.</li> </ol>
The engine overheats.	<ol style="list-style-type: none"> <li>1. The engine load is excessive.</li> <li>2. The oil level in the crankcase is low.</li> <li>3. The cooling fins and air passages above the engine are plugged.</li> </ol>	<ol style="list-style-type: none"> <li>1. Reduce the ground speed.</li> <li>2. Add oil to the crankcase.</li> <li>3. Remove the obstruction from the cooling fins and air passages.</li> </ol>
The machine does not drive.	<ol style="list-style-type: none"> <li>1. The by pass valve is not closed tight.</li> <li>2. The drive or pump belt is worn, loose or broken.</li> <li>3. The drive or pump belt is off a pulley.</li> <li>4. The idler spring is broken or missing.</li> <li>5. The hydraulic fluid level is low or too hot.</li> </ol>	<ol style="list-style-type: none"> <li>1. Tighten the by pass valve.</li> <li>2. Change the belt.</li> <li>3. Change the belt.</li> <li>4. Replace the spring.</li> <li>5. Add hydraulic fluid to the reservoir or let it cool down.</li> </ol>
There is an abnormal vibration.	<ol style="list-style-type: none"> <li>1. The cutting blade(s) is/are bent or unbalanced.</li> <li>2. The blade mounting bolt is loose.</li> <li>3. The engine mounting bolts are loose.</li> <li>4. The engine pulley, idler pulley, or blade pulley is loose.</li> <li>5. The engine pulley is damaged.</li> <li>6. The blade spindle is bent.</li> <li>7. The motor mount is loose or worn.</li> </ol>	<ol style="list-style-type: none"> <li>1. Install new cutting blade(s).</li> <li>2. Tighten the blade mounting bolt.</li> <li>3. Tighten the engine mounting bolts.</li> <li>4. Tighten the appropriate pulley.</li> <li>5. Contact an Authorized Service Dealer.</li> <li>6. Contact an Authorized Service Dealer.</li> <li>7. Contact an Authorized Service Dealer.</li> </ol>
The machine is producing an uneven cutting height.	<ol style="list-style-type: none"> <li>1. The cutting blade(s) is/are not sharp.</li> <li>2. The cutting blade(s) is/are bent.</li> <li>3. The mower deck is not level.</li> <li>4. The underside of mower is dirty.</li> <li>5. The tire pressure is not correct.</li> <li>6. The blade spindle is bent.</li> </ol>	<ol style="list-style-type: none"> <li>1. Sharpen the blade(s).</li> <li>2. Install new cutting blade(s).</li> <li>3. Level the mower deck from side-to-side and front-to-rear.</li> <li>4. Clean the underside of the mower.</li> <li>5. Adjust the tire pressure.</li> <li>6. Contact an Authorized Service Dealer.</li> </ol>

Problem	Possible Cause	Corrective Action
The cutting blades do not rotate.	<ol style="list-style-type: none"> <li>1. The drive belt is worn, loose or broken.</li> <li>2. The drive belt is off pulley.</li> <li>3. The mower deck belt is worn, loose or broken.</li> <li>4. The mower deck belt came off a pulley.</li> <li>5. The idler spring is broken or missing.</li> </ol>	<ol style="list-style-type: none"> <li>1. Check the belt tension.</li> <li>2. Install the drive belt and check the adjusting shafts and belt guides for correct position.</li> <li>3. Install a new mower deck belt.</li> <li>4. Install the mower deck belt and check the idler pulley, idler arm, and spring for the correct position and function.</li> <li>5. Replace the spring.</li> </ol>
The malfunction Indicator Light (MIL) comes on.	<ol style="list-style-type: none"> <li>1. The engine is too hot.</li> <li>2. There is old gas in the gas tank.</li> <li>3. The fuel shut-off valve is not open completely.</li> <li>4. The air cleaner is dirty.</li> <li>5. The battery is not charged.</li> <li>6. Incorrect fuel filters are being used or the fuel filters are dirty.</li> <li>7. The connections to the sensors electronic control unit (ECU) and fuel injectors are not secured properly.</li> <li>8. There is low voltage from the battery.</li> <li>9. A fuse is blown.</li> </ol>	<ol style="list-style-type: none"> <li>1. Turn the engine off and let it cool.</li> <li>2. Use new gas.</li> <li>3. Open the fuel shut-off valve.</li> <li>4. Make sure that the air cleaner and precleaner are clean. Replace if necessary.</li> <li>5. Charge or replace the battery.</li> <li>6. Contact an Authorized Service Dealer.</li> <li>7. Contact an Authorized Service Dealer.</li> <li>8. Ensure a good 12 volt battery is being used and is fully charged.</li> <li>9. Check and replace any blown fuses.</li> </ol>

# Schematics

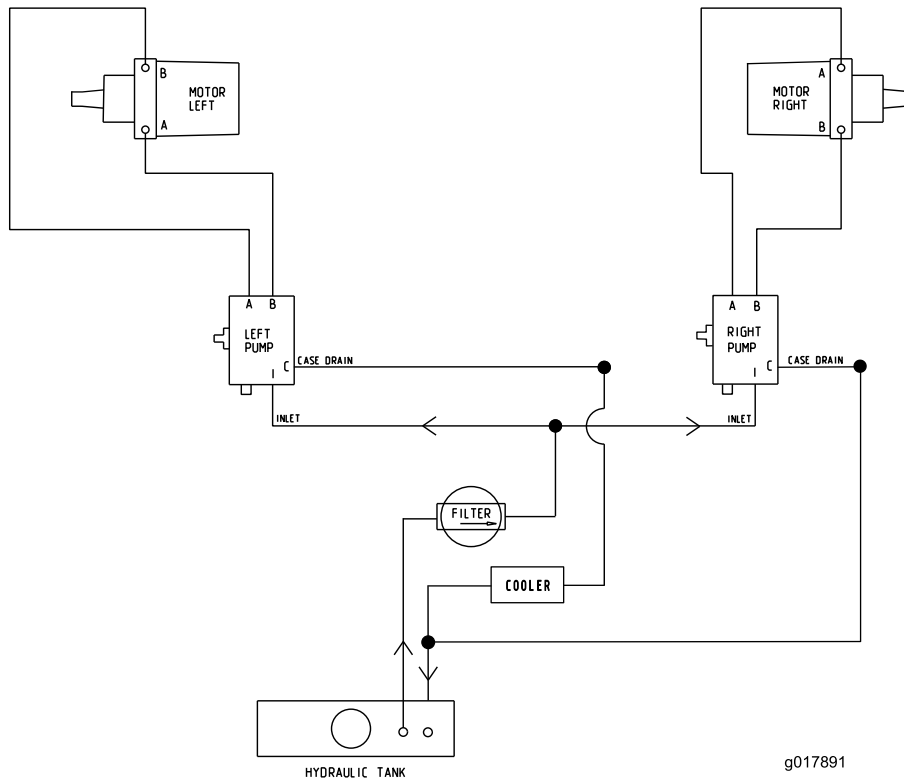

g017891

**Hydraulic Schematic (Rev. A)**

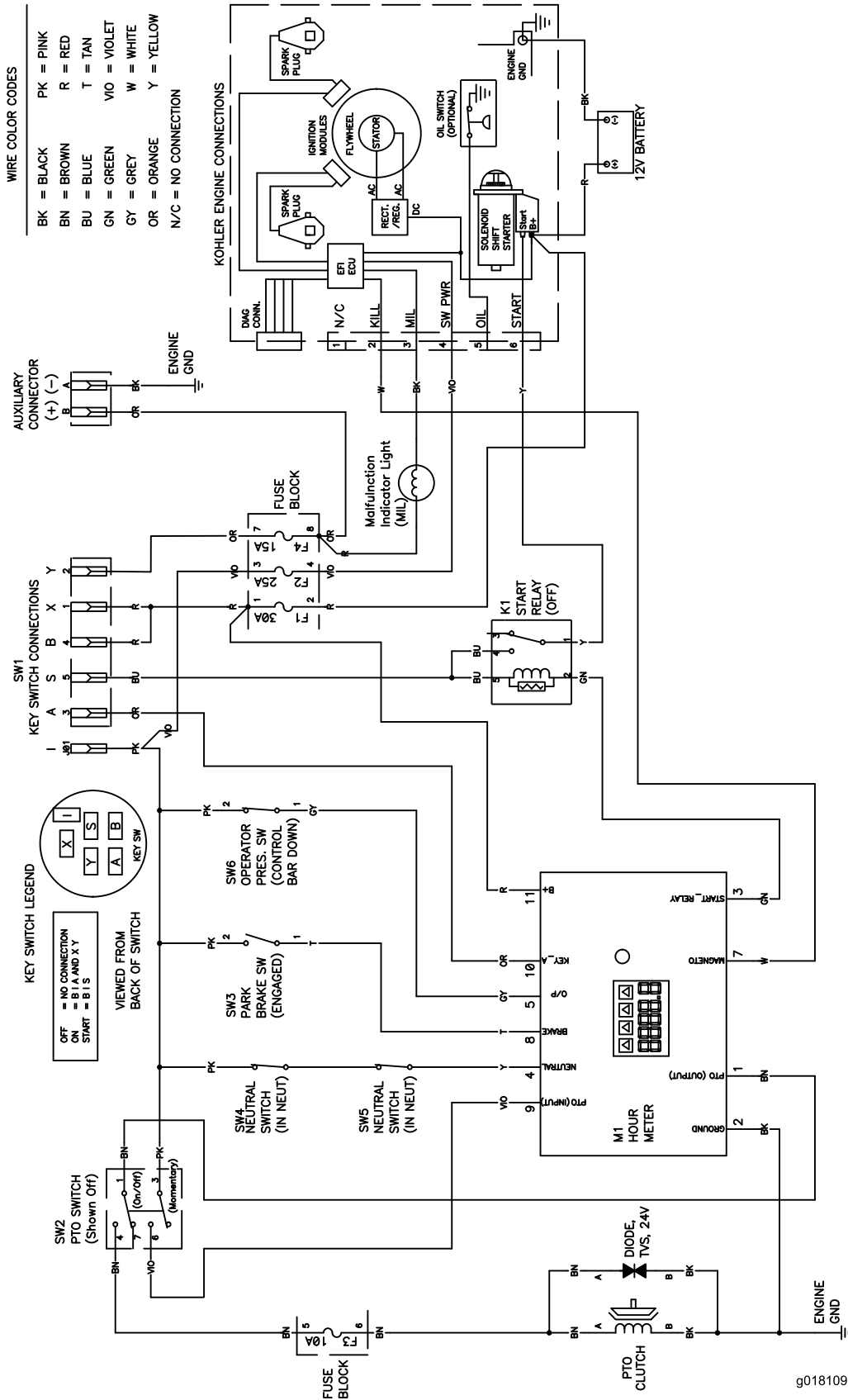

Electrical Schematic (Rev. A)

g018109



# The Toro Total Coverage Warranty

A Limited Warranty (see warranty periods below)

Landscape Contractor Equipment (LCE)

## Conditions and Products Covered

The Toro Company and its affiliate, Toro Warranty Company, pursuant to an agreement between them, jointly promise to the original purchaser to repair the Toro Products listed below if defective in materials or workmanship.

The following time periods apply from the date of purchase by the original owner:

Products	Warranty Period
21 in. Mowers	2 years Residential Use <sup>1</sup> 1 year Commercial Use
• Engines <sup>4</sup>	Honda – 2 years Kawasaki – 3 years
30 in. Mowers	2 years Residential Use <sup>1</sup> 1 year Commercial Use
• Engines <sup>4</sup>	Kawasaki – 3 years
Mid-Size Walk-Behind Mowers	2 years
• Engines <sup>4</sup>	Kawasaki – 3 years
Grand Stand® Mowers	5 years or 1,200 hours <sup>2</sup>
• Engines <sup>4</sup>	3 years
• Frame	Lifetime (original owner only) <sup>3</sup>
Z Master® 2000 Series Mowers	4 years or 500 hours <sup>2</sup>
• Engines <sup>4</sup>	3 years
• Frame	Lifetime (original owner only) <sup>3</sup>
Z Master® 3000 Series Mowers	5 years or 1,200 hours <sup>2</sup>
• Engines <sup>4</sup>	3 years
• Frame	Lifetime (original owner only) <sup>3</sup>
Z Master® 5000 Series Mowers	5 years or 1,200 hours <sup>2</sup>
• Engines <sup>4</sup>	Kohler Command – 2 years Kohler EFI – 3 years
• Frame	Lifetime (original owner only) <sup>3</sup>
Z Master® 6000 Series Mowers	5 years or 1,200 hours <sup>2</sup>
• Engines <sup>4</sup>	Kawasaki – 3 years
• Frame	Lifetime (original owner only) <sup>3</sup>
Z Master®7000 Series Mowers	5 years or 1,200 hours <sup>2</sup>
• Engines <sup>4</sup>	2 years
• Frame	Lifetime (original owner only) <sup>3</sup>
All Mowers	
• Battery	90 days Parts and Labor 1 year Parts only
• Belts and Tires	90 days
• Attachments	1 year

<sup>1</sup>Residential use means use of the product on the same lot as your home. Use at more than one location is considered commercial use and the commercial warranty would apply.

<sup>2</sup>Whichever occurs first.

<sup>3</sup>Lifetime Frame Warranty - If the main frame, consisting of the parts welded together to form the tractor structure that other components such as the engine are secured to, cracks or breaks in normal use, it will be repaired or replaced, at Toro's option, under warranty at no cost for parts and labor. Frame failure due to misuse or abuse and failure or repair required due to rust or corrosion are not covered.

<sup>4</sup>Some engines used on Toro Products are warranted by the engine manufacturer.

## Instructions for Obtaining Warranty Service

If you think that your Toro Product contains a defect in materials or workmanship, follow this procedure:

1. Contact any Authorized Toro Service Dealer to arrange service at their dealership. To locate a dealer convenient to you, refer to the Yellow Pages of your telephone directory (look under "Lawn Mowers") or access our web site at [www.Toro.com](http://www.Toro.com). You may also call the numbers listed in item #3 to use the 24-hour Toro Dealer locator system.
2. Bring the product and your proof of purchase (sales receipt) to the Service Dealer. The dealer will diagnose the problem and determine if it is covered under warranty.
3. If for any reason you are dissatisfied with the Service Dealer's analysis or with the assistance provided, contact us at:

RLC Customer Care Department  
Toro Warranty Company  
8111 Lyndale Avenue South  
Bloomington, MN 55420-1196  
888-865-5676 (U.S. Customers)  
888-865-5691 (Canada customers)

## Owner Responsibilities

You must maintain your Toro Product by following the maintenance procedures described in the *Operator's Manual*. Such routine maintenance, whether performed by a dealer or by you, is at your expense.

## Items and Conditions Not Covered

There is no other express warranty except for special emission system coverage and engine warranty coverage on some products. This express warranty does not cover the following:

- Cost of regular maintenance service or parts, such as filters, fuel, lubricants, oil changes, spark plugs, air filters blade sharpening or worn blades, cable/linkage adjustments, or brake and clutch adjustments
- Components failing due to normal wear
- Any product or part which has been altered or misused or neglected and requires replacement or repair due to accidents or lack of proper maintenance
- Pickup and delivery charges
- Repairs or attempted repairs by anyone other than an Authorized Toro Service Dealer
- Repairs necessary due to failure to follow recommended fuel procedure (consult *Operator's Manual* for more details)
  - Removing contaminants from the fuel system is not covered
  - Use of old fuel (more than one month old) or fuel which contains more than 10% ethanol or more than 15% MTBE
  - Failure to drain the fuel system prior to any period of non-use over one month

## General Conditions

All repairs covered by these warranties must be performed by an Authorized Toro Service Dealer using Toro approved replacement parts.

**Neither The Toro Company nor Toro Warranty Company is liable for indirect, incidental or consequential damages in connection with the use of the Toro Products covered by this warranty, including any cost or expense of providing substitute equipment or service during reasonable periods of malfunction or non-use pending completion of repairs under this warranty.**

**All implied warranties of merchantability (that the product is fit for ordinary use) and fitness for use (that the product is fit for a particular purpose) are limited to the duration of the express warranty.**

**Some states do not allow exclusions of incidental or consequential damages, or limitations on how long an implied warranty lasts, so the above exclusions and limitations may not apply to you.**

This warranty gives you specific legal rights, and you may also have other rights which vary from state to state.

## Countries Other than the United States or Canada

Customers who have purchased Toro products outside the United States or Canada should contact their Toro Distributor (Dealer) to obtain guarantee policies for your country, province, or state. If for any reason you are dissatisfied with your Distributor's service or have difficulty obtaining guarantee information, contact the Toro importer. If all other remedies fail, you may contact us at Toro Warranty Company.