



**Count on it.**

**Parts Catalog**

**Sand Pro® 3040 Traction Unit**

Model No. 08703—Serial No. 314000001 and Up



# Ordering Replacement Parts

To order replacement parts, please supply the part number, the quantity, and the description of each part desired.

## Understanding Reference Numbers

Each identified part in an illustration has a reference number. The reference number for a part also appears in the parts list, along with other information about the part.

This catalog uses two special reference number formats, one to indicate parts in a service assembly and another to indicate the quantity of a given part in an illustration.

## Service Assembly Reference Numbers

Parts in service assemblies have reference numbers in the form a:b. The a represents the reference number of the entire service assembly and the b represents a sequential number unique to each part within the service assembly.

For example, a wheel assembly might be identified by reference number 6, the tire by 6:1, the valve by 6:2, and the wheel by 6:3. When you order the assembly identified by reference number 6, you receive all parts identified by reference numbers 6:1, 6:2, and 6:3. However, you may also order any part individually. Reference numbers of this type appear in illustration and in parts lists.

## Reference Numbers Indicating Quantity

In an illustration, if a reference number indicates more than one part, the reference number has the form nX y. The n represents the quantity of the part, the X is the multiplication symbol, and the y represents the reference number.

For example, in an illustration, the reference number 2X 37 means that two of the parts identified by reference number 37 are indicated.

# List of Abbreviations

**AR:** as required

**ASM:** assembly

**BBC:** blade brake control

**BHTF:** button head thread forming

**CARR:** carriage

**CCW:** counter clockwise

**CW:** clockwise

**DEG:** degrees

**DPA:** Dual Point Adjustment

**ECM:** electronic control module

**EXT:** external

**FH:** flat head

**GA:** gauge

**HD:** heavy-duty

**HF:** hex flange

**HH:** hex head

**HHF:** hex head flange

**HHFTF:** hex head flange thread forming

**HJ:** hex jam

**HLH:** hex lag head

**HOC:** height-of-cut

**HSBH:** hex socket button head

**HSFH:** hex socket flat head

**HSH:** hex socket head

**HWH:** hex washer head

**HWHTF:** hex washer head thread forming

**HYD:** hydraulic

**LH:** left hand

**LP:** Liquefied Petroleum Gas

**LPG:** Liquefied Petroleum Gas

**NI:** nylon insert

**NPTF:** national pipe thread fine

**PFH:** phillips flat head

**PPH:** phillips pan head

**PPHTF:** phillips pan head thread forming

**PRH:** phillips round head

**PTH:** phillips truss head

**PTO:** power-take-off

**RH:** right hand

**ROPS:** roll-over protection system

**RRB:** rear roller brush

**SFH:** slotted fillister head

**SHH:** slotted hex head

**SHWH:** slotted hex washer head

**SPH:** slotted pan head

**SQH:** square head

**SRH:** slotted round head

**STD:** standard

**TAP:** self tapping

**TTH:** torx truss head

# Contents

Frame and Console Assembly .....	4
Steering Assembly .....	5
Steering Box Assembly No. 107-3526 .....	6
Fuel Tank and Battery Assembly .....	7
Front Wheel Assembly .....	9
Hydraulic Motor Assembly No. 108-2948 .....	10
Rear Wheel Assembly .....	11
Hydraulic Motor Assembly No. 108-2947 .....	12
Hydraulic Motor Assembly No. 108-2949 .....	13
Traction Pedal Assembly .....	14
Pump Control Lever Assembly .....	15
Engine Installation Assembly .....	16
Pump and Coupling Assembly .....	17
Variable Piston Pump Assembly No. 114-0612 .....	18
Hydraulic Tank, Filter and Cooler Assembly .....	20
Lift Valve and Rear Tube Assembly .....	21
Seat and Shroud Assembly .....	23
Wire Harness, Air Cleaner and Hose Assembly .....	24
Air Cleaner Assembly No. 93-2190 .....	25
Rear Hitch Assembly .....	26
Hydraulic Lift Cylinder Assembly No. 115-5647 .....	27
Attachments and Accessories .....	28

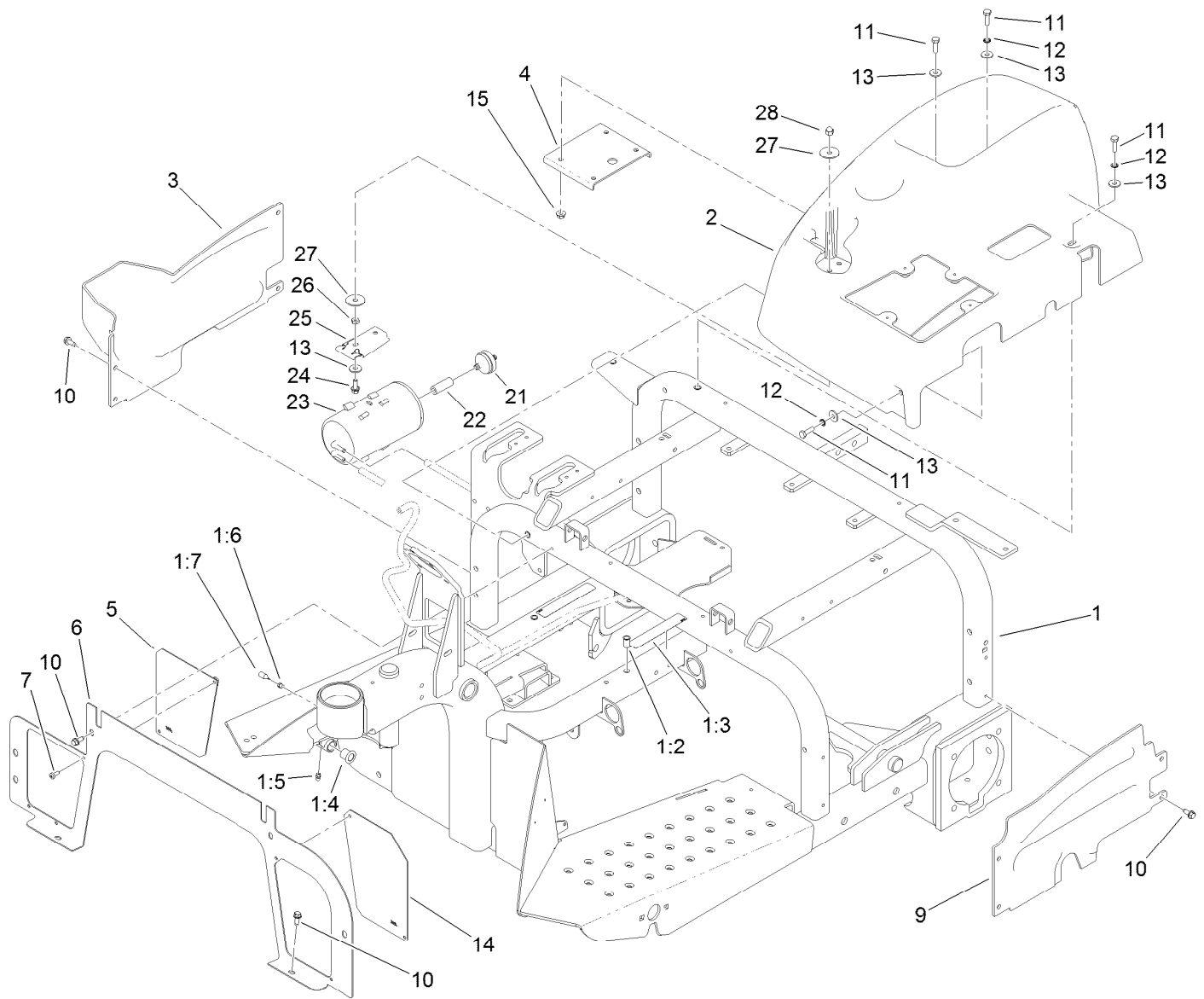

## Frame and Console Assembly

<i>Ref.</i>	<i>Part Number</i>	<i>Qty.</i>	<i>Description</i>	<i>Ref.</i>	<i>Part Number</i>	<i>Qty.</i>	<i>Description</i>
1	110-3367	1	Frame ASM	10	32144-10	12	Screw-HWH
1:2	32148-11	5	Insert-Threaded	11	321-5	7	Screw-HH
1:3	93-7272	2	Decal-Warning	12	3254-8	3	Washer-Lock
1:4	256-219	2	Bushing	13	3256-78	8	Washer-Flat
1:5	302-58	1	Fitting-Straight	14	120-3491-01	1	Screen-Panel, LH
1:6	107-1997	1	Fitting-Grease	15	32128-33	4	Nut-HF
1:7	107-1998	1	Nozzle-Grease	21	115-7854	1	Filter-Fuel, Inline
2	108-2936	1	Console	22	106-5317	1	Hose-Fuel
3	108-6855	1	Shroud-Wheel, RH	23	115-2251	1	Canister-Carbon
4	108-7995-03	1	Plate-Support, Console	24	3234-33	1	Screw-HHF
5	120-3492-01	1	Screen-Panel, RH	25	114-0292	1	Bracket-Canister, Carbon
6	112-1443-01	1	Panel-Front	26	3218-1	1	Nut-Jam
7	3250-14	4	Screw-PPH	27	3256-57	2	Washer-Flat
9	108-6856	1	Shroud-Wheel, LH	28	32111-7	1	Nut-Cap

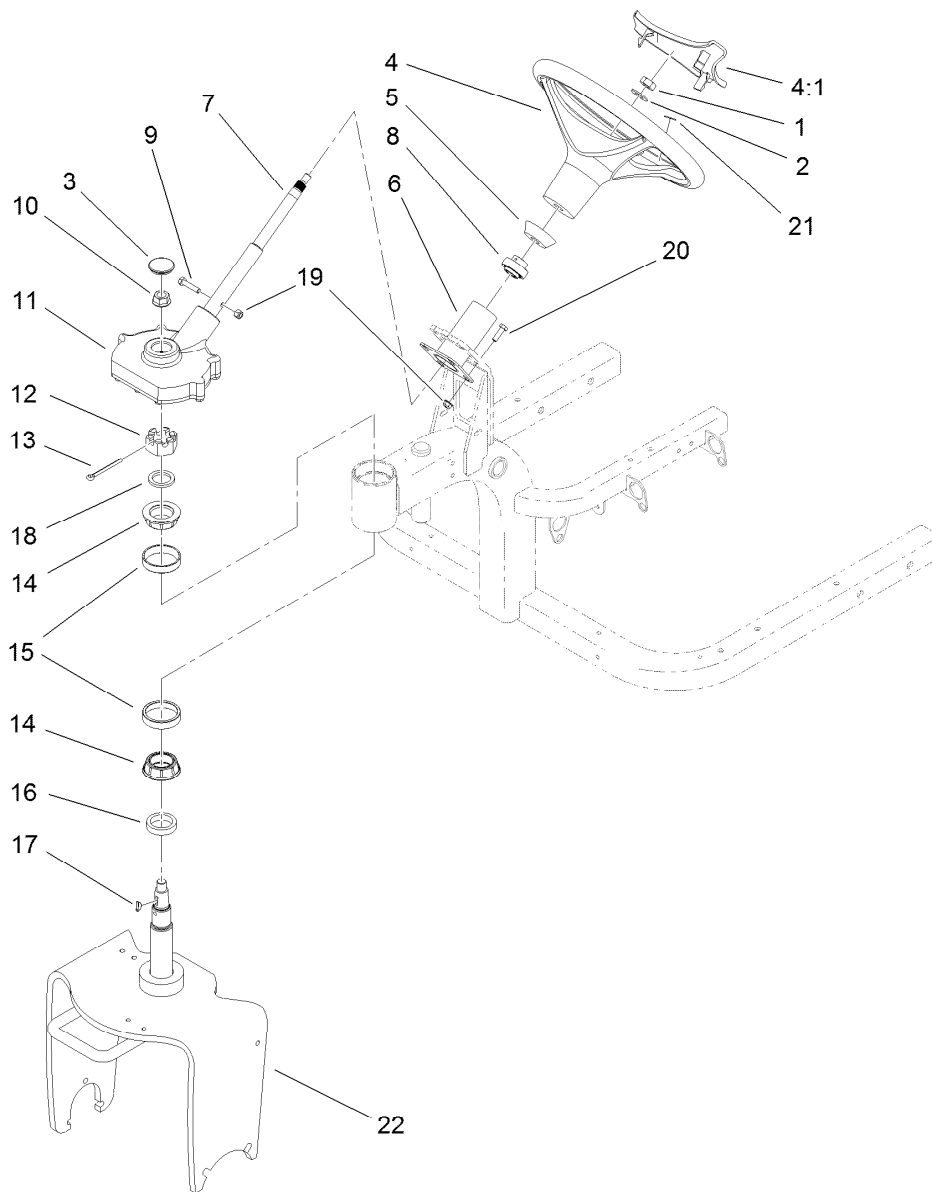

## Steering Assembly

<i>Ref.</i>	<i>Part Number</i>	<i>Qty.</i>	<i>Description</i>	<i>Ref.</i>	<i>Part Number</i>	<i>Qty.</i>	<i>Description</i>
1	3296-33	1	Nut-Lock, NI	12	32136-9	1	Nut-Hex, Slotted
2	3256-27	1	Washer-Flat	13	3272-37	1	Pin-Cotter
3	107-3532	1	Grommet	14	107-7589	2	Cone-Bearing (W/ Seal)
4	98-1471	1	Wheel-Steering	15	107-7590	2	Cup-Bearing
4:1	98-1468	1	Cover-Wheel, Steering	16	108-5432	1	Spacer-Bearing
5	93-5429	1	Collar-Foam	17	3257-5	1	Key-Woodruff
6	107-3540-03	1	Tube	18	115-5639	1	Washer-Steering
7	107-3533	1	Shaft-Steering	19	104-8300	5	Nut-Flange, NI
8	106-8448	1	Bearing-Race, Extended	20	322-5	4	Screw-HH
9	322-7	1	Screw-HH	21	98-1459	1	Decal
10	32128-54	1	Nut-HF	22	107-3543-01	1	Fork ASM
11	107-3526	1	Steering Box ASM				

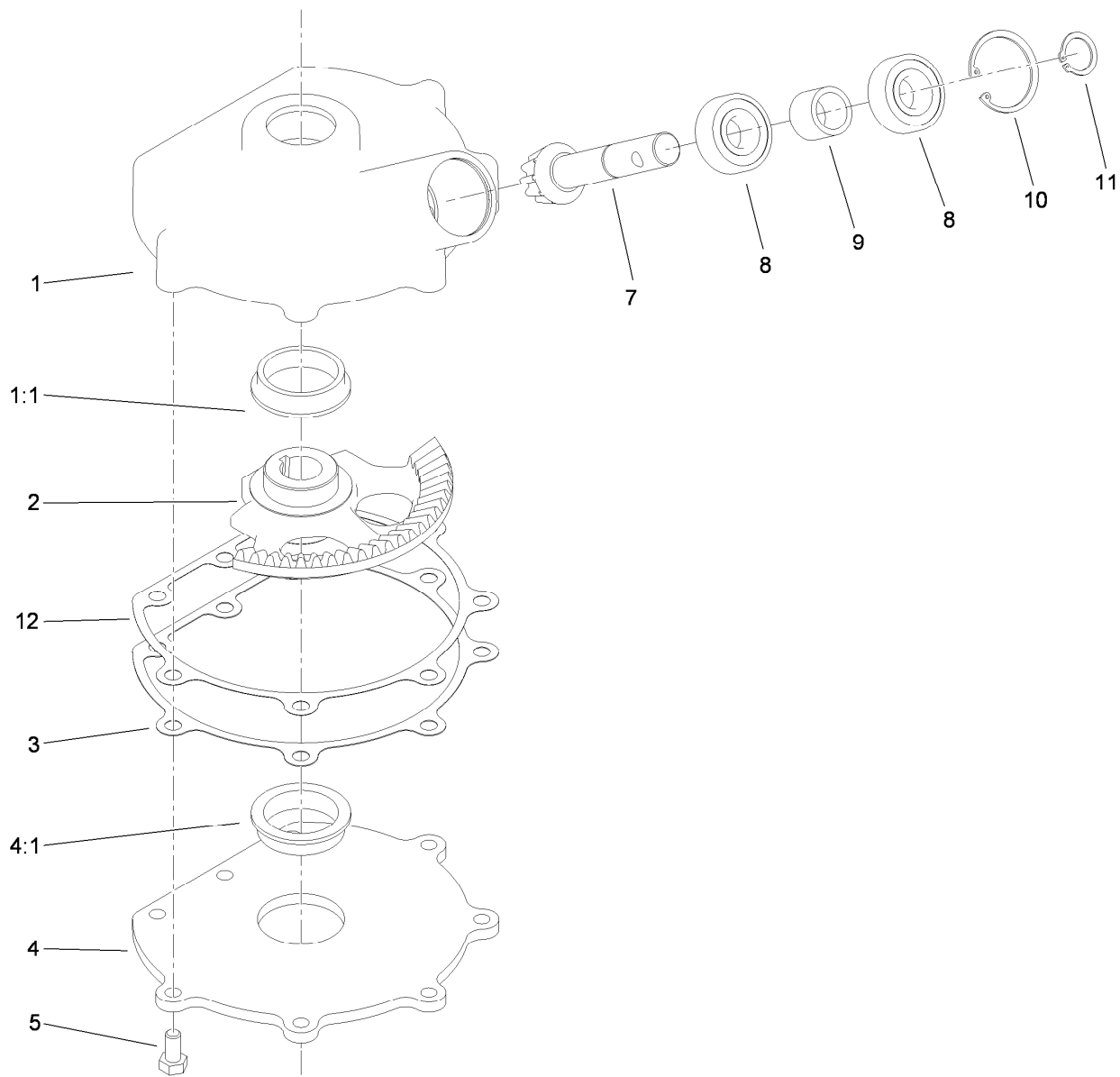

## Steering Box Assembly No. 107-3526

Ref.	Part Number	Qty.	Description
1	108-4520	1	Steering Cover ASM
1:1	92-6869	1	Bushing
2	107-3520	1	Gear-Sector
3	107-3529	1	Gasket-Steering
4	107-3524	1	Steering Plate ASM
4:1	92-6869	1	Bushing
5	322-2	8	Screw-HH
7	107-3527	1	Gear-Pinion
8	38-7820	2	Bearing-Ball
9	108-4502	1	Spacer
10	107-3530	1	Ring-Retaining
11	32151-12	1	Ring-Retaining
12	108-8442	3	Shim-Plate, Steering

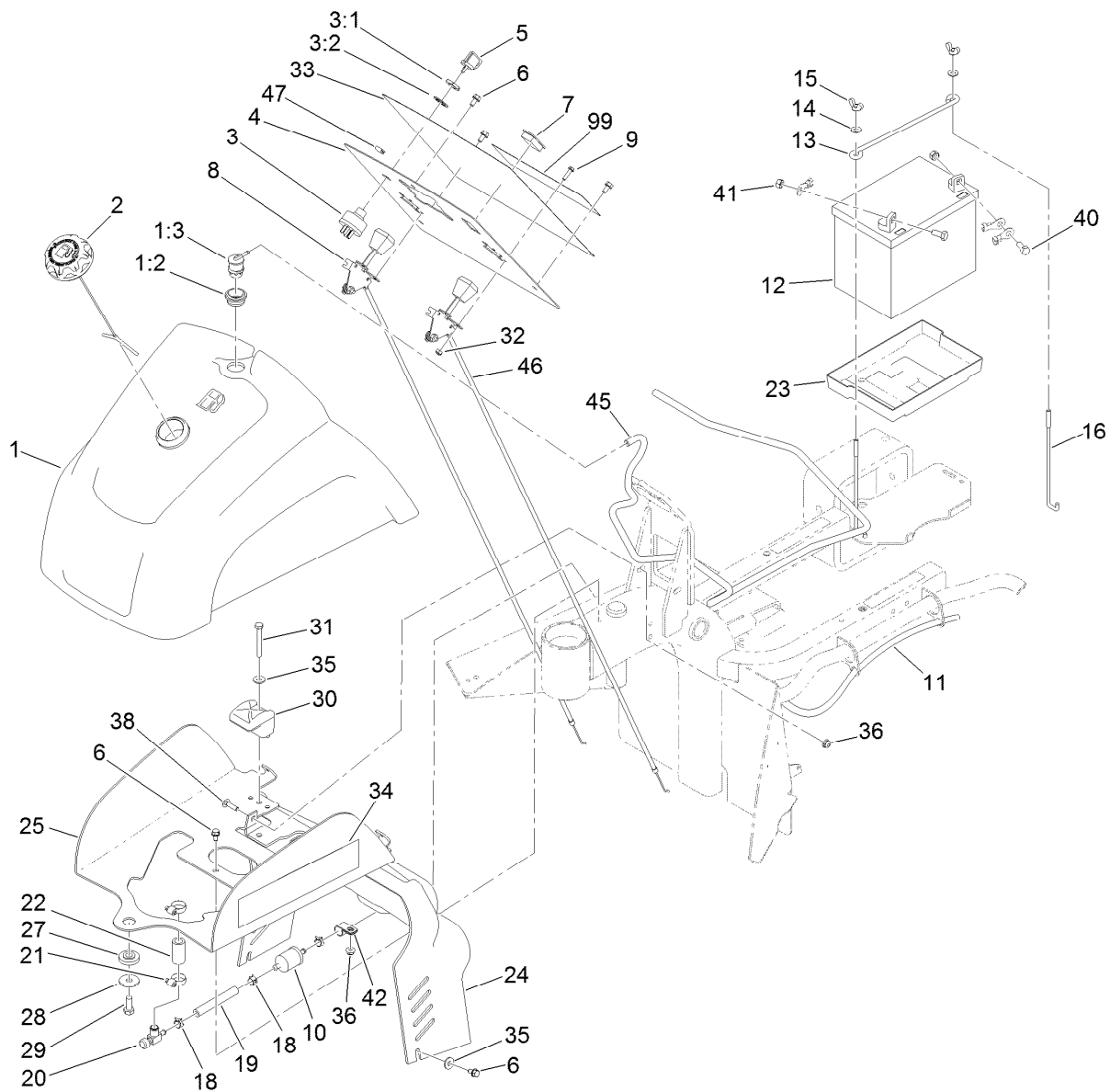

## Fuel Tank and Battery Assembly

Ref.	Part Number	Qty.	Description
1	119-2496	1	Fuel Tank ASM
1:2	114-0284	1	Grommet
1:3	114-0285	1	Valve-Rollover
2	126-1789	1	Cap-Fuel, Ratcheting
3	83-0020	1	Switch-Ignition
3:1	218-461	1	Nut-HH
3:2	3254-5	1	Washer-Tooth, Internal
4	108-6896-03	1	Panel-Dash
5	63-8360	2	Key-Ignition
6	32144-10	6	Screw-HWH
7	99-7420	1	Plug-Hole
8	119-7188	1	Throttle Cable ASM
9	3290-321	4	Screw-HWH
10	94-2690	1	Filter-Fuel
11	110-3372	1	Hose-Fuel
12	104-8162	1	Battery-Dry
13	100-6434	1	Rod-Hold Down, Battery
14	3256-22	2	Washer-Flat
15	32103-22	2	Nut-Wing
16	100-6435	2	Post-Battery
18	2412-98	4	Clamp-Hose

Ref.	Part Number	Qty.	Description
19	109-0660	1	Hose-Fuel
20	83-1390	1	Valve-Shut-Off, Fuel
21	2412-36	2	Clamp-Hose
22	110-3371	1	Hose-Fuel
23	106948	1	Tray-Battery
24	108-6898	1	Shroud-Dash
25	108-6895-01	1	Bracket-Mount, Tank
27	240-11	1	Bushing-Flange
28	63-8410	1	Washer
29	323-5	1	Screw-HH
30	107-4543	2	Clamp
31	321-18	2	Screw-HH
32	3296-2	4	Nut-Lock, NI
33	119-2483	1	Decal-Dash
34	108-8420	2	Decal
35	3256-78	4	Washer-Flat
36	104-7201	4	Nut-HF
38	3229-1	2	Bolt-CARR
40	322-3	2	Screw-HH
41	3217-6	2	Nut-Hex
42	92-6064	1	Clamp-R

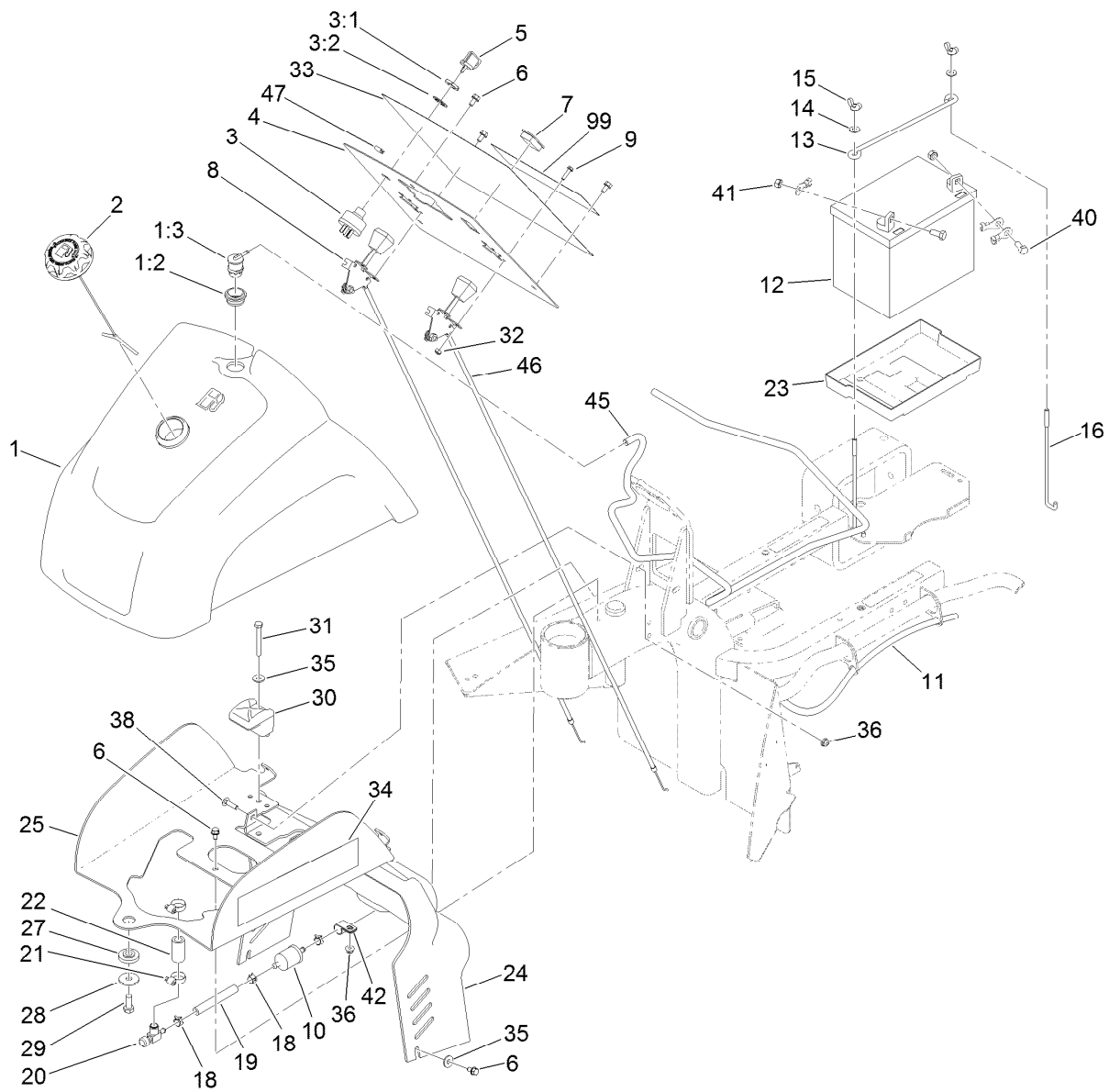

## Fuel Tank and Battery Assembly (continued)

Ref.	Part Number	Qty.	Description
45	117-9568	1	Hose-Vent, Tank
46	119-7178	1	Choke Cable ASM

Ref.	Part Number	Qty.	Description
47	119-2494	1	Seal-Strip
99	119-2484	1	Decal-Dash, C E



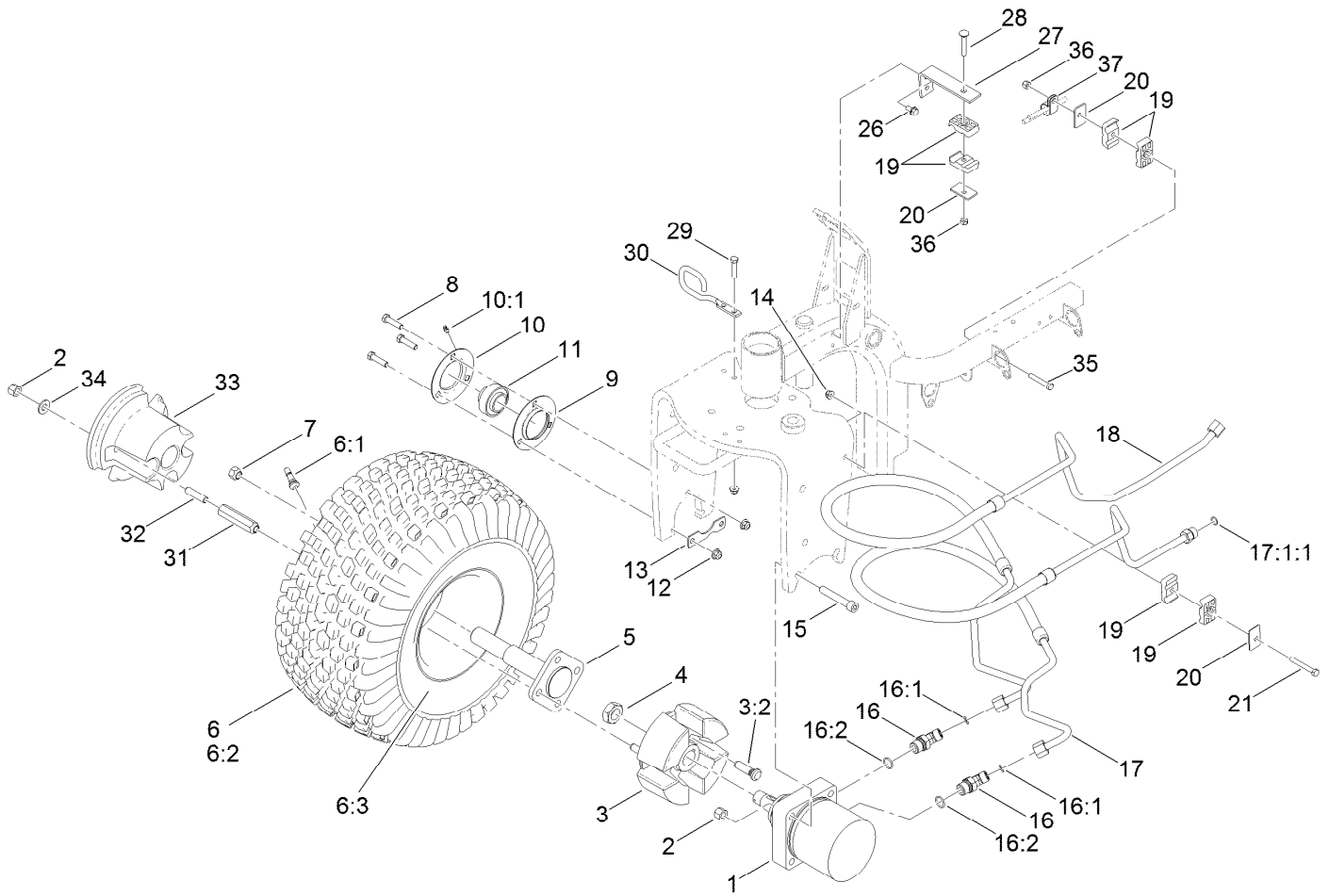

## Front Wheel Assembly

Ref.	Part Number	Qty.	Description	Ref.	Part Number	Qty.	Description
1	108-2948	1	HYD Motor ASM (CW)	16:1	237-30	1	O-Ring
2	3296-23	4	Nut-Lock, NI	16:2	237-80	1	O-Ring
3	110-6310	1	Front Wheel Hub ASM	17	119-6747	1	HYD Hose ASM
3:2	10-6830	4	Stud-Type, Drive	17:1:1	237-30	1	O-Ring
4	26-3790	1	Nut-Lock	18	119-6742	1	HYD Hose ASM
5	110-6314	1	Spindle	19	56-7976	6	Clamp-Tube
6	95-0621	1	Wheel And Tire ASM	20	69-9760	3	Coverplate
6:1	5108	1	Valve	21	322-12	1	Screw-HH
6:2	85-8290	1	Tire-2Ply, Knobby	26	32144-14	2	Screw-HWHTF
6:3	94-6116	1	Wheel-Rear	27	108-8455-01	1	Bracket-Clamp
7	242-50	2	Nut-Lug	28	3230-6	1	Screw-CARR
8	323-8	3	Screw-HH	29	322-7	2	Screw-HH
9	85-8950	1	Flangette-Standard	30	108-8435	1	Guide-Hose
10	85-8940	1	Flangette-Relube	31	107-3399	2	Adapter-Weight, Wheel
10:1	302-5	1	Fitting-Grease	32	110-6311	2	Stud
11	251-352	1	Bearing	33	110-6312-03	1	Weight
12	104-8301	3	Nut-Flange, NI	34	87-7270	2	Washer-Thrust
13	88-8350	1	Tab-Bearing	35	322-10	1	Screw-HH
14	104-8300	3	Nut-Flange, NI	36	3296-29	2	Nut-Lock, NI
15	3274-93	2	Screw-HSH	37	2412-41	1	Clamp
16	340-89	2	Fitting-HYD, 45 DEG				

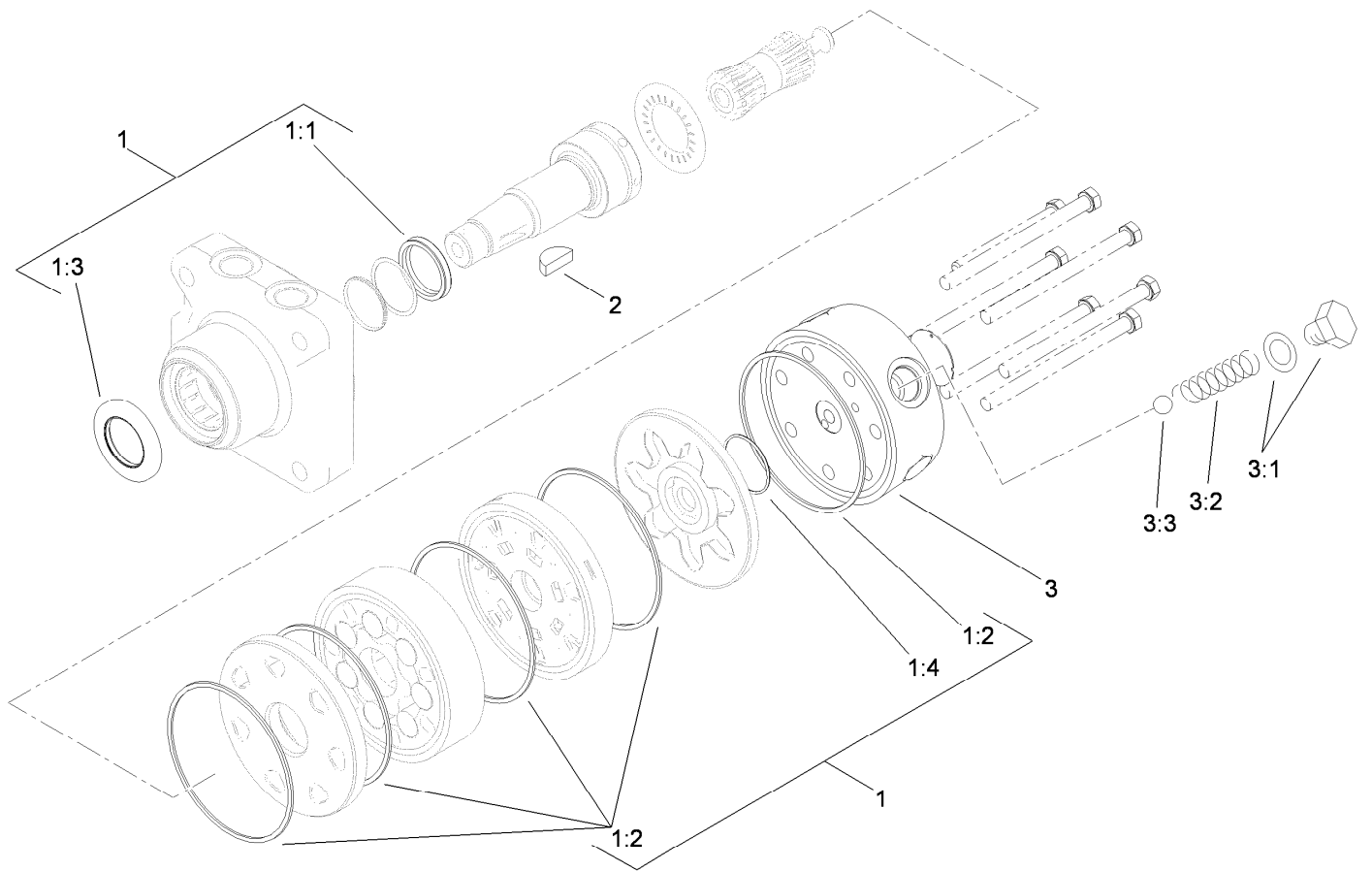

## Hydraulic Motor Assembly No. 108-2948

<i>Ref.</i>	<i>Part Number</i>	<i>Qty.</i>	<i>Description</i>
1	110-6459	1	Seal Kit
1:1		1	Seal-Shaft ●
1:2		5	Seal-Body ●
1:3		1	Seal-Dirt / Water ●
1:4		1	Seal-Commutator ●
2	3257-42	1	Key-Woodruff
3	99-3538	1	End Cover ASM
3:1		1	Spring Cap And O-Ring ASM ●
3:2	99-3541	1	Spring
3:3	99-3540	1	Ball

● Not serviced separately

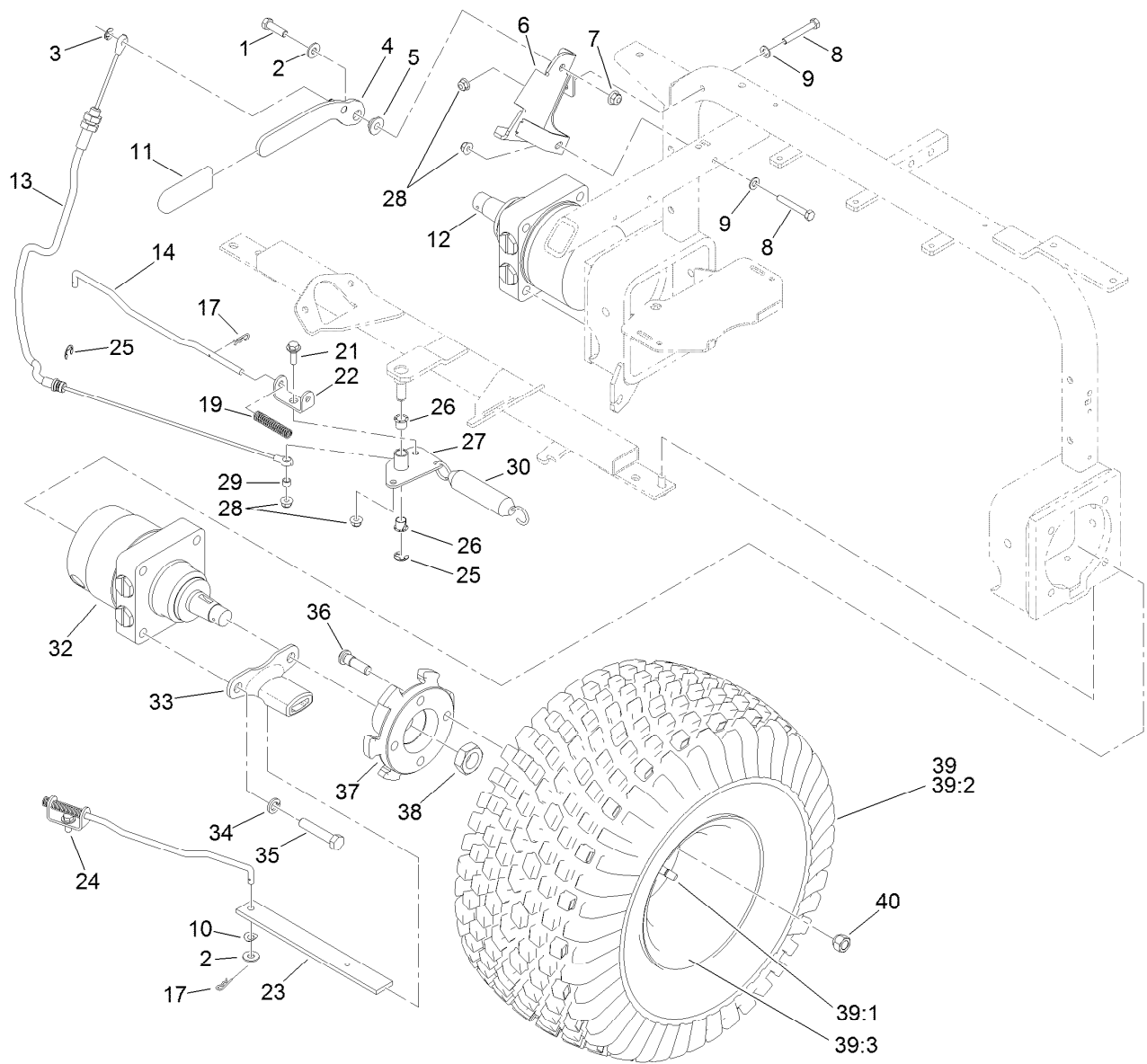

## Rear Wheel Assembly

Ref.	Part Number	Qty.	Description	Ref.	Part Number	Qty.	Description
1	323-7	1	Screw-HH	24	19-1470	1	Screw-Shoulder
2	3256-3	3	Washer-Flat	25	32120-47	2	Ring-Retaining, External
3	32151-47	1	Ring-Retaining	26	256-257	2	Bushing-Nyliner
4	108-7991-03	1	Lever-Brake	27	108-7979-03	1	Bellcrank
5	108-7994	1	Bushing-Pivot, Lever	28	104-8300	4	Nut-Flange, NI
6	121-2520	1	Brake Lever Bracket ASM	29	108-7983	1	Bushing-Cable
7	104-8301	1	Nut-Flange, NI	30	66-4270	1	Spring-Extension
8	322-11	2	Screw-HH	32	108-2947	1	HYD Motor ASM (CCW)
9	3256-23	2	Washer-Flat	33	125-1967	2	Bracket-Brake, Park
10	3290-301	2	Washer-Spring	34	3253-7	8	Washer-Lock
11	21-1880	1	Grip-Handle	35	325-10	8	Screw-HH
12	108-2949	1	HYD Motor ASM (CW)	36	85-6540	8	Stud-Drive
13	108-7913	1	Cable-Brake, Park	37	108-7977-03	2	Hub-Wheel
14	108-7987	2	Link-Latch, Parking	38	26-3790	2	Nut-Lock
17	3290-307	4	Pin-Hair	39	95-0621	2	Wheel And Tire ASM
19	107-3376	2	Spring-Compression	39:1	5108	1	Valve
21	19-1471	1	Screw-Shoulder	39:2	85-8290	1	Tire-2Ply, Knobby
22	114-0631	2	Clevis-Latch, Parking	39:3	94-6116	1	Wheel-Rear
23	108-7986-03	2	Bar-Brake	40	242-50	8	Nut-Lug

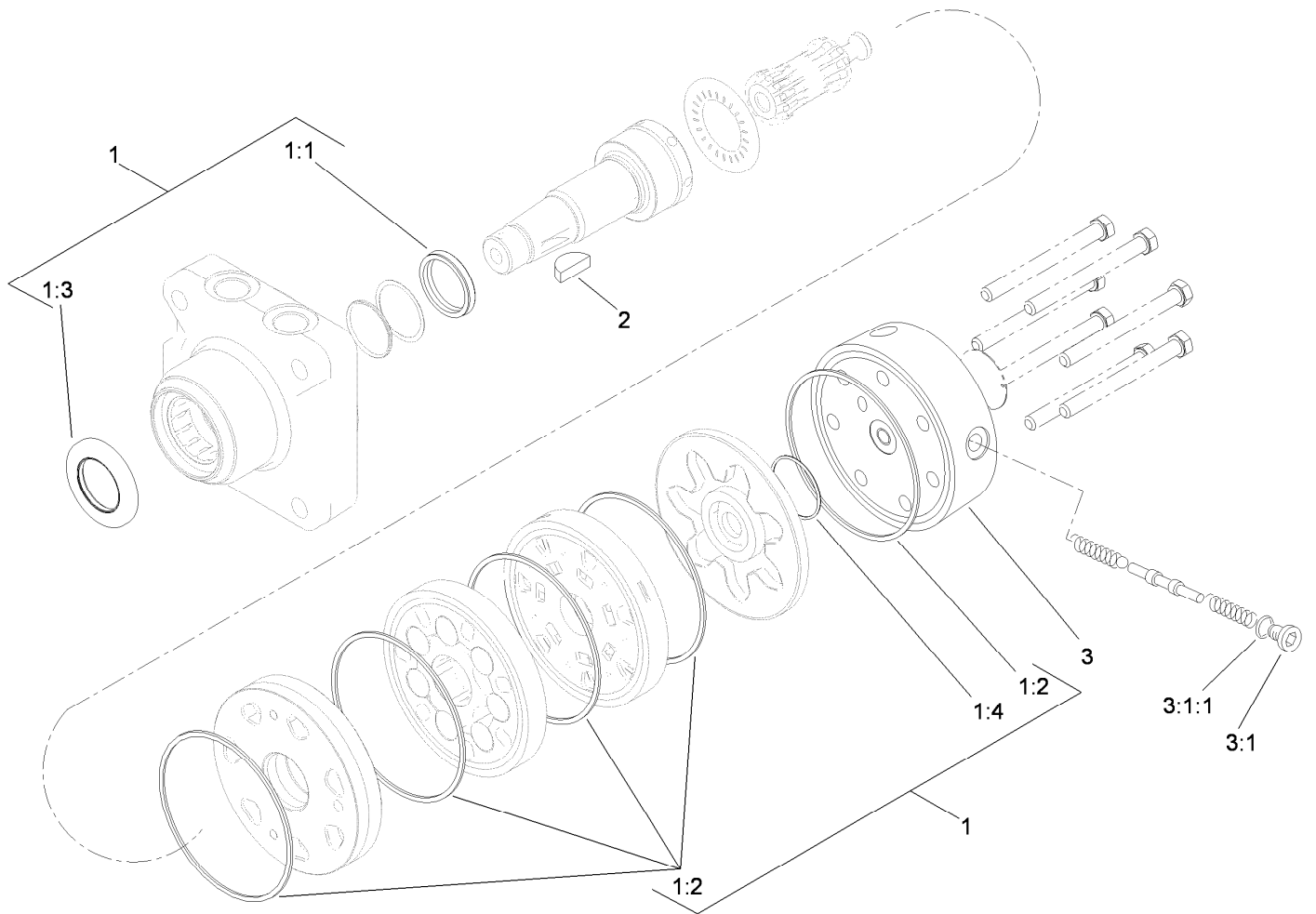

## Hydraulic Motor Assembly No. 108-2947

Ref.	Part Number	Qty.	Description
1	110-6459	1	Seal Kit
1:1		1	Seal-Shaft ●
1:2		5	Seal-Body ●
1:3		1	Seal-Dirt / Water ●
1:4		1	Seal-Commutator ●
2	3257-42	1	Key-Woodruff
3	110-3381	1	End Cover ASM
3:1	353-990	1	Plug ASM
3:1:1	237-78	1	O-Ring

● Not serviced separately

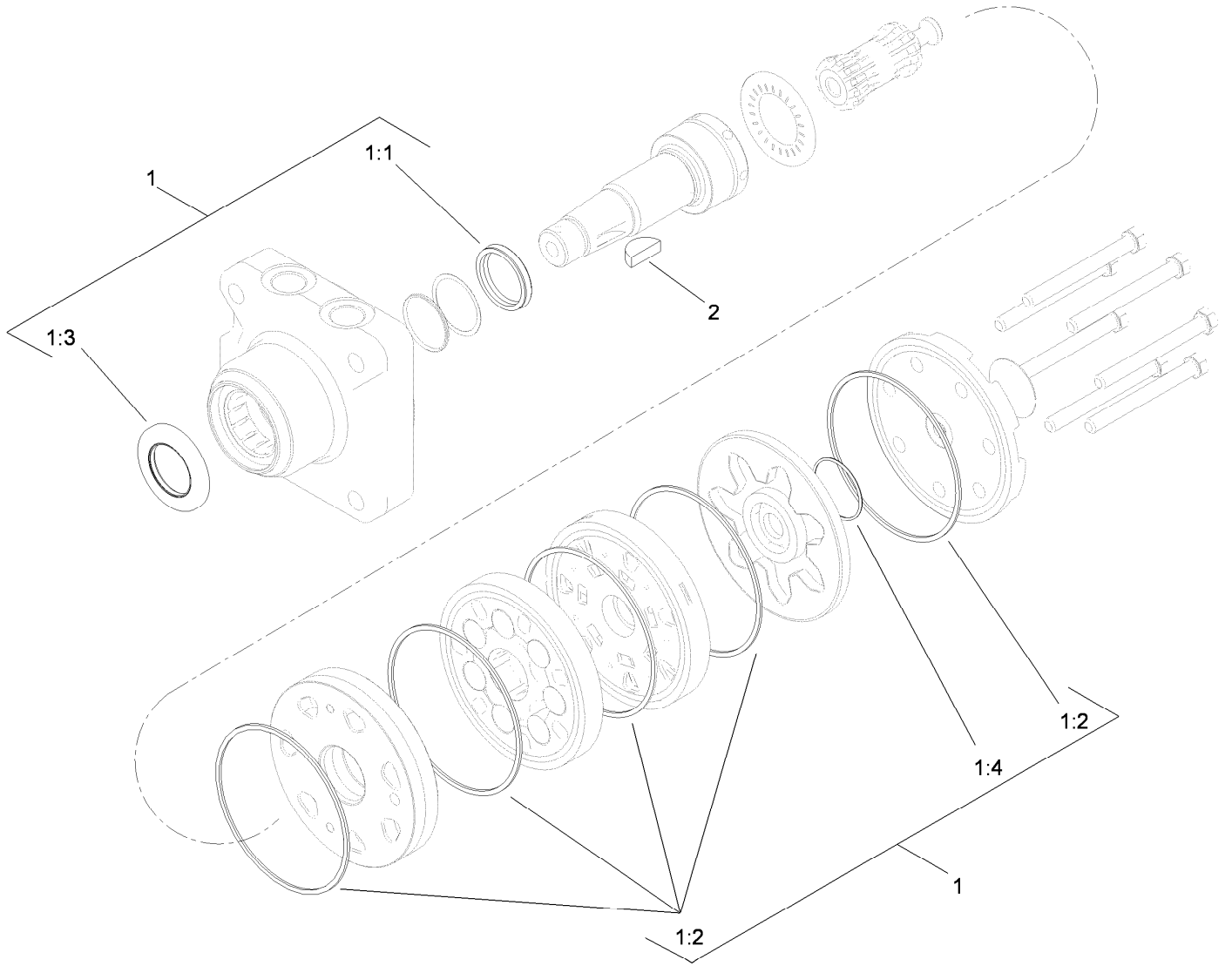

## Hydraulic Motor Assembly No. 108-2949

<i>Ref.</i>	<i>Part Number</i>	<i>Qty.</i>	<i>Description</i>
1	110-6459	1	Seal Kit
1:1		1	Seal-Shaft ●
1:2		5	Seal-Body ●
1:3		1	Seal-Dirt / Water ●
1:4		1	Seal-Commutator ●
2	3257-42	1	Key-Woodruff

● Not serviced separately

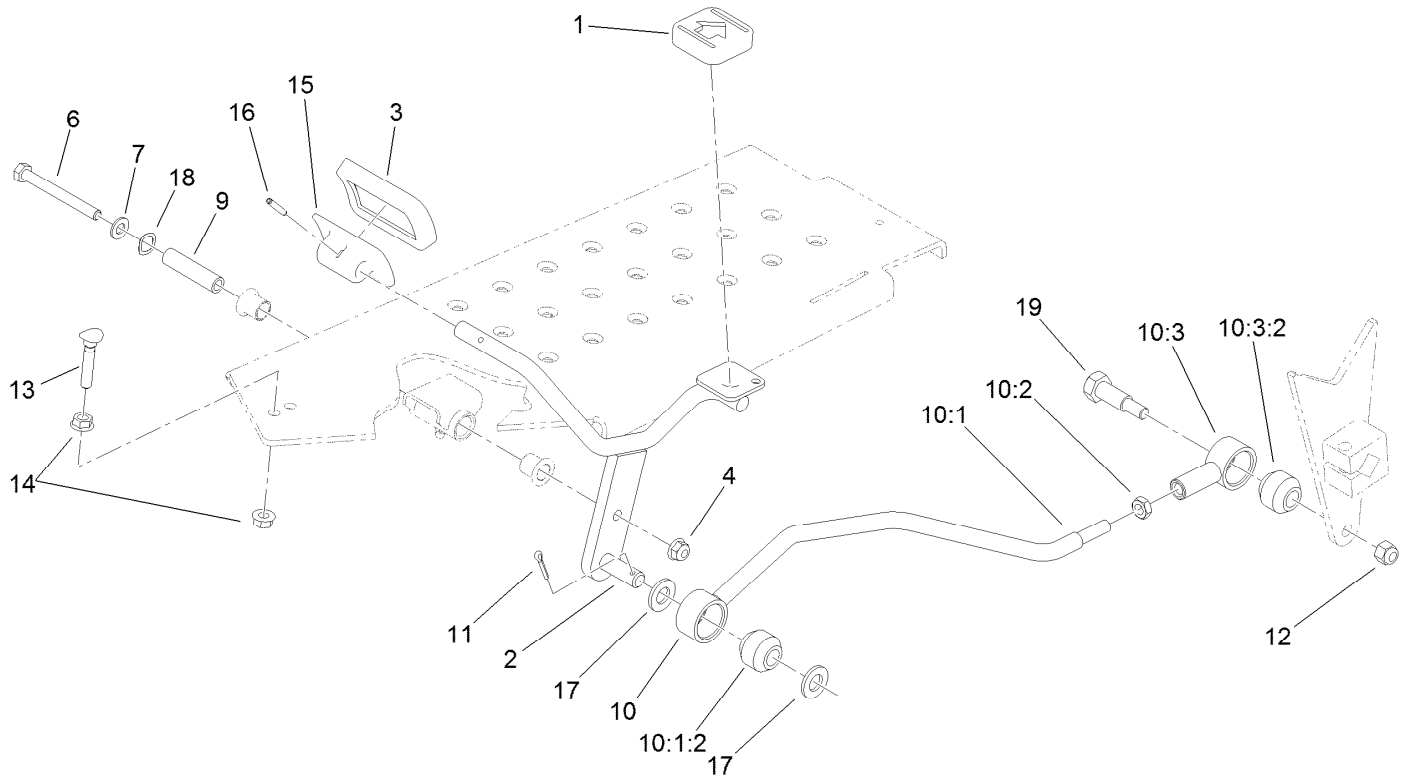

## Traction Pedal Assembly

Ref.	Part Number	Qty.	Description	Ref.	Part Number	Qty.	Description
1	74-9110	1	Pad-Pedal, Reverse	10:3	115-5623	1	Isolated Rod End ASM
2	108-5498-01	1	Pedal	10:3:2	23-2270	1	Bushing-Rubber
3	74-9100	1	Pad-Pedal, Forward	11	3272-10	1	Pin-Cotter
4	104-8300	1	Nut-Flange, NI	12	3296-39	1	Nut-Lock, NI
6	322-14	1	Screw-HH	13	17-9420	1	Screw-Handle
7	3256-23	1	Washer-Flat	14	32128-20	2	Nut-HF
9	85-8960	1	Spacer	15	117-9507	1	Pedal-Accelerator
10		1	Traction Rod ASM ●	16	32121-45	1	Pin-Spring
10:1	115-5626	1	Rod ASM	17	106-9888	2	Washer-Flat
10:1:2	23-2270	1	Bushing-Rubber	18	108473	1	Washer-Wave
10:2	3220-3	1	Nut-HJ	19	117-4698	1	Screw-Shoulder, HH

● Not serviced separately

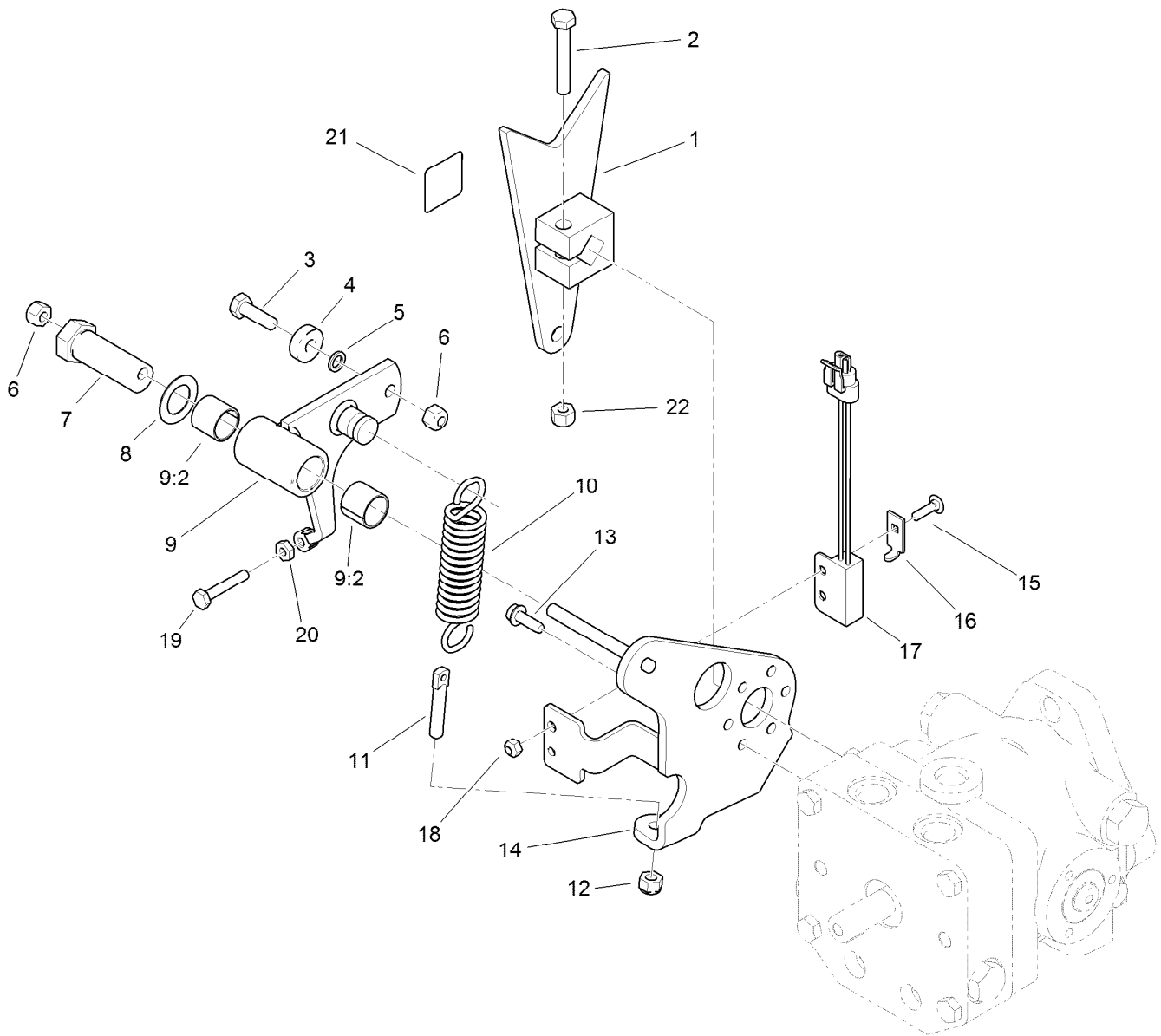

## Pump Control Lever Assembly

<i>Ref.</i>	<i>Part Number</i>	<i>Qty.</i>	<i>Description</i>	<i>Ref.</i>	<i>Part Number</i>	<i>Qty.</i>	<i>Description</i>
1	112-6458-03	1	Lever-Pump	12	3296-4	1	Nut-Lock
2	323-11	1	Screw-HH	13	49-2040	3	Screw-HWHTF
3	322-5	1	Screw-HH	14	108-5490-03	1	Plate-Pump
4	251-307	1	Bearing-Ball	15	3229-20	1	Screw-CARR
5	75-5470	1	Spacer-Bearing	16	100-4872	1	Plate-Switch, Neutral
6	3296-29	2	Nut-Lock, NI	17	105-0023	1	Switch-Proximity
7	76-8640	1	Stud-Traction	18	3296-2	1	Nut-Lock, NI
8	3-6498	1	Washer-Thrust	19	321-43	1	Capscrew
9	119-7196	1	Arm ASM	20	3218-1	1	Nut-Jam
9:2	94-9609	2	Bushing-Straight	21	93-9051	1	Decal-Bolt, Eccentric
10	85-9030	1	Spring-Extension	22	3296-39	1	Nut-Lock, NI
11	18-6380	1	Pin-Adjustment, Steering				

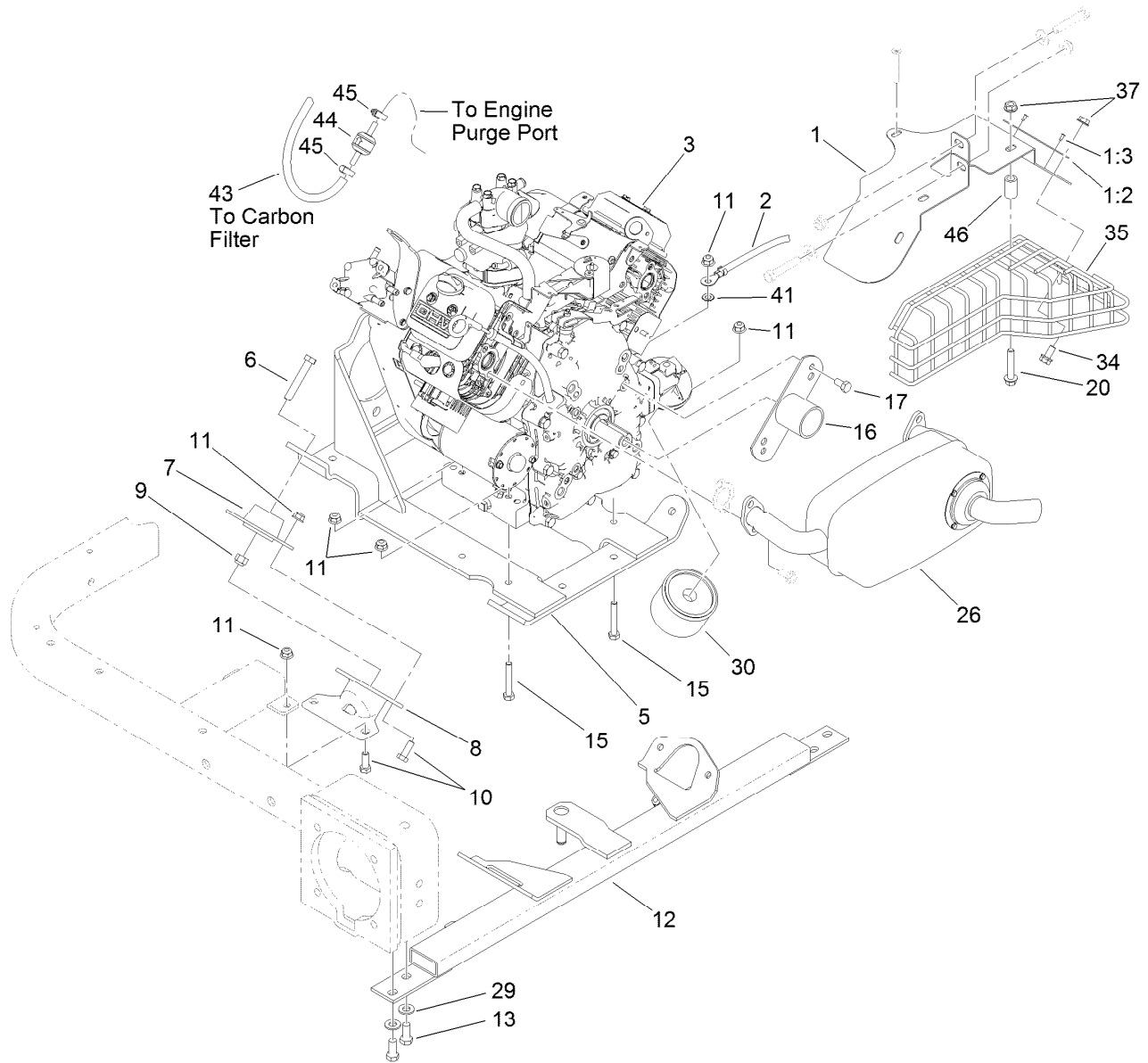

## Engine Installation Assembly

Ref.	Part Number	Qty.	Description	Ref.	Part Number	Qty.	Description
1	119-7191	1	Muffler Shield ASM	15	322-10	4	Screw-HH
1:2	95-0645	1	Plate-Surface, Hot	16	95-0632-03	1	Cover
1:3	3269-32	2	Rivet-Pop	17	3210-2	2	Screw-HH
2	54-3093	1	Cable-Battery, Negative	20	94-5780	2	Screw-HWH
3	120-3402	1	Engine-Briggs & Stratton, 305447-0285-G2 ●	26	120-3476	1	Muffler-Dual Inlet
5	108-2809-03	1	Support-Engine	29	3256-24	4	Washer-Flat
6	323-11	4	Screw-HH	30	107-7817	1	Filter-Oil, Engine
7	121-9076	4	Mount-Engine	34	3234-14	2	Screw-HHF
8	125-1954	2	Mount-Front	35	110-6348-03	1	Shield-Exhaust
9	104-8301	4	Nut-Flange, NI	37	32128-25	4	Nut-HF
10	322-4	12	Screw-HH	41	3255-8	1	Washer-Lock
11	104-8300	16	Nut-Flange, NI	43	117-9569	1	Hose-Fuel
12	120-3461-01	1	Mount-Engine	44	115-7868	1	Valve-Check, Vacuum
13	323-5	4	Screw-HH	45	2412-108	2	Clamp-Worm
				46	59-2580	2	Spacer-Tubular

● Obtain parts from [www.briggsandstratton.com](http://www.briggsandstratton.com)



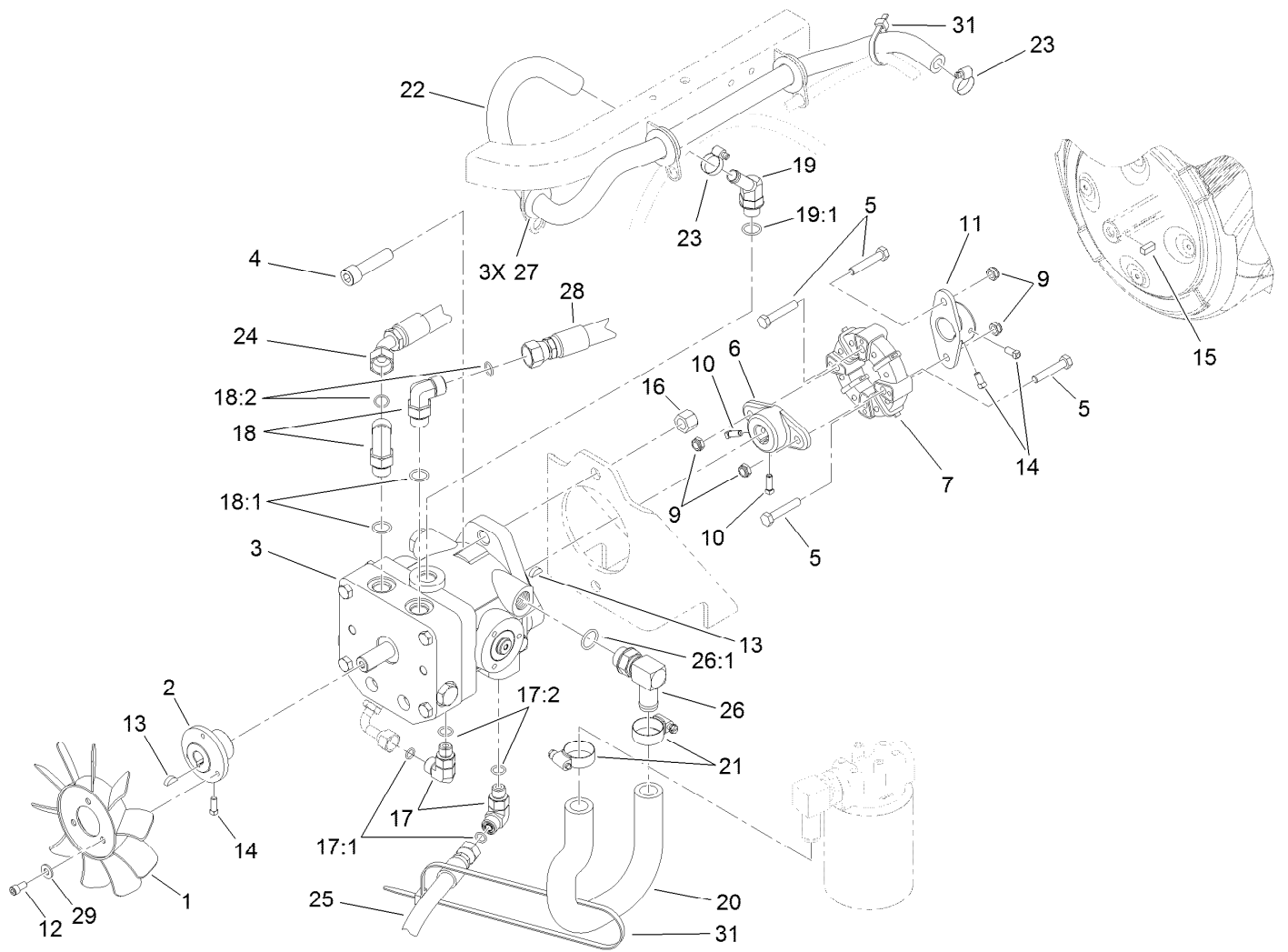

## Pump and Coupling Assembly

Ref.	Part Number	Qty.	Description	Ref.	Part Number	Qty.	Description
1	1-633869	1	Fan-Pump, Cooling	18	340-98	2	Fitting-HYD, 90 DEG
2	108-5484	1	Hub-Fan	18:1	237-79	1	O-Ring
3	114-0612	1	Variable Piston Pump ASM	18:2	237-30	1	O-Ring
4	3274-5	2	Screw-HSH	19	354-126	1	Fitting-HYD, 45 DEG
5	322-9	4	Screw-HH	19:1	237-79	1	O-Ring
6	110-9695	1	Hub-Pump	20	108-5481	1	Hose-Suction
7	119-0652	1	Coupler-Rubber	21	2412-129	2	Clamp-Hose
9	3296-47	4	Nut-Lock, NI	22	110-1325	1	Hose-Return
10	3241-6	2	Screw-SQH	23	2412-36	2	Clamp-Hose
11	110-5236	1	Hub-Engine	24	108-8440	1	Hose ASM
12	3274-52	3	Screw-HSH	25	108-8428	1	HYD Hose ASM
13	3257-32	2	Key-Woodruff	26	87-8170	1	Fitting
14	3241-7	4	Screw-SQH	26:1	237-80	1	O-Ring
15	85-9020	1	Key-Square	27	240-4	3	Grommet-Rubber
16	3296-23	2	Nut-Lock, NI	28	110-1322	1	HYD Hose ASM
17	340-77	2	Fitting-HYD, 90 DEG	29	3256-22	3	Washer-Flat
17:1	237-22	1	O-Ring	31	3290-379	2	Tie-Cable
17:2	237-42	1	O-Ring				

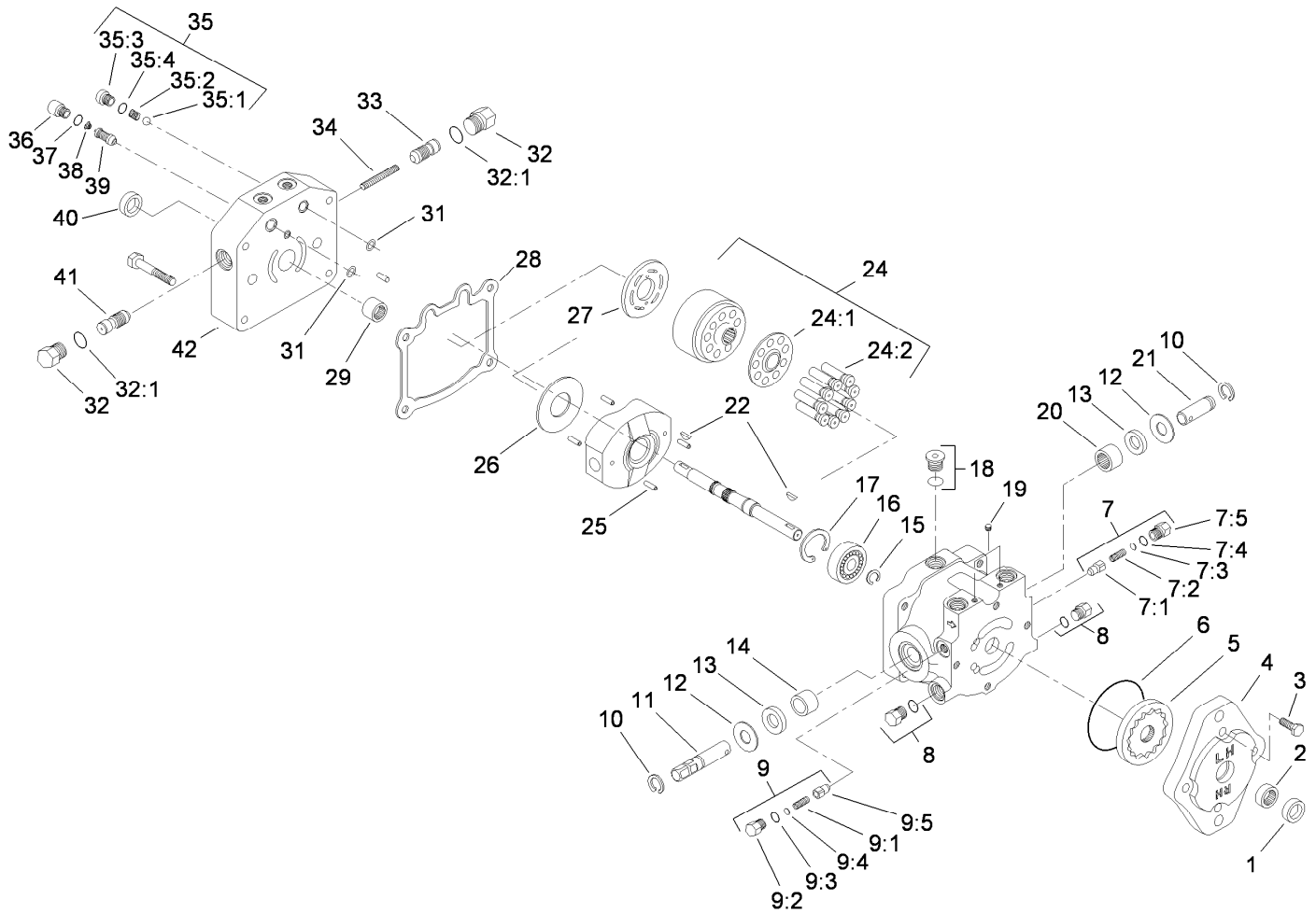

## Variable Piston Pump Assembly No. 114-0612

Ref.	Part Number	Qty.	Description	Ref.	Part Number	Qty.	Description
1	93-4133	1	Seal-Lip	9:5	83-7260	1	Cone-Relief, Charge
2	67-8050	1	Bearing-Needle	10	32151-46	2	Ring-Retaining
3	322-4	4	Screw-HH	11	88-8180	1	Shaft-Trunnion
4	114-0611	1	Housing-Pump, Charge	12	25-2510	2	Washer-Flat
5	95-5812	1	Gerotor ASM	13	25-3210	2	Seal-Lip
6	237-95	1	O-Ring	14	88-8190	1	Bearing-Journal
7	49-8520	1	Implement Relief Kit	15	32151-83	1	Ring-Snap
7:1	83-7260	1	Cone-Relief, Charge	16	95-5809	1	Bearing-Ball
7:2	25-2570	1	Spring-Valve	17	32151-75	1	Ring-Retaining
7:3	25-2470	1	Pack-Shim	18	67-9090	1	Plug ASM
7:4	237-86	1	O-Ring	19	75-0160	1	Plug-Pipe
7:5	25-2460	1	Plug-HH	20	252-82	1	Bearing-Needle
8	67-8030	2	Plug ASM	21	25-2500	1	Shaft-Trunnion
9	49-8510	1	Valve Kit	22	3257-32	2	Key-Woodruff
9:1	25-2480	1	Spring-Valve	24	48-1800	1	Cylinder Block Kit
9:2	25-2460	1	Plug-HH	24:1		1	Retainer-Slipper ●
9:3	237-86	1	O-Ring	24:2		9	Piston ASM ●
9:4	25-2470	1	Pack-Shim	25	32121-91	4	Pin-Spring

● Not serviced separately

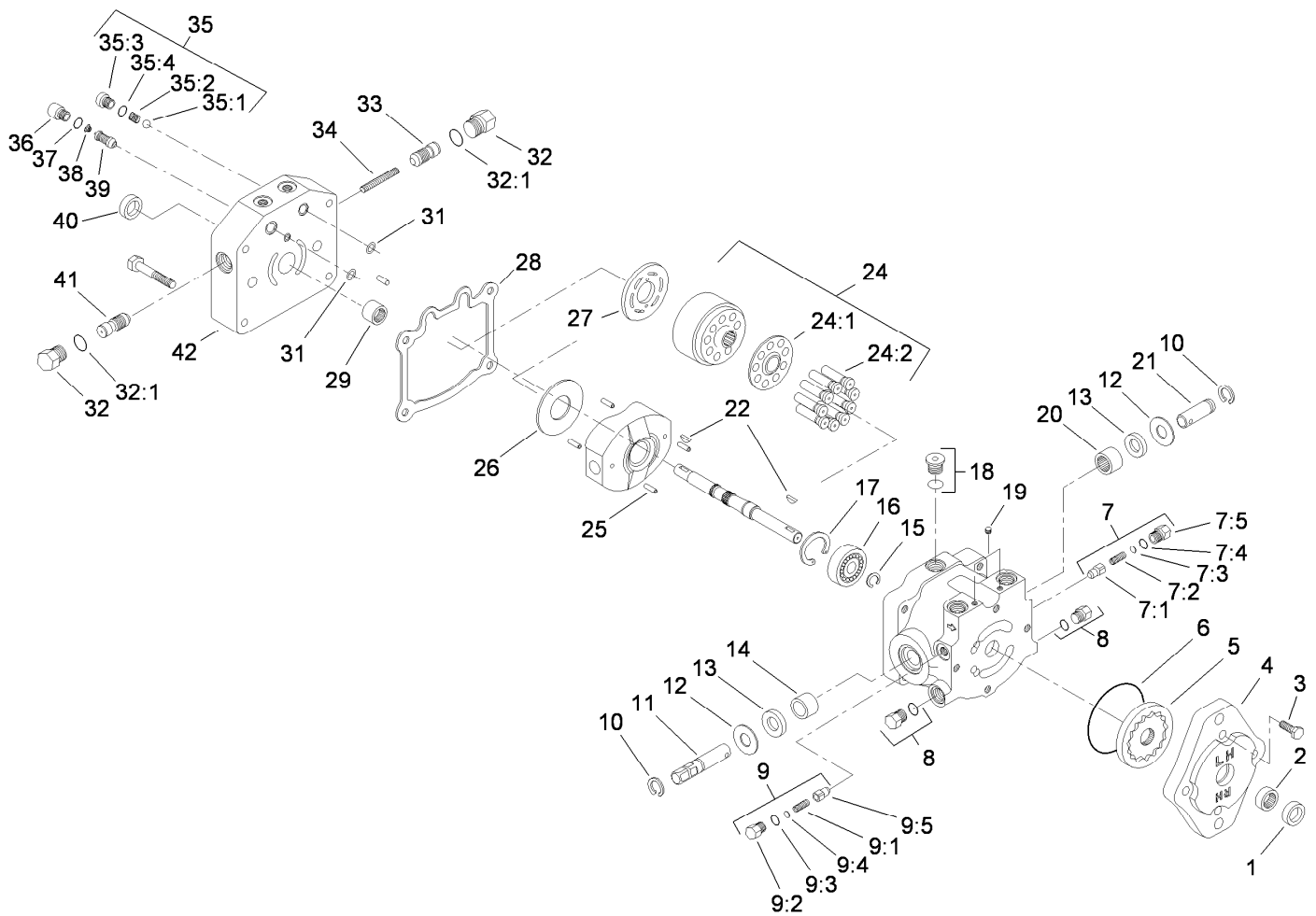

## Variable Piston Pump Assembly No. 114-0612 (continued)

Ref.	Part Number	Qty.	Description	Ref.	Part Number	Qty.	Description
26	25-2380	1	Plate-Thrust	35:2	25-2640	1	Spring-Valve
27	88-8160	1	Plate-Valve	35:3	25-2650	1	Plug-Valve, Check
28	25-2400	1	Gasket	35:4	237-86	1	O-Ring
29	110-6341	1	Bearing-Roller	36	75-0190	1	Plug-Special
31	112-7652	2	O-Ring	37	75-0240	1	O-Ring
32	28-3440	1	Plug-Threaded	38	110-6342	1	Spring
32:1	75-0240	1	O-Ring	39	110-6343	1	Valve-Scr
33	98-0920	1	Valve-Acceleration	40	88-8230	1	Seal-Lip
34	25-2610	1	Spring-Valve	41	98-0920	1	Valve-Acceleration
35	99-5689	1	Check Valve Kit	42	112-7651	1	Cap-End
35:1	25-2490	1	Ball				

● Not serviced separately

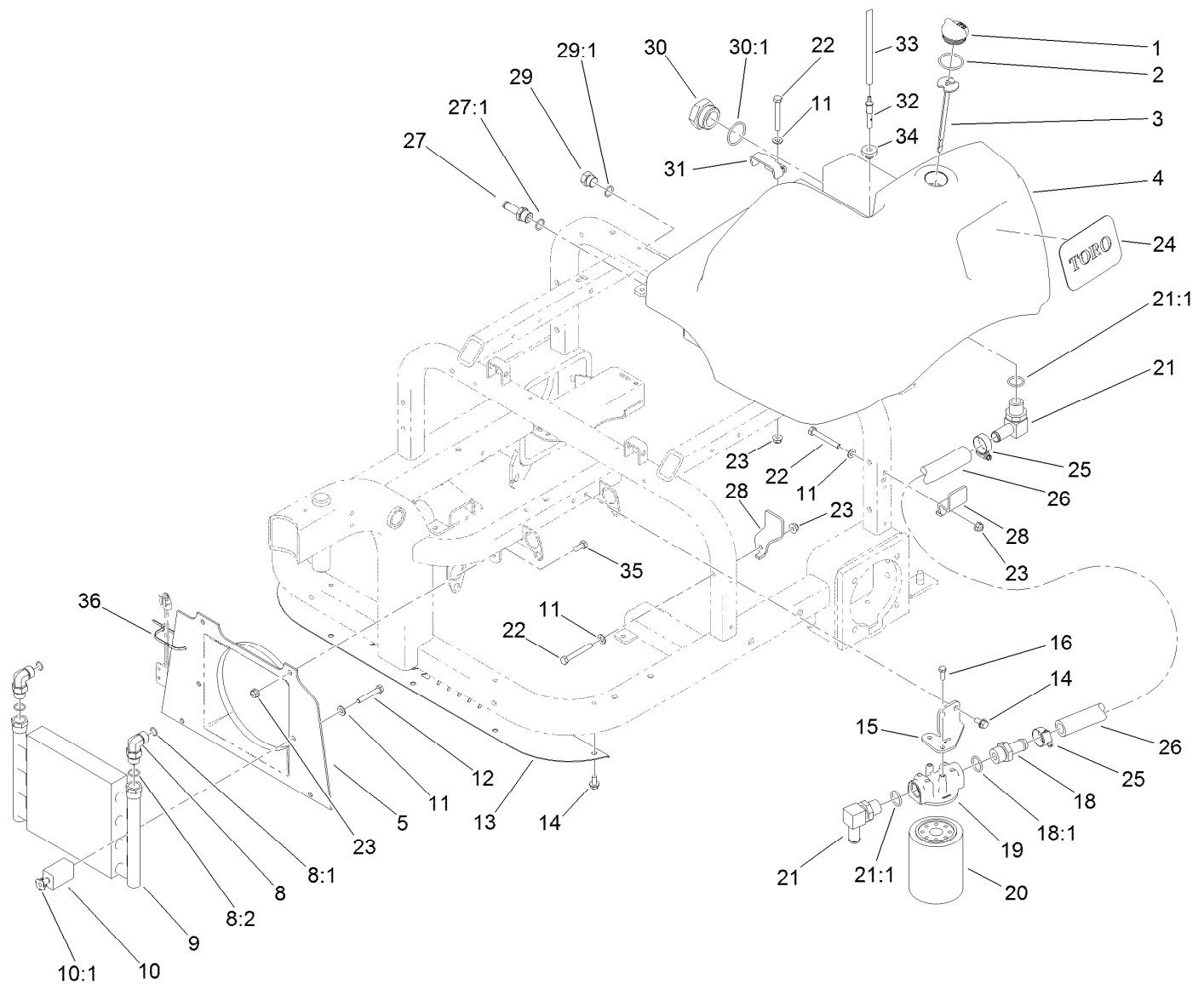

## Hydraulic Tank, Filter and Cooler Assembly

Ref.	Part Number	Qty.	Description	Ref.	Part Number	Qty.	Description
1	93-7498	1	Plug-Plastic	21	353-987	2	Fitting-HYD, 90 DEG (Barbed)
2	237-101	1	O-Ring	21:1	237-81	1	O-Ring
3	108-7996	1	Dipstick ASM	22	322-12	5	Screw-HH
4	119-9040	1	Tank-Hydraulic	23	104-8300	9	Nut-Flange, NI
5	108-5477	1	Shroud-Fan	24	108-8452	1	Decal-Logo
8	340-98	2	Fitting-HYD, 90 DEG	25	2412-129	2	Clamp-Hose
8:1	237-79	1	O-Ring	26	108-5483	1	Hose-Suction, Tank
8:2	237-30	1	O-Ring	27	354-121	1	Fitting-Straight
9	108-8457	1	Cooler-Oil	27:1	237-79	1	O-Ring
10	85-9550	2	Rubber Clamp ASM	28	108-7965	2	Clamp-Tank, HYD
10:1	85-9670	1	T-Nut	29	353-550	1	Plug-HYD, HH
11	3256-23	7	Washer-Flat	29:1	237-79	1	O-Ring
12	322-11	2	Screw-HH	30	108-8468	1	Plug-HH
13	121-2474-03	1	Panel-Cooler	30:1	237-101	1	O-Ring
14	32144-14	7	Screw-HWHTF	31	108-7903	1	Clamp-Tank
15	108-5482	1	Bracket-Filter, Oil	32	110-1372	1	Fitting-Vent, Tank
16	3234-4	2	Screw-HHF	33	110-8181	1	Hose-Fuel
18	354-73	1	Fitting-Straight	34	46-6560	1	Bushing
18:1	237-81	1	O-Ring	35	322-3	4	Screw-HH
19	68-8990	1	Filter Head ASM	36	3290-379	1	Tie-Cable
20	54-0110	1	Filter-Oil, Transmission				

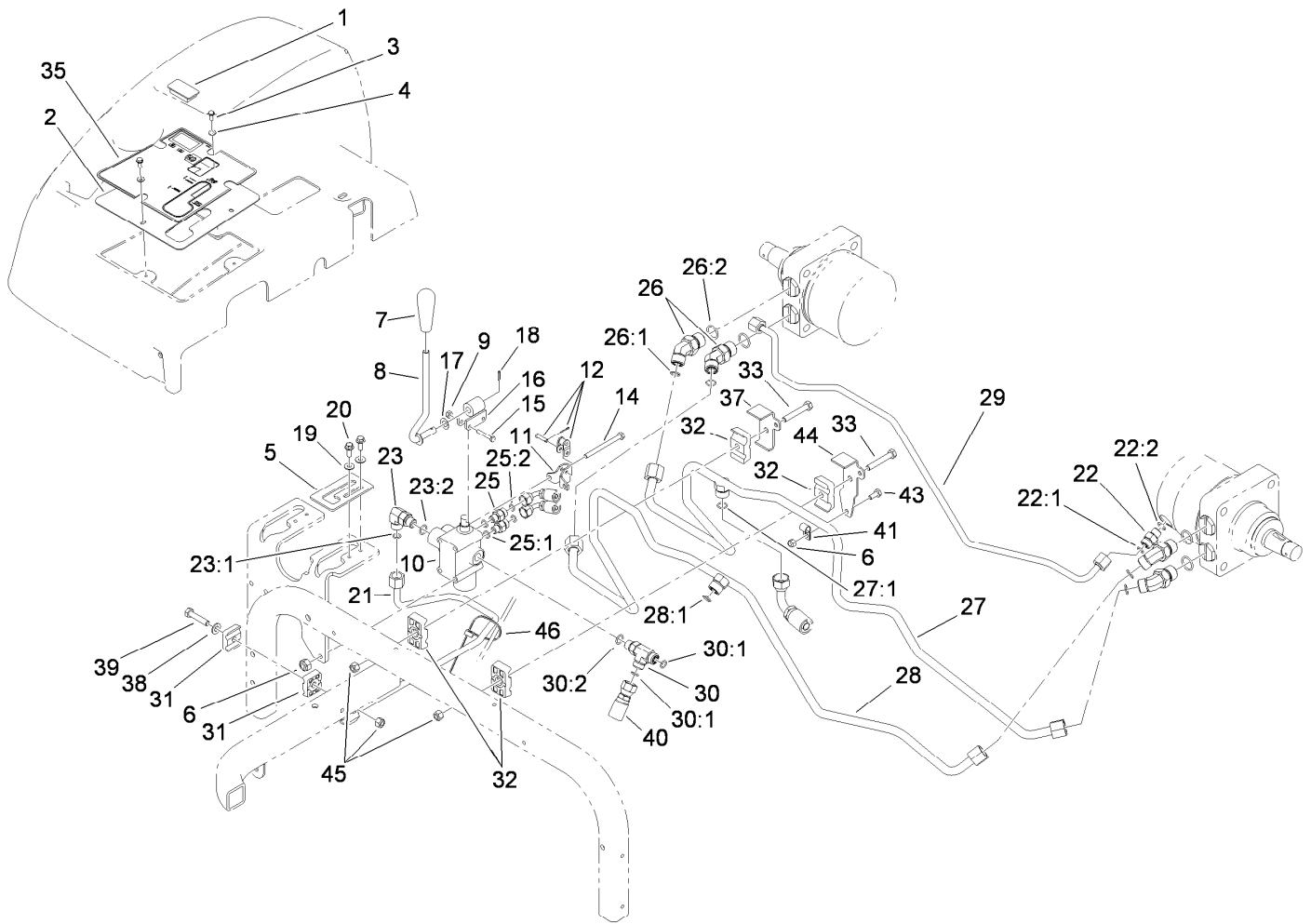

## Lift Valve and Rear Tube Assembly

<i>Ref.</i>	<i>Part Number</i>	<i>Qty.</i>	<i>Description</i>	<i>Ref.</i>	<i>Part Number</i>	<i>Qty.</i>	<i>Description</i>
1	99-7420	1	Plug-Hole	22:1	237-22	1	O-Ring
2	108-7909-03	1	Panel-Control	22:2	237-42	1	O-Ring
3	3290-321	4	Screw-HWH	23	340-77	1	Fitting-HYD, 90 DEG
4	3256-51	4	Washer-Flat	23:1	237-22	1	O-Ring
5	108-7941	1	Plate-Guide, Lever	23:2	237-42	1	O-Ring
6	3296-42	4	Nut-Lock, NI	25	340-92	2	Fitting-HYD, Straight
7	98-0152	1	Knob-Tapered	25:1	237-78	1	O-Ring
8	108-7942	1	Rear Lever ASM	25:2	237-21	1	O-Ring
9	3296-2	2	Nut-Lock, NI	26	340-89	4	Fitting-HYD, 45 DEG
10	121-9070	1	Valve ASM	26:1	237-30	1	O-Ring
11	88-8480	1	Bracket-Pivot	26:2	237-80	1	O-Ring
12	2710-20	1	Link-Offset	27	108-8406	1	Tube ASM
14	321-23	3	Screw-HH	27:1	237-30	1	O-Ring
15	3290-360	2	Screw-HH	28	110-1323	1	Tube ASM
16	98-8159	1	Pivot	28:1	237-30	1	O-Ring
17	3290-477	1	Washer-Curved	29	110-1330	1	Tube ASM
18	32121-73	1	Pin-Roll	30	340-86	1	Fitting-Tee
19	3256-1	2	Washer-Flat	30:1	237-22	2	O-Ring
20	3234-33	2	Screw-HHF	30:2	237-42	1	O-Ring
21	108-8416	1	Tube ASM	31	56-7973	2	Clamp-Tube
22	340-2	1	Fitting-HYD, Straight	32	56-7976	4	Clamp-Tube

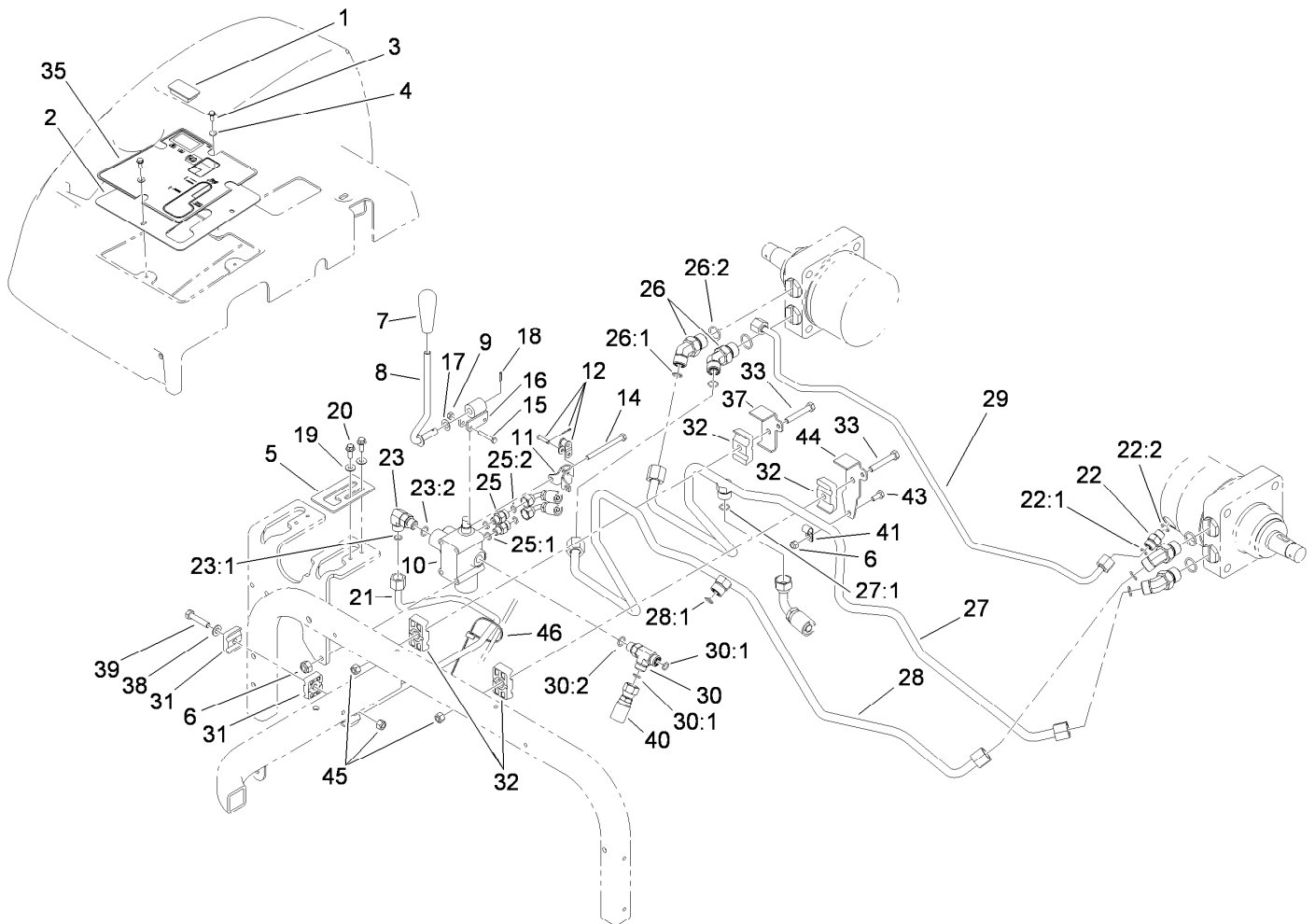

## Lift Valve and Rear Tube Assembly (continued)

<i>Ref.</i>	<i>Part Number</i>	<i>Qty.</i>	<i>Description</i>	<i>Ref.</i>	<i>Part Number</i>	<i>Qty.</i>	<i>Description</i>
33	322-10	2	Screw-HH	41	2412-89	1	Clamp-R
35	108-8484	1	Decal-Lift, Rear	43	321-3	1	Screw-HH
37	110-1333	1	Bracket-Clamp	44	110-1332	1	Bracket-Clamp
38	3256-23	1	Washer-Flat	45	3296-29	3	Nut-Lock, NI
39	322-7	1	Screw-HH	46	3290-378	1	Tie-Cable
40	108-8426	1	Hose ASM				

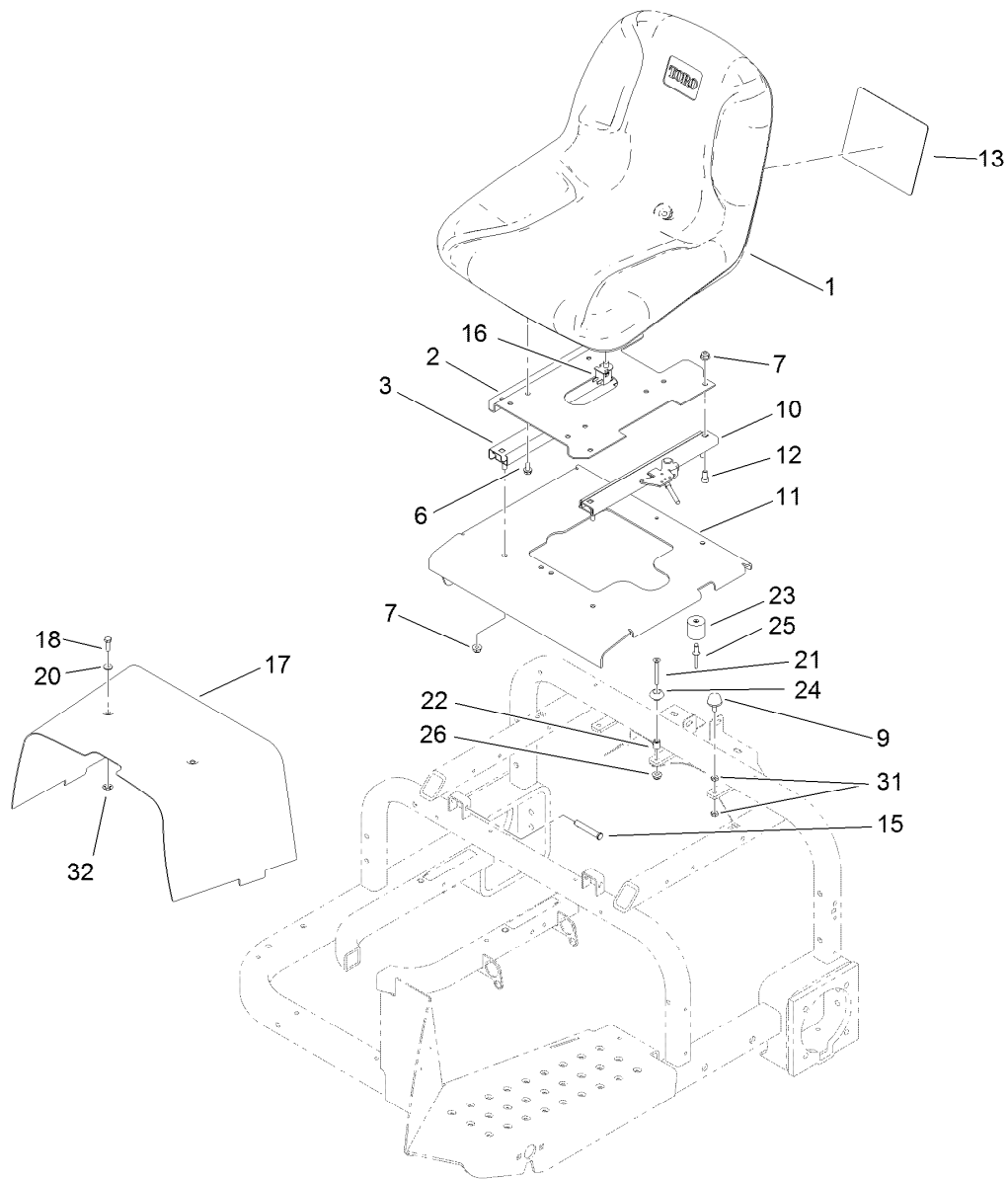

## Seat and Shroud Assembly

<i>Ref.</i>	<i>Part Number</i>	<i>Qty.</i>	<i>Description</i>	<i>Ref.</i>	<i>Part Number</i>	<i>Qty.</i>	<i>Description</i>
1	108-6878	1	Seat	17	108-6859-01	1	Shroud-Center
2	108-7931-03	1	Base-Seat	18	321-5	2	Screw-HH
3	51-0780	1	Slider-Seat	20	3256-1	2	Washer-Flat
6	3234-14	4	Screw-HHF	21	363-1571	1	Screw-PFH
7	104-8300	8	Nut-Flange, NI	22	609588	1	Spacer
9	1-523420	2	Bumper	23	99-7830	1	Rubber Receptical ASM
10	51-0790	1	Adjuster-Seat, LH	24	99-7833	1	Post-Holding
11	112-1445-03	1	Seat	25	3290-412	1	Rivet
12	3274-12	4	Screw-HSH	26	104-7201	1	Nut-HF
13	108-8418	1	Decal-Service	31	3218-1	4	Nut-Jam
15	112-7153	2	Pin	32	106-8737	2	Nut-Retainer
16	82-2190	1	Switch-Bail				

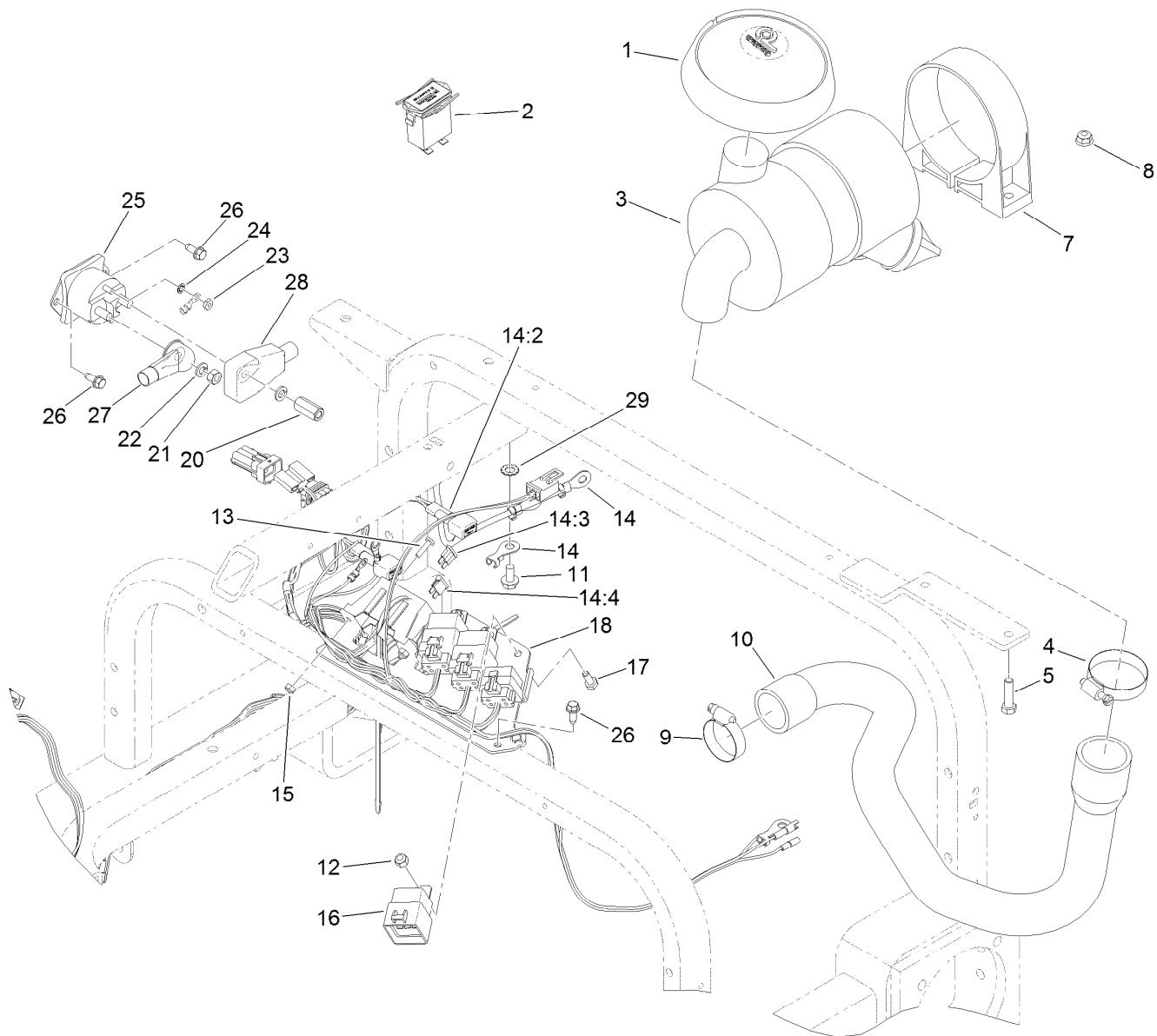

## Wire Harness, Air Cleaner and Hose Assembly

<i>Ref.</i>	<i>Part Number</i>	<i>Qty.</i>	<i>Description</i>	<i>Ref.</i>	<i>Part Number</i>	<i>Qty.</i>	<i>Description</i>
1	120-4848	1	Hood-Inlet, Air	14:4	109355	1	Fuse-Blade, 15 Amp
2	1-513374	1	Meter-Hour	15	3296-2	2	Nut-Lock, NI
3	93-2190	1	Air Cleaner ASM	16	99-7430	3	Relay
4	2412-92	1	Clamp-Hose	17	321-3	3	Screw-HH
5	322-6	2	Screw-HH	18	112-1444-01	1	Bracket-Relay
7	95-5806	1	Bracket-Mounting	20	110-3380	1	Nut-Standoff
8	104-8300	2	Nut-Flange, NI	21	3218-13	1	Nut-Jam, Brass
9	2412-3	1	Clamp-Hose	22	3253-4	2	Washer-Lock
10	117-9576	1	Hose-Air	23	3219-14	2	Nut-Hex
11	32144-14	1	Screw-HWHTF	24	3254-1	2	Washer-Lock, Int
12	3296-42	3	Nut-Lock, NI	25	28-4210	1	Solenoid
13	3250-13	2	Screw-PPH	26	32144-10	4	Screw-HWH
14	112-1446	1	Harness-Wire	27	110-3315	1	Cable-Positive, Starter
14:2	100-4918	2	Diode-Over Molded	28	110-3314	1	Cable-Positive, Battery
14:3	218-578	1	Fuse-Blade, 10 Amp	29	3255-9	1	Washer-Lock





## Air Cleaner Assembly No. 93-2190

<i>Ref.</i>	<i>Part Number</i>	<i>Qty.</i>	<i>Description</i>
2	108-3811	1	Filter-Air
3	94-3652	1	Cover ASM
3:1	1-643283	2	Latch-Cleaner, Air
4	87-9400	1	Valve-Vacuator
5	285-17	1	Plug-Pipe

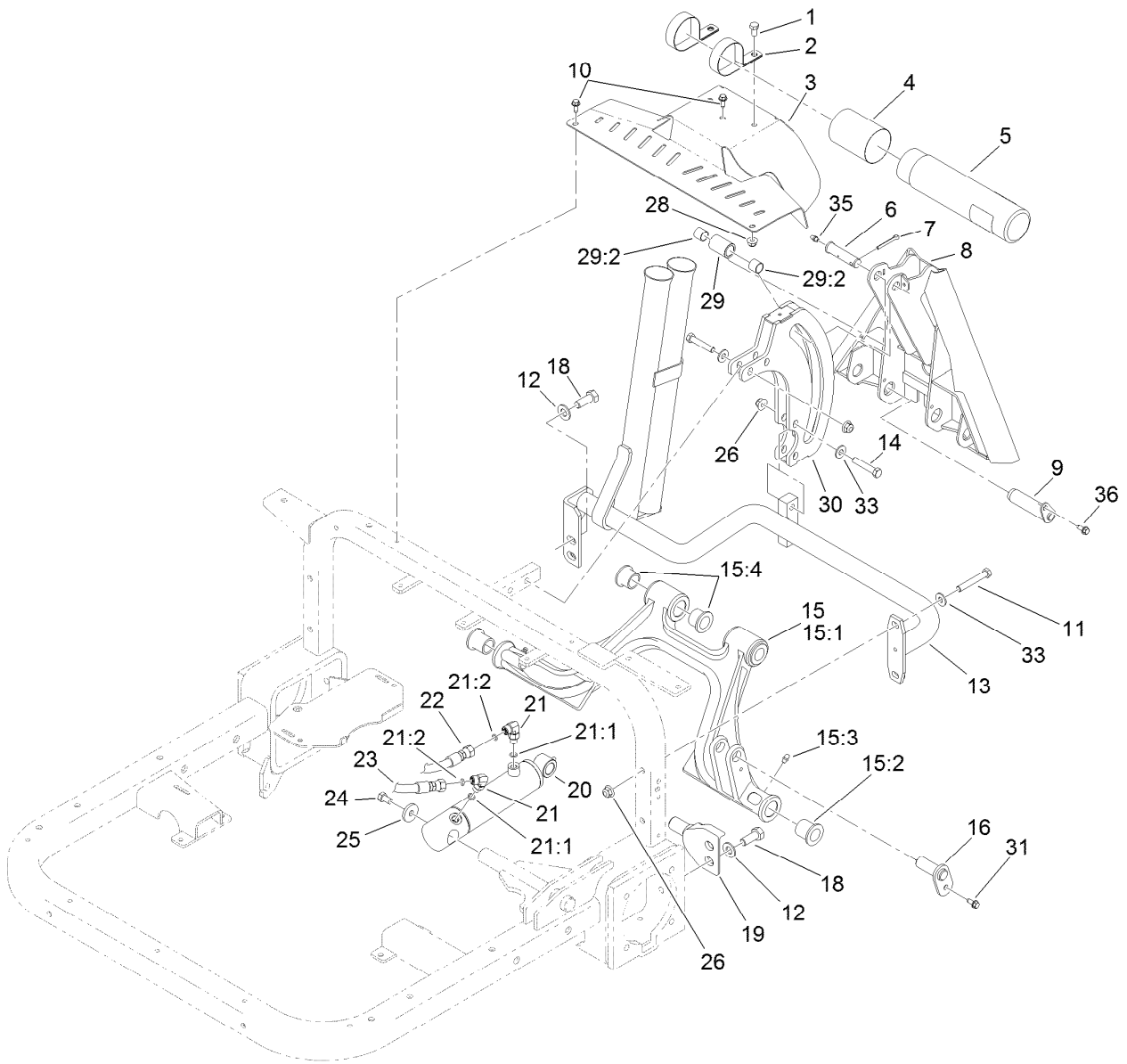

## Rear Hitch Assembly

Ref.	Part Number	Qty.	Description	Ref.	Part Number	Qty.	Description
1	322-2	2	Screw-HH	18	325-5	4	Screw-HH
2	2412-133	2	R-Clamp	19	115-5618	2	Pivot-Hub
3	121-9081-01	1	Cover-Rear	20	115-5647	1	HYD Lift Cylinder ASM
4	104-7048	1	Cap-Housing	21	340-132	2	Fitting-HYD, 90 DEG
5	104-7050	1	Tube-Manual	21:1	237-78	1	O-Ring
6	108-2282	1	Pin-Clevis	21:2	237-21	1	O-Ring
7	3272-23	1	Pin-Cotter	22	95-8837	1	Hose ASM
8	108-6870-01	1	Adapter ASM	23	100-3833	1	Hose-HYD
9	108-6885	2	Pin ASM	24	323-34	1	Screw-HH
10	32144-10	3	Screw-HWH	25	53-6380	1	Washer-Flat
11	323-12	2	Screw-HH	26	104-8301	6	Nut-Flange, NI
12	3256-26	4	Washer-Flat	28	104-8300	2	Nut-Flange, NI
13	120-3465-03	1	Frame-Hitch	29	108-5472	1	Tube ASM
14	323-10	4	Screw-HH	29:2	256-311	2	Bushing-Split
15	120-3457	1	Rear Hitch ASM	30	110-1368-01	1	Plate-Roller
15:1	115-5609-01	1	Hitch	31	32144-10	1	Screw-HWH
15:2	95-3577	2	Bushing	33	3256-3	6	Washer-Flat
15:3	302-5	4	Fitting-Grease	35	302-5	1	Fitting-Grease
15:4	33-3090	4	Bushing	36	99-8445	2	Screw-HWH
16	115-5648	1	Pin-Flag				

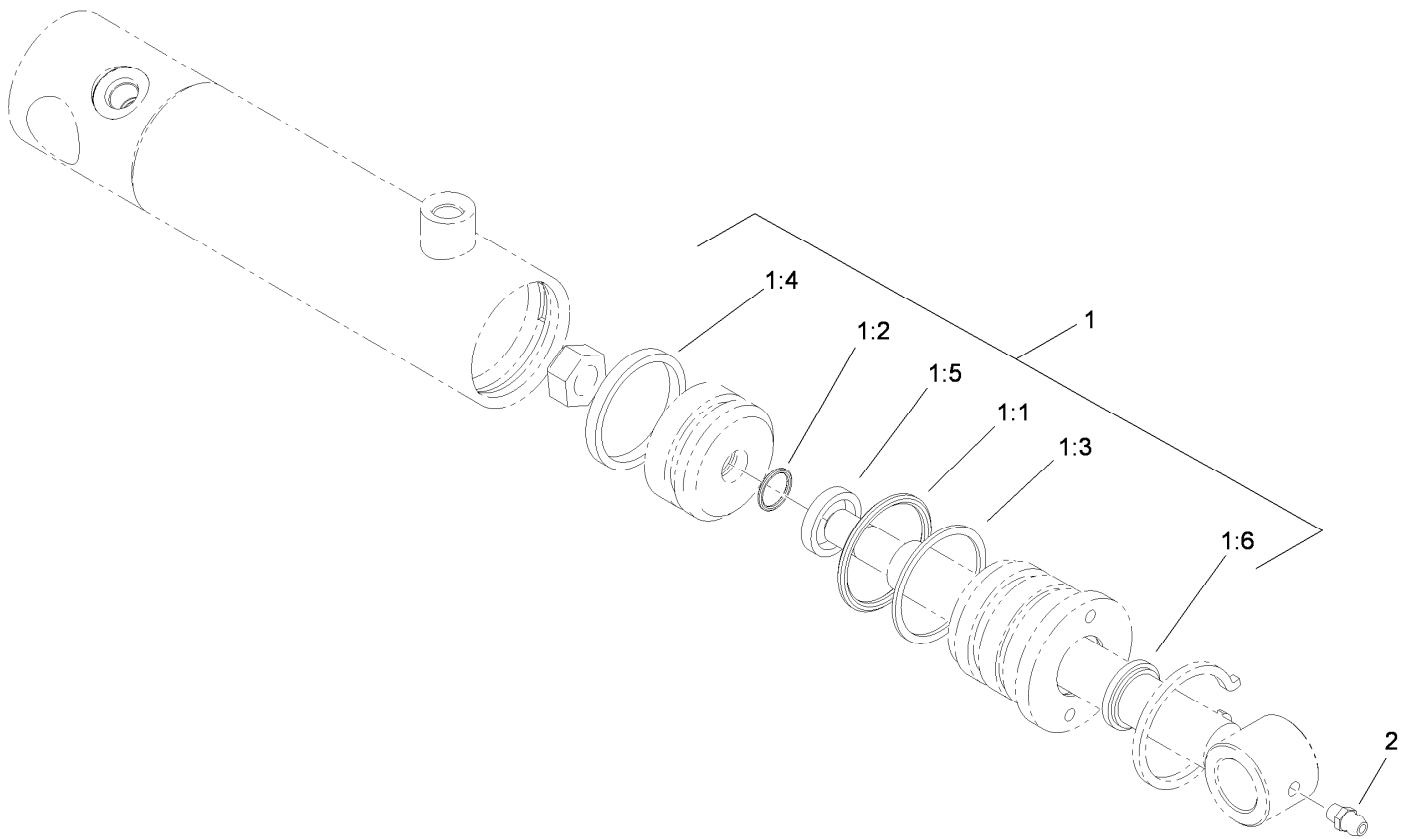

## Hydraulic Lift Cylinder Assembly No. 115-5647

<i>Ref.</i>	<i>Part Number</i>	<i>Qty.</i>	<i>Description</i>
1	108-4597	1	Seal Kit
1:1		1	O-Ring ●
1:2		1	O-Ring ●
1:3		1	Ring-Back Up ●
1:4		1	Seal-Psp ●
1:5		1	Seal-Rod ●
1:6		1	Seal-Dust ●
2	302-5	1	Fitting-Grease

● Not serviced separately

# Attachments and Accessories

## For 08703 Sand Pro 3040 Traction Unit

<b>Product Name</b>	<b>Model/Part</b>
Midmount Toolbar System .....	08731
Tooth Rake .....	08751
Spring Rake .....	08752
Rear Broom .....	08753
Finish Grader .....	08754
Manual Blade .....	08714
Spiker .....	08755
Drag Mat Carrier System .....	08756
Debris Blower .....	08759
Rear Remote Hydraulic Kit .....	08781
Wheel and Tire Assembly .....	121-9077
Spark Arrestor Screen .....	119-7185
MVP Filter Kit .....	30035
Yellow Hydraulic Cap .....	107-1576
Draw Bar Hitch Assembly .....	110-1375
Light Kit .....	110-1314
Speed Limiter Kit .....	110-1371
Smooth Wheel and Tire ASM .....	112-0034
Drag Mat Assembly .....	112-1424
Variable Orifice Kit .....	112-1433
QAS Nail Drag .....	08761
QAS Bunker Pump .....	08765
Premium All Purpose Grease (Tube) .....	108-1190
Carbide Tine Pack .....	119-2152
Premium All Season Hydraulic Fluid (55 Gallon Drum) .....	108-1177
Synthetic Turf Conditioner, Sand Pro/Infield Pro with QAS .....	08790
Premium All Season Hydraulic Fluid (5 Gallon Pail) .....	108-1178
Turf Groomer, Sand Pro Traction Unit with QAS .....	08794
Yellow Hydraulic Fluid Cap (Tethered) .....	107-2174
Premium Engine Oil SAE 30 (Drum) .....	108-1196
Premium Engine Oil SAE 30 (Pail) .....	108-1197

**Notes:**

**Notes:**

**Notes:**



**Count on it.**