



Count on it.

Parts Catalog

30in Stand-On Aerator

Model No. 23518—Serial No. 314000001 and Up

Model No. 33518—Serial No. 314000001 and Up



Ordering Replacement Parts

To order replacement parts, please supply the part number, the quantity, and the description of each part desired.

Understanding Reference Numbers

Each identified part in an illustration has a reference number. The reference number for a part also appears in the parts list, along with other information about the part.

This catalog uses two special reference number formats, one to indicate parts in a service assembly and another to indicate the quantity of a given part in an illustration.

Service Assembly Reference Numbers

Parts in service assemblies have reference numbers in the form a:b. The a represents the reference number of the entire service assembly and the b represents a sequential number unique to each part within the service assembly.

For example, a wheel assembly might be identified by reference number 6, the tire by 6:1, the valve by 6:2, and the wheel by 6:3. When you order the assembly identified by reference number 6, you receive all parts identified by reference numbers 6:1, 6:2, and 6:3. However, you may also order any part individually. Reference numbers of this type appear in illustration and in parts lists.

Reference Numbers Indicating Quantity

In an illustration, if a reference number indicates more than one part, the reference number has the form nX y. The n represents the quantity of the part, the X is the multiplication symbol, and the y represents the reference number.

For example, in an illustration, the reference number 2X 37 means that two of the parts identified by reference number 37 are indicated.

List of Abbreviations

AR: as required

ASM: assembly

BBC: blade brake control

BHTF: button head thread forming

CARR: carriage

CCW: counter clockwise

CW: clockwise

DEG: degrees

DPA: Dual Point Adjustment

ECM: electronic control module

EXT: external

FH: flat head

GA: gauge

HD: heavy-duty

HF: hex flange

HH: hex head

HHF: hex head flange

HHFTF: hex head flange thread forming

HJ: hex jam

HLH: hex lag head

HOC: height-of-cut

HSBH: hex socket button head

HSFH: hex socket flat head

HSH: hex socket head

HWH: hex washer head

HWHTF: hex washer head thread forming

HYD: hydraulic

LH: left hand

LP: Liquefied Petroleum Gas

LPG: Liquefied Petroleum Gas

NI: nylon insert

NPTF: national pipe thread fine

PFH: phillips flat head

PPH: phillips pan head

PPHTF: phillips pan head thread forming

PRH: phillips round head

PTH: phillips truss head

PTO: power-take-off

RH: right hand

ROPS: roll-over protection system

RRB: rear roller brush

SFH: slotted fillister head

SHH: slotted hex head

SHWH: slotted hex washer head

SPH: slotted pan head

SQH: square head

SRH: slotted round head

STD: standard

TAP: self tapping

TTH: torx truss head

Contents

Main Frame Assembly	4
Main Frame Decal Assembly No. 116-8138	6
Caster Wheel and Fork Assembly	8
Platform Assembly No. 116-9135	10
Tower Assembly	12
Ground Drive Assembly	14
Idler Arm Assembly No. 116-9307	16
RH Transaxle Assembly No. 116-9712	18
LH Transaxle Assembly No. 116-9713	20
Axle and Bearing Assembly No. 116-9545	22
Tine Assembly	24
RH Tine Wheel Assembly No. 116-6738	26
LH Tine Wheel Assembly No. 116-6739	28
Fuel Assembly	30
Motion Control Assembly	32
Electrical Assembly	34
Auxiliary Hydraulic Assembly	36
Manifold W/Check and Relief Valve Assembly No. 116-9549	38
Hydraulic Cylinder Assembly No. 116-6969	40
Hydraulic Pump Assembly No. 116-9129	42
Engine Assembly	44

Main Frame Assembly

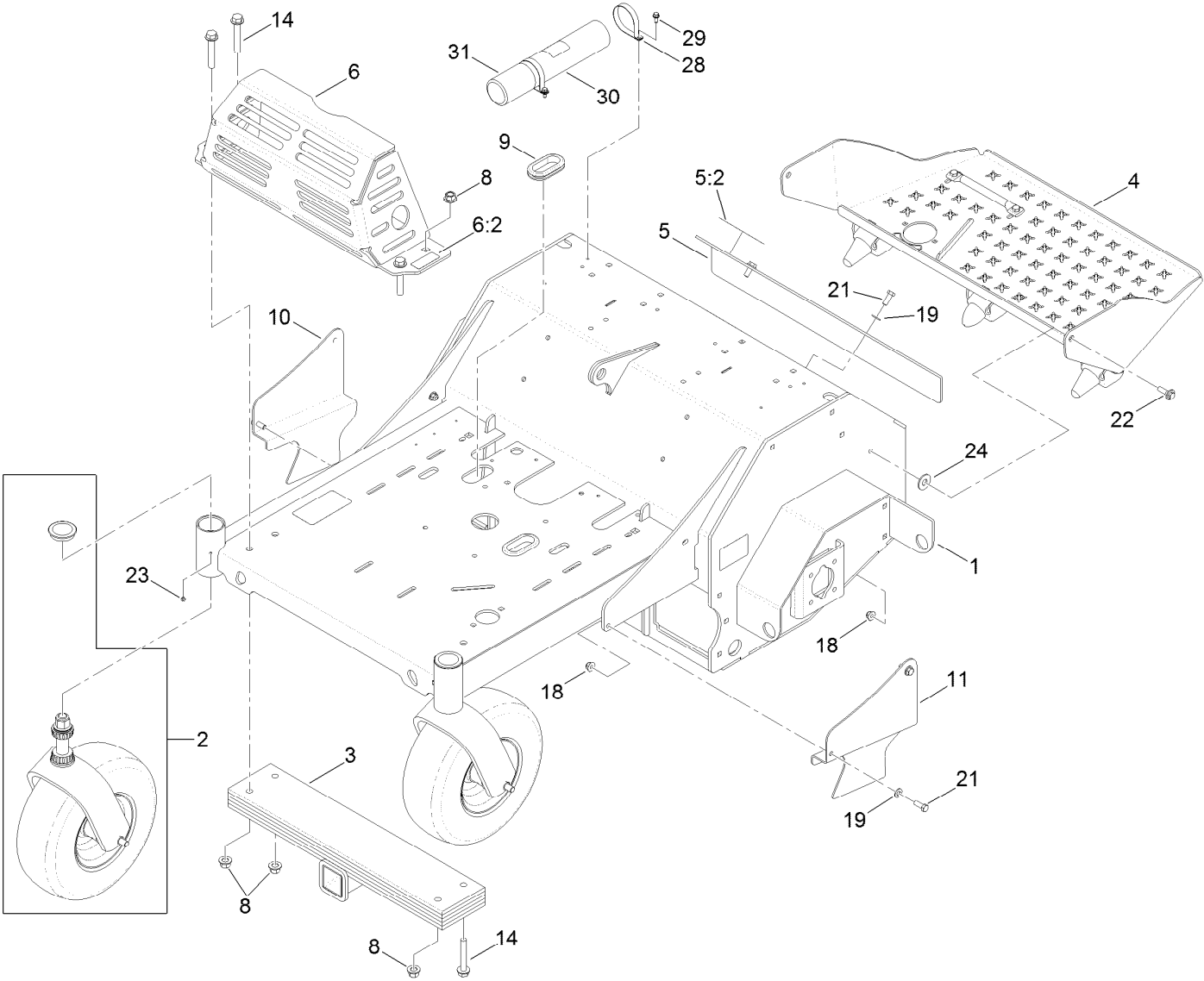

Main Frame Assembly (continued)

<i>Ref.</i>	<i>Part Number</i>	<i>Qty.</i>	<i>Description</i>	<i>Ref.</i>	<i>Part Number</i>	<i>Qty.</i>	<i>Description</i>
1	116-8138	1	Main Frame ASM	11	116-6611-01	1	Guard-Chain, LH
2		2	Front Caster ASM W/Fork ●	14	3234-40	4	Screw-HF
3	116-6536-01	1	Weight	18	104-8301	6	Nut-Flange, NI
4	116-9135	1	Platform ASM W/Rocker	19	3256-24	6	Washer-Flat
5	116-7300	1	Access Cover ASM	21	323-6	6	Screw-HH
5:2	121-6163	1	Decal-Tine Ground Operation (Ce)	22	614672	2	Bolt-Shoulder
6	116-8258	1	Muffler Guard ASM	23	1-811010	2	Plug
6:2	115-2047	2	Decal-Surface, Hot	24	3256-6	2	Washer-Flat
8	99-5107	4	Nut-Lock	28	107-1865	2	R-Clamp
9	126-0015	2	Grommet	29	32144-10	2	Screw-HWH
10	116-6612-01	1	Guard-Chain, RH	30	104-7050	1	Tube-Manual
				31	104-7048	1	Cap-Housing

● Not serviced separately

Main Frame Decal Assembly No. 116-8138

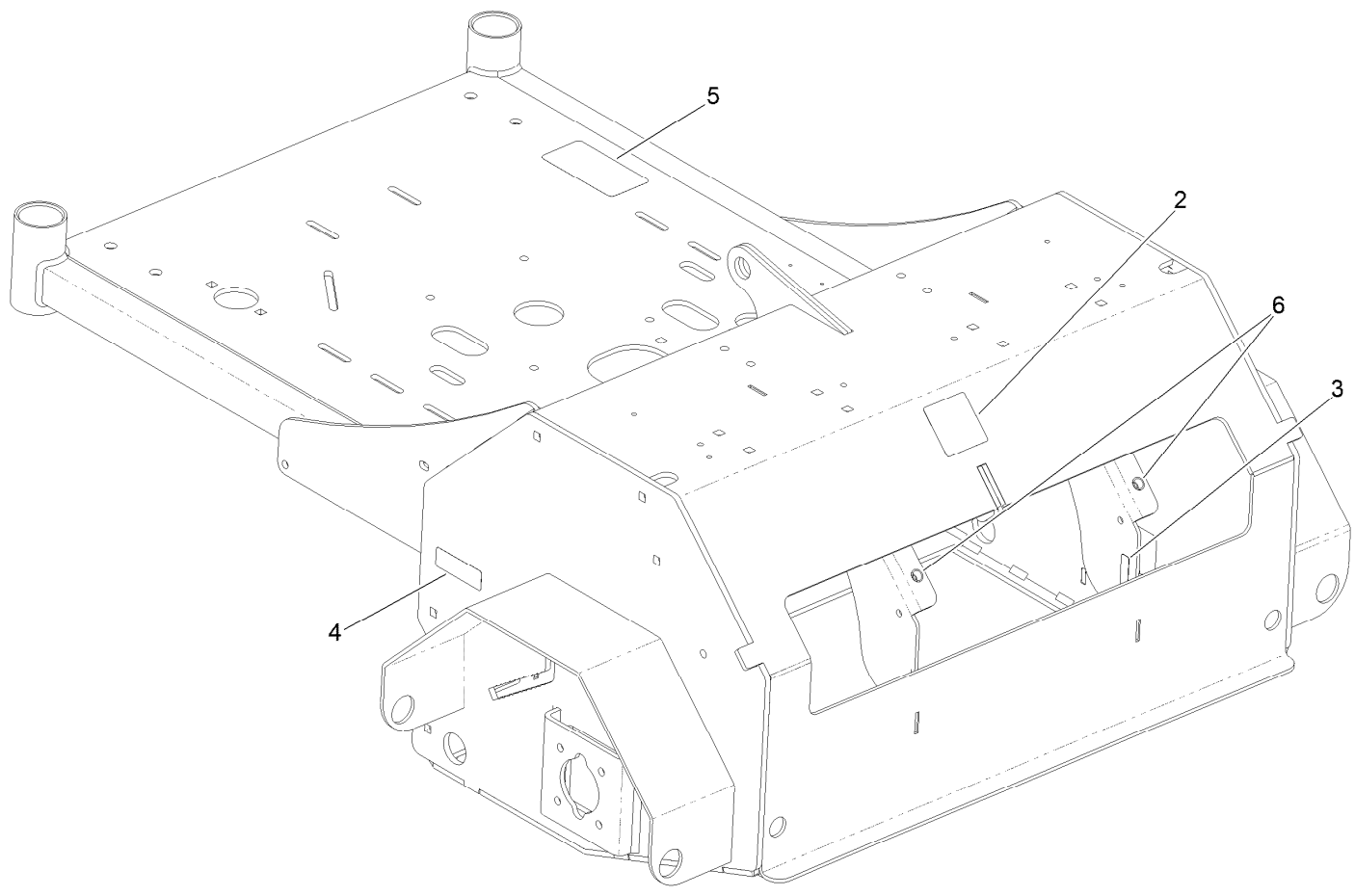

Main Frame Decal Assembly No. 116-8138 (continued)

<i>Ref.</i>	<i>Part Number</i>	<i>Qty.</i>	<i>Description</i>	<i>Ref.</i>	<i>Part Number</i>	<i>Qty.</i>	<i>Description</i>
2	121-6150	1	Decal-Warning	5	116-9391	1	Decal-Belt Routing
3	120-9570	1	Decal-Warning	6	32148-10	2	Insert-Nut
4	121-6161	2	Decal-Danger				

Caster Wheel and Fork Assembly

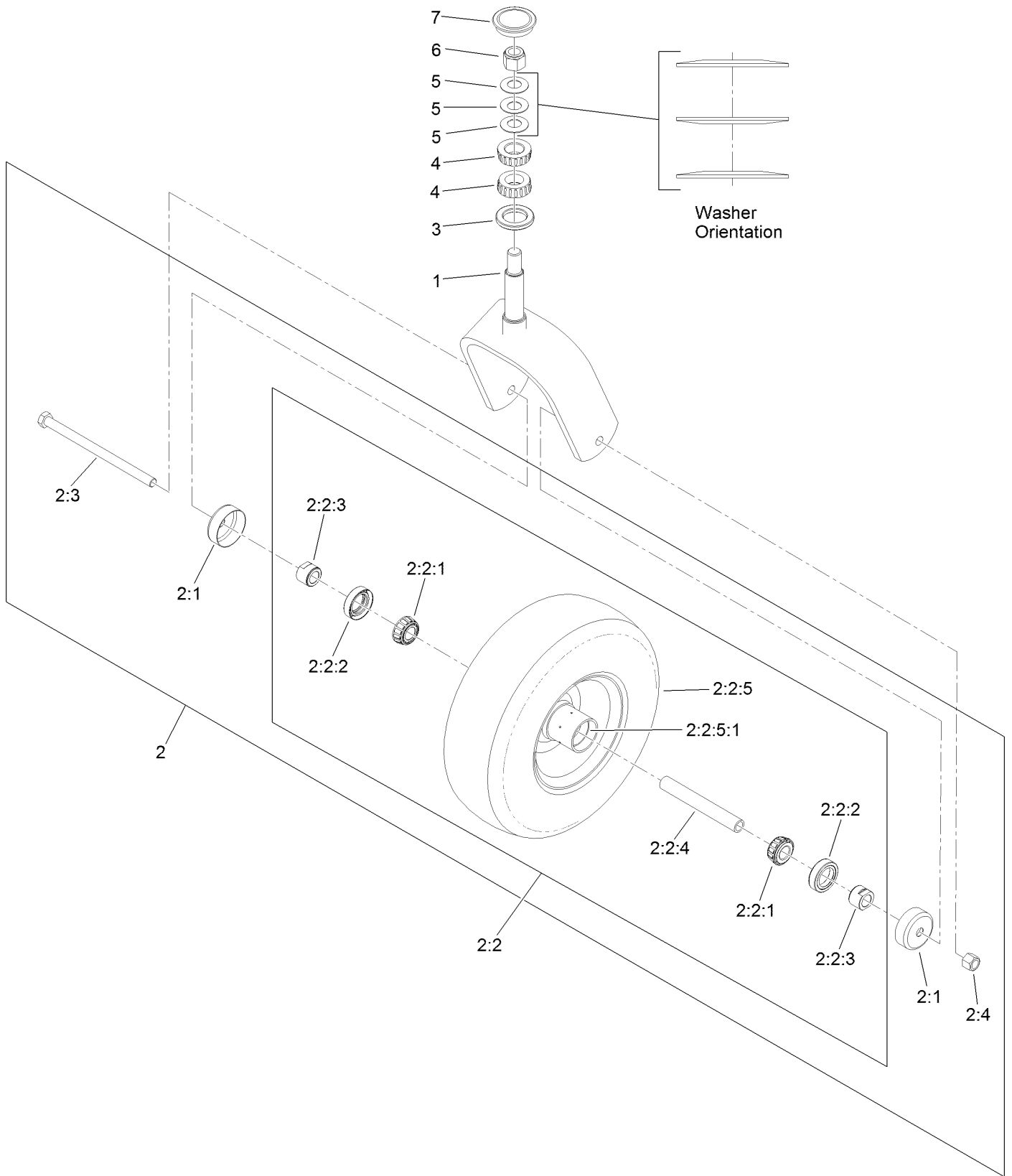

Caster Wheel and Fork Assembly (continued)

<i>Ref.</i>	<i>Part Number</i>	<i>Qty.</i>	<i>Description</i>	<i>Ref.</i>	<i>Part Number</i>	<i>Qty.</i>	<i>Description</i>
1	116-6704-01	1	Caster	2:2:5:1	1-633584	1	Bearing-Cup
2	109-9126	1	Wheel And Tire ASM	2:3	325-42	1	Screw-HH
2:1	103-2768	2	Guard-Seal	2:4	3296-23	1	Nut-Lock, NI
2:2		1	Wheel And Tire ASM ●	3	116-5647	1	Seal-Grease
2:2:1	1-633585	2	Bearing-Cone, Taper	4	1-543509	2	Bearing-Roller, Tapered
2:2:2	103-0063	2	Seal-Caster	5	1-633508	3	Washer-Bellville
2:2:3	103-3051	2	Spacer-Nut ■	6	3296-51	1	Nut-Lock, NI
2:2:4	103-3155	1	Axle-Caster	7	103-4882	1	Cap-Grease
2:2:5		1	Wheel And Tire ASM ●				

● Not serviced separately

■ Use Pro-Lock, Nut Type (P/N 1-840022, .5ml tube) on threads.

Platform Assembly No. 116-9135

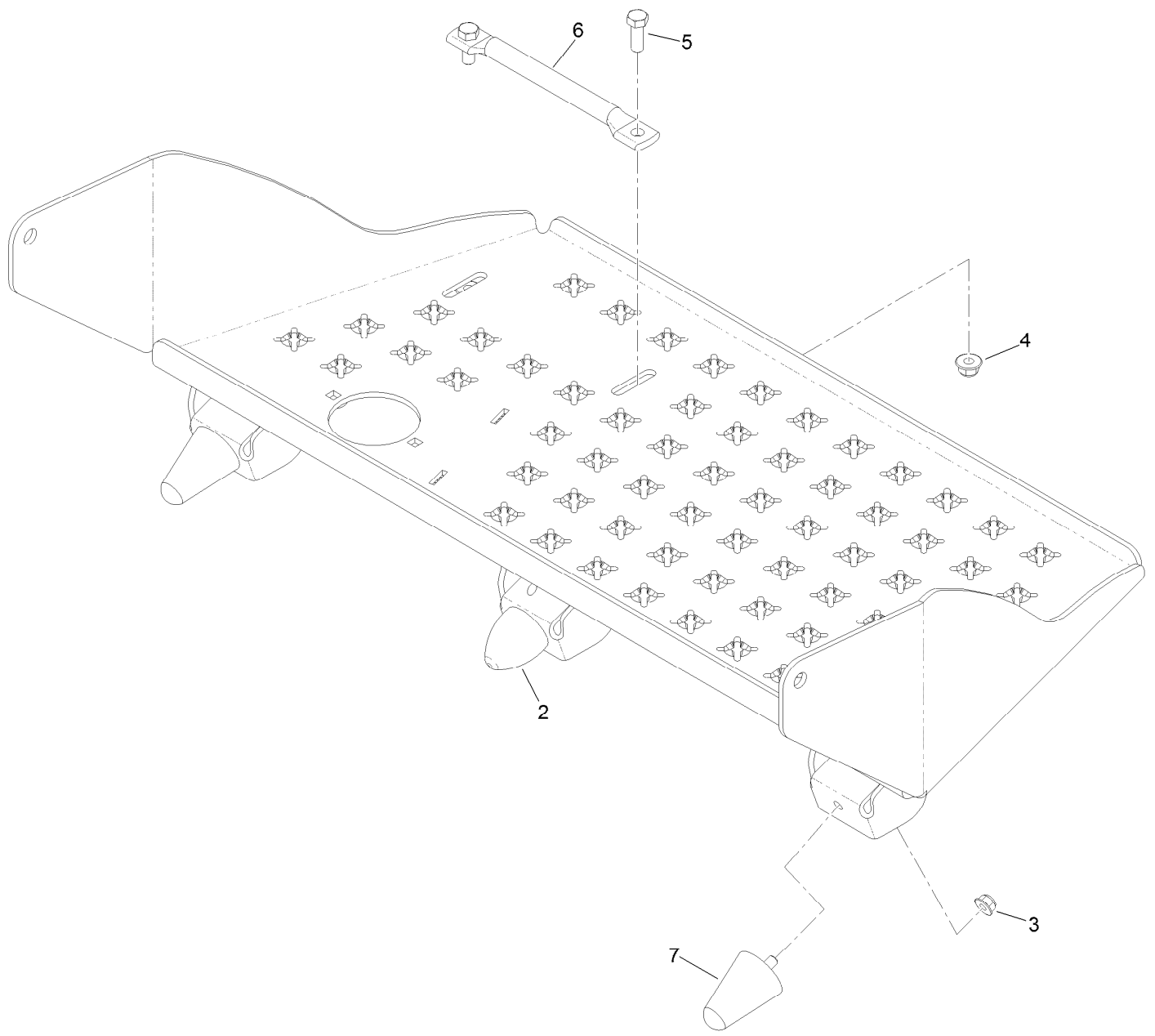

Platform Assembly No. 116-9135 (continued)

<i>Ref.</i>	<i>Part Number</i>	<i>Qty.</i>	<i>Description</i>
2	114-1926	1	Bumper-Rubber
3	104-8300	3	Nut-Flange, NI
4	104-8301	2	Nut-Flange, NI

<i>Ref.</i>	<i>Part Number</i>	<i>Qty.</i>	<i>Description</i>
5	323-6	2	Screw-HH
6	116-8950-01	1	Rocker-Pedal, Foot
7	114-1925	2	Bumper-Rubber

Tower Assembly

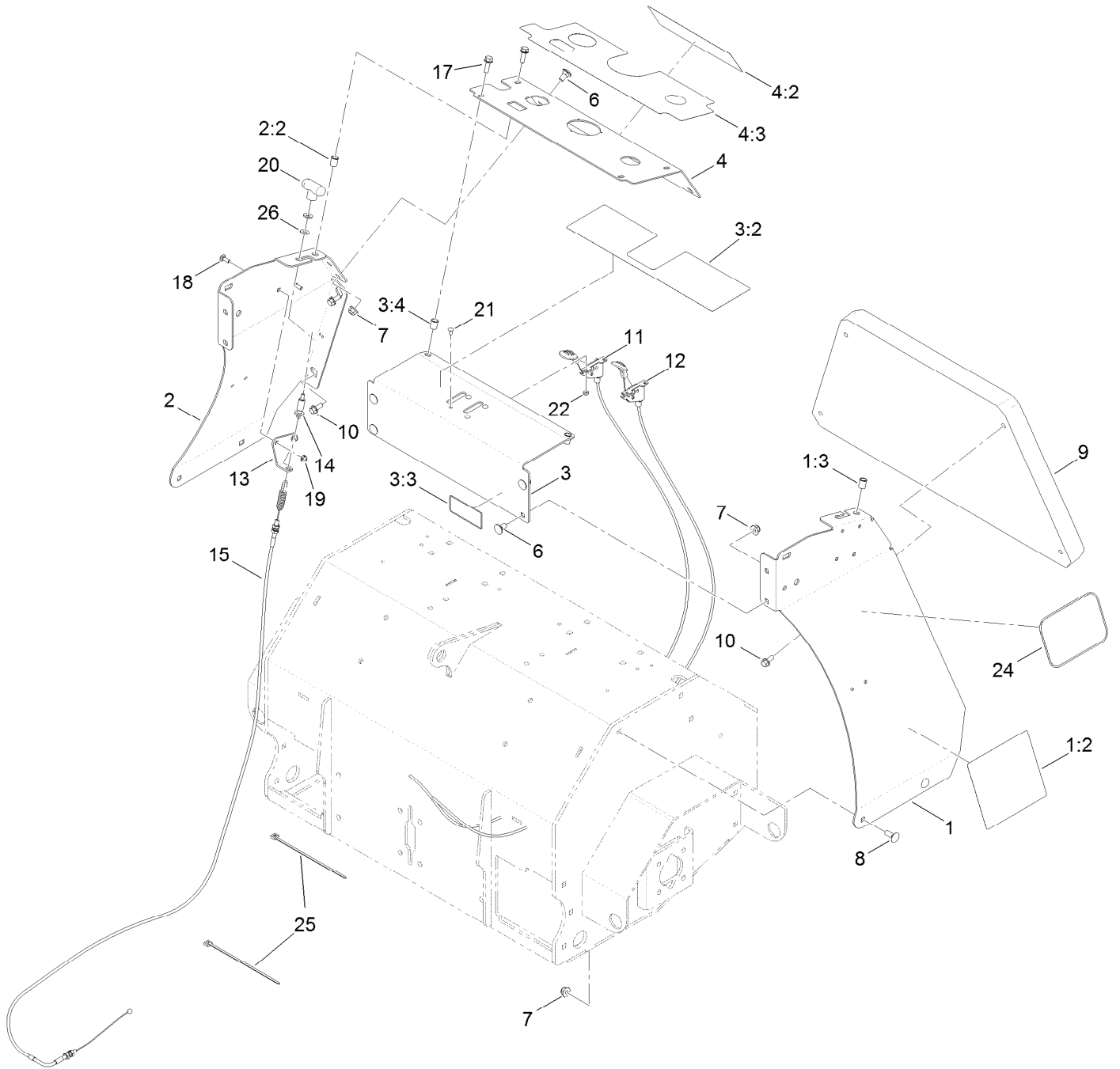

Tower Assembly (continued)

<i>Ref.</i>	<i>Part Number</i>	<i>Qty.</i>	<i>Description</i>	<i>Ref.</i>	<i>Part Number</i>	<i>Qty.</i>	<i>Description</i>
1	116-9387	1	LH Side Panel ASM	9	116-6959	1	Cushion-Black
1:2	116-9392	1	Decal-Service Aid Ce	10	3234-5	4	Screw-HHF
1:3	32148-7	1	Nut-Insert	11	109-9147	1	Control-Choke
2	116-7657	1	RH Side Panel ASM	12	109-3958	1	Control-Throttle
2:2	32148-7	1	Nut-Insert	13	116-6630	1	Bracket-Cable, Brake
3	116-6784	1	Plate ASM	14	116-7504	1	Link-Cable, Brake
3:2	121-6164	1	Decal-Warning, Control Panel	15	116-7503	1	Cable-Brake
3:3	121-6162	1	Decal-Warning, Tines	17	3234-29	4	Screw-HHF
3:4	32148-7	2	Nut-Insert	18	3229-1	2	Bolt-CARR
4	116-9142	1	Console ASM	19	104-7201	2	Nut-HF
4:2	121-6166	1	Decal-Danger	20	116-7607	1	Knob-Tee
4:3	116-9132	1	Decal-Danger, Control Panel	21	1-807513	4	Bolt-CARR
6	3231-1	6	Screw-CARR	22	3296-2	4	Nut-Lock, NI
7	104-8301	10	Nut-Flange, NI	24	62-5550	2	Decal
8	3231-2	4	Bolt-CARR	25	1-303335	2	Tie-Plastic
				26	3256-2	2	Washer-Flat

Ground Drive Assembly

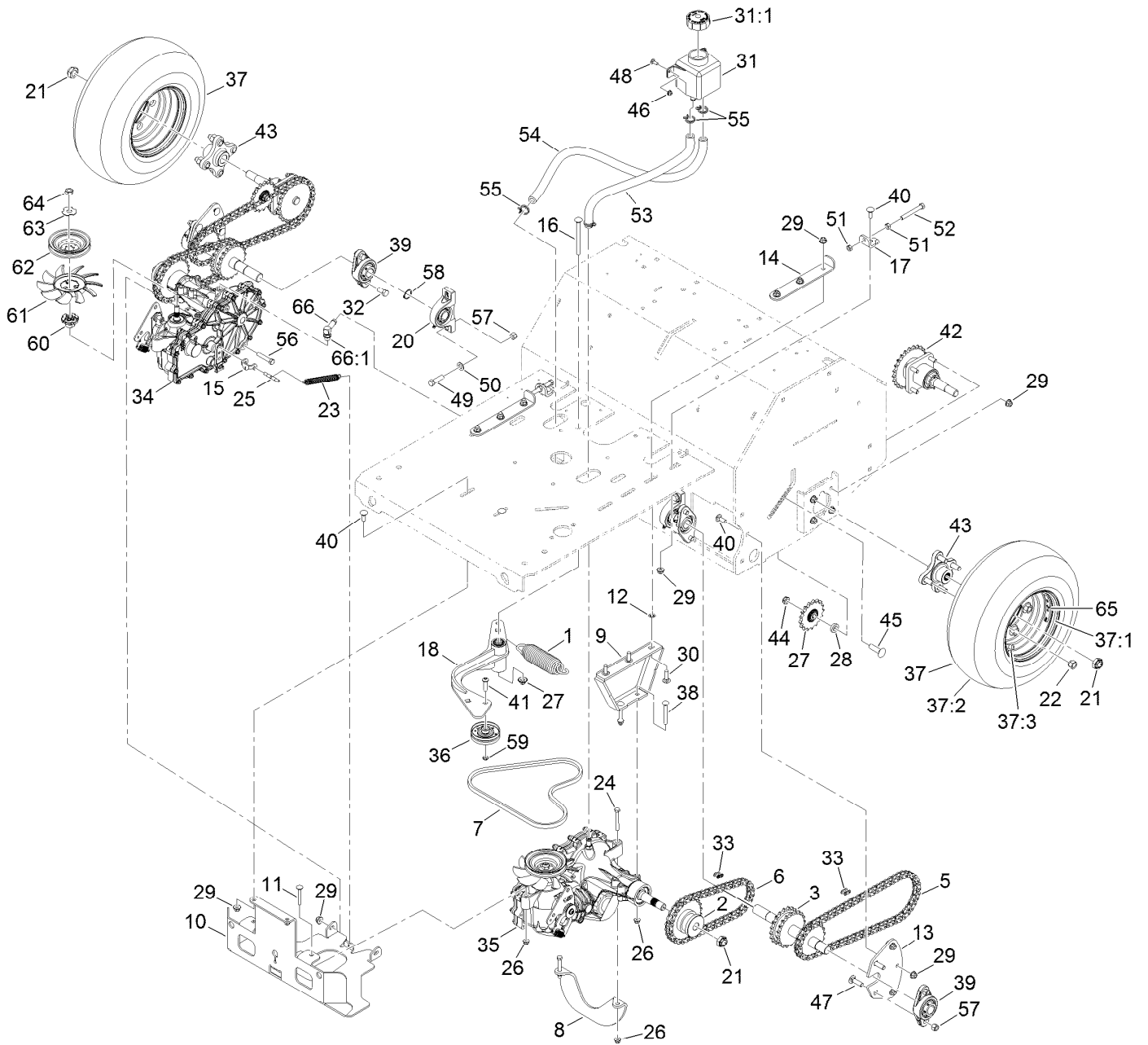

Ground Drive Assembly (continued)

<i>Ref.</i>	<i>Part Number</i>	<i>Qty.</i>	<i>Description</i>	<i>Ref.</i>	<i>Part Number</i>	<i>Qty.</i>	<i>Description</i>
1	116-6317	1	Spring-Extension	37	116-6932	2	Tire ASM (16 X 6.50-8)
2	116-9305	2	Hub-Drive, Chain	37:1	116-6977	1	Rim (8 X 5.375)
3	116-9684	2	Jackshaft	37:2	116-6978	1	Tire (16 X 6.50-8, 4 Ply)
5	116-6895	2	Chain-Roller, #50	37:3	232-27	1	Stem-Valve
6	116-6896	2	Link-#50 Roller Chain, 47	38	3230-9	4	Screw-CARR
7	116-8874	1	Belt-4L Section	39	116-6777	4	Bearing-Flange, 2 Bolt
8	116-9127-03	1	Angle Brace	40	3231-2	10	Bolt-CARR
9	116-9710-03	2	Mount-Transmission	41	116-9927	1	Screw-HSBH
10	116-9711-03	1	Guard-Transmission	42	116-9545	2	Axle And Bearing ASM
11	3230-7	2	Bolt-CARR	43	116-3872	2	Hub-Offset
12	107-3154	6	Nut-Push	44	3296-45	2	Nut-Lock, NI
13	116-6596-01	2	Plate-Jackshaft	45	3233-14	2	Screw-CARR
14	116-6619	2	Plate-Adjustment, Transmission	46	104-7201	2	Nut-HF
15	116-7597	1	Yoke-Park Brake	47	3232-3	4	Bolt-CARR
16	9000779	1	Bolt 3/8-16 X 4 1/2	48	3229-1	2	Bolt-CARR
17	116-6723	2	Bracket-Hydro, Adjust	49	324-6	4	Screw-HH
18	116-9307	1	Idler Arm ASM	50	3256-25	4	Washer-Flat
20	116-6756	2	Bearing-Pillow Block	51	3217-7	4	Nut-Hex
21	116-2839	4	Nut-Lock	52	99-8664	2	Screw-HH
22	242-50	8	Nut-Lug	53	116-6775	1	Hose-Hydraulic
23	76-4660	1	Spring-Door	54	116-6776	1	Hose-Hydraulic
24	322-12	2	Screw-HH	55	109-3322	4	Clamp-Hose
25	116-7596	1	Pin-Brake, Park	56	323-10	2	Screw-HH
26	104-8300	8	Nut-Flange, NI	57	3296-48	8	Nut-Lock, NI
27	116-6719	2	Sprocket-Idler, 17T	58	32151-29	2	Ring-Retaining
28	104-8417	2	Washer	59	3296-59	1	Nut-Lock, NI
29	104-8301	27	Nut-Flange, NI	60	116-9705	2	Hub-Pulley
30	3231-25	6	Bolt-CARR	61	116-9706	2	Fan
31	109-2250	1	Vent-Tank, Hydro	62	116-9707	2	Pulley
31:1	109-3320	1	Cap-Reservoir, HYD	63	116-9708	2	Washer-Slotted
32	116-7109	4	Screw-HH	64	116-9714	2	Nut-Jam, Hex 1/2-20 W/Patch ●
33	116-6897	4	Link-Connecting, #50	65	126-2054	2	Decal-Torque Wheel Lug-Hub
34	116-9712	1	RH Transaxle ASM (No Fan)	66	109-6449	1	Fitting-Elbow, 90
35	116-9713	1	LH Transaxle ASM (No Fan)	66:1	237-42	1	O-Ring
36	116-9715	1	Pulley-Idler				

● Use Pro-Lock, Nut Type (P/N 1-840022, .5ml tube) on threads.

Idler Arm Assembly No. 116-9307

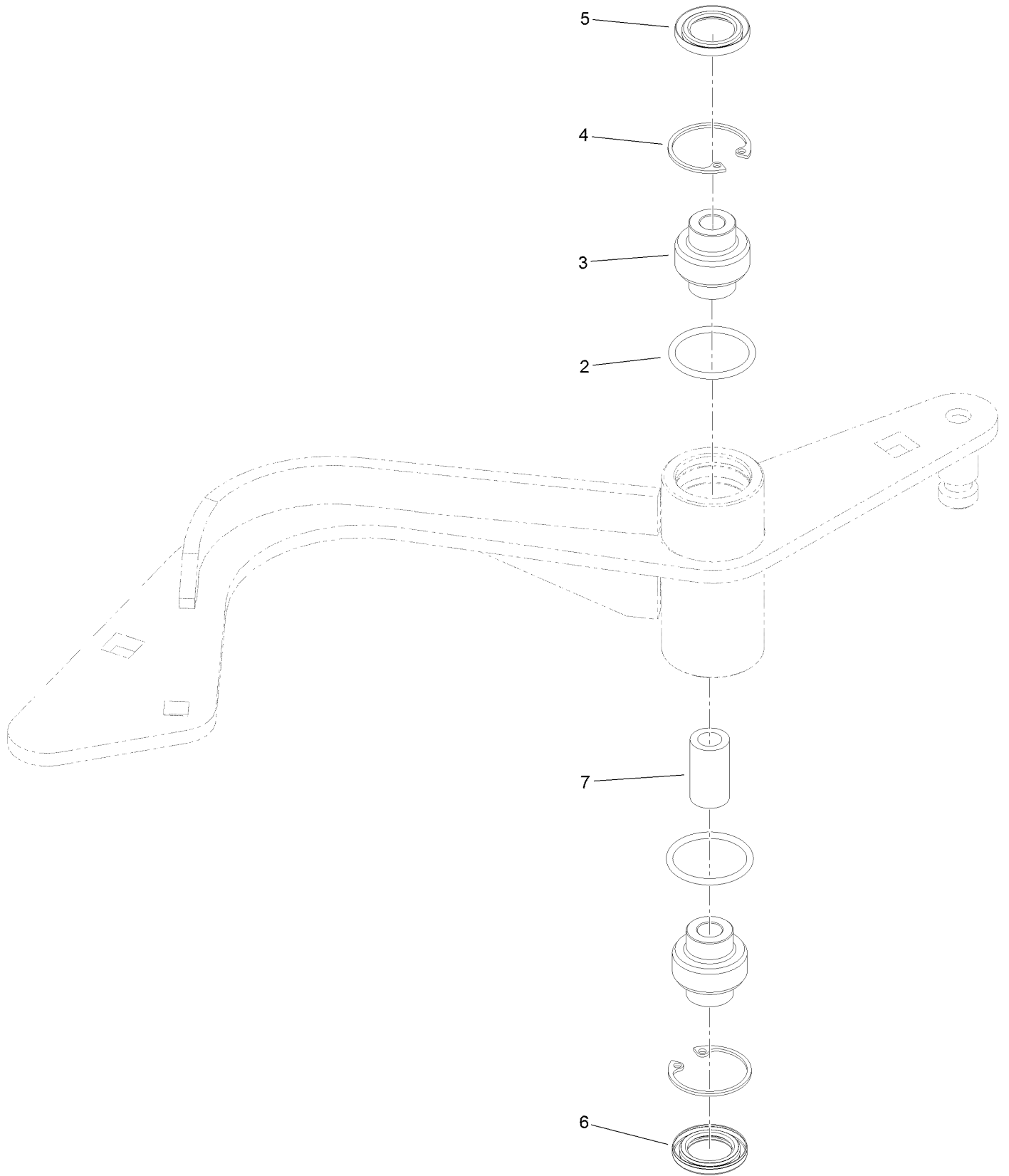

Idler Arm Assembly No. 116-9307 (continued)

<i>Ref.</i>	<i>Part Number</i>	<i>Qty.</i>	<i>Description</i>	<i>Ref.</i>	<i>Part Number</i>	<i>Qty.</i>	<i>Description</i>
2	106-7159	2	O-Ring	5	103-3506	1	Seal-Single Lip
3	103-3504	2	Bearing-Spherical	6	103-3505	1	Seal-Double Lip
4	32120-10	2	Ring-Snap	7	1-603401	1	Spacer-Fender

RH Transaxle Assembly No. 116-9712

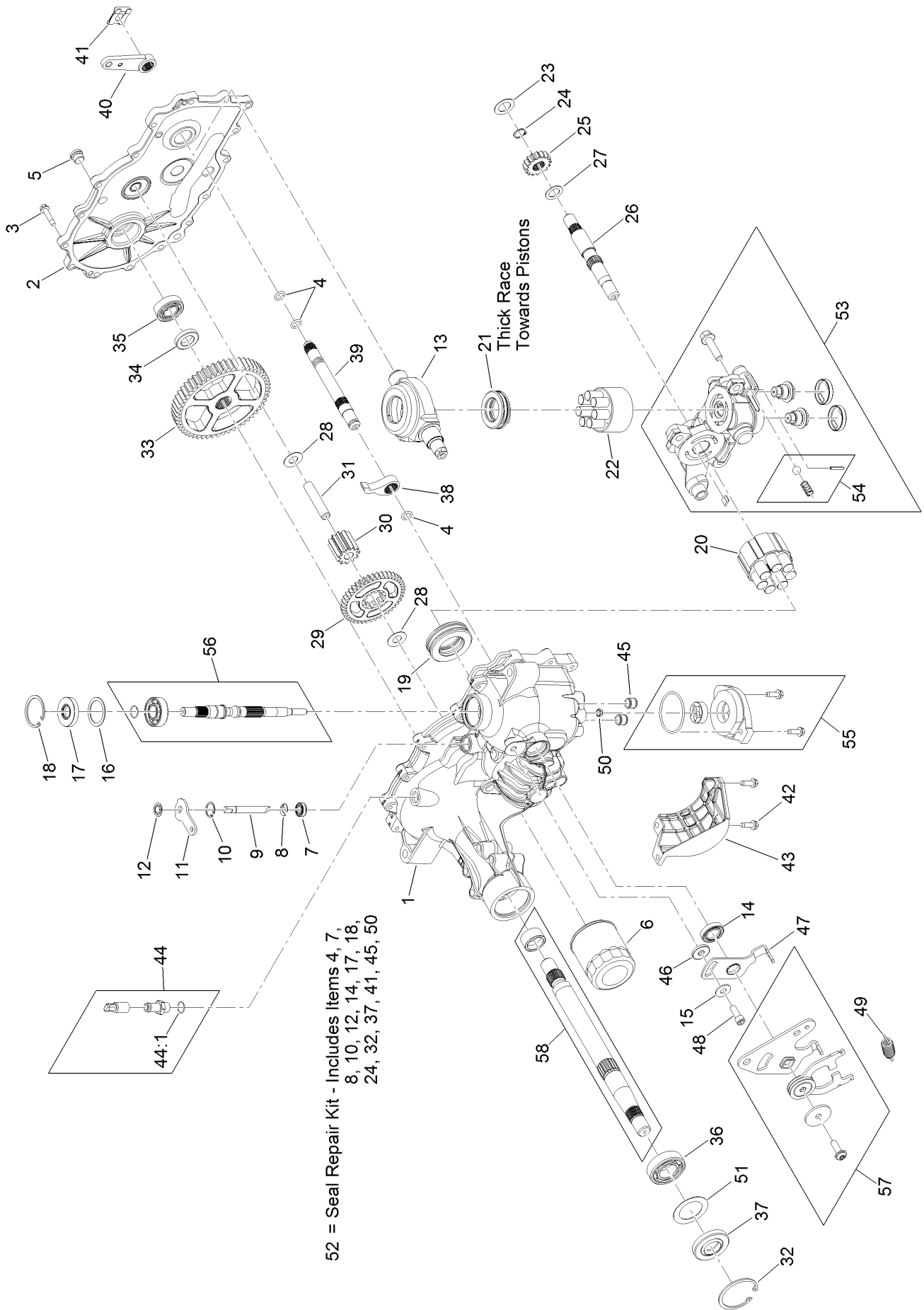

52 = Seal Repair Kit - Includes Items 4, 7,
8, 10, 12, 14, 17, 18,
24, 32, 37, 41, 45, 50

Thick Race
Towards
Pistons

RH Transaxle Assembly No. 116-9712 (continued)

<i>Ref.</i>	<i>Part Number</i>	<i>Qty.</i>	<i>Description</i>	<i>Ref.</i>	<i>Part Number</i>	<i>Qty.</i>	<i>Description</i>
1	114-1676	1	Main Housing Kit	31	104-5329	1	Pin-Jackshaft
2	117-5358	1	Housing Side Kit	32	104-2169	1	Ring-Retaining
3	117-5359	16	Screw-HHF	33	114-1694	1	Gear-54T
4	114-1678	4	O-Ring	34	120-7975	1	Spacer
5	104-2189	1	Plug-Thread, Straight	35	126-0789	1	Bearing-Ball
6	109-3321	1	Element-Oil Filter, HYD	36	120-7976	1	Bearing-Ball
7	106-8676	1	Seal-Lip	37	104-2144	1	Seal
8	106-8677	1	Ring-Retaining, EXT	38	114-1697	1	Pawl-Brake
9	114-1685	1	Rod-Bypass	39	114-1698	1	Shaft-Brake, Inboard
10	106-8679	1	Ring-Retaining, Int	40	125-0021	1	Handle-Brake
11	106-8680	1	Arm-Bypass	41	131-0906	1	Ring-Retaining, EXT
12	106-8681	1	Ring-Retaining, EXT	42	104-2120	3	Screw
13	104-5304	1	Swashplate-Trunnion	43	120-7981	1	Guard-Filter, RH
14	104-5313	1	Seal-Lip	44	109-3278	1	Adapter-Straight
15	114-8491	1	Washer	44:1	237-42	1	O-Ring
16	104-5308	1	Spacer	45	126-3251	2	Tube-Charge
17	104-5310	1	Seal-Lip	46	114-8458	1	Spacer
18	104-5309	1	Ring-Retaining	47	114-8459	1	Arm-Neutral, Right
19	109-2865	1	Bearing-Thrust	48	106-8682	1	Screw-Sh
20	114-1689	1	Motor Cylinder Block Kit	49	115-8307	1	Spring-Extension
21	94-6922	1	Bearing-Thrust	50	131-0908	1	Seal-Gerotor
22	110-8561	1	Pump Block ASM	51	121-5745	1	Spacer
23	104-5339	1	Washer-Flat	52	109-3537	1	Seal Kit
24	104-5340	1	Ring-Retaining	53	120-7982	1	RH Center Section Charge Kit
25	126-0788	1	Gear-16T	54	114-8464	1	Charge Relief Kit
26	114-1691	1	Shaft-Motor	55	114-8465	1	Charge Kit
27	104-5360	1	Washer	56	117-5361	1	Input Shaft Kit
28	94-1933	2	Washer	57	126-2291	1	Control Arm Kit
29	125-0000	1	Gear-43T	58	114-8470	1	Axle Shaft Kit
30	120-7974	1	Gear-11T				

LH Transaxle Assembly No. 116-9713

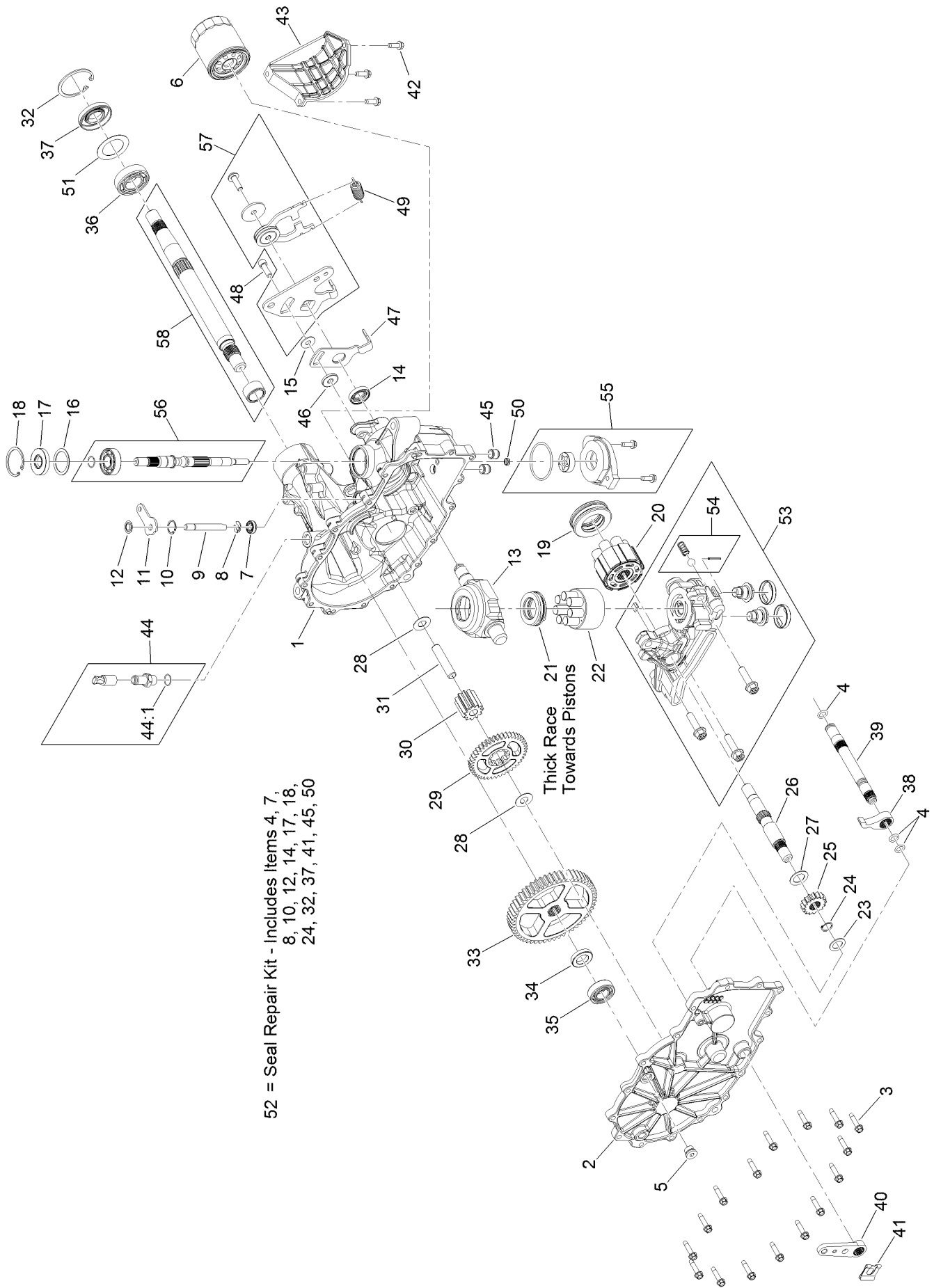

52 = Seal Repair Kit - Includes Items 4, 7, 8, 10, 12, 14, 17, 18, 24, 32, 37, 41, 45, 50

Thick Race 21
Towards Pistons 22

LH Transaxle Assembly No. 116-9713 (continued)

<i>Ref.</i>	<i>Part Number</i>	<i>Qty.</i>	<i>Description</i>	<i>Ref.</i>	<i>Part Number</i>	<i>Qty.</i>	<i>Description</i>
1	114-8471	1	Main Housing Kit	31	104-5329	1	Pin-Jackshaft
2	114-8472	1	Side Cover Kit	32	104-2169	1	Ring-Retaining
3	117-5359	16	Screw-HHF	33	114-1694	1	Gear-54T
4	114-1678	4	O-Ring	34	120-7975	1	Spacer
5	104-2189	1	Plug-Thread, Straight	35	126-0789	1	Bearing-Ball
6	109-3321	1	Element-Oil Filter, HYD	36	120-7976	1	Bearing-Ball
7	106-8676	1	Seal-Lip	37	104-2144	1	Seal
8	106-8677	1	Ring-Retaining, EXT	38	114-1697	1	Pawl-Brake
9	114-1685	1	Rod-Bypass	39	114-1698	1	Shaft-Brake, Inboard
10	106-8679	1	Ring-Retaining, Int	40	125-0021	1	Handle-Brake
11	106-8680	1	Arm-Bypass	41	131-0906	1	Ring-Retaining, EXT
12	106-8681	1	Ring-Retaining, EXT	42	104-2120	3	Screw
13	104-5304	1	Swashplate-Trunnion	43	120-7981	1	Guard-Filter, RH
14	104-5313	1	Seal-Lip	44	109-3278	1	Adapter-Straight
15	114-8491	1	Washer	44:1	237-42	1	O-Ring
16	104-5308	1	Spacer	45	114-8455	2	Tube-Connecting
17	104-5310	1	Seal-Lip	46	114-8458	1	Spacer
18	104-5309	1	Ring-Retaining	47	114-8474	1	Arm-Neutral, Left
19	109-2865	1	Bearing-Thrust	48	106-8682	1	Screw-Sh
20	114-1689	1	Motor Cylinder Block Kit	49	115-8307	1	Spring-Extension
21	94-6922	1	Bearing-Thrust	50	131-0908	1	Seal-Gerotor
22	110-8561	1	Pump Block ASM	51	121-5745	1	Spacer
23	104-5339	1	Washer-Flat	52	109-3537	1	Seal Kit
24	104-5340	1	Ring-Retaining	53	120-7980	1	LH Center Section Charge Kit
25	126-0788	1	Gear-16T	54	114-8464	1	Charge Relief Kit
26	114-1691	1	Shaft-Motor	55	114-8465	1	Charge Kit
27	104-5360	1	Washer	56	117-5361	1	Input Shaft Kit
28	94-1933	2	Washer	57	126-0790	1	Control Arm Kit
29	125-0000	1	Gear-43T	58	114-8470	1	Axle Shaft Kit
30	120-7974	1	Gear-11T				

Axle and Bearing Assembly No. 116-9545

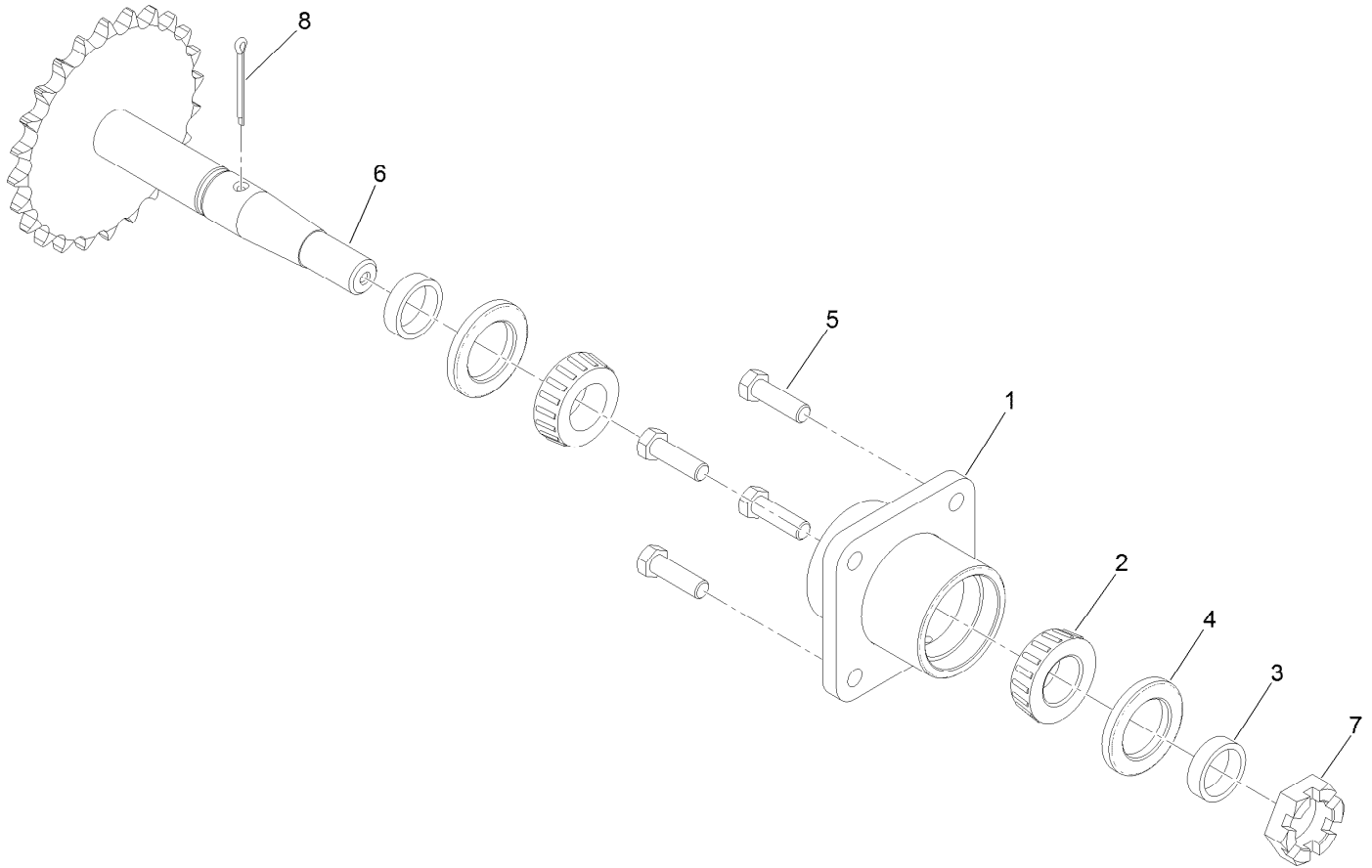

Axle and Bearing Assembly No. 116-9545 (continued)

<i>Ref.</i>	<i>Part Number</i>	<i>Qty.</i>	<i>Description</i>	<i>Ref.</i>	<i>Part Number</i>	<i>Qty.</i>	<i>Description</i>
1	116-6746-01	1	Mount-Bearing, Wheel	5	323-7	4	Screw-HH
2	1-543509	2	Bearing-Roller, Tapered	6	126-0459	1	Axle
3	116-6758	2	Spacer	7	99-3139	1	Nut
4	1-543511	2	Seal-Grease	8	1-806800	1	Pin-Cotter

Tine Assembly

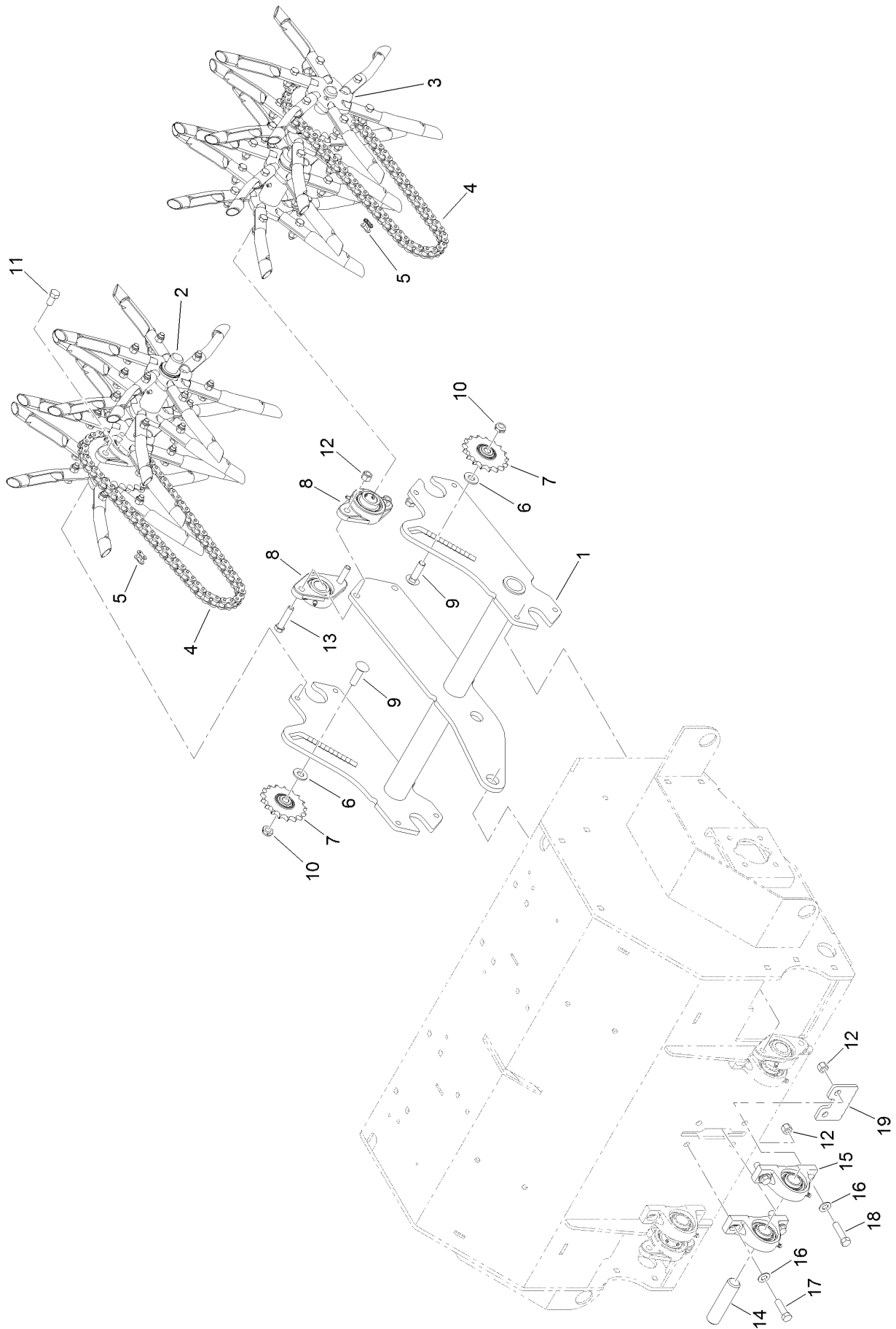

Tine Assembly (continued)

<i>Ref.</i>	<i>Part Number</i>	<i>Qty.</i>	<i>Description</i>	<i>Ref.</i>	<i>Part Number</i>	<i>Qty.</i>	<i>Description</i>
1	116-6553-03	1	Arm-Trail	11	116-7109	4	Screw-HH ●
2	116-6738	1	RH Tine Wheel ASM	12	3296-48	6	Nut-Lock, NI
3	116-6739	1	LH Tine Wheel ASM	13	324-8	2	Screw-HH
4	116-6895	2	Chain-Roller, #50	14	116-6629	1	Shaft
5	116-6897	2	Link-Connecting, #50	15	116-6756	2	Bearing-Pillow Block ●
6	87-7270	2	Washer-Thrust	16	3256-25	4	Washer-Flat
7	116-6719	2	Sprocket-Idler, 17T	17	324-6	2	Screw-HH
8	116-6777	2	Bearing-Flange, 2 Bolt	18	324-7	2	Screw-HH
9	3233-14	2	Screw-CARR	19	116-7327-01	1	Plate-Downstop
10	3296-45	2	Nut-Lock, NI				

● Use Pro-Lock, Nut Type (P/N 1-840022, .5ml tube) on threads.

RH Tine Wheel Assembly No. 116-6738

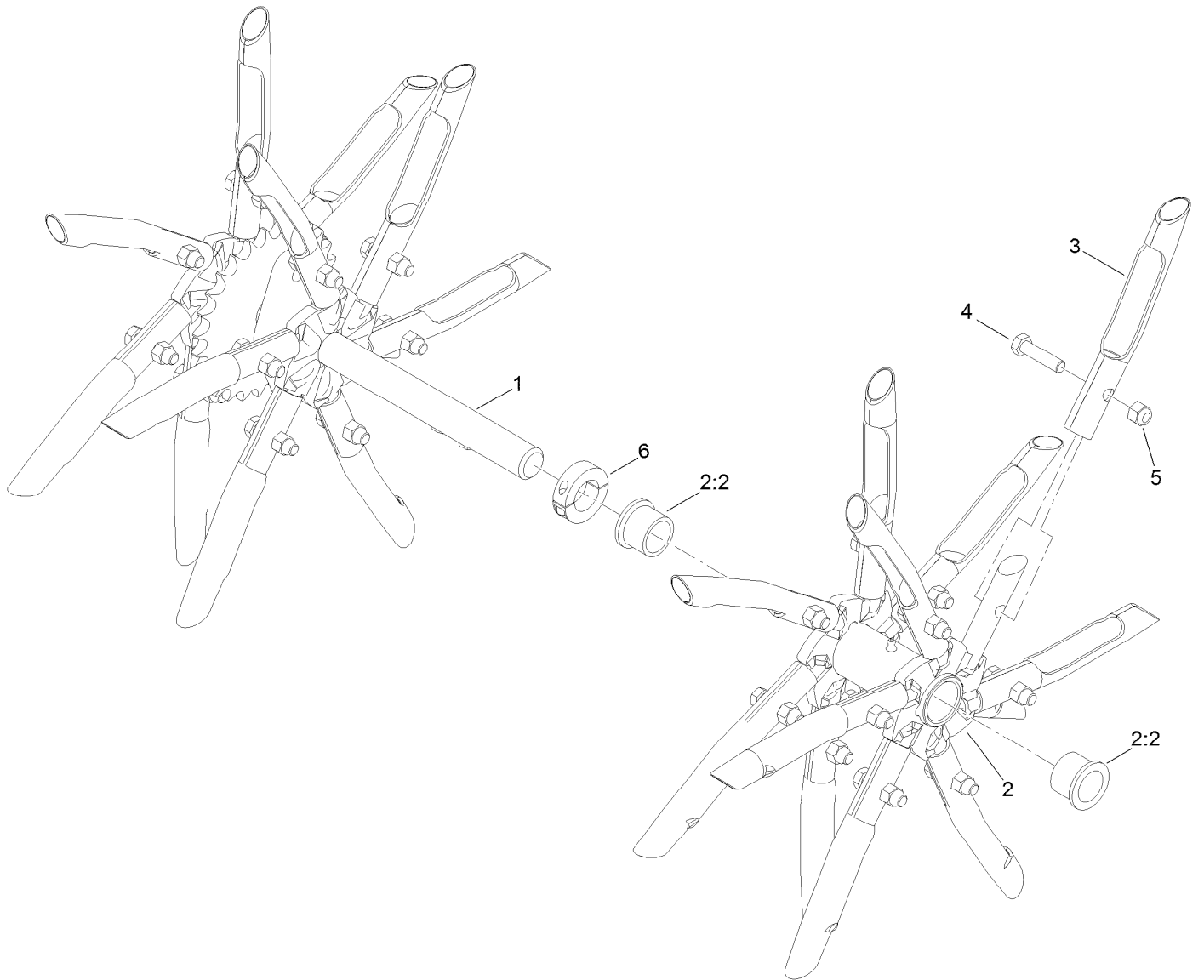

RH Tine Wheel Assembly No. 116-6738 (continued)

<i>Ref.</i>	<i>Part Number</i>	<i>Qty.</i>	<i>Description</i>	<i>Ref.</i>	<i>Part Number</i>	<i>Qty.</i>	<i>Description</i>
1	116-6727	1	Shaft-Tine, RH	4	323-8	24	Screw-HH
2	116-6731	1	Float Tine Shaft ASM	5	3296-39	24	Nut-Lock, NI
2:2	94-8949	2	Bushing-Flange	6	116-7271	1	Collar-Locking ●
3	126-0262	24	Tine-Coring				

● Use Loctite® 243 on threads.

LH Tine Wheel Assembly No. 116-6739

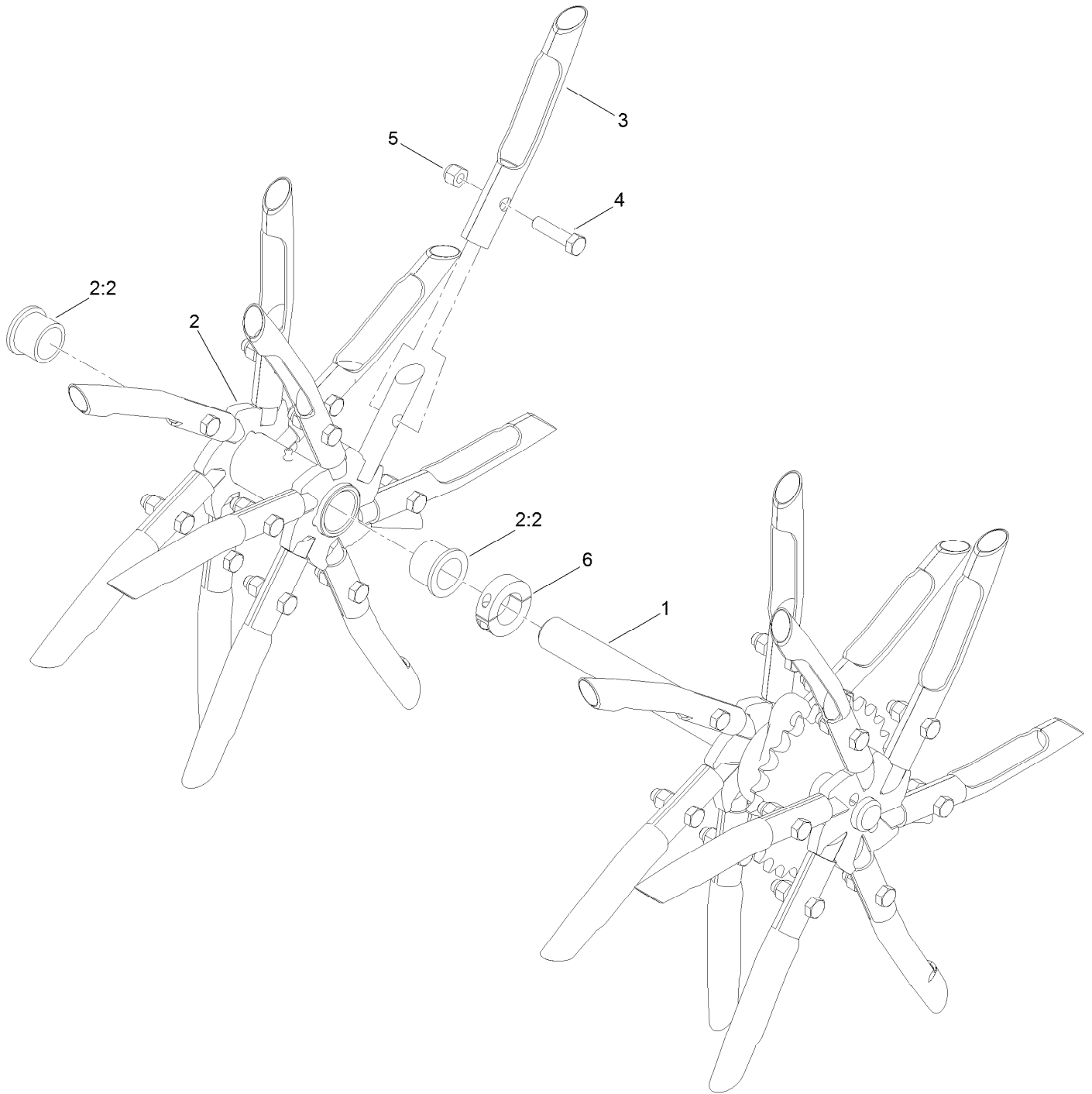

LH Tine Wheel Assembly No. 116-6739 (continued)

<i>Ref.</i>	<i>Part Number</i>	<i>Qty.</i>	<i>Description</i>	<i>Ref.</i>	<i>Part Number</i>	<i>Qty.</i>	<i>Description</i>
1	116-6728	1	Shaft-Tine, LH	4	323-8	24	Screw-HH
2	116-6731	1	Float Tine Shaft ASM	5	3296-39	24	Nut-Lock, NI
2:2	94-8949	2	Bushing-Flange	6	116-7271	1	Collar-Locking ●
3	126-0262	24	Tine-Coring				

● Use Loctite® 243 on threads.

Fuel Assembly

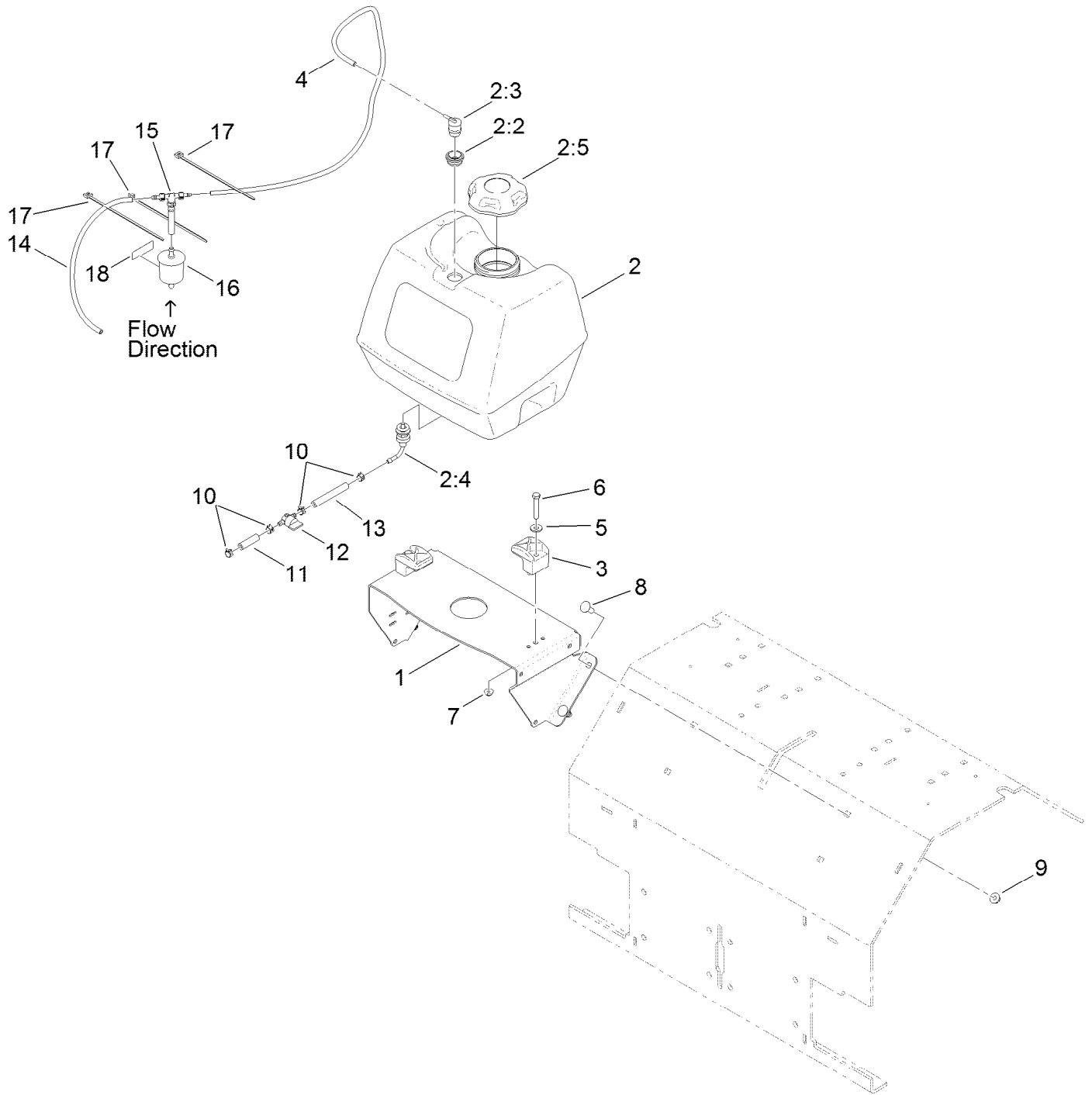

Fuel Assembly (continued)

<i>Ref.</i>	<i>Part Number</i>	<i>Qty.</i>	<i>Description</i>	<i>Ref.</i>	<i>Part Number</i>	<i>Qty.</i>	<i>Description</i>
1	116-9541-01	1	Support-Tank, Fuel	8	3231-22	4	Screw-CARR
2	126-1526	1	Fuel Tank ASM	9	104-8301	4	Nut-Flange, NI
2:2	114-0284	1	Grommet	10	2412-98	4	Clamp-Hose
2:3	119-3547	1	Valve-Vent, Fuel	11	119-7856	1	Hose-Fuel
2:4	103-2605	1	Fitting-Fuel, Bulkhead	12	1-603770	1	Valve-Fuel
2:5	120-5461	1	Cap-Fuel, Ratcheting	13	105-8342	1	Hose-Fuel
3	107-4543	2	Clamp	14	115-7872	1	Hose-Fuel
4	116-4346	1	Hose-Emissions	15	116-5464	1	Tee And Check
5	3256-3	2	Washer-Flat	16	120-2235	1	Filter-Fuel
6	322-10	2	Screw-HH	17	1-303335	3	Tie-Plastic
7	104-8300	2	Nut-Flange, NI	18	116-4769	1	Decal-Filter, Emissions

Motion Control Assembly

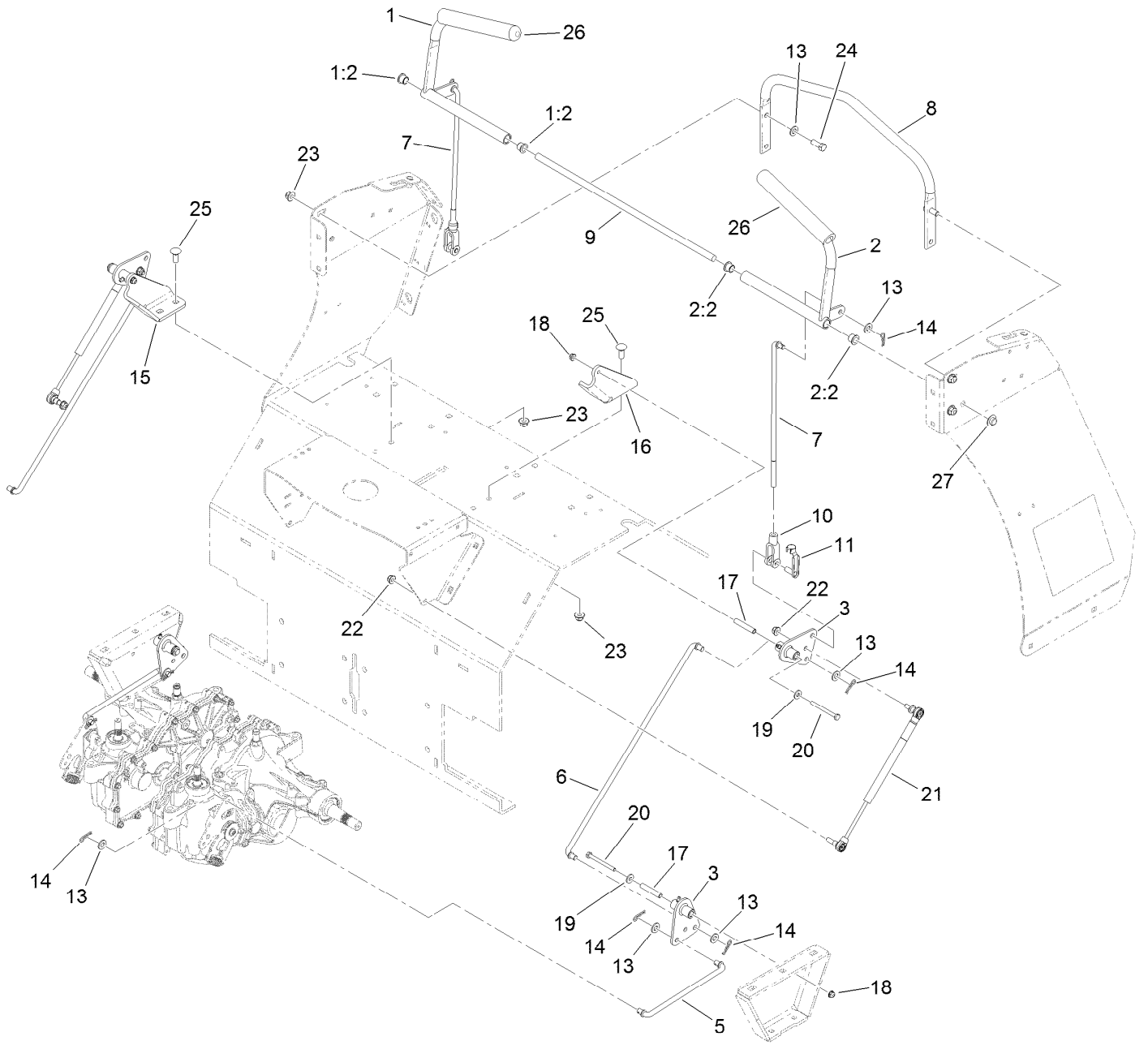

Motion Control Assembly (continued)

<i>Ref.</i>	<i>Part Number</i>	<i>Qty.</i>	<i>Description</i>	<i>Ref.</i>	<i>Part Number</i>	<i>Qty.</i>	<i>Description</i>
1	116-6567	1	RH Control Handle ASM	15	116-6576-03	1	Bracket-Pivot, RH
1:2	116-4279	2	Bearing-Flange	16	116-6577-03	1	Bracket-Pivot, LH
2	116-6566	1	LH Control Handle ASM	17	116-7224	4	Spacer
2:2	116-4279	2	Bearing-Flange	18	104-7201	4	Nut-Nyloc 1/4-20 Flg
3	126-0340	4	Bellcrank W/Zerk	19	3256-2	4	Washer-1/4 Std
5	116-6722	2	Link-Control, Hydro	20	321-14	4	Screw-HH 1/4-20 X 2 3/4
6	116-9298	2	Link-Control, Bell Crank	21	116-0027	2	Damper-Control, Motion
7	116-6730	2	Link-Control, Bell Crank	22	104-8300	4	Nut-Nyloc 5/16-18 Flg
8	116-6608-03	1	Bar-Reference	23	104-8301	8	Nut-Nyloc 3/8-16 Flg
9	116-6607	1	Shaft-Pivot, Control	24	323-6	4	Screw-HH 3/8-16 X 1
10	1-633131	2	Yoke-Linkage, Brake	25	3231-2	4	Bolt-Carriage 3/8-16 X 1
11	103-2399	2	Pin-Clevis Spring 3/8	26	103-8153	2	Grip-Lever, Control
13	3256-24	14	Washer-3/8 Sae	27	32112-14	2	Nut-Push
14	1-806003	10	Hairpin-Cotter				

Electrical Assembly

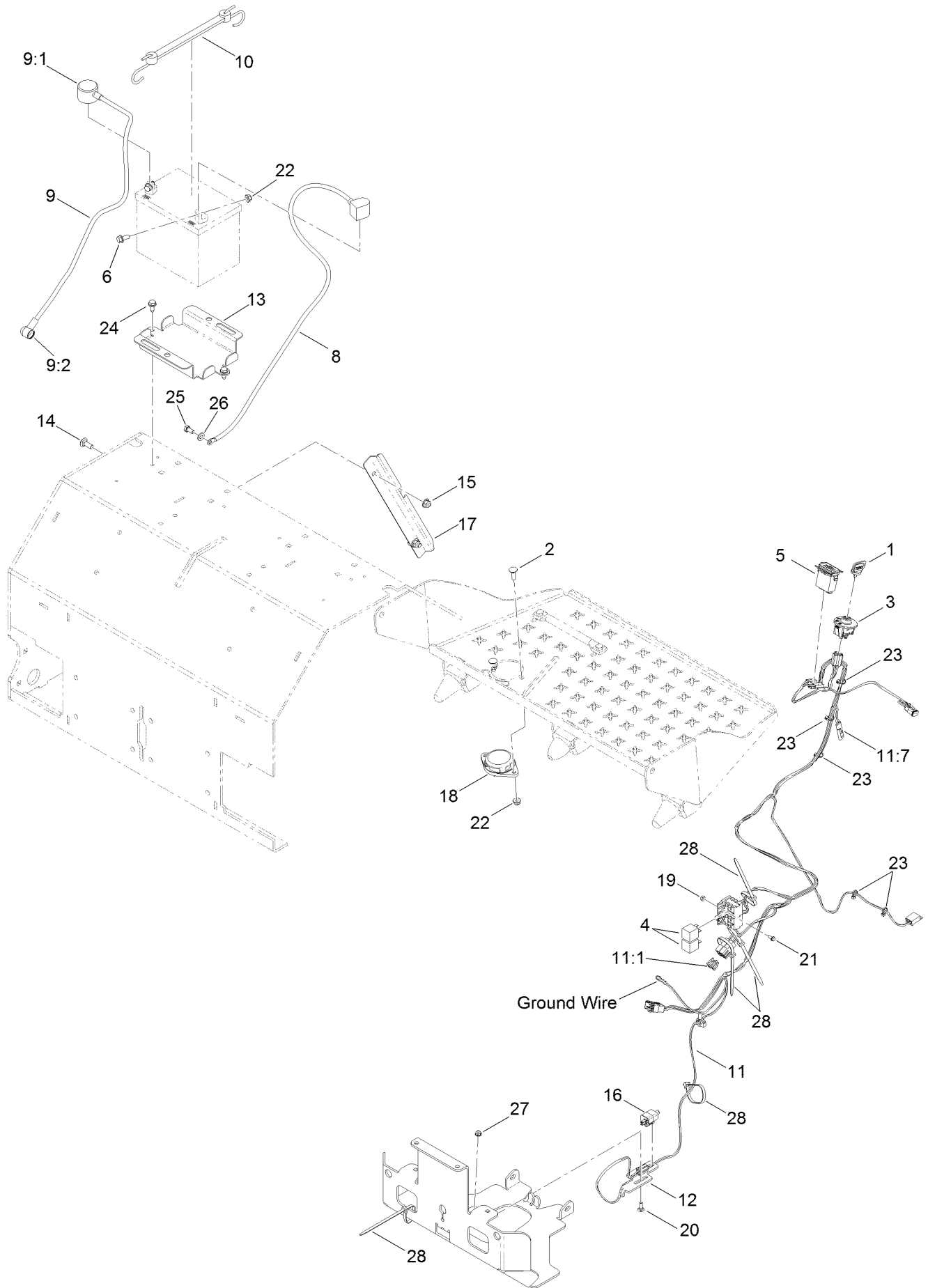

Electrical Assembly (continued)

<i>Ref.</i>	<i>Part Number</i>	<i>Qty.</i>	<i>Description</i>	<i>Ref.</i>	<i>Part Number</i>	<i>Qty.</i>	<i>Description</i>
1	1-603511	1	Keys-Ignition (Spare Pair)	13	116-9383-03	1	Bracket-Battery
1	63-8360	1	Key-Ignition	14	3231-2	2	Bolt-CARR
2	3230-2	2	Bolt-CARR	15	104-8301	2	Nut-Flange, NI
3	117-2221	1	Switch-Ignition	16	110-6765	1	Switch-Single Pole No
4	1-643275	2	Relay	17	116-9394-03	1	Guard-Harness
5	1-513374	1	Meter-Hour	18	92-6282	1	Switch-Seat
6	3234-5	2	Screw-HHF	19	3296-2	2	Nut-Lock, NI
8	117-6422	1	Cable-Battery, Black	20	3229-1	1	Bolt-CARR
9	109-7630	1	Positive Battery Cable ASM	21	3290-321	2	Screw-HWH
9:1	109-2407	1	Insulator-Battery	22	104-8300	4	Nut-Flange, NI
9:2	1-543393	1	Insulator-Solenoid	23	1-303287	5	Tie-Cable
10	104-2466	1	Holddown-Battery	24	32144-70	2	Screw-HWHTF
11	116-9382	1	Harness ASM	25	33114-016	1	Screw-HH
11:1	1-816001	2	Fuse-Blade Type, 20 Amp	26	33094-00	1	Washer-Plain
11:7	116-0053	1	Cap-Plug	27	104-7201	1	Nut-HF
12	116-7589	1	Mount-Switch	28	1-303335	5	Tie-Plastic

Auxiliary Hydraulic Assembly

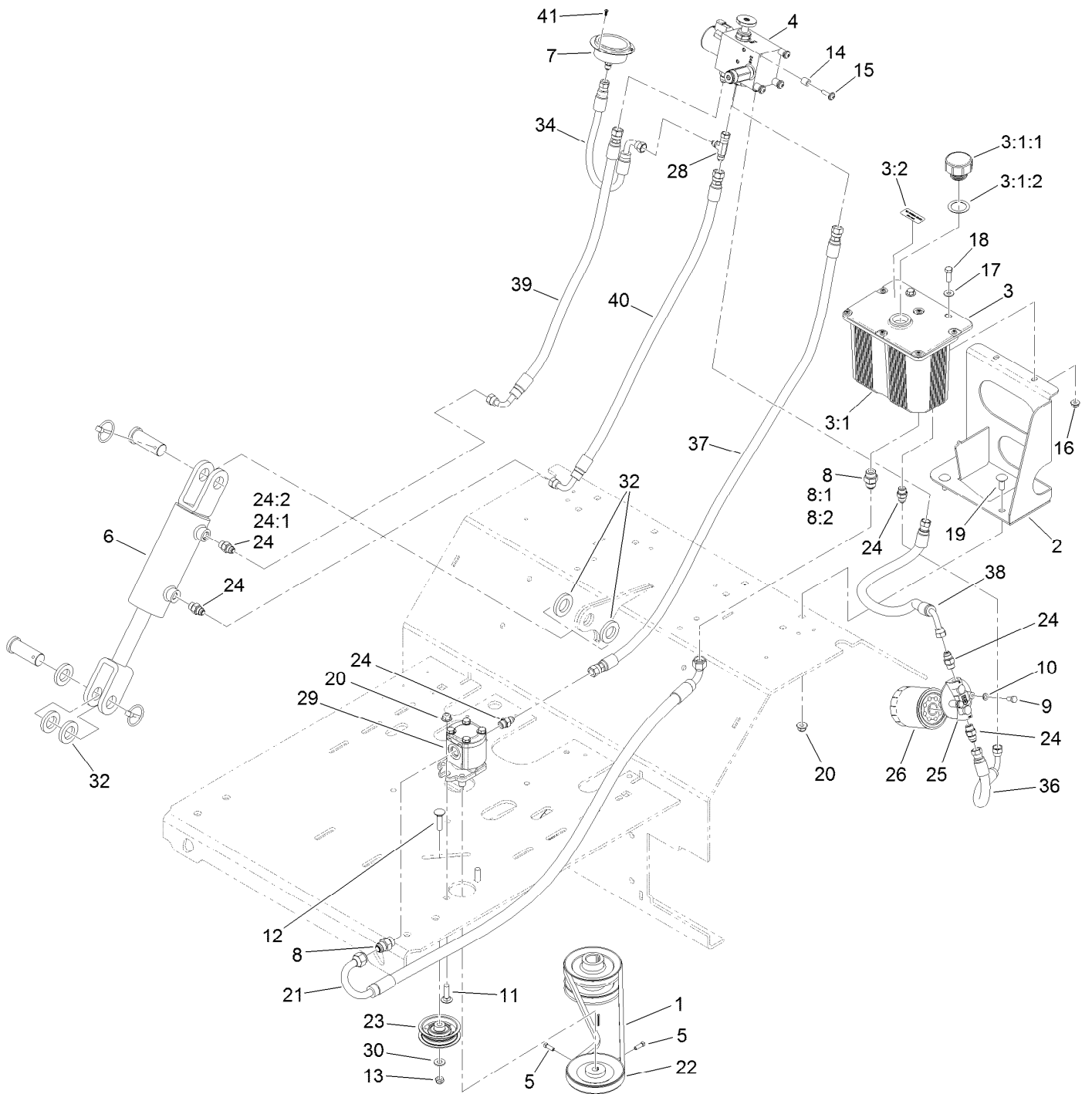

Auxiliary Hydraulic Assembly (continued)

<i>Ref.</i>	<i>Part Number</i>	<i>Qty.</i>	<i>Description</i>	<i>Ref.</i>	<i>Part Number</i>	<i>Qty.</i>	<i>Description</i>
1	116-8874	1	Belt-4L Section	18	322-5	2	Screw-HH
2	116-6618-03	1	Bracket-Tank, Hydraulic	19	3231-2	4	Bolt-CARR
3	116-7557	1	Reservoir ASM	20	104-8301	6	Nut-Flange, NI
3:1		1	Tank-Hydraulic ●	21	116-9309	1	Hose-Hydraulic
3:1:1	103-1948	1	Cap-Reservoir, HYD	22	116-6667	1	Pulley
3:1:2	103-1949	1	Gasket-Cap	23	116-6760	1	Pulley-Idler, Flat
3:2	93-6686	1	Decal-Oil, HYD	24	103-2156	6	Fitting-Straight
4	116-9549	1	Valve-Manifold	24:1	1-603921	1	O-Ring
5	3241-6	2	Screw-SQH ■	24:2	103-1020	1	O-Ring
6	116-6969	1	HYD Cylinder ASM	25	104-7836	1	Head-Filter
7	116-8178	1	Gauge-Pressure	26	1-633750	1	Filter-Oil, HYD
8	1-603990	2	Fitting-Straight	28	353-877	1	Fitting-HYD, Tee (Swivel)
8:1	1-603920	1	O-Ring	29	116-9129	1	Hydraulic Pump ASM
8:2	1-603992	1	O-Ring	30	3256-24	1	Washer-Flat
9	321-3	2	Screw-HH	32	116-6781	5	Spacer
10	1-805004	2	Washer-Lock	34	116-8180	1	Hose-Hydraulic, Hp
11	3231-25	2	Bolt-CARR	36	116-6675	1	Hose-Hydraulic, LP
12	3231-4	1	Screw-CARR	37	116-8151	1	Hose-Hydraulic
13	3296-59	1	Nut-Lock, NI	38	116-9308	1	Hose-Hydraulic
14	22-7810	4	Spacer	39	116-6677	1	Hose-Hydraulic
15	110-9361	4	Screw-PPH, Sems	40	116-6678	1	Hose-Hydraulic, Hp
16	104-8300	2	Nut-Flange, NI	41	363-8552	3	Screw-TAP
17	3256-2	2	Washer-Flat				

● Not serviced separately

■ Use Pro-Lock, Nut Type (P/N 1-840022, .5ml tube) on threads.

Manifold W/Check and Relief Valve Assembly No. 116-9549

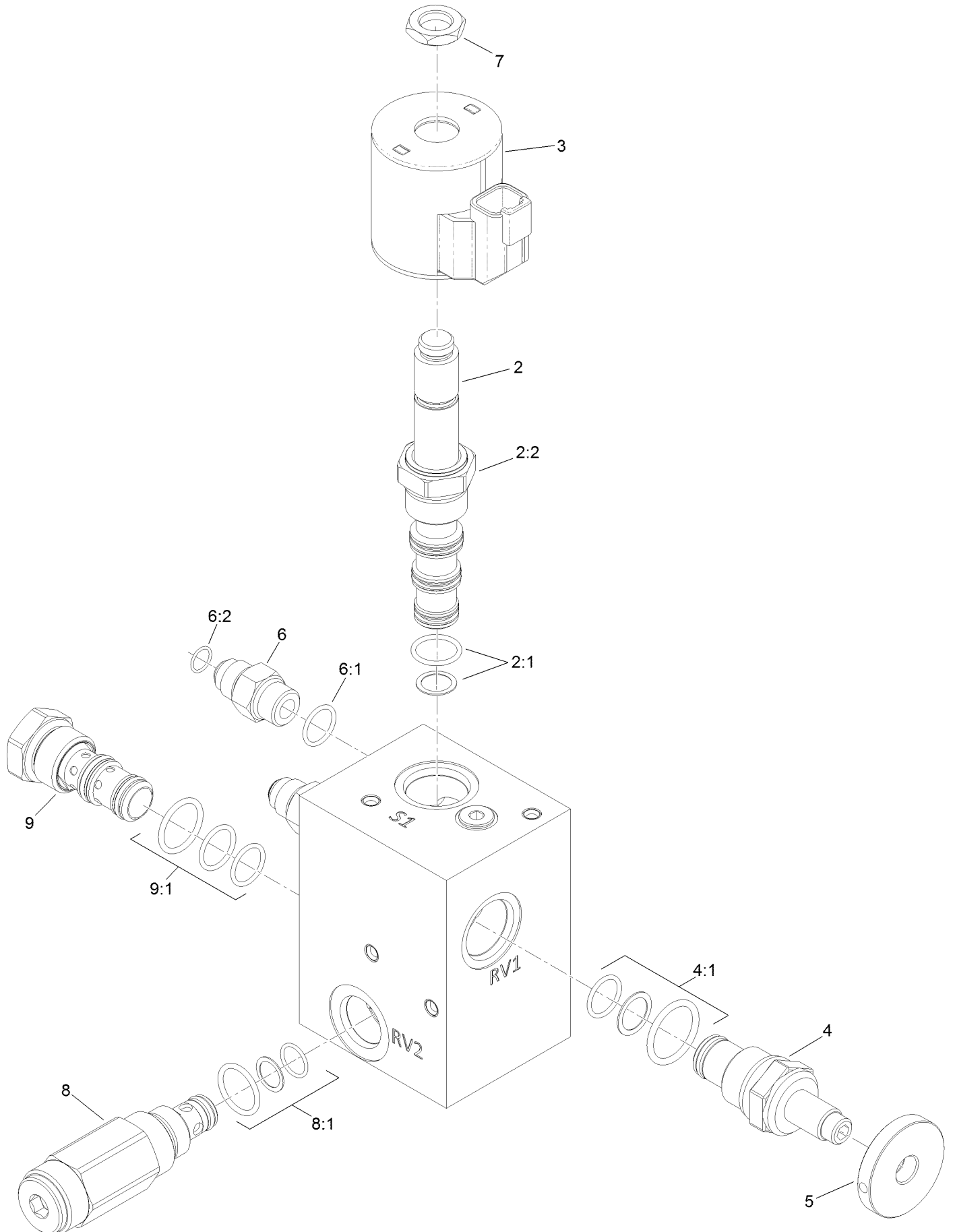

Manifold W/Check and Relief Valve Assembly No. 116-9549 (continued)

<i>Ref.</i>	<i>Part Number</i>	<i>Qty.</i>	<i>Description</i>	<i>Ref.</i>	<i>Part Number</i>	<i>Qty.</i>	<i>Description</i>
2	110-8906	1	Valve-Solenoid	6:1	1-603921	1	O-Ring
2:1	110-8908	1	Spool Valve Seal Kit	6:2	103-1020	1	O-Ring
2:2	110-2634	1	Nut-Coil	7	110-2634	1	Nut-Coil
3	119-4619	1	Coil-Solenoid	8	116-9716	1	Valve-Relief
4	116-9397	1	Valve-Relief, Poppet Style	8:1	116-9717	1	Seal Kit
4:1	116-9398	1	Relief Valve Seal Kit	9	116-9718	1	Valve-Check, P O
5	116-9396	1	Knob (1.5 Dia)	9:1	116-9719	1	Seal Kit
6	103-2156	4	Fitting-Straight				

Hydraulic Cylinder Assembly No. 116-6969

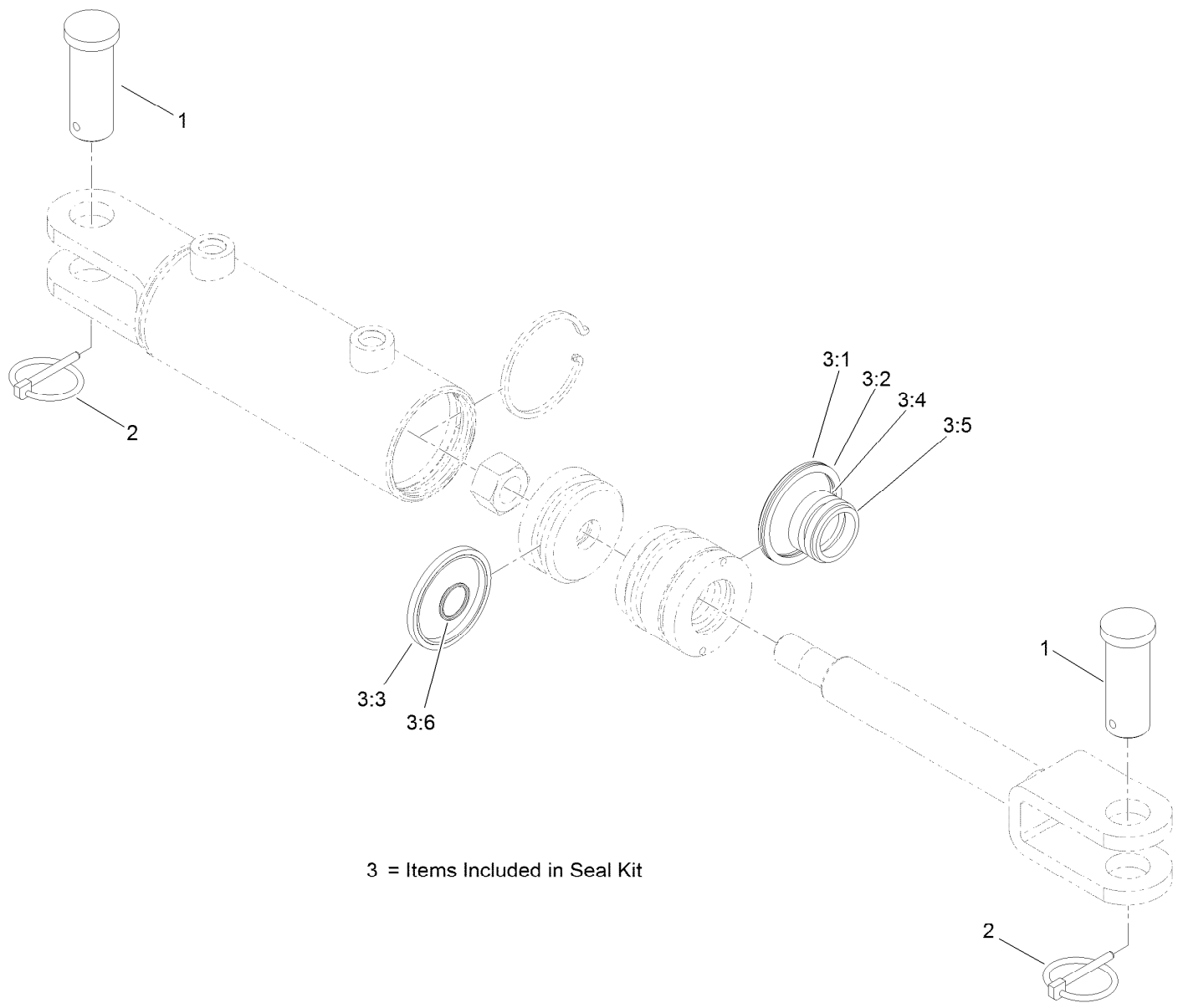

3 = Items Included in Seal Kit

Hydraulic Cylinder Assembly No. 116-6969 (continued)

<i>Ref.</i>	<i>Part Number</i>	<i>Qty.</i>	<i>Description</i>	<i>Ref.</i>	<i>Part Number</i>	<i>Qty.</i>	<i>Description</i>
1	116-7290	2	Pin-Clevis	3:3		1	Psp Seal ●
2	92-1298	2	Pin-Lynch	3:4		1	Bs Seal ●
3	127-3234	1	Seal Kit	3:5		1	Dust Seal ●
3:1		1	O-Ring ●	3:6		1	O-Ring ●
3:2		1	Backup Ring ●				

● Not serviced separately

Hydraulic Pump Assembly No. 116-9129

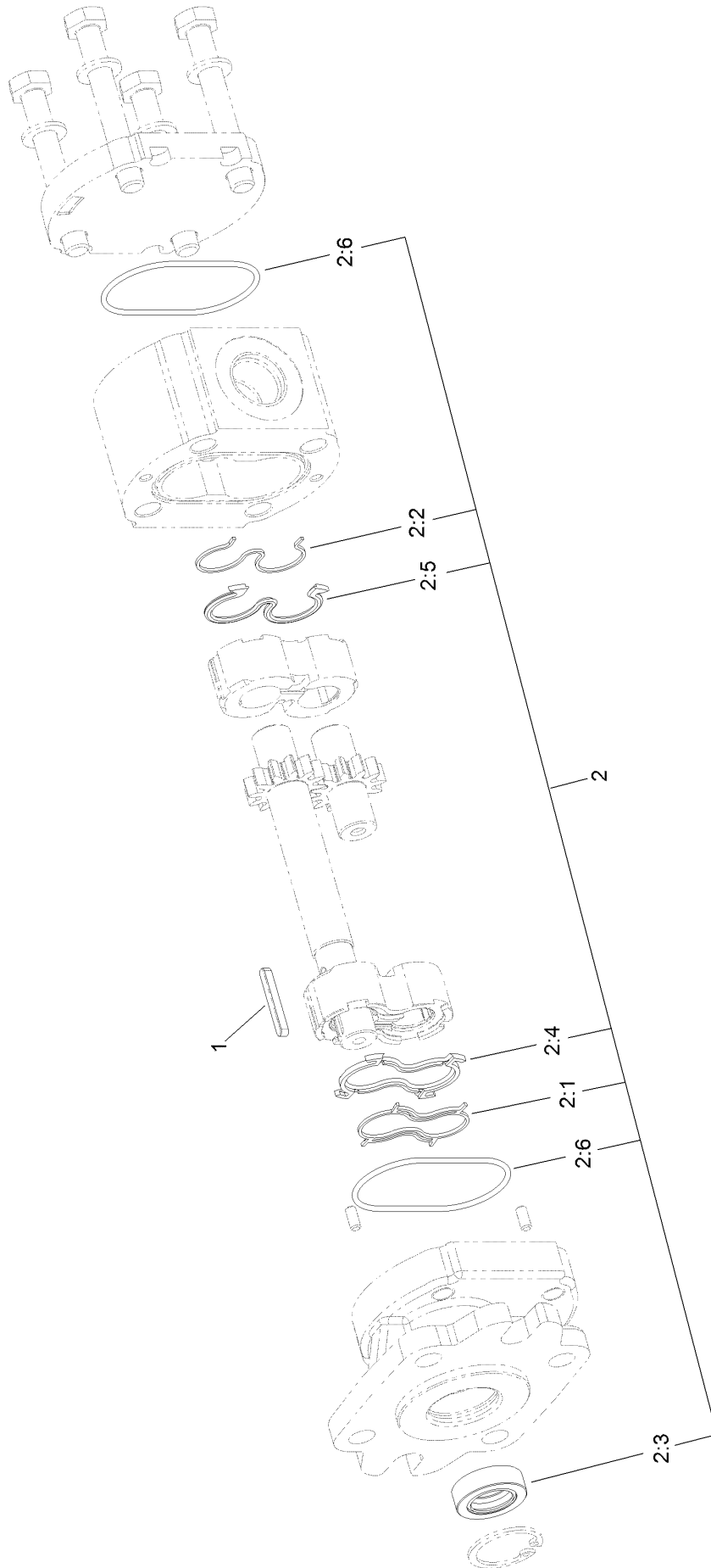

Hydraulic Pump Assembly No. 116-9129 (continued)

<i>Ref.</i>	<i>Part Number</i>	<i>Qty.</i>	<i>Description</i>	<i>Ref.</i>	<i>Part Number</i>	<i>Qty.</i>	<i>Description</i>
1	115-7855	1	Key-Square	2:3		1	Seal-Shaft ●
2	112-0199	1	Seal Kit	2:4		1	Seal-Upper ●
2:1		1	Seal-Anti Extrusion ●	2:5		1	Seal ●
2:2		1	Seal-Anti Extrusion ●	2:6		2	O-Ring ●

● Not serviced separately

Engine Assembly

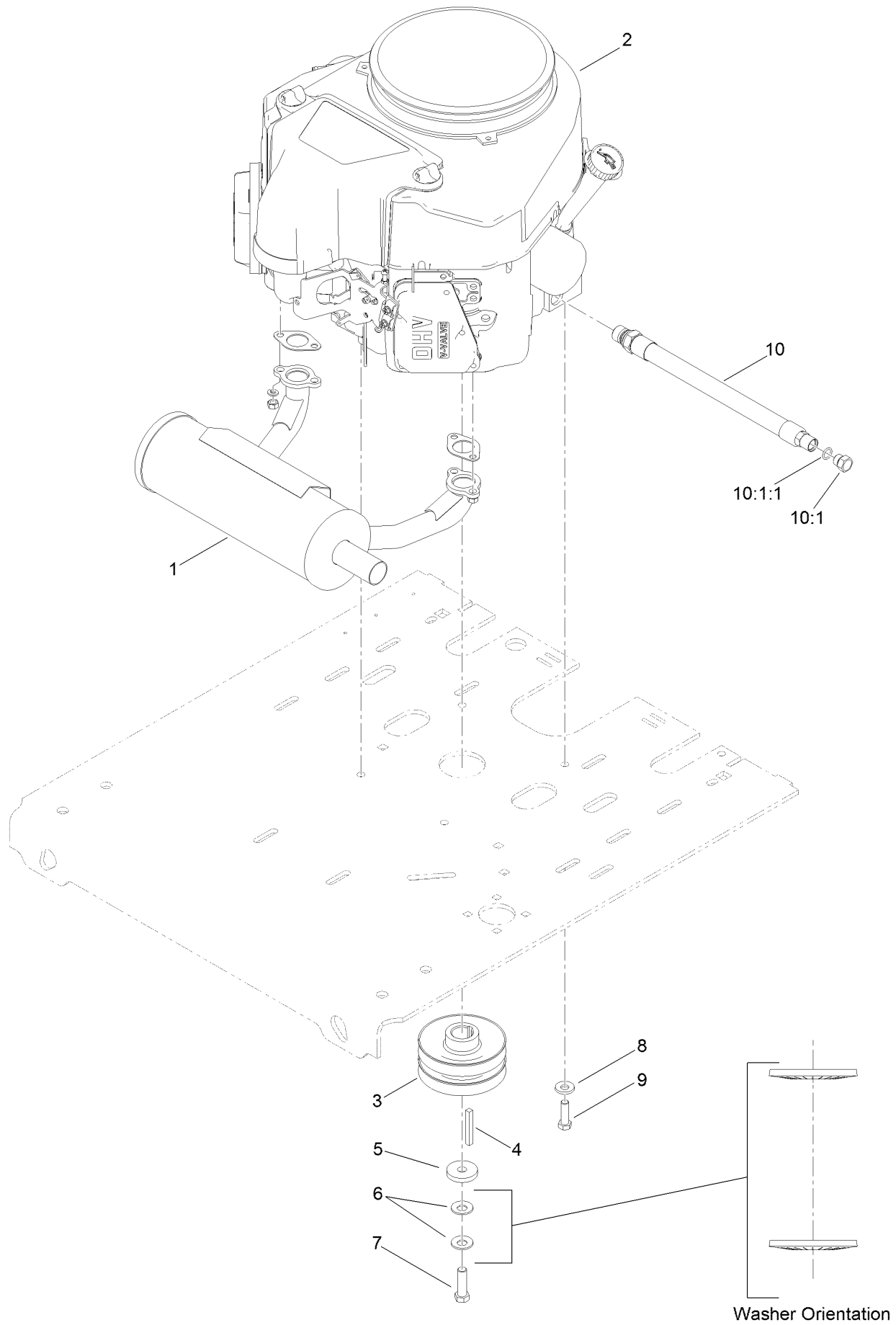

Engine Assembly (continued)

<i>Ref.</i>	<i>Part Number</i>	<i>Qty.</i>	<i>Description</i>	<i>Ref.</i>	<i>Part Number</i>	<i>Qty.</i>	<i>Description</i>
1	116-3735	1	Muffler-Horizontal	7	109-9761	1	Screw-HH ♦
2		1	Engine-Kawasaki, Fs481V_s25-R ●■	8	98-5975	4	Washer-Belleville
3	116-9709	1	Pulley	9	323-7	4	Screw-HH
4	103-4177	1	Key	10	116-4924	1	Engine Oil Drain Hose ASM ▲
5	1-543610	1	Washer-Clutch	10:1	353-508	1	Plug-HH
6	1-603610	2	Washer-Spring	10:1:1	237-42	1	O-Ring

● Not serviced separately

▲ Use a Teflon Pipe Sealant or equivalent on threads.

♦ Use Pro-Lock, Nut Type (P/N 1-840022, .5ml tube) on threads.

■ Obtain parts from www.kawpowerepc.com

Notes:

Notes:



Count on it.