



Count on it.

Parts Catalog

MM-650E-S Mortar Mixer

Model No. 68012—Serial No. 314000001 and Up



Ordering Replacement Parts

To order replacement parts, please supply the part number, the quantity, and the description of each part desired.

Understanding Reference Numbers

Each identified part in an illustration has a reference number. The reference number for a part also appears in the parts list, along with other information about the part.

This catalog uses two special reference number formats, one to indicate parts in a service assembly and another to indicate the quantity of a given part in an illustration.

Service Assembly Reference Numbers

Parts in service assemblies have reference numbers in the form a:b. The a represents the reference number of the entire service assembly and the b represents a sequential number unique to each part within the service assembly.

For example, a wheel assembly might be identified by reference number 6, the tire by 6:1, the valve by 6:2, and the wheel by 6:3. When you order the assembly identified by reference number 6, you receive all parts identified by reference numbers 6:1, 6:2, and 6:3. However, you may also order any part individually. Reference numbers of this type appear in illustration and in parts lists.

Reference Numbers Indicating Quantity

In an illustration, if a reference number indicates more than one part, the reference number has the form nX y. The n represents the quantity of the part, the X is the multiplication symbol, and the y represents the reference number.

For example, in an illustration, the reference number 2X 37 means that two of the parts identified by reference number 37 are indicated.

List of Abbreviations

AR: as required	HLH: hex lag head	PTO: power-take-off
ASM: assembly	HOC: height-of-cut	RH: right hand
BBC: blade brake control	HSBH: hex socket button head	ROPS: roll-over protection system
BHTF: button head thread forming	HSFH: hex socket flat head	RRB: rear roller brush
CARR: carriage	HSH: hex socket head	SFH: slotted fillister head
CCW: counter clockwise	HWH: hex washer head	SHH: slotted hex head
CW: clockwise	HWHTF: hex washer head thread forming	SHWH: slotted hex washer head
DEG: degrees	HYD: hydraulic	SPH: slotted pan head
DPA: Dual Point Adjustment	LH: left hand	SQH: square head
ECM: electronic control module	LP: Liquefied Petroleum Gas	SRH: slotted round head
EXT: external	LPG: Liquefied Petroleum Gas	STD: standard
FH: flat head	NI: nylon insert	TAP: self tapping
GA: gauge	NPTF: national pipe thread fine	TTH: torx truss head
HD: heavy-duty	PFH: phillips flat head	
HF: hex flange	PPH: phillips pan head	
HH: hex head	PPHTF: phillips pan head thread forming	
HHF: hex head flange	PRH: phillips round head	
HHFTF: hex head flange thread forming	PTH: phillips truss head	
HJ: hex jam		

Contents

Frame and Axle Assembly	4
Hub Assembly No. 125-8171	6
Drum Assembly	8
Electric Motor Assembly	10
Pinion Assembly No. ST32354	12
Idler Assembly No. ST21300	14
Cowl Assembly	16
Attachments and Accessories	18

Frame and Axle Assembly

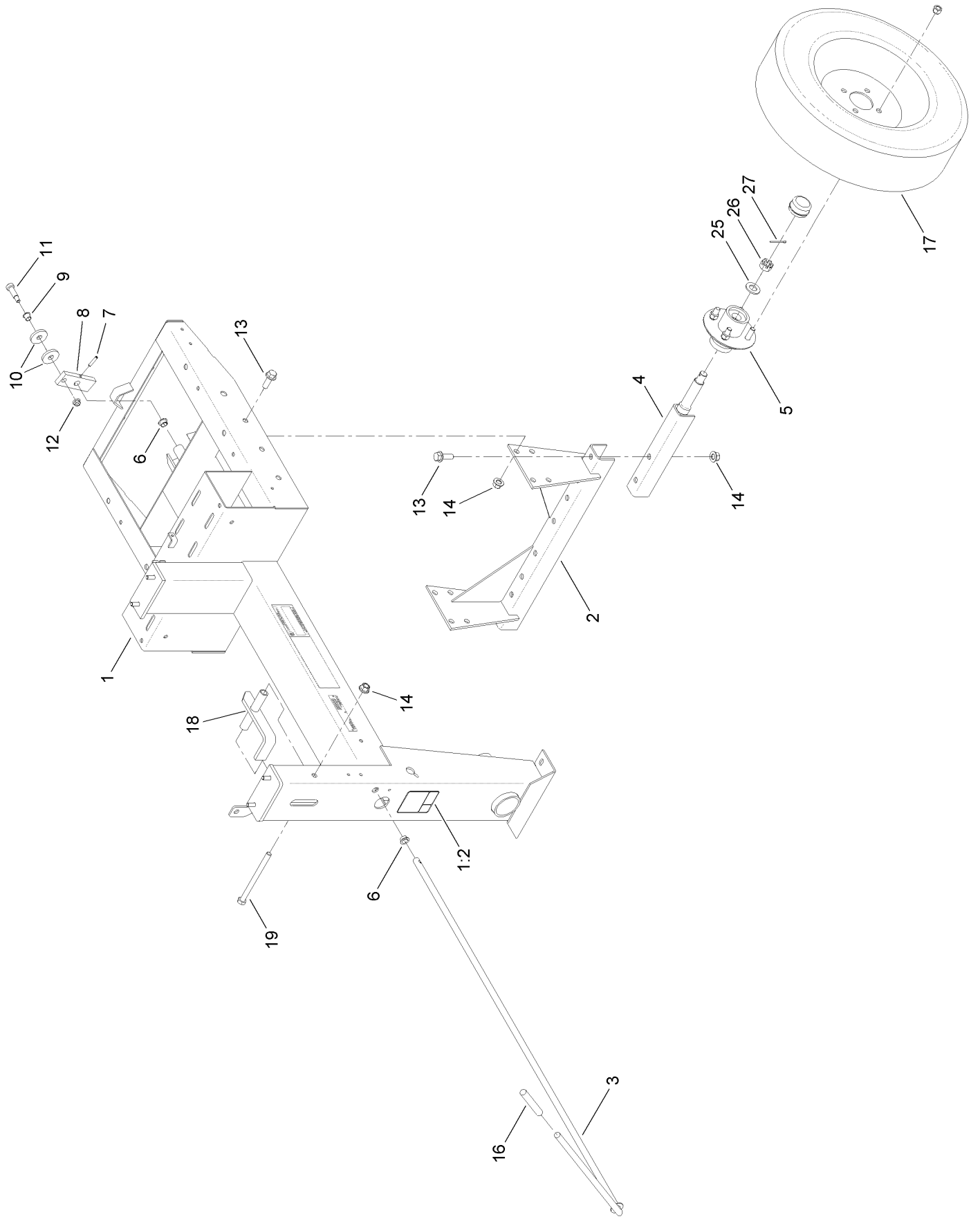

Frame and Axle Assembly (continued)

<i>Ref.</i>	<i>Part Number</i>	<i>Qty.</i>	<i>Description</i>	<i>Ref.</i>	<i>Part Number</i>	<i>Qty.</i>	<i>Description</i>
1	127-1680	1	Frame ASM	11	ST81153	1	Screw-HSBH
1:2	125-8216	1	Decal-Safety Chain, Towing	12	104-8301	1	Nut-Flange, NI
2	125-8219-03	1	Support-Axle	13	100-6116	8	Screw-HHF
3	ST39568-03	1	Lever-Clutch	14	99-5107	9	Nut-Lock
4	ST22512-03	2	Axle-Half	16	ST34687	1	Grip-Handle
5	125-8171	2	Hub ASM	17	ST32306	2	Tire And Rim ASM
6	ST32116	2	Bushing-Flange	18	ST24027-03	1	Latch-Drum
7	32121-69	1	Pin-Spring	19	325-33	1	Screw-HH
8	ST39446	1	Link-Clutch	25	3256-28	2	Washer-Flat
9	ST32099	1	Bushing-Flange	26	ST80054	2	Nut
10	ST26326	2	Washer-Flat	27	3272-13	2	Pin-Cotter

Hub Assembly No. 125-8171

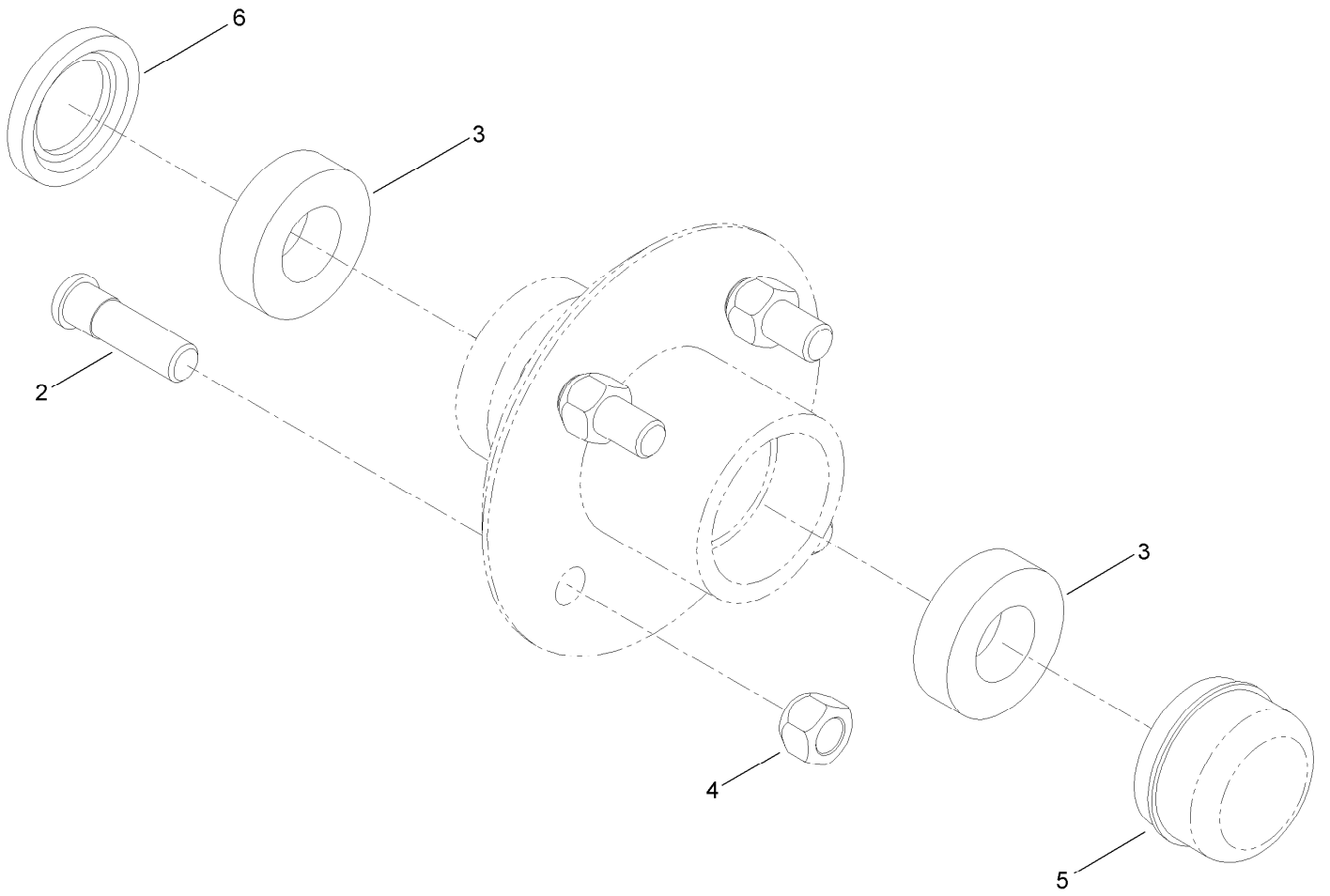

Hub Assembly No. 125-8171 (continued)

<i>Ref.</i>	<i>Part Number</i>	<i>Qty.</i>	<i>Description</i>
2	ST39190	4	Stud-Wheel
3	ST32233	2	Bearing-Roller
4	ST80045	4	Nut-Lug

<i>Ref.</i>	<i>Part Number</i>	<i>Qty.</i>	<i>Description</i>
5	ST34573	1	Cap-Dust
6	ST32052	1	Seal-Hub, Wheel

Drum Assembly

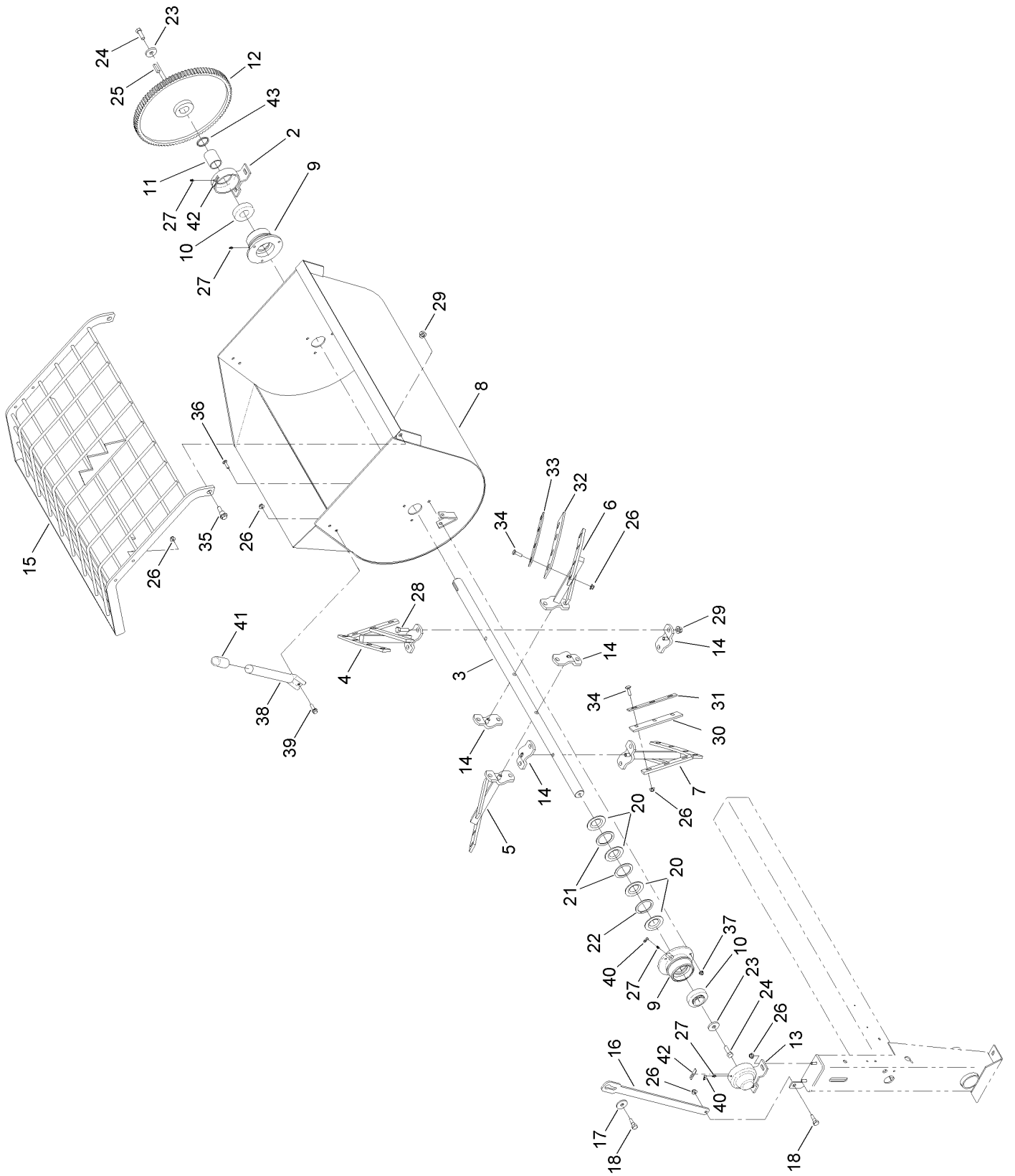

Drum Assembly (continued)

<i>Ref.</i>	<i>Part Number</i>	<i>Qty.</i>	<i>Description</i>	<i>Ref.</i>	<i>Part Number</i>	<i>Qty.</i>	<i>Description</i>
2	ST24021-01	1	Trunnion	24	325-6	2	Screw-HH
3	ST24205-01	1	Shaft-Drum	25	ST81060	1	Key-Square
4	ST24219-01	1	Paddle	26	104-8301	30	Nut-Flange, NI
5	ST24220-01	1	Paddle	27	ST46042	4	Fitting-Grease
6	ST24221-01	1	Paddle	28	325-7	6	Screw-HH
7	ST24222-01	1	Paddle	29	99-5107	8	Nut-Lock
8	ST25934-01	1	Drum	30	ST24033	2	Blade-Rubber, Short
9	ST32326-01	2	Housing-Bearing	31	ST24031-01	2	Bar-Backer, Short
10	ST32003	2	Bearing-Ball	32	ST24106	4	Blade-Rubber, Long
11	ST25909	1	Spacer-Shaft, Drum	33	ST24104-01	4	Bar-Backer, Long
12	ST26933-03	1	Gear-94 Teeth	34	3231-25	22	Bolt-CARR
13	ST36574-01	1	Trunnion-Capped	35	116-0780	2	Screw-HHF, Shoulder
14	ST24107-01	2	Clamp	36	3230-3	6	Screw-CARR
15	125-6253-01	1	Guard-Drum	37	104-8300	6	Nut-Flange, NI
16	125-6223-03	1	Bar-Guard, Lift	38	ST44347-01	1	Handle-Dump
17	106-2008	1	Washer-Thrust	39	3234-24	2	Screw-HHF
18	80-1300	2	Bolt-Shoulder	40	ST47001	4	Cap-Plug
20	ST32324	8	Seal-Drum	41	ST47023	1	Grip-Hand
21	ST24017	4	Washer-Flat	42	125-8175	2	Decal-Grease
22	ST25881	2	Washer-Split	43	ST44284	1	Spacer-Shaft, Drum
23	ST26326	2	Washer-Flat				

Electric Motor Assembly

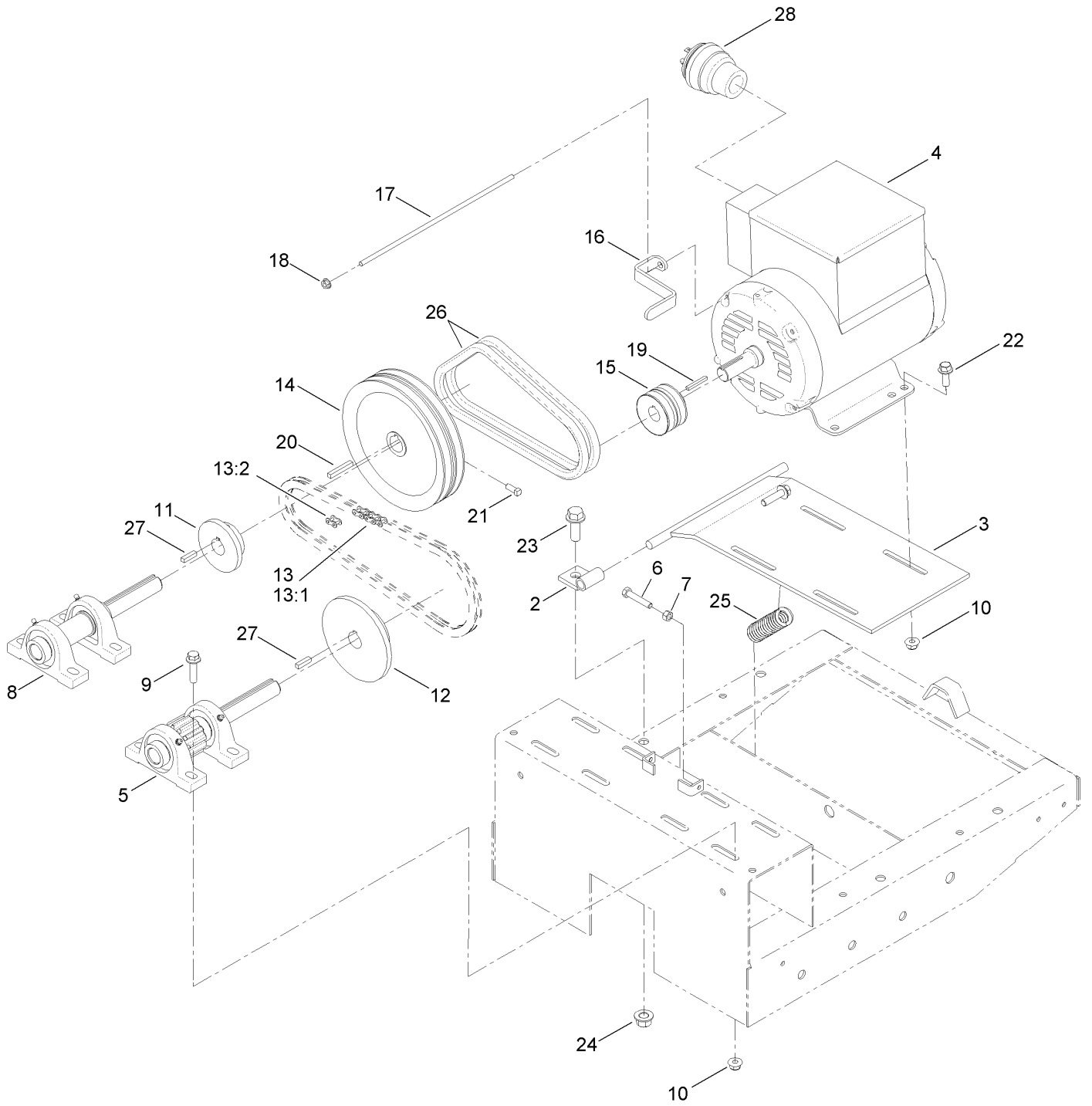

Electric Motor Assembly (continued)

<i>Ref.</i>	<i>Part Number</i>	<i>Qty.</i>	<i>Description</i>	<i>Ref.</i>	<i>Part Number</i>	<i>Qty.</i>	<i>Description</i>
2	ST57786-03	2	Mount-Motor	15	ST38666	1	Sheave
3	ST39567-03	1	Base-Motor	16	ST42446-03	1	Guide-Belt
4	125-6254	1	Motor-Electric	17	127-2887	1	Rod-Threaded
5	ST32354	1	Pinion ASM	18	32128-14	1	Nut-HF
6	322-41	2	Screw-HH	19	ST37716	1	Key-Square
7	3217-6	2	Nut-Hex	20	7-0238	1	Key-Square
8	ST21300	1	Idler ASM	21	120-6474	2	Screw-Set, SQH
9	114-4681	8	Screw-HHF	22	3234-42	4	Screw-HHF
10	104-8301	12	Nut-Flange, NI	23	100-6116	2	Screw-HHF
11	ST34126	1	Sprocket	24	99-5107	2	Nut-Lock
12	ST34127	1	Sprocket	25	ST34849	1	Spring
13	ST21184	1	Chain Set	26	ST34617	2	Belt-V
13:1	ST34102	3	Chain	27	5-7280	2	Key
13:2	ST34104	1	Link-Connecting, No. 50	28	127-1678	1	Plug
14	ST38450	1	Sheave				

Pinion Assembly No. ST32354

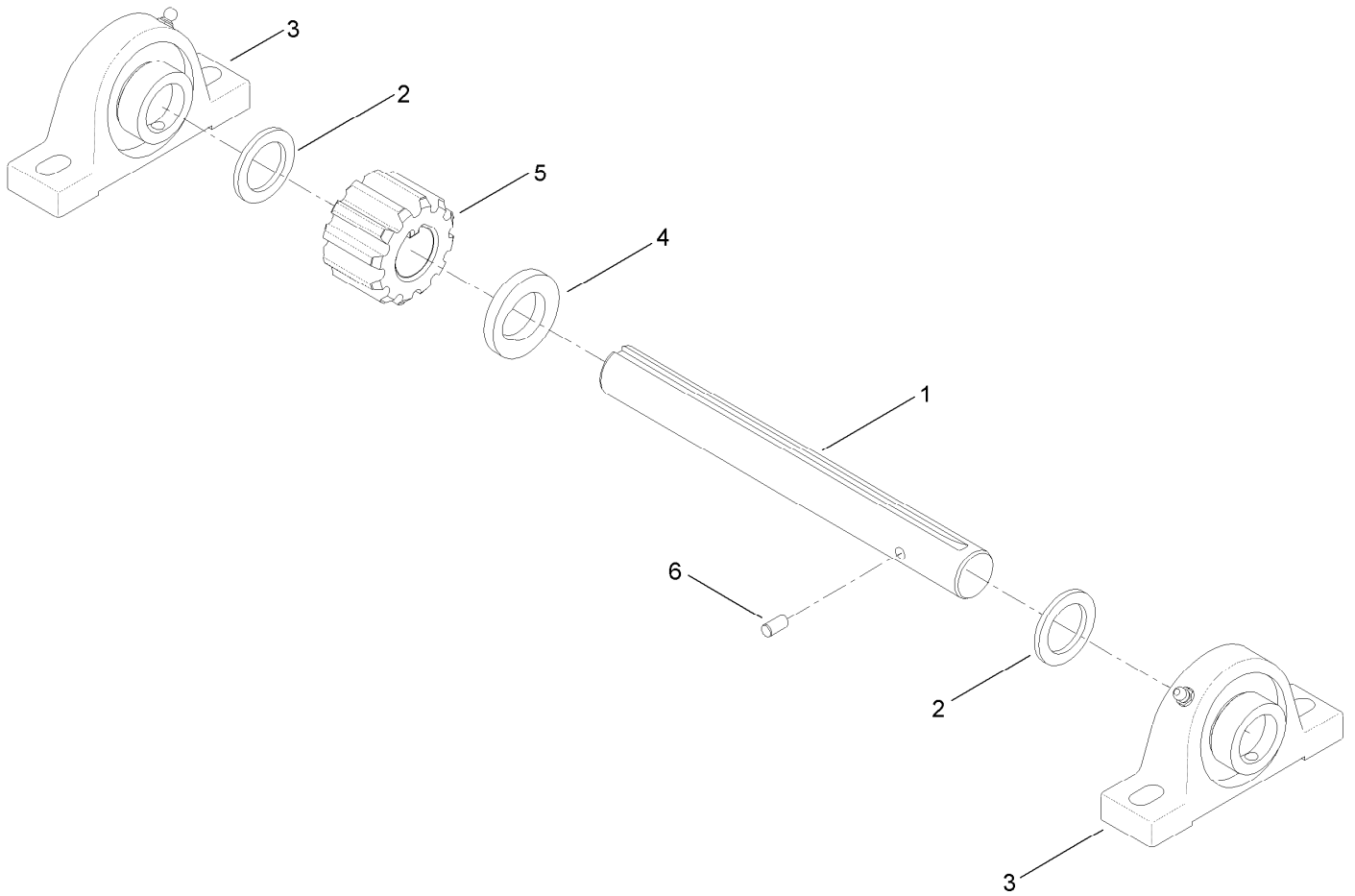

Pinion Assembly No. ST32354 (continued)

<i>Ref.</i>	<i>Part Number</i>	<i>Qty.</i>	<i>Description</i>
1	ST24036	1	Shaft-Pinion
2	3-8514	2	Washer-Thrust
3	ST32208	2	Bearing-Block, Pillow

<i>Ref.</i>	<i>Part Number</i>	<i>Qty.</i>	<i>Description</i>
4	ST38122	1	Washer
5	ST57625	1	Gear-Spur
6	95-0715	1	Pin-Dowel

Idler Assembly No. ST21300

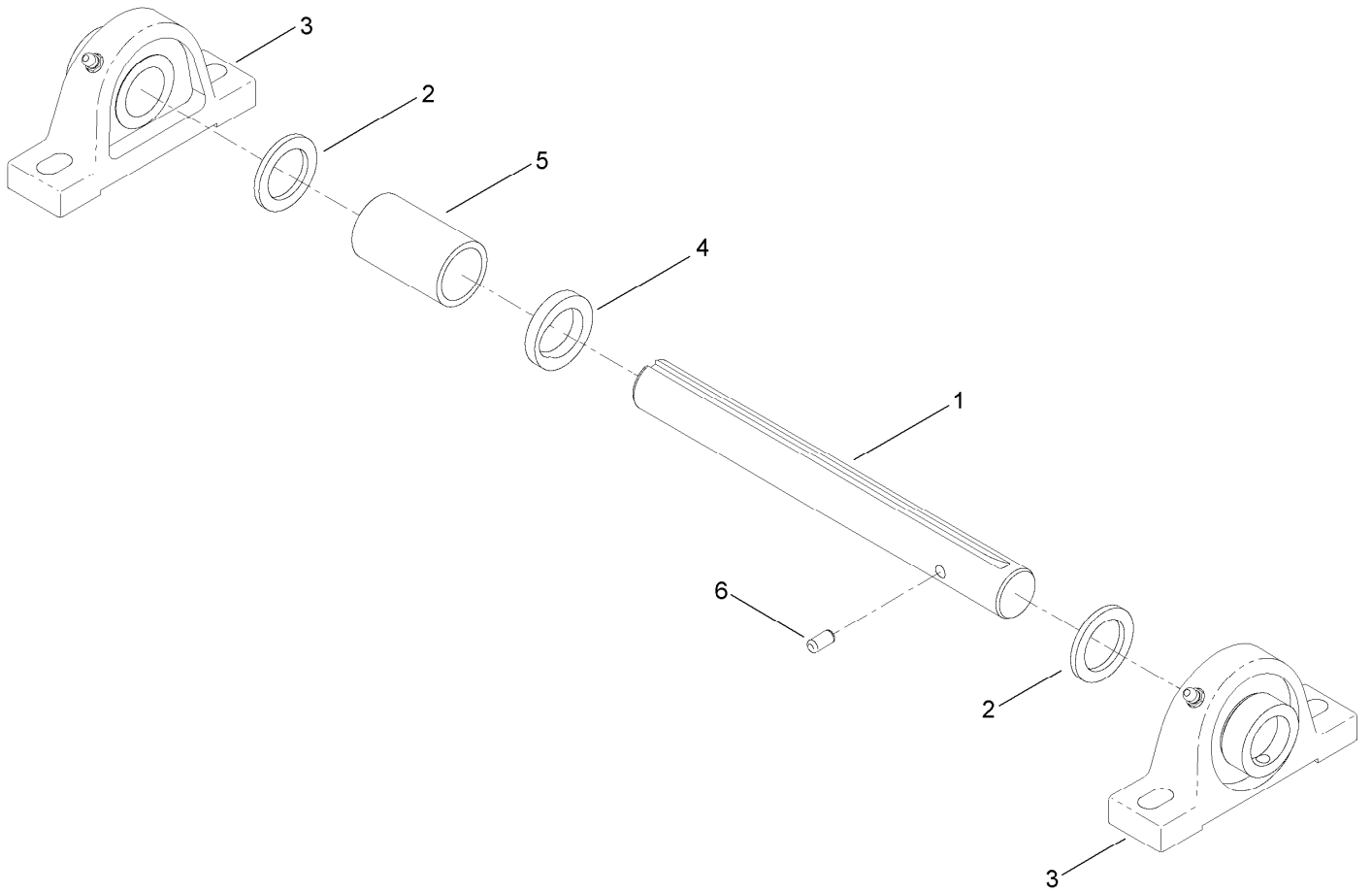

Idler Assembly No. ST21300 (continued)

<i>Ref.</i>	<i>Part Number</i>	<i>Qty.</i>	<i>Description</i>
1	ST24036	1	Shaft-Pinion
2	3-8514	2	Washer-Thrust
3	ST32208	2	Bearing-Block, Pillow

<i>Ref.</i>	<i>Part Number</i>	<i>Qty.</i>	<i>Description</i>
4	ST38122	1	Washer
5	ST42966-03	1	Spacer-Idler
6	95-0715	1	Pin-Dowel

Cowl Assembly

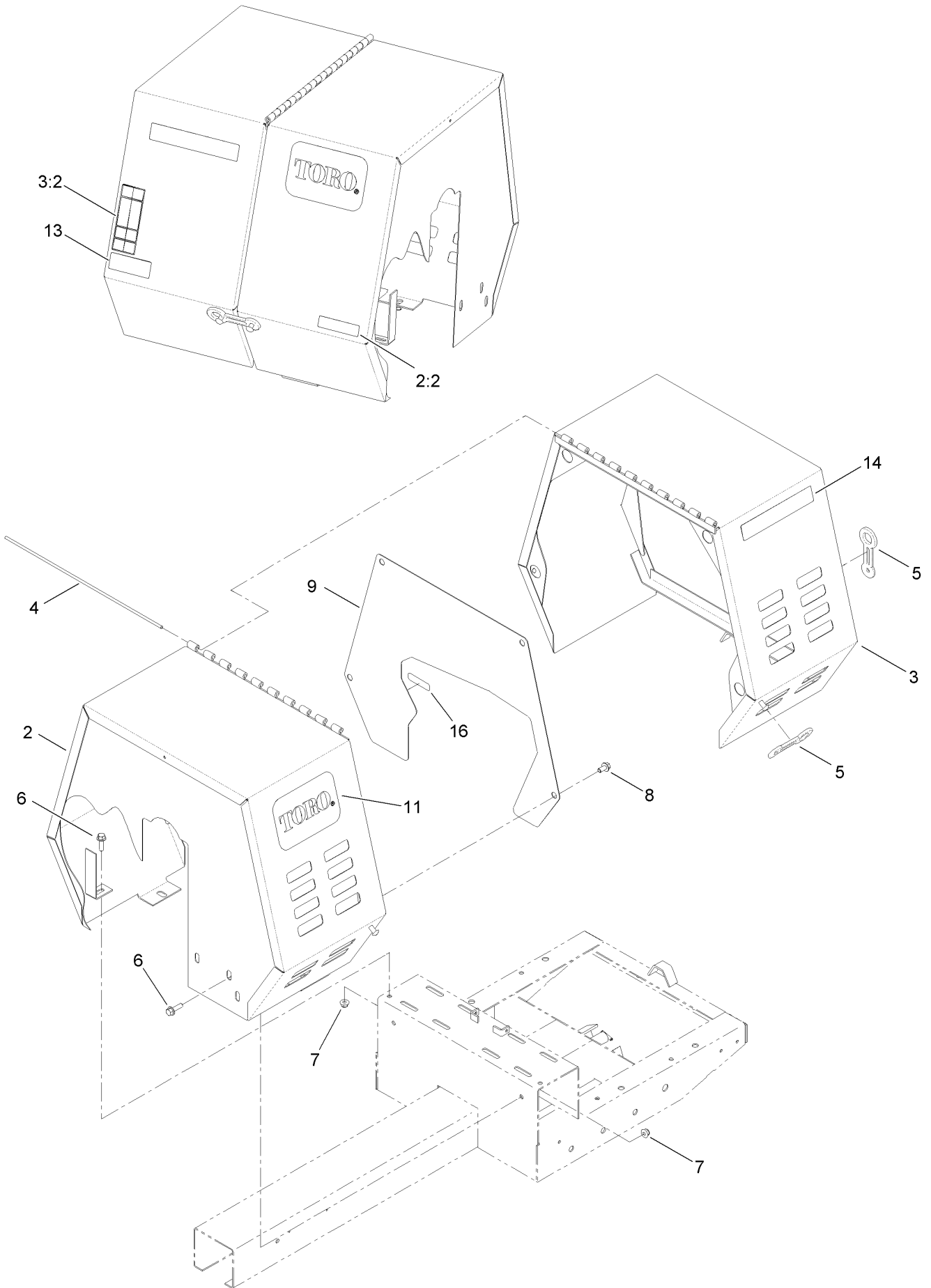

Cowl Assembly (continued)

<i>Ref.</i>	<i>Part Number</i>	<i>Qty.</i>	<i>Description</i>	<i>Ref.</i>	<i>Part Number</i>	<i>Qty.</i>	<i>Description</i>
2	127-1683	1	Stationary Cowl ASM	7	104-8301	6	Nut-Flange, NI
2:2	117-2718	1	Decal-Arrester, Spark	8	110-9380	4	Screw-HWH
3	127-1687	1	Movable Cowl ASM	9	125-8166-03	1	Plate-Belt Guard
3:2	127-1652	1	Decal-Warning, Electric Mixer	11	67-7320	2	Decal
4	ST44368	1	Pin	13	125-4942	1	Decal
5	ST47182	3	Latch-Rubber	14	125-4947	2	Decal-Mm-650E
6	3234-24	6	Screw-HHF	16	125-8175	1	Decal-Grease

Attachments and Accessories

For 68012 MM-650E-S Mortar Mixer

Product Name	Model/Part
31 inch Forged Tow Pole Hitch	68056
31 inch Pintel Tow Pole Hitch	68058
31 inch Stamped Tow Pole Hitch	68060
Trailer Light Kit.....	68062

Notes:



Count on it.