



Count on it.

Parts Catalog

MM-658H-P Mortar Mixer

Model No. 68017—Serial No. 314000001 and Up



Ordering Replacement Parts

To order replacement parts, please supply the part number, the quantity, and the description of each part desired.

Understanding Reference Numbers

Each identified part in an illustration has a reference number. The reference number for a part also appears in the parts list, along with other information about the part.

This catalog uses two special reference number formats, one to indicate parts in a service assembly and another to indicate the quantity of a given part in an illustration.

Service Assembly Reference Numbers

Parts in service assemblies have reference numbers in the form a:b. The a represents the reference number of the entire service assembly and the b represents a sequential number unique to each part within the service assembly.

For example, a wheel assembly might be identified by reference number 6, the tire by 6:1, the valve by 6:2, and the wheel by 6:3. When you order the assembly identified by reference number 6, you receive all parts identified by reference numbers 6:1, 6:2, and 6:3. However, you may also order any part individually. Reference numbers of this type appear in illustration and in parts lists.

Reference Numbers Indicating Quantity

In an illustration, if a reference number indicates more than one part, the reference number has the form nX y. The n represents the quantity of the part, the X is the multiplication symbol, and the y represents the reference number.

For example, in an illustration, the reference number 2X 37 means that two of the parts identified by reference number 37 are indicated.

List of Abbreviations

AR: as required

ASM: assembly

BBC: blade brake control

BHTF: button head thread forming

CARR: carriage

CCW: counter clockwise

CW: clockwise

DEG: degrees

DPA: Dual Point Adjustment

ECM: electronic control module

EXT: external

FH: flat head

GA: gauge

HD: heavy-duty

HF: hex flange

HH: hex head

HHF: hex head flange

HHFTF: hex head flange thread forming

HJ: hex jam

HLH: hex lag head

HOC: height-of-cut

HP: high pressure

HSBH: hex socket button head

HSFH: hex socket flat head

HSH: hex socket head

HWH: hex washer head

HWHTF: hex washer head thread forming

HYD: hydraulic

LH: left hand

LP: low pressure

LPG: Liquefied Petroleum Gas

NI: nylon insert

NPTF: national pipe thread fine

PFH: phillips flat head

PPH: phillips pan head

PPHTF: phillips pan head thread forming

PRH: phillips round head

PTH: phillips truss head

PTO: power-take-off

RH: right hand

ROPS: roll-over protection system

RRB: rear roller brush

SFH: slotted fillister head

SHH: slotted hex head

SHWH: slotted hex washer head

SPH: slotted pan head

SQH: square head

SRH: slotted round head

STD: standard

TAP: self tapping

TTH: torx truss head

Contents

Frame and Axle Assembly	4
Hub Assembly No. 125-8171	6
Drum Assembly	8
Engine and Pinion Assembly	10
Pinion Assembly No. 131-5704	12
Cowl Assembly	14
Attachments and Accessories	16

Frame and Axle Assembly

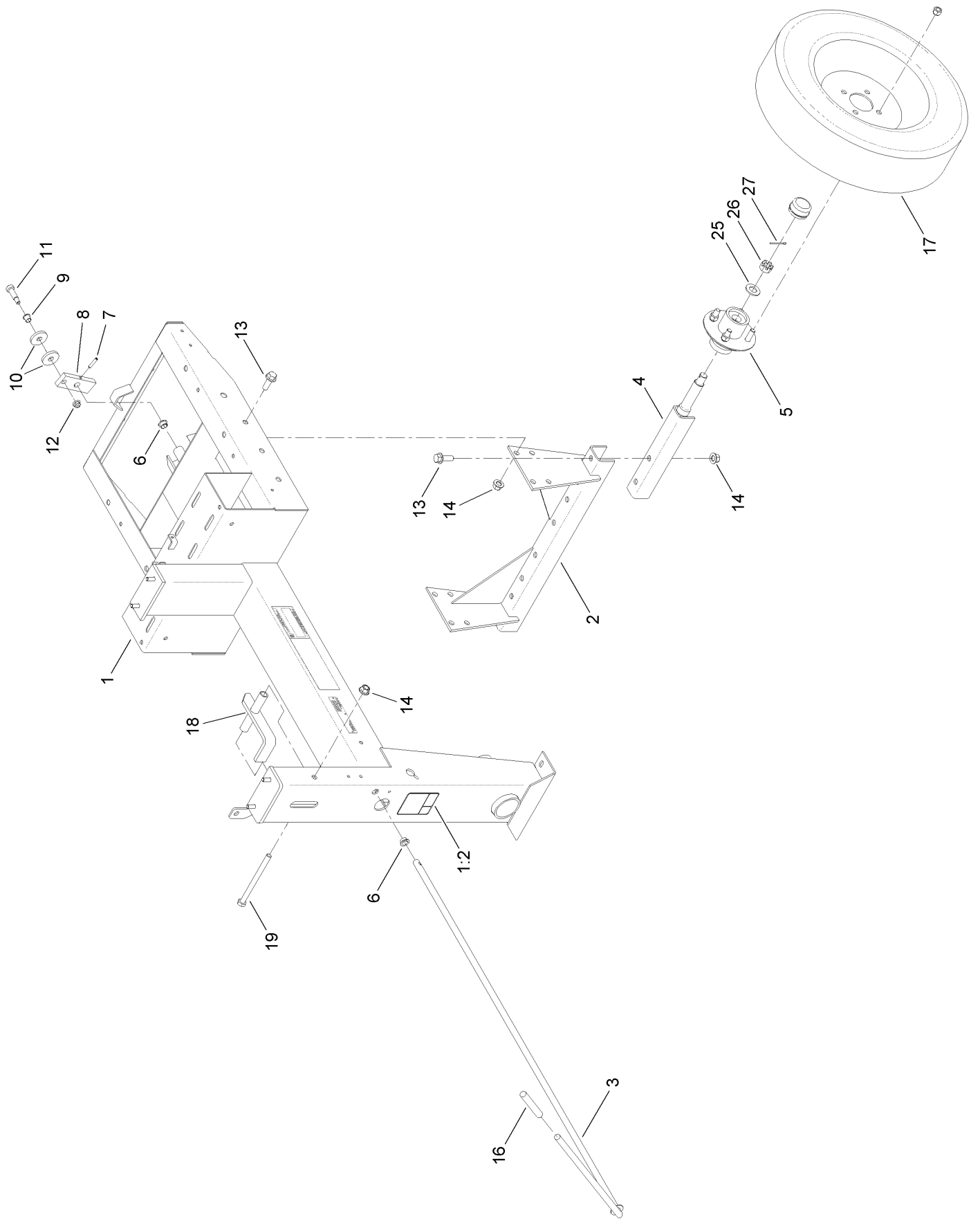

Frame and Axle Assembly (continued)

<i>Ref.</i>	<i>Part Number</i>	<i>Qty.</i>	<i>Description</i>	<i>Ref.</i>	<i>Part Number</i>	<i>Qty.</i>	<i>Description</i>
1	127-1680	1	Frame ASM	11	ST81153	1	Screw-HSBH
1:2	125-8216	1	Decal-Safety Chain, Towing	12	104-8301	1	Nut-Flange, NI
2	125-8219-03	1	Support-Axle	13	100-6116	8	Screw-HHF
3	ST39568-03	1	Lever-Clutch	14	99-5107	9	Nut-Lock
4	ST22512-03	2	Axle-Half	16	ST34687	1	Grip-Handle
5	125-8171	2	Hub ASM	17	ST32306	2	Tire And Rim ASM
6	ST32116	2	Bushing-Flange	18	ST24027-03	1	Latch-Drum
7	32121-69	1	Pin-Spring	19	325-33	1	Screw-HH
8	ST39446	1	Link-Clutch	25	3256-28	2	Washer-Flat
9	ST32099	1	Bushing-Flange	26	ST80054	2	Nut
10	ST26326	2	Washer-Flat	27	3272-13	2	Pin-Cotter

Hub Assembly No. 125-8171

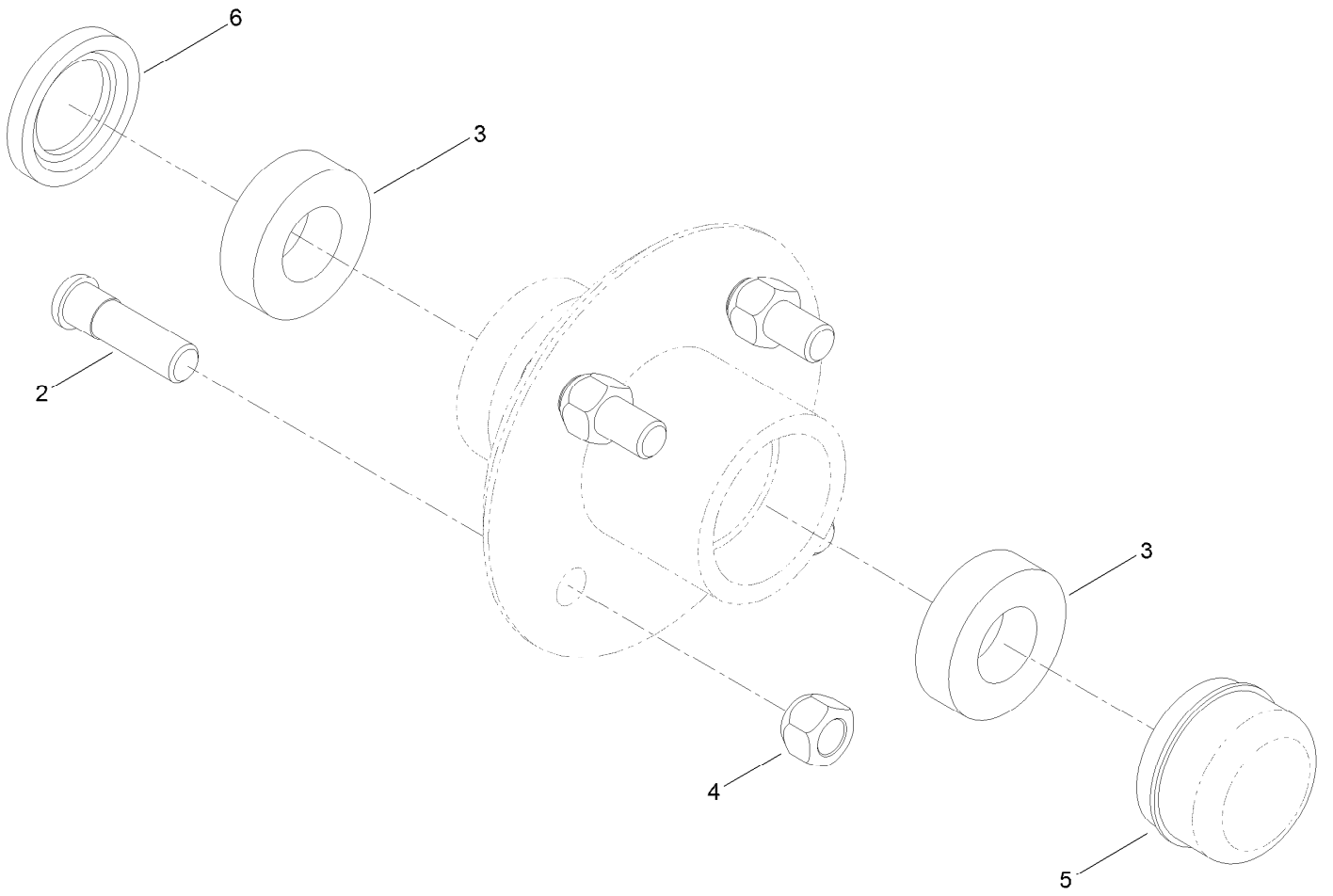

Hub Assembly No. 125-8171 (continued)

<i>Ref.</i>	<i>Part Number</i>	<i>Qty.</i>	<i>Description</i>
2	ST39190	4	Stud-Wheel
3	ST32233	2	Bearing-Roller
4	ST80045	4	Nut-Lug

<i>Ref.</i>	<i>Part Number</i>	<i>Qty.</i>	<i>Description</i>
5	ST34573	1	Cap-Dust
6	ST32052	1	Seal-Hub, Wheel

Drum Assembly

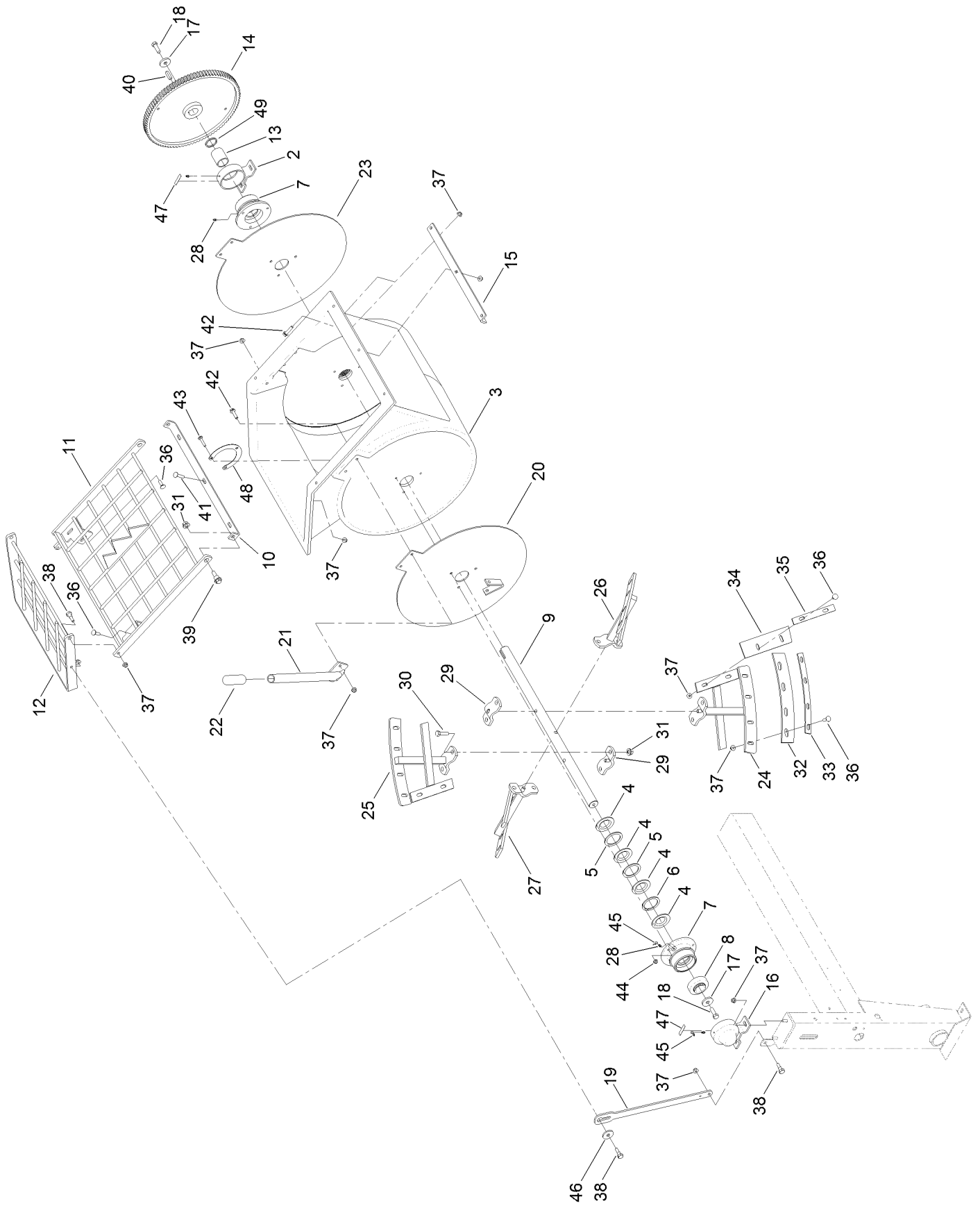

Drum Assembly (continued)

<i>Ref.</i>	<i>Part Number</i>	<i>Qty.</i>	<i>Description</i>	<i>Ref.</i>	<i>Part Number</i>	<i>Qty.</i>	<i>Description</i>
2	ST24021-01	1	Trunnion	26	ST45852-01	1	Paddle
3	127-2876	1	Drum	27	ST45853-01	1	Paddle
4	ST32324	8	Seal-Drum	28	ST46042	4	Fitting-Grease
5	ST24017	4	Washer-Flat	29	ST24107-01	2	Clamp
6	ST25881	2	Washer-Split	30	325-7	6	Screw-HH
7	ST32326-01	2	Housing-Bearing	31	99-5107	8	Nut-Lock
8	ST32003	2	Bearing-Ball	32	ST24106	4	Blade-Rubber, Long
9	ST45844-01	1	Shaft-Drum	33	ST24104-01	4	Bar-Backer, Long
10	ST45838-01	1	Bracket-Guard, Mount	34	ST47331	2	Blade-Rubber, Short
11	125-6288-01	1	Guard-Drum	35	ST42707-01	2	Bar-Backer, Side
12	125-6289-01	1	Guard-Moveable	36	3231-25	24	Bolt-CARR
13	ST25909	1	Spacer-Shaft, Drum	37	104-8301	43	Nut-Flange, NI
14	ST26933-03	1	Gear-94 Teeth	38	80-1300	4	Bolt-Shoulder
15	ST45856-01	1	Bracket-Support, Guard	39	116-0780	2	Screw-HHF, Shoulder
16	ST36574-01	1	Trunnion-Capped	40	ST81060	1	Key-Square
17	ST26326	2	Washer-Flat	41	3231-5	3	Screw-CARR
18	325-6	2	Screw-HH	42	114-4681	8	Screw-HHF
19	125-6290-03	1	Bar-Guard, Lifter	43	3230-5	6	Screw-CARR
20	ST45845-01	1	End-Drum	44	104-8300	6	Nut-Flange, NI
21	ST24406-01	1	Handle	45	ST47001	4	Cap-Plug
22	ST47023	1	Grip-Hand	46	106-2008	1	Washer-Thrust
23	ST45846-01	1	End-Drum	47	125-8175	2	Decal-Grease
24	ST45848-01	1	Paddle	48	127-1666-01	2	Spacer-Bolt
25	ST45849-01	1	Paddle	49	ST44284	1	Spacer-Shaft, Drum

Engine and Pinion Assembly

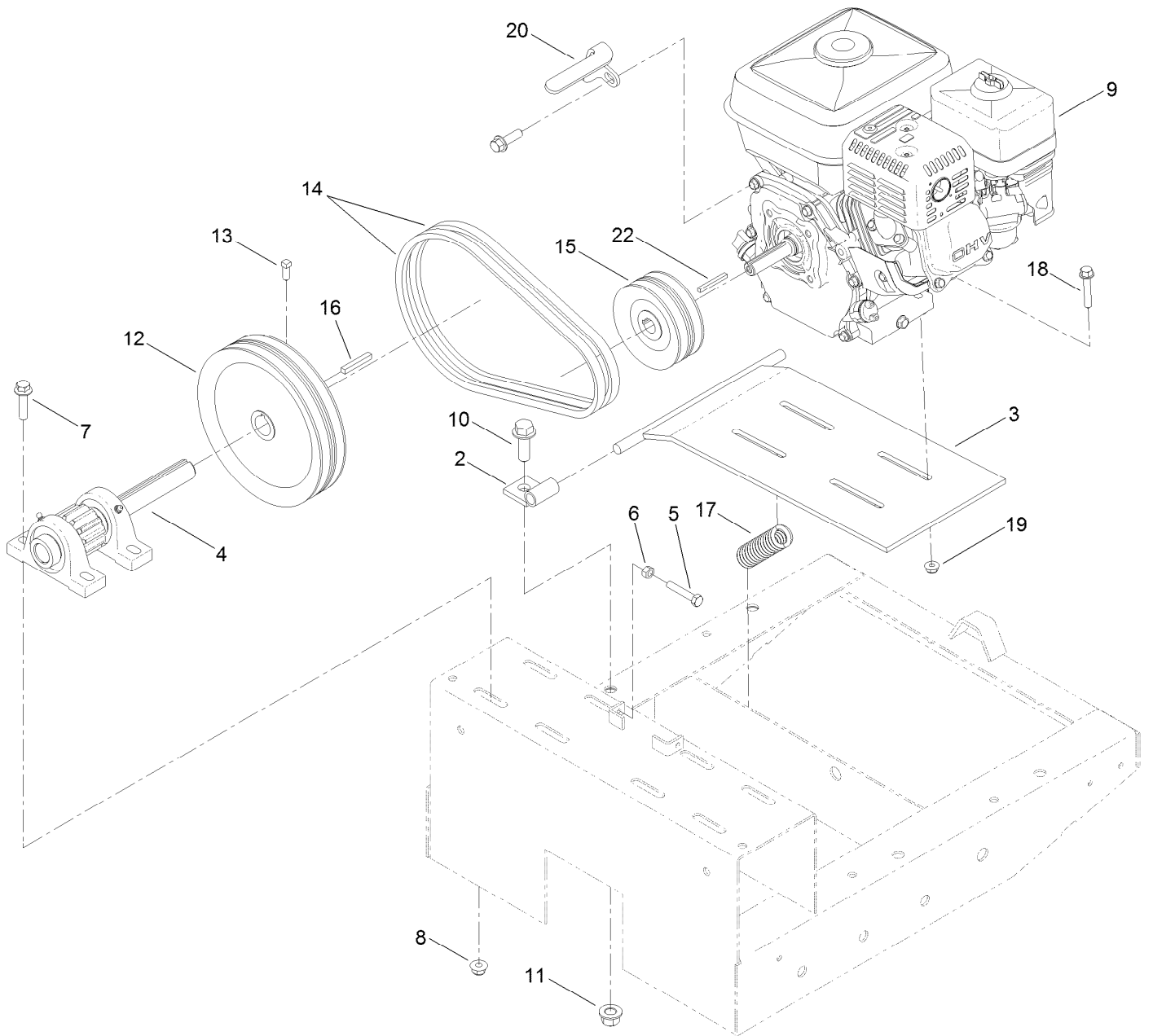

Engine and Pinion Assembly (continued)

<i>Ref.</i>	<i>Part Number</i>	<i>Qty.</i>	<i>Description</i>	<i>Ref.</i>	<i>Part Number</i>	<i>Qty.</i>	<i>Description</i>
2	ST57786-03	2	Mount-Motor	12	ST38450	1	Sheave
3	ST39557-03	1	Base-Motor	13	120-6474	2	Screw-Set, SQH
4	131-5704	1	Pinion ASM	14	ST34052	2	Belt-V
5	322-41	1	Screw-HH	15	ST38449	1	Sheave
6	3217-6	1	Nut-Hex	16	7-0238	1	Key-Square
7	114-4681	4	Screw-HHF	17	ST34849	1	Spring
8	104-8301	4	Nut-Flange, NI	18	114-4681	4	Screw-HHF
9	125-4812	1	Engine-Honda, Gx240 ●	19	104-8301	4	Nut-Flange, NI
10	100-6116	2	Screw-HHF	20	127-1665-03	1	Guide-Belt
11	99-5107	2	Nut-Lock	22	7-0238	1	Key-Square

● Obtain parts from www.honda-engines.com

Pinion Assembly No. 131-5704

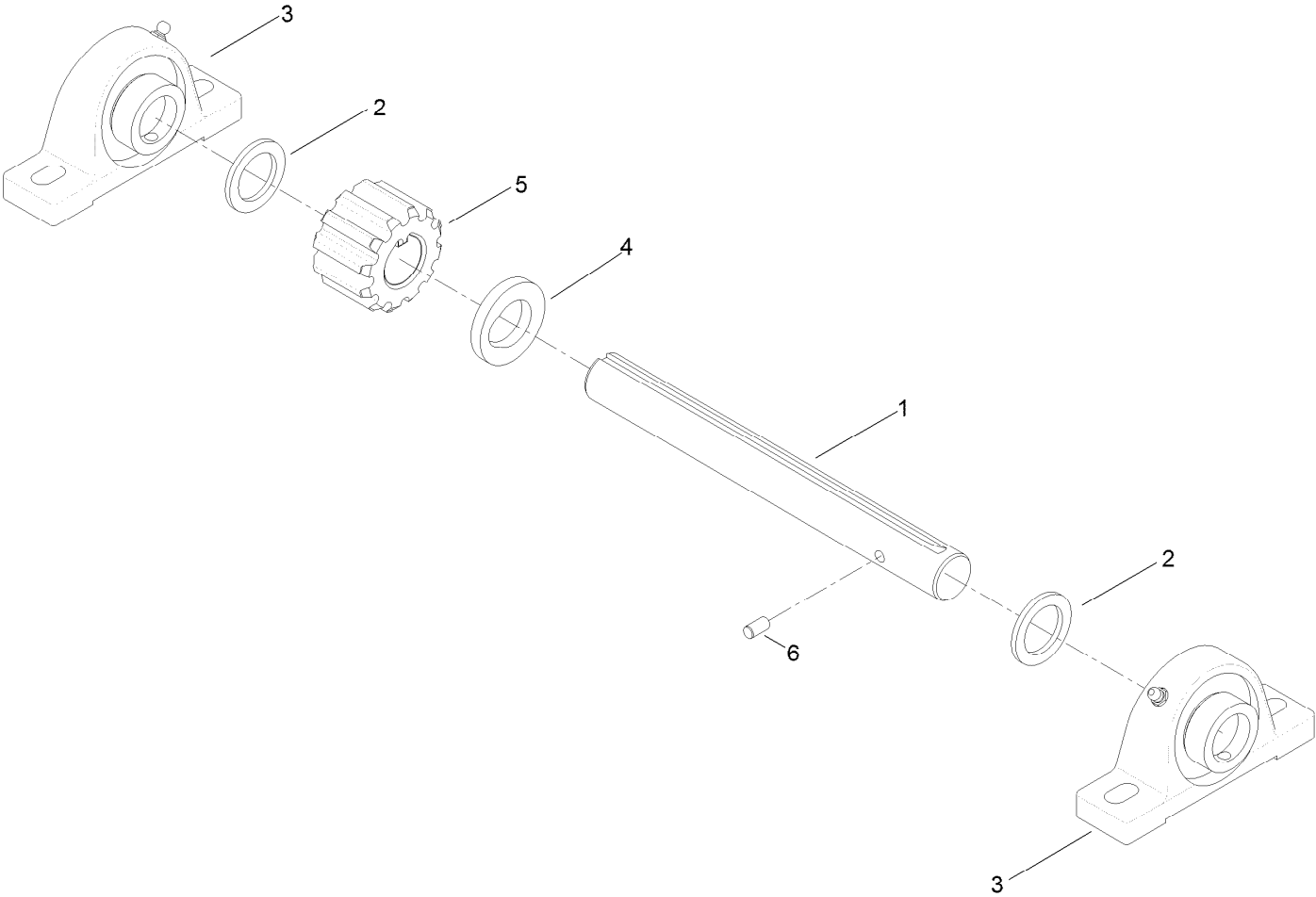

Pinion Assembly No. 131-5704 (continued)

<i>Ref.</i>	<i>Part Number</i>	<i>Qty.</i>	<i>Description</i>
1	131-5705	1	Shaft-Pinion
2	3-8514	2	Washer-Thrust
3	ST32208	2	Bearing-Block, Pillow

<i>Ref.</i>	<i>Part Number</i>	<i>Qty.</i>	<i>Description</i>
4	ST38122	1	Washer
5	ST57625	1	Gear-Spur
6	95-0715	1	Pin-Dowel

Cowl Assembly

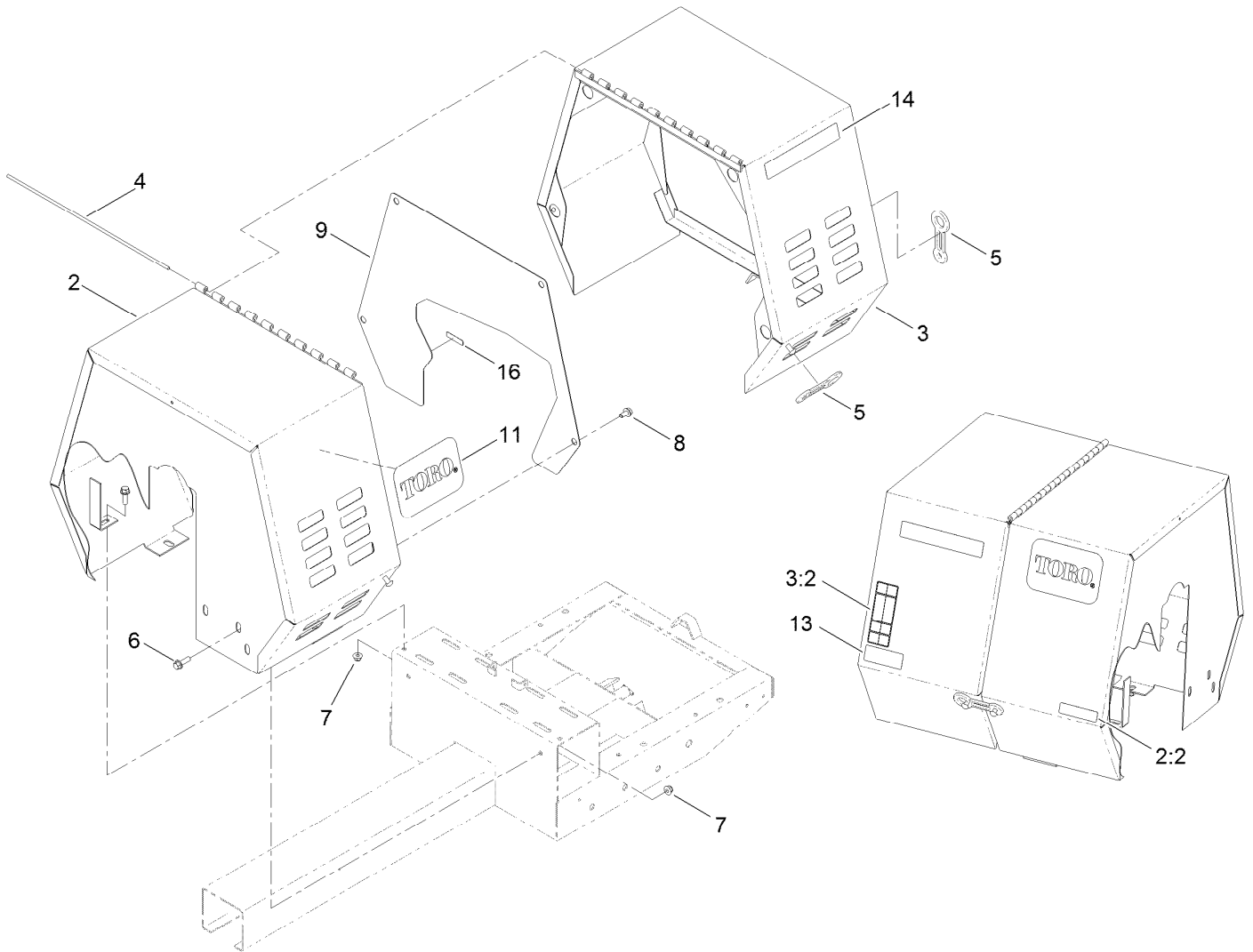

Cowl Assembly (continued)

<i>Ref.</i>	<i>Part Number</i>	<i>Qty.</i>	<i>Description</i>	<i>Ref.</i>	<i>Part Number</i>	<i>Qty.</i>	<i>Description</i>
2	127-1683	1	Stationary Cowl ASM	7	104-8301	6	Nut-Flange, NI
2:2	117-2718	1	Decal-Arrester, Spark	8	110-9380	4	Screw-HWH
3	127-1685	1	Movable Cowl ASM	9	125-6214-03	1	Plate-Access, Belt
3:2	125-4939	1	Decal-Warning	11	67-7320	2	Decal
4	ST44368	1	Pin	13	125-4942	1	Decal
5	ST47182	3	Latch-Rubber	14	125-4949	2	Decal-Mm-658H
6	3234-24	6	Screw-HHF	16	125-8175	1	Decal-Grease

Attachments and Accessories

For 68017 MM-658H-P Mortar Mixer

Product Name	Model/Part
31in Forged Tow Pole Hitch	68056
31in Pintel Tow Pole Hitch	68058
31in Stamped Tow Pole Hitch	68060
Trailer Light Kit.....	68062

Notes:

Notes:

Notes:



Count on it.