



Count on it.

Operator's Manual

PT-Series Power Trowel

Model No. 68048—Serial No. 314000001 and Up

Model No. 68049—Serial No. 314000001 and Up

Model No. 68050—Serial No. 314000001 and Up

Model No. 68051—Serial No. 314000001 and Up

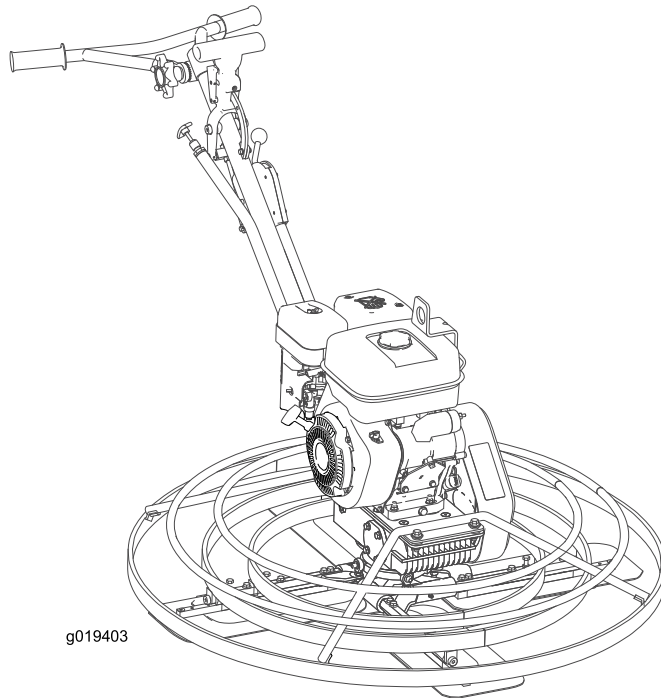

g019403



▲ WARNING

CALIFORNIA Proposition 65 Warning

This product contains a chemical or chemicals known to the State of California to cause cancer, birth defects, or reproductive harm.

The engine exhaust from this product contains chemicals known to the State of California to cause cancer, birth defects, or other reproductive harm.

Use of this product may cause exposure to chemicals known to the State of California to cause cancer, birth defects, or other reproductive harm.

This spark ignition system complies with Canadian ICES-002.

Because in some areas there are local, state, or federal regulations requiring that a spark arrester be used on the engine of this machine, a spark arrester is available as an option. If you require a spark arrester, contact your Authorized Toro Service Dealer.

Genuine Toro spark arresters are approved by the USDA Forestry Service.

Important: It is a violation of California Public Resource Code Section 4442 to use or operate the engine on any forest-covered, brush-covered, or grass-covered land without a spark arrester muffler maintained in working order, or the engine constricted, equipped, and maintained for the prevention of fire. Other states or federal areas may have similar laws.

The enclosed *Engine Owner's Manual* is supplied for information regarding the US Environmental Protection Agency (EPA) and the California Emission Control Regulation of emission systems, maintenance, and warranty. Replacements may be ordered through the engine manufacturer.

Introduction

This machine is used to create a smooth finish to concrete slabs.

Read this information carefully to learn how to operate and maintain your product properly and to avoid injury and product damage. You are responsible for operating the product properly and safely.

You may contact Toro directly at www.Toro.com for product and accessory information, help finding a dealer, or to register your product.

Whenever you need service, genuine Toro parts, or additional information, contact an Authorized Service Dealer or Toro Customer Service and have the model and serial numbers of your product ready. Figure 1 illustrates the location of the model and serial numbers on the product. Write the numbers in the space provided.

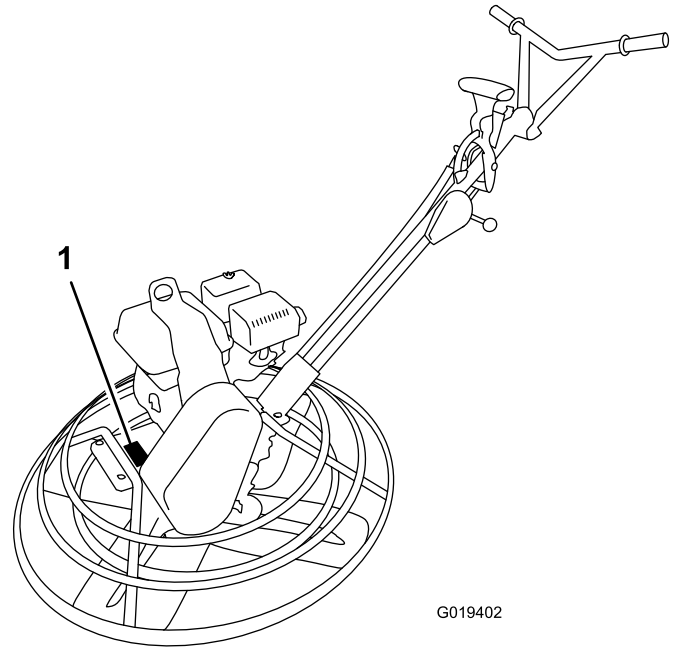

G019402

Figure 1

1. Location of the model and serial numbers

Model No. _____

Serial No. _____

This manual identifies potential hazards and has safety messages identified by the safety alert symbol (Figure 2), which signals a hazard that may cause serious injury or death if you do not follow the recommended precautions.



Figure 2

1. Safety alert symbol

This manual uses 2 words to highlight information.

Important calls attention to special mechanical information and **Note** emphasizes general information worthy of special attention.

Contents

Introduction	2
Safety	4
Safe Operating Practices	4
Safety and Instructional Decals	5
Product Overview	6
Controls	6
Specifications	8
Attachments/Accessories	8
Operation	8
Checking the Engine Oil Level	8
Checking the Gearcase Oil Level	9
Cleaning Debris from the Machine	9
Folding and Unfolding the Handle	9
Adding Fuel	10
Starting and Stopping the Engine	11
Operating the Machine	12
Maintenance	13
Recommended Maintenance Schedule(s)	13
Pre-maintenance Procedures	13
Disconnecting the Spark Plug Wire	13
Lubrication	14
Lubricating the Blade Arms	14
Engine Maintenance	14
Servicing the Air Cleaner	14
Servicing the Engine Oil	15
Servicing the Gearcase Oil	16
Servicing the Spark Plug	17
Belt Maintenance	17
Checking the Belt, Pulley Alignment, Belt Tension, and Belt-guide Gap	17
Removing and Installing the Belt Guard	18
Replacing the Belt	18
Aligning the Pulleys	19
Adjusting the Dyna-Clutch	19
Adjusting the Belt Guide	20
Controls System Maintenance	20
Adjusting the Tilt Knob	20
Adjusting the ProPitch Linkage Rod	21
Testing the Dyna-Clutch Lever	21
Adjusting the Blades	22
Adjusting the Blade Arms	23
Storage	23
Troubleshooting	24

Safety

Improper use or maintenance by the operator or owner can result in injury. To reduce the potential for injury, comply with these safety instructions and always pay attention to the safety alert symbol, which means *Caution*, *Warning*, or *Danger*—personal safety instruction. Failure to comply with the instruction may result in personal injury or death.

Safe Operating Practices

Training

- Read the *Operator's Manual* and other training material. If the operator(s) or mechanic(s) cannot read or understand the information, it is the owner's responsibility to explain this material to them.
- Become familiar with the safe operation of the equipment, operator controls, and safety signs.
- All operators and mechanics should be trained. The owner is responsible for training the users.
- Never let children or untrained people operate or service the equipment. Local regulations may restrict the age of the operator.
- The owner/user can prevent and is responsible for accidents or injuries occurring people, or damage to property.

Preparation

- Wear appropriate clothing including safety glasses and hearing protection. Long hair, loose clothing, or jewelry may get tangled in moving parts.
- Inspect the area where the equipment is to be used and remove all objects which can be contacted by the machine.
- Use extra care when handling gasoline and other fuels. They are flammable and vapors are explosive.
 - Use only an approved container.
 - Never remove the gas cap or add fuel with the engine running.
 - Allow the engine to cool before refueling.
 - Do not smoke.
 - Never fuel or drain the machine indoors.
- Check that the operator presence controls, safety switches, and shields are attached and functioning properly. Do not operate unless they are functioning properly.

Operation

- Only operate in good light, keeping away from holes and hidden hazards.
- Be sure all drives are in neutral before starting engine.
- Never operate without the shields, covers, or other guards securely in place.
- Do not change the engine governor setting or overspeed the engine.
- Stop the equipment and inspect the blades after striking an object or if an abnormal vibration occurs. Make necessary repairs before resuming operation.
- Keep hands and feet away from the blade area.
- Do not operate the machine under the influence of alcohol or drugs.
- Lightning can cause severe injury or death. If lightning is seen or thunder is heard in the area, do not operate the machine; seek shelter.
- Use extreme care when loading or unloading the machine into a trailer or truck.

Maintenance and Storage

- Wait for all movement to stop before adjusting, cleaning, or repairing. Stop the machine, stop the engine, and disconnect the spark-plug wire.
- Clean debris from the blades, drives, muffler, and engine to help prevent fires. Clean up oil or fuel spillage.
- Let the engine cool before storing and do not store near flame.
- Shut off the fuel while storing or transporting on trailers. Do not store fuel near flames or drain indoors.
- Park the machine on level, hard ground. Never allow untrained personnel to service it.
- Keep all parts in good working condition and all hardware tightened. Replace all worn or damaged decals.

Safety and Instructional Decals

Safety decals and instructions are easily visible to the operator and are located near any area of potential danger. Replace any decal that is damaged or lost.

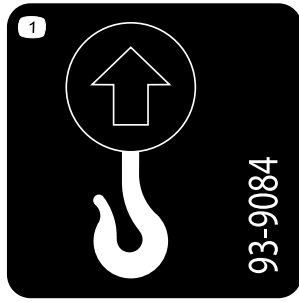

93-9084

1. Lift point
2. Tie-down point

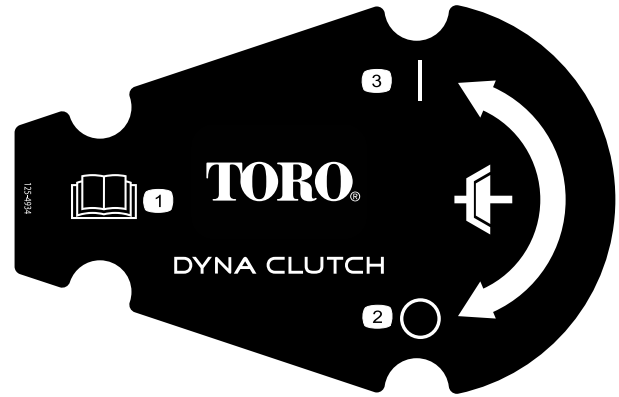

125-4934

1. Read the *Operator's Manual*.
2. Disengage clutch
3. Engage clutch



117-2718

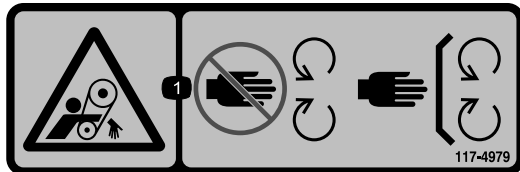

117-4979

1. Entanglement hazard, belt—keep away from moving parts; keep all guards and shields in place

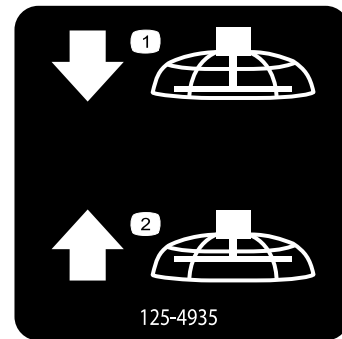

125-4935

Models 68049 and 68051 only

1. Lower the blades
2. Raise the blades

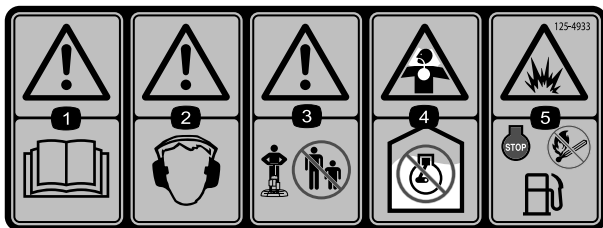

125-4933

1. Warning—read the *Operator's Manual*.
2. Warning—wear hearing protection.
3. Warning—keep bystanders away from the machine.
4. Choking hazard—do not run the engine in an unventilated area.
5. Explosion hazard—stop the engine and extinguish all flames before refueling.

Product Overview

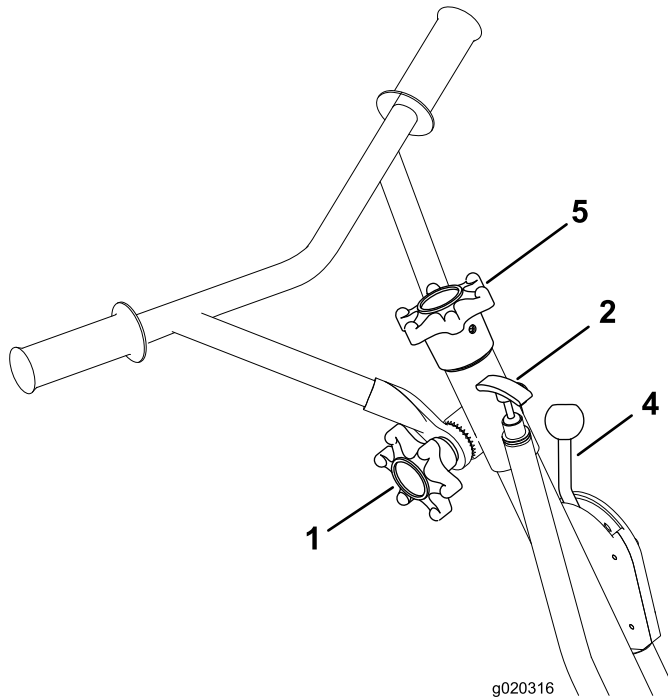
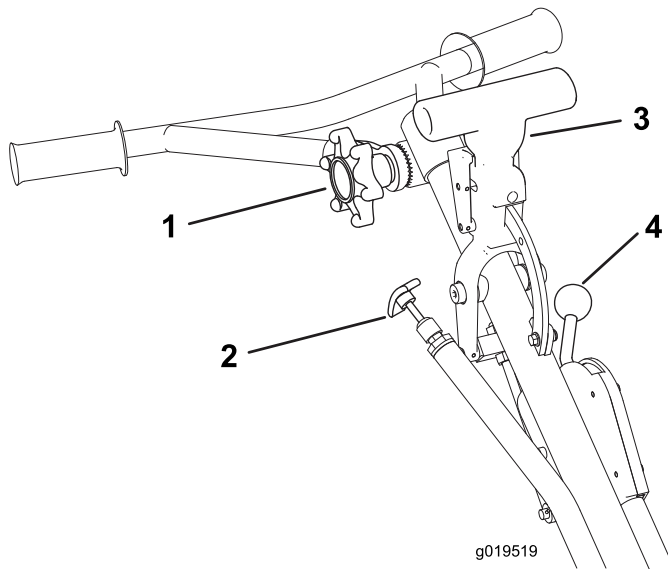

Figure 3

- | | |
|---|---|
| 1. Handle-adjustment knob | 4. Dyna-Clutch lever |
| 2. Throttle handle | 5. Tilt-adjustment knob
(Models 68048 and 68050
only) |
| 3. ProPitch handle (Models
68049 and 68051 only) | |

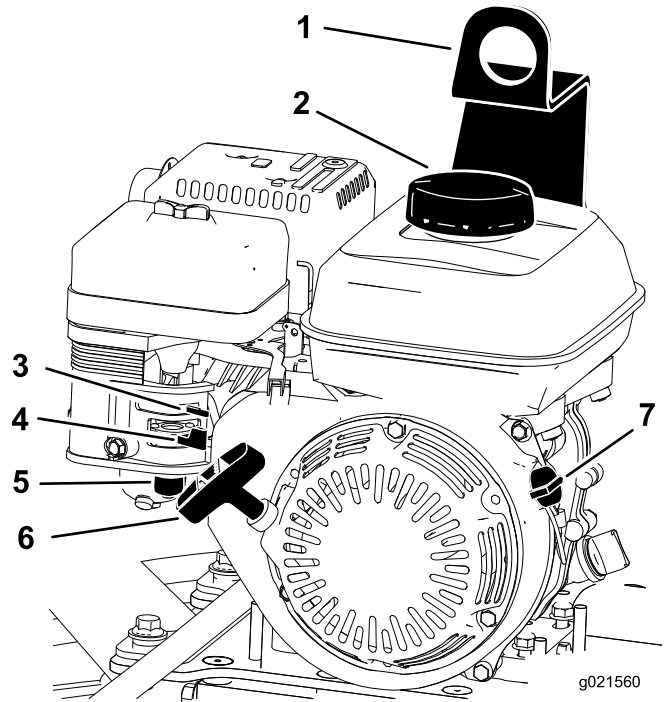

Figure 4

- | | |
|------------------|--------------------------|
| 1. Lifting point | 5. Sediment cup |
| 2. Fuel-tank cap | 6. Recoil-starter handle |
| 3. Choke lever | 7. Engine On/Off switch |
| 4. Fuel valve | |

Controls

Recoil-starter Handle

Pull the recoil-starter handle to start the engine (Figure 4).

Fuel Valve

Close the fuel valve when transporting or storing the machine (Figure 4).

Choke Lever

Use the choke lever (Figure 4) to start a cold engine. Before pulling the recoil-starter handle, move the choke lever to the closed position. Once the engine is running, move the choke lever to the open position.

Note: A warm engine requires little or no choking.

Engine On/Off Switch

The On/Off switch (Figure 4) allows the operator of the machine to start and stop the engine. This switch is located on the front of the engine. Rotate the On/Off switch to the On position to start and run the engine. Rotate the On/Off switch to the Off position to stop the engine.

Throttle Handle

Pull the throttle handle (Figure 3) to increase the engine speed, and push the handle to decrease the engine speed. Turn the handle clockwise to lock the throttle at a specific speed. Turn the handle counterclockwise to unlock the throttle.

Handle-adjustment Knob

Turn the knob counterclockwise to loosen and move the handle to the desired position. Turn the knob clockwise to tighten and lock the handle in place (Figure 3).

Dyna-Clutch Lever

Move the Dyna-Clutch lever (Figure 5) to the On position (up) to allow the blades to rotate. Move the lever to the Off position (down) to stop the blades. In the event that the operator releases the handle while the blades are turning, the centrifugal force from the swing of the handle will throw the clutch lever to the Stop position.

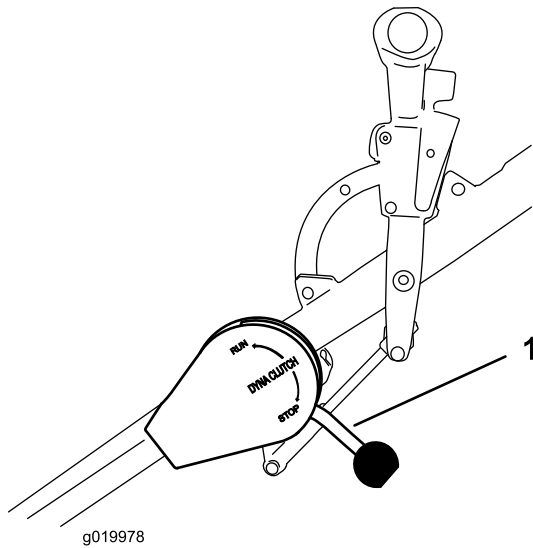

Figure 5

1. Dyna-Clutch lever

ProPitch™ Handle

Models 68049 and 68051 only

Pull the handle to increase the angle of the blades to the concrete. Press the trip button to release the lock, and push the handle to decrease the angle of the blades.

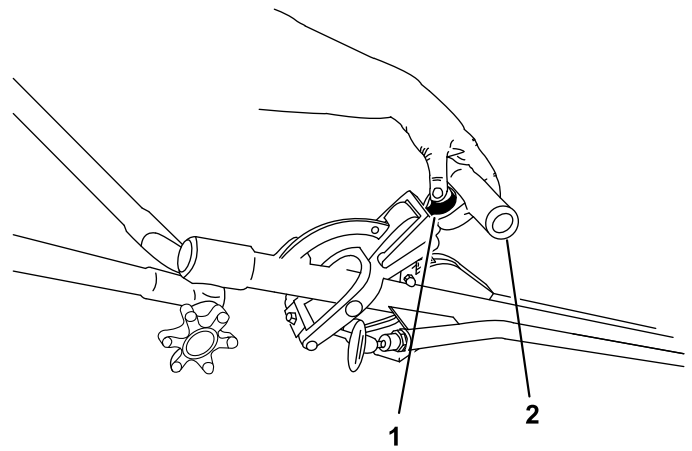

Figure 6

1. Trip button
2. Handle

Tilt-adjustment Knob

Models 68048 and 68050 only

Turn the knob clockwise to increase the angle of the blades (Figure 6). Turn the knob counterclockwise to flatten or decrease the angle of the blades.

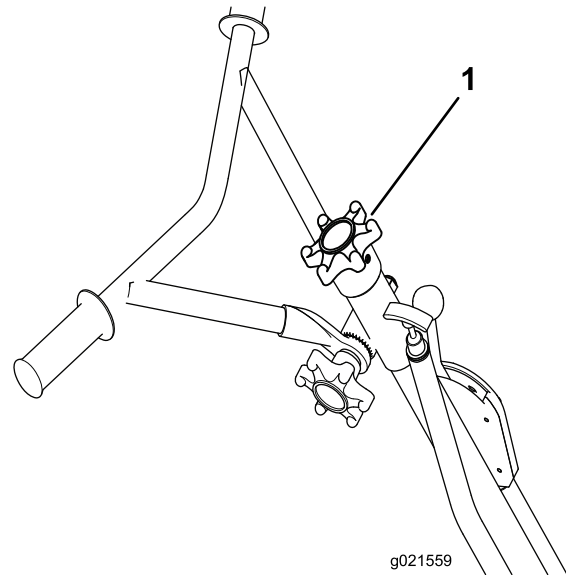

Figure 7

1. Tilt-adjustment knob

Specifications

Note: Specifications and design are subject to change without notice.

Models	68048 and 68049	68050 and 68051
Width	92 cm (36.5 inches)	117 cm (46 inches)
Length (operating)	177 cm (70 inches)	190.5 cm (75 inches)
Height (operating)	99 cm (39 inches)	99 cm (39 inches)
Weight	102 kg (225 lbs)	112 kg (245 lbs)

Attachments/Accessories

A selection of approved attachments and accessories are available for use with the machine to enhance and expand its capabilities. Contact your Authorized Service Dealer or Distributor or go to www.Toro.com for a list of all approved attachments and accessories.

Operation

Note: Determine the left and right sides of the machine from the normal operating position.

Checking the Engine Oil Level

Service Interval: Before each use or daily

The machine comes from the factory with oil in the engine crankcase, however, it may be necessary to add oil. Add only enough oil to raise the level to the Full mark on the dipstick; refer to Servicing the Engine Oil (page 15).

Oil Type: 4-cycle engine oil that meets or exceeds the requirements for API service category **SJ or higher**

Models	Crankcase Capacity
68048 and 68049	0.58 L (0.61 US qt)
68050 and 68051	1.1 L (1.2 US qt)

Important: If the oil level in the crankcase is too low or too high and you run the engine, you may damage the engine.

Note: Use SAE 10W-30 for general use. You can use the other viscosities shown in the chart when the average temperature in your area is within the indicated range (Figure 8).

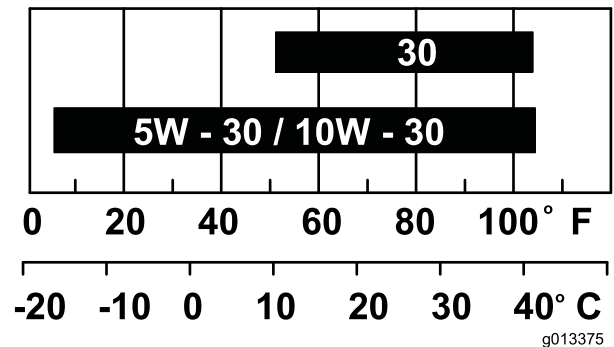

Figure 8

1. Stop the machine on a level surface.
2. Set the Dyna-Clutch lever to the Stop position, stop the engine, wait for all moving parts to stop, and turn off the engine switch.
3. Clean around the dipstick (Figure 9) so that dirt cannot fall into the fill port and damage the engine.

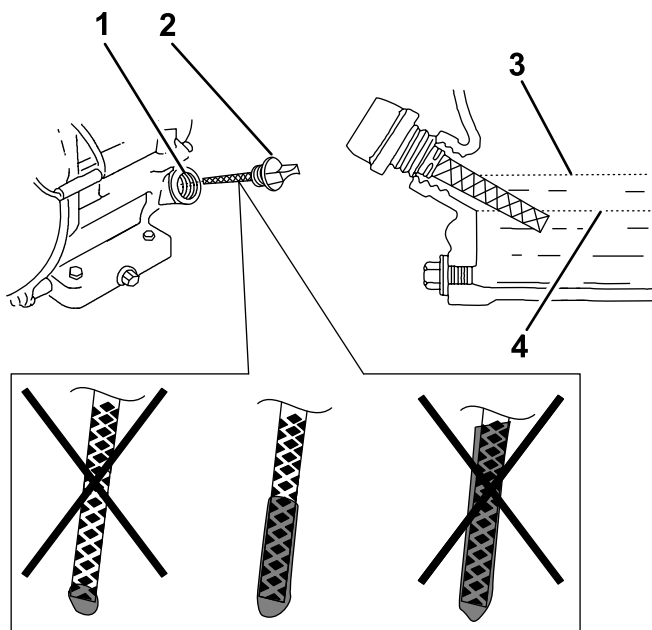

Figure 9

G019746

1. Fill port
2. Dipstick
3. Oil-level upper limit
4. Oil-level lower limit

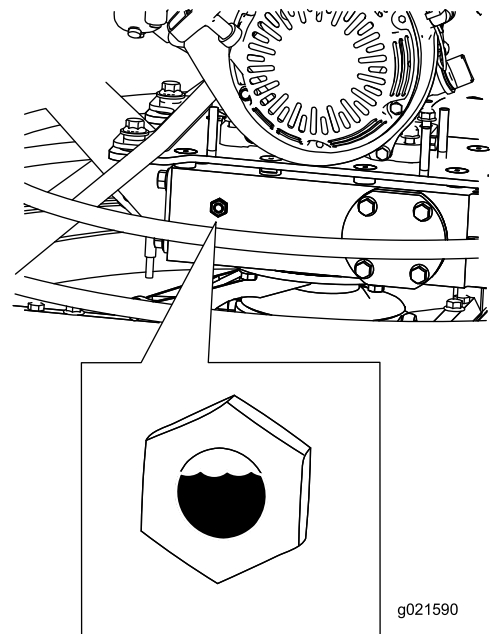

Figure 10

g021590

If the oil level is not correct, refer to Servicing the Gearcase Oil (page 16).

Cleaning Debris from the Machine

Service Interval: Before each use or daily

1. Set the Dyna-Clutch lever to the Stop position, stop the engine, wait for all moving parts to stop, and turn off the engine switch.
2. Brush dirt and debris away from the air cleaner and engine openings.

Checking the Gearcase Oil Level

Service Interval: Before each use or daily

1. Stop the machine on a level surface.
2. Set the Dyna-Clutch lever to the Stop position, stop the engine, and wait for all moving parts to stop.
3. Look at the sight glass in the gearcase plug (Figure 10). The oil level should be 3/4 full.

Folding and Unfolding the Handle

1. Turn the handle-adjustment knob counterclockwise to loosen the handle.
2. Place the handle to the desired position and turn the handle-adjustment knob clockwise to tighten the handle (Figure 11).

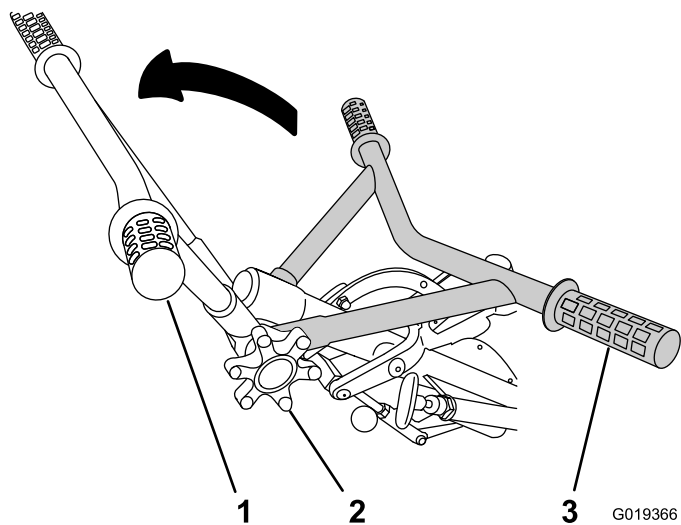

Figure 11

1. Handle fully extended 3. Handle folded
 2. Handle-adjustment knob

Adding Fuel

- For best results, use only clean, fresh (less than 30 days old), unleaded gasoline with an octane rating of 87 or higher ((R+M)/2 rating method).
- **ETHANOL:** Gasoline with up to 10% ethanol (gasohol) or 15% MTBE (methyl tertiary butyl ether) by volume is acceptable. Ethanol and MTBE are not the same. Gasoline with 15% ethanol (E15) by volume is not approved for use. Never use gasoline that contains more than 10% ethanol by volume, such as E15 (contains 15% ethanol), E20 (contains 20% ethanol), or E85 (contains up to 85% ethanol). Using unapproved gasoline may cause performance problems and/or engine damage which may not be covered under warranty.
- **Do not** use gasoline containing methanol.
- **Do not** store fuel either in the fuel tank or fuel containers over the winter unless a fuel stabilizer is used.
- **Do not** add oil to gasoline.

⚠ DANGER

In certain conditions, gasoline is extremely flammable and highly explosive. A fire or explosion from gasoline can burn you and others and can damage property.

- Fill the fuel tank outdoors, in an open area, when the engine is cold. Wipe up any gasoline that spills.
- Never fill the fuel tank inside an enclosed trailer.
- Do not fill the fuel tank completely full. Add gasoline to the fuel tank until the level is 6 to 13 mm (1/4 to 1/2 inch) below the bottom of the filler neck. This empty space in the tank allows gasoline to expand.
- Never smoke when handling gasoline, and stay away from an open flame or where gasoline fumes may be ignited by a spark.
- Store gasoline in an approved container and keep it out of the reach of children. Do not buy more than a 30-day supply of gasoline.
- Do not operate without entire exhaust system in place and in proper working condition.

⚠ DANGER

In certain conditions during fueling, static electricity can be released causing a spark which can ignite the gasoline vapors. A fire or explosion from gasoline can burn you and others and can damage property.

- Always place gasoline containers on the ground away from your vehicle before filling.
- Do not fill gasoline containers inside a vehicle or on a truck or trailer bed because interior carpets or plastic truck bed liners may insulate the container and slow the loss of any static charge.
- When practical, remove gas-powered equipment from the truck or trailer and refuel the equipment with its wheels on the ground.
- If this is not possible, then refuel such equipment on a truck or trailer from a portable container, rather than from a gasoline dispenser nozzle.
- If a gasoline dispenser nozzle must be used, keep the nozzle in contact with the rim of the fuel tank or container opening at all times until fueling is complete.

Using Fuel Stabilizer/Conditioner

Use a fuel stabilizer/conditioner in the machine to keep the fuel fresh during storage of 90 days or less. If you are storing the machine for longer, drain the fuel tank; refer to Storage (page 23).

Important: Do not use fuel additives containing methanol or ethanol.

Add the correct amount of fuel stabilizer/conditioner to the fuel, and follow the directions of the manufacturer.

Note: Fuel stabilizer/conditioner is most effective when mixed with fresh fuel. To minimize the chance of varnish deposits in the fuel system, use fuel stabilizer at all times.

Filling the Fuel Tank

Models	Fuel Tank Capacity
68048 and 68049	3.1 L (0.82 US gallons)
68050 and 68051	5.3 L (1.40 US gallons)

1. Set the Dyna-Clutch lever to the Stop position, stop the engine, wait for all moving parts to stop, and turn off the engine switch.
2. Allow the engine to cool.
3. Clean around the fuel-tank cap and remove it (Figure 12).

Note: The cap is tethered to the fuel tank.

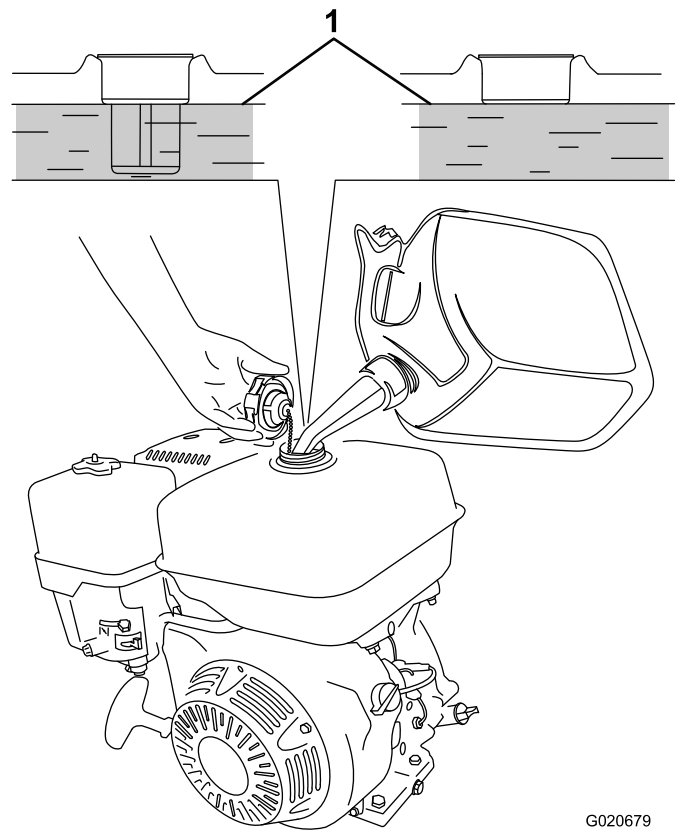

Figure 12

G020679

1. Maximum fuel level

4. Add unleaded gasoline to the fuel tank until the level is at the bottom of the maximum fuel level (Figure 12).

Important: The extra space in the tank allows the fuel to expand. Do not fill the fuel tank completely full.

5. Install the fuel-tank cap securely.
6. Wipe up any fuel that may have spilled.

Starting and Stopping the Engine

Starting the Engine

1. Set the throttle to full rpm and set the Dyna-Clutch lever to the Stop position.
2. Move the engine switch to the On position and turn on the fuel valve.
3. Move the choke lever to the left if you are starting a cold engine.

Note: A warm or hot engine may not require choking.

4. Pull the recoil-start handle slowly until you feel some resistance, then pull it sharply to start the engine.
5. After the engine starts, gradually move the choke to the right. If the engine stalls or hesitates, move the choke left again until the engine warms up.

6. Move the throttle lever to desired setting.

Stopping the Engine

1. Turn the engine switch and fuel valve off.
2. Wait for all moving parts to stop before proceeding.

Operating the Machine

Important: Use the machine on concrete that has not set completely, but ensure that the concrete has set enough to support the weight of the machine.

1. Start the engine.
2. After the engine has warmed up, adjust the throttle to approximately half speed.
3. Adjust the blades to the desired position.
 - For floating, set the blades flat, but with some tension on the cable.
 - For finishing, set the pitch of the blades to approximately 6 to 9 mm (1/4 to 3/8 inches), or approximately 5 to 10 degrees. Start with
4. Hold the handle firmly with 1 hand, and move the Dyna-Clutch lever to the On position to start the movement of the blades.
5. Guide the trowel over the concrete in a circular back-and-forth motion.

Note: If the blades start to dig into the concrete decrease the amount of the pitch.

6. Set the Dyna-Clutch lever to the Off position, wait for any moving parts to stop moving, and stop the engine; refer to Stopping the Engine (page 12).

Maintenance

Recommended Maintenance Schedule(s)

Maintenance Service Interval	Maintenance Procedure
After the first 25 hours	<ul style="list-style-type: none">• Change the engine oil.
Before each use or daily	<ul style="list-style-type: none">• Check the engine oil level.• Check the gearcase oil level.• Clean debris from the air cleaner and engine.• Lubricate the blade arms.• Inspect the air cleaner elements.• Check for loose fasteners.
Every 40 hours	<ul style="list-style-type: none">• Check the belt, pulley alignment, belt tension, and belt-guide gap.
Every 50 hours	<ul style="list-style-type: none">• Clean the air filter elements. Clean them more frequently in dusty operating conditions.
Every 100 hours	<ul style="list-style-type: none">• Change the engine oil.• Inspect and adjust the spark plug; replace it if necessary.
Every 150 hours	<ul style="list-style-type: none">• Change the gearcase oil.
Every 200 hours	<ul style="list-style-type: none">• Replace the spark plug.
Every 300 hours	<ul style="list-style-type: none">• Replace the paper air cleaner element. Replace it more frequently in dusty operating conditions.
Yearly or before storage	<ul style="list-style-type: none">• Touch up chipped paint

Premaintenance Procedures

Disconnecting the Spark Plug Wire

Before performing any maintenance on the engine, belts, or blades, disconnect the spark plug wire from the spark plug (Figure 13).

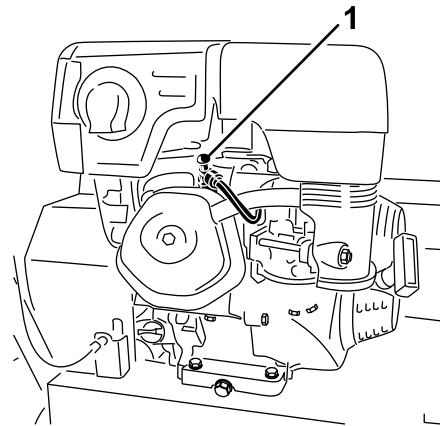

g019430

Figure 13

1. Spark-plug wire

Lubrication

Lubricating the Blade Arms

Service Interval: Before each use or daily

Grease Type: General-purpose grease.

1. Clean around each grease fitting with a rag and lift the plastic cap off each grease fitting.
2. Pump several shots of grease into each fitting until it starts to ooze out of the bearing (Figure 14 and Figure 15).

Important: Pump grease in slowly and carefully to prevent damage to the bearing seals.

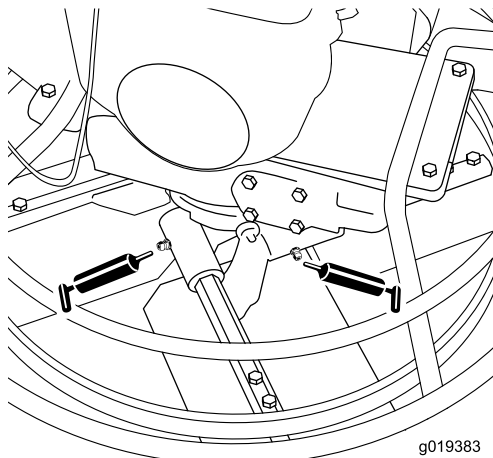

Figure 14

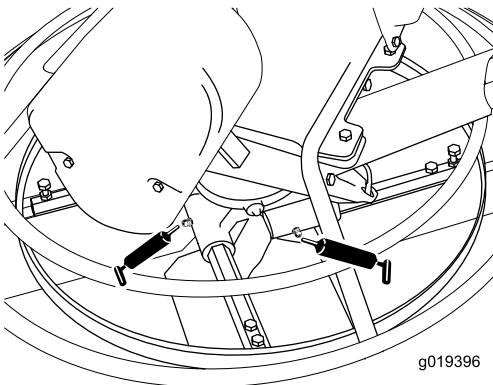

Figure 15

3. Wipe up any excess grease.

Engine Maintenance

Servicing the Air Cleaner

Service Interval: Before each use or daily—Inspect the air cleaner elements.

Every 50 hours—Clean the air filter elements. Clean them more frequently in dusty operating conditions.

Every 300 hours/Yearly (whichever comes first)—Replace the paper air cleaner element. Replace it more frequently in dusty operating conditions.

Important: Do not operate the engine without the air filter assembly; extreme engine damage will occur.

1. Set the Dyna-Clutch lever to the Stop position, stop the engine, and wait for all moving parts to stop.
2. Disconnect the wire from the spark plug.
3. Remove the nut that secures the air cleaner cover (Figure 16 Box A).

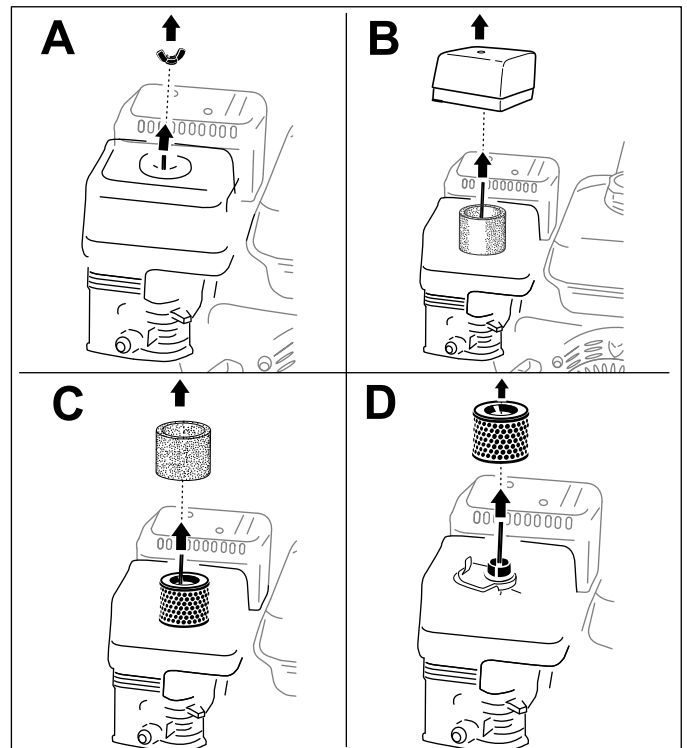
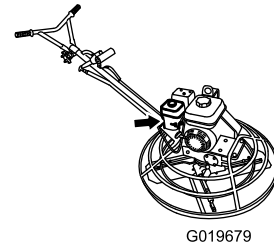

Figure 16

4. Remove the cover (Figure 16 Box B).

Note: Be careful to prevent dirt and debris from falling into the base.
5. Remove the foam and paper elements from the base (Figure 16 Box C).
6. Remove the foam element from the paper element (Figure 16 Box D).
7. Inspect the foam and paper elements, and replace them if they are damaged or excessively dirty.

Note: Never try to brush dirt off the paper element; brushing forces the dirt into the fibers.

8. Clean the foam element in warm, soapy water or in a **nonflammable** solvent.

Note: Do not use gasoline to clean the foam element because it could create a risk of fire or explosion.
9. Rinse and dry the foam element thoroughly.
10. Dip the foam element in clean engine oil, then squeeze out the excess oil.

Note: Excess oil in the foam element restricts the air flow through the element and may reach the paper filter and clog it.

11. Wipe dirt from the base and the cover with a moist rag.

Note: Be careful to prevent dirt and debris from entering the air duct leading to the carburetor.
12. Install the air cleaner elements and ensure that they are properly positioned.
13. Securely install the cover with the nut.

Servicing the Engine Oil

Oil Type: 4-cycle engine oil that meets or exceeds the requirements for API service category **SJ or higher**

Models	Crankcase Capacity
68048 and 68049	0.58 L (0.61 US qt)
68050 and 68051	1.1 L (1.2 US qt)

Important: If the oil level in the crankcase is too low or too high and you run the engine, you may damage the engine.

Viscosity: Use SAE 10W-30 for general use. You can use the other viscosities shown in the chart when the average temperature in your area is within the indicated range (Figure 8).

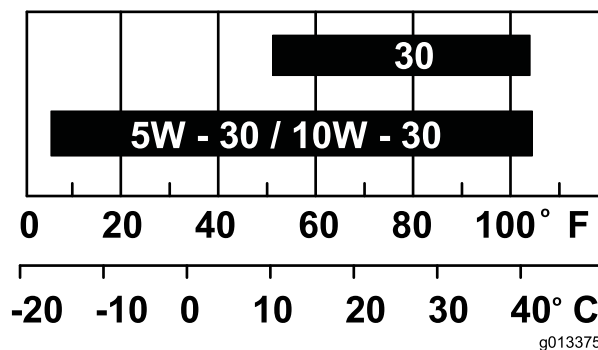

Figure 17

Changing the Engine Oil

Service Interval: After the first 25 hours
Every 100 hours

⚠ WARNING

Oil may be hot after the engine has been run, and contact with hot oil can cause severe personal injury.

Avoid contacting the hot engine oil when you drain it.

1. Move the machine to a level surface.
2. Set the Dyna-Clutch lever to the Stop position, stop the engine, and wait for all moving parts to stop.
3. Disconnect the wire from the spark plug.
4. Place a pan under the drain plug to catch the oil.
5. Remove the drain plug (Figure 18).

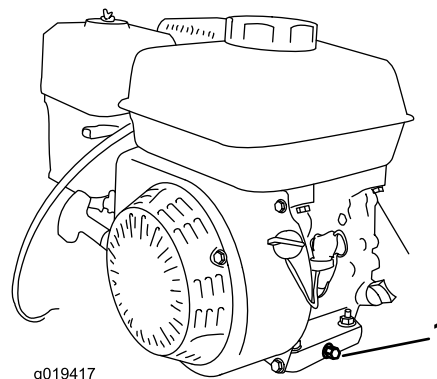

Figure 18

1. Drain plug
6. Replace the plug when the oil has drained completely.

Note: Dispose of the used oil at a certified recycling center.
7. Remove the dipstick (Figure 9) and slowly pour oil into the fill hole until the oil pours out of the fill hole.
8. Install and secure the dipstick.
9. Wipe up any spilled oil.

Servicing the Gearcase Oil

Service Interval: Every 150 hours

Oil Type: 80W-90 *gear oil* that meets or exceeds API service category *GL-5*.

Capacity: 1.18 L (1.25 US qt)

1. Set the Dyna-Clutch lever to the Stop position, stop the engine, and wait for all moving parts to stop.
2. Disconnect the wire from the spark plug.
3. Place a pan under the drain plug to catch the oil.
4. Remove the gearcase plug (Figure 18).

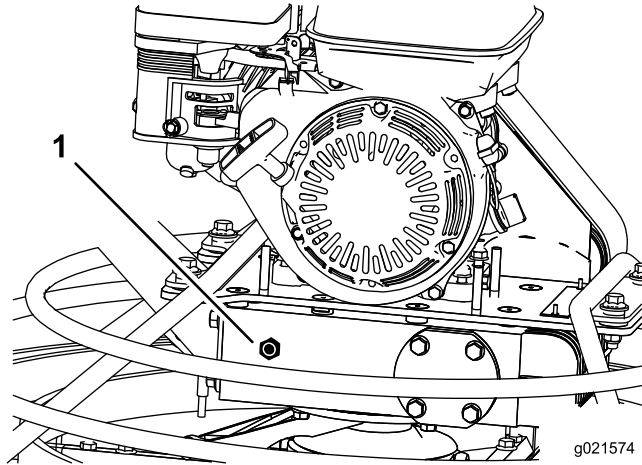
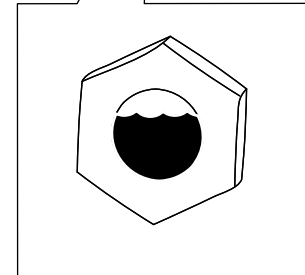
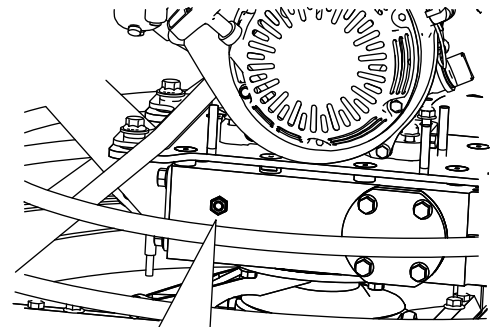

Figure 19



g021590

Figure 20

1. Gearcase plug

5. Tip the machine and drain the oil completely out of the gearcase.

Note: Dispose of the used oil at a certified recycling center.

6. Return the machine to an upright, level position.
 7. Place a 3.8 cm (1-1/2 inch) block under the stationary blade guard (outer ring) so that the side of the gearbox with the plug is approximately 6 mm (1/4 inch) higher than the other side of the gearbox.
 8. Slowly pour oil into the plug hole until the oil reaches the threads of the hole.
- Note:** If necessary, use a flexible funnel.
9. Apply thread-sealing compound to the threads of the plug.
 10. Install and tighten the plug until it is secure, and return the machine to an upright, level position.

Note: The oil level in the sight glass of the plug should be 3/4 full (Figure 20).

Servicing the Spark Plug

Service Interval: Every 100 hours—Inspect and adjust the spark plug; replace it if necessary.

Every 200 hours—Replace the spark plug.

Use an **NGK BPR6ES** spark plug or equivalent.

1. Set the Dyna-Clutch lever to the Stop position, stop the engine, and wait for all moving parts to stop.
2. Disconnect the wire from the spark plug.
3. Clean around the spark plug.
4. Remove the spark plug from the cylinder head.

Important: Replace a cracked, fouled, or dirty spark plug. Do not clean the electrodes, because grit entering the cylinder can damage the engine.

5. Set the gap on the plug to 0.76 mm (0.030 inch); refer to Figure 21.

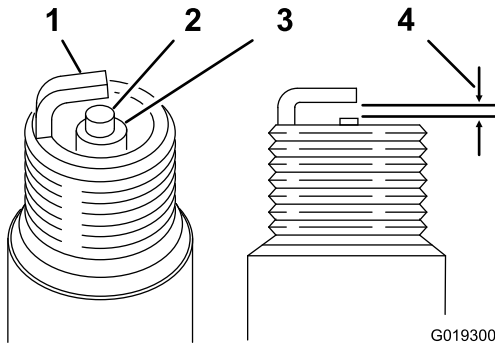

Figure 21

- | | |
|---------------------|-----------------------------|
| 1. Side electrode | 3. Insulator |
| 2. Center electrode | 4. 0.76 mm (0.030 inch) gap |

6. Carefully install the spark plug by hand (to avoid cross threading) until it is hand tight.
7. Tighten the spark plug an additional 1/2 turn if it is new; otherwise, tighten it an additional 1/8 to 1/4 turn.

Important: A loose spark plug can become very hot and can damage the engine; overtightening a spark plug may damage the threads in the cylinder head.

8. Connect the wire to the spark plug.

Belt Maintenance

Checking the Belt, Pulley Alignment, Belt Tension, and Belt-guide Gap

Service Interval: Every 40 hours

1. Remove the belt guard; refer to Removing and Installing the Belt Guard (page 18).
2. Move the Dyna-Clutch lever to the Stop position.
3. Check the condition of the belt for wear or damage.

Note: If the belt is worn or damaged, replace the belt; refer to Replacing the Belt (page 18).

4. Move the Dyna-Clutch lever to the Run position.
5. Check that the belt is aligned straight between pulleys.

Note: If the belt does not run straight between pulleys, align the pulleys; refer to Aligning the Pulleys (page 19).

6. Check that the belt has enough tension to flatten it between the engine pulley and the belt tension pulley.

Note: If belt tension is too low, adjust the tension of the belt-tension pulley; refer to Adjusting the Dyna-Clutch (page 19).

7. Measure the gap between the belt and the belt guide. The air gap should be approximately 6 mm (1/4 inch).

Note: If the air gap is larger or smaller than 6 mm (1/4 inch), adjust the belt guide (Figure 26); refer to Adjusting the Belt Guide (page 20).

8. Install the belt guard; refer to Removing and Installing the Belt Guard (page 18).

Removing and Installing the Belt Guard

Remove the belt cover as follows:

1. Remove the 2 hex-washer head bolts (5/16 x 1 inch) that secure the belt guard to the belt-guard bracket (Figure 22).

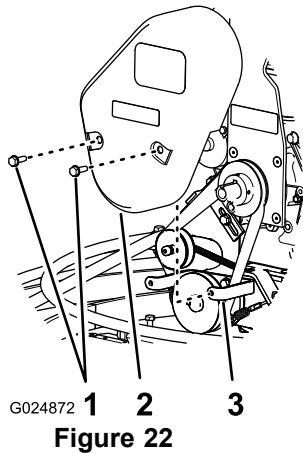

- | | |
|-------------------------|-----------------------|
| 1. Hex-washer head bolt | 3. Belt-cover bracket |
| 2. Belt cover | |

2. Pull the belt guard away from the engine and then up (Figure 22).

Install the belt cover as follows:

1. Align the holes in the belt guard with the holes in the belt-cover bracket (Figure 22).
2. Secure the belt guard to the bracket with the 2 hex-washer head bolts (5/16 x 1 inch).

Replacing the Belt

Remove the belt as follows:

1. Stop the machine on a level surface, place the Dyna-Clutch lever in the Stop position, stop the engine, and disconnect the spark plug wire.
2. Remove the belt guard; refer to Removing and Installing the Belt Guard (page 18).
3. Slip the belt off the belt-tension pulley (Figure 23).

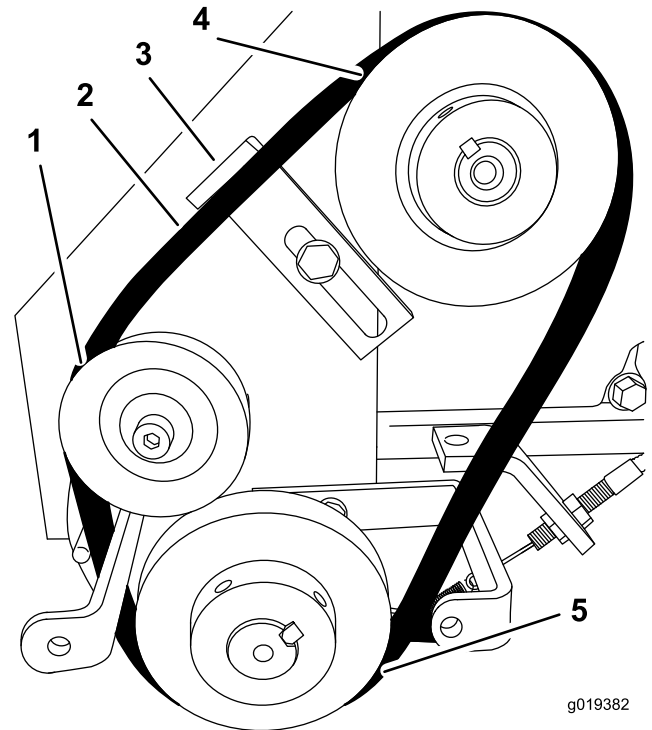

- | | |
|------------------------|-------------------|
| 1. Belt-tension pulley | 3. Gearbox pulley |
| 2. Belt | 4. Engine pulley |

4. Slip the belt off the gearbox pulley (Figure 23).
5. Slip the belt off the engine pulley and remove the belt (Figure 23).

Install the belt as follows:

1. Ensure the Dyna-Clutch lever in the Stop position.
2. Align the belt over the engine pulley (Figure 23).
3. Align the belt over the gearbox pulley (Figure 23).
4. Slip the belt over the belt-tension pulley (Figure 23).
5. Install the belt guard; refer to Removing and Installing the Belt Guard (page 18).

Aligning the Pulleys

1. Place a straightedge ruler across the engine pulley and the gearbox pulley (Figure 24).

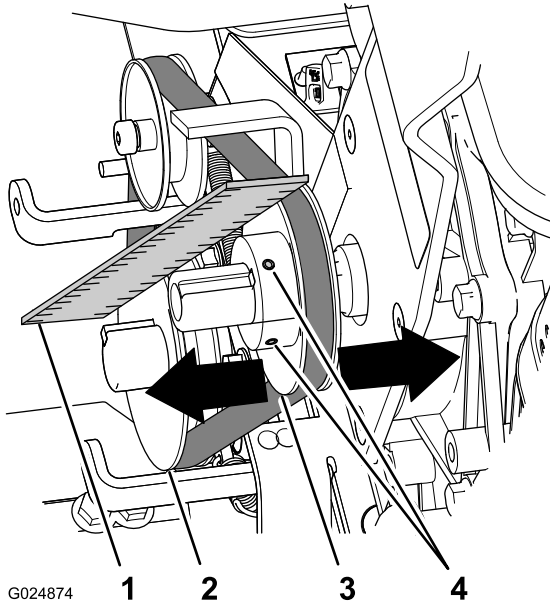

Figure 24

- | | |
|-------------------|------------------|
| 1. Straight edge | 3. Engine pulley |
| 2. Gearbox pulley | 4. Setscrew |

2. If the pulleys are out of alignment perform the following:
 - A. Loosen the 2 setscrews that secure the engine pulley to the engine shaft (Figure 24).
 - B. Gently tap the engine pulley toward or away from the engine until the gearbox and engine pulleys align to the straightedge ruler (Figure 24).
 - C. Tighten the 2 setscrews that secure the engine pulley to the engine shaft (Figure 24).

Adjusting the Dyna-Clutch

Important: This adjustment procedure affects the operation of the Dyna-Clutch and is critical to the safe operation of the machine.

Adjust the tension-pulley spring as needed to tighten the belt.

1. Move the Dyna-Clutch lever to the Stop position; refer to Dyna-Clutch Lever (page 7).
2. Loosen the 2 jam nuts that secure the barrel of the clutch cable to the clutch bracket, and rotate the nuts to either end of threads on the barrel (Figure 25).

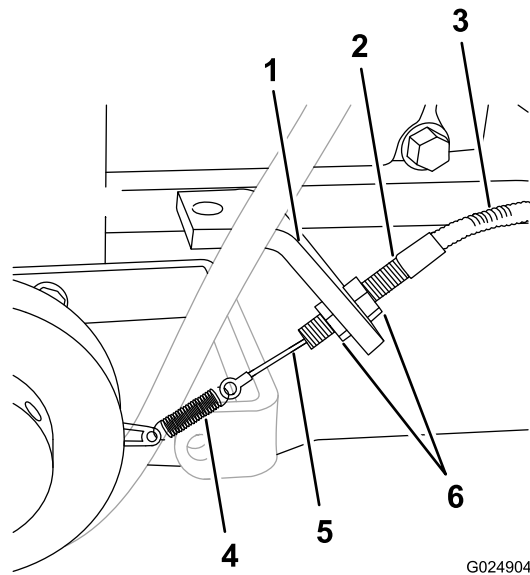

Figure 25

- | | |
|-------------------|-------------|
| 1. Clutch bracket | 4. Spring |
| 2. Barrel | 5. Cable |
| 3. Cable housing | 6. Locknuts |

3. Grasp the barrel with one hand and lift the cable housing lightly (Figure 25).

Note: Lifting the cable housing at the barrel should remove the slack from the cable but apply no tension to the spring.
4. While holding tension on the cable, use your other hand, rotate the jam nuts until the nuts are flush to the clutch bracket (Figure 25).
5. Tighten the jam nuts to secure the barrel to the bracket (Figure 25).
6. Check the tension of the control cable. Repeat steps 2 through 4 until there is tension on the Dyna-Clutch cable but no tension on the spring.

Note: If there is too much tension on the cable and spring, the Dyna-Clutch will not release completely. If there is not enough tension on the cable, the cable may disconnect from the pulley bracket.

7. If finer cable adjustment is needed, perform the following:
 - A. Loosen the 2 jam nuts slightly (Figure 25).
 - B. Rotate the jam nuts to clockwise to increase cable tension or counterclockwise to decrease tension (Figure 25).
 - C. Tighten the jam nuts to secure the barrel to the clutch bracket (Figure 25).
8. Start the machine and set Dyna-Clutch to the Run position short few moments, then move the Dyna-Clutch to the Stop position.

Note: If the blades continue to rotate when the Dyna-Clutch is in the Stop position, there is too much

tension on the clutch cable. Shut off the engine and repeat step 7 until the blades do not rotate when the engine is running and the Dyna-Clutch is in the Stop position.

Adjusting the Belt Guide

1. Place the Dyna-Clutch lever in the Run position.
2. Measure the air gap between the belt and the belt guide (Figure 26).

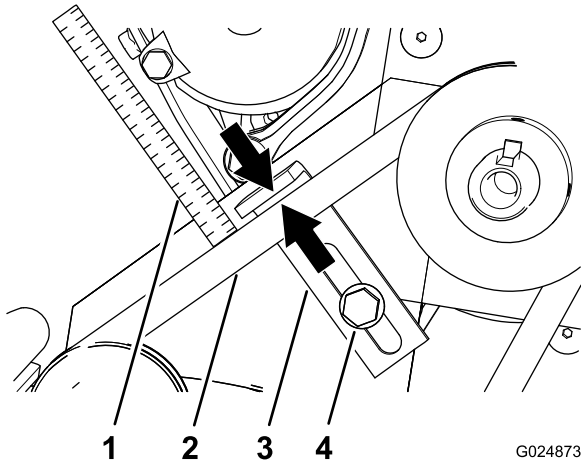

Figure 26

- | | |
|-------------------------------------|---------------|
| 1. 6 mm (1/4 inch) measures-air gap | 3. Belt guide |
| 2. Belt | 4. |

The air gap should be approximately 6 mm (1/4 inch). If an adjustment needs to be done, perform the following:

1. Loosen the hex-flange head bolt that secures the belt guide to the engine plate (Figure 26).
2. While keeping the top of the belt guide parallel to the belt, move the belt guide toward or away from the belt until the air gap is correct (Figure 26).
3. Tighten the hex-flange head bolt that secures the belt guide to the engine plate (Figure 26).

Controls System Maintenance

Adjusting the Tilt Knob

1. Set the Dyna-Clutch lever to the Stop position, stop the engine, and wait for all moving parts to stop.
2. Disconnect the wire from the spark plug.
3. Attach an overhead lift to the lifting point on the machine and lift it off of the ground.
4. Turn the tilt knob until there is enough cable slack to access the tilt locknut (Figure 27).

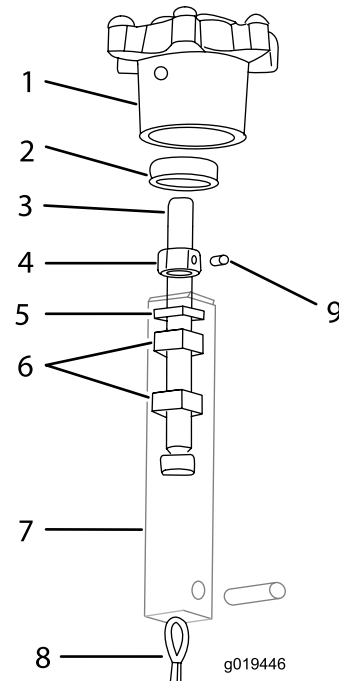

Figure 27

- | | |
|-----------------|---------------|
| 1. Tilt knob | 6. Nut |
| 2. Bearing | 7. Tilt block |
| 3. Tilt rod | 8. Tilt cable |
| 4. Tilt locknut | 9. Set screw |
| 5. Washer | |

5. Tighten the locknut against the bearing then loosen it slightly. Set it with the set screw (Figure 27).
6. Adjust the nuts inside the tilt block to take up any cable slack.

Note: Replace the cables if full tilt is no longer obtainable.

Adjusting the ProPitch Linkage Rod

1. Set the Dyna-Clutch lever to the Stop position, stop the engine, and wait for all moving parts to stop.
2. Disconnect the wire from the spark plug.
3. Attach an overhead lift to the lifting point on the machine and lift it off of the ground.
4. Loosen the nut on the upper end of the linkage rod to allow slack in the lift cable (Figure 28).

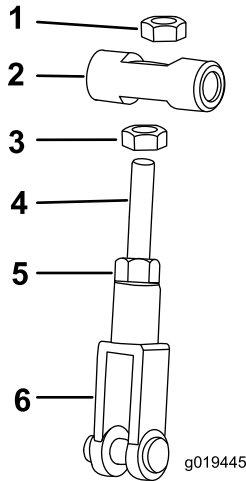

Figure 28

- | | |
|-----------|----------------|
| 1. Nut | 4. Linkage rod |
| 2. Swivel | 5. Nut |
| 3. Nut | 6. Yoke end |

5. Position the ProPitch handle in the full tilt position.
6. Adjust the nut on the backside of the swivel at the upper end of the linkage rod until you achieve the proper gap of approximately 0.4 mm (1/64 inch) between the tilt lever and the gearcase.
7. Tighten the nut on the outside of the swivel to lock the linkage rod into position.

Testing the Dyna-Clutch Lever

Testing the Dyna-Clutch Operation

Ensure that the area is clear of any debris or bystanders before beginning the testing procedures.

1. Start the trowel, engage the Dyna-Clutch lever, and run the machine for a few moments.
2. Move the Dyna-Clutch lever to the Stop position.
3. Watch the blades for any sign of continued rotation.

If the blades do not stop, there is too much tension on the cable and spring. Stop the engine and decrease the amount of tension to allow the Dyna-Clutch lever to disengage completely.

Ensure that there is still enough tension on the cable and spring to prevent parts from coming unhooked during operation. If the tendency for the blades to rotate when the Dyna-Clutch lever is disengaged cannot be adjusted out of the system without taking all tension off of the cable and spring, carefully inspect the drive belt and Dyna-Clutch lever system for wear or damage. Ensure that all parts are operating freely. If the Dyna-Clutch lever does not stop the blades, see an Authorized Service Dealer.

Testing the Dyna-Clutch Lever Adjustment

Important: Ensure that the testing of the Dyna-Clutch lever is done in a clear and open area.

Important: Clear the test area of bystanders.

1. Move the Dyna-Clutch lever to the Stop position; refer to Dyna-Clutch Lever (page 7).
2. Start the trowel.
3. Move the fuel valve to the Off position (Figure 29).

Important: You must move the fuel valve to the Off position before continuing this procedure.

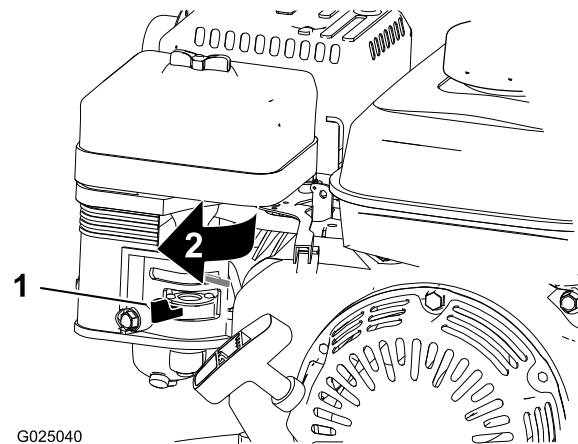

Figure 29

1. Fuel valve
2. Off position

4. Hold onto the handle and engage the Dyna-Clutch lever; refer to Dyna-Clutch Lever (page 7).
5. Let go of the handle.

The Dyna-Clutch lever should switch to the Stop position within 1 rotation. If it does not, keep clear of the area and **wait for the machine to run out of fuel.**

Note: If the Dyna-Clutch does not stop the machine within 1 rotation, adjust the Dyna-Clutch or bring the machine to an authorized service location; refer to Adjusting the Dyna-Clutch (page 19).

6. Move the Dyna-Clutch lever to the Stop position.

Adjusting the Blades

Adjust the blades to remove excessive shaking of the machine.

1. Disconnect the spark plug wire and move the Dyna-Clutch lever to the Stop position.
2. Place 3 or 4 blocks of equal height under the stationary blade guard (outer ring) to raise the blades off of the floor.

Note: Ensure that the blocks are clear of the blades so that the blades can be rotated without touching the blocks.

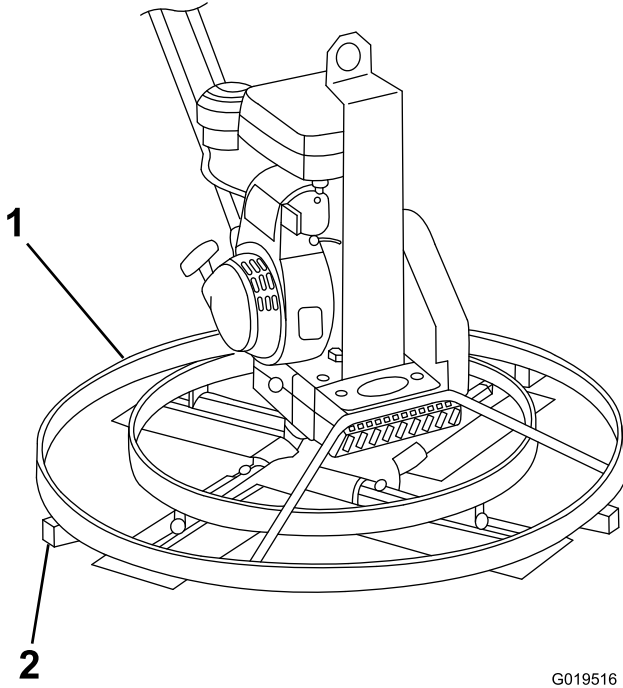

Figure 30

G019516

1. Stationary blade guard
2. Block

3. Measure from the floor to the leading edge of the blade. Note the measurement.
4. Place a mark on the blade and on the spot on the floor from where the measurement was taken (Figure 31).

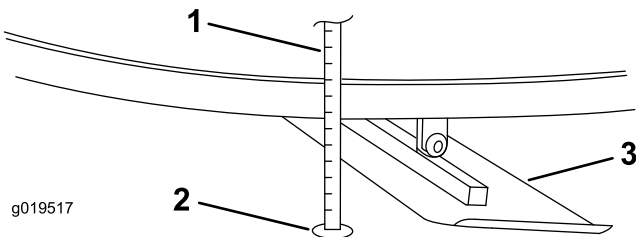

Figure 31

g019517

1. Spot on the floor where the measurement was taken
2. Ruler
3. Blade

5. Rotate the blades until the next blade is in the same position as the previously measured blade.

6. Measure the second blade from the spot previously marked on the floor to the second blades leading edge (Figure 32).

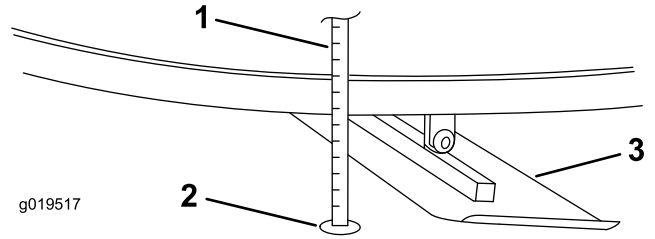

Figure 32

1. Ruler
2. Spot on floor from first measurement
3. Second blade

7. Compare the 2 measurements.

If the height of the second blade is not within 1/32 of an inch of the height of the first blade, adjust the second blade.

8. Loosen the locknuts on the blade (Figure 33).

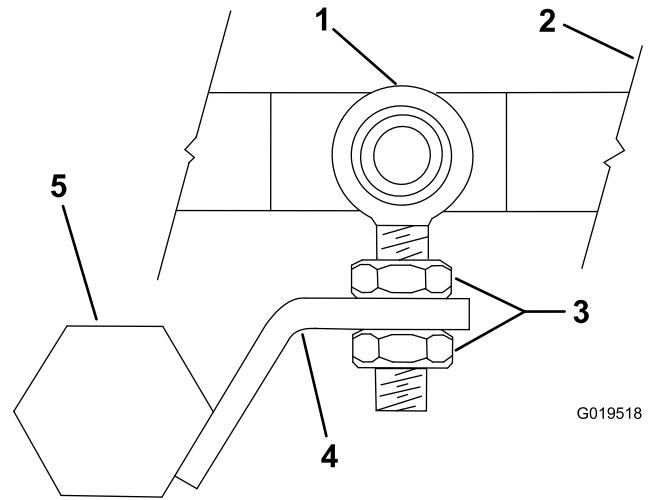

Figure 33

G019518

1. Rod end bearing
2. Thrust plate
3. Locknuts
4. Blade arm lever
5. Blade arm

9. Adjust the blade arm lever up or down as necessary to make the second blade height the same height of the first blade that was measured.
10. Tighten the locknuts.
11. Repeat as necessary for the remaining blades.

Troubleshooting

Problem	Possible Cause	Corrective Action
The trowel blade turns when the recoil is pulled.	<ol style="list-style-type: none"> 1. The clutch is engaged. 2. The clutch is not properly adjusted. 3. The belt guide bracket is bent. 	<ol style="list-style-type: none"> 1. Disengage the Clutch. 2. See Adjusting the Dyna-Clutch Lever. 3. See an Authorized Service Dealer.
The trowel blades are wearing unevenly.	<ol style="list-style-type: none"> 1. The blade arm is bent. 2. The blade arm need to be adjusted. 3. The tilt mechanism needs to be adjusted. 4. The rod end bearings are worn or needs to be adjusted. 	<ol style="list-style-type: none"> 1. See Adjusting the Blade Arms. 2. See Adjusting the Blade Arms. 3. See Adjusting the Blade Arms. 4. See Adjusting the Blade Arms.
The trowel bounces, rocks, or digs into the concrete.	<ol style="list-style-type: none"> 1. The blade arm is bent. 2. The blade arm needs to be adjusted. 3. The arm bearings are worn. 4. The output shaft is bent. 	<ol style="list-style-type: none"> 1. See Adjusting the Blade Arms. 2. See Adjusting the Blade Arms. 3. See an Authorized Service Dealer. 4. See an Authorized Service Dealer.
The tilt knob is difficult to turn.	<ol style="list-style-type: none"> 1. The tilt rod and nut are seized. 2. The tilt pivot is not seated properly. 3. The tilt locknut needs to be adjusted. 4. The thrust plate is worn or has seized. 5. The tilt lever is worn or bent. 6. The ProPitch cam is bent or worn. 	<ol style="list-style-type: none"> 1. Lubricate the tilt rod threads. 2. See Adjusting the Tilt Knob. 3. See Adjusting the Tilt Knob. 4. Lubricate the thrust plate. See an Authorized Service Dealer. 5. See an Authorized Service Dealer. 6. See Adjusting the Pro-Pitch Linkage Rod. See an Authorized Service Dealer.
The Dyna-Clutch lever is difficult to engage.	<ol style="list-style-type: none"> 1. The tension needs to be adjusted. 2. The Dyna-Clutch lever is worn. 3. The cable has seized. 	<ol style="list-style-type: none"> 1. See Adjusting the Dyna-Clutch Lever. 2. See an Authorized Service Dealer. 3. See an Authorized Service Dealer.
The belt slips.	<ol style="list-style-type: none"> 1. The tension on the clutch spring needs to be adjusted. 2. The belt is worn. 	<ol style="list-style-type: none"> 1. See Adjusting the Dyna-Clutch Lever. 2. See Adjusting the Transmission Drive Belt Tension.
The gearcase is emitting a grinding noise.	<ol style="list-style-type: none"> 1. The bearings are worn. 	<ol style="list-style-type: none"> 1. See an Authorized Service Dealer.
The engine will not start.	<ol style="list-style-type: none"> 1. The choke is open. 2. The fuel tank is empty. 3. The spark plug wire is loose or disconnected. 	<ol style="list-style-type: none"> 1. Close the choke when starting a cold engine. 2. Fill the tank with fresh fuel. 3. Check the electrode gap and clean or replace the spark plug.
The engine runs rough.	<ol style="list-style-type: none"> 1. The choke is left on. 2. The air filter is clogged. 3. The fuel line is clogged. 4. There is water or contaminants in the fuel. 5. The spark plugs are worn or have buildup on the electrodes. 	<ol style="list-style-type: none"> 1. Open the choke. 2. Clean or replace the air filter. See Servicing the Air Cleaner. 3. Clean the sediment cup. 4. Drain and fill the tank with fresh fuel. 5. Check the electrode gap and clean or replace the spark plug.

Notes:

Notes:

Notes:



The Toro Warranty

A limited warranty (see warranty periods below)

Conditions and Products Covered

The Toro Company and its affiliate, Toro Warranty Company, pursuant to an agreement between them, jointly warrant your Toro Concrete, Masonry, and Compaction Equipment Products listed below to be free from defects in materials or workmanship.

This warranty covers the cost of parts and labor, but you must pay transportation costs.

The following time periods apply from the date of purchase:

Products	Warranty Period
Concrete Mixers	1 year
• Spindle Bearings	Lifetime* (original owner only)
Mortar Mixers	1 year
• Drum Bearings and Seals	Lifetime* (original owner only)
Forward Plate Compactors	2 years
Reversible Plates	1 year
Rammer Compactors	2 years
Mud Buggy	1 year
Vibrating Trench Roller	2 years
Concrete Saws	1 year
Masonry Saws	1 year
Power Trowels	1 year
Screeds	1 year
Concrete Vibrators	1 year

Where a warrantable condition exists, we will repair the Product at no cost to you including diagnosis, labor, and parts.

*Lifetime Warranty - If the bearing(s) or seal(s) on your mixer fail, it will be replaced under warranty, at no cost for parts or labor.

Instructions for Obtaining Warranty Service

If you think that your Toro Product contains a defect in materials or workmanship, follow this procedure**:

1. Contact any Authorized Servicing Outlet to arrange service at their dealership. To locate one convenient to you, access our website at www.Toro.com. Select "Where to Buy" and select "Contractor" under product type. You may also call our toll free number below.
2. Bring the product and your proof of purchase (sales receipt) to them.
3. If for any reason you are dissatisfied with the Service Outlet's analysis or with the assistance provided, contact us at:

SWS Customer Care Department
Toro Warranty Company
8111 Lyndale Avenue South
Bloomington, MN 55420-1196
Toll Free: 800-888-9926

**Toro Authorized Rental Customers who have purchased products directly from Toro and have signed the Toro Rental Customer Agreement have the ability to perform their own warranty work. Please visit Toro's Rental Portal for electronic warranty claim filing procedures or call the toll free number above.

Owner Responsibilities

You must maintain your Toro Product by following the maintenance procedures described in the *Operator's Manual*. Such routine maintenance, whether performed by a dealer or by you, is at your expense. Parts scheduled for replacement as required maintenance ("Maintenance Parts"), are warranted for the period of time up to the scheduled replacement time for that part. Failure to perform required maintenance and adjustments can be grounds for disallowing a warranty claim.

Items and Conditions Not Covered

Not all product failures or malfunctions that occur during the warranty period are defects in materials or workmanship. This express warranty does not cover the following:

- Product failures which result from the use of non-Toro replacement parts, or from installation and use of add-on, modified, or unapproved accessories
- Product failures which result from failure to perform required maintenance and/or adjustments
- Product failures which result from operating the Product in an abusive, negligent or reckless manner
- Parts subject to consumption through use unless found to be defective. Examples of parts which are consumed, or used up, during normal product operation include, but are not limited to, belts, wipers, spark plugs, tires, filters, gaskets, wear plates, seals, O-rings, drive chains, clutches.
- Failures caused by outside influence. Items considered to be outside influence include, but are not limited to, weather, storage practices, contamination, use of unapproved coolants, lubricants, additives, or chemicals, etc.
- Normal "wear and tear" items. Normal "wear and tear" includes, but is not limited to, worn painted surfaces, scratched decals, etc.
- Repairs necessary due to failure to follow recommended fuel procedure (consult *Operator's Manual* for more details)
 - Removing contaminants from the fuel system is not covered
 - Use of old fuel (more than one month old) or fuel which contains more than 10% ethanol or more than 15% MTBE
 - Failure to drain the fuel system prior to any period of non-use over one month
- Any component covered by a separate manufacturer's warranty
- Pickup and delivery charges

General Conditions

Repair by an Authorized Servicing Outlet or Self-Service as an Authorized Rental Customer is your sole remedy under the warranty.

Neither The Toro Company nor Toro Warranty Company is liable for indirect, incidental or consequential damages in connection with the use of the Toro Products covered by this warranty, including any cost or expense of providing substitute equipment or service during reasonable periods of malfunction or non-use pending completion of repairs under this warranty. All implied warranties of merchantability and fitness for use are limited to the duration of this express warranty. Some states do not allow exclusions of incidental or consequential damages, or limitations on how long an implied warranty lasts, so the above exclusions and limitations may not apply to you.

This warranty gives you specific legal rights, and you may also have other rights which vary from state to state.

Except for the engine warranty coverage and the Emissions warranty referenced below, if applicable, there is no other express warranty. The Emissions Control System on your Product may be covered by a separate warranty meeting requirements established by the U.S. Environmental Protection Agency (EPA) or the California Air Resources Board (CARB). Refer to the California Emission Control Warranty Statement supplied with your Product or contained in the engine manufacturer's documentation for details.

Countries Other than the United States or Canada

Customers who have purchased Toro products outside the United States or Canada should contact their Toro Distributor (Dealer) to obtain guarantee policies for your country, province, or state. If for any reason you are dissatisfied with your Distributor's service or have difficulty obtaining guarantee information, contact the Toro importer. If all other remedies fail, you may contact us at Toro Warranty Company.

Australian Consumer Law: Australian customers will find details relating to the Australian Consumer Law either inside the box or at your local Toro Dealer.