



**Count on it.**

**Operator's Manual**

**72in Guardian® Recycler® Mower  
72in Side-Discharge Mower  
Groundsmaster® 3280-D Traction Unit**

Model No. 31335—Serial No. 314000001 and Up

Model No. 31336—Serial No. 314000001 and Up



This product complies with all relevant European directives, for details please see the separate product specific Declaration of Conformity (DOC) sheet.

# Introduction

This rotary-blade lawn cutting deck is mounted to a ride-on machine and is intended to be used by professional, hired operators in commercial applications. It is primarily designed for cutting grass on well-maintained lawns in parks, sports fields, and on commercial grounds. It is not designed for cutting brush, mowing grass and other growth alongside highways, or for agricultural uses.

Read this information carefully to learn how to operate and maintain your product properly and to avoid injury and product damage. You are responsible for operating the product properly and safely.

You may contact Toro directly at [www.Toro.com](http://www.Toro.com) for product and accessory information, help finding a dealer, or to register your product.

Whenever you need service, genuine Toro parts, or additional information, contact an Authorized Service Dealer or Toro Customer Service and have the model and serial numbers of your product ready. The model and serial numbers are stamped into a plate that is mounted on the mower housing. Write the numbers in the space provided.

<b>Model No.</b> _____
<b>Serial No.</b> _____

This manual identifies potential hazards and has safety messages identified by the safety alert symbol (Figure 1), which signals a hazard that may cause serious injury or death if you do not follow the recommended precautions.



**Figure 1**

1. Safety alert symbol

---

This manual uses 2 other words to highlight information.

**Important** calls attention to special mechanical information and **Note** emphasizes general information worthy of special attention.

# Contents

Introduction .....	2
Safety .....	4
Safe Operating Practices.....	4
Toro Mower Safety .....	5
Safety and Instructional Decals .....	7
Setup .....	9
1 Securing the Grass Deflector(Model 31336 only) .....	10
2 Installing the Lift Arms to the Traction Unit .....	10
3 Connecting the Lift Arms to the Cutting Unit .....	11
4 Connecting the PTO Shaft to the Cutting Unit Gear Box .....	11
5 Greasing the Machine .....	12
Product Overview .....	12
Specifications .....	12
Attachments/Accessories.....	12
Operation .....	13
Checking the Lubricant in the Gear Box.....	13
Adjusting the Height-of-Cut .....	13
Adjusting the Rollers.....	14
Adjusting the Skids .....	15
Adjusting the Anti-Scalp Rollers .....	15
Adjusting the Flow Baffle(Model 31336 only) .....	15
Positioning the Flow Baffle(Model 31336 only) .....	16
Adjusting the Cutting Unit Pitch.....	17
Correcting Cutting Unit Mismatch .....	17
Using the Side Discharge(Model 31336 only) .....	17
Operating Tips .....	18
Maintenance .....	19
Recommended Maintenance Schedule(s) .....	19
Lubrication.....	20
Pre Maintenance .....	21
Separating the Cutting Unit from the Traction Unit .....	21
Mounting the Cutting Unit to the Traction Unit .....	21
Servicing the Bushings in the Castor Arms .....	22
Servicing the Castor Wheels and Bearings .....	22
Checking for a Bent Blade.....	23
Removing and Installing the Blade(s).....	23
Inspecting and Sharpening the Blade(s).....	24
Checking and Correcting Mismatch of Blades .....	25
Replacing the Drive Belt .....	25
Replacing the Grass Deflector .....	26

# Safety

This machine meets or exceeds CEN standard EN 836:1997, ISO standard 5395:1990, and ANSI B71.4-2004 specifications in effect at the time of production.

Improper use or maintenance by the operator or owner can result in injury. To reduce the potential for injury, comply with these safety instructions and always pay attention to the safety alert symbol, which means CAUTION, WARNING, or DANGER- "personal safety instruction." Failure to comply with the instruction may result in personal injury or death.

## Safe Operating Practices

The following instructions are adapted from the CEN standard EN 836:1997, ISO standard 5395:1990, and ANSI B71.4-2004.

### Training

- Read the operator's manual and other training material carefully. Be familiar with the controls, safety signs, and the proper use of the equipment. If the operator or mechanic can not read the language of this manual, it is the owner's responsibility to explain this material to them.
- Become familiar with the safe operation of the equipment, operator controls, and safety signs.
- All operators and mechanics should be trained. The owner is responsible for training the users
- Never let children or untrained people operate or service the equipment. Local regulations may restrict the age of the operator.
- The owner/user can prevent and is responsible for accidents or injuries occurring to himself or herself, other people, or property.

### Preparation

- Evaluate the terrain to determine what accessories and attachments are needed to properly and safely perform the job. Only use accessories and attachments approved by the manufacturer.
- Wear appropriate clothing including hard hat, safety glasses and ear protection. Long hair, loose clothing or jewelry may get tangled in moving parts.
- Inspect the area where the equipment is to be used and remove all objects such as rocks, toys and wire which can be thrown by the machine.
- Check that operator's presence controls, safety switches and shields are attached and functioning properly. Do not operate unless they are functioning properly.

### Safe Handling of Fuels

- To avoid personal injury or property damage, use extreme care in handling gasoline. Gasoline is extremely flammable and the vapors are explosive.

- Extinguish all cigarettes, cigars, pipes, and other sources of ignition.
- Use only an approved fuel container.
- Never remove fuel cap or add fuel with the engine running.
- Allow engine to cool before refueling.
- Never refuel the machine indoors.
- Never store the machine or fuel container where there is an open flame, spark, or pilot light such as on a water heater or on other appliances.
- Never fill containers inside a vehicle or on a truck or trailer bed with a plastic liner. Always place containers on the ground away from your vehicle before filling.
- Remove equipment from the truck or trailer and refuel it on the ground. If this is not possible, then refuel such equipment with a portable container, rather than from a fuel dispenser nozzle.
- Keep the nozzle in contact with the rim of the fuel tank or container opening at all times until fueling is complete. Do not use a nozzle lock open device.
- If fuel is spilled on clothing, change clothing immediately.
- Never overfill fuel tank. Replace fuel cap and tighten securely.

### Operation

- Never run an engine in an enclosed area.
- Only operate in good light, keeping away from holes and hidden hazards.
- Be sure all drives are in neutral and parking brake is engaged before starting engine. Only start engine from the operator's position. Always use the seat belts when the ROPS is in the raised position. Do not use the seat belts when the ROPS is in the lowered position.
- Slow down and use extra care on hillsides. Be sure to travel in the recommended direction on hillsides. Turf conditions can affect the machine's stability. Use caution while operating near drop-offs.
- Slow down and use caution when making turns and when changing directions on slopes.
- Never raise deck with the blades running.
- Never operate with guards not securely in place. Be sure all interlocks are attached, adjusted properly, and functioning properly.
- Do not change the engine governor setting or overspeed the engine.
- Stop on level ground, lower the cutting units, disengage drives, engage parking brake (if provided), shut off engine before leaving the operator's position for any reason.
- Stop equipment and inspect the blades after striking objects or if an abnormal vibration occurs. Make necessary repairs before resuming operations.

- Keep hands and feet away from the cutting units.
- Look behind and down before backing up to be sure of a clear path.
- Never carry passengers and keep pets and bystanders away.
- Slow down and use caution when making turns and crossing roads and sidewalks. Stop blades if not mowing.
- Do not operate the mower under the influence of alcohol or drugs.
- Lightning can cause severe injury or death. If lightning is seen or thunder is heard in the area, do not operate the machine; seek shelter.
- Use care when loading or unloading the machine into a trailer or truck.
- Use care when approaching blind corners, shrubs, trees, or other objects that may obscure vision.
- The operator shall turn on flashing warning lights, if provided, whenever traveling on a public road, except where such use is prohibited by law.

## Maintenance and Storage

- Disengage drives, lower the cutting units, move traction pedal to Neutral, set parking brake, stop engine and remove key. Wait for all movement to stop before adjusting, cleaning or repairing.
- Clean grass and debris from cutting units, drives, muffler. Let engine cool before storing and do not store near flames, and engine to help prevent fires. Clean up oil or fuel spillage.
- Let engine cool before storing and do not store near flame.
- Shut off fuel while storing or transporting. Do not store fuel near flames or drain indoors.
- Park machine on level ground. Never allow untrained personnel to service machine.
- Use jack stands to support components when required.
- Carefully release pressure from components with stored energy.
- Disconnect battery before making any repairs. Disconnect the negative terminal first and the positive last. Reconnect positive first and negative last.
- Use care when checking blades. Wrap the blades or wear gloves, and use caution when servicing them. Only replace blades. Never straighten or weld them.
- Keep hands and feet away from moving parts. If possible, do not make adjustments with the engine running.
- Charge batteries in an open well ventilated area, away from spark and flames. Unplug charger before connecting or disconnecting from battery. Wear protective clothing and use insulated tools.
- Keep all parts in good working condition and all hardware tightened. Replace all worn or damaged decals.

## Hauling

- Use care when loading or unloading the machine into a trailer or truck.
- Use full width ramps for loading machine into trailer or truck.
- Tie the machine down securely using straps, chains, cable, or ropes. Both front and rear straps should be directed down and outward from the machine. Make sure the engine hood is securely strapped down.

## Toro Mower Safety

The following list contains safety information specific to Toro products or other safety information that you must know that is not included in the CEN, ISO, or ANSI standard.

This product is capable of amputating hands and feet and throwing objects. Always follow all safety instructions to avoid serious injury or death.

Use of this product for purposes other than its intended use could prove dangerous to user and bystanders.

- Know how to stop the engine quickly.
- Do not operate the machine while wearing tennis shoes or sneakers.
- Wearing safety shoes and long pants is advisable and required by some local ordinances and insurance regulations.
- Handle fuel carefully. Wipe up any spills.
- Check the safety interlock switches daily for proper operation. If a switch should fail, replace the switch before operating the machine.
- Using the machine demands attention. To prevent loss of control:
  - Do not drive close to sand traps, ditches, creeks, embankments, or other hazards.
  - Avoid sudden stops and starts.
  - When near or crossing roads, always yield the right-of-way.
  - Lower the cutting unit when going down slopes.
- The grass deflector must always be installed and in the lowest position on the side discharge cutting unit. Never operate the mower without the deflector or entire grass collector.
- If the cutting unit discharge area ever plugs, shut the engine off before removing the obstruction.
- Cut grass slopes carefully. Do not start, stop, or turn suddenly.
- Do not touch the engine or muffler while the engine is running or soon after it has stopped because these areas could be hot enough to cause burns.

## Maintenance and Storage

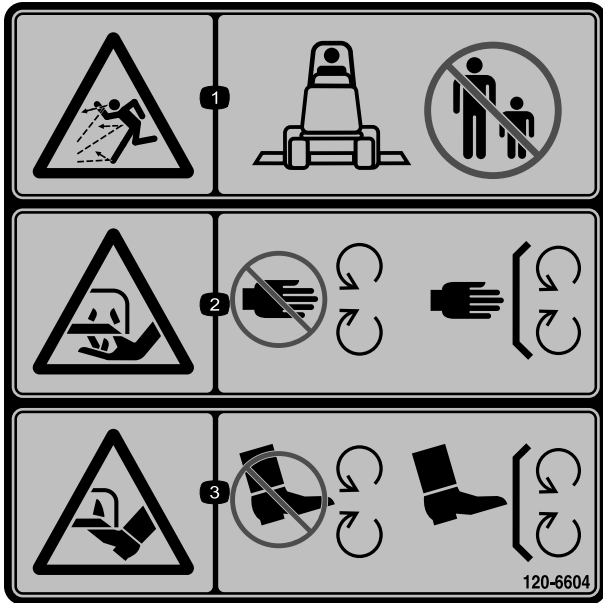
- Check the blade mounting bolts frequently to be sure that they are tightened to specification.

- Make sure that all hydraulic line connectors are tight and all hydraulic hoses and lines are in good condition before applying pressure to the system.
- Keep your body and hands away from pin hole leaks or nozzles that eject hydraulic fluid under high pressure. Use paper or cardboard, not your hands, to search for leaks. Hydraulic fluid escaping under pressure can have sufficient force to penetrate the skin and cause serious injury.
- Before disconnecting or performing any work on the hydraulic system, all pressure in the system must be relieved by stopping the engine and lowering the cutting units to the ground.
- If the engine must be running to perform a maintenance adjustment, keep hands, feet, clothing, and any parts of the body away from the cutting units, attachments, and any moving parts. Keep everyone away.
- Do not overspeed the engine by changing governor settings. To ensure safety and accuracy, have an Authorized Toro Distributor check the maximum engine speed with a tachometer.
- The engine must be shut off before checking the oil or adding oil to the crankcase.
- Make sure that the mower fuel tank is empty if the machine is to be stored in excess of 30 days. Do not store the mower near any open flame or where gasoline fumes may be ignited by a spark.
- Perform only those maintenance instructions described in this manual. If major repairs are ever needed or if assistance is desired, contact an Authorized Toro Distributor.
- To make sure of optimum performance and continued safety certification of the machine, use only genuine Toro replacement parts and accessories. Replacement parts and accessories made by other manufacturers could be dangerous, and such use could void the product warranty.

# Safety and Instructional Decals

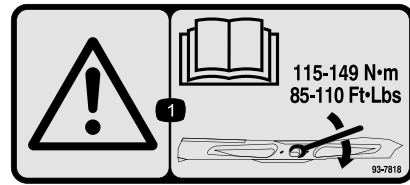


Safety decals and instructions are easily visible to the operator and are located near any area of potential danger. Replace any decal that is damaged or lost.



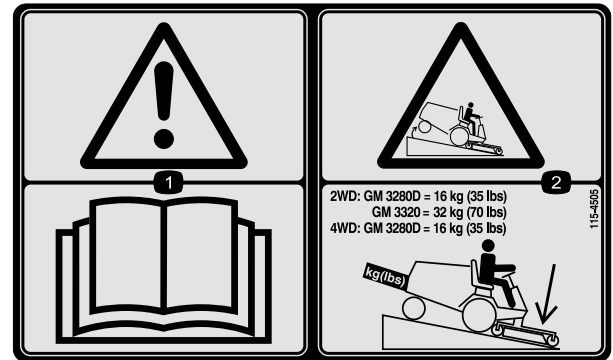
120-6604

1. Thrown object hazard—keep bystanders away from the machine.
2. Cutting/dismemberment hazard of hand, mower blade—stay away from moving parts, keep all guards and shields in place.
3. Cutting/dismemberment hazard of foot, mower blade—stay away from moving parts, keep all guards and shields in place.



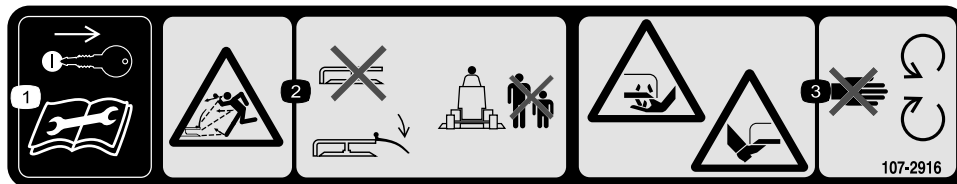
93-7818

1. Warning—read the *Operator's Manual* for instructions on torquing the blade bolt/nut to 115-149 N-m (85-110 ft-lb).



115-4505

1. Warning—read the *Operator's Manual*.
2. Tipping hazard—lower the cutting unit when driving down slopes. For 2 wheel drive units, add a 16 kg (35 lb) rear weight to GM 3280D units and a 32 kg (70 lb) rear weight to GM 3320 units. For 4 wheel drive 3280 D units, add a 16 kg (35 lb) rear weight.



107-2916

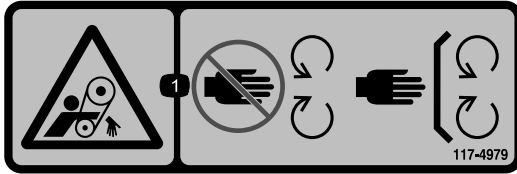
Model 31336 only

1. Remove the ignition key and read the *Operator's Manual* before servicing or performing maintenance.
2. Thrown object hazard—do not operate the mower with the deflector up or removed, keep the deflector in place; keep bystanders a safe distance from the machine.
3. Cutting/dismemberment hazard of hand or foot, mower blade—stay away from moving parts.



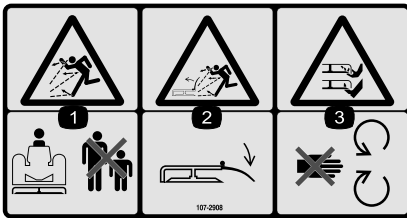
93-6697

1. Read the *Operator's Manual*.
2. Add SAE 80W-90 (API GL-5) oil every 50 hours.



117-4979

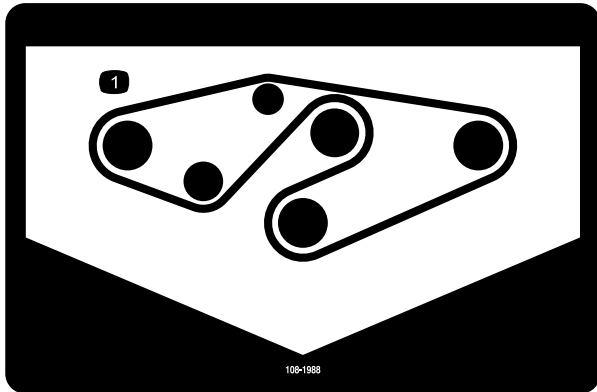
1. Entanglement hazard, belt—stay away from moving parts, keep all guards and shields in place.



107-2908

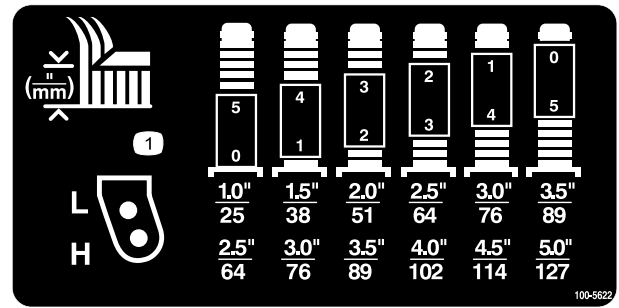
Model 31336 only

1. Thrown object hazard—keep bystanders a safe distance from the machine.
2. Thrown object hazard—do not operate the mower with the deflector up or removed, keep the deflector in place.
3. Cutting/dismemberment hazard of hand or foot, mower blade—stay away from moving parts.



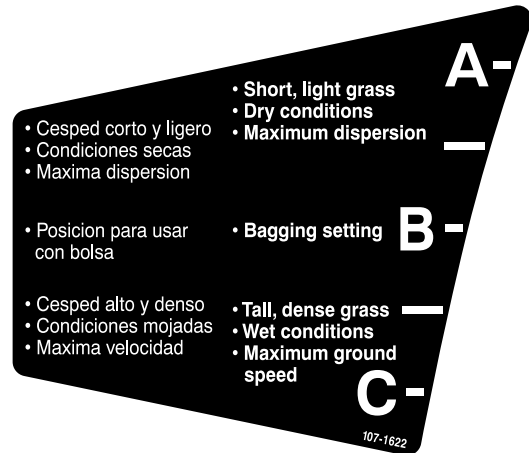
108-1988

1. Belt routing



100-5622

1. Height of cut adjustment



107-1622

Model 31336 only

# Setup

## Loose Parts

Use the chart below to verify that all parts have been shipped.

Procedure	Description	Qty.	Use
<b>1</b>	No parts required	–	Secure the grass deflector
<b>2</b>	Lift arm, right Lift arm, left	1 1	Install the lift arms to the traction unit
<b>3</b>	No parts required	–	Connect the lift arms to the cutting unit
<b>4</b>	No parts required	–	Connect the PTO shaft to the cutting unit gear box.
<b>5</b>	No parts required	–	Grease the machine.

## Media and Additional Parts

Description	Qty.	Use
Operator's Manual	1	Review the material and save in an appropriate place
Parts Catalog	1	Use to reference part numbers
Declaration of Conformity	1	

### **⚠ WARNING**

If you leave the key in the ignition switch, someone could accidentally start the engine and seriously injure you or other bystanders.

Remove the key from the ignition switch before you do any maintenance.

### **⚠ DANGER**

If the engine is started and the PTO shaft is allowed to rotate, serious injury could result.

Do not start the engine and engage the PTO switch when the PTO shaft is not connected to the gear box on the cutting unit.

**Note:** Determine the left and right sides of the machine from the normal operating position.

**Important:** If the 72 inch Side Discharge Cutting Unit, model 31336, is being mounted to a model 30307, 30308, 30309, 30343, 30344 or 30345 traction unit with a serial number prior to 311000301, the Cutting Unit Alignment Kit, part number 120-6599 must be installed to the cutting unit prior to being mounted to traction unit.

# 1

## Securing the Grass Deflector (Model 31336 only)

### No Parts Required

### Procedure

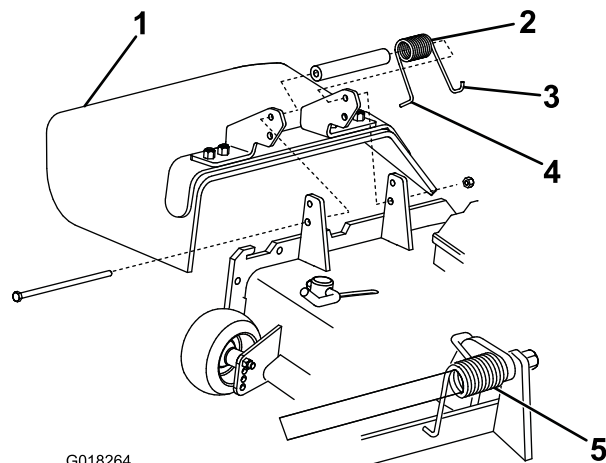
#### **⚠ WARNING**

An uncovered discharge opening could allow the lawn mower to throw objects in the operator's or bystander's direction and result in serious injury. Also, contact with the blade could occur.

- Never operate the lawn mower unless you install a cover plate, a mulch plate, or a grass chute and catcher.
- Make sure the grass deflector is in the down position.

1. Remove the cable tie securing the grass deflector to the top of the deck and lower the deflector.
2. Place the left hand **J** hook end of the spring around the deck edge
3. Place the right hand **J** hook end of the spring around the grass deflector (Figure 2).

**Important:** The grass deflector must be able to lower down into position. Lift the deflector up to test that it lowers into the full down position.



G018264

**Figure 2**

1. Grass Deflector
2. Spring
3. Right hand hook end of spring, place around deflector
4. Left hand hook end of spring, place behind deck edge
5. Spring installed

# 2

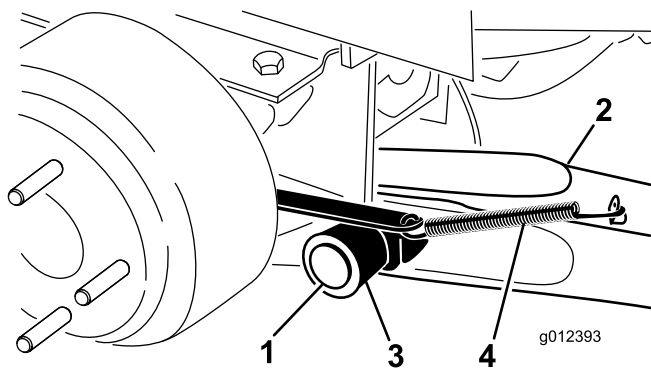
## Installing the Lift Arms to the Traction Unit

### Parts needed for this procedure:

1	Lift arm, right
1	Lift arm, left

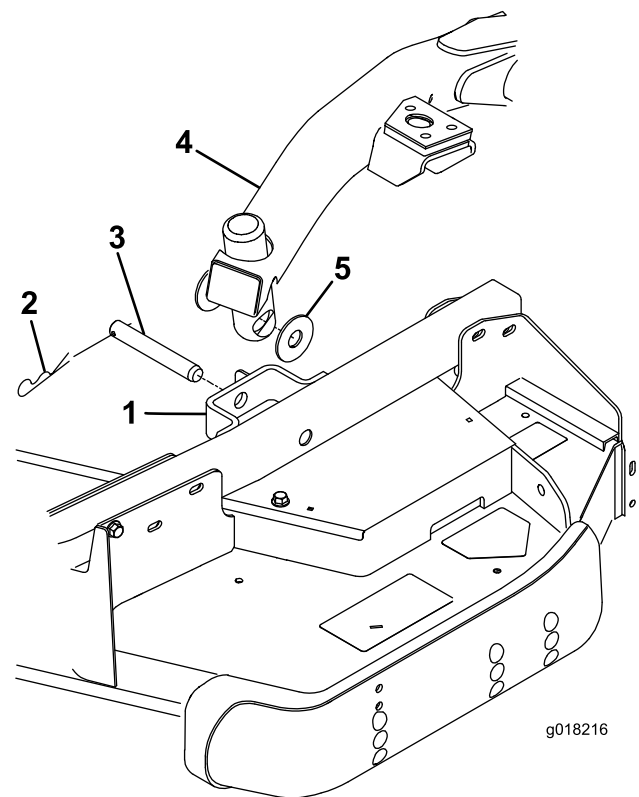
### Procedure

1. On one side of the traction unit, loosen (do not remove) the wheel nuts securing the wheel and tire assembly to the front wheel studs.
2. Jack up the machine until the front wheel is off of the floor. Use jack stands or block the machine to prevent it from accidentally falling.
3. Remove the wheel nuts and slide the wheel and tire assembly off of the studs.
4. Remove the lift arms from the pallet.
5. Remove the pivot pin and cotter pin from each lift arm.
6. Mount a lift arm to the pivot bracket with a pivot pin and a cotter pin (Figure 3). Mount the lift arm with the bend positioned outward.
7. Hook the brake return spring to the tab on the lift arm (Figure 3).



**Figure 3**

- |                  |                        |
|------------------|------------------------|
| 1. Pivot pin     | 4. Brake return spring |
| 2. Lift arm      | 5. Tab                 |
| 3. Pivot bracket |                        |



**Figure 4**

- |                       |                  |
|-----------------------|------------------|
| 1. Castor arm bracket | 4. Lift arm      |
| 2. Hairpin cotter     | 5. Thrust washer |
| 3. Clevis pin         |                  |

8. Install the wheel and tire assembly. Torque the wheel nuts to 102-108 N-m (75-80 ft-lb).
9. Repeat the procedure on the opposite side of the machine.

# 3

## Connecting the Lift Arms to the Cutting Unit

### No Parts Required

### Procedure

1. Remove the (2) thrust washers, clevis pin and hairpin cotter from each castor arm bracket on the cutting unit (Figure 4).
2. Move the cutting unit into position in front of the traction unit.
3. Press the lift switch forward to the Float position. Push a lift arm down until the holes in the lift arm line up with the holes in the castor arm bracket (Figure 4).

4. Secure the lift arm to the castor arm with the (2) thrust washers, clevis pin and hair pin cotter. Position the thrust washers between the lift arm and the castor arm bracket (Figure 4). Insert end of cotter pin into the slot in the castor arm tab to retain cotter pin.
5. Repeat the procedure on the opposite lift arm.
6. Start the traction unit and raise the cutting unit.

# 4

## Connecting the PTO Shaft to the Cutting Unit Gear Box

### No Parts Required

### Procedure

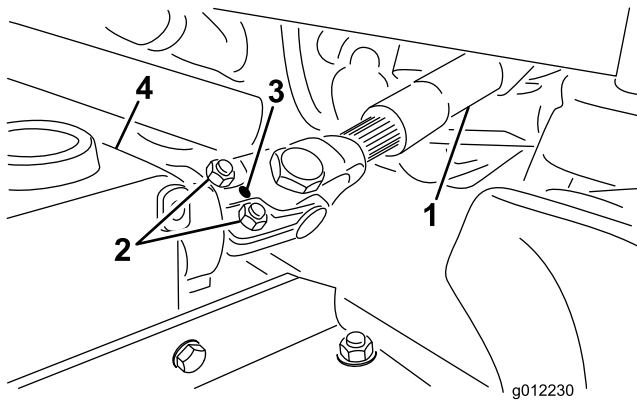
1. Slide the male PTO shaft into the female PTO shaft. Align the mounting holes in the gear case input shaft with the holes in the PTO shaft and slide them together.

# Product Overview

## Specifications

**Note:** Specifications and design are subject to change without notice.

Width of Cut	1.829 m (72 inches )
Height of Cut	Adjustable from 25 to 127 mm (1 to 5 inches ) in 13 mm (1/2 inch) increments
Net Weight	Model 31335–251 kg (553 lb.) Model 31336–292 kg (643 lb)



**Figure 5**

1. PTO shaft
2. Bolts and locknuts
3. Gear case
4. Roll pin

2. Secure them with a roll pin.
3. Tighten the bolts and nuts.

## Attachments/Accessories

A selection of Toro approved attachments and accessories is available for use with the machine to enhance and expand its capabilities. Contact your Authorized Service Dealer or Distributor or go to [www.Toro.com](http://www.Toro.com) for a list of all approved attachments and accessories.

# 5

## Greasing the Machine

### No Parts Required

### Procedure

Before operating the machine, it must be greased to ensure proper lubricating characteristics; refer to Greasing the Bearings and Bushings. Failure to properly grease the machine will result in premature failure of critical parts.

# Operation

**Note:** Determine the left and right sides of the machine from the normal operating position.

## ⚠ CAUTION

If you leave the key in the ignition switch, someone could accidentally start the engine and seriously injure you or other bystanders.

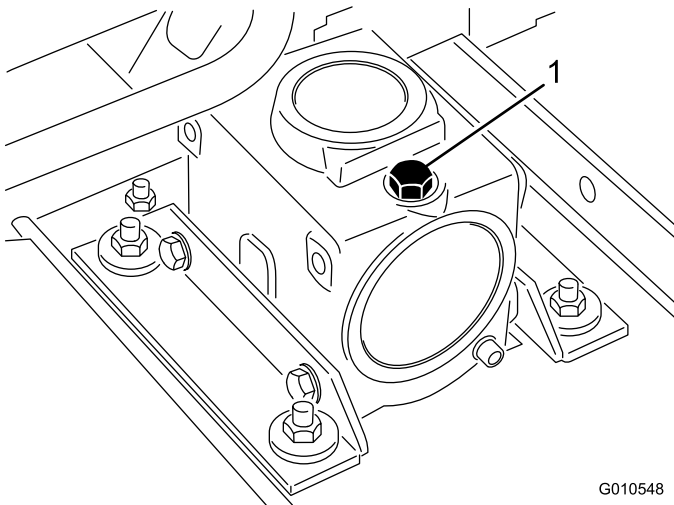
Remove the key from the ignition before you do any maintenance.

## Checking the Lubricant in the Gear Box

**Service Interval:** Every 50 hours

The gear box is designed to operate on SAE 80–90 wt. gear lube. Although the gear box is shipped with lubricant from the factory, check the level before operating the cutting unit. The gear box capacity is 283 ml (12 oz.).

1. Position the machine and cutting unit on a level surface.
2. Remove the dipstick/fill plug from the top of the gear box (Figure 6) and make sure that the lubricant is between the marks on the dipstick. If the lubricant level is low, add enough lubricant until the level is between the marks.



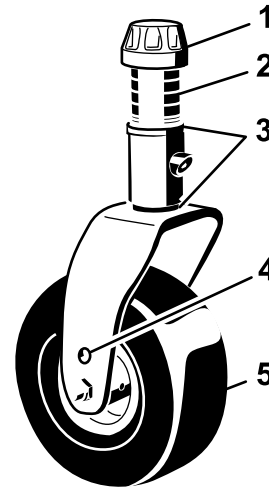
**Figure 6**

1. Dipstick/fill plug

## Adjusting the Height-of-Cut

The height-of-cut is adjustable from 25 to 127 mm (1 to 5 inches) in 13 mm (1/2 inch) increments. To adjust the height-of-cut, position the castor wheel axles in the upper or lower holes of the castor forks and add or remove an equal number of spacers from the castor forks.

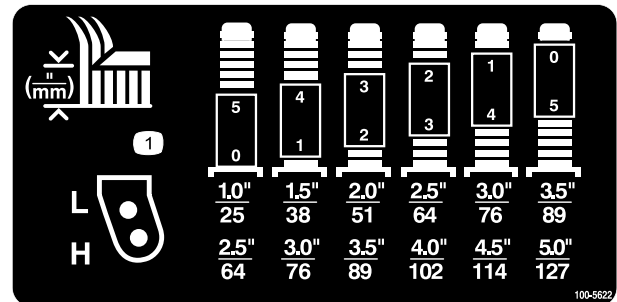
1. Start the engine and raise the cutting unit off the floor so that the height-of-cut can be changed. Stop the engine and remove the key after the cutting unit is raised.
2. Position the castor wheel axles in the same holes in all castor forks. Refer to Figure 7, Figure 8 and Figure 9 to determine the correct holes for the setting.



G008866

**Figure 7**

1. Tensioning cap
2. Spacers
3. Shims
4. Axle mounting holes
5. Castor Wheel



**Figure 8**

**Note:** When operating in 64 mm (2–1/2 inch) height of cut or higher, the axle bolt must be installed in the lower castor fork hole to prevent grass buildup between the wheel and the fork. When operating in height of cuts lower than 64 mm (2–1/2 inches) and grass buildup is detected, reverse the machines direction to pull any clippings away from the wheel/fork area.

## Front Castor Wheels

1. Remove the tensioning cap from the spindle shaft (Figure 7) and slide the spindle out of the castor arm. Put the 2 shims (1/8 inch) onto the spindle shaft as they were originally installed. These shims are required to achieve a level across the entire width of the cutting units. Slide the appropriate number of 1/2 inch spacers onto the spindle shaft to get the desired height-of-cut; then slide the washer onto the shaft.

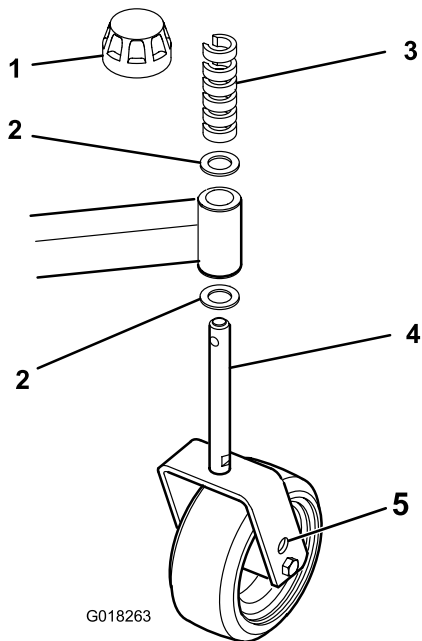
Refer to Figure 8 to determine the combinations of spacers for the setting.

2. Push the castor spindle through the castor arm. Install the shims (as they were originally installed) and the remaining spacers onto the spindle shaft. Install the tensioning cap to secure the assembly.

**Note:** When using 25 mm (1 inch), 38 mm (1-1/2 inch), or occasionally 51 mm (2 inch) height-of-cut, move the skids and roller to the highest holes.

## Rear Castor Wheels

1. Remove the tensioning cap from the spindle shaft (Figure 9).



**Figure 9**

- |                       |                        |
|-----------------------|------------------------|
| 1. Tensioning cap     | 4. Castor Wheel        |
| 2. Shims              | 5. Axle mounting holes |
| 3. "C" Shaped spacers |                        |

**Note:** The rear castor fork assembly does not need to be removed from the castor arm to change the height-of-cut.

2. Remove or add "C" shaped spacers at the narrow portion of the spindle shaft, below the castor arm, to get the desired height-of-cut. Make sure that the shims, not the spacers, contact the top and bottom of the castor arm.

3. Install the tensioning cap to secure the assembly.
4. Ensure that all four castor wheels are set at the same height-of-cut.

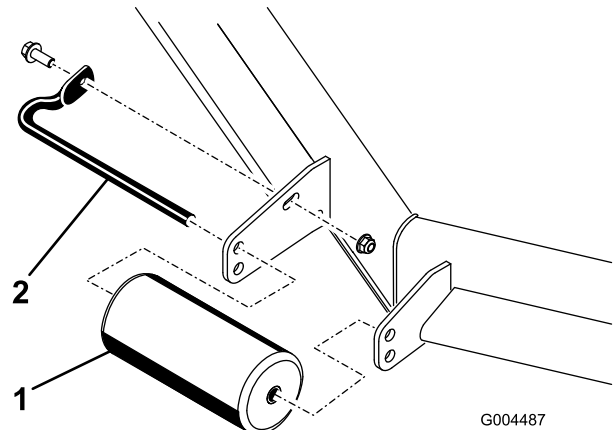
**Note:** When using 25 mm (1 inch), 38 mm (1-1/2 inch), or occasionally 51 mm (2 inch) height-of-cut, move the skids and roller to the highest holes.

## Adjusting the Rollers

**Note:** If the cutting unit is to be used in the 25 or 38 mm (1 or 1-1/2 inch) height-of-cut setting, the cutting unit rollers must be repositioned in the top bracket holes.

To adjust the front rollers (Figure 10).

1. Remove the screw and nut securing the roller shaft to the deck bracket.

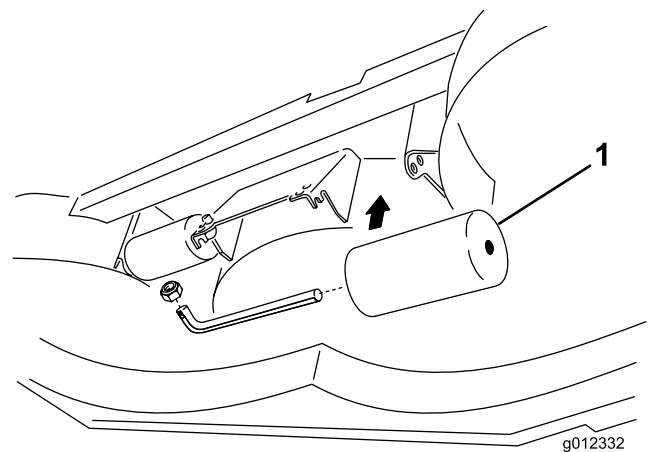


**Figure 10**

- |           |                 |
|-----------|-----------------|
| 1. Roller | 2. Roller shaft |
|-----------|-----------------|

2. Slide the shaft out of the lower bracket holes, align the roller with the top holes, and install the shaft.
3. Install the screw and nut to secure the assemblies.

To adjust the rear (internal) rollers (Figure 11)



**Figure 11**

- |                     |
|---------------------|
| 1. Internal rollers |
|---------------------|

## Adjusting the Skids

The skids should be mounted in the lower position when operating in height of cuts greater than 64 mm (2-1/2 inches) and in the higher position when operating in height of cuts lower than 64 mm (2-1/2 inches).

Adjust the skids by removing the flange bolt and nuts, positioning them as desired, and installing the fasteners (Figure 12).

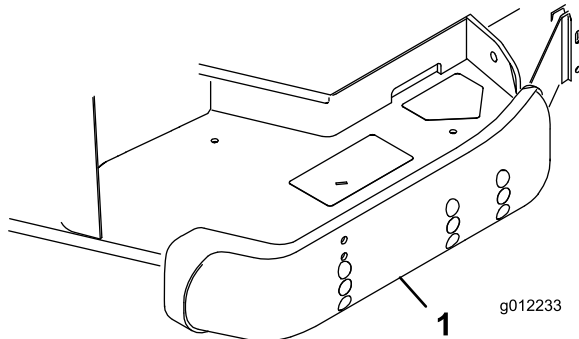


Figure 12

1. Skid

## Adjusting the Anti-Scalp Rollers

Whenever you change the height-of-cut, it is recommended to adjust the height of the anti-scalp rollers.

1. After adjusting the height-of-cut, adjust the rollers by removing the flange nut, bushing, spacer, and bolt (Figure 13).

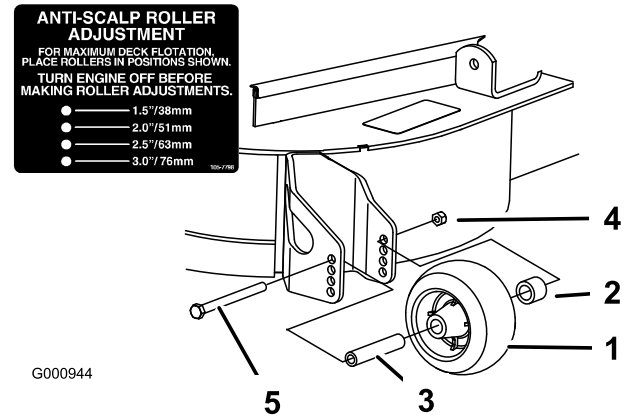


Figure 13

1. Anti-scalp roller
2. Spacer
3. Bushing
4. Flange Nut
5. Bolt

2. Select a hole so the anti-scalp roller is positioned to the nearest corresponding height-of-cut desired.
3. Install the flange nut, bushing, spacer, and bolt. Torque to 54-61 N-m (40-45 ft-lb) (Figure 13).

## Adjusting the Flow Baffle (Model 31336 only)

The mower discharge flow can be adjusted for different types of mowing conditions. Position the cam locks and baffle to give the best quality of cut.

1. To adjust the cam locks, swing the lever up to loosen the cam lock (Figure 14).
2. Adjust the baffle and cam locks in the slots to the desired discharge flow.

- Swing the lever back over to tighten the baffle and cam locks (Figure 14).
- If the cam locks do not lock the baffle into place or it is too tight, loosen the lever and then rotate the cam lock. Adjust the cam lock until the desired locking pressure is achieved.

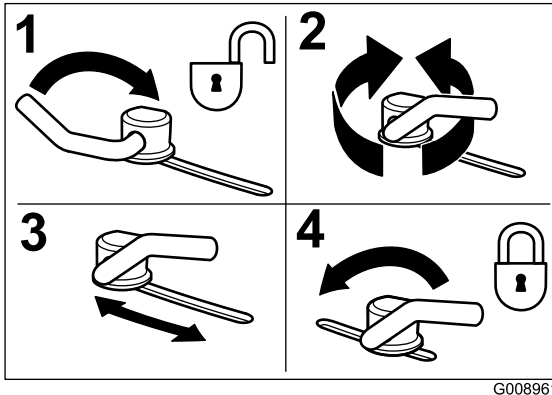


Figure 14

- Unlock lever
- Rotate the cam lock to increase or decrease locking pressure
- Position the baffle
- Lock lever

## Positioning the Flow Baffle (Model 31336 only)

The following figures are only recommendations for use. Adjustments will vary by grass type, moisture content, and height of grass.

**Note:** If the engine power draws down and the mower ground speed is the same, open up the baffle.

### Position A

This is the full rear position. The suggested use for this position is as follows.

- Use for short, light grass mowing conditions.
- Use in dry conditions.
- For smaller grass clippings.
- Propels grass clippings farther away from the mower.

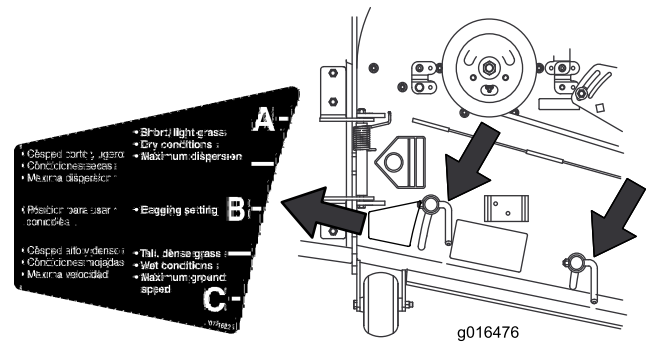


Figure 15

### Position B

Use this position when bagging. Always align it with the blower opening.

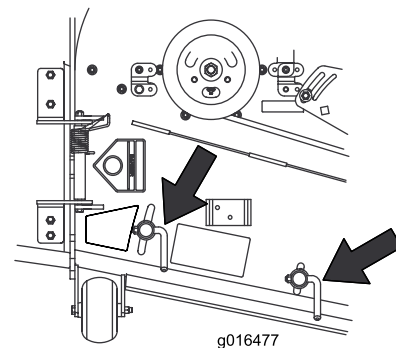


Figure 16

### Position C

This is the full open position. The suggested use for this position is as follows.

- Use in tall, dense grass mowing conditions.
- Use in wet conditions.
- Lowers the engine power consumption.
- Allows increased ground speed in heavy conditions.

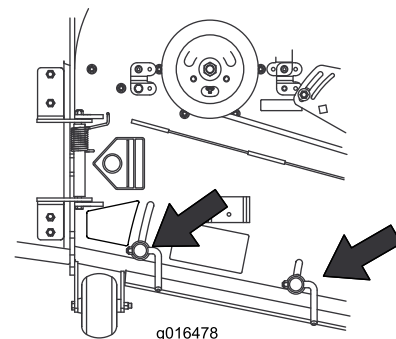


Figure 17

# Adjusting the Cutting Unit Pitch

Cutting unit pitch is the difference in height-of-cut from the front of the blade plane to the back of the blade plane. Toro recommends a blade pitch of 8 mm ( 5/16 inch). That is the back of the blade plane is 8 mm ( 5/16 inch) higher than the front.

1. Position the machine on a level surface on the shop floor.
2. Set the cutting unit to the desired height-of-cut.
3. Rotate 1 blade so that it points straight forward.
4. Using a short ruler, measure from the floor to the front tip of the blade. Rotate the blade tip to the rear and measure from the floor to the tip of the blade.
5. Subtract the front dimension from the rear dimension to calculate the blade pitch.
6. Adjust the shims, on the front or rear castor arms, to attain the required cutting unit pitch (Figure 18).

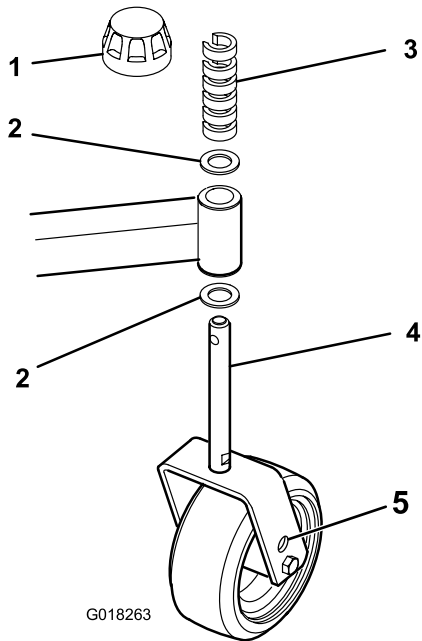


Figure 18

- |                       |                        |
|-----------------------|------------------------|
| 1. Tensioning cap     | 4. Castor Wheel        |
| 2. Shims              | 5. Axle mounting holes |
| 3. "C" Shaped spacers |                        |

2. Check and adjust front and rear tractor tire pressure to 138 kPa (20 psi).
3. Check and adjust all castor tire pressures to 345 kPa (50 psi).
4. Check for bent blades; refer to Checking for a Bent Blade.
5. Cut grass in a test area to determine if all cutting units are cutting at the same height.
6. If cutting unit adjustments are still needed, find a flat surface using a 2 m (6 foot) or longer straight edge.
7. To ease measuring blade plane, raise the height of cut to the highest position; refer to Adjusting the Height of Cut.
8. Lower the cutting unit onto the flat surface. Remove the covers from the top of the cutting units.
9. Rotate the blade on each spindle until the ends face forward and backward.
10. Measure from the floor to the front tip of the cutting edge.
11. Adjust the shims on the castor fork(s) to match the height of cut to decal; refer to Adjusting the Height of Cut.

## Using the Side Discharge (Model 31336 only)

The mower has a hinged grass deflector that disperses clippings to the side and down toward the turf.

### **⚠ DANGER**

Without a grass deflector, discharge cover, or complete grass catcher assembly mounted in place, you and others are exposed to blade contact and thrown debris. Contact with rotating mower blade(s) and thrown debris will cause injury or death.

- Never remove the grass deflector from the mower because the grass deflector routes material down toward the turf. If the grass deflector is ever damaged, replace it immediately.
- Never put your hands or feet under the mower.
- Never try to clear the discharge area or mower blades unless you move the power take off (blade control switch (PTO) to the off position, rotate the ignition key to off and remove the key.
- Make sure the grass deflector is in the down position.

## Correcting Cutting Unit Mismatch

Due to differences in grass conditions and the counterbalance setting of the traction unit, it is advised that grass be cut and appearance checked before formal cutting is started.

1. Set the cutting unit to the desired height of cut; refer to Adjusting the Height of Cut.

# Operating Tips

## Mow When Grass is Dry

Mow either in the late morning to avoid the dew, which causes grass clumping, or in late afternoon to avoid the damage that can be caused by direct sunlight on the sensitive, freshly mowed grass.

## Select the Proper Height-of-Cut Setting to Suit Conditions

Remove approximately 25 mm (1 inch) or no more than 1/3 of the grass blade when cutting. In exceptionally lush and dense grass, you may have to raise the height-of-cut to the next setting.

## Mow at Proper Intervals

Under most normal conditions you will need to mow approximately every 4–5 days. But remember, grass grows at different rates at different times. This means that in order to maintain the same height-of-cut, which is a good practice, you will need to cut more frequently in early spring; as the grass growth rate slows in mid summer, cut only every 8–10 days. If you are unable to mow for an extended period due to weather conditions or other reasons, mow first with the height-of-cut at a high level; then mow again 2–3 days later with a lower height setting.

## Always Mow with Sharp Blades

A sharp blade cuts cleanly and without tearing or shredding the grass blades like a dull blade. Tearing and shredding causes the grass to turn brown at the edges which impairs growth and increases susceptibility to diseases.

## After Operating

To ensure optimum performance, clean the underside of the mower housing after each use. If residue is allowed to build up in the mower housing, cutting performance will decrease.

## Cutting Unit Pitch

We recommend a blade pitch of 8 mm (5/16 inch). A pitch larger than 8 mm (5/16 inch) will result in less power required, larger clippings, and a poorer quality of cut. A pitch less than 8 mm (5/16 inch) will result in more power required, smaller clippings and a better quality of cut.

# Maintenance

## Recommended Maintenance Schedule(s)

Maintenance Service Interval	Maintenance Procedure
After the first 2 hours	<ul style="list-style-type: none"><li>• Tighten the castor wheel nuts</li></ul>
After the first 10 hours	<ul style="list-style-type: none"><li>• Tighten the castor wheel nuts</li><li>• Torque the blade bolts</li></ul>
Before each use or daily	<ul style="list-style-type: none"><li>• Lubricate the castor arm bushings</li><li>• Lubricate the castor wheel bearings</li><li>• Check the blades</li></ul>
Every 50 hours	<ul style="list-style-type: none"><li>• Check the gear box lubricant</li><li>• Lubricate the grease fittings</li><li>• Tighten the castor wheel nuts</li><li>• Torque the blade bolts</li><li>• Check the blade drive belt adjustment</li><li>• Clean under the cutting unit belt covers</li></ul>
Every 400 hours	<ul style="list-style-type: none"><li>• Change the gear box lubricant</li></ul>

### **⚠ CAUTION**

If you leave the key in the ignition switch, someone could accidentally start the engine and seriously injure you or other bystanders.

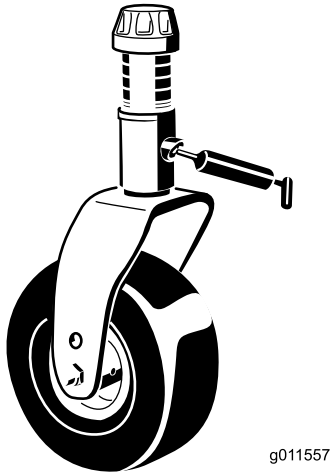
Remove the key from the ignition switch before you do any maintenance.

# Lubrication

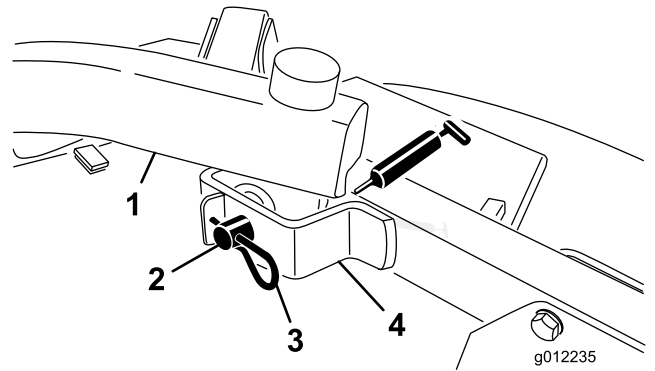
**Service Interval:** Every 50 hours

The machine has grease fittings that must be lubricated regularly with No. 2 General Purpose Lithium Base Grease. If the machine is operated under normal conditions, lubricate all bearings and bushings after every 50 hours of operation or immediately after every washing.

1. Lubricate the following areas:
  - Castor fork shaft bushings (4)(Figure 19)

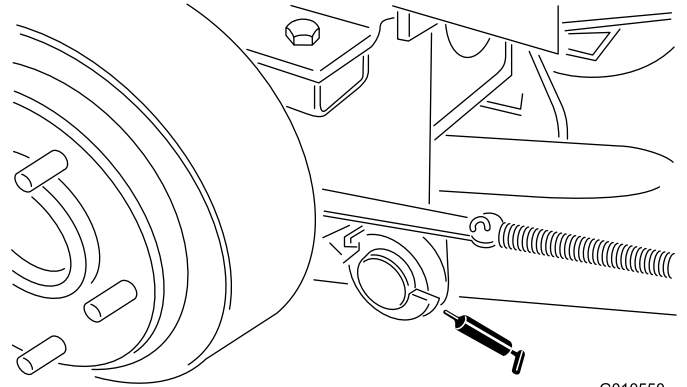


**Figure 19**



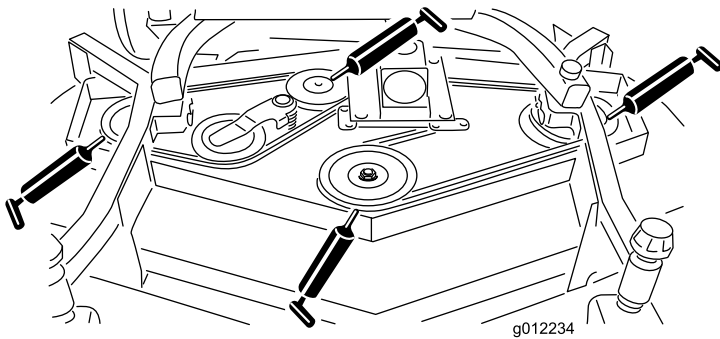
**Figure 21**

- Lift arm pivots, rear (2) (Figure 22)



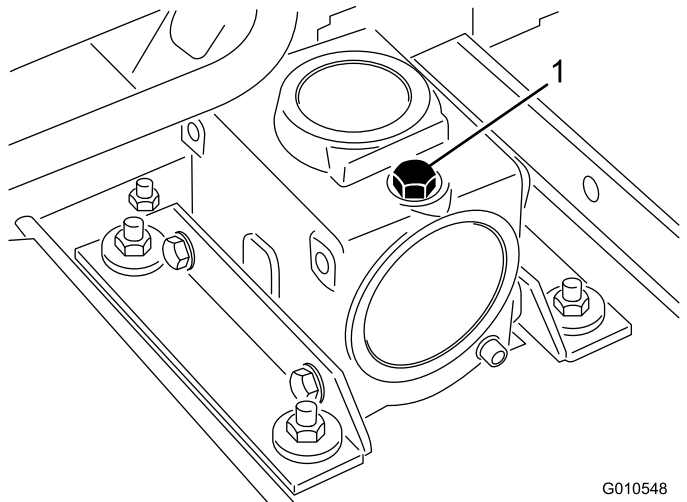
**Figure 22**

- Spindle shaft bearings (3) (located under the pulley) (Figure 20)



**Figure 20**

2. Position the machine and cutting unit on a level surface and lower the cutting unit. Remove the dipstick/fill plug from the top of the gear box (Figure 23) and make sure that the lubricant is between the marks on the dipstick. If the lubricant level is low, add SAE 80-90 wt. gear lube until the level is between the marks. The gear box capacity is 12 ounces (283 ml).



**Figure 23**

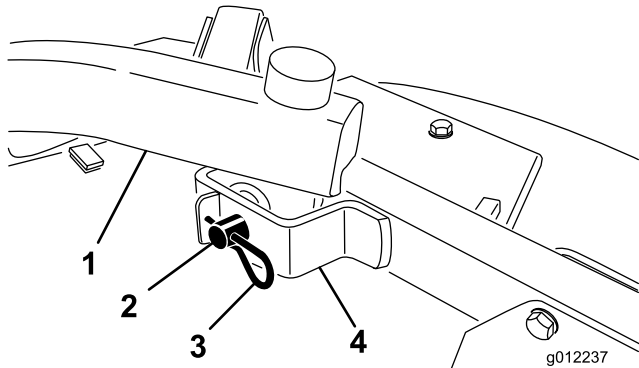
1. Dipstick/fill plug

## Pre Maintenance

**Important:** The fasteners on the covers of this machine are designed to remain on the cover after removal. Loosen all of the fasteners on each cover a few turns so that the cover is loose but still attached, then go back and loosen them until the cover comes free. This will prevent you from accidentally stripping the bolts free of the retainers.

## Separating the Cutting Unit from the Traction Unit

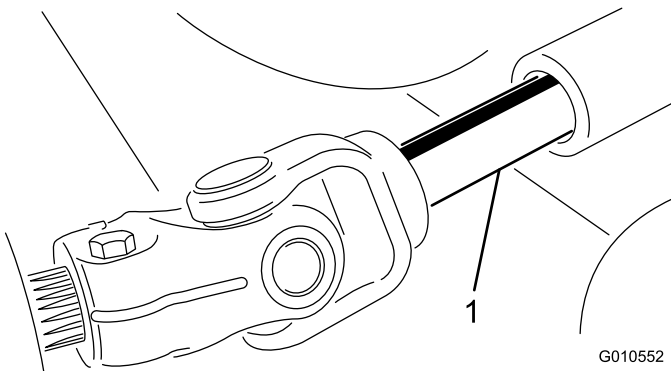
1. Position the machine on level surface, lower the cutting unit to the floor, move the lift lever to the Float position, shut the engine off, and engage the parking brake.
2. Remove the hair pin cotters and clevis pins securing the lift arms to the castor arm brackets (Figure 24).



**Figure 24**

- |               |                       |
|---------------|-----------------------|
| 1. Lift arm   | 3. Hairpin cotter     |
| 2. Clevis pin | 4. Castor arm bracket |

3. Roll the cutting unit away from the traction unit, separating the male and female sections of the PTO shaft (Figure 25).



**Figure 25**

- |              |
|--------------|
| 1. PTO shaft |
|--------------|

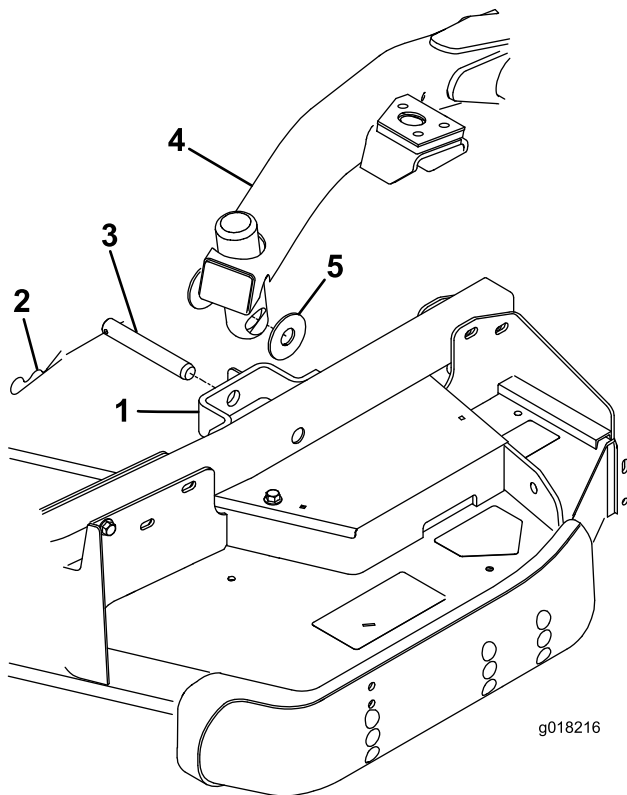
## **⚠ DANGER**

If the engine is started and the PTO shaft is allowed to rotate, serious injury could result.

Do not start the engine and engage the PTO lever when the PTO shaft is not connected to the gear box on the cutting unit.

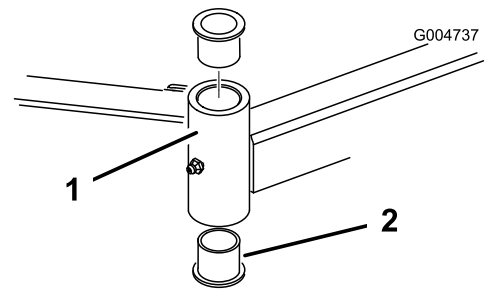
## Mounting the Cutting Unit to the Traction Unit

1. Position the machine on a level surface and shut the engine off.
2. Move the cutting unit into position in front of the traction unit.
3. Slide the male PTO shaft into the female PTO shaft (Figure 25).
4. Press the lift switch forward to the Float position. Push a lift arm down until the holes in the lift arm line up with the holes in the castor arm bracket and the height of cut rod can be inserted into the lift arm pads (Figure 26).
5. Secure the lift arm to the castor arm with (2) thrust washers, a clevis pin and a hair pin cotter. Position the thrust washers between the lift arm and the castor arm bracket (Figure 26). Insert end of cotter pin into the slot in the castor arm tab to retain cotter pin.
6. Repeat the procedure on the opposite lift arm.
7. Start the traction unit and raise the cutting unit.



**Figure 26**

- |                       |                  |
|-----------------------|------------------|
| 1. Castor arm bracket | 4. Lift arm      |
| 2. Hairpin cotter     | 5. Thrust washer |
| 3. Clevis pin         |                  |



**Figure 27**

- |                    |             |
|--------------------|-------------|
| 1. Castor arm tube | 2. Bushings |
|--------------------|-------------|

- Apply grease to the inside and outside of the new bushings. Using a hammer and flat plate, drive the bushings into the mounting tube.
- Inspect the castor spindle for wear and replace it if damaged.
- Push the castor spindle through the bushings and mounting tube. Slide the thrust washer and spacer(s) onto the spindle. Install the tensioning cap on the castor spindle to retain all parts in place.

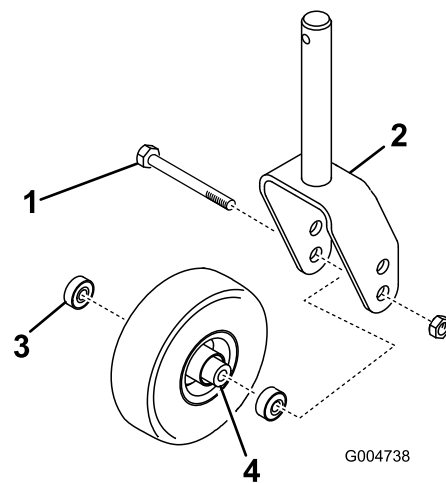
## Servicing the Bushings in the Castor Arms

The castor arms have bushings pressed into the top and bottom of the tube and after many hours of operation, the bushings will wear. To check the bushings, move the castor fork back and forth and from side to side. If the castor spindle is loose inside the bushings, the bushings are worn and must be replaced.

- Raise the cutting unit so that the wheels are off of the floor. Block the cutting unit so that it cannot accidentally fall.
- Remove the tensioning cap, spacer(s), and thrust washer from the top of the castor spindle.
- Pull the castor spindle out of the mounting tube. Allow the thrust washer and spacer(s) to remain on the bottom of the spindle.
- Insert a pin punch into the top or bottom of the mounting tube and drive the bushing out of the tube (Figure 27). Also drive the other bushing out of the tube. Clean the inside of the tubes to remove dirt.

## Servicing the Castor Wheels and Bearings

- Remove the locknut from the bolt holding the castor wheel assembly between the castor fork (Figure 28). Grasp the castor wheel and slide the bolt out of the fork or pivot arm.



**Figure 28**

- |                 |                   |
|-----------------|-------------------|
| 1. Castor wheel | 3. Bearing (2)    |
| 2. Castor fork  | 4. Bearing spacer |

- Remove the bearing from the wheel hub and allow the bearing spacer to fall out (Figure 28). Remove the bearing from the opposite side of the wheel hub.
- Check the bearings, spacer, and inside of the wheel hub for wear. Replace any damaged parts.

- To assemble the castor wheel, push the bearing into the wheel hub. When installing the bearings, press on the outer race of the bearing.
- Slide the bearing spacer into the wheel hub. Push the other bearing into the open end of the wheel hub to captivate the bearing spacer inside the wheel hub.
- Install the castor wheel assembly between the castor fork and secure it in place with the bolt and locknut.

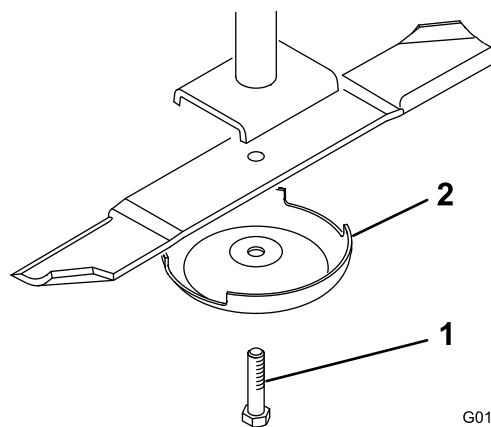


Figure 30

G010555

- Blade bolt
- Anti-scalp cup

## Checking for a Bent Blade

- Position the machine on a level surface. Raise the cutting unit, engage the parking brake, put the traction pedal in neutral, put the PTO lever in the Off position, stop the engine, and remove the ignition key. Block the cutting unit to prevent it from accidentally falling.
- Rotate the blade until the ends face forward and backward. Measure from the inside of the cutting unit to the cutting edge at the front of the blade (Figure 29), and remember this dimension.



Figure 29

G010549

- Rotate the opposite end of the blade forward. Measure between the cutting unit and cutting edge of the blade at the same position as in step 2. The difference between the dimensions obtained in steps 2 and 3 must not exceed 3 mm (1/8 inch). If the dimension exceeds 3 mm (1/8 inch), replace the blade because it is bent; refer to Removing the Cutting Blade.

## Removing and Installing the Blade(s)

The blade must be replaced if a solid object is hit, the blade is out-of-balance, worn, or bent. Always use genuine Toro replacement blades to ensure safety and optimum performance. Never use blades made by other manufacturers because they could be dangerous.

- Raise the cutting unit to the highest position, engage the parking brake, stop the engine, and remove the ignition key. Block the cutting unit to prevent it from accidentally falling.
- Grasp the end of the blade using a rag or thickly padded glove. Remove the blade bolt, anti-scalp cup, and blade from the spindle shaft (Figure 30).

- Install the blade-sail facing toward the cutting unit-with the anti-scalp cup and blade bolt. Tighten the blade bolt to 115-149 N-m (85-110 ft-lb).

**Important:** The curved part of the blade must be pointing toward the inside of the cutting unit to ensure proper cutting.

# Inspecting and Sharpening the Blade(s)

**Service Interval:** Before each use or daily

Every 50 hours

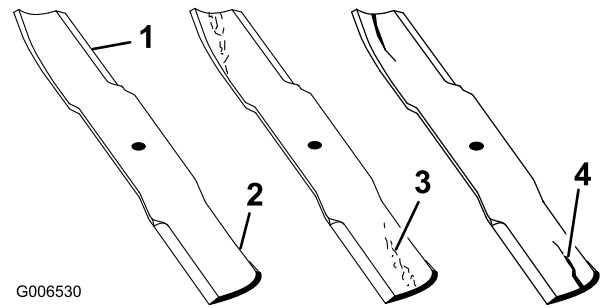
## **⚠ DANGER**

A worn or damaged blade can break, and a piece of the blade could be thrown into the operator's or bystander's area, resulting in serious personal injury or death.

- Inspect the blade periodically for wear or damage.
- Do not try to straighten a blade that is bent.
- Never weld a broken or cracked blade.
- Replace a worn or damaged blade with a new Toro blade to ensure continued safety certification of the product.

Two areas must be considered when checking and servicing the cutting blade: the sail and the cutting edge. Both cutting edges and the sail, which is the turned up portion opposite the cutting edge, contribute to a good quality-of-cut. The sail is important because it pulls grass up straight, thereby producing an even cut. However, the sail will gradually wear down during operation, and this condition is normal. As the sail wears down, the quality-of-cut will degrade somewhat, although the cutting edges are sharp. The cutting edge of the blade must be sharp so that the grass is cut rather than torn. A dull cutting edge is evident when the tips of the grass appear brown and shredded. Sharpen the cutting edges to correct this condition.

1. Position the machine on a level surface. Raise the cutting unit, engage the parking brake, put the traction pedal in neutral, put the PTO lever in the Off position, stop the engine, and remove the ignition key.
2. Examine the cutting ends of the blade carefully, especially where the flat and curved parts of the blade meet (Figure 31). Since sand and abrasive material can wear away the metal that connects the flat and curved parts of the blade, check the blade before using the machine. If wear is noticed (Figure 31), replace the blade; refer to Removing the Cutting Blade.



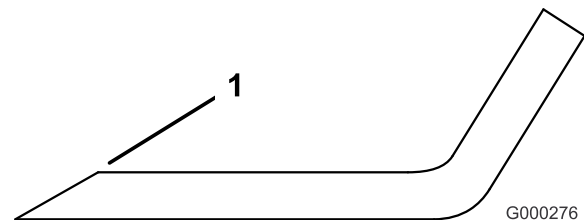
**Figure 31**

1. Cutting edge
2. Curved area/sail
3. Wear/slot forming
4. Crack

## **⚠ WARNING**

If the blade is allowed to wear, a slot will form between the sail and flat part of the blade (Figure 31). Eventually, a piece of the blade may break off and be thrown from under the housing, possibly resulting in serious injury to yourself or bystanders.

- Inspect the blade periodically for wear or damage.
  - Replace a worn or damaged blade with a new Toro blade to ensure continued safety certification of the product.
3. Examine the cutting edges of all blades. Sharpen the cutting edges if they are dull or nicked. Sharpen only the top side of the cutting edge and maintain the original cutting angle to ensure sharpness (Figure 32). The blade will remain balanced if the same amount of metal is removed from both cutting edges.



**Figure 32**

1. Sharpen at original angle

**Note:** Remove the blades and sharpen them on a grinder; refer to Removing the Cutting Blades. After sharpening the cutting edges, install the blade with the anti-scalp cup and blade bolt. The blade sails must be on top of the blade. Tighten the blade bolt to 115-149 N-m (85-110 ft-lb).

## Checking and Correcting Mismatch of Blades

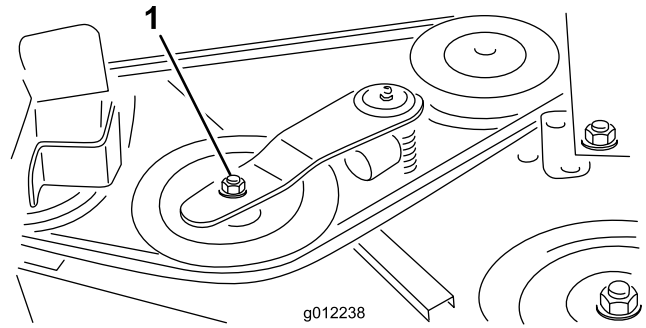
If there is mismatch between the blades, the grass will appear streaked when it is cut. This problem can be corrected by making sure that the blades are straight and all of the blades are cutting on the same plane.

1. Using a 1 meter (3 foot) long carpenters level, find a level surface on the shop floor.
  2. Raise the height-of-cut to the highest position; refer to Adjusting the Height-of-Cut.
  3. Lower the cutting unit onto the flat surface. Remove the covers from the top of the cutting unit.
  4. Rotate the blades until the ends face forward and backward. Measure from the floor to the front tip of the cutting edge. Remember this dimension. Then rotate the same blade so that the opposite end is forward, and measure again. The difference between the dimensions must not exceed 3 mm (1/8 inch). If the dimension exceeds 3 mm (1/8 inch), replace the blade because it is bent. Make sure to measure all of the blades.
  5. Compare the measurements of the outer blades with the center blade. The center blade must not be more than 10 mm (3/8 inch) lower than the outer blades. If the center blade is more than 10 mm (3/8 inch) lower than the outer blades, proceed to step 6 and add shims between the spindle housing and the bottom of the cutting unit.
  6. Remove the bolts, flat washers, lock washers, and nuts from the outer spindle in the area where the shims must be added. To raise or lower the blade, add a shim, Part No. 3256-24, between the spindle housing and the bottom of the cutting unit. Continue to check the alignment of the blades and add shims until the tips of the blades are within the required dimension.
- Important: Do not use more than three shims at any one hole location. Use decreasing numbers of shims in adjacent holes if more than one shim is added to any one hole location.**
7. Install the belt covers.

## Replacing the Drive Belt

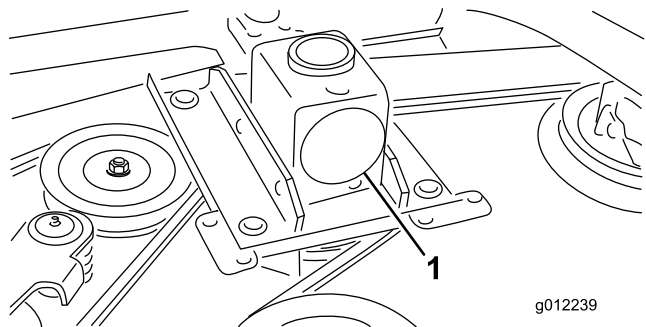
The blade drive belt, tensioned by the spring loaded idler pulley, is very durable. However, after many hours of use, the belt will show signs of wear. Signs of a worn belt are: squealing when belt is rotating, blades slipping when cutting grass, frayed edges, burn marks and cracks. Replace the belt if any of these conditions are evident.

1. Lower the cutting unit to the shop floor. Remove the belt covers from the top of the cutting unit and set the covers aside.
2. Using a torque wrench or similar tool, move the idler pulley (Figure 33) away from the drive belt to release the belt tension and allow the belt to be slipped off the gearbox pulley (Figure 34).



**Figure 33**

1. Idler pulley



**Figure 34**

1. Gearbox

3. Remove the old belt from around the spindle pulleys and idler pulley.
4. Route the new belt around the spindle pulleys and idler pulley assembly as shown in Figure 35.

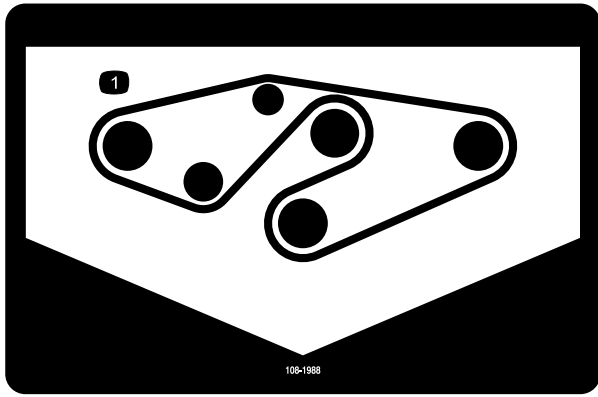


Figure 35

1. Belt routing

5. Install the belt covers.

## Replacing the Grass Deflector

### **⚠ WARNING**

An uncovered discharge opening could allow the lawn mower to throw objects in the operator's or bystander's direction and result in serious injury. Also, contact with the blade could occur.

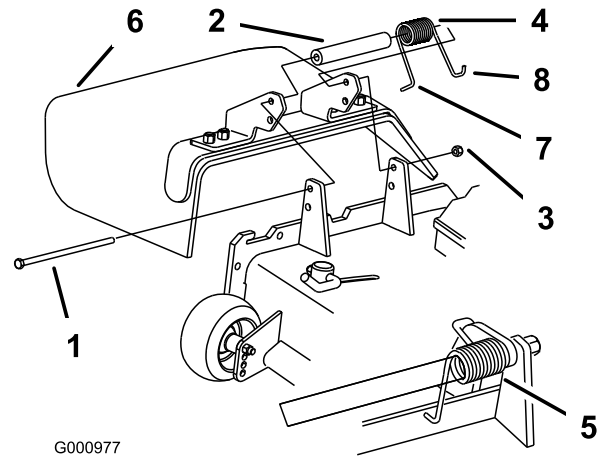
- Never operate the lawn mower unless you install a cover plate, a mulch plate, or a grass chute and catcher.
- Make sure the grass deflector is in the down position.

1. Remove the locknut, bolt, spring and spacer holding the deflector to the pivot brackets (Figure 36). Remove the damaged or worn grass deflector.
2. Place the spacer and spring onto grass deflector. Place the **L** end of spring behind deck edge.

**Note:** Make sure the **L** end of the spring is installed behind the deck edge before installing the bolt as shown in Figure 36.

3. Install the bolt and nut. Place the **J** hook end of the spring around the grass deflector (Figure 36).

**Important:** The grass deflector must be able to lower down into position. Lift the deflector up to test that it lowers into the full down position.



G000977

Figure 36

- |            |   |
|------------|---|
| 1. Bolt    | 5. Spring installed   |
| 2. Spacer  | 6. Grass Deflector  |
| 3. Locknut | 7. L end of spring, place behind deck edge before installing bolt |
| 4. Spring  | 8. J hook end of spring   |

# Declaration of Incorporation

The Toro Company, 8111 Lyndale Ave. South, Bloomington, MN, USA declares that the following unit(s) conform(s) to the directives listed, when installed in accordance with the accompanying instructions onto certain Toro models as indicated on the relevant Declarations of Conformity.

Model No.	Serial No.	Product Description	Invoice Description	General Description	Directive
31335	314000001 and Up	72in Guardian Recycler Mower	72" GUARDIAN DECK W/4 CASTORS	72in Guardian Recycler Mower	2006/42/EC, 2000/14/EC
31336	314000001 and Up	72in Side-Discharge Mower	72" SD DECK W/4 CASTORS	72in Side-Discharge Mower	2006/42/EC, 2000/14/EC

Relevant technical documentation has been compiled as required per Part B of Annex VII of 2006/42/EC.

We will undertake to transmit, in response to requests by national authorities, relevant information on this partly completed machinery. The method of transmission shall be electronic transmittal.

This machinery shall not be put into service until incorporated into approved Toro models as indicated on the associated Declaration of Conformity and in accordance with all instructions, whereby it can be declared in conformity with all relevant Directives.

Certified:



David Klis  
 Sr. Engineering Manager  
 8111 Lyndale Ave. South  
 Bloomington, MN 55420, USA  
 September 26, 2013

EU Technical Contact:

Peter Tetteroo  
 Toro Europe NV  
 B-2260 Oevel-Westerloo  
 Belgium

Tel. 0032 14 562960  
 Fax 0032 14 581911



# The Toro Total Coverage Guarantee

## A Limited Warranty

### Conditions and Products Covered

The Toro Company and its affiliate, Toro Warranty Company, pursuant to an agreement between them, jointly warrant your Toro Commercial product ("Product") to be free from defects in materials or workmanship for two years or 1500 operational hours\*, whichever occurs first. This warranty is applicable to all products with the exception of Aerators (refer to separate warranty statements for these products). Where a warrantable condition exists, we will repair the Product at no cost to you including diagnostics, labor, parts, and transportation. This warranty begins on the date the Product is delivered to the original retail purchaser.

\* Product equipped with an hour meter.

### Instructions for Obtaining Warranty Service

You are responsible for notifying the Commercial Products Distributor or Authorized Commercial Products Dealer from whom you purchased the Product as soon as you believe a warrantable condition exists. If you need help locating a Commercial Products Distributor or Authorized Dealer, or if you have questions regarding your warranty rights or responsibilities, you may contact us at:

Toro Commercial Products Service Department  
Toro Warranty Company  
8111 Lyndale Avenue South  
Bloomington, MN 55420-1196  
952-888-8801 or 800-952-2740  
E-mail: commercial.warranty@toro.com

### Owner Responsibilities

As the Product owner, you are responsible for required maintenance and adjustments stated in your *Operator's Manual*. Failure to perform required maintenance and adjustments can be grounds for disallowing a warranty claim.

### Items and Conditions Not Covered

Not all product failures or malfunctions that occur during the warranty period are defects in materials or workmanship. This warranty does not cover the following:

- Product failures which result from the use of non-Toro replacement parts, or from installation and use of add-on, or modified non-Toro branded accessories and products. A separate warranty may be provided by the manufacturer of these items.
- Product failures which result from failure to perform recommended maintenance and/or adjustments. Failure to properly maintain your Toro product per the Recommended Maintenance listed in the *Operator's Manual* can result in claims for warranty being denied.
- Product failures which result from operating the Product in an abusive, negligent, or reckless manner.
- Parts subject to consumption through use unless found to be defective. Examples of parts which are consumed, or used up, during normal Product operation include, but are not limited to, brake pads and linings, clutch linings, blades, reels, rollers and bearings (sealed or greasable), bed knives, spark plugs, castor wheels and bearings, tires, filters, belts, and certain sprayer components such as diaphragms, nozzles, and check valves, etc.
- Failures caused by outside influence. Conditions considered to be outside influence include, but are not limited to, weather, storage practices, contamination, use of unapproved fuels, coolants, lubricants, additives, fertilizers, water, or chemicals, etc.
- Failure or performance issues due to the use of fuels (e.g. gasoline, diesel, or biodiesel) that do not conform to their respective industry standards.

### Countries Other than the United States or Canada

Customers who have purchased Toro products exported from the United States or Canada should contact their Toro Distributor (Dealer) to obtain guarantee policies for your country, province, or state. If for any reason you are dissatisfied with your Distributor's service or have difficulty obtaining guarantee information, contact the Toro importer.

- Normal noise, vibration, wear and tear, and deterioration.
- Normal "wear and tear" includes, but is not limited to, damage to seats due to wear or abrasion, worn painted surfaces, scratched decals or windows, etc.

### Parts

Parts scheduled for replacement as required maintenance are warranted for the period of time up to the scheduled replacement time for that part. Parts replaced under this warranty are covered for the duration of the original product warranty and become the property of Toro. Toro will make the final decision whether to repair any existing part or assembly or replace it. Toro may use remanufactured parts for warranty repairs.

### Deep Cycle and Lithium-Ion Battery Warranty:

Deep cycle and Lithium-Ion batteries have a specified total number of kilowatt-hours they can deliver during their lifetime. Operating, recharging, and maintenance techniques can extend or reduce total battery life. As the batteries in this product are consumed, the amount of useful work between charging intervals will slowly decrease until the battery is completely worn out. Replacement of worn out batteries, due to normal consumption, is the responsibility of the product owner. Battery replacement may be required during the normal product warranty period at owner's expense. Note: (Lithium-Ion battery only): A Lithium-Ion battery has a part only prorated warranty beginning year 3 through year 5 based on the time in service and kilowatt hours used. Refer to the *Operator's Manual* for additional information.

### Maintenance is at Owner's Expense

Engine tune-up, lubrication, cleaning and polishing, replacement of filters, coolant, and completing recommended maintenance are some of the normal services Toro products require that are at the owner's expense.

### General Conditions

Repair by an Authorized Toro Distributor or Dealer is your sole remedy under this warranty.

**Neither The Toro Company nor Toro Warranty Company is liable for indirect, incidental or consequential damages in connection with the use of the Toro Products covered by this warranty, including any cost or expense of providing substitute equipment or service during reasonable periods of malfunction or non-use pending completion of repairs under this warranty. Except for the Emissions warranty referenced below, if applicable, there is no other express warranty. All implied warranties of merchantability and fitness for use are limited to the duration of this express warranty.**

Some states do not allow exclusions of incidental or consequential damages, or limitations on how long an implied warranty lasts, so the above exclusions and limitations may not apply to you. This warranty gives you specific legal rights, and you may also have other rights which vary from state to state.

### Note regarding engine warranty:

The Emissions Control System on your Product may be covered by a separate warranty meeting requirements established by the U.S. Environmental Protection Agency (EPA) and/or the California Air Resources Board (CARB). The hour limitations set forth above do not apply to the Emissions Control System Warranty. Refer to the Engine Emission Control Warranty Statement supplied with your product or contained in the engine manufacturer's documentation for details