



MODEL NO. 38025-0000001 & UP

OPERATOR'S
MANUAL

1800 POWER CURVE® SNOWTHROWER



SAFETY INSTRUCTIONS

To assure maximum safety, optimum performance, and to gain knowledge of the product, it is essential that you or any other operator of the snowthrower read and understand the contents of this manual before the motor is ever started. Pay particular attention to the safety alert symbol which means CAUTION, WARNING OR DANGER — “personal safety instruction.” Read and understand the instruction because it has to do with safety. Failure to comply with instruction may result in personal injury.

BEFORE OPERATING

1. Read and understand the contents of this manual before operating the snowthrower. Become familiar with all controls and know how to stop quickly.
2. Keep everyone, especially children and pets, away from area of operation. Never allow children to operate snowthrower. Always direct discharge chute away from people.
3. Inspect area thoroughly where snowthrower will be used. Remove doormats, sleds, boards, sticks, wire, and any other foreign objects which might be picked up and thrown by the snowthrower.
4. Keep all shields and safety devices in place. If a shield, safety device, or decal is illegible or damaged, repair or replace it before beginning operation. Also, tighten any loose nuts, bolts, or screws.
5. Wear adequate winter clothing and rubber boots that will assure proper footing on slippery surfaces. Do not wear loose-fitting clothing that could possibly get caught in moving parts.
6. Do not use snowthrower on gravel or crushed rock surfaces. Flying debris may cause damage or personal injury.
7. **WARNING** - To prevent electric shock, use only an extension cord suit-

able for outdoor use in cold temperatures (16 gauge minimum). Replace a damaged extension cord immediately.

8. To prevent disconnection of snowthrower cord from extension cord during operation, tie extension cord to upper metal tube before connecting to snowthrower cord; refer to page 4, Figure 4 for proper procedures.
9. The use of attachments or accessories on this snowthrower may increase the risk of injury.

WHILE OPERATING

10. Keep people and pets a safe distance away from the snowthrower and area of operation.
11. Avoid accidental starting. Don't carry plugged in snowthrower with hand on control bar. Keep away from control bar while plugging in cord.
12. If the extension cord is damaged in any manner while plugged in, pull extension cord from wall receptacle.
13. Do not abuse extension cord. Never carry snowthrower by cord or pull sharply on cord to disconnect from receptacle. Keep cord away from heat, oil, and sharp edges.
14. Always keep extension cord away from rotating parts to prevent damage and electric shock.

SAFETY INSTRUCTIONS

15. Operate the snowthrower only when there is good visibility or light. Always maintain secure footing and balance, and keep a firm grip on the handle. **DO NOT USE SNOWTHROWER ON ROOF.**

16. Be attentive when using the snowthrower, and stay alert for holes in the terrain and other hidden hazards.

17. **STAY AWAY FROM DISCHARGE OPENING WHILE OPERATING THE SNOWTHROWER.** Keep face, hands, feet, and any other part of your body or clothing away from concealed, moving, or rotating parts.

18. Never operate snowthrower near bystanders, glass enclosures, automobiles and trucks, window wells or a drop-off without proper adjustment of the snow discharge angle; refer to page 5, item 2 for correct operating procedure.

19. Clear snow from slopes by going up and down, never across the face. Use caution when changing directions. Never clear snow from steep slopes.

20. Operation of the snowthrower in the hand-held position (wheels off the ground) is unsafe except when used in accordance with special instructions in the Operator's Manual. See page 5, items 5 and 6.

21. When using the secondary handle, always turn chute in the opposite direction from where you are standing.

22. Forcing the chute deflector over the stops will cause snow and debris to spray in the operator's zone.

23. **DO NOT OVERLOAD THE SNOWTHROWER BY CLEARING SNOW AT TOO FAST A RATE. LET THE UNIT DO THE WORK.**

24. If a solid object is hit or snowthrower vibrates abnormally, stop snowthrower and wait for all movement to stop. Disconnect extension cord and check snowthrower immediately for possible damage, an obstruction, debris in rotor, or loose parts. Vibration is generally a sign of trouble. Repair

any damage before operating snowthrower again.

25. Before adjusting, cleaning, repairing, or inspecting the snowthrower, or before unclogging the discharge chute, stop snowthrower by releasing the control bar and wait for all moving parts to stop. Also, disconnect cord from receptacle to prevent accidental starting.

26. When through using snowthrower, let it run for a few minutes so ice does not freeze moving parts solid.

27. Disconnect cord from extension cord receptacle, lock cord, and remove key from handle if snowthrower will be left unattended.

MAINTAINING SNOWTHROWER

28. Perform only those maintenance instructions described in this manual. Disconnect cord from receptacle before performing maintenance procedures to prevent the possibility of accidental starting. If major repairs are ever needed, contact your local Authorized TORO Service Dealer or TORO Service Center for assistance.

29. Keep the snowthrower in safe operating condition by keeping nuts, bolts, and screws tight. Check all fasteners frequently to assure they are tight.

30. Store snowthrower indoors when not in use in a dry, locked-up place out of reach of children. Remove extension cord from snowthrower and store with snowthrower to prevent misplacement. Lock snowthrower cord and remove key from handle. Store key in a memorable place.

31. At the time of manufacture, the snowthrower conformed to and exceeded safety standards in effect for snowthrowers. Therefore, to assure optimum performance and safety, purchase genuine TORO replacement parts and accessories to keep the TORO all TORO. **NEVER USE "WILL FIT" REPLACEMENT PARTS AND ACCESSORIES.** The TORO logo assures genuineness.

SAFETY DECALS

Safety decals and instructions are easily visible to the operator and are located near any area of potential danger. Replace any decal that is damaged.

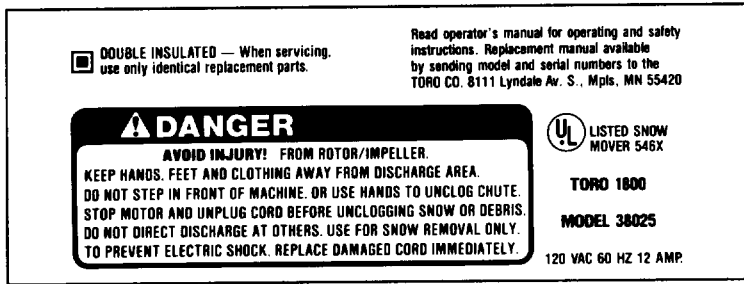

On Rear of Shroud
(Part No. 73-0450)



On Rear of Shroud
(Part No. 73-0460)

TABLE OF CONTENTS

| | Page | | |
|-------------------------|------|------------------------|------|
| Set-Up Instructions | 3-4 | Replacing Belts | 8-10 |
| Operating Instructions | 4-6 | Storing Snowthrower | 10 |
| Maintenance | 6-10 | Toro Service Support | 10 |
| Lubricating Snowthrower | 6 | Product Identification | 10 |
| Replacing Scraper | 6 | Maintenance Record | 11 |
| Replacing Rotor | 7-8 | The Toro Promise | |

SET-UP INSTRUCTIONS

INSTALL UPPER HANDLE AND CHUTE CRANK

1. Stand snowthrower on wheels and position upper handle to prepare for handle assembly. Inspect the open internal wiring. If damaged do not assemble. Contact your TORO Service Dealer.

Note: Use care so electrical cord will not be damaged during assembly.

2. Carefully insert upper tubing into lower tubing until mounting holes are aligned (Fig. 1).

3. Place the mounting plate over the tubing (Fig. 2). Align mounting plate holes with upper and lower tubing holes. Insert end of chute crank through hole in shroud. Rotate crank

until flattened end aligns with large slot in gear. Firmly push chute crank into gear until it snaps into place (Fig. 2).

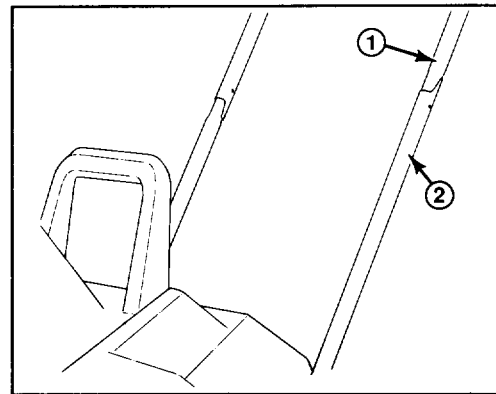

Figure 1

1. Upper tubing

2. Lower tubing

SET-UP INSTRUCTIONS

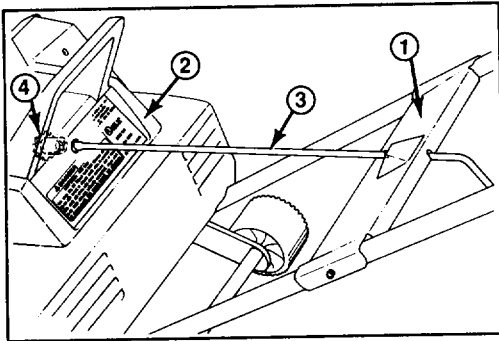

Figure 2

- | | |
|-------------------|----------------|
| 1. Mounting plate | 3. Chute crank |
| 2. Shroud | 4. Gear |

4. Secure upper and lower tubing and mounting plate together with (2) machine screws and locknuts. Position screw heads on the outside of the mounting plate. Be careful not to damage the electrical wiring when inserting screws. If hole is blocked, use a 1/8" punch to carefully route electrical wiring away from aligned holes.

INSTALL DISCHARGE CHUTE (Fig. 3)

1. Position chute deflector onto discharge chute, aligning mounting holes. On each side of chute, insert a rubber washer between deflector and chute while maintaining hole alignment.

2. Secure deflector to discharge chute with (2) carriage bolts, metal washers, and locknuts. Make sure the square shoulders on the carriage bolts align with the square on the chute. Position bolt heads inside chute and metal washers to the outside of deflector as shown in Figure 3. **DO NOT OVERTIGHTEN BOLTS.**

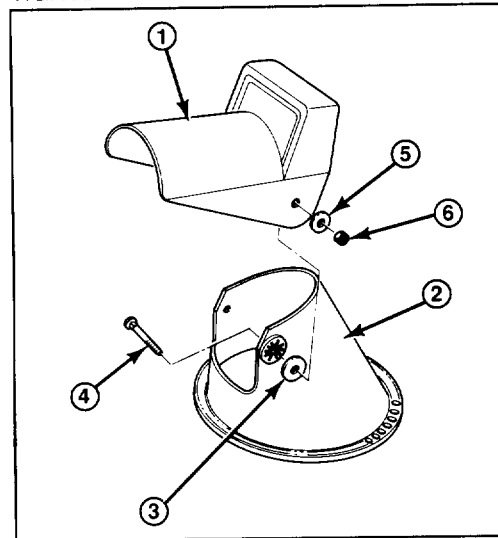

Figure 3

- | | |
|--------------------|------------------|
| 1. Chute deflector | 4. Carriage bolt |
| 2. Chute | 5. Metal washer |
| 3. Rubber washer | 6. Locknut |

OPERATING INSTRUCTIONS

BEFORE OPERATING

1. Check the condition of the unit, and make sure the rotor turns freely.
2. Before connecting the extension cord to the snowthrower cord, tie the extension cord to the upper metal tube of the snowthrower as shown in Fig. 4. This helps prevent cord separation during operation.

3. To unlock the snowthrower cord, turn key in lock on primary handle.

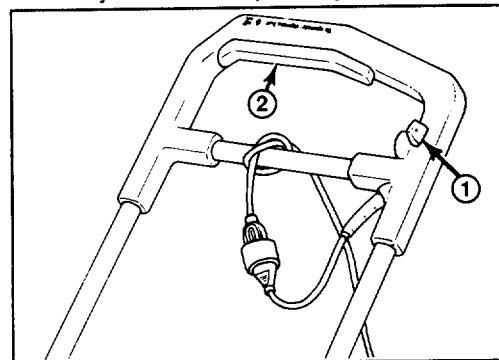



Figure 4

- | | |
|--------|----------------|
| 1. Key | 2. Control bar |
|--------|----------------|

| |
|---|
|  CAUTION |
| <p>Use only an extension cord suitable for outdoor use in cold temperatures (16 gauge minimum).</p> |

OPERATING INSTRUCTIONS

NOTE: The key has nothing to do with the operation of the snowthrower. It is a safety device for locking the cord to prevent unauthorized use.

STARTING/STOPPING

To start rotor, squeeze the control bar. To stop rotor, release the control bar (Fig. 4).

OPERATING TIPS

CAUTION

If an obstruction or foreign object is hit while operating, stop unit by releasing the control bar, unplug extension cord, remove obstruction, and check unit for damage.

1. Keep the area to be cleared free of stones, toys, or other foreign objects which may be picked up and thrown by the rotor blades. Such items could be covered by snowfall and, therefore, unnoticed until struck by the rotor blades. Always be sure to keep children and pets away from area of operation.

2. **ADJUSTING DISCHARGE CHUTE** - Rotate the chute crank clockwise to move discharge chute to the left and counterclockwise to move chute to the right.

The deflector handle on top of the discharge chute controls the height of the snow stream (Fig. 5).

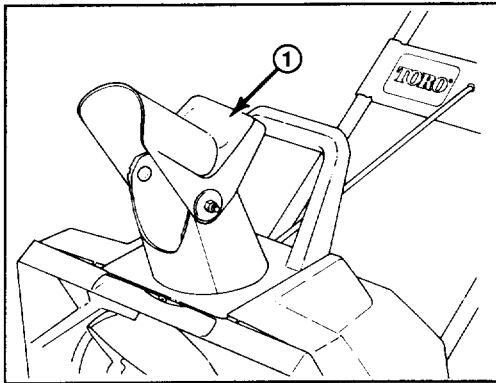

Figure 5

1. Chute deflector handle

WARNING

Do not force the chute deflector over the stops because snow and anything that may be picked up by snowthrower will fly into the operator's zone. Do not over-tighten deflector mounting nuts so excessive force is required to adjust deflector.

3. Begin snow removal near the electrical outlet and work outward. Blow back and forth.

When turning at the end of a swath, step over the cord and turn the snowthrower.

4. Always overlap each swath and discharge snow downwind when possible.

5. Shave down large banks of snow by placing the snowthrower on the bank. Lift the snowthrower by the primary and secondary handles only (Fig. 6).

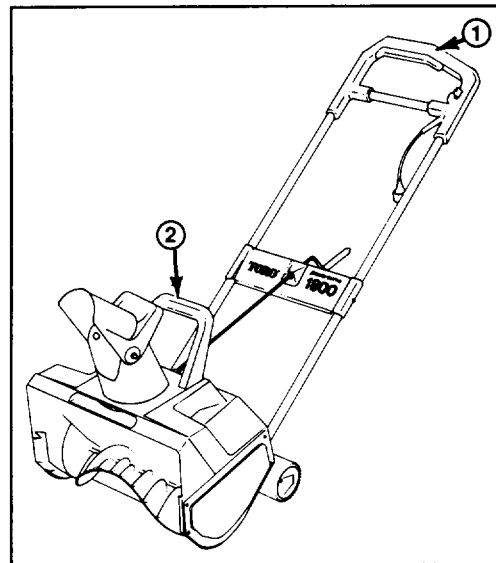

Figure 6

1. Primary handle 2. Secondary handle

OPERATING INSTRUCTIONS

6. When clearing steps or deep drifts, hold the unit by the primary and secondary handles (Fig. 6) and use a swinging or sweeping motion.



WARNING

When using the secondary handle, always turn the discharge chute in the opposite direction from where you are standing.

7. Keep extension cord clear of obstructions, sharp objects, and all moving parts. Do not pull sharply on cord or abuse it in any manner. Frequently inspect cord for damage which could result in electric shock. If cord becomes damaged in any way, replace it.

8. In some snow and cold weather conditions, some controls and moving parts may freeze solid. Therefore,

when any control becomes hard to operate, stop the motor by releasing the control bar, and check all parts for freeze up. **DO NOT USE EXCESSIVE FORCE WHEN TRYING TO OPERATE THE CONTROLS IF FROZEN.** Free all controls and moving parts before operating.

9. **AFTER CLEARING SNOW**—Let motor run for a few minutes so ice doesn't freeze moving parts solid. After motor is shut off, wipe ice and snow off entire unit. Rotate chute crank several times to clear mechanism of snow.

10. Remove the key and disconnect the extension cord when through using the snowthrower. Insert snowthrower plug into cord lock to prevent unauthorized use of machine. To release plug for snowthrower use, insert key into switch and turn clockwise. Keep key in a memorable place so it will not be misplaced.

MAINTENANCE



CAUTION

To prevent accidental operation of the snowthrower while performing maintenance, disconnect extension cord, push extension cord into cord lock, and remove key from handle.

LUBRICATING SNOWTHROWER

The snowthrower does not have to be lubricated as all bearings are lubricated for the life of the product.

REPLACING SCRAPER (Fig. 7)

A replaceable scraper is located at the bottom of the rotor housing.

1. Insert a wide blade screwdriver in the center back of the scraper, and pry it off by twisting the screwdriver.

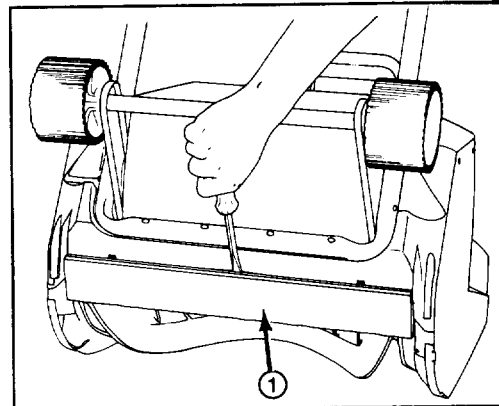

Figure 7

1. Scraper

2. Install the new scraper by sliding it over the front lip and snapping it in place.

MAINTENANCE

Note: Determine left and right sides of snowthrower by standing in the normal operating position.

REPLACING ROTOR

1. Remove (5) screws securing right side cover and skid to snowthrower frame (Fig. 8).

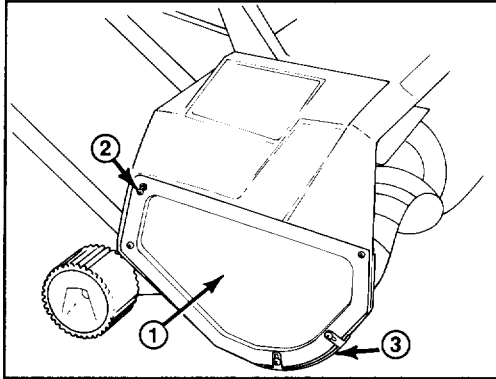

Figure 8

- 1. Right side cover
- 2. Screw
- 3. Skid

2. Using a 3/8" Allen wrench, turn the rotor shaft clockwise (left hand thread) while holding the rotor (Fig. 9). The Allen wrench may need to be tapped with a hammer to loosen the rotor shaft. Wedge a stick or hammer handle in rotor to prevent rotation.

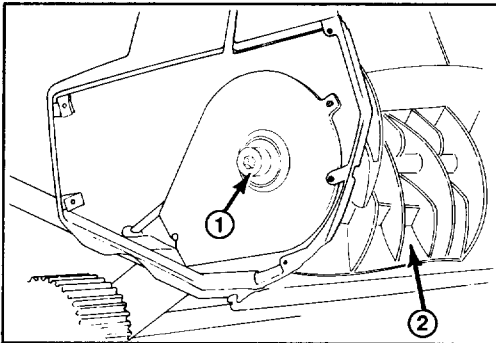

Figure 9

- 1. Rotor shaft
- 2. Rotor

Note: If unable to remove rotor shaft by holding rotor, remove left side cover and skid (Fig. 10) and hold hex nut with a 7/8" wrench while unscrewing rotor shaft (Fig. 11).

3. Hold rotor and pull out rotor shaft.

4. Remove rotor. Retain washer on right side of rotor for reassembly. Replace washer if worn.

5. If necessary, insert a new washer into right side of new rotor.

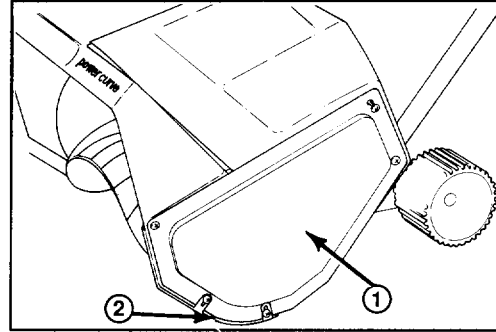

Figure 10

- 1. Left side cover
- 2. Skid

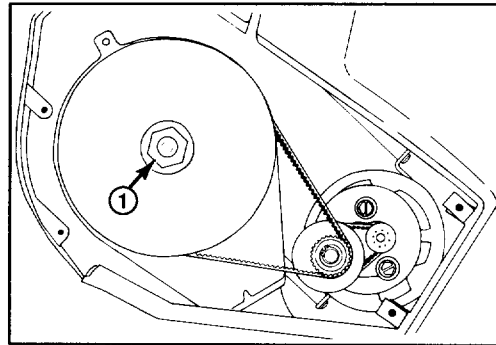

Figure 11

- 1. Hex nut

6. Align the left side of new rotor with coupler. The 3 bosses on the rotor end must align with the slots on the coupler (Fig. 12). Coupler must be aligned with tabs to inside. Slide right side of rotor into mounting position.

MAINTENANCE

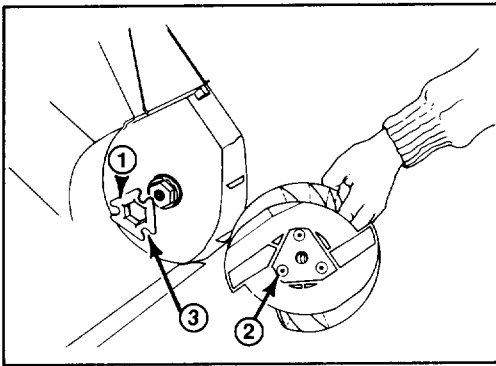

Figure 12

- 1. Coupler
- 2. Boss
- 3. Slot

7. Reinsert rotor shaft through rotor. Make sure that the shaft fits into the bearing on the right side. Torque to a minimum of 10 ft-lbs.

8. Reinstall cover and skid.

REPLACING BELTS

LARGE BELT REPLACEMENT

1. Remove the (5) screws securing the left side plate to the snowthrower frame. Remove side plate and skid.

2. Remove large belt by slowly walking (sliding) it off small pulley (Fig. 13).

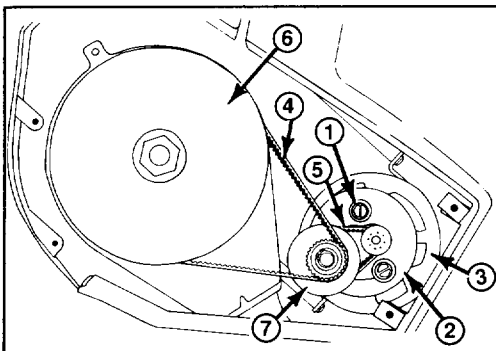

Figure 13

- 1. Socket head screw
- 2. Motor mounting plate
- 3. Motor
- 4. Large belt
- 5. Small belt
- 6. Large pulley
- 7. Small pulley

Note: If unable to remove belt, proceed to next step, otherwise proceed to step 5.

3. Insert a Phillips screwdriver through holes in rear of shroud (Fig. 14) and loosen the (2) screws holding the motor mounting brackets (Fig. 15). Use caution not to damage wires behind shroud.

4. Belt tension will decrease allowing the motor and pulley assembly to rotate clockwise, simplifying belt removal. Slip belt off large pulley (Fig. 13).

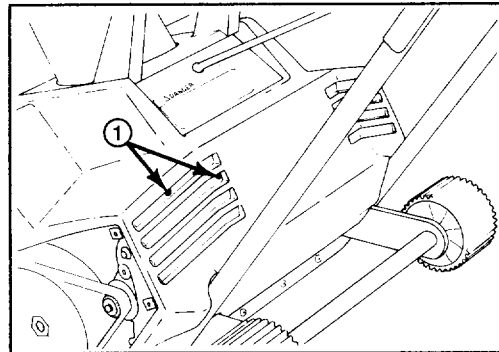

Figure 14

- 1. Holes in rear of shroud

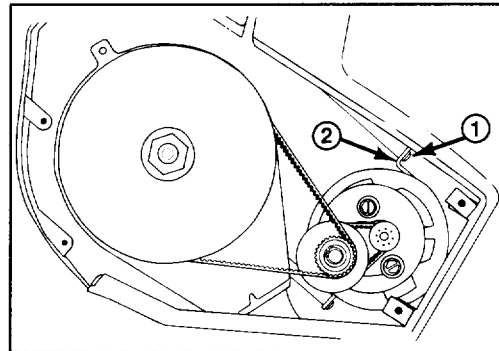

Figure 15

- 1. Screw
- 2. Motor mounting bracket

5. Slip new belt over small pulley and walk (slide) it around large pulley.

MAINTENANCE

6. If motor was rotated to loosen the belt, you first must rotate motor back into place. Wedging a stick or screwdriver between the housing and the small pulley, apply a force of approximately 32 lbs. in a counterclockwise direction, to rotate motor and pulley back into position as shown in fig. 16. Retighten mounting bracket screws through back of shroud.

7. To check belt tension, firmly press in on belt, midway between pulleys. Belt should deflect approximately 3/32".

Note: Make sure motor assembly is pushed inward to keep pulleys aligned.

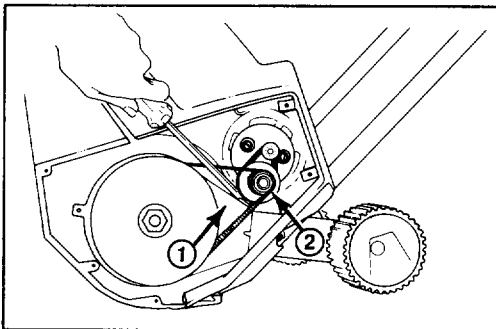

Figure 16

1. Housing 2. Small pulley

8. Install the left side cover and skid with (5) screws.

SMALL BELT REPLACEMENT

1. Remove the (5) screws securing the left side plate to the snowthrower frame. Remove side plate and skid.

2. Remove large belt by slowly walking (sliding) it off small pulley (Fig. 13).

Note: If unable to remove belt, proceed to next step, otherwise proceed to step 5.

3. Insert a Phillips screwdriver through holes in rear of shroud (Fig. 14) and loosen the (2) screws holding the motor mounting brackets (Fig. 15). Use caution not to damage wires behind shroud.

4. Belt tension will decrease allowing motor and pulley assembly to rotate clockwise, simplifying belt removal. Slip belt off large pulley (Fig. 13).

5. Loosen (do not remove) the (2) 5/16" socket head screws on the motor mounting plate (Fig. 13). This allows the small pulley to move simplifying small belt replacement.

6. Remove the "E" Ring and (2) washers securing small pulley to mounting shaft (Fig. 17).

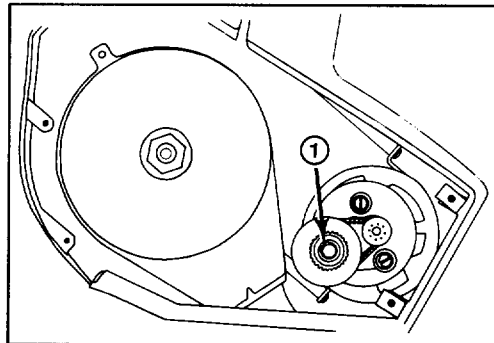

Figure 17

1. E Ring, washers

7. Slide the new belt onto the small pulley and replace washers and E ring.

Note: If motor was rotated to loosen the belt, you must first retighten the (2) mounting bracket screws through back of shroud (Fig. 14 & 15).

8. Rotate the mounting plate clockwise until the belt is tightened to 32 lbs, then tighten the (2) 5/16" socket head screws securing mounting plate.

9. To Check belt tension, firmly, press in on belt, midway between pulleys. Belt should deflect approximately 1/32".

10. Slip large belt over small pulley and walk (slide) it around large pulley.

Note: If unable to install large belt, loosen (2) mounting bracket screws through back of shroud, until pulley moves enough to ease belt installation; refer Large Belt Replacement, page 8.

MAINTENANCE

Note: Make sure motor assembly is pushed inward to keep pulleys aligned.

11. Install the left side cover and skid with (5) screws.

STORING SNOWTHROWER

1. Examine the snowthrower thoroughly for worn, loose, or damaged parts. If parts repair or replacement is necessary, contact your local Authorized TORO Service Dealer for assistance.

2. Examine extension cord and snowthrower cord set thoroughly for signs of wear or damage. Replace, if worn or damaged. Contact your local Authorized TORO Service Dealer or TORO Service Center for genuine TORO replacement parts.

3. Disconnect the extension cord from the snowthrower. Store the extension cord with the snowthrower to prevent misplacement.

4. Store the snowthrower in a clean, dry place, and cover it to provide protection.

TORO SERVICE SUPPORT

If help—concerning safety, set-up, operation, maintenance, or troubleshooting—is ever needed, contact the local Authorized TORO Service Dealer, Distributor, or TORO Service Center. Refer to the “Yellow Pages” for assistance. In addition to skilled service technicians, the dealer and distributor have factory approved accessories and replacement parts. Keep your TORO all TORO. Buy genuine TORO replacement parts and accessories.

PRODUCT IDENTIFICATION

A model and a serial number decal is located on the lower metal tube by the wheels. Always refer to specific numbers on the decal in correspondence or when replacement parts are needed.

The Toro Promise

1800 Power Curve™ Snowthrower A Full One Year Warranty

The Toro Company warrants your TORO product against defects in material or workmanship. During the warranty period, Toro will, at its option, replace a defective product with a new or rebuilt unit, or will repair or replace any defective parts. The following time periods from the date of purchase apply:

Residential Product 1 Year
Residential Products Used Commercially 45 Days

The cost of replacement or repair is included, but the customer pays the transportation costs.

Should you feel your TORO Product is defective and wish to rely on The Toro Promise, you may return it to:

1. The original place of purchase
OR
2. A TORO Electrical Service Dealer
OR
3. The Toro Service Center
5300 Shoreline Blvd.
Mound, MN 55364
(Postage Prepaid)

Upon return of your unit to one of the above, it will be inspected and you will be advised whether the product is defective. If defective, arrangements will be made for repair or replacement without extra charge to you.

If for any reason you are dissatisfied with the analysis of the defect or the service performed, you may contact us.

Write: TORO Customer Service Center
Home Improvement Division
8111 Lyndale Avenue South
Minneapolis, MN 55420

THERE IS NO OTHER EXPRESS WARRANTY.

THE TORO COMPANY IS NOT
LIABLE FOR INDIRECT OR CONSEQUENTIAL DAMAGES IN CONNECTION

WITH THE USE OF THE PRODUCT.

Some states do not allow the exclusion or limitation of incidental or consequential damages, so the above limitation or exclusion may not apply to you.

This warranty applies only to parts or components which are defective and does not cover repairs necessary due to normal wear, misuse, accidents, or lack of proper maintenance. Regular, routine maintenance of the unit to keep it in proper operating condition is the responsibility of the owner.

All warranty repairs reimbursable under The Toro Promise must be performed by a Toro Electrical Service Dealer using Toro approved replacement parts.

Repairs or attempted repairs by anyone other than a TORO Electrical Service Dealer are not reimbursable under the TORO Promise. In addition, these unauthorized repair attempts may result in additional malfunctions, the correction of which is not covered by warranty.

This warranty gives you specific legal rights, and you may also have other rights which vary from state to state.

COUNTRIES OTHER THAN THE UNITED STATES OR CANADA

Customers who have purchased TORO products exported from the United States or Canada should contact their TORO Distributor (Dealer) to obtain guarantee policies for your country, province, or state. If for any reason you are dissatisfied with your Distributor's service or have difficulty obtaining guarantee information, contact the TORO Importer. If all other remedies fail, you may contact us at The Toro Company.