



Count on it.

Parts Catalog

CM-958H-PED Concrete Mixer

Model No. 68008—Serial No. 313000001 and Up



Ordering Replacement Parts

To order replacement parts, please supply the part number, the quantity, and the description of each part desired.

Understanding Reference Numbers

Each identified part in an illustration has a reference number. The reference number for a part also appears in the parts list, along with other information about the part.

This catalog uses two special reference number formats, one to indicate parts in a service assembly and another to indicate the quantity of a given part in an illustration.

Service Assembly Reference Numbers

Parts in service assemblies have reference numbers in the form a:b. The a represents the reference number of the entire service assembly and the b represents a sequential number unique to each part within the service assembly.

For example, a wheel assembly might be identified by reference number 6, the tire by 6:1, the valve by 6:2, and the wheel by 6:3. When you order the assembly identified by reference number 6, you receive all parts identified by reference numbers 6:1, 6:2, and 6:3. However, you may also order any part individually. Reference numbers of this type appear in illustration and in parts lists.

Reference Numbers Indicating Quantity

In an illustration, if a reference number indicates more than one part, the reference number has the form nX y. The n represents the quantity of the part, the X is the multiplication symbol, and the y represents the reference number.

For example, in an illustration, the reference number 2X 37 means that two of the parts identified by reference number 37 are indicated.

List of Abbreviations

AR: as required

ASM: assembly

BBC: blade brake control

BHTF: button head thread forming

CARR: carriage

CCW: counter clockwise

CW: clockwise

DEG: degrees

DPA: Dual Point Adjustment

ECM: electronic control module

EXT: external

FH: flat head

GA: gauge

HD: heavy-duty

HF: hex flange

HH: hex head

HHF: hex head flange

HHFTF: hex head flange thread forming

HJ: hex jam

HLH: hex lag head

HOC: height-of-cut

HSBH: hex socket button head

HSFH: hex socket flat head

HSH: hex socket head

HWH: hex washer head

HWHTF: hex washer head thread forming

HYD: hydraulic

LH: left hand

LP: Liquefied Petroleum Gas

LPG: Liquefied Petroleum Gas

NI: nylon insert

NPTF: national pipe thread fine

PFH: phillips flat head

PPH: phillips pan head

PPHTF: phillips pan head thread forming

PRH: phillips round head

PTH: phillips truss head

PTO: power-take-off

RH: right hand

ROPS: roll-over protection system

RRB: rear roller brush

SFH: slotted fillister head

SHH: slotted hex head

SHWH: slotted hex washer head

SPH: slotted pan head

SQH: square head

SRH: slotted round head

STD: standard

TAP: self tapping

TTH: torx truss head

Contents

Frame and Yoke Assembly	4
Axle Assembly	6
Hub Assembly No. 125-8171	7
Engine and Belt Assembly	8
Drum Assembly	9
Cowl Assembly	10
Attachments and Accessories	11

Frame and Yoke Assembly

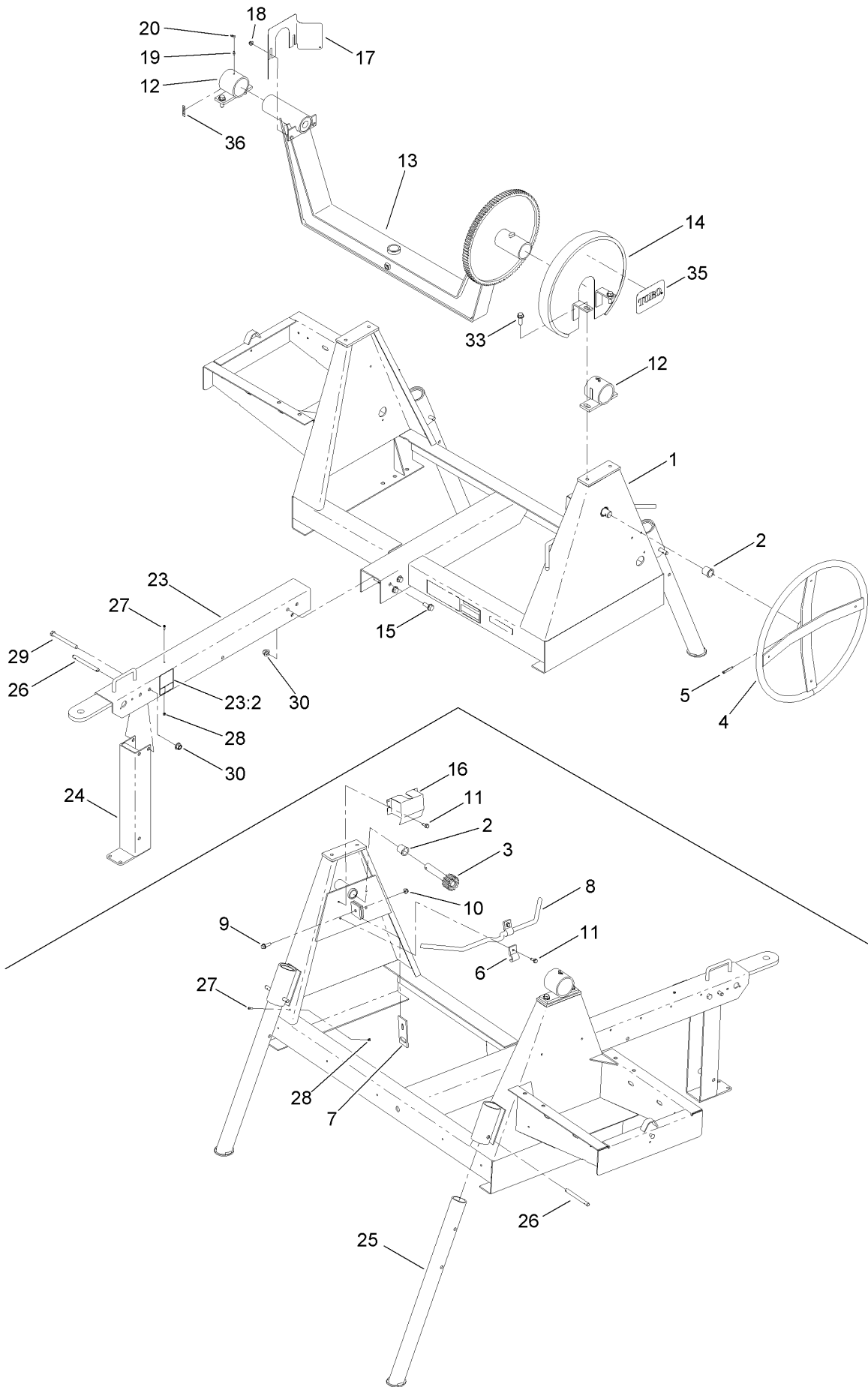

Frame and Yoke Assembly (continued)

<i>Ref.</i>	<i>Part Number</i>	<i>Qty.</i>	<i>Description</i>	<i>Ref.</i>	<i>Part Number</i>	<i>Qty.</i>	<i>Description</i>
1	125-8685-03	1	Frame	17	ST27144-03	1	Guard-Pinion
2	ST32032	2	Bushing-Nylon	18	104-8300	1	Nut-Flange, NI
3	ST22029	1	Shaft-Tilt	19	ST46042	2	Fitting-Grease
4	ST22096-03	1	Handwheel	20	ST47001	2	Cap-Plug
5	32121-27	1	Pin-Roll	23	127-2816	1	Tow Pole ASM
6	ST27559-03	2	Bracket-Handle	23:2	125-8216	1	Decal-Safety Chain, Towing
7	ST27619-03	1	Dog-Brake	24	ST21875-03	1	Post-Foot
8	ST27733-03	1	Handle-Brake	25	ST21874-03	2	Leg-Stabilizer
9	3234-24	1	Screw-HHF	26	ST80039	3	Pin-Clevis, Lanyard
10	104-8301	1	Nut-Flange, NI	27	3290-500	3	Screw-PPH
11	701243	4	Screw-HWHTF	28	3296-2	3	Nut-Lock, NI
12	ST24349-03	2	Trunnion	29	325-19	1	Screw-HH
13	125-6308	1	Yoke ASM	30	99-5107	9	Nut-Lock
14	ST27617-03	1	Guard-Brake, Upper	33	ST80031	4	Screw-HWH
15	3234-38	6	Screw-HHF	35	99-4693	1	Decal
16	ST27618-03	1	Guard-Brake, Lower	36	125-8175	2	Decal-Grease

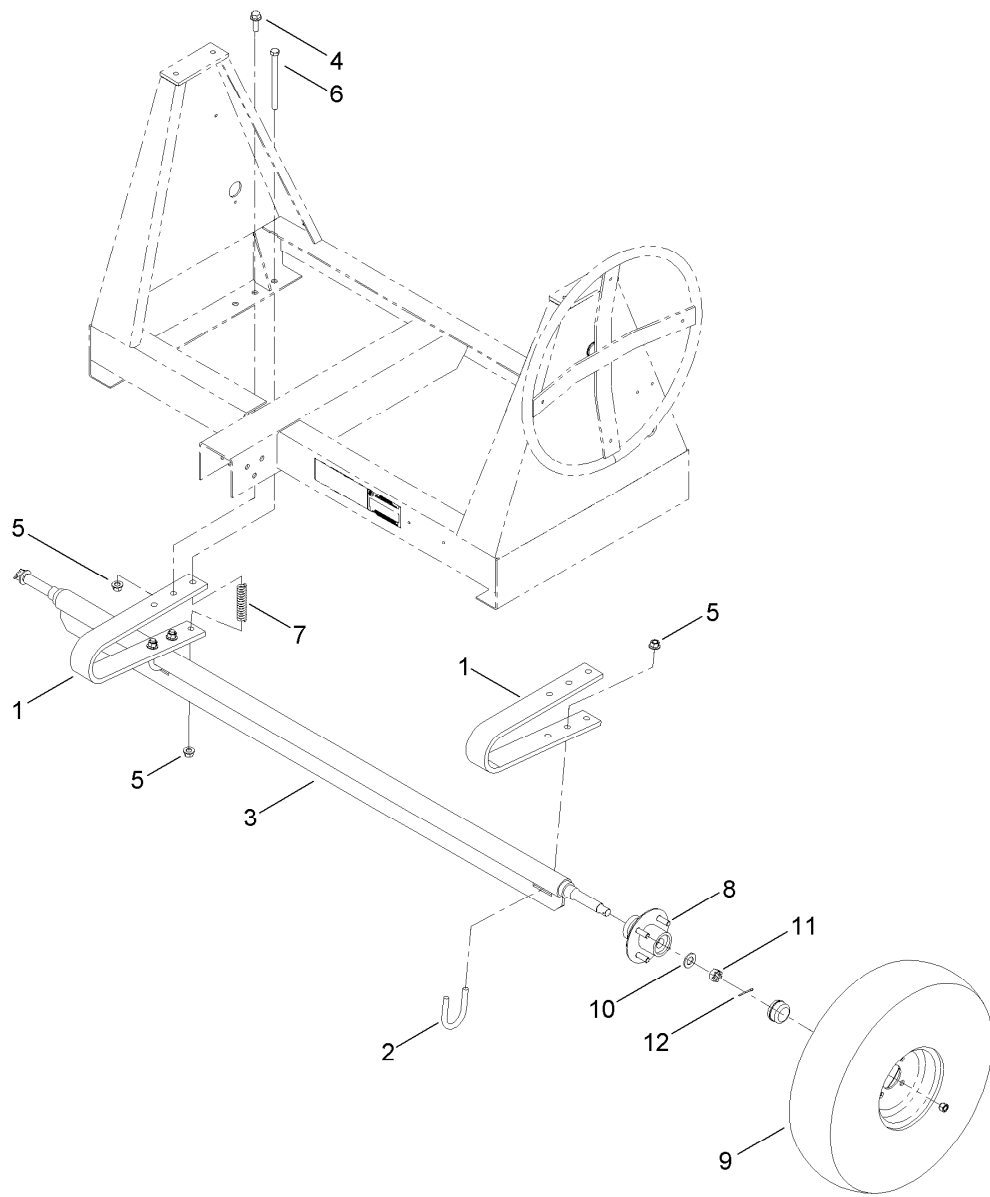

Axle Assembly

<i>Ref.</i>	<i>Part Number</i>	<i>Qty.</i>	<i>Description</i>
1	ST26971	2	Spring-Leaf
2	ST26195	2	Bolt-U
3	ST21873-03	1	Axle-Spring
4	100-6116	4	Screw-HHF
5	99-5107	10	Nut-Lock
6	325-33	2	Screw-HH
7	ST34972	2	Spring-Coil
8	125-8171	2	Hub ASM
9	ST32307	2	Tire And Rim ASM
10	3256-28	2	Washer-Flat
11	ST80054	2	Nut
12	3272-13	2	Pin-Cotter

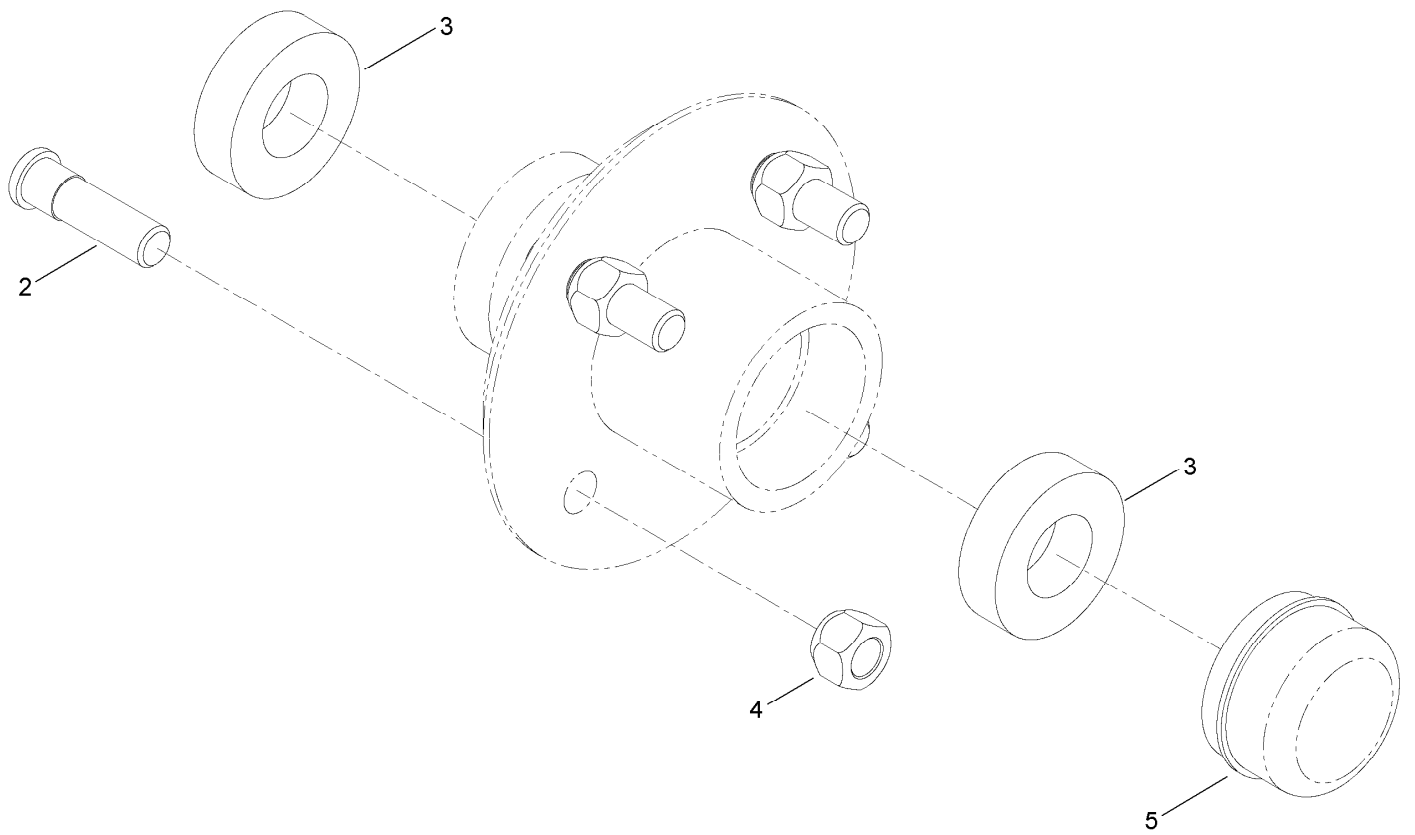

Hub Assembly No. 125-8171

<i>Ref.</i>	<i>Part Number</i>	<i>Qty.</i>	<i>Description</i>
2	ST39190	4	Stud-Wheel
3	ST32233	2	Bearing-Roller
4	ST80045	4	Nut-Lug
5	ST34573	1	Cap-Dust

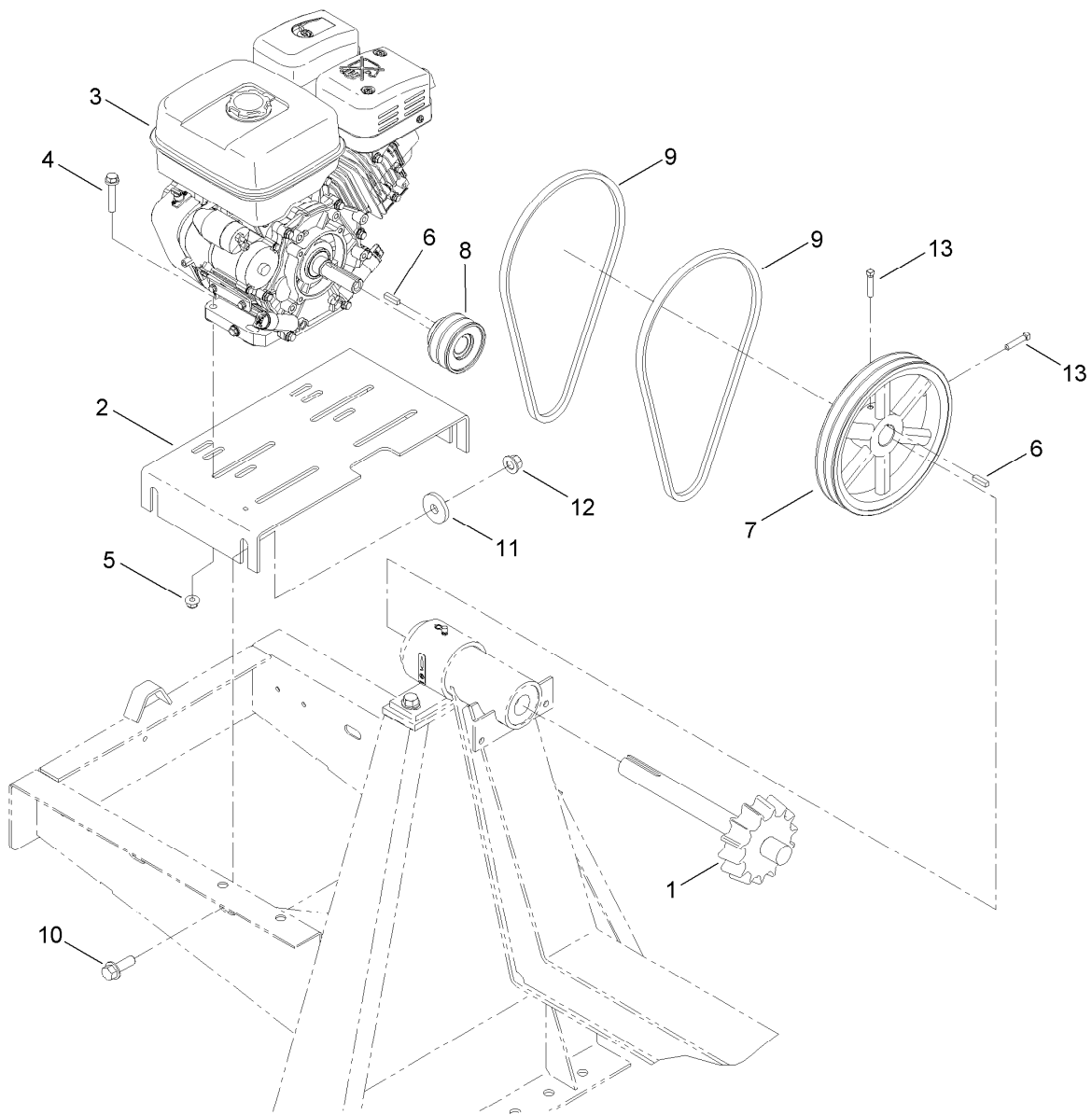

Engine and Belt Assembly

Ref.	Part Number	Qty.	Description
1	ST21487	1	Shaft-Drive
2	ST28045-03	1	Base-Motor
3	125-4812	1	Engine-Honda, Gx240 ●
4	108-3742	4	Screw-HHF
5	104-8301	4	Nut-Flange, NI
6	5-7280	2	Key
7	ST34986-03	1	Sheave
8	ST34984	1	Sheave
9	127-0075	2	Belt-V
10	100-6116	4	Screw-HHF
11	ST26326	4	Washer-Flat
12	99-5107	4	Nut-Lock
13	909546	2	Screw-Set, SQH

● Obtain parts from www.honda-engines.com

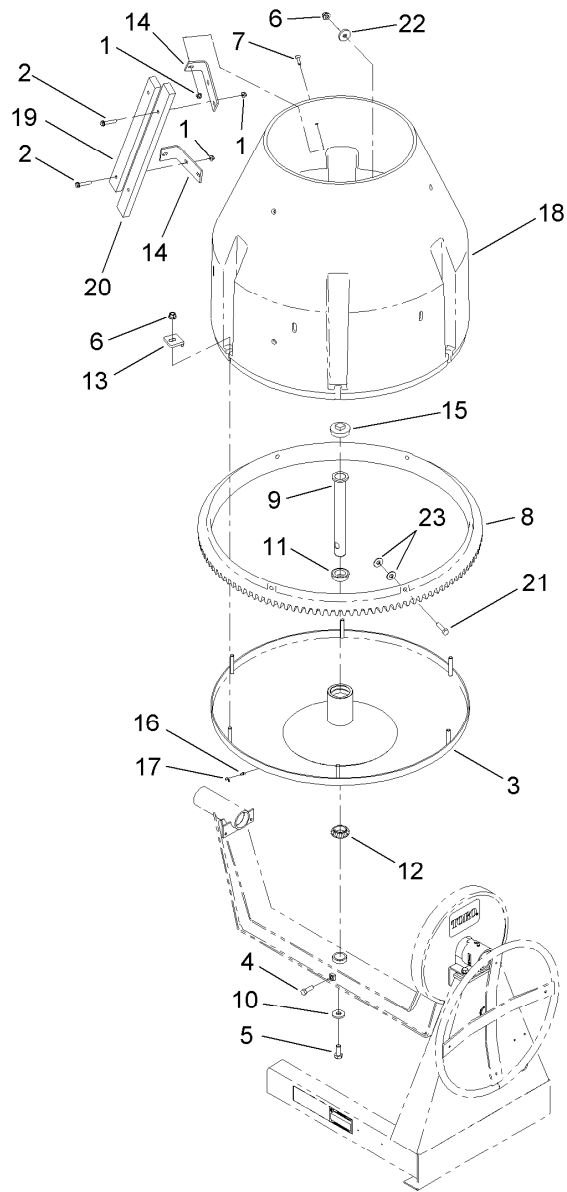

Drum Assembly

<i>Ref.</i>	<i>Part Number</i>	<i>Qty.</i>	<i>Description</i>	<i>Ref.</i>	<i>Part Number</i>	<i>Qty.</i>	<i>Description</i>
1	104-8301	18	Nut-Flange, NI	13	ST42781-01	6	Clamp-Drum
2	108-3742	12	Screw-HHF	14	ST42810-01	6	Bracket-Paddle
3	125-8170-01	1	Dish	15	ST46022	1	Plug
4	325-6	1	Screw-HH	16	ST46057	1	Fitting
5	327-4	1	Screw-HH	17	ST47001	1	Cap-Plug
6	99-5107	6	Nut-Lock	18	125-6202	1	Drum
7	99-8051	6	Screw-HSFH, Countersunk	19	ST47341	3	Paddle
8	ST26317-01	1	Gear-Ring	20	ST47342	3	Paddle
9	ST27267	1	Spindle	21	325-8	6	Screw-HH
10	ST27413	1	Washer-Flat	22	ST26326	6	Washer-Flat
11	ST32086	1	Bearing	23	3256-6	12	Washer-Flat
12	ST32161	1	Bearing-Roller				

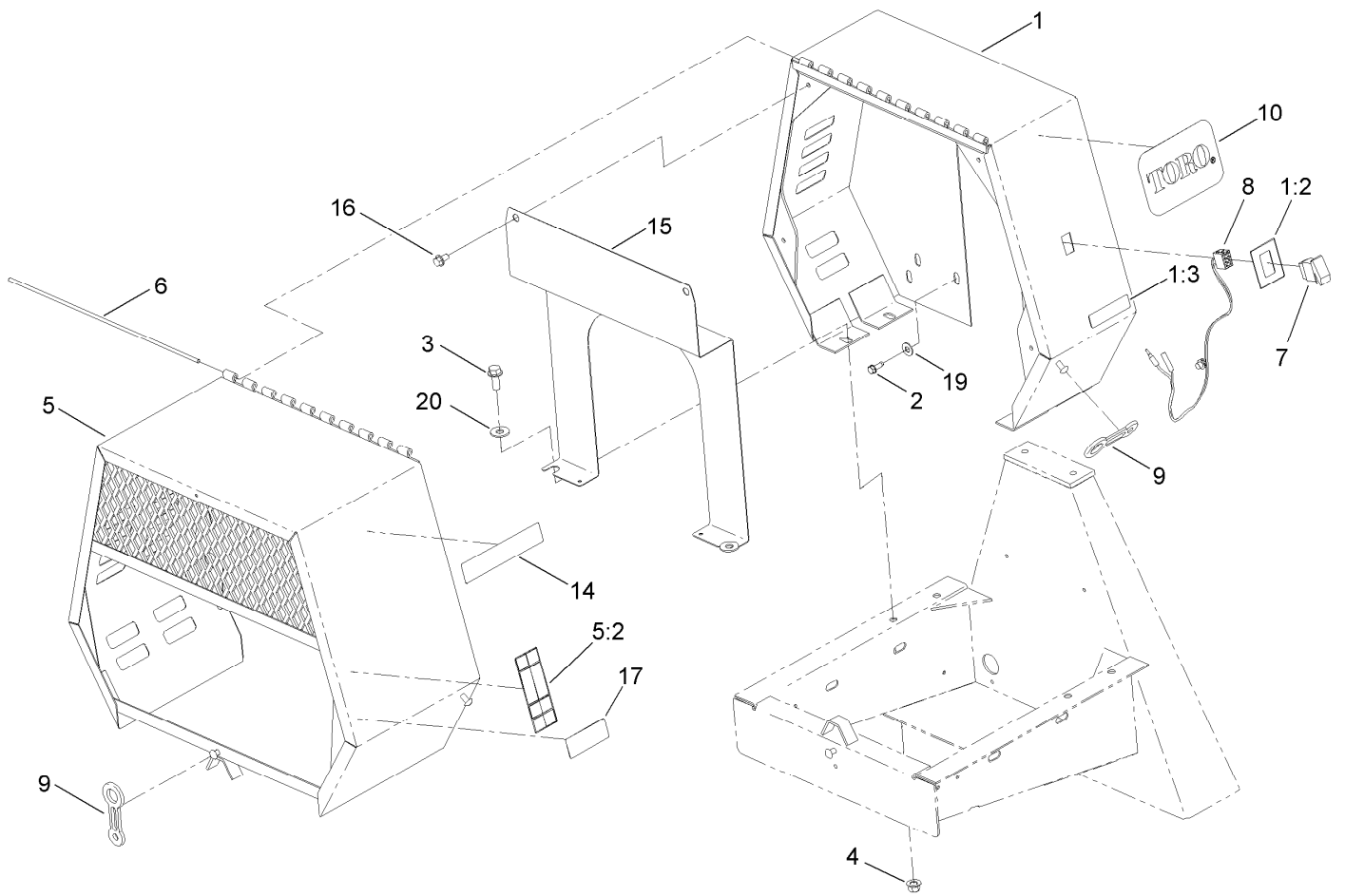

Cowl Assembly

Ref.	Part Number	Qty.	Description	Ref.	Part Number	Qty.	Description
1	127-2811	1	Stationary Cowl ASM	8	125-4877	1	Harness-Wire, Mixer
1:2	125-4940	1	Decal-Engine Stop	9	ST47182	3	Latch-Rubber
1:3	117-2718	1	Decal-Arrester, Spark	10	67-7320	2	Decal
2	701243	2	Screw-HWHTF	14	125-4937	2	Decal
3	3234-38	4	Screw-HHF	15	125-8218-03	1	Plate-Engine
4	99-5107	4	Nut-Lock	16	110-9380	2	Screw-HWH
5	127-1685	1	Movable Cowl ASM	17	125-4942	1	Decal
5:2	125-4939	1	Decal-Warning	19	3256-4	2	Washer-Flat
6	ST44368	1	Pin	20	3256-6	2	Washer-Flat
7	95-8999	1	Switch				

Attachments and Accessories

For 68008 CM-958H-PED Concrete Mixer

Product Name

Model/Part

Trailer Light Kit..... 68063



Count on it.