



MODEL NO. 20667 - 00000001 & UP

OPERATOR'S
MANUAL21" (0.53 M) SP REAR BAGGER
FINGERTIP START

SAFETY INSTRUCTIONS

This mower "meets or exceeds CPSC blade safety requirements for walk behind rotary mowers" and the B71.1-1986 specifications of the American National Standards Institute. However, improper use or maintenance by the operator or owner can result in injury. To reduce the potential for injury, comply with these safety instructions and always pay attention to the safety alert symbol. Failure to comply with these instructions may result in personal injury.

BEFORE OPERATING

1. Read this manual carefully before operating the mower. Become familiar with the controls and proper use of the mower. Never allow children to operate the mower or adults to operate it without proper instructions.
2. Keep everyone, especially children and pets, away from area of operation. Thoroughly inspect area where mower will be used and remove sticks, stones, wire, and debris.
3. Wear long pants and substantial shoes. Do not operate mower while wearing open sandals or when barefoot.
4. Always wear safety glasses or eye shields during operation to protect eyes from foreign objects that may be thrown from the machine.
5. Check fuel level before starting engine. Do not fill fuel tank indoors, when the engine is running, or until engine cools for several minutes after running. Wipe up spilled gasoline before starting engine.
6. Keep all guards, shields, and safety devices in place. Repair or replace defective or damaged parts.
7. Traction drive and blade are designed to stop when control bar is released. Assure control and brake function properly before each use of mower.

WHILE OPERATING

8. Do not run engine indoors.
9. Always maintain secure footing. Keep a firm grip on the handle and walk; never run. Never operate mower in wet grass. Mow only in daylight or in good artificial light.

10. Mow across the face of slopes; never up and down. Use extreme caution when changing direction on slopes. Do not mow excessively steep slopes.

11. Keep face, hands, and feet away from the mower housing and cutter blade when the engine is running. Stay behind the handle until the engine stops and keep clear of discharge opening at all times.

12. When mulching, assure discharge door is closed. When bagging grass, stop engine before the bag is removed and emptied.

13. Shut engine off and wait for all moving parts to stop before unclogging chute.

14. Since the blade rotates for a few seconds after the blade control is released, stay behind the handle until all moving parts stop.

15. After striking a foreign object or if mower vibrates abnormally, stop engine and remove wire from spark plug. Check mower for damage and make all repairs before using mower again.

16. Stop the engine before adjusting the height-of-cut.

17. Stop the blade when crossing a gravel driveway, road, or sidewalk.

18. Stop engine before leaving the operator's position—behind the handle. Disconnect wire from spark plug if mower will be unattended.

19. Do not touch engine while it is running or shortly after it is stopped because engine will be hot enough to cause a burn.

SAFETY INSTRUCTIONS

MAINTENANCE

20. Perform only those maintenance instructions described in this manual. If major repairs are ever needed or if assistance is desired, contact your local Authorized TORO Service Dealer.

21. Before mower is cleaned, inspected, serviced, or adjusted, stop engine and disconnect high tension wire from spark plug. Keep wire away from plug to prevent accidental starting.

22. To assure the mower is in safe operating condition, frequently check and keep all nuts, bolts, and screws tight. Assure blade nuts are tightened to 20–35 ft-lb.

23. To reduce fire hazard, keep engine free of excessive grease, grass, leaves, and accumulations of dirt.

24. Check grass catcher bag frequently for wear or deterioration. Replace with a new bag for your protection.

25. Allow engine to cool before storing mower in any enclosure. Do not store mower near any open flame or where gasoline fumes may be ignited by a spark.

26. Do not overspeed the engine by changing governor settings.

27. At the time of manufacture, the mower conformed to the safety standards in effect for rotary mowers. To assure optimum performance and continued safety certification of the mower, use genuine TORO replacement parts and accessories. Replacement parts and accessories made by other manufacturers may result in non-conformance with the safety standards, and that could be dangerous.

SAFETY DECALS

Safety decals and instructions are easily visible to the operator and are located near any area of potential danger. Replace any decal that is damaged.



**PLACE FOOT HERE
WHEN STARTING**

On mower deck
(Part No. 46-7370)

Keep hands and feet
away from rotating blade



On top of
discharge tunnel

On mower housing
(Part No. 43-8480)

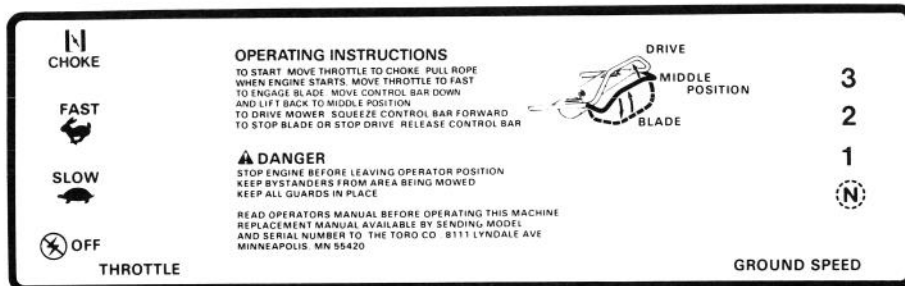

On control panel

TABLE OF CONTENTS

	Page		Page
Set-Up Instructions	3	Lubrication	11
Before Operating	3-4	Adjusting Blade Brake	11
Operating Instructions	5-7	Adjusting Ground Speed Control For Neutral	12
Maintenance	8-15	Cleaning Blade Brake Clutch Shield ...	12
Servicing Air Cleaner	8	Cleaning Mower Housing	12-13
Replacing Spark Plug	8	Preparing Mower For Storage	13
Draining Gasoline	8-9	Optional Equipment	14
Changing Crankcase Oil	9	Toro Service Support	14
Adjusting Throttle	9	Product Identification	14
Adjusting Wheel Drive	10	Maintenance Record	15
Inspecting/Removing/Sharpening Blade	10-11	The Toro Promise	

SET-UP INSTRUCTIONS

INSTALL HANDLE AND BAG

1. Align handles and tighten handle knobs (Fig. 1). Bend handle latches slightly outward (Fig. 1).

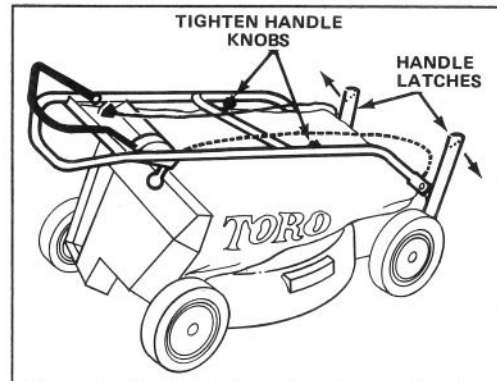

Figure 1

2. Pivot handle backward until handle stud snaps into center hole of handle latch (Fig. 2). Assure control cables are to the rear and inside of handles.

3. Handle height may be adjusted to desired position by moving handle studs to one of the other holes in handle latch.

4. Install grass bag; refer to Using Grass Bag, page 6, steps 1-5.

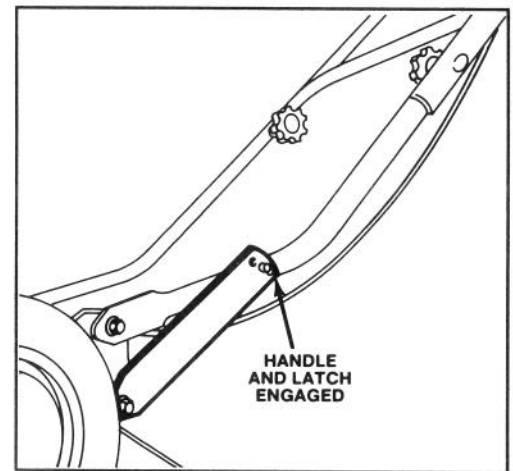

Figure 2

BEFORE OPERATING

FILL CRANKCASE WITH OIL

Initially, crankcase must be filled with 18 ounces (0.532 L) of SAE 10W30 oil. Use any high quality detergent oil having the American Petroleum Institute (API) "service classification" — SC, SD, SE or SF.

Before each use, assure oil level is between FULL and ADD marks on dipstick (Fig. 3). Add oil if level is low.

1. Position mower on level surface and clean around oil dipstick.
2. Remove dipstick by rotating cap counter-clockwise 1/4 turn.

BEFORE OPERATING

3. Wipe dipstick and insert it into filler neck. Rotate cap clockwise 1/4 turn. Then remove dipstick and check level of oil (Fig. 3). If level is low, add only enough oil to raise level to FULL mark on dipstick. **DO NOT FILL ABOVE FULL MARK BECAUSE ENGINE COULD BE DAMAGED WHEN STARTED. POUR SLOWLY.**

4. Insert dipstick into filler neck and rotate cap clockwise 1/4 turn to lock.

Note: Check oil level each time mower is used or after every 5 operating hours. Initially, change oil after the first 2 hours of operation; thereafter, change oil after every 25 hours of operation. More frequent oil changes are required in dusty or dirty conditions.

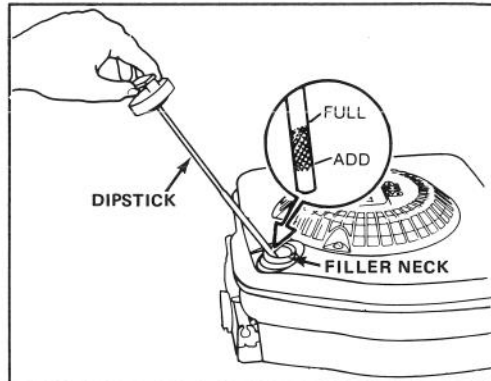

Figure 3



WARNING

DANGER: Gasoline is extremely flammable and explosive under certain conditions. Do not smoke when handling fuel and keep fuel far away from open flames and sparks. Never buy more than a 30 day supply of gasoline. Store it in an approved container. Keep gasoline out of reach of children.

Refuel outdoors and only when engine is cold. Do not fill tank full. Fill tank to within 1/4" to 1/2" (6 to 13 mm) from bottom of filler neck, not into filler neck. This space is for expansion of fuel. Use funnel or spout to prevent spilling. Wipe up any spilled gas.

FILL FUEL TANK WITH GASOLINE

Note: The Toro Company strongly recommends the use of fresh, clean, **UNLEADED** regular grade gasoline in Toro gasoline powered products. Unleaded gasoline burns cleaner, extends engine life, and promotes good starting by reducing the build-up of combustion chamber deposits. Leaded gasoline can be used if unleaded is not available.

1. Clean around fuel tank cap and remove cap from tank (Fig. 3). Using unleaded gasoline, fill fuel tank to within 1/2 inch (13 mm) from top of tank.
2. Install fuel tank cap and wipe up any spilled gasoline.
3. Move fuel shut-off valve to the ON position (Fig. 4).

IMPORTANT: Do not mix oil with the gasoline. Never use methanol, gasoline containing methanol, gasohol containing more than 10% ethanol, premium gasoline, or white gas because engine fuel system damage could result.

Do not use fuel additives other than those manufactured for fuel stabilization during storage (such as Toro's Preservit or a similar product). Additives should not be used to try to enhance power or performance of machine. Only use an isopropyl alcohol base fuel additive.

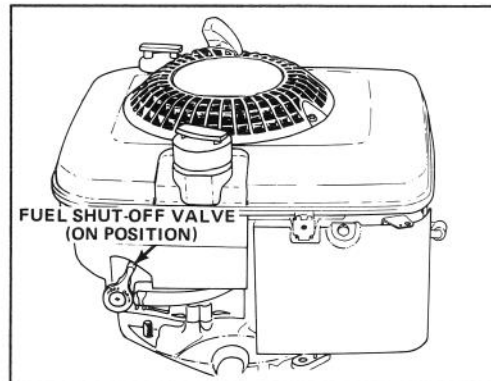
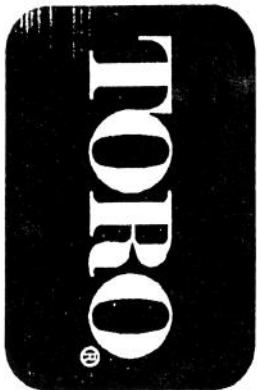

Figure 4



MODEL 20667-0000001 & UP

OPERATOR'S MANUAL
ADDENDUM

The following procedure replaces the Changing Crankcase Oil procedure in your Operator's Manual. Please place this addendum with your Operator's Manual for future reference.

CHANGING CRANKCASE OIL (Fig. 1)

Many mowers equipped with blade brake clutch (BBC) systems require that the engine oil be drained through the oil fill tube. The oil should be hot to provide for best flow of oil and contaminants from the engine. Also, the fuel tank should be no more than half full.

Note: Determine left and right sides of mower by standing in normal operator's position.

1. Place mower on a flat surface.
2. Place drain container next to right side of mower. For best results, use a flat, shallow pan.
3. Remove dipstick from oil fill tube.
4. Tip mower on its right side, and rest it on handle and wheels.
5. Allow oil to drain from oil fill tube.
6. Tip mower back on all four wheels.

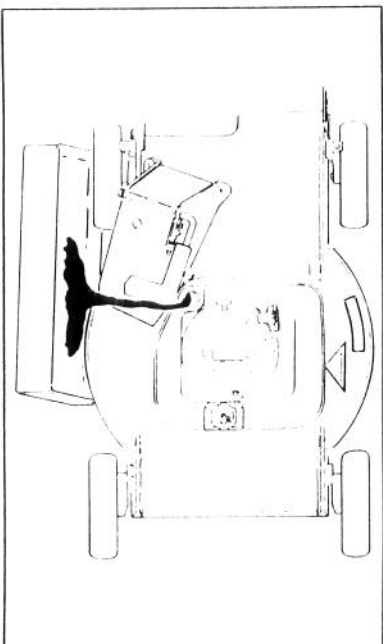

Figure 1

7. Add approximately 8 ounces of 10W30 oil. Continue to add and check the oil until the level reaches the full mark on the dipstick.
8. Reinstall the dipstick.

OPERATING INSTRUCTIONS

OPERATING TIPS

1. **CHECK OIL LEVEL**— Maintain oil level between ADD and FULL marks as shown on dipstick (Fig. 4).
2. **BEFORE EACH MOWING**— Assure blade brake, self-propelled drive, and control bar function properly. When control bar is released, blade and self-propelled drive are designed to stop.
3. **CUTTING AND BAGGING**— Best results are achieved when engine is running at maximum speed and only about 1/3 of the grass blade is cut. If long grass must be cut, use highest height-of-cut setting for first mowing. Then recut the grass at a more normal setting. If too long of grass is cut, mower may plug and cause engine to stall.
4. **MULCHING**— In summer when grass grows slower and is drier, mulch by removing the grass bag and closing the discharge door (Fig. 5).
5. **SHARP BLADE**— Begin each cutting season with a sharp blade. Periodically file down nicks.

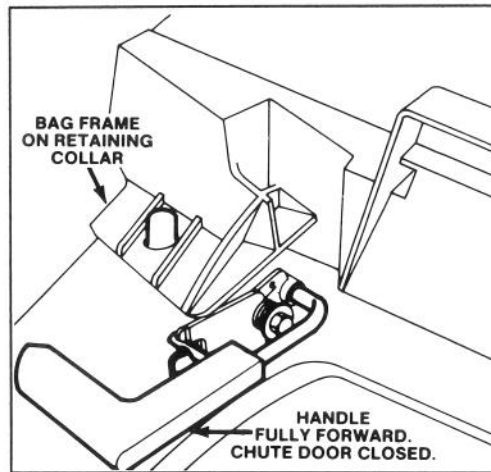

Figure 5

STARTING, STOPPING, AND SELF-PROPELLING

1. **CONTROLS**— Throttle, ground speed control, and blade/self-propelled control bar are on upper handle (Fig. 6). Recoil starter is on top of engine.

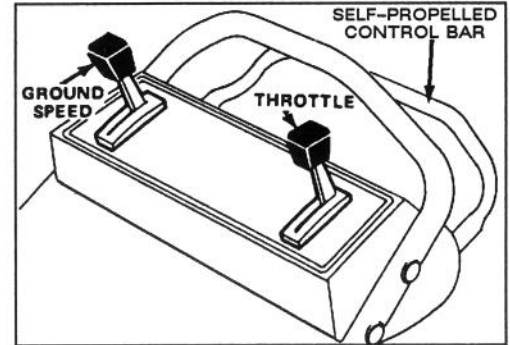

Figure 6

2. Push spark plug wire onto spark plug (Fig. 7).
3. Move ground speed control to "N" (Fig. 6).
4. Move throttle to CHOKE. Pull engine mounted fingertip starter out until positive engagement results; then pull vigorously to start the engine. Regulate throttle as desired when engine starts. When temperature is near 40°F, a few extra pulls may be required because the engine needs priming.

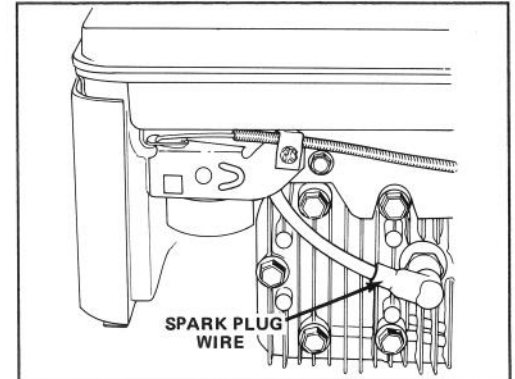

Figure 7

5. **GROUND SPEED**— Move ground speed control to desired setting. Number "1" is slow, "2" is medium, and "3" is a fast walking pace. Move ground speed control to "N" when using the mower for trimming and whenever leaving mower.
6. **BLADE AND TRACTION OPERATION** (Fig. 8)— Move control bar down to "A" and raise to engage blade "B". Move ground speed control to desired setting and squeeze control bar against handle "C" to drive. Ground speed varies, depending on space between control bar and handle.

OPERATING INSTRUCTIONS

To disengage traction drive, but keep blade engaged, gradually release control bar to mid position. To self-propel with blade disengaged, simply squeeze control bar against handle, eliminating downward movement necessary for blade engagement.

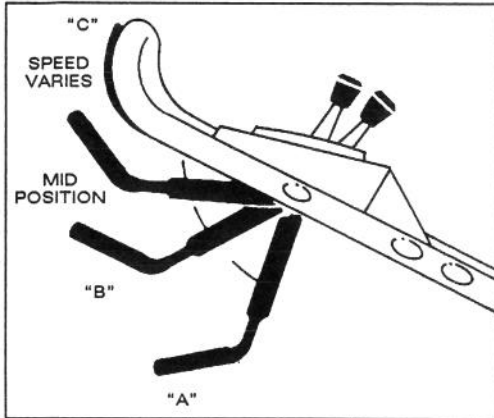

Figure 8

7. STOPPING (Fig. 6) — Release control bar to stop blade and traction drive. Move ground speed control to "N". To stop engine, move throttle to OFF. Pull wire off spark plug if mower will be unattended or not used.

USING GRASS BAG

1. Stop engine and wait for all parts to stop.
2. Assure chute door handle is fully forward and pin is engaged in catch.
3. INSTALLING BAG — Slide hole in bag frame onto retaining post on housing (Fig. 9) and set rear of bag frame onto lower handle.

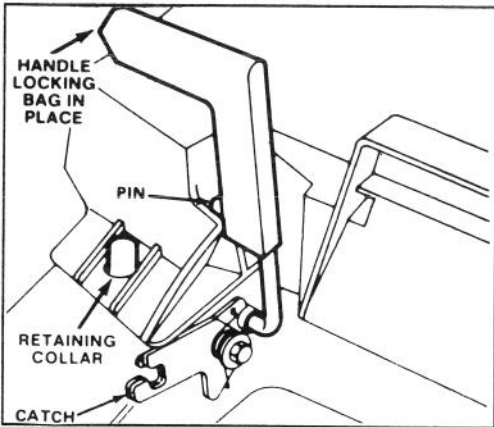

Figure 9

4. Pull chute door handle forward until pin clears catch and move handle rearward until pin locks in bag notch (Fig. 9). Chute door in mower housing is now open. It may be necessary to push down on top right of bag door to release handle locking pin from catch.

CAUTION

Except when side discharge attachment is used, never open chute door on mower when engine is running because grass clippings and other debris discharges with enough force to cause injury.

The grass bag material will catch and contain the majority of foreign objects such as small stones and other similar debris. The bag material, however, is subject to normal wear and deterioration. So check the bag frequently, and if it is defective, install a new genuine TORO replacement bag that has this or similar warning.

5. EMPTYING BAG — Release control bar and wait for blade to stop. For protection, always keep hands and feet away from mower housing when engine is running. Move chute door handle forward to engage the locking pin with catch (Fig. 5). Grasp handle at front and rear of bag and lift bag off mower. Gradually tip bag forward to empty clippings.

6. To reinstall bag, repeat steps 3-4.

CAUTION

If chute door cannot be closed because grass clippings clog discharge area, stop engine and gently move chute door handle back and forth until door can be closed completely. Do not force chute door closed because door or handle may be damaged. If door still cannot be closed, remove obstruction.

OPERATING INSTRUCTIONS

ADJUSTING HEIGHT-OF-CUT

Five letters cast into the housing represent each graduated increment (Fig. 10).

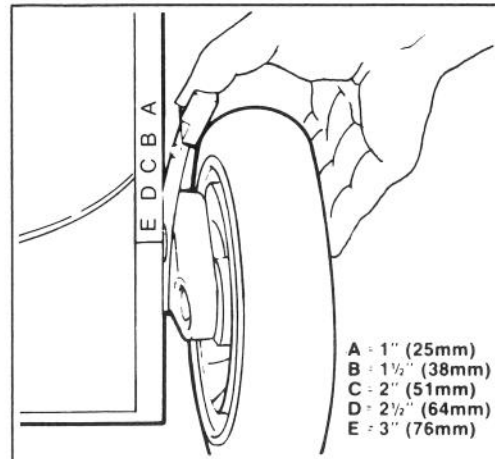

Figure 10

1. Stop the engine.
2. For easier adjustment, lift housing up so wheel is off ground. Squeeze adjusting lever toward wheel and move to desired setting (Fig. 10). Assure pin on adjusting lever engages notch in housing. Adjust all wheels to the same setting.

Note: Front wheels can be adjusted to 1/2 inch. Move adjusting lever past "A" and release pin into rear most notch in housing.

CHECK CONTROL BAR OPERATION

Control bar should be checked periodically, at the beginning of each mowing season as a minimum, to assure the Blade Brake Clutch (BBC) system is operating properly.

1. Start engine; refer to Starting, page 5.
2. Push the control bar down to the lowest position (Fig. 11). This "cocks" the mechanism prior to engaging the blade.
3. Lift the control bar to the normal "blade engaged" position, about 1" below the handle (Fig. 11). The "fan" noise and bag inflation indicate that the mower blade is engaged and rotating.
4. Release the control bar. A "bang" should be heard, and the blade should stop within 3 seconds. If the blade does not stop within 3 seconds when the control bar is released, stop using mower until it has been serviced by an Authorized TORO Service Dealer.

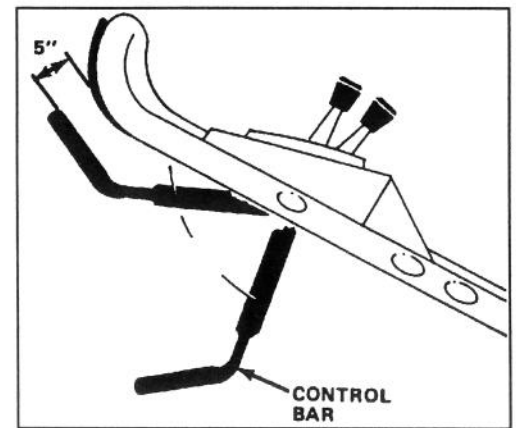

Figure 11

If your unit stops within the required 3 seconds, the BBC system is operating properly. However, to detect the BBC system deterioration before it affects normal operation, proceed to step 5.

5. Start engine if not already running.
6. Push the control bar down to its lowest position, cocking the mechanism (Fig. 11).
7. Slowly lift the control bar to a point where the bag just begins to inflate (about 5" below the handle). This indicates that the mower blade is engaged and has begun to rotate.

Note: This intermediate position is not the "natural" operating position of the control bar. However, it has proven to be useful in early detection of latent BBC sticking which could create an unsafe condition later in the life of the mower.

8. Release the control bar.

Note: If a "bang" is heard and the bag immediately deflates, the control bar had been raised too far. Repeat steps 6, 7 & 8, but do not raise the handle as high as in step 7.

If the control bar "hangs up" and the blade does not quickly stop, it indicates possible deterioration has set in, which could result in an unsafe operating condition. Have mower inspected by an Authorized TORO Service Dealer.

CAUTION: If the control bar "hangs up", and the blade does not stop quickly, you should stop the blade before shutting off the engine. This can be done by raising the control bar to the normal operating position and releasing it.

MAINTENANCE

CAUTION

Pull wire off spark plug before performing adjustments or maintenance.

SERVICING AIR CLEANER

Normally, replace air cleaner after every 25 operating hours. More frequent replacement is required when mower is operated in dusty or dirty conditions.

1. Stop engine and pull wire off spark plug (Fig. 12).

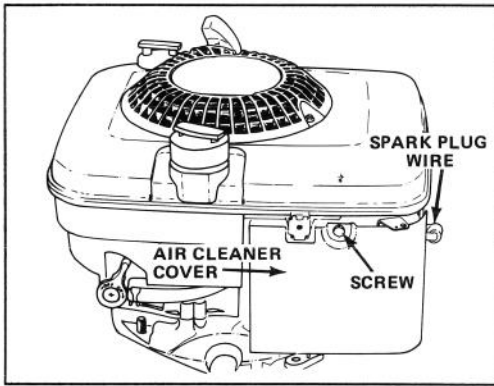

Figure 12

2. Remove screw securing air cleaner cover to engine (Fig. 12). Tilt cover down and clean thoroughly.
3. Remove paper air cleaner filter (Fig. 13) and discard.

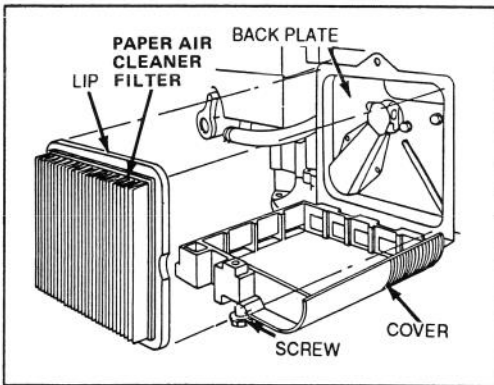

Figure 13

4. Insert new paper air cleaner filter cartridge so lip touches back plate as shown in Fig. 13.
5. Replace air cleaner cover and secure with screw.

REPLACING SPARK PLUG

Use a Champion RCJ8, a Champion RJ19LM or Autolite 245 spark plug or equivalent. Correct air gap is 0.030" (0.76 mm). Remove plug after every 25 operating hours and check its condition.

1. Stop engine and pull wire off spark plug (Fig. 12).
2. Clean around spark plug and remove plug from cylinder head.

IMPORTANT: Replace a cracked, fouled, or dirty spark plug. Do not sand blast, scrape, or clean electrodes because engine damage could result from grit entering cylinder.

3. Set air gap at 0.030" (0.76 mm) (Fig. 14). Install correctly gapped spark plug and gasket seal. Tighten plug firmly to 15 ft-lb (20.4 N·m).

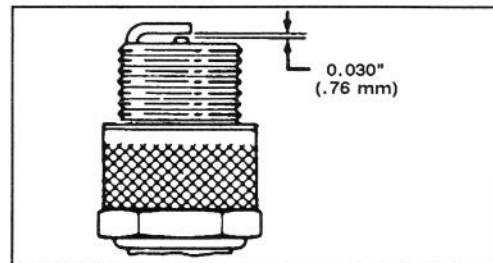

Figure 14

DRAINING GASOLINE

1. Stop engine and pull wire off spark plug (Fig. 12).

NOTE: Drain fuel from a cold engine only.

2. Move fuel shut-off valve to OFF position (Fig. 15).

3. Remove cap from fuel tank and use pump-type syphon to drain fuel into clean gas can.

NOTE: This is the only procedure recommended for draining fuel.

MAINTENANCE

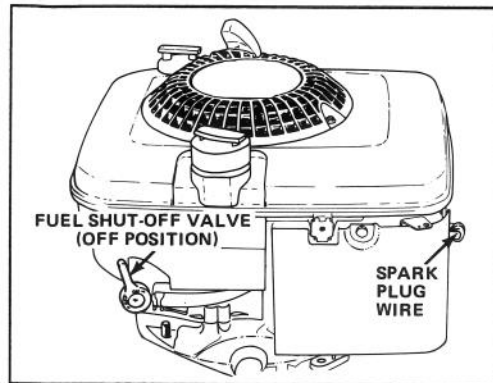

Figure 15

CHANGING CRANKCASE OIL

Many mowers equipped with blade brake clutch (BBC) systems require that the engine oil be drained through the oil fill tube. Change oil after the first 2 operating hours and after every 25 hours thereafter. The oil should be hot to provide for best flow of oil and contaminants from the engine. Also, the fuel tank should be no more than half full.

Note: Determine left and right sides of mower by standing in normal operator's position.

1. Stop engine and pull wire off spark plug (Fig. 17).
2. Place mower on a flat surface.
3. Place drain container next to right side of mower. For best results, use a flat, shallow pan (Fig. 16).
4. Remove dipstick from oil fill tube.
5. Tip mower on its right side, and rest it on handle and wheels (Fig. 16).
6. Allow oil to drain from oil fill tube.

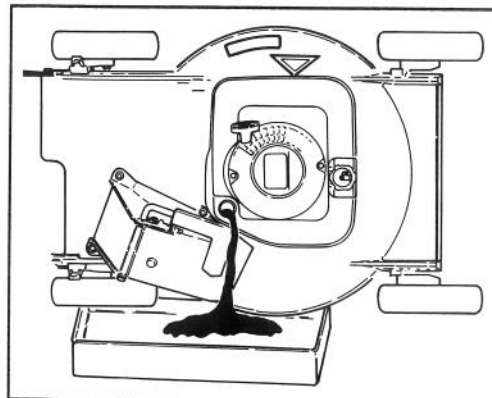

Figure 16

7. Tip mower back on all four wheels. Wipe up any spilled oil.
8. Add approximately 8 ounces of 10W30 oil. Continue to add and check the oil until the level reaches the full mark on the dipstick.
9. Reinstall the dipstick.

ADJUSTING THROTTLE

Throttle control adjustment may be required if engine does not start or stop. Whenever a new throttle control cable is installed, throttle must be adjusted.

1. Stop engine and pull wire off spark plug (Fig. 17).
2. Move throttle control to FAST.

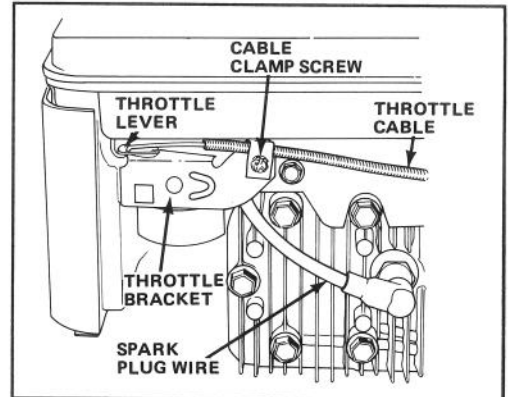

Figure 17

3. Loosen cable clamp screw until throttle cable slides (Fig. 17). Align holes in throttle lever and throttle bracket using a 1/8" diameter drill (Fig. 18). Tighten cable clamp screw to lock adjustment in place.

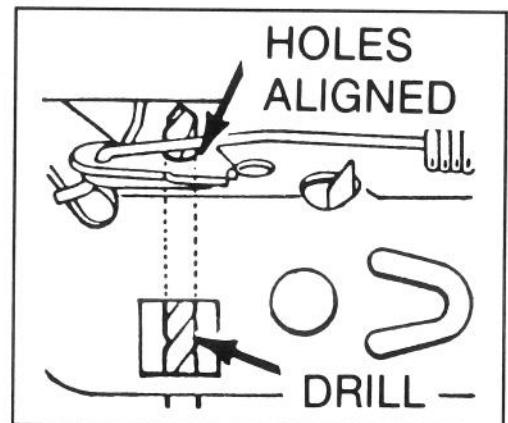

Figure 18

MAINTENANCE

ADJUSTING WHEEL DRIVE

If mower does not self-propel or has a tendency to creep forward when drive is not engaged, adjust wheel drive control knob on rear of gear box.

1. Close door on mower housing and remove bag.
2. ADJUSTMENT (Fig. 19) – Rotate control knob clockwise 1/2 turn if mower does not self-propel. If mower creeps forward, rotate knob 1/2 turn counterclockwise to loosen belt.

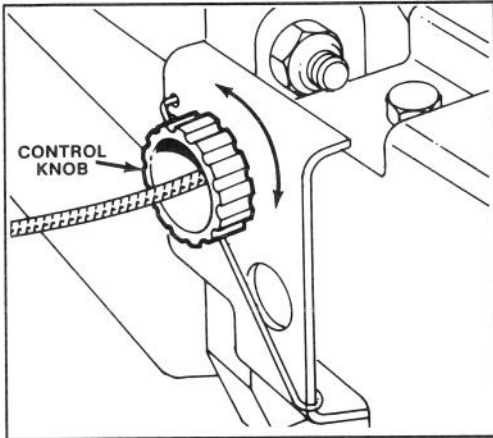

Figure 19

3. CHECK ADJUSTMENT – Slowly pull mower backwards while control bar is gradually moved toward handle. Adjustment is correct when rear wheels stop turning and control bar is about 1 inch from handle (Fig. 20).

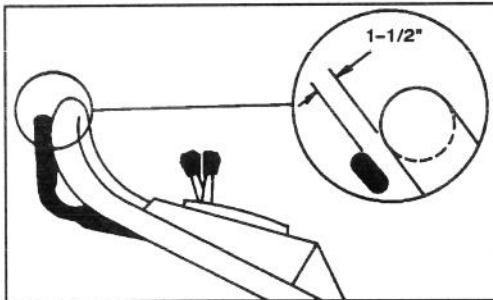

Figure 20

4. Repeat steps 2 and 3 until properly adjusted.

INSPECTING/REMOVING/SHARPENING BLADE

1. Stop engine and pull wire off spark plug (Fig. 17).

2. Drain gasoline from fuel tank; refer to Draining Gasoline, page 8.
3. Tip mower on its right side (Fig. 21). Avoid rotating blade because starting problems may result.

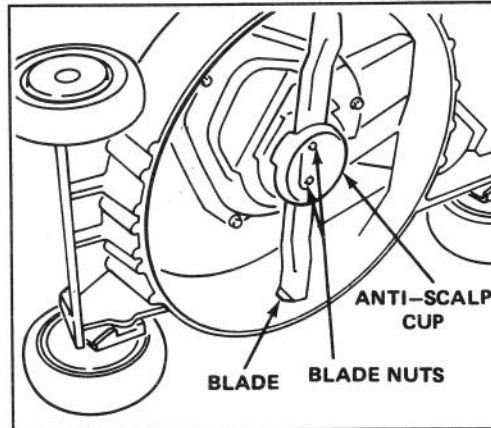

Figure 21

4. INSPECTING BLADE – Carefully examine blade for sharpness and wear, especially where flat and curved parts meet (Fig. 22A). Since sand and abrasive material can wear away the metal that connects the flat and curved parts of the blade, check blade before using the mower. If a slot or wear is noticed, (Fig. 22B & C), replace blade. Refer to step 5.

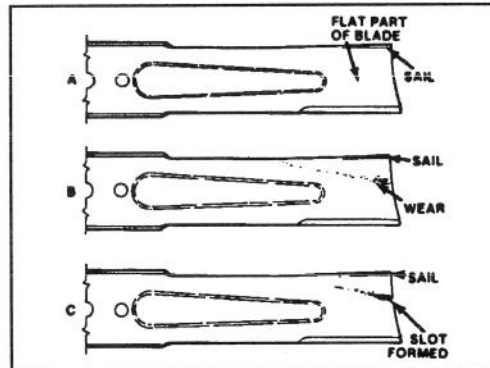

Figure 22

Note: For optimum performance, install new blade before cutting season begins. During the year, file down small nicks to maintain the cutting edge.

MAINTENANCE

CAUTION

If blade is allowed to wear, a slot may form near the sail. Eventually a piece of blade may break off resulting in serious injury to yourself or a bystander.

5. REMOVING BLADE—Grasp end of blade using a rag or thickly padded glove. Remove blade nuts, anti-scalp cup, blade, and spacer (Fig. 23).

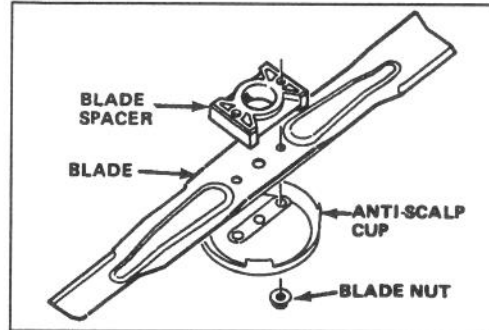

Figure 23

6. SHARPENING BLADE—Using a file, sharpen top side of blade and maintain original cutting angle (Fig. 24). The blade will remain balanced if same amount of material is removed from both cutting edges.

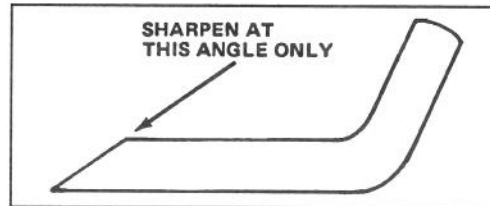

Figure 24

IMPORTANT: Check balance of blade by putting it on a blade balancer. An inexpensive balancer can be purchased at a hardware store. A balanced blade stays in a horizontal position and an unbalanced blade settles to the heavy side. If blade is not balanced, file more metal off cutting edge on heavy end of blade.

7. Install sharp, balanced blade and anti-scalp cup with blade nuts. Sail part of blade must point toward top of mower housing to assure correct installation. Tighten the blade nuts to 20–35 ft-lb.

LUBRICATION

After every 25 operating hours or when season ends, front and rear wheels must be lubricated.

1. Apply 2 or 3 drops of light oil on inside of front and outside of all wheel bolts. Spin wheels to distribute oil into bushings. Wipe up excess oil.
2. Move rear wheel height-of-cut levers to "C" setting. Wipe grease fittings with clean rag (Fig. 25). Install grease gun onto fitting and gently apply 2 or 3 pumps of #2 Multi-Purpose Lithium Base Grease.

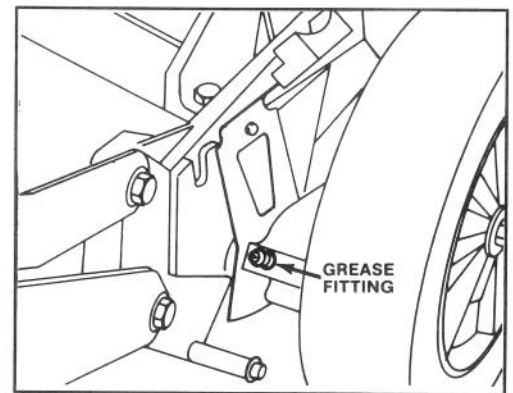

Figure 25

ADJUSTING BLADE BRAKE

Whenever a new blade brake cable assembly is installed, an adjustment is required.

1. Stop engine and pull wire off spark plug (Fig. 12).
2. Loosen cable clamp screw until brake cable conduit slides (Fig. 26). Pull cable to remove slack, but do not put tension on spring. Tighten screw to lock adjustment in place.

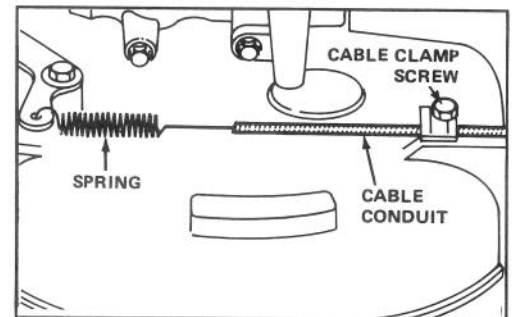

Figure 26

MAINTENANCE

ADJUSTING GROUND SPEED CONTROL FOR NEUTRAL

Whenever a new ground speed control cable is installed or if mower drives when ground speed control is in "N", an adjustment is required.

1. Stop engine and remove grass bag.
2. Remove two capscrews and lift off transmission cover (Fig. 27).

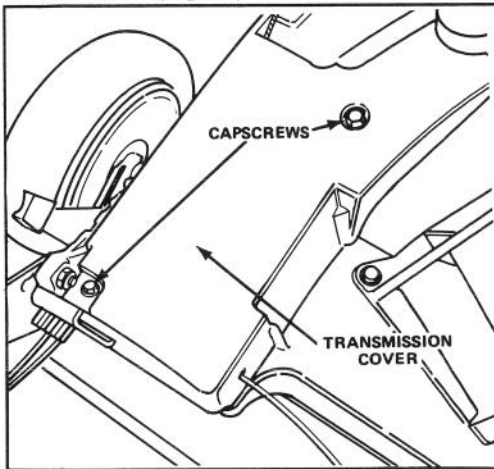

Figure 27

4. ADJUSTMENT (Fig. 28) — Loosen cable clamp screw until cable conduit slides. Move ground speed control to "N" position. Push transmission control lever toward stop until you feel a "snap". The transmission control lever should be close to the stop when the snap is felt. Pull cable to remove any slack and tighten cable clamp screw.

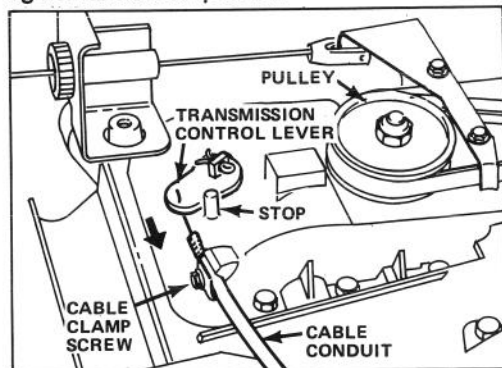

Figure 28

5. CHECK ADJUSTMENT — Assure ground speed control is in "N" and pull mower backward. Pulley (Fig. 28) should not rotate. If pul-

ley does rotate, readjust for neutral: refer to step 4.

6. Reinstall transmission cover and grass bag.

CLEANING BLADE BRAKE CLUTCH SHIELD

The BBC (Blade Brake Clutch) shield should be cleaned periodically, at the end of each mowing season at minimum, to assure optimum performance and to prevent part degradation.

1. Stop engine and pull wire off spark plug (Fig. 17).
2. Drain gasoline from fuel tank; refer to Draining Gasoline, page 8.
3. Tip mower on its right side.
4. Remove (2) blade nuts, anti-scalp cup, blade, blade spacer, and (3) bolts and washers securing BBC shield to mower deck (Fig. 29).

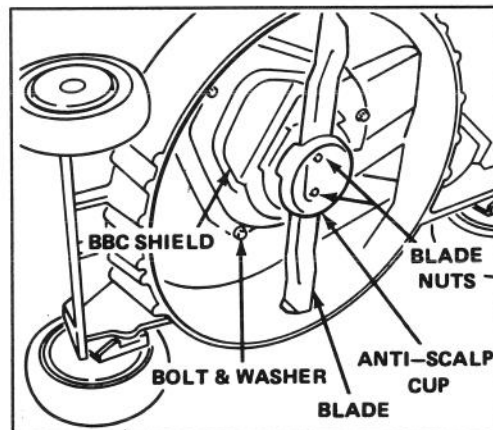

Figure 29

5. Brush or blow debris from inside of shield.
6. Reinstall BBC shield with (3) bolts and washers, blade spacer, blade, anti-scalp cup, and (2) blade nuts.
7. Replace spark plug wire.

CLEANING MOWER HOUSING

To assure optimum performance, keep underside of mower housing and inside of discharge area clean.

1. Drain gasoline from fuel tank: refer to Draining Gasoline, page 8.
2. Tip mower on its right side (Fig. 30). Avoid rotating blade because starting problems may result.

MAINTENANCE

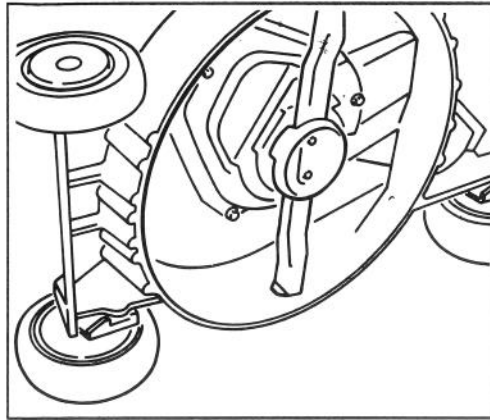

Figure 30

3. Remove dirt and grass clippings that stick to housing by spraying it with a garden hose. Scrape out remaining debris with hardwood scraper. Avoid burrs and sharp edges.

PREPARING MOWER FOR STORAGE

1. Turn fuel shut-off valve to OFF position to prevent fuel leakage from the carburetor.
2. For long term storage, either drain gasoline from fuel tank or add a fuel additive to the gasoline. To drain gasoline, refer to Draining Gasoline, pages 8-9. After fuel is drained, start engine and let it idle until all fuel is consumed and engine stops. If gasoline is not drained and an isopropyl alcohol based fuel additive is not added, gum-like varnish deposits will form and cause poor engine operation, even starting problems.

Fuel can be left in gas tank only if an isopropyl alcohol based fuel additive such as Toro's Preservit is added to gasoline before storing. Use fuel additive in recommended quantities as specified on container.

3. Drain oil: refer to Changing Crankcase Oil, page 9. After oil is drained, do not fill crankcase with oil until the following steps (3-9) are completed.

4. Remove spark plug and pour 2 table-spoons of SAE 10W30 oil into hole in cylinder. Pull starter rope slowly to coat inside of cylinder. Install spark plug and tighten to 15 ft-lb (20.4 N·m). **DO NOT INSTALL WIRE ON SPARK PLUG.**

5. Clean mower housing: refer to Cleaning Mower Housing, pages 12-13.

6. Clean BBC shield: refer to Cleaning Blade Brake Clutch Shield, page 12.

7. Check condition of blade: refer to Inspecting/Removing/Sharpening Blade, pages 10-11.

8. Tighten all nuts, bolts, and screws.

9. Clean dirt and chaff from cylinder, cylinder head fins, and blower housing. Also remove grass clippings, dirt, and grime from external parts of the engine, shrouding, and top of mower housing.

10. Clean air cleaner: refer to Servicing Air Cleaner, page 8.

11. Lubricate the wheels: refer to Lubrication, page 11.

12. Touch up all rusted or chipped paint surfaces. Toro Re-Kote paint is available from an Authorized TORO Service Dealer.

13. Fill crankcase with oil; refer to Fill Crankcase With Oil, pages 3-4.

14. Store mower in a clean, dry place. Cover mower to keep it clean and protected.

OPTIONAL EQUIPMENT

For special conditions the following accessories may be purchased at your local authorized TORO Service Dealer.

1. Side Discharge Kit, Model No.

59168 — Installs in seconds. Rear mounted in place of the grass bag. Disperses clippings while trimming on both sides (Fig. 31).

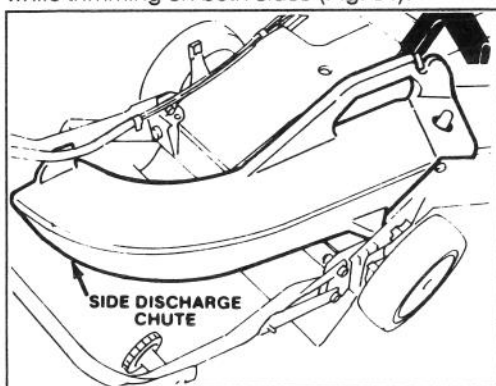

Figure 31

2. Dethatcher Kit, Model No. 59131 — Installs in minutes. Front mounted for easy maneuverability. Spring tines loosen thatch for clean vacuuming into grass bag (Fig. 32) and convenient disposal.

3. Leaf Shredder Kit, Model No. 59180 — Installs on underside of mower in minutes without requiring removal of blade. Shreds leaves into small pieces for clean vacuuming into grass bag and convenient disposal (Fig. 33).

4. Spark Arrestor, Briggs & Stratton Part No. 396800 — If a spark arrestor is required because of local, state, or federal regulations,

it may be purchased at your local Authorized Briggs & Stratton Service Dealer. If mower is operated on any California forest, brush, or grass covered land without a properly operating spark arrestor, the operator is violating state law, Section 4442 Public Resources Code.

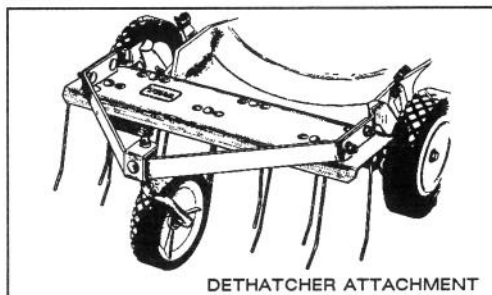

Figure 32

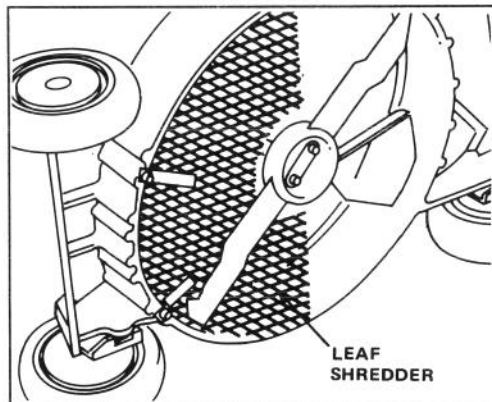

Figure 33

TORO SERVICE SUPPORT

If help — concerning safety, set-up, operation, maintenance, or troubleshooting — is ever needed, contact the local Authorized TORO Service Dealer or Distributor. Refer to the “Yellow Pages” for assistance. In addition to skilled service technicians, the dealer and distributor have factory approved accessories and replacement parts. Keep your Toro all TORO. Buy genuine TORO replacement parts and accessories.

PRODUCT IDENTIFICATION

A model and a serial number decal is located at rear of mower housing, near the discharge door. Always refer to specific numbers on this decal in correspondence or when replacement parts are needed.

MAINTENANCE RECORD

Date	Hours Used	Oil Change	Air Cleaner Service	Lubrication	Spark Plug	Winter Storage

The Toro Promise
A Two Year Limited Warranty
On All
Gasoline Powered Consumer Products

The Toro Company promises to repair these TORO Products if defective in materials or workmanship. The following time periods from the date of purchase apply:

Residential Product 2 Years
Residential Products Used Commercially 45 Days

The cost of parts and labor are included, but the customer pays the transportation costs. Just return any residential product to an Authorized TORO Service Dealer or TORO Distributor.

Should you feel your TORO Product is defective and wish to rely on The Toro Promise, you may return it to:

1. Contact any Authorized TORO Service Dealer, TORO Master Service Dealer, or TORO Distributor. (The Yellow Pages of your telephone directory is a good reference source).
2. He will either instruct you to return the product to him or recommend another Authorized TORO Service outlet which might be more convenient.
3. Bring the product along with your original sales slip, or other evidence of purchase date, to the service dealer.
4. The servicing dealer will inspect the unit, advise you whether the product is defective and, if so, make all repairs necessary to correct the defect without any extra charge to you.

If for any reason you are dissatisfied with the analysis of the defect or the service performed, you may contact us.

Write: TORO Customer Service Dept.
8111 Lyndale Avenue South
Minneapolis, MN 55420

The above remedy of product defects through repair by an Authorized TORO Service Dealer is the purchaser's sole remedy for any defect.

THERE IS NO OTHER EXPRESS WARRANTY. ALL IMPLIED WARRANTIES OF MERCHANTABILITY AND FITNESS FOR USE ARE LIMITED TO THE DURATION OF THE EXPRESS WARRANTY.

Some states do not allow limitations on how long implied warranty lasts, so the above limitation may not apply to you.

This warranty applies only to parts or components which are defective and does not cover repairs necessary due to normal wear, misuse, accidents, or lack of proper maintenance. Regular, routine maintenance of the unit to keep it in proper operating condition is the responsibility of the owner.

All warranty repairs reimbursable under The Toro Promise must be performed by an Authorized Toro Service Dealer using Toro approved replacement parts.

Repairs or attempted repairs by anyone other than an Authorized TORO Service Dealer are not reimbursable under the TORO Promise. In addition, these unauthorized repair attempts may result in additional malfunctions, the correction of which is not covered by warranty.

THE TORO COMPANY IS NOT LIABLE FOR INDIRECT OR CONSEQUENTIAL DAMAGES IN CONNECTION WITH THE USE OF THE PRODUCT.

Some states do not allow the exclusion of incidental or consequential damages, so the above exclusion may not apply to you.

This warranty gives you specific legal rights, and you may also have other rights which vary from state to state.

COUNTRIES OTHER THAN THE UNITED STATES OR CANADA

Customers who have purchased TORO products exported from the United States or Canada should contact their TORO Distributor (Dealer) to obtain guarantee policies for your country, province, or state. If for any reason you are dissatisfied with your Distributor's service or have difficulty obtaining guarantee information, contact the TORO importer. If all other remedies fail, you may contact us at The Toro Company.