

MODEL NO. 30718 — 00001 & UP

**OPERATOR'S
MANUAL**
PROLINE 118

The PROLINE 118 conforms to the American National Standards Institute's safety standards for riding mowers; thus, Toro proudly displays the ANSI safety seal.



To assure maximum safety, optimum performance, and to gain knowledge of the machine, it is essential that you or any other operator of the machine read and understand the contents of this manual before the engine is started. Pay particular attention to the instructions highlighted by the triangular safety alert symbol. Failure to comply with the safety instructions may result in personal injury.



FOREWORD

The PROLINE 118 was developed to satisfy the demand for a maneuverable, intermediate size, turf maintenance rotary mower. The machine has advanced concepts in engineering, design and safety; and if maintained properly, it will give excellent service.

Since the PROLINE 118 is a high-quality product, Toro is concerned about the future use of the machine and safety of the user. Therefore, read this manual to familiarize yourself with proper set-up, operation and maintenance instructions. The major sections of the manual are:

1. Safety Instructions
2. Set-Up Instructions
3. Before Operating
4. Operating Instructions
5. Maintenance

The engine, hydrostatic transmission and axle are not covered in great detail in this manual. However, service manuals are available from the respective manufacturers. An engine service manual can be obtained from:

Kohler Company
Kohler, Wisconsin 53044

A hydrostatic axle service manual can be obtained from:

Tecumseh Products Company
900 North Street
Grafton, Wisconsin 53024

And a hydrostatic transmission service manual and a repair manual can be obtained from:

Eaton Corporation
15151 — Highway 5
Eden Prairie, Minnesota 55344

Certain information in this manual is emphasized. DANGER, WARNING and CAUTION identify personal safety-related information. IMPORTANT identifies mechanical information demanding special attention. Be sure to read the directive because it deals with the possibility of damaging a part or parts of the machine. NOTE identifies general information worthy of special attention.

OPTIONAL SPARK ARRESTER

In some areas there are local, state or federal regulations requiring that a spark arrester be used on the engine of this mower. If a spark arrester is required, order the parts from your local Authorized Toro ProLine Service Dealer.

The parts are approved by the United States Department of Agriculture and Forestry.

When mower is used or operated on any California forest, brush or grass covered land, a working order spark arrester must be attached to muffler. If not, the operator is violating state law, Section 4442 Public Resources Code.

If help concerning set-up, operation, maintenance or safety is ever needed, contact the local Authorized TORO Proline Service Dealer. In addition to the genuine TORO replacement parts, the dealer also has optional equipment for the complete line of TORO turf care equipment. Keep your Toro all TORO. Buy genuine TORO replacement parts and accessories.

TABLE OF CONTENTS

	Page		Page
SAFETY INSTRUCTIONS	4-5	Adjusting Steering	17
SAFETY AND INSTRUCTION DECALS	6	Changing Crankcase Oil	17
SPECIFICATIONS	7	Servicing Air Cleaner	17
LOOSE PARTS	8	Cleaning Cylinder Head Fins	18
SET-UP INSTRUCTIONS	8-9	Adjusting Carburetor	18
Install Standard Seat	8	Adjusting Throttle Control	19
Install Deluxe Seat	9	Adjusting Choke Control	19
Install Steering Wheel	9	Replacing Fuel Filter	19
Check Tire Pressure	9	Checking and Replacing Spark Plugs	19
BEFORE OPERATING	10-11	Servicing Battery	20
Activate and Charge Battery	10	Wiring Harness Service	20
Reinstall Battery	10	Adjusting Transmission for Neutral	20
Check Crankcase Oil	10	Changing Hydraulic Oil Filter	21
Check Hydraulic System Fluid	11	Changing Hydraulic System Oil	21
Fill Fuel Tank with Gasoline	11	Adjusting Lift Cylinder And Counterbalance Springs	22
CONTROLS	12-13	Adjusting or Replacing Belts	22
OPERATING INSTRUCTIONS	14-15	Hydraulic Schematic	24
Starting/Stopping Engine	14	Electrical Schematic	25
Checking Operation of Interlock Switches	14	PREPARATION FOR SEASONAL STORAGE	26
Operating Characteristics	14	PRODUCT IDENTIFICATION	26
Pushing Traction Unit	15	MAINTENANCE RECORD	27
LUBRICATION	15-16	THE TORO PROMISE	Back Cover
MAINTENANCE	16		
Parking Brake Adjustment	16		

SAFETY INSTRUCTIONS

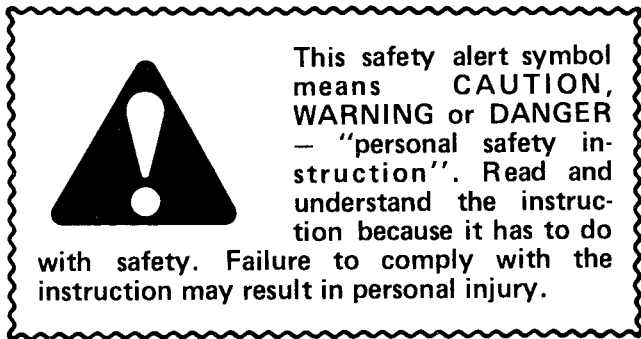

Improper use or maintenance of the machine can result in injury. To reduce the potential for injury, comply with the following safety instructions.

BEFORE OPERATING

1. Read and understand the contents of this Operator's Manual before starting and operating the machine. Become familiar with all controls and how to stop quickly. A replacement manual is available by sending complete Model and Serial Number to:

The Toro Company
8111 Lyndale Avenue South
Minneapolis, Minnesota 55420

2. Never allow children or adults unfamiliar with it's operation to operate the machine, and keep everyone, especially children and pets, away from the area of operation.

3. Remove sticks, stones, wire and any other debris or objects that might be picked up and thrown by the cutter blades.

4. Keep all shields and safety devices in place. If a shield, safety device or decal is defective or damaged, repair or replace it before operation is commenced. Also, tighten any loose nuts, bolts and screws to make sure machine is in safe operating condition.

5. Do not operate machine while wearing sandals, tennis shoes, sneakers or shorts. Also, do not wear loose fitting clothing because it could get caught in moving parts. Always wear long pants and substantial shoes. Wearing safety glasses, safety shoes and a helmet is advisable and required by some local ordinances and insurance regulations.

6. Be sure interlock switches are adjusted correctly so engine cannot be started unless traction pedal is released — neutral position — and PTO switch is in DISENGAGE position.

7. Fill fuel tank with gasoline before starting the engine. Avoid spilling any gasoline. Since gasoline is highly flammable, handle it carefully — DO NOT SMOKE.

- A. Use an approved gasoline container.
- B. Do not fill tank while engine is hot or running.
- C. Do not smoke while handling gasoline.
- D. Fill fuel tank outdoors and up to about one inch (25 mm) from top of the tank, not the filler neck. **KEEP HOOD CLOSED** when filling.
- E. Wipe up any spilled gasoline. Install gasoline container cap and machine fuel tank cap securely before starting the engine.

WHILE OPERATING

8. Do not run the engine in a confined area without adequate ventilation. Exhaust fumes are hazardous and could possibly be deadly.

9. Maximum seating capacity is one person. Never carry passengers.

10. Sit on the seat when starting the engine and operating the machine.

11. When starting the engine:

- A. Engage parking brake.
- B. Be sure traction pedal is in neutral and PTO is in disengage position.
- C. After engine is started, release parking brake and keep foot off traction pedal. Machine must not move. If movement is evident, the neutral return mechanism is adjusted incorrectly; therefore, shut engine off and adjust until machine does not move when traction pedal is released. Refer to Adjusting Transmission for Neutral, page 20.

12. Using the machine demands attention, and to prevent loss of control:

- A. Mow only in daylight or when there is good artificial light.
- B. Watch for holes or other hidden hazards.
- C. Do not drive close to a sand trap, ditch, creek or other hazard.
- D. Reduce speed when making sharp turns and when turning on hillsides.
- E. Avoid sudden stops and starts.
- F. Before backing up, look to the rear to be sure no one is behind the machine.
- G. Watch out for traffic when near or crossing roads. Always yield the right-of-way.

SAFETY INSTRUCTIONS

13. The grass deflector must always be installed and in down position on the side discharge cutting unit, except when using optional grass catcher. If the cutting unit discharge area ever plugs, disengage PTO and shut engine off before removing the obstruction.

14. Never raise the cutting unit while the blades are rotating.

15. If the cutting blades strike a solid object or the machine vibrates abnormally, disengage PTO, move throttle to SLOW, set parking brake and shut engine off. Remove key from switch and disconnect high tension wires from spark plugs to prevent possibility of accidental starting. Check cutting unit and traction unit for damage and defective parts. Make all repairs before restarting the engine and operating the cutting unit. Make sure blades are in good condition and blade nuts are tight.

16. Cut grass slopes carefully. When going uphill or downhill do not start or stop suddenly.

17. Do not touch engine, muffler or its adjacent shroud while engine is running or soon after it is stopped because these areas could be hot enough to cause a burn.

18. Lower the cutting unit or other attached implement to the ground and remove key from switch whenever machine is left unattended.

19. Before getting off the seat:

- A. Move traction pedal to neutral position and remove foot from pedal.
- B. Set the parking brake and disengage the PTO.
- C. Shut the engine off and remove key from ignition switch. Wait for all movement to stop before getting off the seat.

MAINTENANCE

20. Remove key from ignition switch and disconnect high tension wire from spark plug to prevent accidental starting of the engine when servicing, adjusting or storing the machine.

21. Perform only those maintenance instructions described in this manual. If major repairs are ever needed or assistance is desired, contact an Authorized TORO Distributor. Ask about Mobile Service Maintenance.

22. To reduce potential fire hazard, keep the engine free of excessive grease, grass, leaves and accumulations of dirt.

23. Be sure machine is in safe operating condition by keeping nuts, bolts and screws tight. Check the blade mounting nuts frequently to be sure they are tight.

24. Make sure all hydraulic line connectors are tight, and all hydraulic hoses and lines are in good condition before applying pressure to the system.

25. Keep body and hands away from pin hole leaks or nozzles that eject hydraulic fluid under high pressure. Use paper or cardboard, not hands, to search for leaks. Hydraulic fluid escaping under pressure can have sufficient force to penetrate skin it must be surgically removed within a few hours by a doctor familiar with this form of injury or gangrene may result.

26. Before disconnecting or performing any work on the hydraulic system, all pressure in system must be relieved by stopping engine and lowering implement to the ground.

27. If the engine must be running to perform a maintenance adjustment, keep hands, feet, clothing and other parts of the body away from the cutting unit blades and other moving parts.

28. Do not overspeed the engine by changing governor settings. Maximum engine speed (with engine coupled to transmission) is 3100-3300 rpm. To ensure safety and accuracy, have an Authorized TORO Distributor check maximum engine speed with a tachometer.

29. Engine must be shut off before checking oil or adding oil to the crankcase.

30. At the time of manufacture, the PROLINE 118 conformed to safety standards in effect for riding mowers. Therefore, to assure optimum performance and safety, always purchase genuine TORO replacement parts and accessories. Replacement parts and accessories made by other manufacturers could be dangerous. Such use could void the product warranty of The Toro Company.

CAUTION

1. KEEP ALL SHIELDS IN PLACE.
2. BEFORE LEAVING OPERATOR'S POSITION.
 - A. MOVE TRANSMISSION TO NEUTRAL.
 - B. DISENGAGE ATTACHMENT CLUTCH.
 - C. SET PARKING BRAKE.
 - D. SHUT OFF ENGINE.
 - E. REMOVE IGNITION KEY.
3. WAIT FOR ALL MOVEMENT TO STOP BEFORE SERVICING MACHINE.
4. KEEP BYSTANDERS FROM AREAS BEING MOWED.



SAFETY AND INSTRUCTION DECALS

The following decals are installed on the machine. If any become damaged or illegible, replace it. The decal part number is listed below and in your parts catalog. Replacement can be ordered from your Authorized Toro Distributor.



ON SIDE PANEL
(Part No. 54-0910)

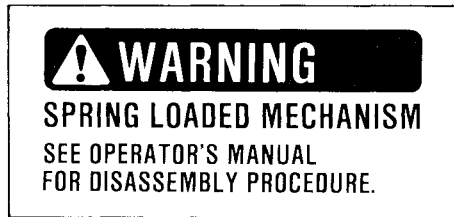

ON LIFT ARMS AND IDLER LEVER
(Part No. 55-4300)

CAUTION
CHECK PERFORMANCE OF ALL INTERLOCK SWITCHES DAILY. DO NOT DEFEAT INTERLOCK SYSTEM. IT IS FOR YOUR PROTECTION. READ AND UNDERSTAND OPERATORS MANUAL BEFORE OPERATING THIS MACHINE.

1. DISENGAGE IMPLEMENT BEFORE RAISING TO TRANSPORT POSITION.
2. DO NOT OPERATE IMPLEMENT IN TRANSPORT POSITION.
3. KEEP ALL SHIELDS IN PLACE.
4. BEFORE LEAVING OPERATOR'S POSITION.
 - A. MOVE TRANSMISSION TO NEUTRAL.
 - B. SET PARKING BRAKE.
 - C. DISENGAGE POWER TAKE-OFF.
 - D. SHUT OFF ENGINE.
 - E. REMOVE IGNITION KEY.
5. WAIT FOR ALL MOVEMENT TO STOP BEFORE SERVICING.
6. STOP ENGINE BEFORE ADDING FUEL OR LIFTING HOOD.
7. KEEP PEOPLE AND PETS A SAFE DISTANCE AWAY FROM MACHINE.

REPLACEMENT MANUAL AVAILABLE BY SENDING COMPLETE MODEL NUMBER TO: THE TORO CO., 8111 LYNDALE AVE. MINNEAPOLIS, MN 55420.

TRACTION PEDAL INSTRUCTIONS



THE MORE THE PEDAL IS DISPLACED, THE FASTER THE VEHICLE SPEED.

ON FLOOR PANEL
(Part No. 54-0880)

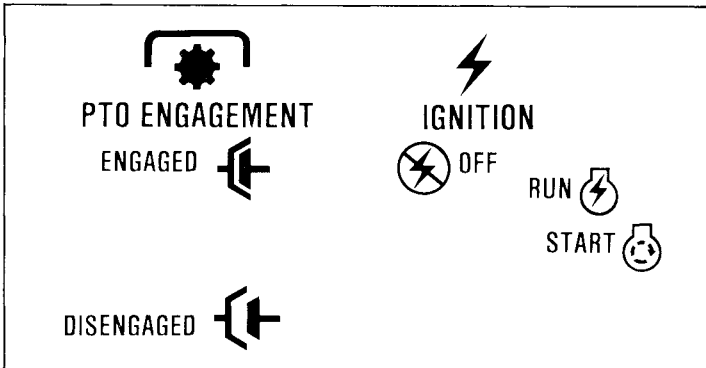

REAR OF STEERING TOWER
(Part No. 54-0870)



ON SIDE PANELS
(Part No. 54-0890)

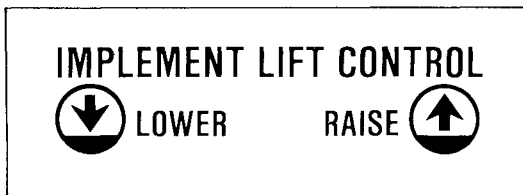

ON SEAT PLATE
(Part No. 54-0900)

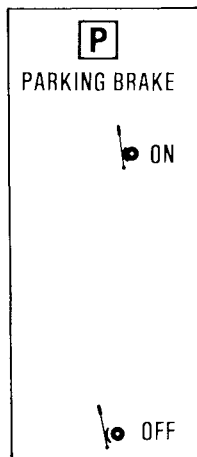

FRONT OF SEAT SUPPORT
(Part No. 54-0920)

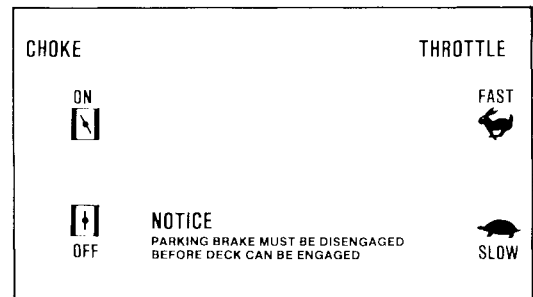

TOP OF STEERING TOWER
(Part No. 54-0860)

SPECIFICATIONS

Engine:

Manufacturer — Kohler
Horsepower — 18 @ 3600 RPM.
Torque — 28.5 lb-ft @ 2300 RPM.
Displacement — 42.18 cu. in.
Crankcase Capacity — 3 Pints
Governor — Mechanical.
Governor Limit — 3100-3300 RPM.
Idle Speed — 1700-1800 RPM.
Spark Plug — Champion RV-15YC
Air Gap — 0.025 in.

Air Cleaner: Dual element dome style with remote air intake.

Fuel Tank Capacity: 5 gal.

Electrical:

Battery — 12 volt.
Alternator — 15 amp.

Drive Coupling: Direct belt drive from engine PTO to transmission input spring, tensioned idler.

Transmission:

Manufacturer & Model — Eaton hydrostatic — Model 11. Provides infinitely variable control of speed, direction, and dynamic braking with a single control.

Hydraulic Filter: 10 micron remote mounted spin-on type.

Drive Axle: Manufacturer — Peerless, Model 1310. Mates directly with transmission.

Tires, Wheels, Pressure:

Wheels — demountable type.
Front Tires — 18 x 6.50 x 8.
Rear Tires — 13 x 5.00 x 6.
All tires 4 ply rating, tubeless type.
(Pressure — 10-15 psi (69-103 kPa).

Steering: 15 in. (38 cm) steering wheel. Automotive type steering.

Main Frame: Bolt together frame consists of welded steel, formed steel, and square tubing components.

Controls: Throttle, choke, PTO switch, parking brake, implement lift and ignition switch are all hand-operated. Traction pedal is foot operated.

PTO Drive: Direct belt drive from electric clutch mounted on engine PTO to front mounted jack-shaft. Spring tensioned idler.

Implement connection — front implements bolt onto two front push arms.

Lift Cylinders: One, with 1-1/2 in. bore, 5-1/2 in. stroke.

Control Valve: Equipped with load check valves to prevent settling of implement and 800 PSI relief valve.

Interlock Switches: Prevents engine starting if traction pedal or PTO levers are engaged. Stops engine if operator leaves seat with either traction pedal or PTO levers engaged.

Dimensions and Weight (approx):

Traction Unit	Length: 71-1/4 in.
	Width: 40-1/2 in.
	Height: 48-1/4 in.
	Weight: 700 lb.

OPTIONAL EQUIPMENT:

44" Side Discharge Cutting Unit —
Model No. 30544

52" Side Discharge Cutting Unit —
Model No. 30753

52" Rear Discharge Cutting Unit —
Model 30768

Cushion Seat — Model No. 30746.

Deluxe Seat — Model No. 30756.

Hour Meter Kit — Part No. 55-8450.

Remote Air Cleaner — Part No. 55-8460.

Grass Collection System — Model No. 30751 (44").

Grass Collection System — Model No. 30576 (52").

Brake Kit — Model No. 30558.

Floatation Kit — Model No. 30759.

Spark Arrestor Muffler — Part No. 53-4580.

44" Snowthrower — Model No. 30761.

Tire Chain Kit — Part No. 56-6630.

Wheel Weight Kit — Part No. 56-6620.

LOOSE PARTS

Note: Use this chart as a checklist to make sure all parts have been received. Without these parts, total set-up cannot be completed.

DESCRIPTION	QTY.	USE
Spacer Steering Wheel Roll Pin 1/4 x 2-1/2 in.	1 1 1	Secure steering wheel.
Capscrews Lockwashers Flatwashers	4 4 4	Install standard seat.
Capscrews Locknuts Jumper Wire R-Clamp	4 4 1 1	Install deluxe seat.
Carriage Bolt Wing Nut	2 2	Connect Battery Cables to Battery.
Operator's Manual Parts Catalog Registration Card Set-Up Report Card	1 1 1 1	

SET-UP INSTRUCTIONS

INSTALL STANDARD SEAT

1. Slide seat switch into opening in seat and clip in place (Fig. 1).

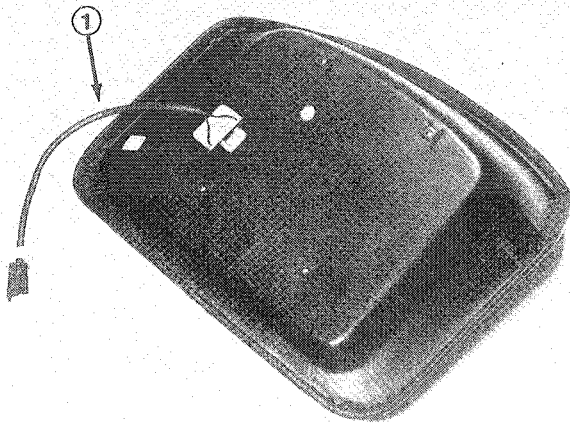

Figure 1
1. Seat switch

2. Position seat onto seat plate aligning mounting holes and routing seat switch wire thru slot (Fig. 2).

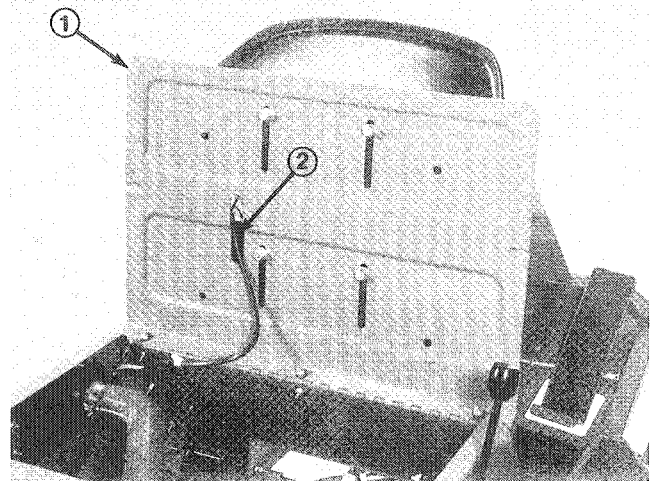

Figure 2

- 1. Seat plate
- 2. Seat switch connector

3. Loosely secure seat to seat plate with (4) capscrews, flatwashers and lockwashers.

4. Adjust seat to desired position, tighten capscrews and plug seat switch connector into wire harness (Fig. 2). Make sure wire harness is clear of lift arm and all moving parts.

SET-UP INSTRUCTIONS

INSTALL DELUXE SEAT

1. Remove shipping ties securing lower seat slide to upper seat slide.
2. Remove lower seat slides and position on seat plate the same way as positioned on seat (Fig. 3).

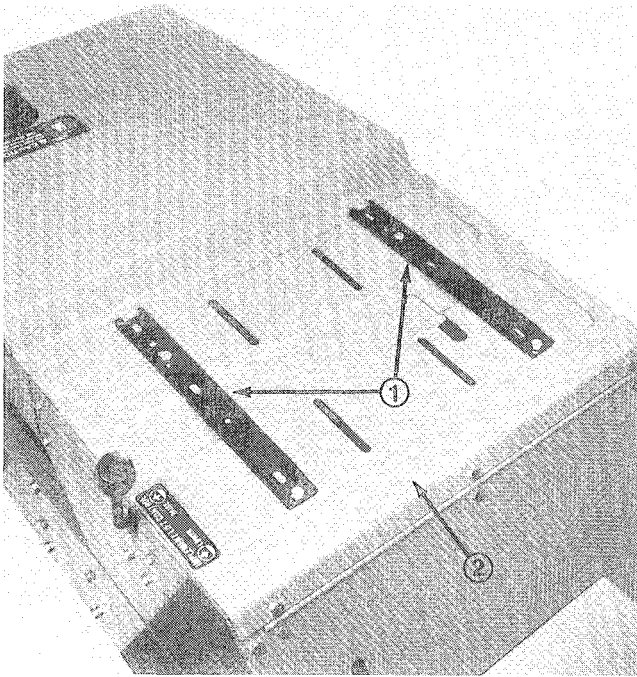

Figure 3

1. Lower seat slides
2. Seat plate

3. Loosely secure lower slides to seat plate with capscrews and locknuts as shown in Fig. 3. Using left rear mounting screw, secure R-Clamp to underside of seat plate (Fig. 4).

4. Slide seat onto slides from front, routing seat switch wire thru left rear slot in seat plate (Fig. 4).

5. Tighten capscrews, and check operation of seat.

6. Route seat switch wire thru R-Clamp, plug into jumper wire and secure jumper wire to wire harness (Fig. 4). Make sure wire harness is clear of lift arm and all moving parts.

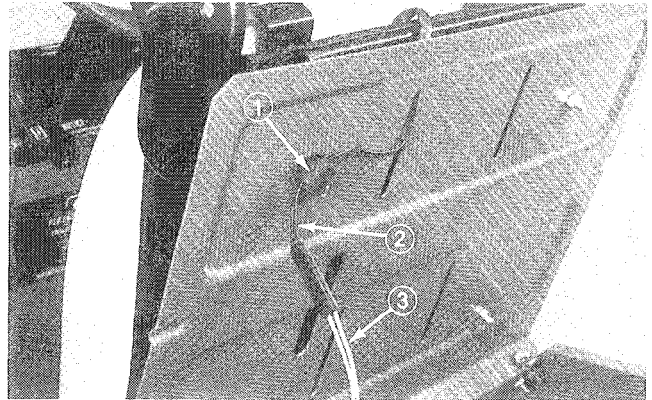

Figure 4

1. R-clamp
2. Seat switch wire
3. Jumper wire

INSTALL STEERING WHEEL

1. Move rear wheels so they point straight ahead.
2. Slide spacer and steering wheel onto steering shaft and assure logo on steering cap points forward.
3. Secure steering wheel in place with roll pin (Fig. 5).

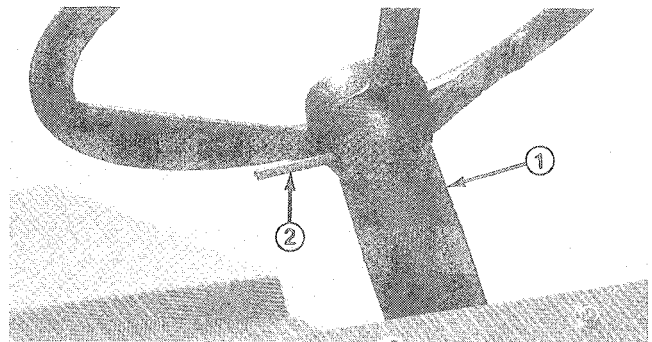

Figure 5

1. Spacer
2. Roll pin

CHECK TIRE PRESSURE

The tires are over-inflated for shipping. Therefore, release some of the air to reduce the pressure. Correct air pressure in front and rear tires is 10 to 15 psi.

BEFORE OPERATING

ACTIVATE AND CHARGE BATTERY

1. Since battery is not filled with electrolyte or activated, bulk electrolyte with 1.260 specific gravity must be purchased from a local battery supply outlet.



CAUTION

Wear safety goggles and rubber gloves when working with electrolyte. Charge the battery in a well ventilated place so gasses produced while charging can dissipate. Since the gasses are explosive, keep open flames and electrical spark away from the battery; do not smoke. Nausea may result if the gasses are inhaled. Unplug charger from electrical outlet before connecting to or disconnecting charger leads from battery posts.

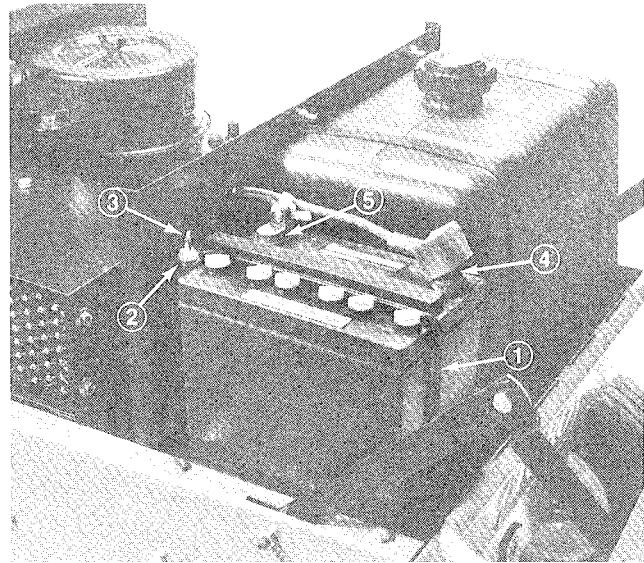

Figure 6

- 1. Clamp
- 2. Support rod
- 3. Wing nut
- 4. Positive battery cable
- 5. Negative battery cable

2. Remove wing nut securing battery support rods and remove battery from machine. Remove filler caps from battery and slowly fill each cell until electrolyte is just above the plates.

3. Replace filler caps and connect a 3 to 4 amp battery charger to the battery posts. Charge the battery at a rate of 3 to 4 amperes for 4 to 8 hours.

4. When battery is charged, disconnect charger from electrical outlet and battery posts.

5. Remove filler caps. Slowly add electrolyte to each cell until level is up to fill ring. Install filler caps.

IMPORTANT: Do not overfill battery. Electrolyte will overflow onto other parts of the machine and severe corrosion and deterioration will result.

REINSTALL BATTERY

1. Mount battery on battery support with terminal posts toward gas tank (Fig. 6).

2. Secure battery with clamp, support rod and wing nut (Fig. 6).

3. Install the (red) positive cable (rubber boot over end) to the positive (+) terminal and the negative cable (black) to the negative (-) terminals of the battery and secure with carriage bolts and wing nuts. Slide the rubber boot over the positive terminal to prevent possible short-out from occurring (Fig. 6).

CHECK CRANKCASE OIL

The Kohler engine is shipped with 3 pints of oil in the crankcase; however, level of oil must be checked before and after the engine is first started.

1. Position machine on a level surface and open the hood.

2. Remove dipstick and wipe it with a clean rag. Push dipstick down into dipstick tube and make sure it is seated fully. Pull dipstick out and check level of oil (Fig. 7). If oil level is low, add enough oil to raise level to FULL mark on dipstick.

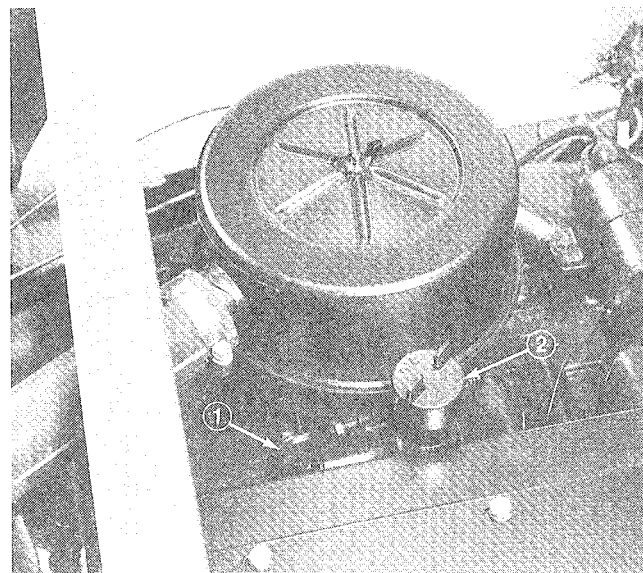

Figure 7

- 1. Dipstick
- 2. Filler cap

BEFORE OPERATING

3. Remove filler cap and pour oil into filler neck until level is at the FULL mark on dipstick. The Kohler engine uses any high-quality detergent oil having the American Petroleum Institute — API — “service classification” SF or SE. Oil viscosity — weight — must be selected according to anticipated ambient temperature. Temperature/viscosity recommendations are:

- A. Above +32°F (0°C) — Use SAE 30, and if it is not available, 10W-40 is an acceptable substitute.
- B. Below +32°F (0°C) — Use SAE 5W-20 or 5W-30, and if they are not available, 10W-30 is an acceptable substitute.

IMPORTANT: Check level of oil every 5 operating hours or daily. Initially, change oil after the first 5 hours of operation; thereafter, under normal conditions, change oil after every 25 hours of operation. However, change oil more frequently when engine is operated in extremely dusty or dirty conditions.

CHECK HYDRAULIC SYSTEM FLUID

The hydraulic system is designed to operate on SAE 10W-30 engine oil or, as a substitute, SAE 10W-40 engine oil. The machine's reservoir is filled at the factory with approximately 5 quarts of SAE 10W-30 engine oil. However, check level of transmission fluid before engine is first started and daily thereafter.

1. Position machine on a level surface, and stop the engine.
2. Remove dipstick cap (Fig. 8) from filler neck and wipe it with a clean rag. Insert dipstick cap

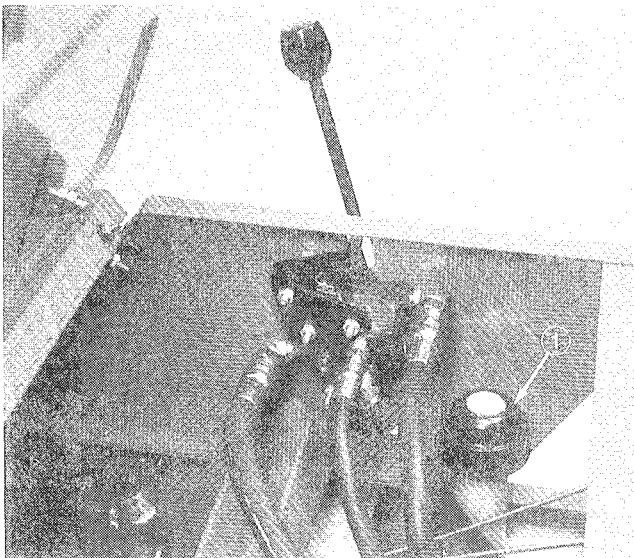

Figure 8

1. Dipstick cap

onto filler neck; then remove it and check level of fluid. If level is not within 1/2 inch from the full mark on dipstick, add SAE 10W-30 engine oil to raise level to full mark. Do not overfill.

3. Install dipstick filler cap onto filler neck.

4. Run engine for approximately 1 minute, recheck level of fluid and add oil as required.

FILL FUEL TANK WITH GASOLINE

THE TORO COMPANY STRONGLY RECOMMENDS THE USE OF FRESH CLEAN, UNLEADED REGULAR GRADE GASOLINE IN TORO GASOLINE POWERED PRODUCTS. UNLEADED GASOLINE BURNS CLEANER, EXTENDS ENGINE LIFE, AND PROMOTES GOOD STARTING BY REDUCING THE BUILD-UP OF COMBUSTION CHAMBER DEPOSITS. LEADED GASOLINE CAN BE USED IF UNLEADED IS NOT AVAILABLE.

Note: Do not mix oil with gasoline. Never use methanol, gasoline containing methanol, gasohol containing more than 10% ethanol, gasoline additives, premium gasoline, or white gas because engine fuel system damage could result.



DANGER

Because gasoline is flammable, caution must be used when storing or handling it. Do not fill fuel tank while engine is running, hot or when machine is in an enclosed area. Vapors may build up and be ignited by a spark or flame source many feet away. **DO NOT SMOKE** while filling the fuel tank to prevent the possibility of an explosion. Always fill fuel tank outside and wipe up any spilled gasoline before starting engine. Use a funnel or spout to prevent spilling gasoline before starting engine and fill tank to about 1 inch (25 mm) below the filler neck. Store gasoline in a clean safety-approved container and keep the cap in place on the container. Keep gasoline in a cool, well-ventilated place; never in an enclosed area such as a hot storage shed. To assure volatility, do not buy more than a 30 day supply of gasoline. Gasoline is a fuel for internal combustion engines; therefore, do not use it for any other purpose. Since many children like the smell of gas, keep it out of their reach because the fumes are explosive and dangerous to inhale.

BEFORE OPERATING

1. Remove cap from the fuel tank (Fig. 9) and fill the 5 gallon tank to within 1 inch from the top with unleaded gasoline. Install fuel tank cap tightly.

Note: Do not raise hood when filling fuel tank.

2. Wipe up gasoline that may have spilled to prevent a fire hazard.

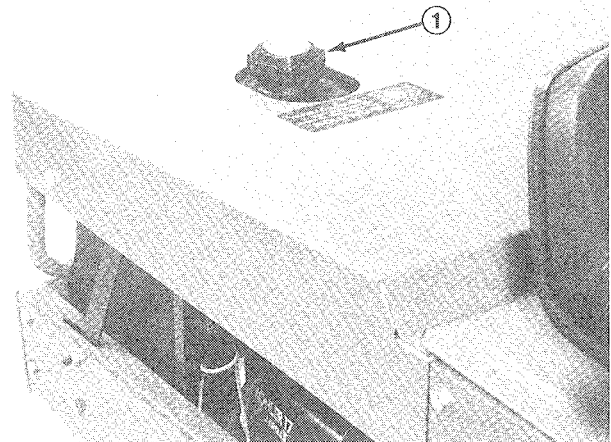

Figure 9

1. Fuel tank cap

CONTROLS

Parking Brake (Fig. 10) – Whenever the engine is shut off, the parking brake must be engaged to prevent accidental movement of the machine. To engage the parking brake, pull up on lever. Parking brake is equipped with an interlock, which shuts off engine when PTO switch or traction pedal are engaged with brake on.

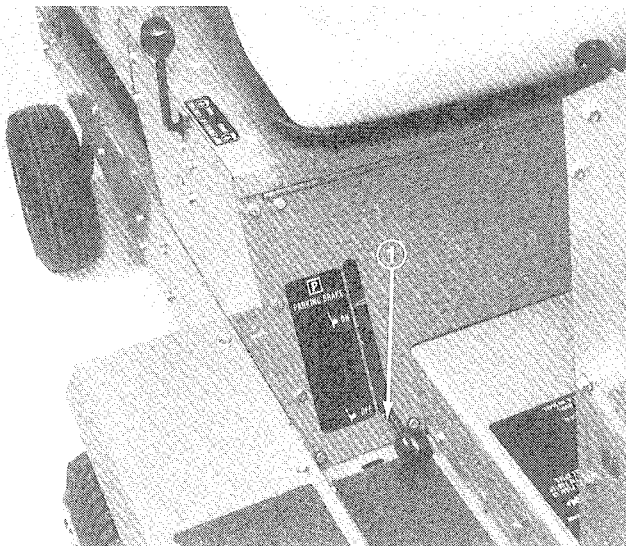

Figure 10

1. Parking brake

Traction Pedal (Fig. 11) – Traction pedal has two functions: one is to make the machine move forward, the other is to make it move rearward. Using the heel and toe of the right foot, depress top of pedal to move forward and bottom of pedal to move rearward. Ground speed is proportionate to how far pedal is depressed. For maximum ground

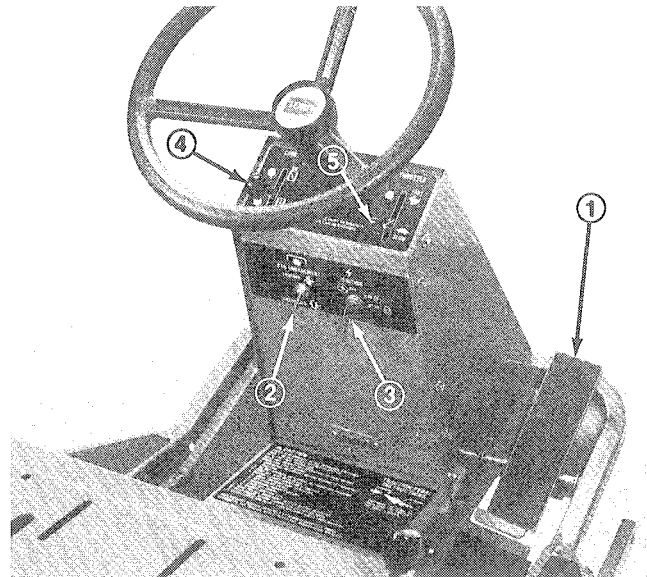

Figure 11

1. Traction pedal 4. Choke
2. PTO switch 5. Throttle
3. Ignition switch

speed with no load, traction pedal must be fully depressed while throttle is in FAST position. Maximum speed forward is 7 mph, 4 mph in reverse. To get maximum power under heavy load or when ascending a hill, have throttle in FAST position while depressing traction pedal slightly to keep engine rpm high. When engine rpm begins to decrease, release traction pedal slightly to allow rpm to increase.

PTO Switch (Fig. 11) – The PTO switch has two positions: ENGAGE and DISENGAGE. Toggle switch releases blade brake and engages electromagnetic clutch to drive deck pulleys.

CONTROLS

Ignition Switch (Fig. 11) — The ignition switch, which is used to start and stop the engine, has three positions: OFF, RUN and START. Rotate key clockwise — START position — to engage starter motor. Release key when engine starts. The key will move automatically to the ON position. To shut engine off, rotate key counterclockwise to the OFF position.

Choke (Fig. 11) — To start a cold engine, close carburetor choke by moving choke control forward to the ON position. After engine starts, regulate choke to keep engine running smoothly. As soon as possible, open the choke by pulling it rearward to the OFF position. A warm engine requires little or no choking.

Throttle (Fig. 11) — Throttle is used to operate engine at various speeds. Moving throttle forward increases engine speed — FAST; rearward decreases engine speed — SLOW. The throttle controls the speed of the cutter blades and, in conjunction with traction pedal, controls ground speed of the machine.

Implement Lift Lever (Fig. 12) The hydraulic lift lever has three positions: LOWER, RAISE, and NEUTRAL. To lower cutting unit to the ground, move lift lever forward. When lowering cutting unit, make sure hydraulic cylinder is completely extended before releasing lift lever. To raise cutting unit, pull lift lever rearward to the RAISE position.



CAUTION

Never raise cutting unit while blades are rotating because it is hazardous.

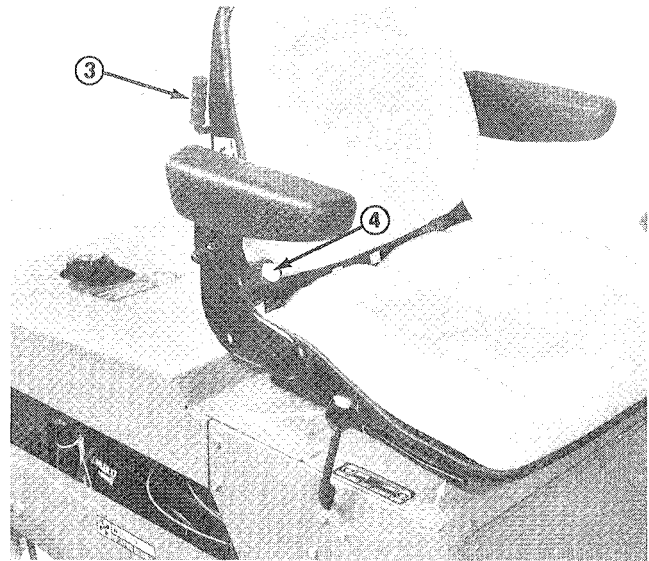

Figure 12

1. Implement lift lever
2. Fore and aft lever
3. Weight adjustment lever
4. Incline handle

Cutting unit must be raised when driving from one work area to another.

Deluxe Seat Adjustments (Fig. 12) — **Fore and Aft Adjustment** — Move lever on right side of seat outward, slide seat to desired position and release lever to lock seat into position.

Weight Adjustment — Push lever up or down to adjust to operator's weight. Lever up — light operator, lever in middle position — medium weight operator or lever down for heavy operator.

Inclining Backrest — Turn handle to adjust angle of backrest.

OPERATING INSTRUCTIONS

STARTING/STOPPING ENGINE

1. Be sure parking brake is set and PTO switch is in DISENGAGE position.
2. Remove foot from traction pedal and make sure pedal is in neutral position.
3. Cold Starting — Move choke lever to ON position and throttle lever to half throttle position.
4. Hot Starting — Move choke lever to OFF position and throttle lever to half throttle position.
5. Insert key into ignition switch and rotate it clockwise to start the engine. Release key when engine starts. Regulate the choke to keep engine running smoothly.

IMPORTANT: To prevent overheating of the starter motor, do not engage starter longer than 10 seconds. After 10 seconds of continuous cranking, wait 60 seconds before engaging starter motor again.

6. When engine is started for the first time, or after overhaul of the engine, transmission or axle, operate the machine in forward and reverse for one to two minutes. Also operate the lift lever and PTO switch to be sure of proper operation of all parts.

Turn steering wheel to the left and right to check steering response. Then shut engine off and check for oil leaks, loose parts and any other noticeable defects.



CAUTION

Shut engine off and wait for all moving parts to stop before checking for oil leaks, loose parts and other defects.

7. To stop the engine, move throttle control rearward to SLOW position, move PTO switch to DISENGAGE and rotate ignition key to OFF. Remove key from switch to prevent accidental starting.

CHECKING OPERATION OF INTERLOCK SWITCHES

The purpose of the safety interlock system is to prevent the engine from cranking or starting unless the operator is on the seat, the traction pedal is in neutral and the PTO switch is in the DISENGAGE position. In addition, the engine will stop if the operator gets off the seat or park brake

is on, when the PTO control is engaged or traction pedal is depressed.



CAUTION

Do not disconnect the safety switches because they are for the operator's protection. Check operation of the switches daily to be sure the interlock system is operating correctly. If a switch is defective, replace it before operating the machine. Replace the switches every two years to be sure of maximum safety.

1. Move PTO switch to disengage position and remove foot from traction pedal so it is fully released.
2. Rotate the ignition key to START. Engine should crank. If engine cranks, proceed to step 3. If engine does not crank, there may be a defect in the interlock system; correct defect.
3. Raise off the seat and engage the PTO switch while the engine is running. The engine should stop. If engine stops, the switch is operating correctly; thus, proceed to step 4. If engine does not stop, there is a defect in the interlock system; correct defect.
4. Raise off the seat and depress the traction pedal while engine is running and PTO lever is disengaged. The engine should stop. If engine stops the switch is operating correctly; thus, continue operation. If engine does not stop, there is a defect in the interlock system; correct defect.
5. Sit on seat, engage parking brake and depress traction pedal. Engine should stop.

OPERATING CHARACTERISTICS

Practice driving the PROLINE 118 before initial operation because it has a hydrostatic transmission and its characteristics are different than some turf maintenance machines. Some points to consider when operating the traction unit and cutting unit are the transmission, engine speed and load on the cutting blades.

To maintain enough power for the traction unit and cutting unit while mowing, regulate traction pedal to keep engine rpm high and somewhat constant. A good rule to follow is: decrease ground speed as the load on the cutting blades increases; and increase ground speed as load on the blades decreases. This allows the engine, working with the transmission, to sense the proper ground speed while maintaining high blade tip speed,

OPERATING INSTRUCTIONS

necessary for good quality-of-cut. Therefore, allow traction pedal to move upward as engine rpm decrease, and depress pedal slowly as rpm increase. By comparison, when driving from one work area to another — with no load and cutting unit raised — have throttle in FAST position and depress traction pedal slowly but fully to attain maximum ground speed.

Before stopping the engine, disengage all controls and move throttle to SLOW. Moving throttle to SLOW reduces high engine rpm, noise, vibration and the possibility of backfiring by the engine. Turn key to OFF to stop engine.

PUSHING TRACTION UNIT

In an emergency, the traction unit can be pushed for a very short distance. However, Toro does not recommend this as standard procedure.

IMPORTANT: Do not push or tow the traction unit faster than 2 to 3 mph because transmission may be damaged. If traction unit must be moved a considerable distance, transport it on a truck or trailer.

1. To push traction unit, traction pedal must be fully depressed forward to push forward or rearward to push in reverse.

LUBRICATION

GREASING BEARINGS AND BUSHINGS

The traction unit has grease fittings that must be lubricated regularly with No. 2 General Purpose Lithium Base Grease. If machine is operated under normal conditions, lubricate bearings and bushings after every 25 hours of operating. Bearings and bushings must be lubricated daily when operating conditions are extremely dusty and dirty. Dusty and dirty operating conditions could cause dirt to get into the bearings and bushings, resulting in accelerated wear.

The traction unit has bearings and bushings that must be lubricated and these lubrication points are: rear wheels (Fig. 13), rear wheel spindles (Fig. 14), steering pivot plate (Fig. 14), rear axle pivot bushings (Fig. 14), bellcrank assembly (Fig. 15), steering shaft bearing (Fig. 16) and front axle bearings (Fig. 15).

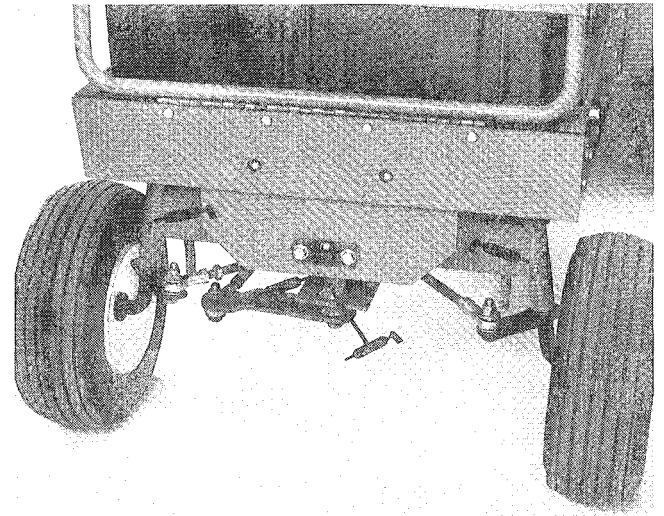

Figure 14

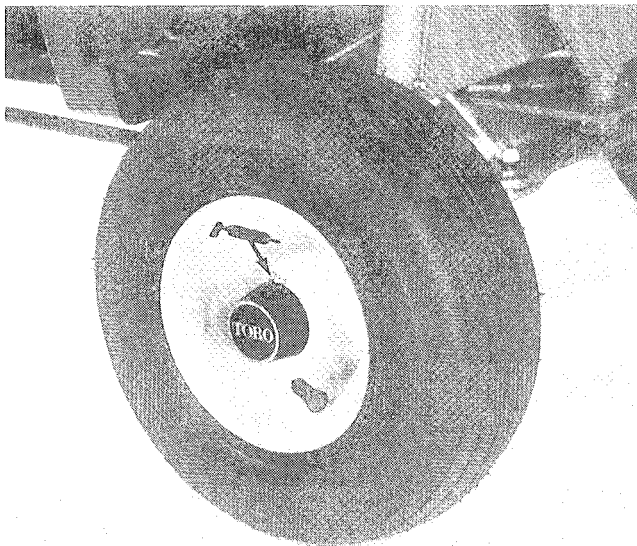

Figure 13

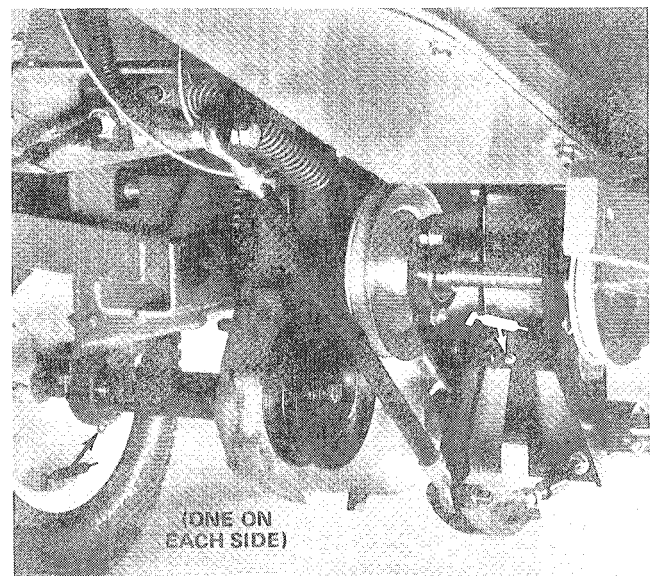

Figure 15

LUBRICATION

1. Wipe grease fitting clean so foreign matter cannot be forced into the bearing or bushing.
2. Pump grease into the bearing or bushing.
3. Wipe up excess grease.

Also lubricate the steering shaft, steering shaft pivot points (Fig. 16) and traction pedal bushings with a few drops of SAE 10 oil or a dry spray lube.

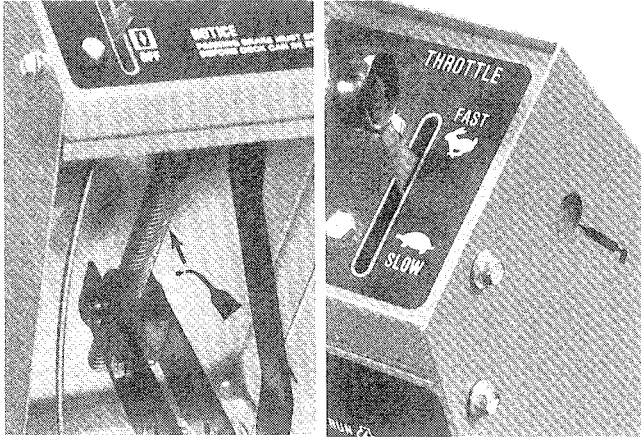

Figure 16

GREASE AXLES

The front wheels should be removed and axles greased, once a year, to prevent the formation of rust and to simplify future wheel removal.

CHANGE AXLE OIL

After every 500 hours of operation, oil in axle must be changed. If possible run machine just before changing oil. Warm oil flows more freely and carries more contaminants than cold oil.

1. Place a drain pan below drain plug on axle. Clean area around drain plug (Fig. 17).

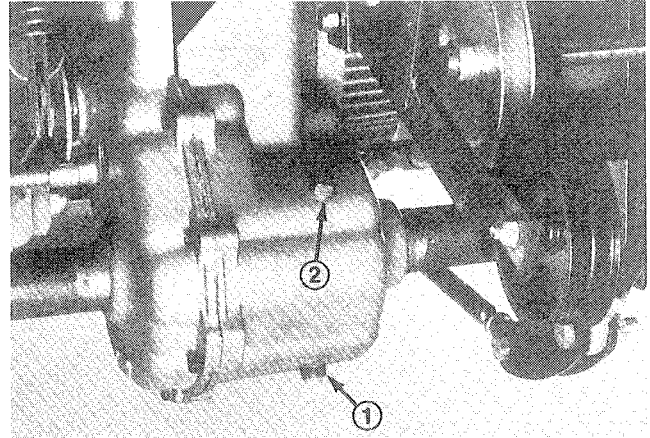

Figure 17

1. Drain plug
2. Fill plug

2. Remove drain plug and allow oil to flow into drain pan. After oil is drained, reinstall drain plug.

3. Remove axle fill plug and fill to plug level with SAE E.P. 90 wt. oil. (approximately 44 oz.).

MAINTENANCE

PARKING BRAKE ADJUSTMENT

If drive wheels do not rotate freely when brake lever is in the OFF position, or brake does not hold when lever is in the ON position, an adjustment is required.

1. Position brake lever in the OFF position.
2. Measure distance between disc brake actuating arm and stop pin on axle brake assembly. Distance should be less than .25" (Fig. 18).
3. If distance is greater than .25", tighten locknut to decrease distance between actuating arm and stop pin (Fig. 18).
4. Check clearance between brake pads and disc with a feeler gauge. Proper clearance is approximately .010" (Fig. 18).
5. The actuating arm should be more than .38" away from stop with brake lever in the ON position.
6. Check adjustment. Drive wheels should rotate freely when brake lever is in the OFF position.

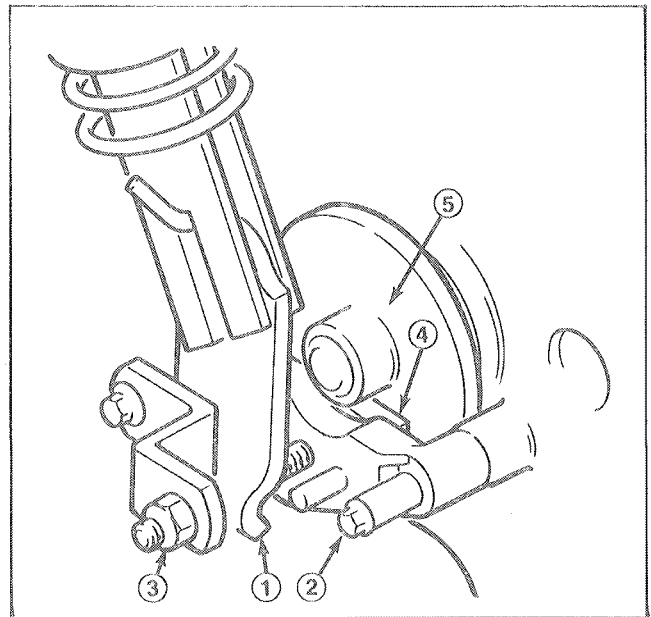

Figure 18

1. Brake actuating arm
2. Stop pin
3. Locknut
4. Brake pad (2)
5. Disc

MAINTENANCE

ADJUSTING STEERING

1. Turn steering wheel full to left to achieve a full left turn.
2. Check clearance between left tire and tie rod (Fig. 19). There should be $2.00 \pm .25$ clearance at this position.

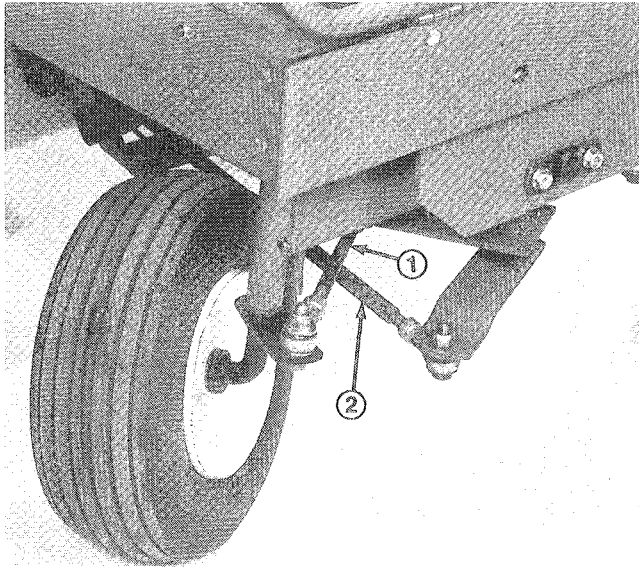

Figure 19

1. Tie rod 2. Steering rod

3. Adjust steering rods as required to gain clearance by loosening jam nuts and rotating rod. Retighten jam nuts after adjusting.
4. Repeat adjustment on right wheel.

CHANGING CRANKCASE OIL

For new or rebuilt engines, change oil after first 5 operating hours. Thereafter, under normal conditions, change oil after every 25 hours of engine operation. However, an engine operated in dusty or dirty conditions requires more frequent oil changes. If possible, run engine just before changing oil. Warm oil flows more freely and carries more contaminants than cold oil.

1. Place an oil drain pan below the drain plug on left side of crankcase. Clean area around drain plug (Fig. 20).
2. Remove drain plug and allow oil to flow into drain pan. After oil is drained, reinstall oil drain plug.
3. Remove filler cap and pour 3 pints of oil having the API "service classification" SF or SE into the filler neck. Oil viscosity — weight — is selected according to anticipated ambient temperature. Temperature/viscosity recommendations are:

- A. Above $+32^{\circ}\text{F}$ (0°C) — Use SAE 30, and if it is not available, 10W-40 is an acceptable substitute.
- B. Below 32°F (0°C) — Use SAE 5W-20 or 5W-30, and if they are not available, 10W-30 is an acceptable substitute.

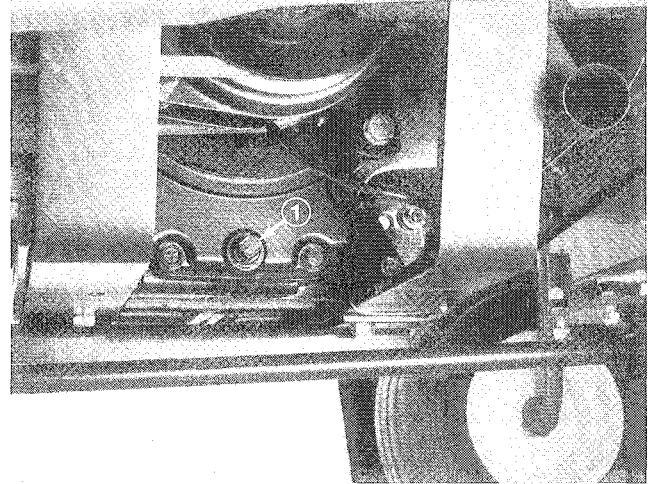

Figure 20

1. Drain plug

4. Check oil and make sure level is up to the FULL mark on dipstick. Add more oil if level is low; however, DO NOT OVERFILL.

SERVICING AIR CLEANER

The foam pre-cleaner must be cleaned and re-oiled after every 25 hours engine operation if engine is operated in clean air conditions. However, air cleaner must be cleaned every few hours if operating conditions are extremely dusty or sandy.

1. Remove wing nut and cover (Fig. 21).

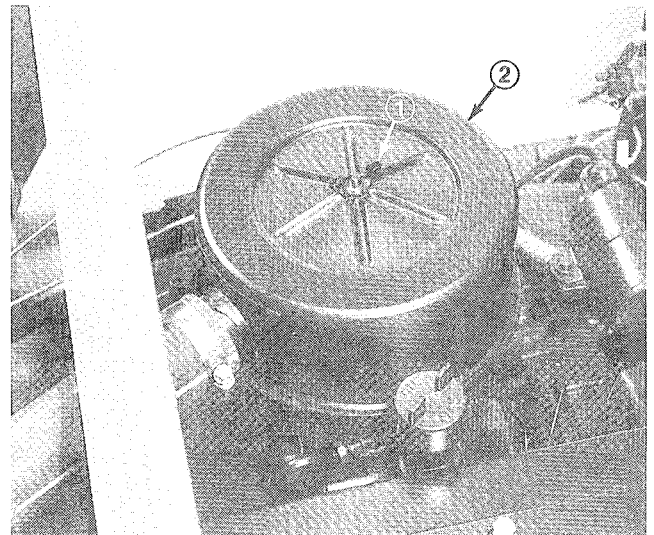

Figure 21

1. Wing nut 2. Cover

MAINTENANCE

2. Remove foam pre-cleaner by sliding it off the paper element (Fig. 22).

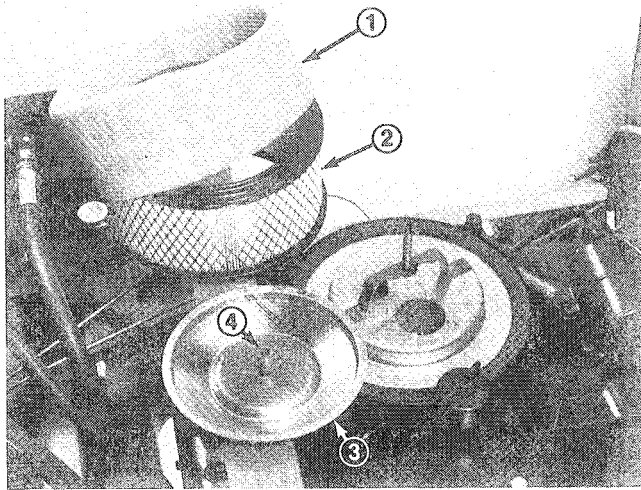

Figure 22

1. Foam pre-cleaner
2. Paper element
3. Element cover
4. Seal

3. a. Wash foam pre-cleaner in detergent and warm water.
b. Wrap foam pre-cleaner in cloth and squeeze dry. Do not wring pre-cleaner.
c. Saturate foam pre-cleaner in engine oil. Squeeze to remove excess oil.
4. Reinstall on paper cartridge.

Inspect paper element every 50 hours of operation and replace when dirty or damaged. Do not wash paper element or do not clean with compressed air as damage will occur.

Note: With air cleaner disassembled, check air cleaner components for damage. Replace if necessary. Make sure rubber tube in base plate is securely in place or severe engine damage may occur.

5. Reinstall element with pre-cleaner, air cleaner element cover, element cover seal, air cleaner cover and wing nut (Fig. 22).

6. Tighten wing nut 1/2 to 1 turn after nut contacts cover. Do not overtighten.

CLEANING CYLINDER HEAD FINS

To avoid overheating and possible engine damage, clean cooling fins on cylinder head every day if necessary.

1. Open the hood. Pull high tension wires off spark plugs.

2. Clean dirt, grass and chaff from outside of cylinder, cylinder head fins and air intake screen.

3. Push high tension wire onto spark plug and close the hood.

ADJUSTING CARBURETOR

Lack of power accompanied by black sooty exhaust smoke is usually caused by a rich carburetor setting. Since a dirty air cleaner element causes the same conditions, check it before adjusting carburetor.

IMPORTANT: Check fuel filter and make sure the choke is operating correctly before the carburetor is adjusted.

1. Idle fuel adjusting screw (Fig. 23) — Close screw by gently rotating it clockwise. Open screw by rotating it 1 - 1-1/4 turns counterclockwise.

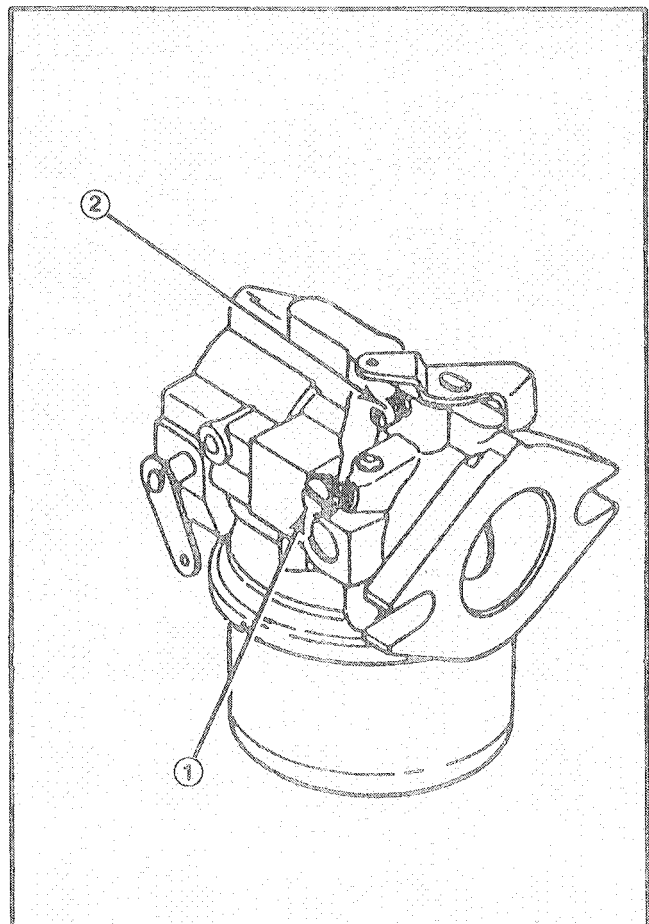

Figure 23

1. Idle fuel adjusting screw
2. Idle speed setting screw

MAINTENANCE

IMPORTANT: Do not close the screw too tightly because the screw will likely be damaged.

Note: This setting is approximate; however, the setting will allow engine to be started so carburetor can be fine tuned — steps 9.



WARNING

Engine must be running so final adjustment of the carburetor can be performed. To guard against possible personal injury, keep hands, feet, face and other parts of the body away from the muffler, other hot parts of the engine, and other moving or rotating parts of the engine. Assure PTO switch is in DISENGAGE position and cutting unit is on the shop floor. Also engage parking brake.

2. Start engine and let it run for 5-10 minutes at half throttle to warm up. After warm up, move throttle to slow and turn idle fuel adjusting screw clockwise until speed decreases and note position of screw. Now turn screw counterclockwise — the engine speed may first increase, then it will decrease as screw is turned. Note the position of screw when engine speed starts to decrease. Set the screw at the midpoint of the two positions noted.

3. Idle Speed Setting (Fig. 23) — Run engine at half-throttle to SLOW and set engine speed to 1750 RPM by turning the idle speed adjusting screw clockwise or counterclockwise.

ADJUSTING THROTTLE CONTROL

1. Loosen cable clamp screw securing cable to engine.
2. Position throttle control lever forward approximately .06" from top of slot in steering tower.
3. Pull firmly on throttle cable till governor arm contacts stop.
4. Tighten cable clamp screw and check engine RPM setting.

3200 ± 100 — High Idle
1750 ± 50 — Low Idle

ADJUSTING CHOKE CONTROL

1. Loosen cable clamp screw securing cable to engine.
2. Place choke control in ON position.
3. Pull firmly on choke cable and tighten cable clamp screw.

REPLACING FUEL FILTER

An in-line filter is incorporated into the fuel line. Use the following procedures should replacement become necessary:

1. Clamp both fuel lines that connect to the fuel filter so gasoline cannot drain when lines are removed.



CAUTION

Since gasoline is highly flammable, drain it outdoors and make sure engine is cool to prevent a potential fire hazard. Wipe up any gasoline that may have spilled. Do not drain gasoline near any open flame or where gasoline fumes may be ignited by a spark. Do not smoke a cigar, cigarette, or a pipe when handling gasoline.

2. Loosen the hose clamps at both ends of the filter and pull fuel lines off filter.
3. Slide hose clamps onto ends of fuel lines. Push fuel lines onto fuel filter and secure them with hose clamps. Be sure arrow on side of filter points toward the fuel pump.

CHECKING AND REPLACING SPARK PLUGS

Since air gap between center and side electrodes increases gradually during normal engine operation, check condition of electrodes at 100 hour intervals. The correct spark plugs to use in the engine are Champion RV-15YC or equivalent. Set air gap at .025 in.

1. Clean area around spark plugs so dirt does not fall into cylinders when plugs are removed.
2. Pull high tension wires off spark plugs and remove plugs from cylinder head.

MAINTENANCE

3. Check condition of center and side electrodes to determine operating temperature of engine.

- A. Light brown insulator tip indicates correct spark plug and heat range.
- B. Black or oily insulator tip indicates an excessively rich fuel mixture, possibly caused by a dirty air cleaner element or a carburetor that is set too rich.
- C. Light gray or blistered-white insulator indicates overheating caused by a lean carburetor setting or incorrect spark plug (heat range too high).

IMPORTANT: A cracked, fouled or dirty spark plug must be replaced. Do not sandblast, scrape or clean electrodes by using a wire brush because grit may release from the plug and enter combustion chamber resulting in engine damage.

4. After setting air gap at .025", install spark plug in cylinder head. Tighten the plug to 10-15 ft-lb. Push high tension wire onto spark plug.

Note: Keep terminals and top of battery clean. Wash battery with baking soda and rinse with clear water. Do not let soda solution enter battery cells because electrolyte solution will be neutralized.



CAUTION

Hydrogen gas is produced while battery is being charged and inhaling the fumes may cause nausea. Since fumes are explosive, keep open flame, electrical spark, cigars and cigarettes away from the battery to prevent an explosion.

WIRING HARNESS SERVICE

Prevent corrosion of wiring terminals by applying Grafo 112X (Skin-over) grease, Toro Part No. 505-47, to the inside of all harness connectors whenever the harness is replaced.

Always disconnect battery cables, ground cable (—) first, to prevent possible wiring damage from short-outs whenever working with the electrical system.

SERVICING BATTERY

IMPORTANT: Before welding on the machine, disconnect battery ground cable from engine. This prevents damage to the electrical system.

Once a week, check electrolyte solution in battery to make sure level is above the plates. If level is low, add distilled water to the affected cells. The electrolyte solution consists of sulfuric acid and distilled water. The "charge state" of the battery affects specific gravity — weight — of electrolyte solution. As the battery discharges, sulfuric acid is chemically withdrawn from electrolyte solution, resulting in lead sulfate build-up on the plates. This causes a decrease in specific gravity of electrolyte. A fully charged battery has an electrolyte solution of 1.260 to 1.280 specific gravity. By contrast, battery with a solution of less than 1.240 is in a discharged condition; therefore, charging is required.

ADJUSTING TRANSMISSION FOR NEUTRAL

The machine must not creep when traction pedal is released. If it does creep, an adjustment is required.

1. Park machine on a level surface and shut engine off. Disengage PTO switch and position parking brake in OFF.
2. Jack up front of machine until front tires are off shop floor. Support machine with jack stands to prevent it from falling accidentally.
3. Loosen two capscrews securing traction plate so plate is free to move (Fig. 24).

MAINTENANCE

4. Start engine and rotate traction plate (Fig. 24) in either direction until wheel ceases rotation.

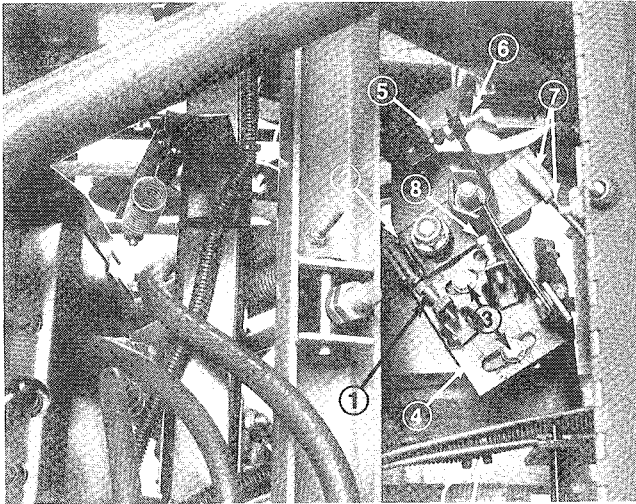

Figure 24

- | | |
|--------------------|----------------------------------|
| 1. Rear stop screw | 5. Neutral switch |
| 2. Traction lever | 6. Adjusting screw |
| 3. Capscrews (2) | 7. Traction cable and ball joint |
| 4. Traction plate | 8. Front stop screw |

5. Stop engine and tighten capscrews to secure traction plate (Fig. 24).

6. To adjust neutral switch, loosen jam nut on adjusting screw. Turn screw toward switch until circuit through switch is made; then turn screw an additional 1/2 turn. Tighten jam nut.

7. Start engine and check adjustment. Repeat adjustment, if necessary.

8. Adjust traction cable or ball joints (Fig. 24) as required to attain a $4.00'' \pm .25''$ dimension from tip of traction pedal to footrest, when pedal is in neutral position.

9. Loosen jam nut on rear stop screw and thread screw into bracket (Fig. 24).

10. Depress front of traction pedal, rotating traction lever (Fig. 24) counterclockwise, until lever stops. While holding pedal down, back out stop screw until it contacts traction lever, then back out screw two additional turns. Tighten jam nut.

11. Loosen jam nut on front stop screw and thread screw into bracket (Fig. 24).

12. Depress rear of traction pedal, rotating traction lever (Fig. 24) clockwise, until lever stops. While holding pedal down, back out stop screw until it contacts traction lever, then back it out two additional turns. Tighten jam nut.

13. Start engine and check adjustment. Repeat adjustment, if necessary.

14. Stop the engine. Remove jack stands and lower machine to the shop floor. Test drive the machine to be sure it does not creep.

CHANGING HYDRAULIC OIL FILTER

The hydraulic oil filter keeps the hydraulic system relatively free of contaminants. However, the hydraulic oil filter must be serviced at regular intervals. The intervals are: initially, after the first five hours of operation, and thereafter, every 250 hours of operation or yearly, whichever comes first. Use a genuine TORO oil filter for replacement.

1. Remove hydraulic oil filter from mounting head (Fig. 25). Use bottom type filter wrench. Dispose of the filter properly.

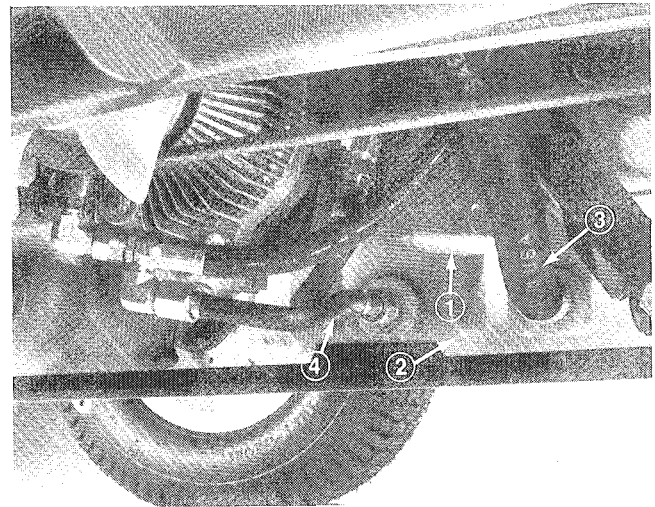

Figure 25

- | | |
|--------------|------------------|
| 1. Filter | 3. Hose assembly |
| 2. Reservoir | 4. Tube assembly |

2. Apply a film of oil on the gasket. Install filter by hand until gasket contacts mounting head; then tighten filter an additional three-fourths turn.

3. Start engine and check for oil leaks. Allow engine to run for about two minutes so any air in the system is purged. Then shut engine off.

4. Check level of hydraulic oil in reservoir; refer to Check Hydraulic System Fluid, page 11.

CHANGING HYDRAULIC SYSTEM OIL

The hydraulic system oil must be changed after every 250 hours of operation or yearly, whichever comes first. The reservoir for the hydraulic oil has a capacity of approximately 5 U.S. quarts.

1. Park the machine on a level surface, lower the cutting unit to the shop floor, set the parking brake, and turn the engine off.

MAINTENANCE

2. Clean the area around the hydraulic oil filter and remove the filter from the bottom of the filter housing (Fig. 25). Use bottom type filter wrench.

3. Disconnect tube assembly and hose assembly from reservoir and allow the oil to flow into a drain pan (Fig. 25).

Note: To drain oil remaining in system, disconnect spark plug wires and crank engine for 15 seconds. This will pump remaining oil out of system thru tube assembly. Do not crank engine for more than 15 seconds.

4. Install the new hydraulic oil filter onto the bottom of the filter housing.

5. Install the tube assembly and hose assembly to reservoir.

6. Fill the reservoir to the proper level; refer to "Checking Hydraulic System Fluid, page 11.

7. Place all controls in neutral or disengaged position and start engine. Run engine at lowest possible RPM to purge the system of air.

8. Run engine until lift cylinder extends and retracts and forward and reverse wheel motion is achieved.

9. Stop the engine and check the oil level in reservoir, add oil if necessary.

10. Check all connections for leaks.

3. Loosen jam nuts and adjust, if necessary, to attain needed clearance.

4. Start engine and raise lift arms (cutting unit) until lift cylinder is fully retracted and lift arms (cutting unit) is fully raised.

5. Check distance between clevis pin and bottom of loops on springs. Distance should be .25" or less (Fig. 26 & 27).

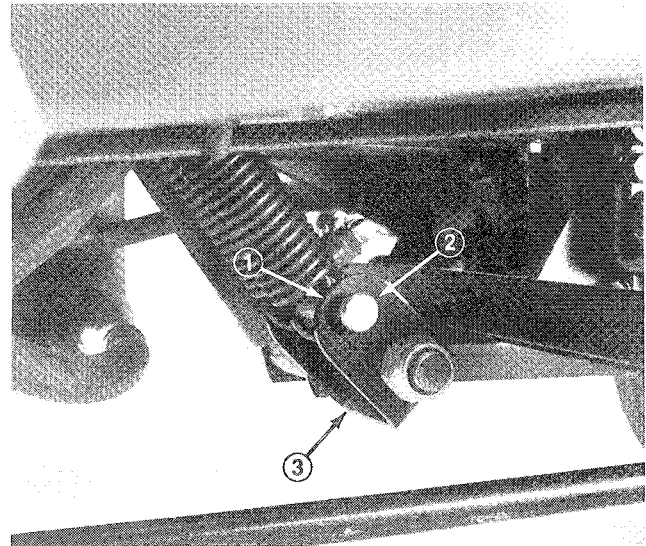

Figure 27

1. .25" dimension here
2. Cotter pin & clevis pin
3. Lift bracket

ADJUSTING LIFT CYLINDER AND COUNTERBALANCE SPRINGS

1. Start engine and lower lift arms (cutting unit) until lift cylinder is fully extended and lift arms (cutting unit) is fully lowered.

2. Measure distance between cylinder jam nuts and cylinder pivot pin (Fig. 26). Distance should be approximately 2-1/4".

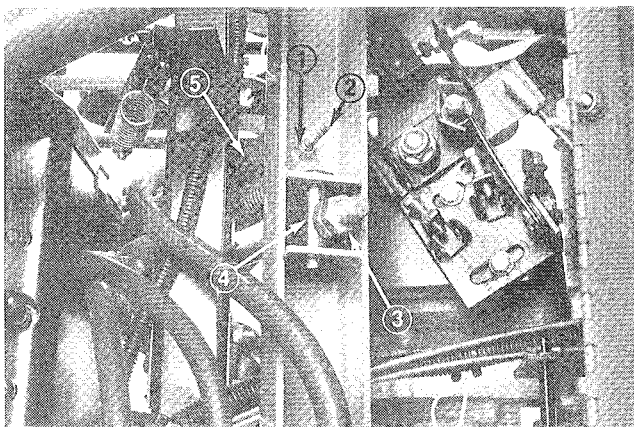

Figure 26

1. Adjusting nut
2. Lift arm "T" hook
3. Jam nuts
4. Cylinder pivot pin
5. Counterbalance springs

6. Adjust nut on lift arm "T" hook to obtain required distance (Fig. 26).

Note: Whenever cutting deck is removed from carrier frame, counter balance springs must be disconnected as follows:

- A. Start engine and raise lift arms (cutting unit) until lift cylinder is fully retracted and lift arms (cutting unit) is fully raised.
- B. Remove cotter pin and clevis pin securing bottom of springs to lift bracket (Fig. 27).
- C. Lift arms may now be lowered and deck removed without carrier frame raising due to spring tension.

ADJUSTING OR REPLACING BELTS

If belt slippage occurs, idler pulleys must be adjusted to increase belt tension.

1. Stop engine and raise hood.

2. Measure distance from bottom of spacer on pulley mounting screw to bottom of slot in idler adjustment link (Fig. 28). Distance should be .25" or less.

MAINTENANCE

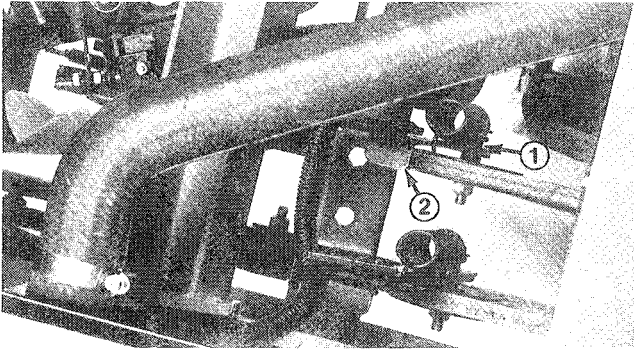

Figure 28

1. Spacer 2. Idler adjustments

3. To adjust, remove cotter pin and washer securing idler adjustment link to spring anchor. Slide link off mounting pin and up until bottom of spacer is within .25" from bottom of slot.

4. Reposition link onto spring anchor and secure with washer and cotter pin.

To replace traction or jackshaft belt, use the following procedures and belt routing diagram (Fig. 29).

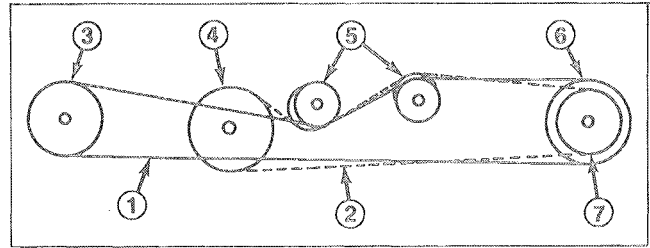

Figure 29

1. Jackshaft belt
2. Traction belt
3. Jackshaft pulley
4. Transmission pulley
5. Idler pulleys
6. Clutch pulley
7. Engine pulley

1. Clutch anchor bolt must be removed, and clutch unplugged from wire harness before traction belts can be removed.

2. Release tension in idler pulleys before removing or installing belts.

3. When installing traction belt, route belt over transmission fan before installing on engine pulley.

HYDRAULIC SCHEMATIC

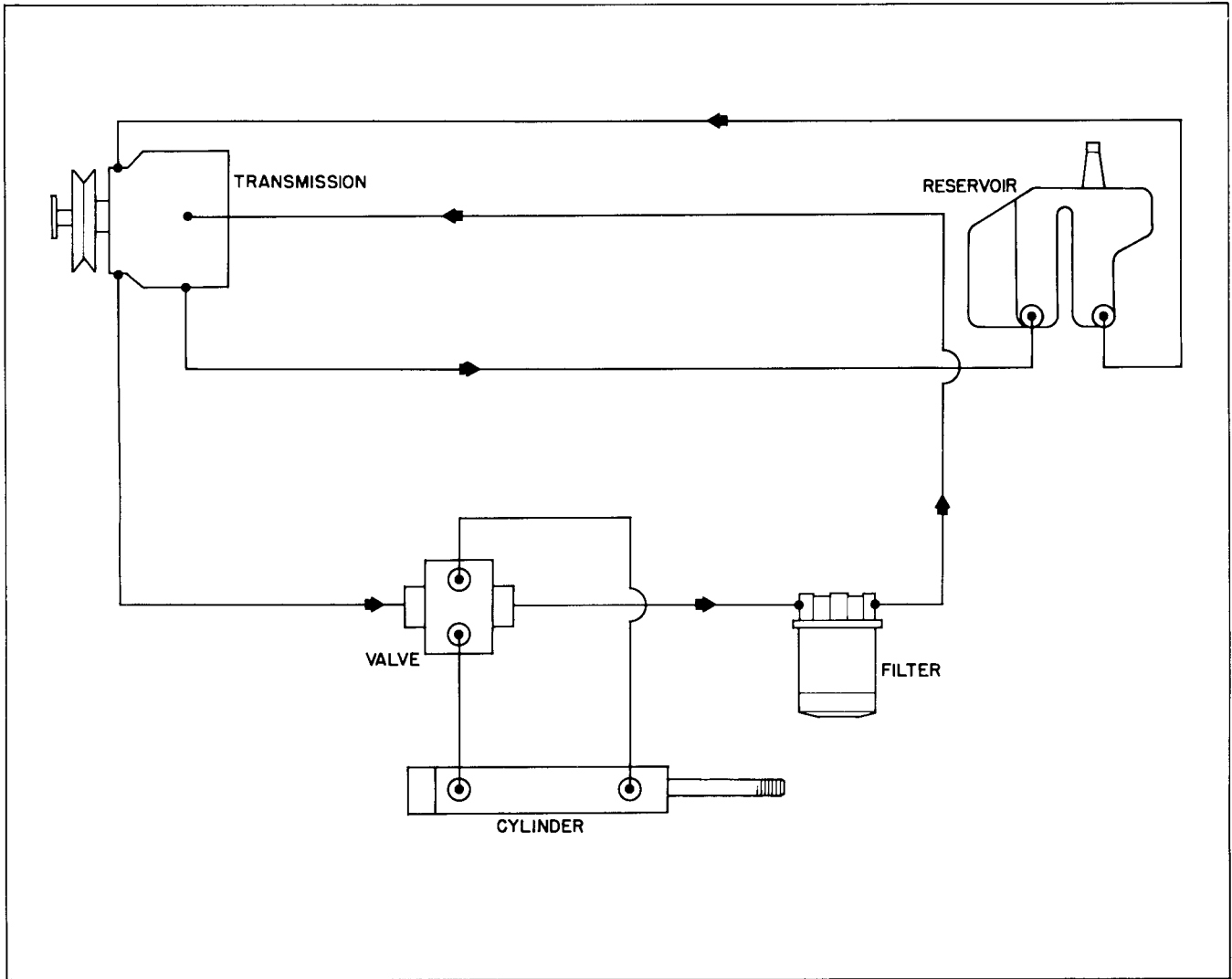

ELECTRICAL SCHEMATIC

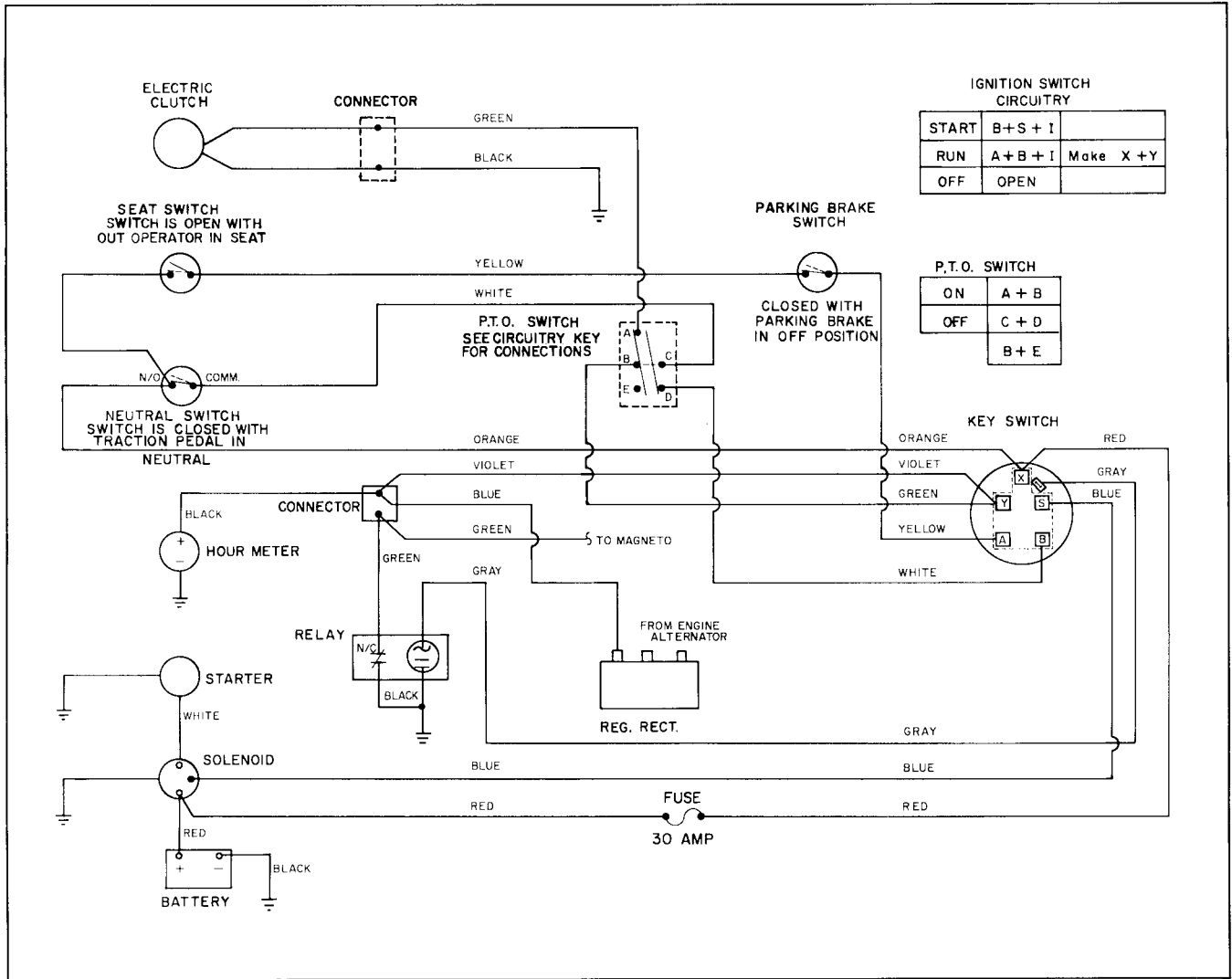

PREPARATION FOR SEASONAL STORAGE

Traction Unit

1. Thoroughly clean the traction unit, cutting unit and the engine, paying special attention to these areas:
 - underneath the cutting unit
 - under the cutting unit belt covers
 - P.T.O. traction and cutting unit belts
 - all grease fittings and pivot points
2. Check the tire pressure. Inflate all traction unit tires to 10 to 15 psi.
3. Remove, sharpen and balance the cutting unit's blades.
4. Check all fasteners for looseness; tighten as necessary.
5. Grease or oil all grease fittings, steering shaft and pivot points. Wipe off any excess lubricant.
6. Lightly sand and use touch up paint on painted areas that are scratched, chipped or rusted. Repair any dents in the metal body.
7. Service the battery and cables as follows:
 - a. Remove the battery terminals from the battery posts.
 - b. Clean the battery, terminals and posts with a wire brush and baking soda solution.
 - c. Coat the cable terminals and battery posts with Grafo 112X skin-over grease (Toro Part Number 505-47), or petroleum jelly to prevent corrosion.

- d. Slowly recharge the battery every 60 days for 24 hours to prevent lead sulfation of the battery.

Engine

1. Drain the engine oil from the oil pan and replace the drain plug.
2. Refill the engine with 3 pints of recommended motor oil. Refer to Changing Crankcase Oil.
3. Start the engine and run at idle speed for two minutes.
4. Drain the gasoline from the fuel tank carburetor, and fuel lines or run until empty. Reinstall all lines and secure all connections.
5. Stop the engine; remove spark plugs.
6. Pour one tablespoon of clean engine oil into each spark plug hole.
7. Reinstall the spark plug, but do not connect plug wires.
8. Crank the engine with the starter for 2 to 3 revolutions to distribute the oil in the cylinders.
9. Thoroughly clean and service the air cleaner assembly.
10. Seal the air cleaner inlet and the exhaust outlet with weatherproof masking tape.
11. Check the oil filler cap and gas cap to ensure they are all securely in place.

PRODUCT IDENTIFICATION

The traction unit has two identification numbers: a model number and a serial number that are stamped into a plate. The traction unit identification plate is located on back side of steering tower. In any correspondence concerning the traction unit, supply the model and serial numbers to ensure correct information and replacement parts are obtained.

To order replacement parts from an Authorized TORO ProLine Service Dealer supply the following information:

1. Model and serial numbers of the traction unit.
2. Part number, description and quantity of parts desired.

Note: Do not order by reference number if a parts catalog is being used; use the part number.

The Toro Promise

A ONE YEAR LIMITED WARRANTY

The Toro Company promises to repair your TORO Product if defective in materials or workmanship. The following time periods from the date of purchase apply:

Commercial Products 1 Year

The cost of parts and labor are included, but the customer pays the transportation costs on walk rotary mowers with cutting unit widths of less than 25".

If you feel your TORO product is defective and wish to rely on The Toro Promise, the following procedure is recommended:

1. Contact your Authorized TORO ProLine Service Dealer (the Yellow Pages of your telephone directory is a good reference source).
2. The TORO ProLine Service Dealer will advise you on the arrangements that can be made to inspect and repair your product.
3. The TORO ProLine Service Dealer will inspect the product and advise you whether the product is defective and, if so, make all repairs necessary to correct the defect without an extra charge to you.

If for any reason you are dissatisfied with the distributor's analysis of the defect or the service performed, you may contact us.

Write:

TORO Consumer Products Service Department
8111 Lyndale Avenue South
Minneapolis, Minnesota 55420

The above remedy of product defects through repair by an Authorized TORO ProLine Service Dealer is the purchaser's sole remedy for any defect.

THERE IS NO OTHER EXPRESS WARRANTY. ALL IMPLIED WARRANTIES OF MERCHANTABILITY AND FITNESS FOR USE ARE LIMITED TO THE DURATION OF THE EXPRESS WARRANTY.

Some states do not allow limitations on how long an implied warranty lasts, so the above limitation may not apply to you.

This Warranty applies only to parts or components which are defective and does not cover repairs necessary due to normal wear, misuse, accidents, or lack of proper maintenance. Regular, routine maintenance of the unit to keep it in proper condition is the responsibility of the owner.

All warranty repairs reimbursable under the Toro Promise must be performed by an Authorized TORO ProLine Service Dealer using Toro approved replacement parts.

Repairs or attempted repairs by anyone other than an Authorized TORO ProLine Service Dealer are not reimbursable under the Toro Promise. In addition, these unauthorized repair attempts may result in additional malfunctions, the correction of which is not covered by warranty.

THE TORO COMPANY IS NOT LIABLE FOR INDIRECT, INCIDENTAL OR CONSEQUENTIAL DAMAGES IN CONNECTION WITH THE USE OF THE PRODUCT INCLUDING ANY COST OR EXPENSE OF PROVIDING SUBSTITUTE EQUIPMENT OR SERVICE DURING PERIODS OF MALFUNCTION OR NON-USE.

Some states do not allow the exclusion or limitation of incidental or consequential damages, so the above limitation or exclusion may not apply to you.

This warranty gives you specific legal rights, and you may also have other rights which vary from state to state.

COUNTRIES OTHER THAN THE UNITED STATES OR CANADA

Customers who have purchased TORO products exported from the United States or Canada should contact their TORO Distributor (Dealer) to obtain guarantee policies for your country, province or state. If for any reason

you are dissatisfied with your Distributor's service or have difficulty obtaining guarantee information, contact the TORO importer. If all other remedies fail, you may contact us at The Toro Company.