



Count on it.

Operator's Manual

DH 140 Lawn Tractor

Model No. 74560—Serial No. 314000151 and Up

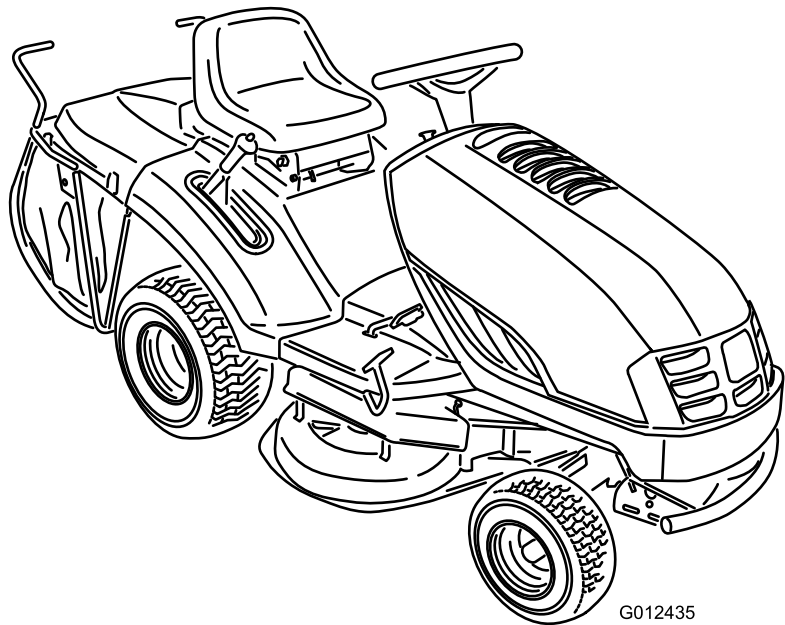

G012435



This product complies with all relevant European directives. For details, see the separate product specific Declaration of Conformity (DOC) sheet.



Figure 2

1. Safety alert symbol

Introduction

This rotary-blade, riding lawn mower is intended to be used by residential homeowners. It is designed primarily for cutting grass on well-maintained lawns on residential properties. It is not designed for cutting brush or for agricultural uses.

Read this information carefully to learn how to operate and maintain your product properly and to avoid injury and product damage. You are responsible for operating the product properly and safely.

You may contact Toro directly at www.Toro.com for product and accessory information, help finding a dealer, or to register your product.

Whenever you need service, genuine Toro parts, or additional information, contact an Authorized Service Dealer or Toro Customer Service and have the model and serial numbers of your product ready. Figure 1 identifies the location of the model and serial numbers on the product. Write the numbers in the space provided.

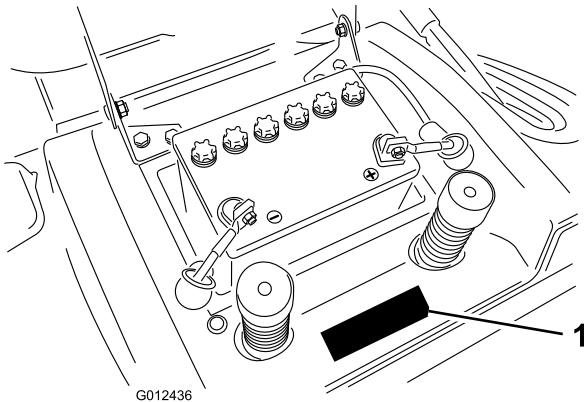

Figure 1

1. Model and serial number location (under the seat)

Model No. _____
Serial No. _____

This manual identifies potential hazards and has safety messages identified by the safety alert symbol (Figure 2), which signals a hazard that may cause serious injury or death if you do not follow the recommended precautions.

Contents

Introduction	2	Servicing the Blades	28
Safety	4	Removing the Mower	29
Safe Operation Practices for Riding Rotary Lawn Mowers	4	Installing the Mower	29
Toro Riding Mower Safety	5	Adjusting the Front-to-Rear Blade Slope	29
Sound Pressure	6	Leveling the Mower from Side-to-Side	30
Sound Power	6	Checking and Setting the Cutting Height	31
Hand-Arm Vibration	6	Installing the Adjustable Links	32
Whole Body Vibration	6	Storage	33
Slope Indicator	7	Troubleshooting	34
Safety and Instructional Decals	8	Schematics	36
Product Overview	9		
Controls	9		
Specifications	9		
Operation	10		
Filling the Fuel Tank	10		
Checking the Engine Oil Level	10		
Using the Parking Brake	10		
Positioning the Seat	10		
Using the Blade Control (PTO)	11		
Setting the Height of Cut	11		
Starting the Engine	11		
Stopping the Engine	12		
Using the Safety Interlock System	13		
Testing the Safety Interlock System	14		
Pushing the Machine Manually	14		
Driving the Machine Forward or Backward	14		
Stopping the Machine	15		
Emptying the Grass Collector	15		
Mulching the Grass	16		
Optional Towing Hitch	16		
Operating Tips	17		
Maintenance	18		
Recommended Maintenance Schedule(s)	18		
Lubrication	18		
Greasing and Lubricating the Machine	18		
How to Grease the Machine	18		
Where to Add Grease	20		
Engine Maintenance	20		
Servicing the Air Cleaner	20		
Servicing the Engine Oil	21		
Servicing the Spark Plug	22		
Fuel System Maintenance	23		
Draining the Fuel Tank	23		
Replacing the Fuel Filter	24		
Electrical System Maintenance	24		
Replacing the Fuses	24		
Servicing the Battery	24		
Drive System Maintenance	26		
Checking the Tire Pressure	26		
Servicing the Brake	26		
Servicing the Grass Collector	27		
Removing the Grass Collector	27		
Installing the Grass Collector	27		
Cleaning the Grass Collector and Tunnel	28		
Mower Deck Maintenance	28		

Safety

Safe Operation Practices for Riding Rotary Lawn Mowers

Read and understand the contents of this manual before operating the machine.

The safety alert symbol (Figure 2) is used to alert you to potential personal injury hazards. Obey all safety messages that follow this symbol to avoid possible injury or death.

The following instructions are from the CEN standard EN 836:1997.

This product is capable of amputating hands and feet and of throwing objects. Always follow all safety instructions to avoid serious injury or death.

Training

- Read the instructions carefully. Be familiar with the controls and the proper use of the equipment.
- Never allow children or people unfamiliar with these instructions to use the lawn mower. Local regulations can restrict the age of the operator.
- Never mow while people, especially children, or pets are nearby.
- Keep in mind that the operator or user is responsible for accidents or hazards occurring to other people or their property.
- Do not carry passengers.
- All drivers should seek and obtain professional and practical instruction. Such instruction should emphasize:
 - the need for care and concentration when working with ride-on machines;
 - control of a ride-on machine sliding on a slope will not be regained by the application of the brake. The main reasons for loss of control are:
 - ◇ insufficient wheel grip;
 - ◇ being driven too fast;
 - ◇ inadequate braking;
 - ◇ the type of machine is unsuitable for its task;
 - ◇ lack of awareness of the effect of ground conditions, especially slopes;
 - ◇ incorrect hitching and load distribution.

Preparation

- While mowing, always wear substantial footwear and long trousers. Do not operate the equipment when barefoot or wearing open sandals.
- Thoroughly inspect the area where the equipment is to be used and remove all objects which may be thrown by the machine.
- **Warning**—Fuel is highly flammable.

- Store fuel in containers specifically designed for this purpose.
- Refuel outdoors only and do not smoke while refuelling.
- Add fuel before starting the engine. Never remove the cap of the fuel tank or add fuel while the engine is running or when the engine is hot.
- If fuel is spilled, do not attempt to start the engine but move the machine away from the area of spillage and avoid creating any source of ignition until fuel vapors have dissipated.
- Replace all fuel tanks and container caps securely.
- Replace faulty silencers.
- Before using, always visually inspect to see that the blades, blade bolts and cutter assembly are not worn or damaged. Replace worn or damaged blades and bolts in sets to preserve balance.
- On multi-bladed machines, take care as rotating one blade can cause other blades to rotate.

Operation

- Do not operate the engine in a confined space where dangerous carbon monoxide fumes can collect.
- Mow only in daylight or in good artificial light.
- Before attempting to start the engine, disengage all blade attachment clutches and shift into neutral.
- Do not use on slopes of more than
 - 10° when mowing on side hills;
 - 15° when mowing uphill or downhill.
- Remember there is no such thing as a safe slope. Travel on grass slopes requires particular care. To guard against overturning:
 - do not stop or start suddenly when going up or downhill;
 - machine speeds should be kept low on slopes and during tight turns;
 - stay alert for humps and hollows and other hidden hazards;
 - never mow across the face of the slope, unless the lawn mower is designed for this purpose.
- Use care when pulling loads or using heavy equipment.
 - Use only approved drawbar hitch points.
 - Limit loads to those you can safely control.
 - Do not turn sharply. Use care when reversing.
 - Use counterweight(s) or wheel weights when suggested in the instruction handbook.
- Lightning can cause severe injury or death. If you see lightning or hear thunder in the area, do not operate the machine; seek shelter.
- Watch out for traffic when crossing or near roadways.
- Stop the blades rotating before crossing surfaces other than grass.

Toro Riding Mower Safety

The following paragraph contains safety information specific to Toro products that is not included in the CEN standard.

Use only Toro-approved attachments. The warranty may be voided if you use the machine with unapproved attachments.

- When using any attachments, never direct discharge of material toward bystanders nor allow anyone near the machine while in operation.
- Never operate the machine with damaged guards or without safety protective devices in place.
- Do not change the engine governor settings or overspeed the engine. Operating the engine at excessive speed can increase the hazard of personal injury.
- Before leaving the operator's position:
 - disengage the power take-off and lower the attachments;
 - change into neutral and set the parking brake;
 - stop the engine and remove the key.
- Disengage drive to attachments, stop the engine, and disconnect the spark plug wire(s) or remove the ignition key
 - before clearing blockages or unclogging chute;
 - before checking, cleaning or working on the lawn mower;
 - after striking a foreign object. Inspect the lawn mower for damage and make repairs before restarting and operating the equipment;
 - if the machine starts to vibrate abnormally (check immediately).
- Disengage drive to attachments when transporting or not in use.
- Stop the engine and disengage drive to attachment
 - before refuelling;
 - before removing the grass catcher;
 - before making height adjustment unless adjustment can be made from the operator's position.

Maintenance and Storage

- Keep all nuts, bolts and screws tight to be sure the equipment is in safe working condition.
- Never store the equipment with fuel in the tank inside a building where fumes can reach an open flame or spark.
- Allow the engine to cool before storing in any enclosure.
- To reduce the fire hazard, keep the engine, silencer, battery compartment and fuel storage area free of grass, leaves, or excessive grease.
- Check the grass catcher frequently for wear or deterioration.
- Replace worn or damaged parts for safety.
- If the fuel tank has to be drained, this should be done outdoors.
- On multi-bladed machines, take care as rotating one blade can cause other blades to rotate.
- When machine is to be parked, stored or left unattended, lower the cutting means unless a positive mechanical lock is used.

Sound Pressure

This unit has a sound pressure level at the operator's ear of 85.8 dBA, which includes an Uncertainty Value (K) of 0.8 dBA. The sound pressure level was determined according to the procedures outlined in EN 836.

Sound Power

This unit has a guaranteed sound power level of 99.1 dBA, which includes an Uncertainty Value (K) of 0.4 dBA. The sound power level was determined according to the procedures outlined in ISO 11094.

Hand-Arm Vibration

Measured vibration level for left hand = 2.7 m/s²

Measured vibration level for right hand = 3.5 m/s²

Uncertainty Value (K) = 1.2 m/s²

Measured values were determined according to the procedures outlined in EN 836.

Whole Body Vibration

Measured vibration level = 1.6 m/s²

Uncertainty Value (K) = 0.44 m/s²

Measured values were determined according to the procedures outlined in EN 836.

Slope Indicator

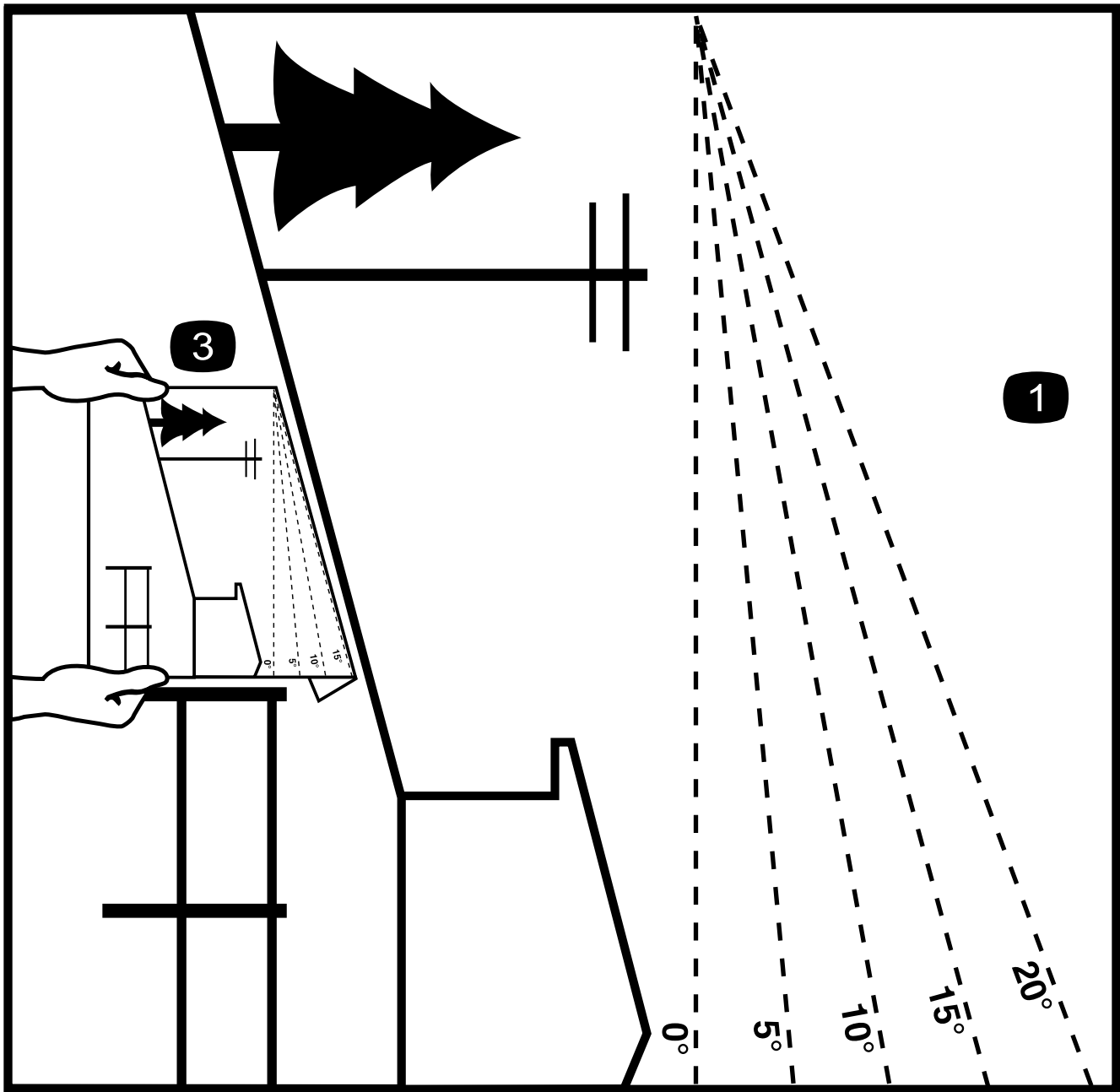

G011841

2

Figure 3

This page may be copied for personal use.

1. The maximum slope you can safely operate the machine on is **10 degrees** when mowing on side hills and **15 degrees** when mowing uphill or downhill. Use the slope chart to determine the degree of slope of hills before operating. **Do not operate this machine on a slope greater than 15 degrees.** Fold along the appropriate line to match the recommended slope.
2. Align this edge with a vertical surface, a tree, building, fence pole, etc.
3. Example of how to compare slope with folded edge.

Safety and Instructional Decals



Safety decals and instructions are easily visible to the operator and are located near any area of potential danger. Replace any decal that is damaged or lost.



93-7276

1. Explosion hazard—wear eye protection.
2. Caustic liquid/chemical burn hazard—to perform first aid, flush with water.
3. Fire hazard—no fire, open flames, or smoking.
4. Poison hazard—keep children a safe distance from the battery.

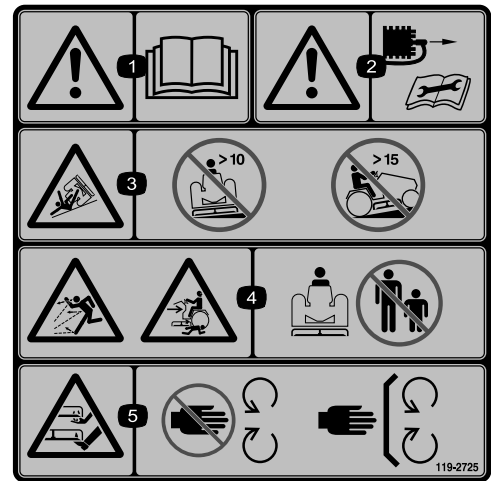

119-2725

1. Warning—read the *Operator's Manual*.
2. Warning—remove the spark plug wire before performing any maintenance on the machine.
3. Tipping hazard—do not operate on slopes greater than 10 degrees.
4. Thrown object hazard; crushing hazard, bystanders—keep bystanders a safe distance from the machine.
5. Cutting hazard of hand or foot—stay away moving parts, keep all guards and shields in place.



99-5340

1. KeyChoice—turn to enable reverse mowing.



119-5515

1. To drive the machine, push the lever in. 2. To push the machine, pull the lever out.



119-2726

1. Thrown object hazard—keep bystanders a safe distance from the machine.
2. Cutting hazard of hand or foot—stay away moving parts, keep all guards and shields in place.

Product Overview

Controls

Become familiar with the controls (Figure 4 and Figure 5) before you start the engine and operate the machine.

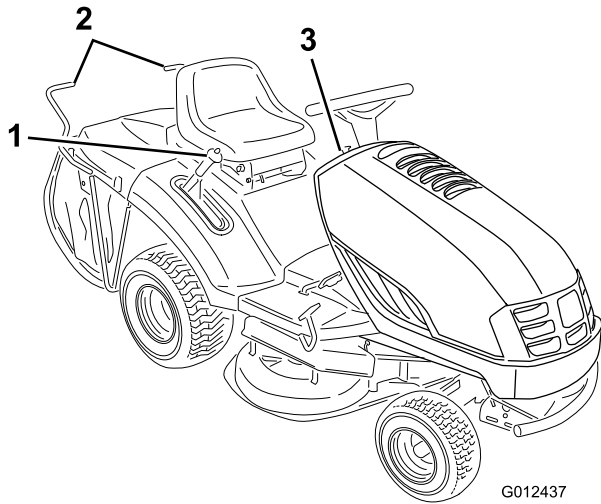

Figure 4

- 1. Height-of-cut lever
- 2. Grass collector dump lever
- 3. Dashboard controls

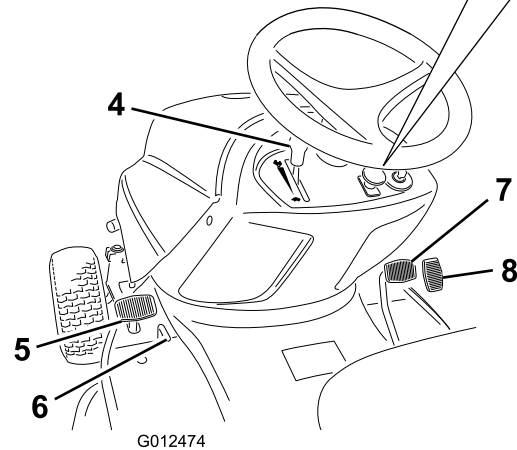
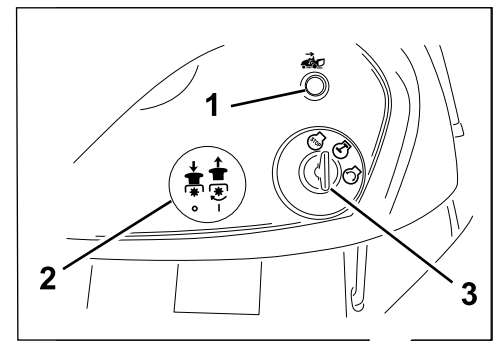

Figure 5

- 1. Operating-in-reverse indicator light
- 2. Blade control (PTO) knob
- 3. Ignition switch
- 4. Throttle control lever
- 5. Brake pedal
- 6. Parking brake lever
- 7. Forward speed pedal
- 8. Reverse speed pedal

Specifications

Model	Weight	Length	Width	Height
74560	262 kg	232 cm	95 cm	104 cm

Operation

Note: Determine the left and right sides of the machine from the normal operating position.

Filling the Fuel Tank

Recommended Fuel:

- For best results, use only clean, fresh (less than 30 days old), unleaded gasoline with an octane rating of 87 or higher ((R+M)/2 rating method).
- **Ethanol:** Gasoline with up to 10% ethanol (gasohol) or 15% MTBE (methyl tertiary butyl ether) by volume is acceptable. Ethanol and MTBE are not the same. Gasoline with 15% ethanol (E15) by volume is not approved for use. **Never use gasoline that contains more than 10% ethanol by volume**, such as E15 (contains 15% ethanol), E20 (contains 20% ethanol), or E85 (contains up to 85% ethanol). Using unapproved gasoline may cause performance problems and/or engine damage which may not be covered under warranty.
- **Do not** use gasoline containing methanol.
- **Do not** store fuel either in the fuel tank or fuel containers over the winter unless a fuel stabilizer is used.
- **Do not** add oil to gasoline.

Important: To reduce starting problems, add fuel stabilizer to the fuel all season, mixing it with gasoline less than 30 days old; run the machine dry before storing it for more than 30 days.

Do not use fuel additives other than a fuel stabilizer/conditioner. Do not use fuel stabilizers with an alcohol base such as ethanol, methanol, or isopropanol.

▲ DANGER

Gasoline is extremely flammable and explosive. A fire or explosion from gasoline can burn you and others.

- To prevent a static charge from igniting the gasoline, place the container and/or machine directly on the ground before filling, not in a vehicle or on an object.
- Fill the tank outdoors when the engine is cold. Wipe up spills.
- Do not handle gasoline when smoking or around an open flame or sparks.
- Store gasoline in an approved fuel container, out of the reach of children.

1. Stop the engine and wait for all moving parts to stop.
2. Clean around the fuel tank cap and remove it.
3. Add unleaded regular gasoline to the fuel tank until the level is 1/4 to 1/2 inch (6 to 13 mm) below the

bottom of the filler neck. **Do not fill the fuel tank completely full.**

Note: This space in the tank allows gasoline to expand.

4. Install the fuel tank cap securely.
5. Wipe up any gasoline that may have spilled.

Checking the Engine Oil Level

Before you start the engine and use the machine, check the oil level in the engine crankcase; refer to Checking the Engine Oil Level in Servicing the Engine Oil in the Maintenance section.

Using the Parking Brake

Always set the parking brake whenever you stop the machine or leave it unattended.

Setting the Parking Brake

1. Push the brake pedal (Figure 5) down and hold it.
2. Set the parking brake.
3. Slide the parking brake lever over (Figure 5) and gradually take your foot off the brake pedal.

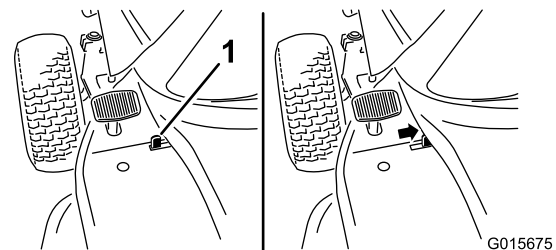

Figure 6

1. Parking brake lever

Note: The clutch/brake pedal should stay in the depressed (locked) position.

Releasing the Parking Brake

1. Push down on the brake pedal (Figure 5).

Note: The parking brake lever should release.

2. Gradually release the brake pedal.

Positioning the Seat

The seat can move forward and backward. Position the seat where you have the best control of the machine and are most comfortable.

1. Raise the seat and loosen the adjustment knobs (Figure 7).

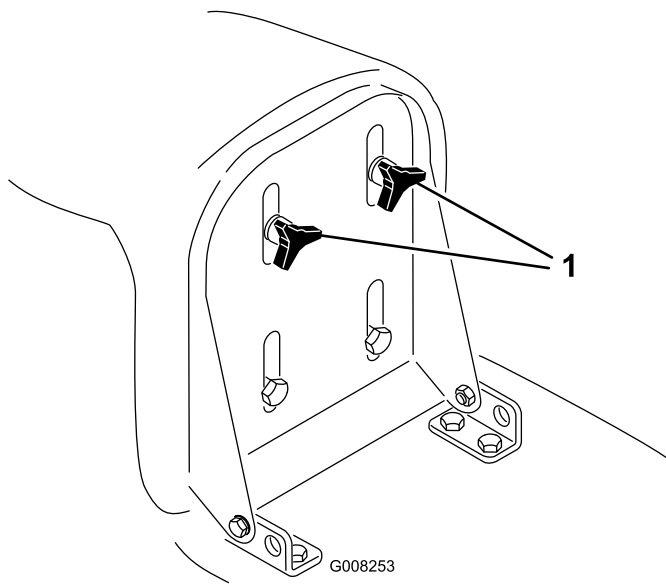

Figure 7

1. Adjustment knobs

2. Move the seat to the desired position and tighten the knobs.

Using the Blade Control (PTO)

The blade control (PTO) knob engages and disengages power to the blades.

Engaging the Blades

1. Depress the brake pedal to stop the machine.
2. Pull the blade control (PTO) knob out to the Engaged position (Figure 5).

Disengaging the Blades

1. Depress the brake pedal to stop the machine.
2. Push the blade control (PTO) knob into the Disengaged position (Figure 5).

Setting the Height of Cut

Use the height-of-cut lever to raise and lower the mower to the desired cutting height. You can set the cutting height to 7 different positions from approximately 30 to 80 mm (1-1/4 to 3-1/8 inches).

Important: You must set the height-of-cut lever to the highest position (7) when you transport the machine off the lawn to prevent damaging the blades.

1. Push and hold in the button on the height-of-cut lever (Figure 8).

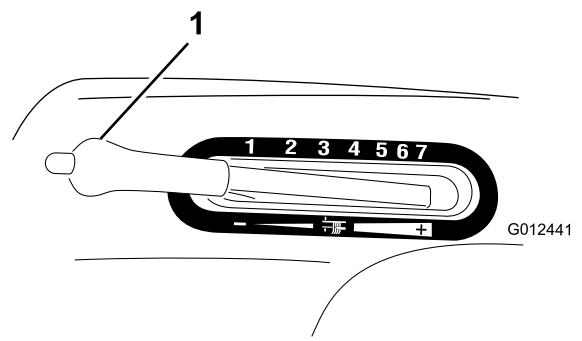

Figure 8

1. Height-of-cut lever

2. Shift the height-of-cut lever to the desired position.
3. Release the button.

Starting the Engine

1. Open the fuel shut-off valve located between the fuel tank and the engine (Figure 9).

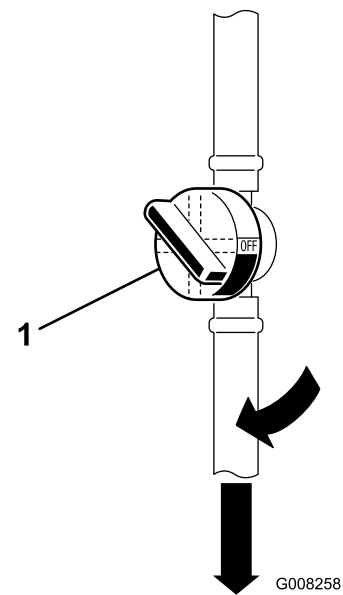

Figure 9

1. Fuel shut-off valve

Note: The valve handle should align with the fuel hose.

2. Sit down on the seat.
3. Set the parking brake; refer to Using the Parking Brake.
4. Disengage the blades (PTO); refer to Figure 5.

Note: The engine will not start if the blades (PTO) are engaged.

5. When starting a cold engine, shift the throttle control lever to the Choke (all the way up) position (Figure 10).

Stopping the Engine

1. Move the throttle control lever to the Slow (turtle) position (Figure 10).

Note: If the engine backfires, shift the throttle control lever to the Fast (rabbit) position before stopping the engine.

2. Turn the ignition key to the Off position (Figure 11).

Note: If the engine has been working hard or is hot, let it idle for a minute before turning the ignition key to the Off position. This allows the engine to cool before you stop it. You may stop the engine in an emergency by turning the ignition key to the Off position.

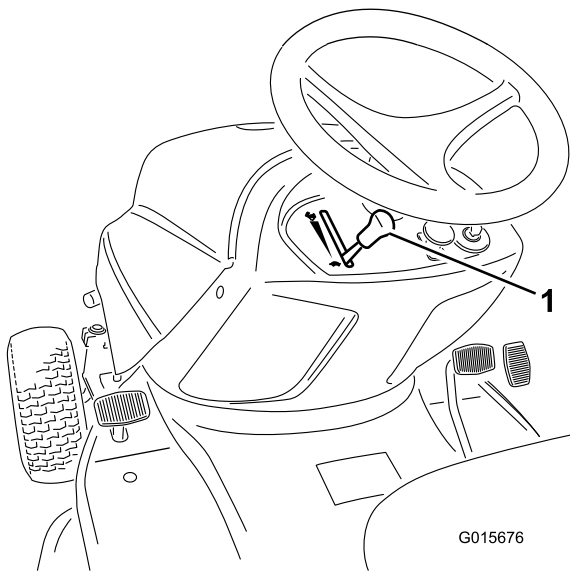

Figure 10

1. Throttle control lever

Note: To start a warm engine, shift the throttle control lever to the Fast (rabbit) position.

6. Shift the throttle control lever to the Slow (turtle) position (Figure 10).
7. Turn the ignition key clockwise and hold it in the Start position (Figure 11).

Note: When the engine starts, release the key.

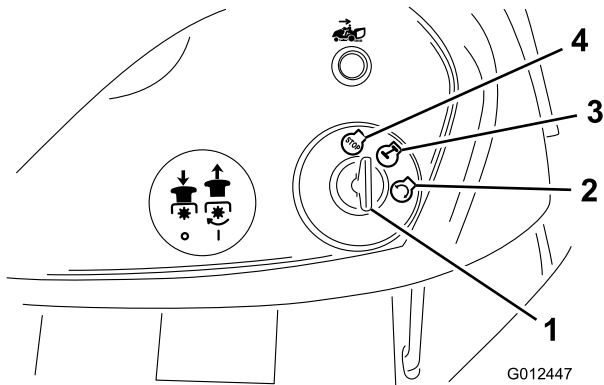

Figure 11

1. Ignition key
2. Start
3. On
4. Off

Important: If the engine does not start after 15 seconds of continuous cranking, turn the ignition key to Off and let the starter motor cool for 2 minutes; refer to **Troubleshooting**.

8. After the engine starts, slowly shift the throttle control lever to the Fast (rabbit) position.

Using the Safety Interlock System

Service Interval: Before each use or daily

⚠ CAUTION

If the safety interlock switches are disconnected or damaged, the machine could operate unexpectedly, causing personal injury.

- Do not tamper with the interlock switches.
- Check the operation of the interlock switches daily and replace any damaged switches before operating the machine.
- Replace switches every 2 years regardless of whether they are operating properly or not.

Understanding the Safety Interlock System

The safety interlock system is designed to prevent the engine from starting unless:

- You are sitting on the seat.
- The brake pedal is depressed.
- The blade control (PTO) knob is in the Disengaged position.
- The traction control pedal is in Neutral.

The safety interlock system stops the engine if you rise from the seat and the traction control pedal is not in the Neutral position, the parking brake is not set, or the blade control (PTO) knob is in the Engaged position.

The safety interlock system is designed to stop the mower if:

- You shift into Reverse with the blades (PTO) engaged.
- You remove the bag or dump the grass.

Setting the KeyChoice® Switch to Operate in Reverse

The interlock feature on the machine prevents the power take-off (PTO) from operating when you back up the machine. If you operate the machine in reverse with the blades (PTO) engaged (i.e., with the mower blades or other attachment running), the engine will stop. **Do not mow in reverse unless it is absolutely necessary.**

If you need to use the blades (PTO) while backing up, turn off the interlock feature using the KeyChoice switch located near the seat bracket (Figure 12).

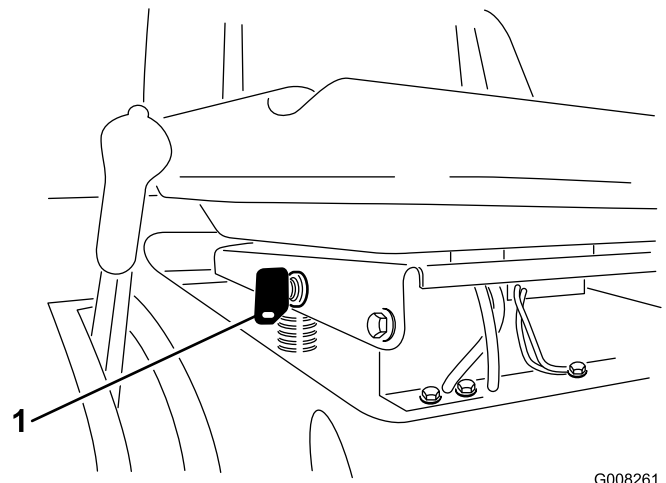

G008261

Figure 12

1. KeyChoice switch

⚠ DANGER

You could back over a child or bystander while the mower blades or other attachment is engaged and cause serious injury or death.

- Do not mow in reverse unless it is absolutely necessary.
- Do not insert the KeyChoice key unless it is absolutely necessary.
- Always look backward and down before backing up the machine.
- Use the KeyChoice switch only if you are certain that no children or other bystanders will enter the mowing area.
- Be very observant after deactivating the interlock because the sound of the engine may prevent you from noticing that a child or bystander has entered the work area.
- Always remove both the ignition and KeyChoice keys and put them in a safe place out of the reach of children or unauthorized users when you leave the machine unattended.

1. Engage the blades (PTO).
2. Insert the KeyChoice key into the switch (Figure 12).
3. Turn the KeyChoice key.

A red light on the front console (Figure 5) turns on, indicating that the interlock is disabled.

4. Operate the machine in reverse and complete your task.
5. Disengage the blades (PTO) to activate the interlock.
6. Remove the KeyChoice key and put it in a safe place out of the reach of children.

Testing the Safety Interlock System

⚠ CAUTION

If the safety interlock switches are disconnected or damaged, the machine could operate unexpectedly, causing personal injury.

- Do not tamper with the interlock switches.
- Check the operation of the interlock switches daily and replace any damaged switches before operating the machine.

Test the safety interlock system before you use the machine each time. If the safety interlock system does not operate as described below, have an Authorized Service Dealer repair the safety interlock system immediately. While sitting in the seat, perform the following checks:

1. Set the parking brake, shift the blade control (PTO) knob to the Engage position, and turn the ignition key to Start: The engine should not crank.
2. Shift the blade control (PTO) knob to the Disengage position, release the parking brake, and turn the ignition key to Start: The engine should not crank.
3. Set the parking brake, shift the blade control (PTO) knob to Disengage, and start the engine. While the engine is running, release the parking brake and rise slightly from the seat: The engine should stop.
4. Shift the blade control (PTO) knob into the Disengage position, put the traction control pedal in Neutral, and start the engine. While the engine is running, shift the blade control (PTO) knob into the Engage position and put the traction control pedal in Reverse: The engine should stop.
5. Shift the blade control (PTO) knob into the Disengage position and put the traction control pedal in Neutral. Start the engine, shift the blade control (PTO) knob into the Engage position, and turn the KeyChoice key and release it: The operating-in-reverse warning light should illuminate.
6. Shift the blade control (PTO) knob to the Disengage position: The operating-in-reverse warning light should turn off.

Pushing the Machine Manually

Important: Always push the machine manually. Never tow the machine because it may damage the transaxle.

To Push the Machine

1. Park the machine on a level surface.
2. Disengage the blades (PTO).

3. Set the parking brake.
4. Stop the engine and wait for all moving parts to stop.
5. Remove the ignition key.
6. Remove the grass collector; refer to Removing the Grass Collector.
7. Pull the drive control, located behind the right rear wheel, out to the Push position (Figure 13).

Note: This disengages the drive system and allows the wheels to turn freely.

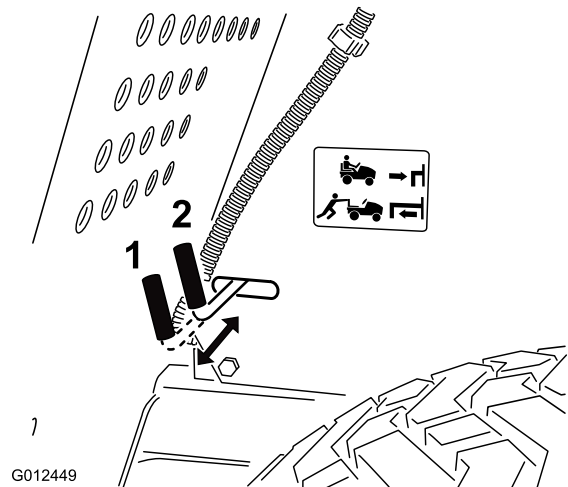

Figure 13

1. Push position
2. Operate position

8. Release the parking brake.

To Operate the Machine

1. Set the parking brake.
2. Push the drive control in to the Operate position (Figure 13) to engage the drive system.

Note: The machine will not drive unless the drive control is in the Operate position.

3. Install the grass collector; refer to Installing the Grass Collector.

Driving the Machine Forward or Backward

The throttle control regulates the engine speed as measured in RPM (revolutions per minute). Place the throttle control in the Fast position for best performance.

To go forward:

1. Release the parking brake; refer to Releasing the Parking Brake.
2. Place your foot on the traction control pedal and slowly press on the pedal to move forward (Figure 14).

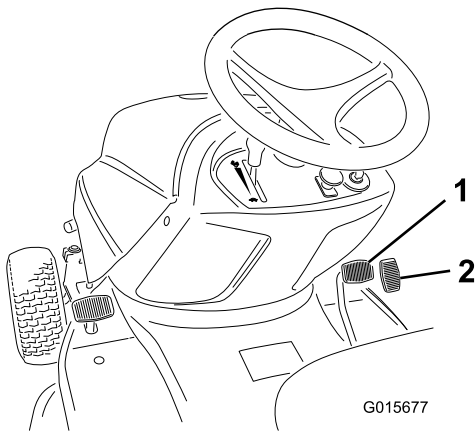

Figure 14

1. Forward control pedal 2. Reverse speed pedal

Note: To increase the speed, push the traction control pedal down. To decrease the speed, release the pressure on the traction control pedal.

To go backward:

1. Release the parking brake; refer to Releasing the Parking Brake.
2. Place your foot on the reverse speed pedal and slowly press on the pedal to move backward (Figure 14).

Note: To increase the speed, push the reverse speed pedal down. To decrease the speed, release the pressure on the reverse speed pedal.

Important: To avoid transmission damage, always release the parking brake before moving the traction control pedal or the reverse speed pedal.

Important: To prevent damage to the mower, always set the mower to the highest cutting position when you drive the machine off the lawn.

Stopping the Machine

1. Release the traction control pedal or the reverse speed pedal.
2. Disengage the blades (PTO).
Turn the ignition key to the Off position.
3. Set the parking brake if you leave the machine unattended; refer to Using the Parking Brake.

Note: Remove the keys from the ignition and KeyChoice switches.

⚠ CAUTION

Children or bystanders may be injured if they move or attempt to operate the machine while it is unattended.

Always remove the ignition and KeyChoice keys and set the parking brake when leaving the machine unattended, even if it is just for a few minutes.

Emptying the Grass Collector

When the grass collector is full, a buzzer sounds, and the grass collector must then be emptied.

Important: To prevent the discharge tunnel from getting clogged, disengage the blades (PTO) when the buzzer sounds.

1. If the locking pin is in the locked position, unlock it (Figure 15).

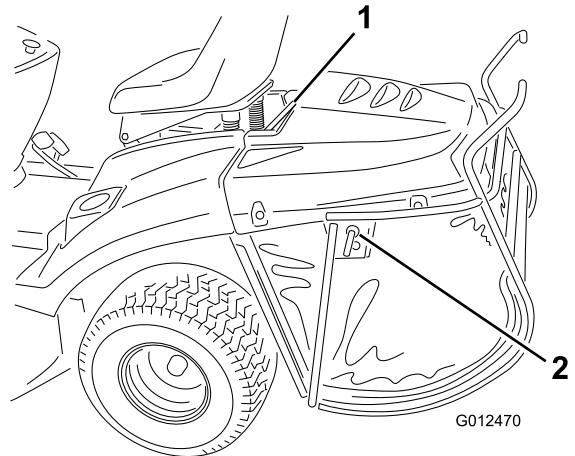

Figure 15

1. Top support bar 2. Locking pin

2. Disengage the blades (PTO) and move the throttle to the Slow position.
3. Pull the grass collector dump lever forward to tilt the grass collector (Figure 16).

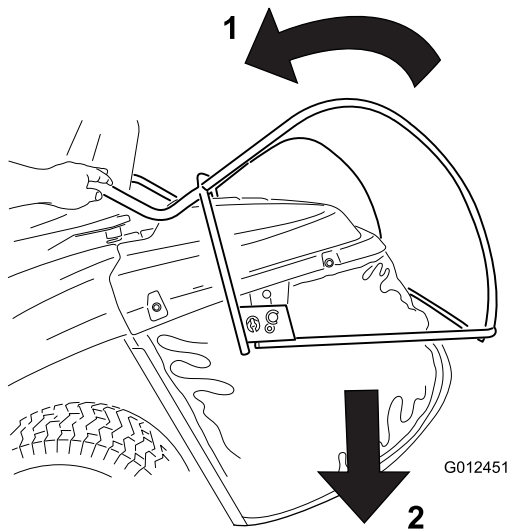

Figure 16

1. Pull the grass collector dump lever forward to empty the grass.

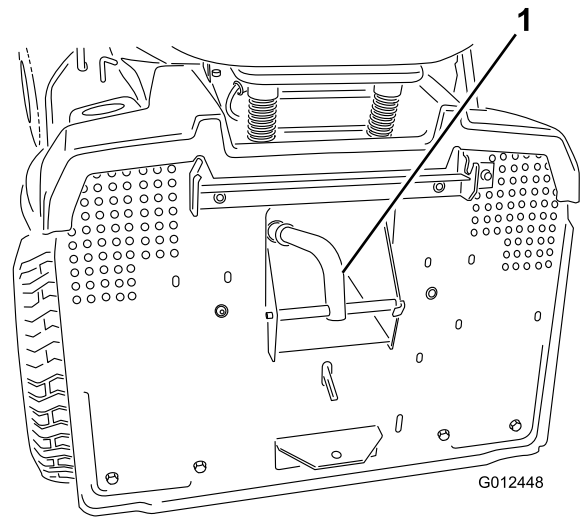

Figure 18

1. Mulch plug installed in the discharge chute at the rear of the machine
2. Discharge chute of the machine

4. Empty the grass collector.
5. Before returning the grass collector to the operating position, move the machine forward to clear the grass collector of the deposited grass.
6. Slowly lower the dump lever to return the grass collector to the operating position.

Important: Ensure that the mulch plug is seated properly so that it will not come into contact with the blades.

6. Install the grass collector; refer to Installing the Grass Collector.

Mulching the Grass

To mulch the grass clippings, you must install a mulch plug in the machine.

1. Disengage the blades (PTO).
2. Set the parking brake.
3. Stop the engine and wait for all moving parts to stop.
4. Remove the grass collector; refer to Removing the Grass Collector.
5. Insert the mulch plug (Figure 17) into the discharge opening at the rear of the machine, and hook it into the hole in the discharge chute (Figure 18).

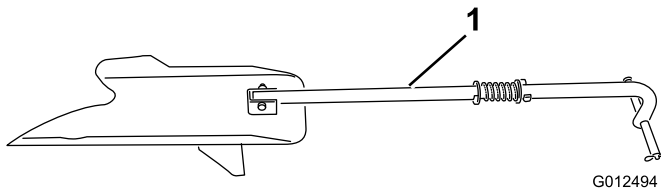

Figure 17

1. Mulch plug

Optional Towing Hitch

The machine is capable of towing non-ground-engaging attachments with a maximum weight of 150 kg (331 lb).

1. Remove the grass collector; refer to Removing the Grass Collector.
2. Install the attachment to the towing hitch located at the lower rear part of the machine (Figure 19).

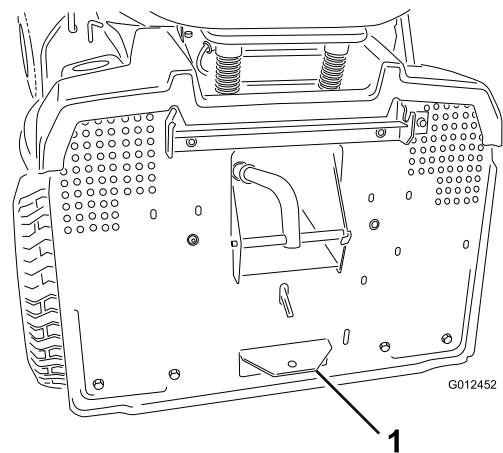

Figure 19

1. Towing hitch

Operating Tips

- For the best performance, operate the engine at the maximum speed. The mower requires air to thoroughly cut grass clippings, so do not set the height-of-cut too low or completely surround the mower in uncut grass. Always leave one side of the mower free from uncut grass to allow the air to be drawn into the mower.
- Cut the grass slightly longer than normal to ensure that the cutting height of the mower does not scalp any uneven ground. When cutting grass longer than 6 inches (15 cm) tall, cut the lawn twice to ensure an acceptable appearance.
- It is best to cut only about 1/3 of the grass blade when mulching. Do not cut more than that unless the grass is sparse or it is late fall when grass grows more slowly.
- Alternate the mowing direction to keep the grass standing straight. This also helps disperse clippings and enhances decomposition and fertilization.
- Grass grows at different rates at different times of the season. To maintain the same cutting height, which is a good practice, mow more often in early spring. As the grass growth rate slows in mid summer, mow less frequently.
- If the grass is longer than normal, or if it contains a high degree of moisture, raise the cutting height higher than usual, cut the grass at that setting, and then cut the grass again at the lower, normal setting.
- If you must stop the machine while mowing, you may leave a clump of grass clippings on your lawn. To avoid this, do the following:
 - Engage the blades and move to a previously cut area.
 - Disperse the clippings evenly by raising the mower 1 or 2 height-of-cut settings while driving forward with the blades engaged.
- Maintain sharp blades throughout the season. Sharp blades cut grass cleanly without tearing or shredding the grass blades. Tearing and shredding the grass turns it brown at the edges, which slows its growth and increases the chance of disease. Every 30 days, check the blades for sharpness and file down any nicks.

Maintenance

Note: Determine the left and right sides of the machine from the normal operating position.

Recommended Maintenance Schedule(s)

Maintenance Service Interval	Maintenance Procedure
After the first 5 hours	<ul style="list-style-type: none">• Change the engine oil.
Before each use or daily	<ul style="list-style-type: none">• Check the safety interlock system.• Check the engine oil level.• Check the battery electrolyte level.• Check the brake.• Check the blades.• Clean the mower housing.
Every 25 hours	<ul style="list-style-type: none">• Grease and lubricate the machine. (Grease and lubricate it more frequently when operating it in dusty or sandy conditions.)• Service the air filter. (Service it more frequently when operating the machine in dusty or dirty conditions.)• Check the spark plug.• Check the tire pressure.• Clean the outside of the engine.
Every 50 hours	<ul style="list-style-type: none">• Change the engine oil. (Change it more frequently when operating the machine in dusty or dirty conditions.)
Every 100 hours	<ul style="list-style-type: none">• Replace the air filter. (Replace it more frequently when operating the machine in dusty or dirty conditions.)• Change the engine oil filter. (Change it more frequently when operating the machine in dusty or dirty conditions.)• Replace the spark plug.• Replace the fuel filter.• Check the front-to-rear blade slope. (Also check it whenever you install the mower.)
Yearly or before storage	<ul style="list-style-type: none">• Perform all the maintenance procedures listed above.• Check the belts for wear and cracks.• Drain the fuel tank.• Paint chipped surfaces.• Charge the battery and disconnect the cables.

Important: Refer to your engine operator's manual for additional maintenance procedures.

▲ CAUTION

If you leave the key in the ignition switch, someone could accidentally start the engine and seriously injure you or other bystanders.

Remove the key from the ignition and disconnect the wire from the spark plug before you do any maintenance. Set the wire aside so that it does not accidentally contact the spark plug.

Lubrication

when operating it in dusty or sandy conditions.)

Greasing and Lubricating the Machine

Service Interval: Every 25 hours/Yearly (whichever comes first)—Grease and lubricate the machine. (Grease and lubricate it more frequently

How to Grease the Machine

Grease the machine with a general-purpose grease.

1. Disengage the blades (PTO).
2. Set the parking brake.

3. Stop the engine and wait for all moving parts to stop.
4. Remove the ignition key.
5. Clean the grease fittings with a rag. Scrape any paint off the front of the fittings.
6. Connect a grease gun to each fitting and pump grease into it.
7. Wipe up any excess grease.

Where to Add Grease

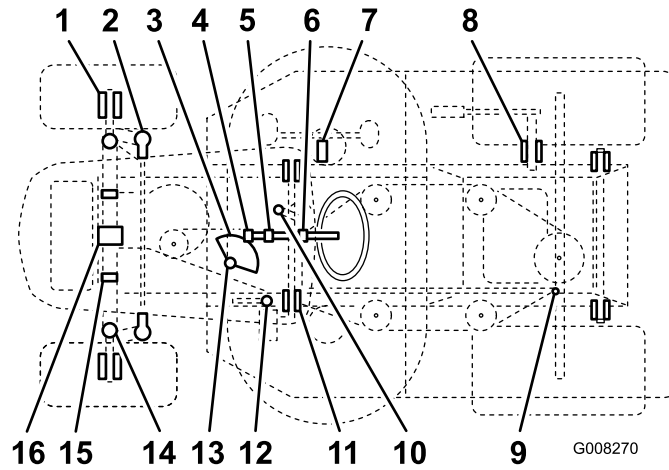

Figure 20

Item	Name	Quantity (pumps)	Interval (hours)	Lubricant
1	Front wheel—grease fittings	2	25	Grease
2	Steering ball joints	4	50	Oil
3	Steering sector gear	1	50	Grease
4	Steering pinion gear	1	25	Grease
5	Steering shaft bearing	1	50	Oil
6	Steering shaft bearing	1	50	Oil
7	Motion lever	1	50	Grease
8	Shaft hub for lifting the mower housing	1	50	Oil
9	Motion link ball joints	4	50	Oil
10	Traction idler pulley belt—grease fitting	1	50	Grease
11	Brake pedal shaft pivot points	2	50	Oil
12	Parking brake ring	1	50	Oil
13	Steering bearing	1	25	Grease
14	Left and Right Spindle—grease fittings	2	25	Grease
15	Mower housing hinged pins	6	When removed	Grease
16	Front axle pivot pins	2	When removed	Grease

Engine Maintenance

Servicing the Air Cleaner

Service Interval: Every 25 hours—Service the air filter. (Service it more frequently when operating the machine in dusty or dirty conditions.)

Every 100 hours—Replace the air filter. (Replace it more frequently when operating the machine in dusty or dirty conditions.)

1. Park the machine on a level surface.

2. Disengage the blades (PTO).
3. Set the parking brake.
4. Stop the engine and wait for all moving parts to stop.
5. Remove the ignition key.

Removing the Air Filter

1. Clean around the air filter cover to prevent dirt from getting into the engine and causing damage.
2. Turn the knobs to the unlock position (Figure 21).

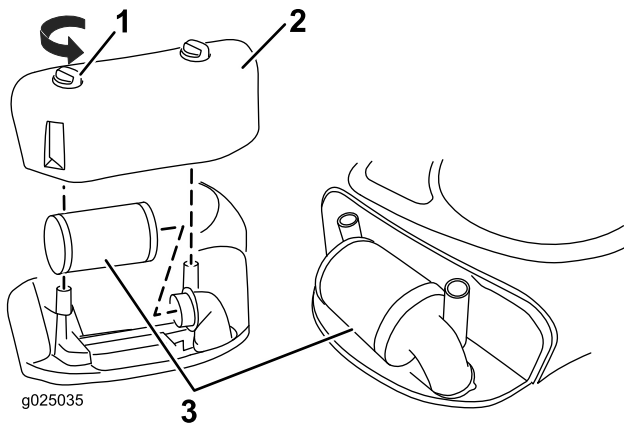

Figure 21

1. Knob (2)
2. Air filter cover
3. Air filter

3. Remove the air filter cover.
4. To remove the filter, lift the end of the filter (Figure 21).

Cleaning the Air Filter

1. Inspect the air filter for tears, an oily film, or damage to the rubber seal.
2. To loosen debris, gently tap the filter on a hard surface. If the filter is excessively dirty, replace it with a new filter.

Important: Never clean the air filter with pressurized air or liquids, such as solvents, gasoline, or kerosene. Replace the air filter if it is damaged or cannot be cleaned thoroughly.

Installing the Air Filter

1. Install the air filter into the engine base and push down until the filter snaps in place.
2. Install the air filter cover and knobs (Figure 21).
3. Close the hood.

Servicing the Engine Oil

Oil Type: Detergent oil (API service SF, SG, SH, SJ, or higher)

Crankcase capacity: 48 oz. or (1.4 l) with filter; 44 oz. or (1.3 l) without filter

Viscosity: See the oil table (Figure 22).

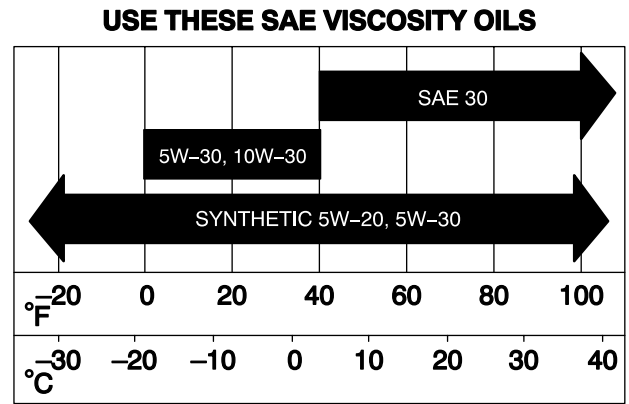

Figure 22

Checking the Engine Oil Level

Service Interval: Before each use or daily

1. Park the machine on a level surface.
2. Disengage the blades (PTO).
3. Set the parking brake.
4. Stop the engine and wait for all moving parts to stop.
5. Remove the ignition key.
6. Open the hood.
7. Clean around the dipstick (Figure 23) so that dirt cannot fall into the filler hole and damage the engine.

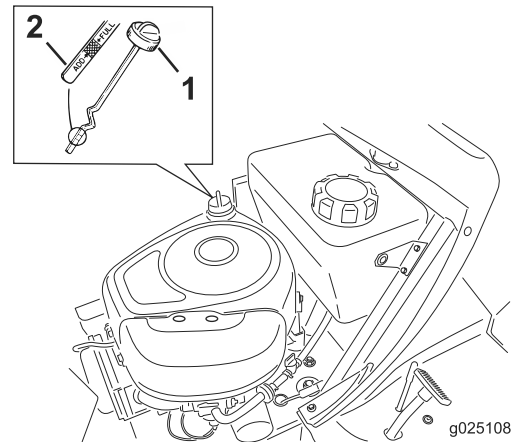

Figure 23

1. Dipstick
2. Metal end
8. Unscrew the dipstick and wipe the metal end clean (Figure 23).
9. Screw the dipstick fully onto the filler tube (Figure 23).
10. Unscrew the dipstick again and look at the metal end. If the engine oil level is low, slowly pour only enough oil into the filler tube to raise the level to the Full mark on the dipstick.

Important: Do not overfill the crankcase with engine oil and run the engine; engine damage may result.

Changing the Engine Oil

Service Interval: After the first 5 hours

Every 50 hours (Change it more frequently when operating the machine in dusty or dirty conditions.)

1. Start the engine and let it run for 5 minutes.

Note: This warms the oil so that it drains better.

2. Park the machine so that the drain side is slightly lower than the other side to ensure that the oil drains completely.
3. Disengage the blades (PTO).
4. Set the parking brake.
5. Stop the engine and wait for all moving parts to stop.
6. Remove the ignition key.
7. Open the hood.
8. Place a pan below the drain plug.
9. Remove the drain plug to allow the oil to drain (Figure 28).

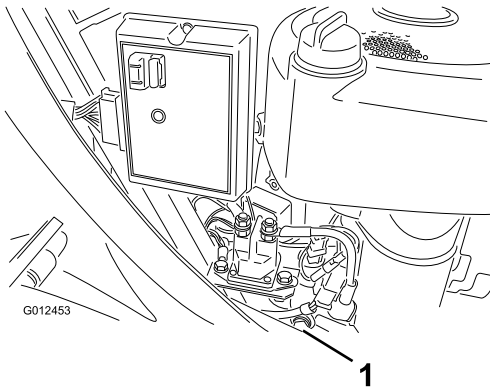

Figure 24

1. Oil drain plug

10. When the oil has drained completely, insert the drain plug and tighten it securely.

Note: Recycle the used engine oil properly.

11. Clean around the dipstick and unscrew the cap (Figure 23).
12. Slowly pour approximately 80% of the engine oil into the filler tube (Figure 23).
13. Check the engine oil level; refer to steps 9 and 10 of Checking the Engine Oil Level.

Changing the Engine Oil Filter

Service Interval: Every 100 hours (Change it more frequently when operating the machine in dusty or dirty conditions.)

1. Drain the oil from the engine; refer to Changing the Engine Oil.
2. Remove the old filter and wipe off the adapter gasket surface (Figure 25).

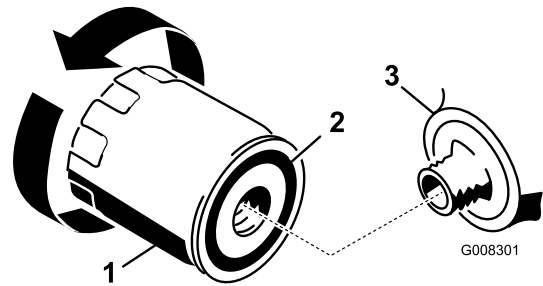

Figure 25

1. Engine oil filter
2. Gasket
3. Adapter

3. Apply a thin coat of new engine oil to the rubber gasket on the new filter (Figure 25).
4. Install the new filter to the filter adapter by turning it clockwise until the gasket contacts the filter adapter.
5. Tighten the filter an additional 1/2 to 3/4 turn (Figure 25).
6. Fill the crankcase with the proper type of new engine oil; refer to Checking the Engine Oil Level.

Servicing the Spark Plug

Service Interval: Every 25 hours—Check the spark plug.

Every 100 hours—Replace the spark plug.

Use a Champion RC12YC or equivalent spark plug.

Ensure that the air gap between the center and side electrodes is 0.030 inch (0.76 mm) before installing the spark plug. Use a spark plug wrench for removing and installing the spark plug and a gapping tool or feeler gauge to check and adjust the air gap.

Removing the Spark Plug

1. Disengage the blades (PTO).
2. Set the parking brake.
3. Stop the engine and wait for all moving parts to stop.
4. Remove the ignition key.
5. Open the hood.
6. Disconnect the wire from the spark plug (Figure 26).

Fuel System Maintenance

Draining the Fuel Tank

Drain the fuel tank when you will not be using the machine for more than 30 days.

▲ DANGER

In certain conditions, gasoline is extremely flammable and highly explosive. A fire or explosion from gasoline can burn you and others and can damage property.

- Drain gasoline from the fuel tank when the engine is cold. Do this outdoors in an open area. Wipe up any gasoline that spills.
- Never smoke when draining gasoline, and stay away from an open flame or where a spark may ignite the gasoline fumes.

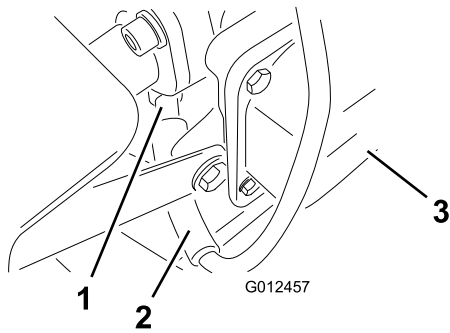

Figure 26

1. Spark plug
2. Spark plug wire
3. Front of engine

7. Clean around the spark plug to prevent dirt from falling into the engine and potentially causing damage.
8. Remove the spark plug and the metal washer (Figure 26).

Checking the Spark Plug

1. Look at the center of the spark plug (Figure 27). If you see light brown or gray on the insulator, the engine is operating properly. A black coating on the insulator usually means that the air cleaner is dirty.

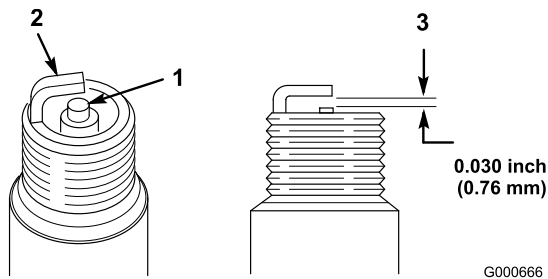

Figure 27

1. Center electrode insulator
2. Side electrode
3. Air gap (not to scale)

Important: Do not clean the spark plug. Always replace the spark plug when it has a black coating, worn electrodes, an oily film, or cracks.

2. Check the gap between the center and side electrodes (Figure 27) and bend the side electrode if the gap is not correct.

Installing the Spark Plug

1. Install the spark plug and metal washer. Ensure that the air gap is set correctly.
2. Tighten the spark plug to 15 ft-lb (20.4 N-m).
3. Connect the wire to the spark plug (Figure 26).
4. Close the hood.

1. Park the machine so that the left front side is slightly lower than the right side to ensure that the fuel tank drains completely.
2. Disengage the blades (PTO).
3. Set the parking brake.
4. Stop the engine and wait for all moving parts to stop.
5. Remove the ignition key.
6. Close the fuel shut-off valve located under the front of the fuel tank.
7. Loosen the hose clamp at the fuel filter and slide it up the fuel line away from the fuel filter (Figure 28).

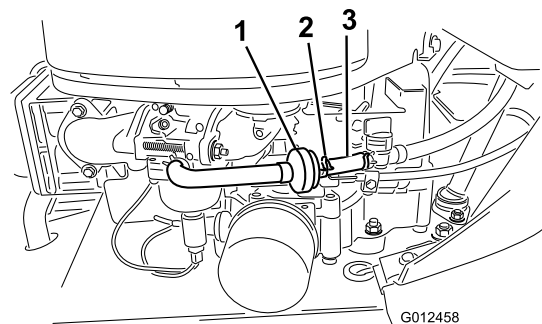

Figure 28

1. Fuel filter
2. Hose clamp
3. Fuel line

8. Pull the fuel line off the fuel filter (Figure 28).
9. Open the fuel shut-off valve and allow the gasoline to drain into an approved fuel container or a drain pan.

Note: Now is the best time to install a new fuel filter because the fuel tank is empty.

10. Install the fuel line onto the fuel filter.
11. Slide the hose clamp close to the fuel filter to secure the fuel line (Figure 28).

Replacing the Fuel Filter

Service Interval: Every 100 hours/Yearly (whichever comes first)

The best time to replace the fuel filter (Figure 28) is when the fuel tank is empty. Never install a dirty fuel filter after it has been removed from the fuel line.

1. Park the machine on a level surface.
2. Disengage the blades (PTO).
3. Set the parking brake.
4. Stop the engine and wait for all moving parts to stop.
5. Remove the ignition key.
6. Close the fuel shut-off valve (Figure 29).

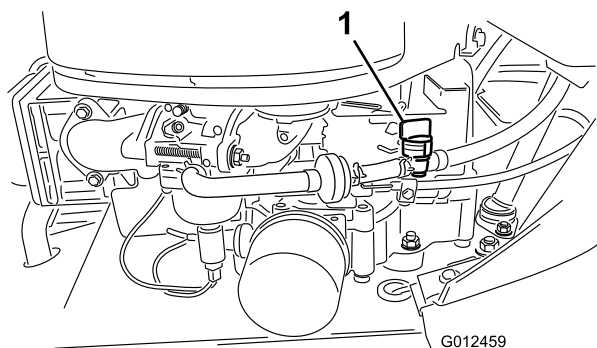

Figure 29

1. Fuel shut-off valve

7. Squeeze the ends of the hose clamps together and slide them away from the old fuel filter (Figure 29).
8. Remove the old fuel filter from the fuel line.
9. Install a new fuel filter and move the hose clamps close to it.
10. Open the fuel shut-off valve.

Electrical System Maintenance

Replacing the Fuses

The electrical system is protected by fuses. They are located beneath the hood, near the fuel tank (Figure 30). If a fuse goes out, check the circuit wiring for a short.

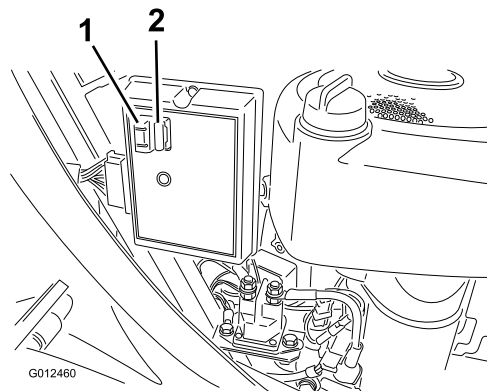

Figure 30

1. Fuses

To replace a fuse, pull up to remove the old fuse from the socket. Insert a new fuse by pushing it down into the socket.

Note: Ensure that the new fuse has the same amperage as the old fuse that you are replacing.

Servicing the Battery

Always keep the battery clean and fully charged. Use a paper towel to clean the battery and battery box. If the battery terminals are corroded, clean them with a solution of 4 parts water and 1 part baking soda. Apply a light coating of grease to the battery terminals to prevent them from corroding.

Battery voltage and amperage: 12 volts, 190 cold cranking amps

Removing the Battery

⚠ WARNING

Battery terminals or metal tools could short against metal machine components causing sparks. Sparks can cause the battery gasses to explode, resulting in personal injury.

- When removing or installing the battery, do not allow the battery terminals to touch any metal parts of the machine.
- Do not allow metal tools to short between the battery terminals and the metal parts of the machine.

1. Disengage the blades (PTO).
2. Set the parking brake.
3. Stop the engine and wait for all moving parts to stop.
4. Remove the ignition key.
5. Lift up the seat to see the battery.
6. Lift the rubber cover up off the negative (black) cable.
7. Disconnect the negative (black) ground cable from the battery post (Figure 31).

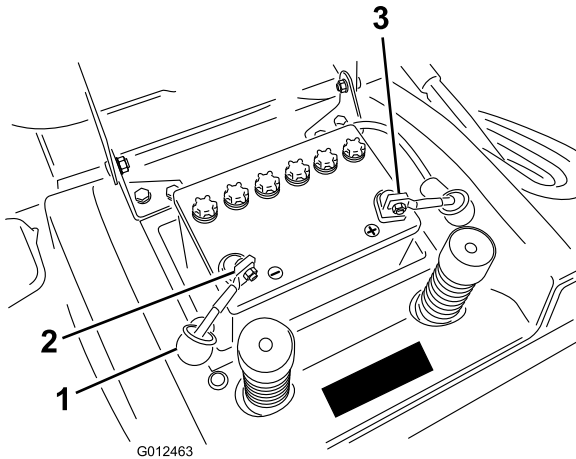

Figure 31

1. Rubber cover
2. Negative cable (black), boot not shown for clarity
3. Positive cable (red)

⚠ WARNING

Routing the battery cables improperly could damage the machine and cables, causing sparks. Sparks can cause the battery gasses to explode, resulting in personal injury.

- Always disconnect the negative (black) battery cable before disconnecting the positive (red) cable.
 - Always connect the positive (red) battery cable before connecting the negative (black) cable.
8. Lift the rubber cover up off the positive (red) cable.
 9. Disconnect the positive (red) cable from the battery post (Figure 31).
 10. Remove the battery hold down rod.
 11. Remove the battery from the chassis.

Installing the Battery

1. Place the battery into the chassis with the battery posts toward the rear of the machine (Figure 31).
2. Secure the battery in the chassis with the hold down rod.

3. Using the bolt and wing nut, connect the positive (red) cable to the positive (+) battery post (Figure 31). Slide the rubber cover over the battery post.
4. Using the bolt and wing nut, connect the negative (black) cable to the negative (-) battery post (Figure 31). Slide the rubber cover over the battery post.

Checking the Electrolyte Level

Service Interval: Before each use or daily

1. Tip the seat forward to see the battery.
2. Look at the side of the battery. The electrolyte must be up to the upper line (Figure 32).

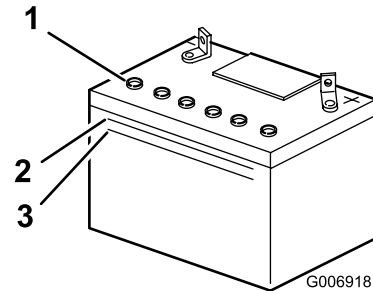

Figure 32

1. Filler caps
2. Upper line
3. Lower line

Note: do not allow the electrolyte to fall below the lower line (Figure 32).

3. If the electrolyte is low, add the required amount of distilled water; refer to Adding Water to the Battery.

⚠ DANGER

Battery electrolyte contains sulfuric acid which is a deadly poison and causes severe burns.

- Do not drink electrolyte and avoid contact with skin, eyes or clothing. Wear safety glasses to shield your eyes and rubber gloves to protect your hands.
- Fill the battery where clean water is always available for flushing the skin.

Adding Water to the Battery

The best time to add distilled water to the battery is just before you operate the machine. This lets the water mix thoroughly with the electrolyte solution.

1. Clean the top of the battery with a paper towel.
2. Remove the filler caps (Figure 32).
3. Slowly pour distilled water into each battery cell until the level is up to the lower part of the tube (Figure 32).

Important: Do not overfill the battery. Electrolyte (sulfuric acid) can severely corrode and damage the chassis.

4. Replace the filler caps.

Charging the Battery

⚠ WARNING

Charging the battery produces gasses that can explode. Never smoke near the battery and keep sparks and flames away from the battery.

Important: Always keep the battery fully charged (1.260 specific gravity), especially below 32°F (0°C) to prevent battery damage.

1. Remove the battery from the chassis; refer to Removing the Battery.
2. Check the electrolyte level; refer to Checking the Electrolyte Level.
3. Remove the filler caps from the battery and connect a 2 amp battery charger to the battery posts.
4. Charge the battery at a rate of 2 amps or less for 4 hours (12 volts). **Do not overcharge the battery.**
5. When the battery is fully charged, install the filler caps.
6. Install the battery in the chassis; refer to Installing the Battery.

Drive System Maintenance

Checking the Tire Pressure

Service Interval: Every 25 hours/Yearly (whichever comes first)

Maintain the air pressure in the front tires at 100 kPa and in the rear tires at 80 kPa. Check the pressure at the valve stem (Figure 33). Check the tires when they are cold to get the most accurate pressure reading.

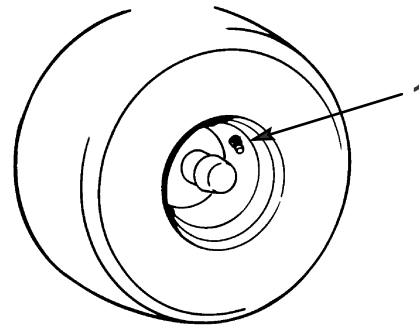

m-1872

Figure 33

1. Valve stem

Servicing the Brake

The brake is located on the right side of the rear axle, inside the rear tire (Figure 34).

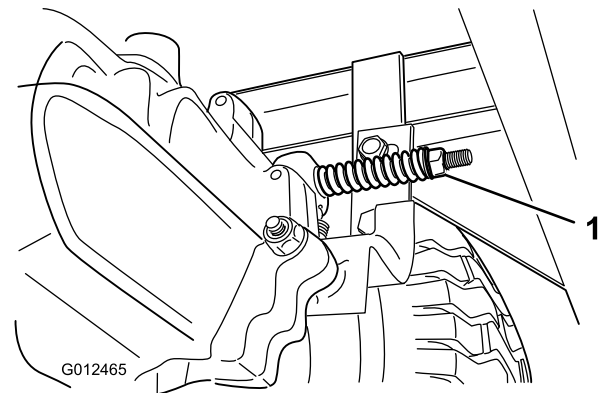

Figure 34

1. Brake adjusting nut

If the machine takes more than 1 m (3 ft.) to stop at high speed in the highest gear, adjust the brake.

Checking the Brake

Service Interval: Before each use or daily

1. Park the machine on a level surface.
2. Disengage the blades (PTO).

3. Set the parking brake.
4. Stop the engine and wait for all moving parts to stop.
5. Remove the ignition key.
6. Pull the drive control out to the Push position (Figure 13).
7. If the rear wheels lock and skid when you push the machine forward, you do not need to adjust the brake. If the wheels turn and do not lock, adjust the brake; refer to Adjusting the Brake.

Adjusting the Brake

1. Check the brake before you adjust it; refer to Checking the Brake.
2. Ensure that the drive control is in the Operate position (Figure 13) and that the parking brake is on.
3. Turn the brake adjusting nut clockwise until you cannot push the machine (Figure 34).
4. Release the parking brake and ensure that the rear wheels rotate freely when you push the machine. If they do not, turn the brake adjusting nut counterclockwise just enough so that you can push the machine.
5. Check the brake operation again; refer to Checking the Brake.

Servicing the Grass Collector

Removing the Grass Collector

1. Lock the locking pin on the grass collector (Figure 35).

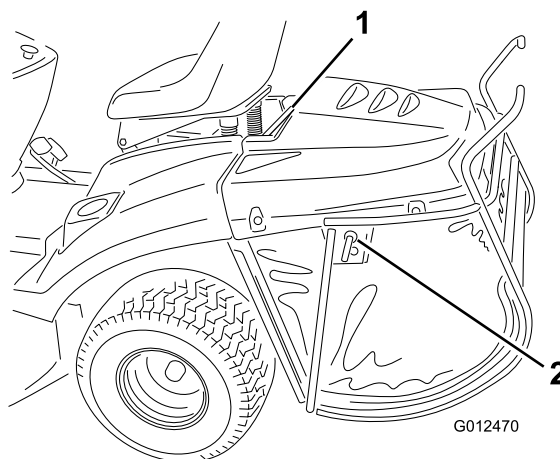

Figure 35

- | | |
|--------------------|------------------------------------|
| 1. Top support bar | 3. Locking pin (unlocked position) |
| 2. Locking pin | 4. Locking pin (locked position) |

2. Lift up the collector using the top support bar (Figure 35).

Installing the Grass Collector

1. Hang the top support bar onto the 2 notches in the support bracket at the rear of the machine (Figure 36).

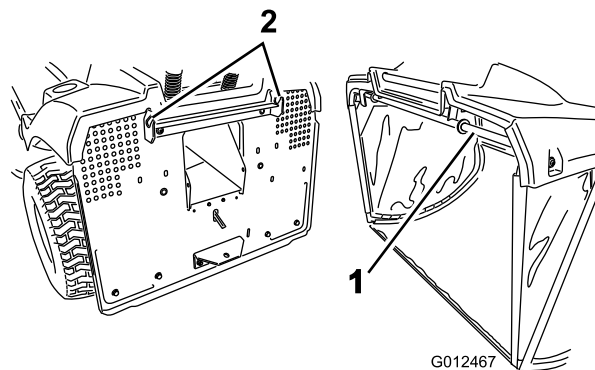

Figure 36

- | | |
|--------------------|---|
| 1. Top support bar | 2. Notches in collector support bracket |
|--------------------|---|

Note: Ensure that the grass collector is properly seated on the mower. The mower will not function unless the grass collector is properly attached.

2. Unlock the locking pin to allow for emptying the grass collector.

Cleaning the Grass Collector and Tunnel

1. Disengage the blades (PTO).
2. Set the parking brake.
3. Stop the engine and wait for all moving parts to stop.
4. Remove the ignition key.
5. Remove the grass collector; refer to Removing the Grass Collector.
6. Clean the collector bag with pressurized water.
7. Wipe the area around the full-bag sensor.
8. Clean the inside of the discharge tunnel all the way to the mower.
9. Install the grass collector; refer to Installing the Grass Collector.

Note: Allow the bag to dry thoroughly before installing it.

Mower Deck Maintenance

Servicing the Blades

Service Interval: Before each use or daily

Note: Determine the left and right sides of the machine from the normal operating position.

To ensure a superior quality of cut, keep the blades sharp. For convenient sharpening and replacement, keep extra blades.

▲ DANGER

Worn or damaged blades can break and a piece of the blade could be thrown into the operator's or bystander's area, resulting in serious personal injury or death.

- Inspect the blades periodically for wear or damage.
- Replace worn or damaged blades.

Inspecting the Blades

1. Remove the mower; refer to Removing the Mower.
2. Inspect the cutting edges (Figure 37). If the edges are not sharp or have nicks, remove the blades and sharpen them; refer to Sharpening the Blades.

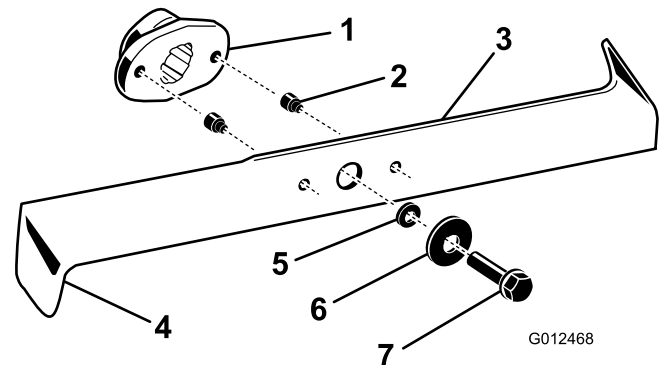

Figure 37

- | | |
|------------------|--------------|
| 1. Blade driver | 4. Bent edge |
| 2. Shear pin (2) | 5. Washer |
| 3. Blade | 6. Bolt |

3. Inspect the blades, especially the bent edges (Figure 37). If you notice any wear or damage in this area, immediately install new blades.
4. If the shear pins are broken, replace them immediately (Figure 37).

Important: If the shear pins are broken, the mower belt may be damaged. Inspect the belt; if the belt is damaged, contact an Authorized Service Dealer.

Removing the Blades

1. Remove the mower; refer to Removing the Mower.
 2. Carefully tip the mower over.
 3. Remove the bolts, washers, and blades (Figure 37). Wedge a block of wood between each blade and the mower to lock the blade when you are removing each bolt.
- Note:** The right blade has a left-hand threaded bolt.
4. Inspect all parts; replace any that are worn or damaged.

Sharpening the Blades

1. Use a file to sharpen the cutting edge at both ends of each blade (Figure 38). Maintain the original angle. The blade retains its balance if you remove the same amount of material from both cutting edges.

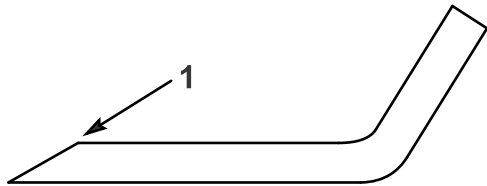

Figure 38

m-1854

1. Sharpen at original angle

2. Check the balance of each blade by putting it on a blade balancer (Figure 39). If the blade stays in a horizontal position, the blade is balanced and can be used. If the blade is not balanced, file some metal off the back side of the blade. Repeat this step until each blade is balanced.

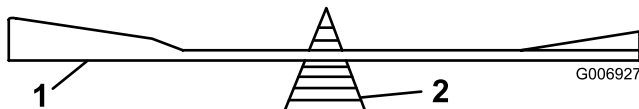

Figure 39

G006927

1. Blade
2. Balancer

Installing the Blades

1. Install the blades, washers, and blade bolts (Figure 37).
Important: The bent edges of the blades must be pointing toward the top of the mower to ensure proper cutting.
2. Tighten the blade bolts to 37 ft-lb (50 N-m).

Removing the Mower

1. Park the machine on a level surface.
2. Disengage the blades (PTO).
3. Set the parking brake.
4. Stop the engine and wait for all moving parts to stop.

5. Remove the ignition key.
6. Disconnect the wire from the spark plug.
7. Move the height-of-cut lever to the lowest position.
8. If the mulch plug is installed, remove it; refer to Removing the Mulch Plug.
9. Remove the belt from the clutch pulley (Figure 40).

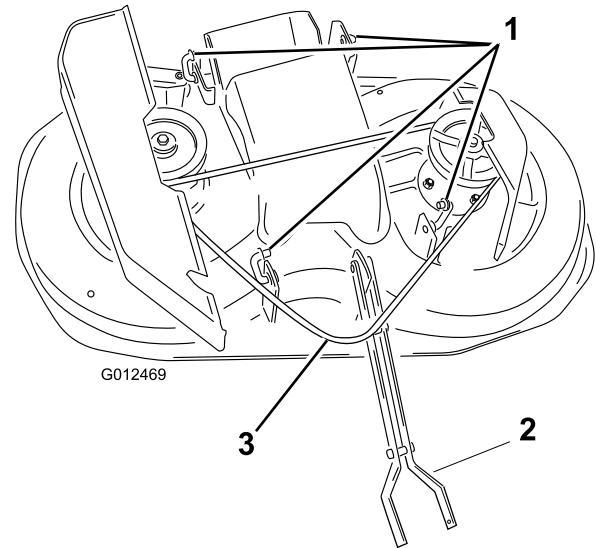

Figure 40

G012469

1. Links
2. Front linkage
3. Belt—indicated at the point around clutch pulley (not shown)

10. Remove the 2 bolts and nuts from the front linkage, and pull apart the front linkage to remove it from the machine.
11. Remove the pins from the 4 rear links and remove the links from the tractor (Figure 40).
Note: You can leave the links attached to the mower as shown in (Figure 40).
12. Lift up on the mower end of the discharge chute to free the mower from the notches in the discharge chute.
13. Pull the mower deck out from under the left side of the machine.

Installing the Mower

Reverse the procedure for Removing the Mower.

Adjusting the Front-to-Rear Blade Slope

Check the front-to-rear blade slope whenever you install the mower.

1. Measure the distance between the front tip of the left blade and the flat surface (Figure 41). Repeat for the rear tip of the left blade.

Leveling the Mower from Side-to-Side

The mower blades must be level from side to side. Check the side-to-side level whenever you install the mower or if you notice that your lawn has an uneven appearance.

- Carefully rotate the blades side to side (Figure 43).

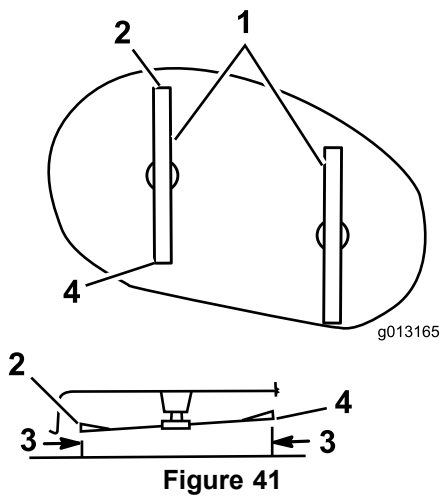

Figure 41

Top and side views of mower housing

- | | |
|----------------------------|---------------------------|
| 1. Blades front to rear | 3. Measure here |
| 2. Front tip of left blade | 4. Rear tip of left blade |

Note: The distance from the front tip of the left blade to the flat surface should be approximately 6 mm (1/4 inch) lower than the distance from the rear tip of the left blade and the flat surface. If so, go to Leveling the Mower from Side-to-Side. Otherwise, go to the next step.

- To obtain the proper height distance between the front and rear tips of the left blade, adjust the length of the linking rod (located on the left side of the machine) (Figure 42).

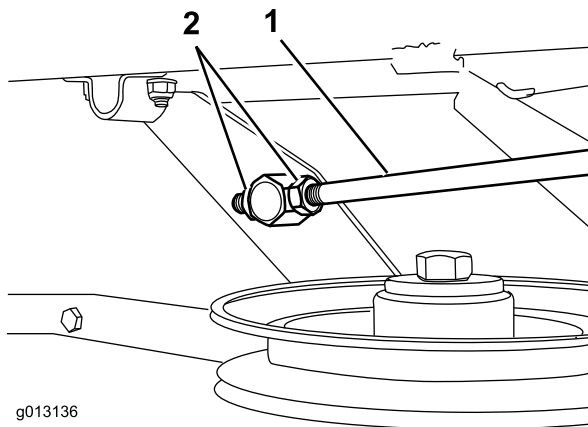

Figure 42

View from left side of machine

- | | |
|----------------|---------|
| 1. Linking rod | 2. Nuts |
|----------------|---------|

Note: Shorten the linking rod to decrease the blade slope; extend the linking rod to increase the blade slope.

- Ensure that the front-to-rear blade slope is correct, then check the side-to-side level of the mower; refer to Leveling the Mower from Side-to-Side.

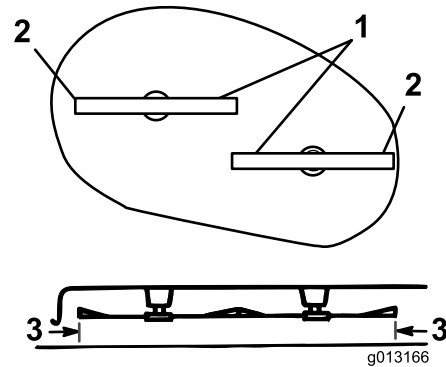

Figure 43

Top and side views of mower housing

- | | |
|----------------------------|-----------------|
| 1. Blades side to side | 3. Measure here |
| 2. Outside edges of blades | |

- Measure between the outside cutting edges and the flat surface (Figure 43). Ensure that the measurements are within 3 mm (1/8 inch) of each other. If they are not, go to the next step.
- Loosen the nuts on the front and rear adjustable links (located on the right side of the mower) so that the links are free to move through the trunnions (Figure 44 and Figure 45).

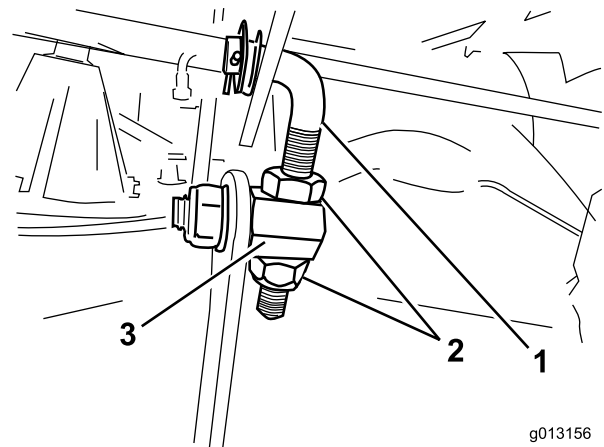

Figure 44

Front adjustable link (view from front of machine)

- | | |
|--------------------------|-------------|
| 1. Front adjustable link | 3. Trunnion |
| 2. Nuts | |

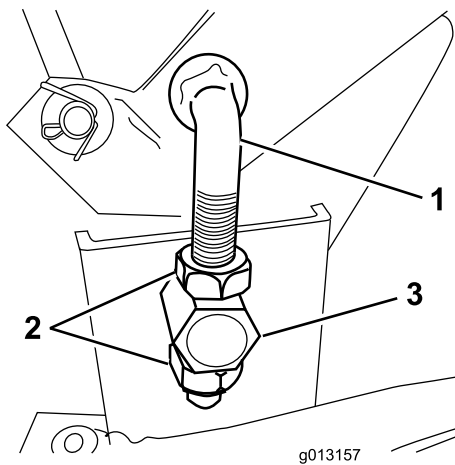

Figure 45

Rear adjustable link (view from right side of machine)

- | | |
|-------------------------|-------------|
| 1. Rear adjustable link | 3. Trunnion |
| 2. Nuts | |

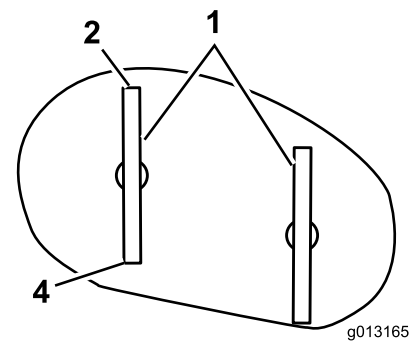

Figure 46

Top and side views of mower housing

- | | |
|----------------------------|---------------------------|
| 1. Blades front to rear | 3. Measure here |
| 2. Front tip of left blade | 4. Rear tip of left blade |

4. Raise or lower the right side of the mower housing by turning the nuts until the distance from the outside edges of the blades to the flat surface (Figure 43) are within 3 mm (1/8 inch) of each other, and tighten the nuts on the front and rear adjustable links.

7. Measure the distance between the front tip of the left blade and the flat surface (Figure 46).

Note: The distance should be 55 mm (2-1/8 inch). If it is, go to step Adjusting the Front-to-Rear Blade Slope. Otherwise, go to the next step.

8. Loosen the jam nut on at the end of the turnbuckle (on the right side of the machine; refer to Figure 47), and adjust the turnbuckle until the distance between the front tip of the left blade and the flat surface is 55 mm (2-1/8 inch).

Checking and Setting the Cutting Height

Service Interval: Every 100 hours/Yearly (whichever comes first)—Check the front-to-rear blade slope. (Also check it whenever you install the mower.)

Before you check the slope, inflate the front and rear tires to the recommended air pressure; refer to Checking the Tire Pressure. If the front of the mower is not within 4 to 11 mm (1/8 to 3/8 inch) lower than the rear of the mower, adjust the blade slope.

Check and adjust the cutting height of the blades whenever you install the mower.

1. Park the machine on a level surface.
2. Ensure that the air pressure in the tires are set to the recommended level; refer to Checking the Tire Pressure.
3. Disengage the blades (PTO) and set the parking brake.
4. Stop the engine, wait for all moving parts to stop, and remove the ignition key.
5. Disconnect the wire from the spark plug.
6. Move the height-of-cut lever to the middle (4) position. Carefully rotate the blades front to rear (Figure 46).

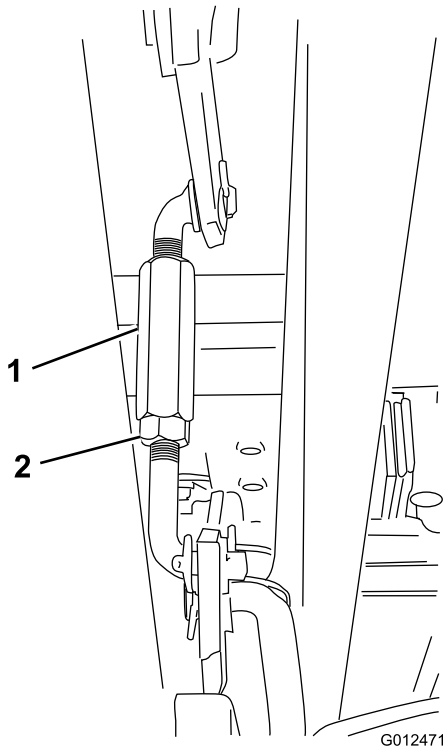

Figure 47

Height-of-cut linkage (on right side of machine)

1. Turnbuckle
2. Jam nut

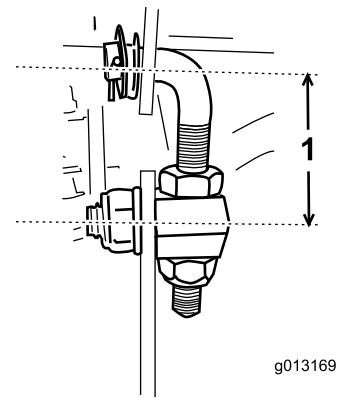

Figure 48

1. Front adjustable link: 55 mm (2-1/8 inches)
Rear adjustable link: 50 mm (2 inches)

Note: You may need to move the height-of-cut lever to the lowest (1) position before you adjust the turnbuckle. Return the cutting height setting to the middle (4) position before checking the distance between the front tip of the left blade and the flat surface.

Note: To raise the blade tip, turn the turnbuckle clockwise; to lower the blade tip, turn the turnbuckle counterclockwise.

9. Tighten the turnbuckle jam nut.

Installing the Adjustable Links

If you install a replacement adjustable link, you must approximately adjust the new adjustable link before setting the cutting height, adjusting the front-to-rear slope, and leveling the mower from side-to-side.

Install the front or rear adjustable link as shown in Figure 48.

Storage

1. Disengage the blades (PTO).
2. Set the parking brake.
3. Stop the engine and wait for all moving parts to stop.
4. Remove the ignition key.
5. Remove the grass collector and clean it; refer to Grass Collector.
6. Remove grass clippings, dirt, and grime from the external parts of the entire machine, especially the engine. Clean the dirt and chaff from the outside of the engine cylinder head fins and blower housing.

Important: You can wash the machine with a mild detergent and water. Do not use pressurized liquids to wash the machine. Pressurized liquids may damage the electrical system or wash away necessary grease at the friction points. Avoid using water excessively, especially near the control panel, lights, engine, and battery.

7. Check the brake; refer to Brake.
8. Service the air cleaner; refer to Servicing the Air Cleaner.
9. Grease the chassis; refer to Greasing and Lubricating the Machine.
10. Change the engine oil and filter; refer to Servicing the Engine Oil.
11. Check the tire pressure; refer to Checking the Tire Pressure.
12. When storing the machine over 30 days, prepare it as follows:
 - A. Add a petroleum-based stabilizer/conditioner to the fuel in the tank according to the instructions from the stabilizer manufacturer. **Do not use an alcohol-based stabilizer (ethanol or methanol).**

Note: A fuel stabilizer/conditioner is most effective when mixed with fresh gasoline and used at all times.

 - B. Run the engine for 5 minutes to distribute the conditioned fuel through the fuel system.
 - C. Stop the engine, allow it to cool, and drain the fuel tank; refer to Draining the Fuel Tank
 - D. Start the engine and run it until it stops.
 - E. Choke or prime the engine.
 - F. Start and run the engine until it will not start again.
 - G. Recycle the old fuel according to local codes.
 - H. Close the fuel shut-off valve.

Important: Do not store stabilizer/conditioned gasoline over 90 days.

13. Remove and inspect the spark plug; refer to Servicing the Spark Plug. With the spark plug removed from the engine, pour 2 tablespoons of engine oil into the spark plug hole. Use the electric starter to crank the engine and distribute the oil inside the cylinder. Install the spark plug, but do not connect the wire to the spark plug.
14. Disconnect the negative battery cable. Clean the battery and battery terminals. Check the electrolyte level and charge it fully; refer to Servicing the Battery. Leave the negative battery cable disconnected from the battery during storage.

Important: The battery must be fully charged to prevent it from freezing and being damaged at temperatures below 32°F (0°C). You can store a fully charged battery during the winter without recharging.
15. Check and tighten all bolts, nuts, and screws. Repair or replace any part that is worn or damaged.
16. Paint all scratched or bare metal surfaces with paint available from an Authorized Service Dealer.
17. Store the machine in a clean, dry garage or storage area. Remove the ignition and KeyChoice keys from the mower and keep them in a memorable place. Cover the machine to protect it and keep it clean.

Troubleshooting

Problem	Possible Cause	Corrective Action
The starter does not crank.	<ol style="list-style-type: none"> 1. The blade control (PTO) knob is engaged. 2. The parking brake is not on. 3. The battery is dead. 4. The electrical connections are corroded or loose. 5. A fuse is blown. 6. A relay or switch is damaged. 	<ol style="list-style-type: none"> 1. Move the blade control (PTO) knob to the Disengaged position. 2. Set the parking brake. 3. Charge the battery. 4. Check the electrical connections for good contact. 5. Replace the fuse. 6. Contact an Authorized Service Dealer.
The engine overheats.	<ol style="list-style-type: none"> 1. The engine load is excessive. 2. The oil level in the crankcase is low. 3. The cooling fins and air passages under the engine blower housing are plugged. 	<ol style="list-style-type: none"> 1. Reduce the ground speed. 2. Add engine oil to the crankcase. 3. Remove the obstruction from the cooling fins and air passages.
The machine does not drive.	<ol style="list-style-type: none"> 1. The drive control is in the Push position. 2. The traction belt is worn, loose, or broken. 3. The traction belt is off the pulley. 	<ol style="list-style-type: none"> 1. Move the drive control to the Operate position. 2. Contact an Authorized Service Dealer. 3. Contact an Authorized Service Dealer.
The engine will not start, starts hard, or fails to keep running.	<ol style="list-style-type: none"> 1. The operator is not seated. 2. The fuel tank is empty. 3. The air cleaner is dirty. 4. The spark plug wire is loose or disconnected. 5. A spark plug is pitted, fouled, or the gap is incorrect. 6. The choke is not closing. 7. There is dirt in the fuel filter 8. The idle speed is too low or the mixture is incorrect. 9. Dirt, water, or stale fuel is in the fuel system. 10. The fuel shut-off valve is closed. 	<ol style="list-style-type: none"> 1. Sit on the seat. 2. Fill the fuel tank with gasoline. 3. Clean or replace the air cleaner element. 4. Install the wire on the spark plug. 5. Install a new, correctly-gapped spark plug. 6. Adjust the throttle cable. 7. Replace the fuel filter. 8. Contact an Authorized Service Dealer. 9. Contact an Authorized Service Dealer. 10. Open the fuel shut-off valve.
The engine loses power.	<ol style="list-style-type: none"> 1. The engine load is excessive. 2. The air cleaner is dirty. 3. The oil level in the crankcase is low. 4. The cooling fins and air passages under the engine blower housing are plugged. 5. The spark plug is pitted, fouled, or the gap is incorrect. 6. The vent hole in the fuel cap is plugged. 7. There is dirt in the fuel filter. 8. Dirt, water, or stale fuel is in the fuel system. 	<ol style="list-style-type: none"> 1. Reduce your ground speed. 2. Clean the air cleaner element. 3. Add engine oil to the crankcase. 4. Remove the obstruction from the cooling fins and air passages. 5. Install a new, correctly-gapped spark plug. 6. Clean or replace the fuel cap. 7. Replace the fuel filter. 8. Contact an Authorized Service Dealer.

Problem	Possible Cause	Corrective Action
There is abnormal vibration.	<ol style="list-style-type: none"> 1. The blades are bent or unbalanced. 2. The blade mounting screws are loose. 3. The engine mounting bolts are loose. 4. There is a loose engine pulley, idler pulley, or blade pulley. 5. The engine pulley is damaged. 6. The blade drive belt is damaged. 	<ol style="list-style-type: none"> 1. Install a new blades. 2. Tighten the blade mounting screws. 3. Tighten the engine mounting bolts. 4. Tighten the appropriate pulley. 5. Contact an Authorized Service Dealer. 6. Contact an Authorized Service Dealer.
The blades do not rotate.	<ol style="list-style-type: none"> 1. The blade drive belt is worn, loose, or broken. 2. The blade drive belt is off the pulley. 3. The grass collector is not in place. 	<ol style="list-style-type: none"> 1. Contact an Authorized Service Dealer. 2. Contact an Authorized Service Dealer. 3. Install the grass collector.
The cutting height is uneven.	<ol style="list-style-type: none"> 1. The tire pressure is incorrect. 2. The mower is not level. 3. The underside of the mower is dirty. 4. The blade mounting screws are loose. 5. The blade drive belt tension is incorrect. 	<ol style="list-style-type: none"> 1. Set the tire pressure. 2. Adjust the height adjustment cable rod assembly. 3. Clean the underside of the mower. 4. Tighten the blade mounting screws. 5. Contact an Authorized Service Dealer.

Notes:

Notes:

International Distributor List

Distributor:	Country:	Phone Number:	Distributor:	Country:	Phone Number:
Agrolanc Kft	Hungary	36 27 539 640	Maquiver S.A.	Colombia	57 1 236 4079
Balama Prima Engineering Equip.	Hong Kong	852 2155 2163	Maruyama Mfg. Co. Inc.	Japan	81 3 3252 2285
B-Ray Corporation	Korea	82 32 551 2076	Mountfield a.s.	Czech Republic	420 255 704 220
Casco Sales Company	Puerto Rico	787 788 8383	Mountfield a.s.	Slovakia	420 255 704 220
Ceres S.A.	Costa Rica	506 239 1138	Munditol S.A.	Argentina	54 11 4 821 9999
CSSC Turf Equipment (pvt) Ltd.	Sri Lanka	94 11 2746100	Norma Garden	Russia	7 495 411 61 20
Cyril Johnston & Co.	Northern Ireland	44 2890 813 121	Oslinger Turf Equipment SA	Ecuador	593 4 239 6970
Cyril Johnston & Co.	Republic of Ireland	44 2890 813 121	Oy Hako Ground and Garden Ab	Finland	358 987 00733
Equivier	Mexico	52 55 539 95444	Parkland Products Ltd.	New Zealand	64 3 34 93760
Femco S.A.	Guatemala	502 442 3277	Perfetto	Poland	48 61 8 208 416
ForGarder OU	Estonia	372 384 6060	Pratoverde SRL.	Italy	39 049 9128 128
G.Y.K. Company Ltd.	Japan	81 726 325 861	Prochaska & Cie	Austria	43 1 278 5100
Geomechaniki of Athens	Greece	30 10 935 0054	RT Cohen 2004 Ltd.	Israel	972 986 17979
Golf international Turizm	Turkey	90 216 336 5993	Riversa	Spain	34 9 52 83 7500
Guandong Golden Star	China	86 20 876 51338	Lely Turfcare	Denmark	45 66 109 200
Hako Ground and Garden	Sweden	46 35 10 0000	Solvert S.A.S.	France	33 1 30 81 77 00
Hako Ground and Garden	Norway	47 22 90 7760	Spypros Stavrinides Limited	Cyprus	357 22 434131
Hayter Limited (U.K.)	United Kingdom	44 1279 723 444	Surge Systems India Limited	India	91 1 292299901
Hydroturf Int. Co Dubai	United Arab Emirates	97 14 347 9479	T-Markt Logistics Ltd.	Hungary	36 26 525 500
Hydroturf Egypt LLC	Egypt	202 519 4308	Toro Australia	Australia	61 3 9580 7355
Irrimac	Portugal	351 21 238 8260	Toro Europe NV	Belgium	32 14 562 960
Irrigation Products Int'l Pvt Ltd.	India	0091 44 2449 4387	Valtech	Morocco	212 5 3766 3636
Jean Heybroek b.v.	Netherlands	31 30 639 4611	Victus Emak	Poland	48 61 823 8369

European Privacy Notice

The Information Toro Collects

Toro Warranty Company (Toro) respects your privacy. In order to process your warranty claim and contact you in the event of a product recall, we ask you to share certain personal information with us, either directly or through your local Toro company or dealer.

The Toro warranty system is hosted on servers located within the United States where privacy law may not provide the same protection as applies in your country.

BY SHARING YOUR PERSONAL INFORMATION WITH US, YOU ARE CONSENTING TO THE PROCESSING OF YOUR PERSONAL INFORMATION AS DESCRIBED IN THIS PRIVACY NOTICE.

The Way Toro Uses Information

Toro may use your personal information to process warranty claims, to contact you in the event of a product recall and for any other purpose which we tell you about. Toro may share your information with Toro's affiliates, dealers or other business partners in connection with any of these activities. We will not sell your personal information to any other company. We reserve the right to disclose personal information in order to comply with applicable laws and with requests by the appropriate authorities, to operate our systems properly or for our own protection or that of other users.

Retention of your Personal Information

We will keep your personal information as long as we need it for the purposes for which it was originally collected or for other legitimate purposes (such as regulatory compliance), or as required by applicable law.

Toro's Commitment to Security of Your Personal Information

We take reasonable precautions in order to protect the security of your personal information. We also take steps to maintain the accuracy and current status of personal information.

Access and Correction of your Personal Information

If you would like to review or correct your personal information, please contact us by email at legal@toro.com.

Australian Consumer Law

Australian customers will find details relating to the Australian Consumer Law either inside the box or at your local Toro Dealer.



The Toro Warranty and The Toro GTS Starting Guarantee

Residential Products

Conditions and Products Covered

The Toro Company and its affiliate, Toro Warranty Company, pursuant to an agreement between them, jointly promise to repair for the original purchaser¹ the Toro Product listed below if defective in materials or workmanship or if the Toro GTS (Guaranteed to Start) engine will not start on the first or second pull, provided the routine maintenance required in the *Operator's Manual* have been performed.

The following time periods apply from the date of purchase:

Products	Warranty Period
Walk Power Mowers	
• Cast Deck	5 years Residential Use ² 90 Days Commercial Use
• Engine	5 years GTS Guarantee, Residential Use ³
• Battery	2 years
• Steel Deck	2 years Residential Use ² 30 Days Commercial Use
• Engine	2 years GTS Guarantee, Residential Use ³
TimeMaster Mowers	
• Engine	3 years Residential Use ² 90 Days Commercial Use
• Battery	3 years GTS Guarantee, Residential Use ³
• Engine	2 years
Electric Hand Held Products	2 years Residential Use ² No Warranty for Commercial Use
Snowthrowers	
• Single Stage	2 years Residential Use ² 45 Days Commercial Use
• Engine	2 years GTS Guarantee, Residential Use ³
• Two Stage	3 years Residential Use ² 45 Days Commercial Use
• Chute, chute deflector and impeller housing cover	Lifetime (original owner only) ⁵
Electric Snowthrowers	2 years Residential Use ² No Warranty for Commercial Use
All Ride-On Units Below	
• Engine	See engine manufacturer's warranty ⁴
• Battery	2 years Residential Use ²
• Attachments	2 years Residential Use ²
DH Lawn & Garden Tractors	2 years Residential Use ² 30 Days Commercial Use
XLS Lawn & Garden Tractors	3 years Residential Use ² 30 Days Commercial Use
TimeCutter	3 years Residential Use ² 30 Days Commercial Use
TITAN Mowers	
• Frame	3 years or 240 hours ⁵ Lifetime (original owner only) ⁶

¹Original Purchaser means the person who originally purchased the Toro Product.

²Residential use means use of the product on the same lot as your home. Use at more than one location is considered commercial use and the commercial use warranty would apply.

³The Toro GTS Starting Guarantee does not apply when the product is used commercially.

⁴Some engines used on Toro Products are warranted by the engine manufacturer.

⁵Whichever occurs first.

⁶Lifetime Frame Warranty - If the main frame, consisting of the parts welded together to form the tractor structure that other components such as the engine are secured to, cracks or breaks in normal use, it will be repaired or replaced, at Toro's option, under warranty at no cost for parts and labor. Frame failure due to misuse or abuse and failure or repair required due to rust or corrosion are not covered.

Warranty may be denied if the hour meter is disconnected, altered, or shows signs of being tampered with.

Owner Responsibilities

You must maintain your Toro Product by following the maintenance procedures described in the *Operator's Manual*. Such routine maintenance, whether performed by a dealer or by you, is at your expense.

Instructions for Obtaining Warranty Service

If you think that your Toro Product contains a defect in materials or workmanship, follow this procedure:

1. Contact your seller to arrange service of the product. If for any reason it is impossible for you to contact your seller, you may contact any Toro Authorized Distributor to arrange service. See attached Distributor List.
2. Bring the product and your proof of purchase (sales receipt) to the servicing outlet. If for any reason you are dissatisfied with the servicing outlet's analysis or with the assistance provided, contact us at:

Toro Customer Care Department, RLC Division
Toro Warranty Company
8111 Lyndale Avenue South
Bloomington, MN 55420-1196
001-952-948-4707

Items and Conditions Not Covered

There is no other express warranty except for special emission system coverage and engine warranty coverage on some products. This express warranty does not cover the following:

- Cost of regular maintenance service or parts, such as filters, fuel, lubricants, oil changes, spark plugs, air filters blade sharpening or worn blades, cable/linkage adjustments, or brake and clutch adjustments
- Components failing due to normal wear
- Any product or part which has been altered or misused or neglected and requires replacement or repair due to accidents or lack of proper maintenance
- Pickup and delivery charges
- Repairs or attempted repairs by anyone other than an Authorized Toro Service Dealer
- Repairs necessary due to failure to follow recommended fuel procedure (consult *Operator's Manual* for more details)
 - Removing contaminants from the fuel system is not covered
 - Use of old fuel (more than one month old) or fuel which contains more than 10% ethanol or more than 15% MTBE
 - Failure to drain the fuel system prior to any period of non-use over one month
- Repairs or adjustments to correct starting difficulties due to the following:
 - Failure to follow proper maintenance procedures or recommended fuel procedure
 - Rotary mower blade striking an object
- Special operational conditions where starting may require more than two pulls:
 - First time starts after extended period of non-use over three months or seasonal storage
 - Cool temperature starts such as those found in early spring and late autumn
 - Improper starting procedures - if you are having difficulty starting your unit, please check the *Operator's Manual* to ensure that you are using the correct starting procedures. This can save an unnecessary visit to an Authorized Toro Service Dealer.

General Conditions

The purchaser is covered by the national laws of each country. The rights to which the purchaser is entitled with the support of these laws are not restricted by this warranty.