



Count on it.

Parts Catalog

DH 140 Lawn Tractor

Model No. 74560—Serial No. 314000151 and Up



Ordering Replacement Parts

To order replacement parts, please supply the part number, the quantity, and the description of each part desired.

Understanding Reference Numbers

Each identified part in an illustration has a reference number. The reference number for a part also appears in the parts list, along with other information about the part.

This catalog uses two special reference number formats, one to indicate parts in a service assembly and another to indicate the quantity of a given part in an illustration.

Service Assembly Reference Numbers

Parts in service assemblies have reference numbers in the form a:b. The a represents the reference number of the entire service assembly and the b represents a sequential number unique to each part within the service assembly.

For example, a wheel assembly might be identified by reference number 6, the tire by 6:1, the valve by 6:2, and the wheel by 6:3. When you order the assembly identified by reference number 6, you receive all parts identified by reference numbers 6:1, 6:2, and 6:3. However, you may also order any part individually. Reference numbers of this type appear in illustration and in parts lists.

Reference Numbers Indicating Quantity

In an illustration, if a reference number indicates more than one part, the reference number has the form nX y. The n represents the quantity of the part, the X is the multiplication symbol, and the y represents the reference number.

For example, in an illustration, the reference number 2X 37 means that two of the parts identified by reference number 37 are indicated.

List of Abbreviations

AR: as required

ASM: assembly

BBC: blade brake control

BHTF: button head thread forming

CARR: carriage

CCW: counter clockwise

CW: clockwise

DEG: degrees

DPA: Dual Point Adjustment

ECM: electronic control module

EXT: external

FH: flat head

GA: gauge

HD: heavy-duty

HF: hex flange

HH: hex head

HHF: hex head flange

HHFTF: hex head flange thread forming

HJ: hex jam

HLH: hex lag head

HOC: height-of-cut

HSBH: hex socket button head

HSFH: hex socket flat head

HSH: hex socket head

HWH: hex washer head

HWHTF: hex washer head thread forming

HYD: hydraulic

LH: left hand

LP: Liquefied Petroleum Gas

LPG: Liquefied Petroleum Gas

NI: nylon insert

NPTF: national pipe thread fine

PFH: phillips flat head

PPH: phillips pan head

PPHTF: phillips pan head thread forming

PRH: phillips round head

PTH: phillips truss head

PTO: power-take-off

RH: right hand

ROPS: roll-over protection system

RRB: rear roller brush

SFH: slotted fillister head

SHH: slotted hex head

SHWH: slotted hex washer head

SPH: slotted pan head

SQH: square head

SRH: slotted round head

STD: standard

TAP: self tapping

TTH: torx truss head

Contents

Engine Assembly	4
Front Axle Assembly	6
Steering Control Assembly	8
Transmission Drive Assembly	10
Main Housing Transmission Assembly No. 121-0999	12
Center Section and Fan Pulley Assembly Transmission Assembly No. 121-0999	14
Side Housing Transmission Assembly No. 121-0999	16
Frame Assembly	18
Mower Lift Assembly	20
92cm Deck Assembly	22
Operation-Travel Pedal Assembly	24
Operation-Brake Assembly	26
Electrical-Wiring Harness Assembly	28
Seat and Body Fender Assembly	30
Hood and Control Panel Assembly	32
Grass Collector Assembly	34
Tunnel Assembly	36
Mulch Plug Assembly	38
Attachments and Accessories	40

Engine Assembly

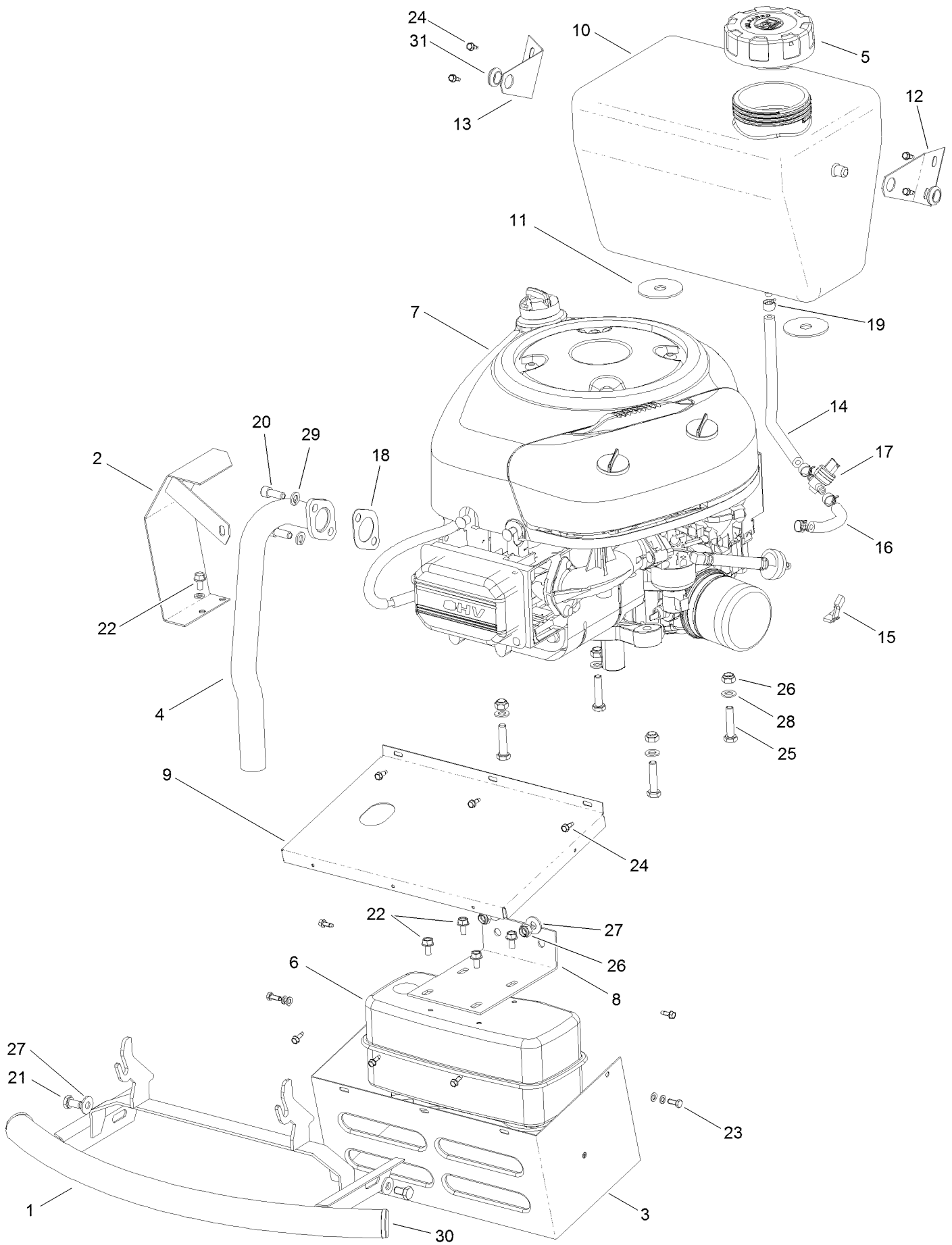

Engine Assembly (continued)

<i>Ref.</i>	<i>Part Number</i>	<i>Qty.</i>	<i>Description</i>	<i>Ref.</i>	<i>Part Number</i>	<i>Qty.</i>	<i>Description</i>
1	119-5350	1	Bumper	16	104-3213	1	Line-Fuel
2	119-5351	1	Shield-Exhaust Tube	17	104-3224	1	Valve-Tank, Fuel
3	119-5352	1	Shield-Muffler	18	119-5362	1	Gasket
4	119-5353	1	Tube-Exhaust	19	104-3212	4	Clamp-Line, Fuel
5	119-5354	1	Cap-Fuel	20	322-3	2	Screw-HH
6	104-3229	1	Muffler	21	33114-016	2	Screw-HH
7		1	Engine-Briggs, 21R877-0019-B1 ●	22	110-7170	5	Screw-HH
8	120-8711	1	Bracket-Muffler Mount	23	104-2980	5	Screw
9	119-5357	1	Cover-Top	24	104-2977	7	Screw-TAP
10	119-5358	1	Tank-Fuel	25	48-7740	6	Screw
11	119-5500	2	Washer-Rubber	26	33024-00	6	Nut-Lock, NI
12	119-5359	1	Bracket-Fuel Tank, Left	27	104-2946	4	Washer-Plain
13	119-5360	1	Bracket-Fuel Tank, Right	28	106-4756	7	Washer-Plain
14	119-5361	1	Hose-Fuel	29	104-2927	2	Washer-Spring
15	88-4490	1	Reducer-Throttle, Rpm	30	119-5363	2	Cap-Bumper
				31	119-5364	2	Bushing

● Not serviced separately

Front Axle Assembly

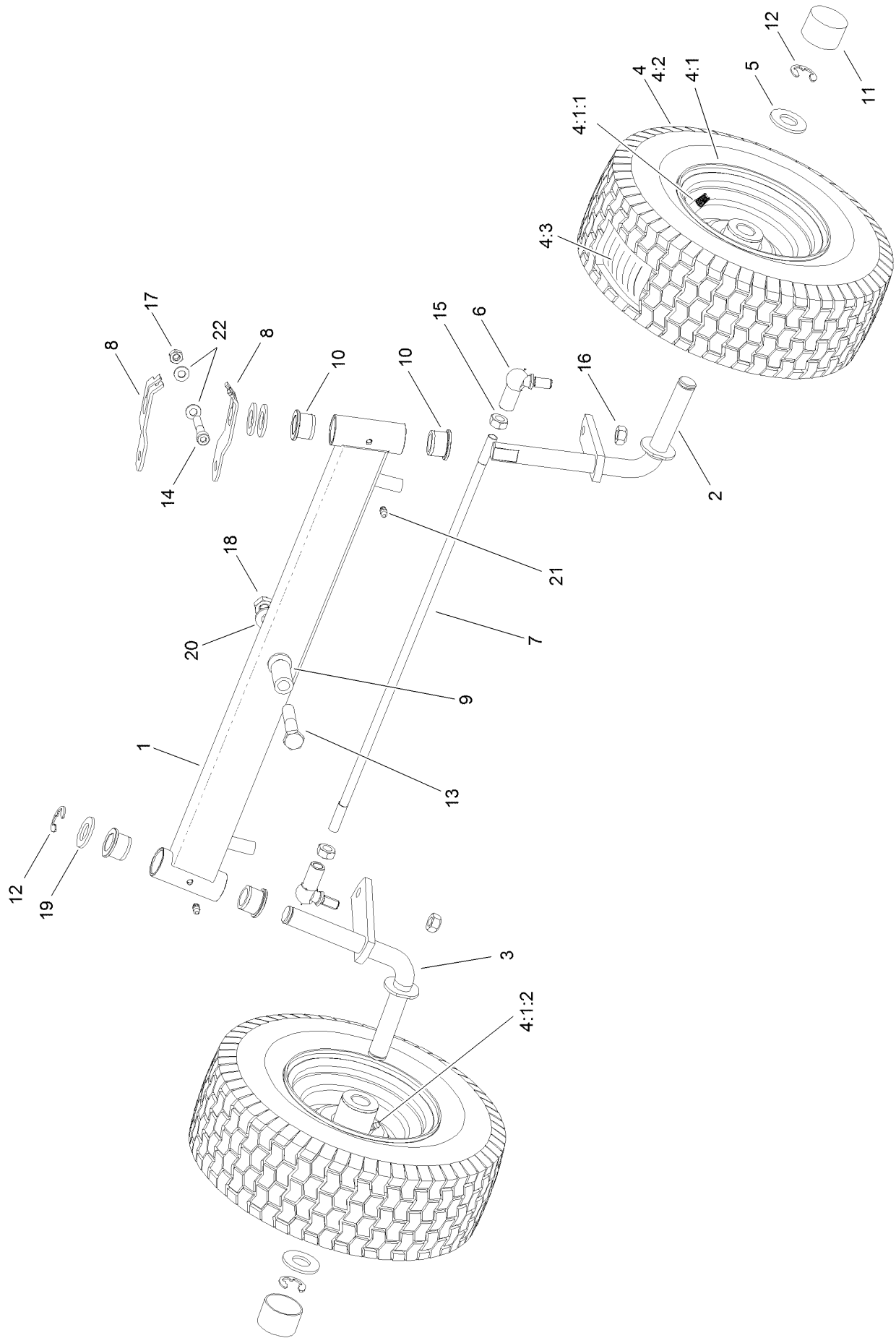

Front Axle Assembly (continued)

<i>Ref.</i>	<i>Part Number</i>	<i>Qty.</i>	<i>Description</i>	<i>Ref.</i>	<i>Part Number</i>	<i>Qty.</i>	<i>Description</i>
1	119-5365	1	Front Axle ASM	10	119-5371	4	Bushing-Swivel
2	120-8712	1	Spindle-LH	11	104-2857	2	Cap-Hub
3	119-5367	1	Spindle-RH	12	104-2891	3	Clip-Spring
4		2	Wheel ASM ●	13	33116-060	1	Screw-HH
4:1	119-5521	1	Front Rim ASM	14	120-8774	1	Screw
4:1:1	106-8596	1	Valve-Tire	15	33015-00	2	Nut-Hex
4:1:2	104-2904	1	Fitting-Grease	16	33025-00	2	Nut-Lock, NI
4:2	119-5522	1	Tire	17	33024-00	1	Nut-Lock, NI
4:3	232-38	1	Tube	18	48-9540	1	Nut-Lock, Hex NI
5	120-8739	2	Washer	19	104-2905	3	Washer-Flat
6	104-2876	2	Joint-Ball, Angle	20	119-5372	2	Washer
7	119-5369	1	Tie Rod-Axle, Front	21	104-2904	2	Fitting-Grease
8	120-8713	2	Lever-Spindle, Steering	22	106-4756	1	Washer-Plain
9	119-5370	1	Spacer				

● Not serviced separately

Steering Control Assembly

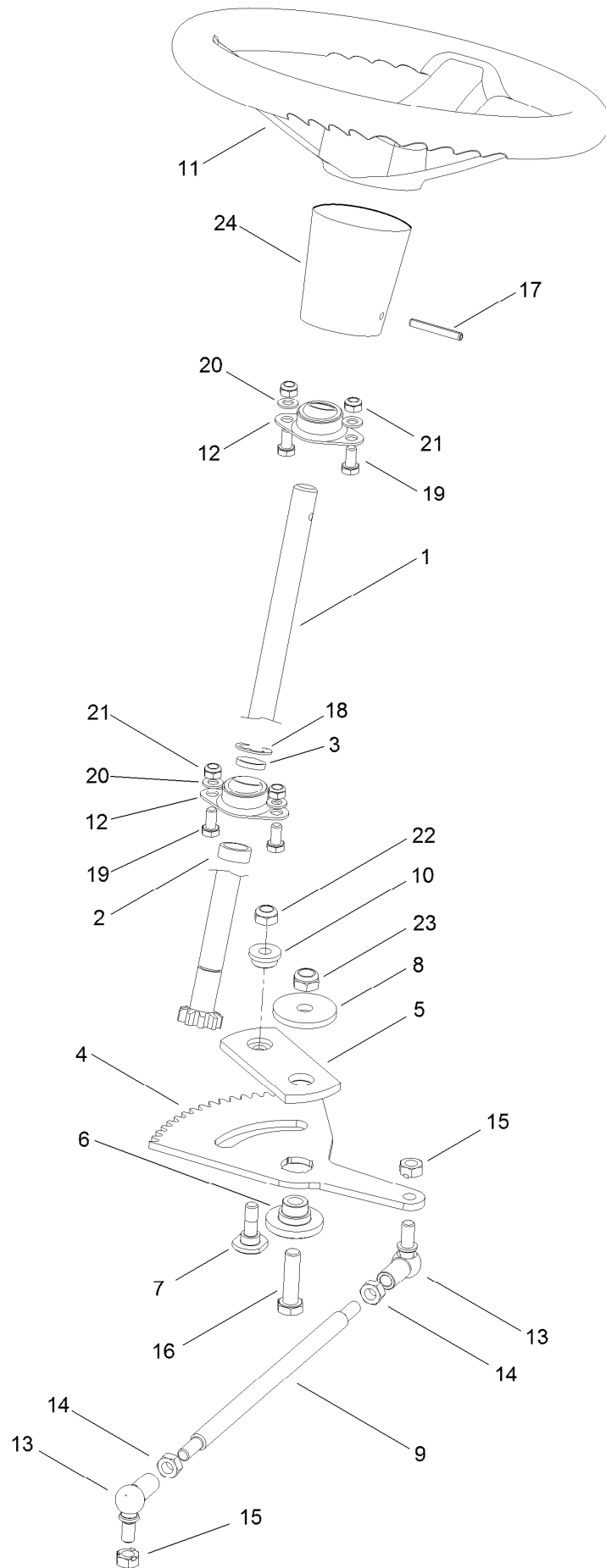

Steering Control Assembly (continued)

<i>Ref.</i>	<i>Part Number</i>	<i>Qty.</i>	<i>Description</i>	<i>Ref.</i>	<i>Part Number</i>	<i>Qty.</i>	<i>Description</i>
1	119-5373	1	Shaft-Steering	13	104-2876	2	Joint-Ball, Angle
2	104-2879	1	Spacer-Lower	14	33015-00	2	Nut-Hex
3	104-2877	1	Spacer-Upper	15	33025-00	2	Nut-Lock, NI
4	119-5374	1	Gear-Sector	16	104-2910	1	Screw-HH
5	105-1238	1	Plate-Steering	17	119-5377	1	Pin-Spirol
6	105-1240	1	Pivot-Steering	18	104-2891	1	Clip-Spring
7	105-1239	1	Bolt-Shoulder	19	33114-016	4	Screw-HH
8	108-8892	1	Washer	20	106-4756	4	Washer-Plain
9	119-5375	1	Link-Drag	21	33024-00	4	Nut-Lock, NI
10	105-1241	1	Bushing	22	33023-00	1	Nut-Lock
11	125-2237	1	Wheel-Steering	23	33016-00	1	Nut-Hex
12	104-2878	2	Bearing-Spherical	24	125-2238	1	Cover

Transmission Drive Assembly

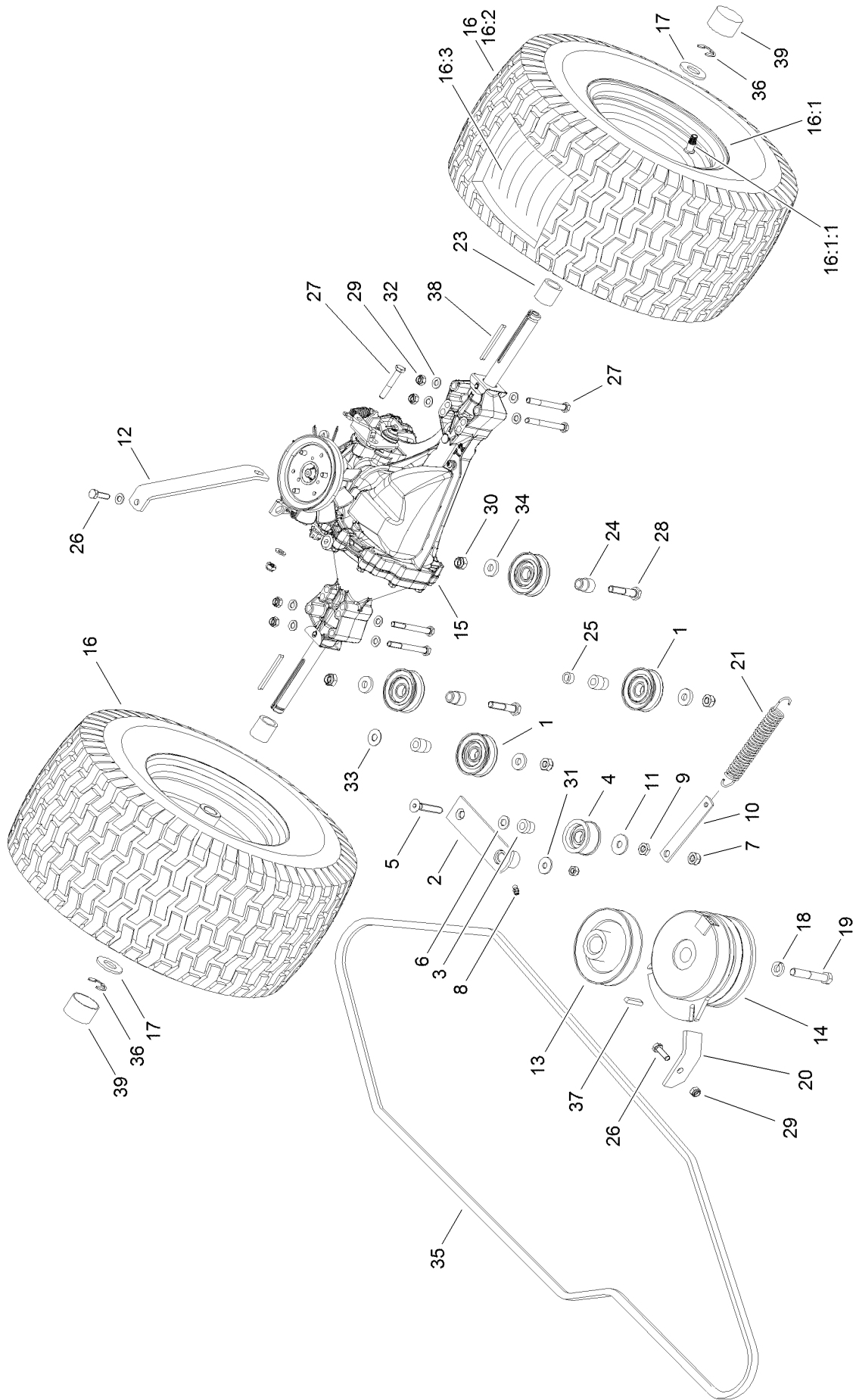

Transmission Drive Assembly (continued)

<i>Ref.</i>	<i>Part Number</i>	<i>Qty.</i>	<i>Description</i>	<i>Ref.</i>	<i>Part Number</i>	<i>Qty.</i>	<i>Description</i>
1	119-5378	4	Pulley-Idler	18	93-9043	1	Washer-Spring, Belleville
2	119-5379	1	Arm-Idler	19	3212-10	1	Screw-HH
3	104-2896	1	Bushing-Idler	20	119-5502	1	Bracket-Retainer
4	119-5380	1	Pulley-Idler	21	104-2897	1	Spring
5	119-5381	1	Screw	23	120-8715	2	Spacer-Axle
6	33095-00	1	Washer-Flat	24	119-5388	4	Bushing
7	33023-00	1	Nut-Lock	25	119-5389	1	Spacer
8	104-2904	1	Fitting-Grease	26	33114-020	3	Screw-HH
9	33035-00	1	Nut-Hex	27	60-6690	5	Capscrew
10	119-5382	1	Bracket-Tention	28	117-5664	2	Screw-HH
11	119-5383	1	Washer	29	33024-00	9	Nut-Lock, NI
12	119-5384	1	Bracket	30	33023-00	4	Nut-Lock
13	119-5385	1	Pulley-Engine	31	104-2946	1	Washer-Plain
14	119-5501	1	Clutch-Electric	32	106-4756	11	Washer-Plain
15	121-0999	1	Transmission ASM	33	106-5768	1	Washer
16		2	Wheel ASM ●	34	108-8709	4	Washer-Flat
16:1	119-5523	1	Rim-Rear	35	119-5390	1	V-Belt, Traction
16:1:1	106-8596	1	Valve-Tire	36	104-2891	2	Clip-Spring
16:2	119-5524	1	Tire	37	104-2899	1	Key-Square
16:3	232-41	1	Tube	38	104-2892	2	Key-Square
17	120-8739	2	Washer	39	104-2857	2	Cap-Hub

● Not serviced separately

Main Housing Transmission Assembly No. 121-0999

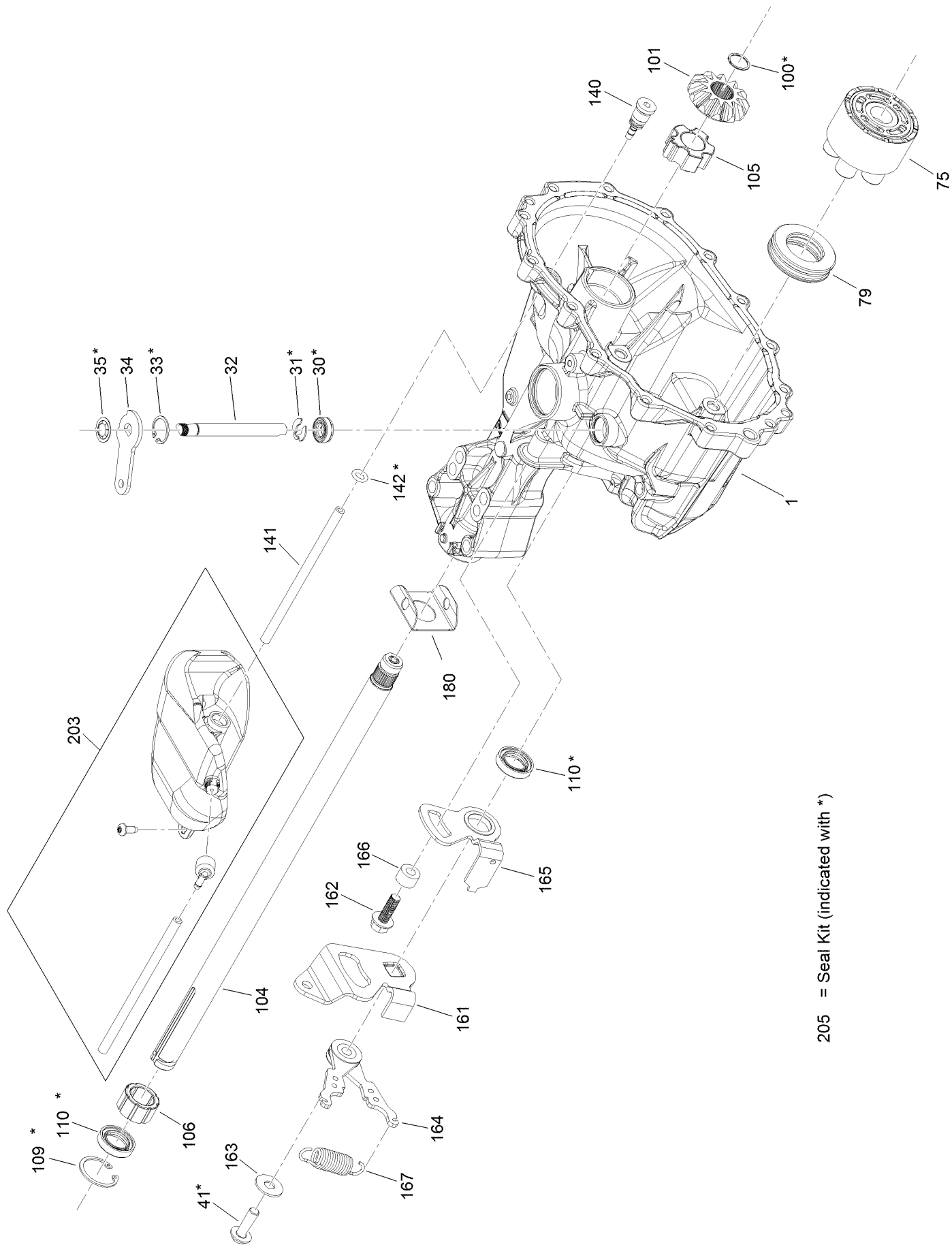

205 = Seal Kit (indicated with *)

Main Housing Transmission Assembly No. 121-0999 (continued)

<i>Ref.</i>	<i>Part Number</i>	<i>Qty.</i>	<i>Description</i>	<i>Ref.</i>	<i>Part Number</i>	<i>Qty.</i>	<i>Description</i>
1	115-8313	1	Main Housing Kit	106	115-8304	1	Bushing-Outboard
10	104-2147	1	Sealant ●	109	115-8303	1	Ring-Retaining, Int
11	104-5342	1	Oil, 20W-50 ●	110	121-0970	2	Seal-Lip
30	106-8676	1	Seal-Lip	140	104-5349	1	Fitting-Sae
31	106-8677	1	Ring-Retaining, EXT	141	115-8302	1	Hose
32	115-8312	1	Rod-Bypass, Actuator	142	104-5361	1	O-Ring
33	106-8679	1	Ring-Retaining, Int	161	115-8308	1	Arm-Control, Return
34	115-8311	1	Arm-Bypass	162	104-5312	1	Screw-HF
35	106-8681	1	Ring-Retaining, EXT	163	114-8491	1	Washer
41	107-2488	1	Screw	164	115-8306	1	Bi Directional Return Kit
75	103-2666	1	Cylinder Block Kit	165	115-8310	1	Arm-Neutral
79	94-6922	1	Bearing-Thrust	166	115-8309	1	Bushing
100	104-5328	1	Ring-Retaining, Spiral	167	115-8307	1	Spring-Extension
101	115-8315	1	Gear-Bevel, 12T (Spline, Id)	180	119-5527	1	Spring Clip-Housing Thrust
104	121-0969	1	Shaft-Axle, Keyed	203	115-8301	1	Expansion Tank Kit
105	115-8314	1	Bushing-Inboard	205	115-8316	1	Seal Kit ●

● Not illustrated

Center Section and Fan Pulley Assembly Transmission Assembly No. 121-0999

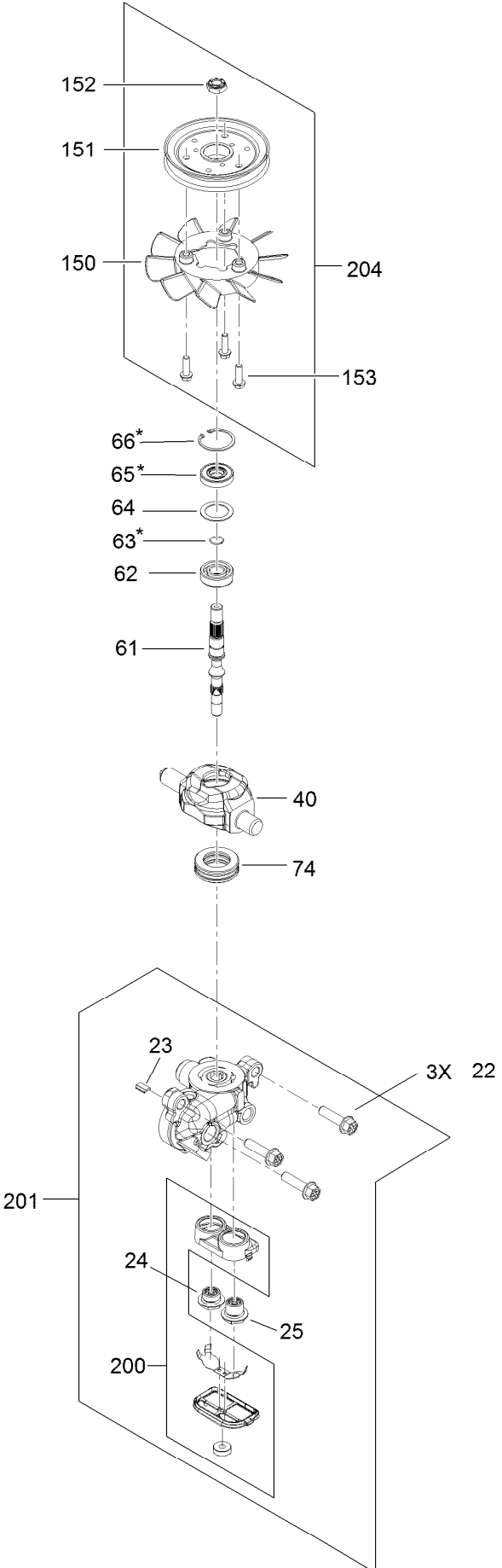

Main Seal Kit items are indicated with *

Center Section and Fan Pulley Assembly Transmission Assembly No. 121-0999 (continued)

<i>Ref.</i>	<i>Part Number</i>	<i>Qty.</i>	<i>Description</i>	<i>Ref.</i>	<i>Part Number</i>	<i>Qty.</i>	<i>Description</i>
22	114-1684	3	Screw-Hfhc	66	119-5533	1	Ring-Retaining
23	119-5528	1	Plate-Bypass	70	121-0967	1	Piston Block ASM ●
24	104-5348	1	Check Plug ASM	74	115-8320	1	Bearing-Thrust, Ball
25	119-5529	1	Check Plug ASM	150	105-1927	1	Fan
40	115-8319	1	Trunnion-Plate, Swash	151	119-5534	1	Pulley ASM
61	115-8317	1	Shaft-Input	152	121-0971	1	Nut-Hex Jam
62	119-5530	1	Bearing-Ball	153	105-1897	3	Screw
63	119-5531	1	Ring-Retaining, Wire	200	115-8323	1	Filter Kit
64	104-2104	1	Spacer	201	121-0972	1	Center Section Kit
65	119-5532	1	Seal-Lip	204	119-5537	1	Fan Pulley Kit

● Not illustrated

Side Housing Transmission Assembly No. 121-0999

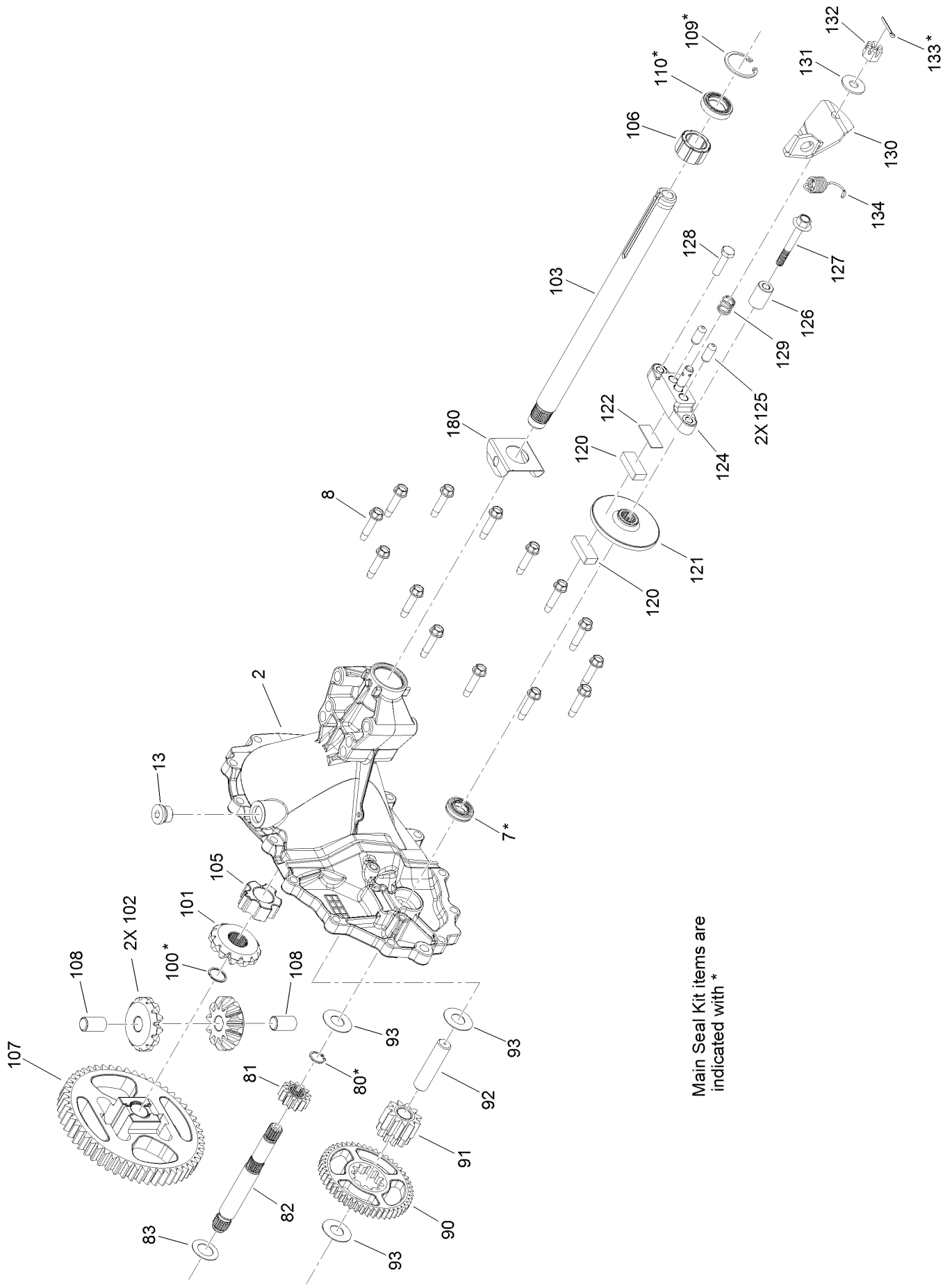

Side Housing Transmission Assembly No. 121-0999 (continued)

<i>Ref.</i>	<i>Part Number</i>	<i>Qty.</i>	<i>Description</i>	<i>Ref.</i>	<i>Part Number</i>	<i>Qty.</i>	<i>Description</i>
2	119-5538	1	Housing Side Kit	108	115-8326	2	Pin-Differential
7	115-8335	1	Seal-Lip	109	115-8303	1	Ring-Retaining, Int
8	117-5359	14	Screw-HHF	110	119-5526	1	Seal-Lip
13	104-2189	1	Plug-Thread, Straight	120	104-2171	2	Puck-Brake
80	115-8331	1	Ring-Retaining, EXT	121	115-8337	1	Rotor-Brake
81	119-5539	1	Gear-Pinion	122	104-2181	1	Puck-Plate
82	115-8329	1	Shaft-Motor	124	104-5343	1	Yoke-Brake
83	115-8328	1	Washer	125	104-2176	2	Pin-Brake
90	119-5540	1	Gear	126	104-2180	1	Spacer
91	115-8333	1	Gear-Jackshaft, 11T	127	104-5345	1	Screw-HF
92	115-8334	1	Pin-Jackshaft	128	115-8339	1	Screw-Hhcs
93	119-5541	3	Washer	129	104-2188	1	Spring-Brake, Anti Drag
100	104-5328	1	Ring-Retaining, Spiral	130	119-5542	1	Arm-Brake
101	115-8315	1	Gear-Bevel, 12T (Spline, Id)	131	114-8491	1	Washer
102	115-8327	2	Gear-Bevel, 12T (.50 Id)	132	119-5543	1	Nut-Castle
103	121-0968	1	Shaft-Axle, Keyed	133	3272-7	1	Pin-Cotter
105	115-8314	1	Bushing-Inboard	134	115-8338	1	Spring-Brake, Arm
106	115-8304	1	Bushing-Outboard	180	119-5527	1	Spring Clip-Housing Thrust
107	115-8325	1	Gear-53T, Bull				

Frame Assembly

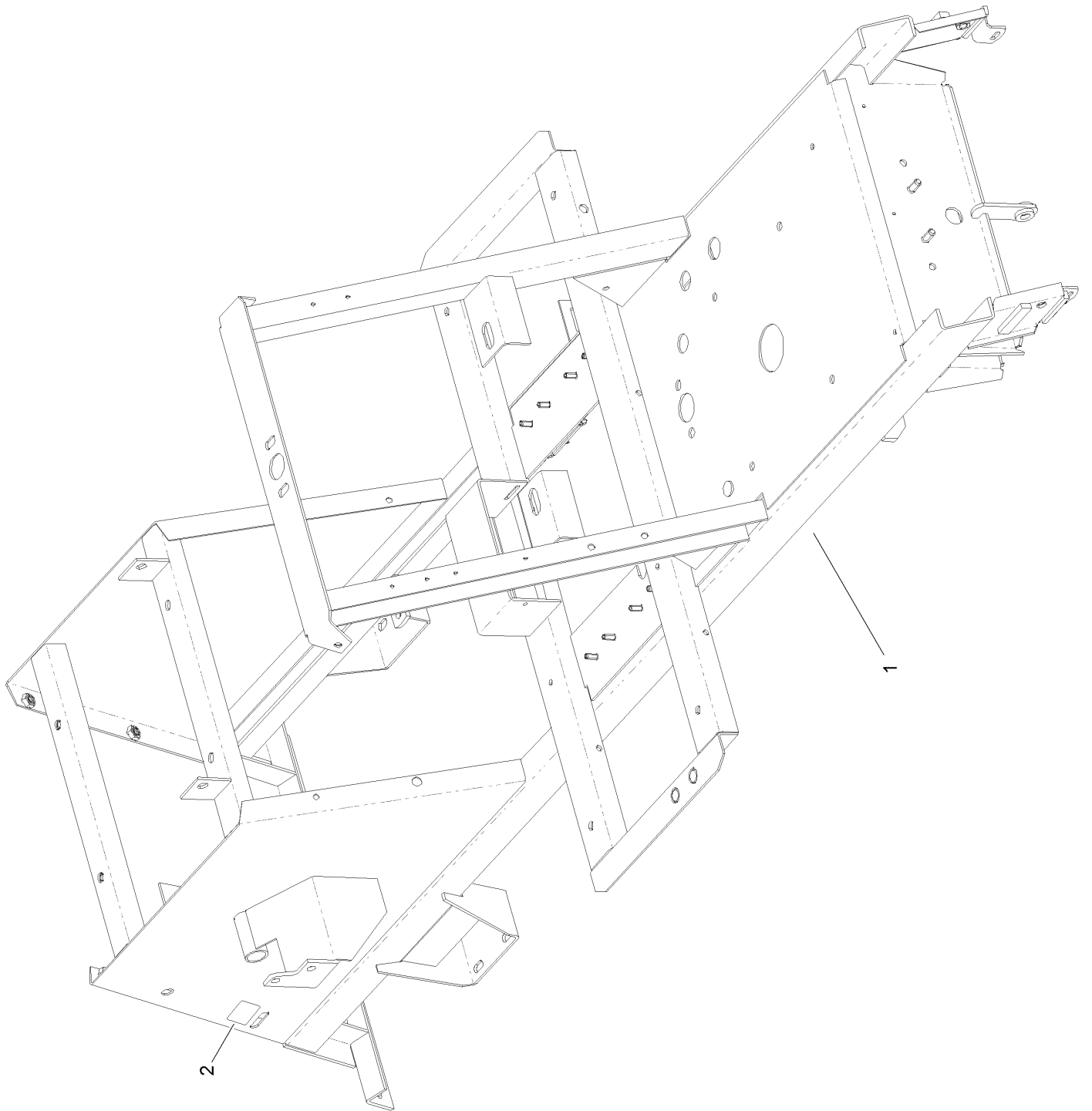

Frame Assembly (continued)

<i>Ref.</i>	<i>Part Number</i>	<i>Qty.</i>	<i>Description</i>
1	120-8710	1	Frame-Complete
2	119-5515	1	Decal-Bypass

Mower Lift Assembly

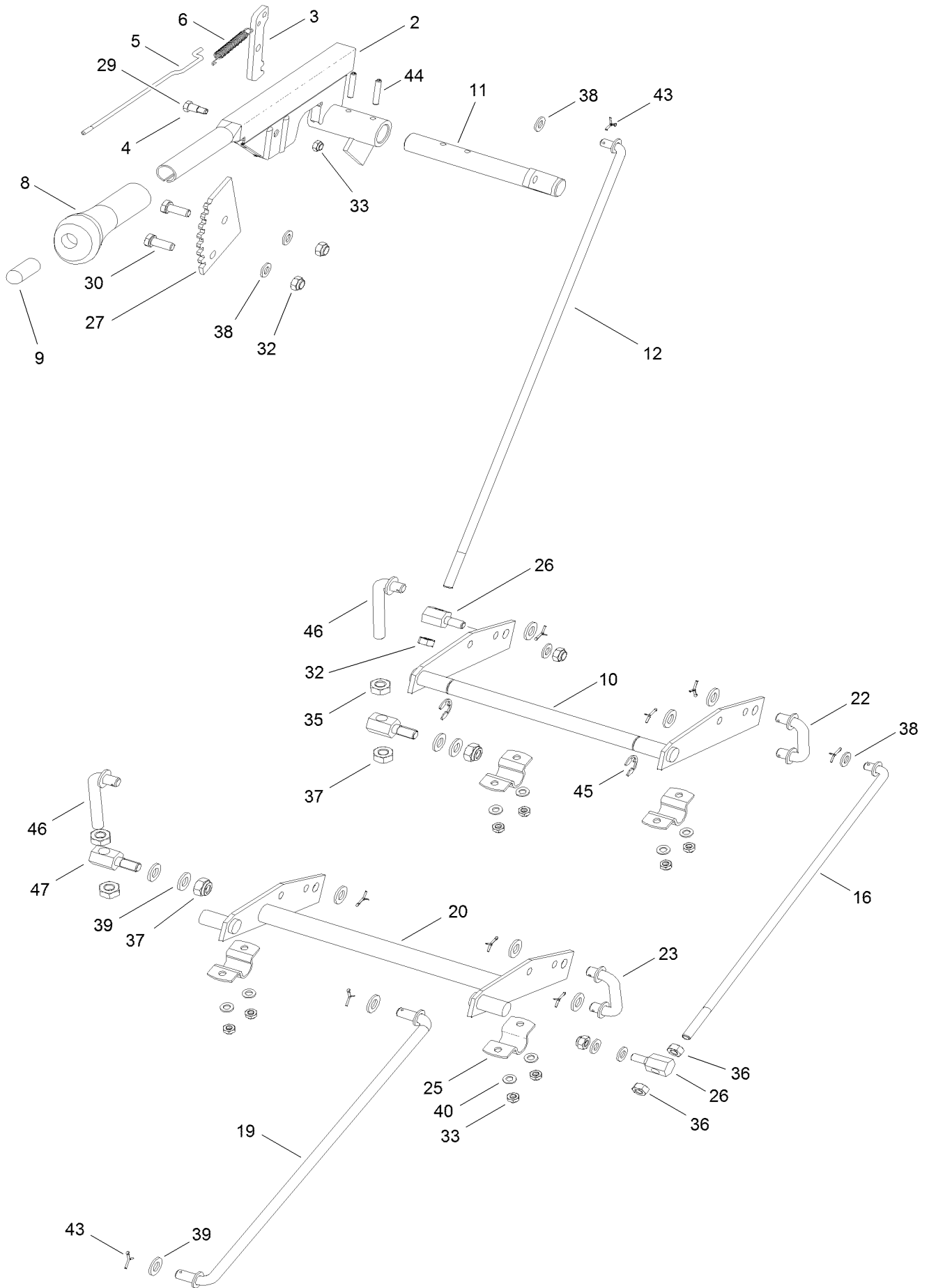

Mower Lift Assembly (continued)

<i>Ref.</i>	<i>Part Number</i>	<i>Qty.</i>	<i>Description</i>	<i>Ref.</i>	<i>Part Number</i>	<i>Qty.</i>	<i>Description</i>
2	120-8716	1	Lever-Arm	27	114-3244	1	Gear-Segment, Lift (Deck)
3	104-3130	1	Ratchet-Plate, Pivot	29	33113-016	1	Screw-HH
4	120-8754	1	Bushing	30	33114-020	2	Screw-HH
5	104-3132	1	Rod-Connection	32	33024-00	4	Nut-Lock, NI
6	104-3134	1	Spring	33	33023-00	9	Nut-Lock
8	104-3129	1	Grip-Handle	35	33015-00	2	Nut-Hex
9	104-3131	1	Button-Plunger	36	33014-00	4	Nut-Hex
10	120-8717	1	Hanger-Rear	37	33025-00	4	Nut-Lock, NI
11	120-8718	1	Shaft-Adjustment, Height	38	106-4756	7	Washer-Plain
12	120-8719	1	Rod	39	104-2906	10	Washer-Flat
16	119-5397	1	Rod-Linkage	40	104-3193	8	Washer
19	120-8720	1	Rod	43	104-3151	9	Pin-Cotter
20	119-5401	1	Hanger-Front	44	104-2994	2	Pin-Spring
22	119-5403	1	Link-Deck, U-Shape	45	119-5503	2	E-Clip
23	119-5404	1	Link-Deck, U-Shape	46	119-5544	2	Link-Deck, L-Shape (Adjustable)
25	119-5406	4	Clamp	47	119-5545	2	Trunion
26	119-5407	1	Trunion				

92cm Deck Assembly

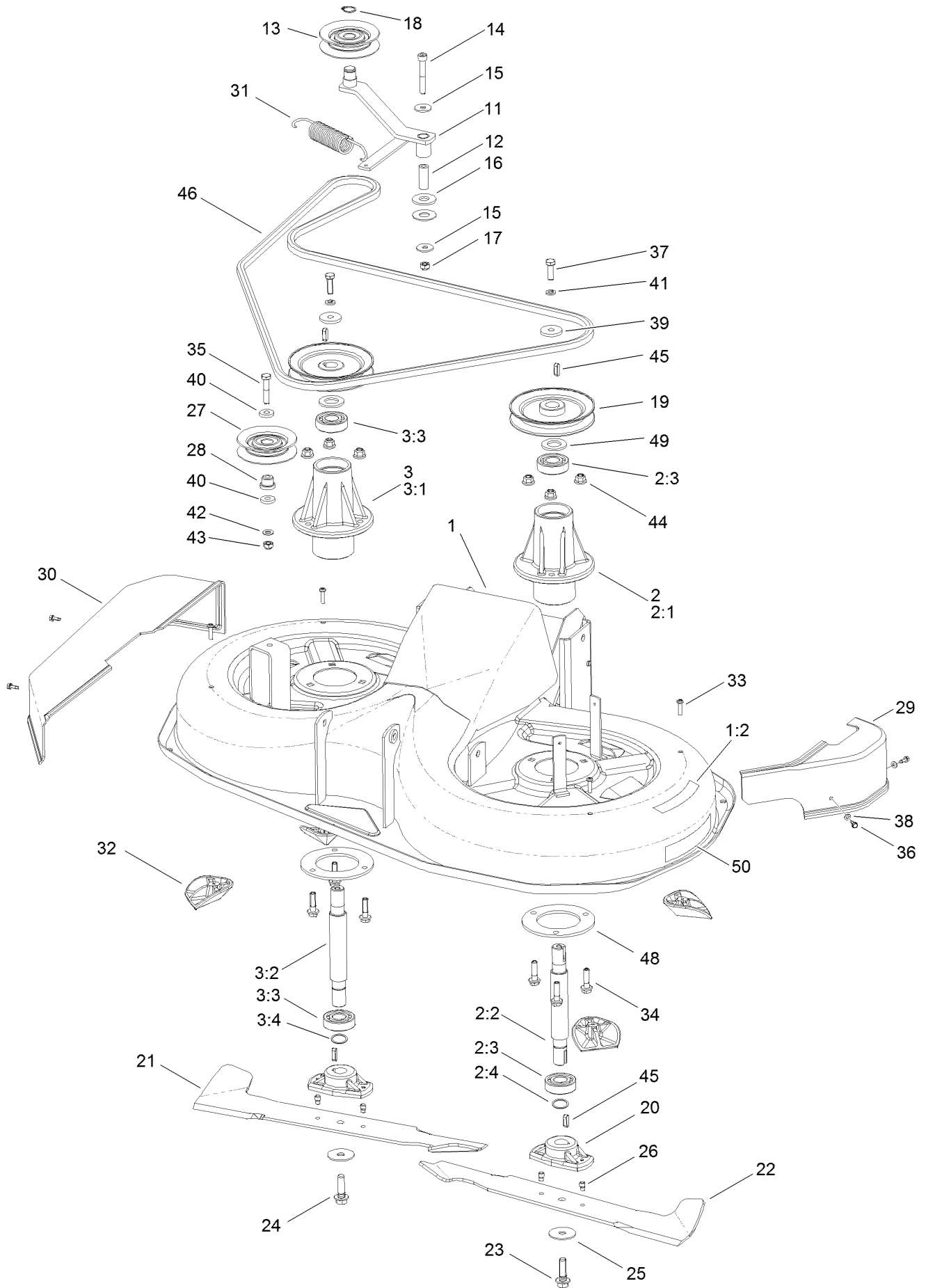

92cm Deck Assembly (continued)

<i>Ref.</i>	<i>Part Number</i>	<i>Qty.</i>	<i>Description</i>	<i>Ref.</i>	<i>Part Number</i>	<i>Qty.</i>	<i>Description</i>
1	119-5508	1	Deck ASM	25	104-3092	2	Washer-Belleville
1:2	119-2726	2	Decal-Danger	26	104-3093	4	Pin-Shear, Grooved
2	119-5425	1	Left Spindle ASM	27	119-5414	1	Pulley-Idler
2:1	119-5426	1	Housing-Spindle	28	104-3104	1	Bushing
2:2	119-5409	1	Shaft-Blade, Left	29	119-5419	1	Guard-Belt, Left
2:3	119-5505	2	Bearing	30	119-5420	1	Guard-Belt, Right
2:4	119-5410	1	Ring-Lock	31	119-5421	1	Spring
3	119-5427	1	Right Spindle ASM	32	119-0369	4	Kicker
3:1	119-5426	1	Housing-Spindle	33	119-5423	4	Screw
3:2	119-5411	1	Shaft-Blade, Right	34	33104-030	6	Screw-HHF
3:3	119-5505	2	Bearing	35	33114-040	1	Screw-HH
3:4	119-5410	1	Ring-Lock	36	104-3190	4	Screw
11	119-5412	1	Arm-Idler	37	33114-025	2	Screw-HH
12	119-5547	1	Spacer	38	104-2984	4	Washer
13	119-5414	1	Pulley-Idler	39	119-5507	2	Washer
14	60-6700	1	Bolt-HH	40	106-8588	2	Washer-Flat
15	104-2946	2	Washer-Plain	41	104-2927	2	Washer-Spring
16	119-5548	1	Washer-Plain	42	106-4756	1	Washer-Plain
17	33024-00	1	Nut-Lock, NI	43	33024-00	1	Nut-Lock, NI
18	119-5525	1	Ring-Lock	44	104-3082	6	Nut-Lock, HHF
19	119-5416	2	Pulley-Belt, Mowing	45	119-2424	4	Key
20	119-5506	2	Adapter-Mount, Blade	46	119-2425	1	Belt-Wedge, Double
21	117-0035	1	Blade-RH	48	104-3084	2	Support-Ring
22	117-0036	1	Blade-LH	49	119-5549	2	Washer-Plain
23	104-3088	1	Screw-Hex	50	114-3255	1	Decal-Recycler
24	104-3091	1	Screw-HH, Left				

Operation-Travel Pedal Assembly

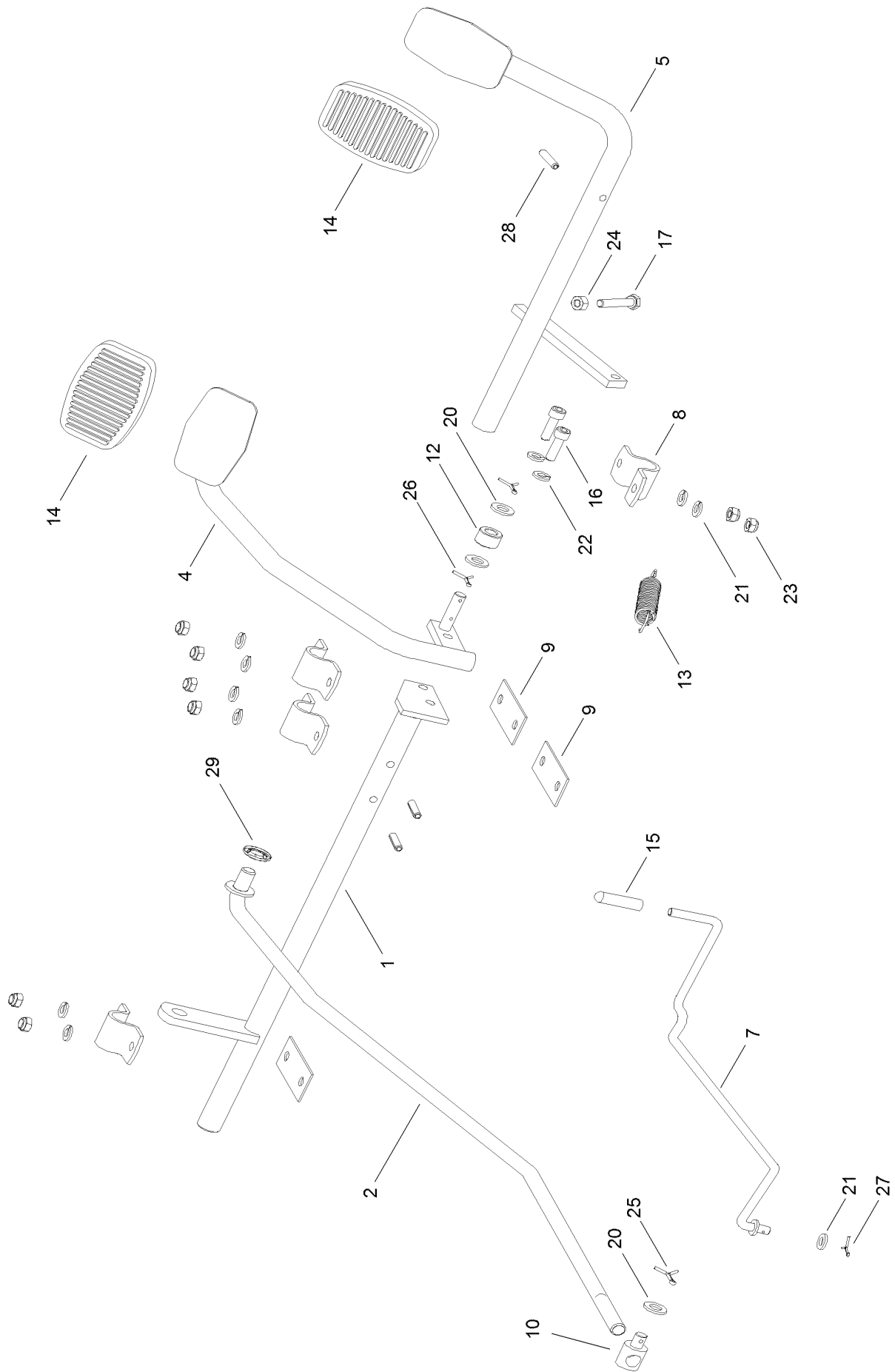

Operation-Travel Pedal Assembly (continued)

<i>Ref.</i>	<i>Part Number</i>	<i>Qty.</i>	<i>Description</i>	<i>Ref.</i>	<i>Part Number</i>	<i>Qty.</i>	<i>Description</i>
1	120-8721	1	Shaft-Pivot	16	120-8779	2	Screw
2	120-8722	1	Rod-Linkage	17	33113-030	1	Screw-HH
4	120-8723	1	Pedal-Travel, Forward	20	106-4756	3	Washer-Plain
5	120-8724	1	Pedal-Travel, Reverse	21	104-3193	3	Washer
7	119-2432	1	Rod-Lever, Bypass	22	104-3186	2	Washer-Spring
8	119-2433	3	Clamp	23	33023-00	8	Nut-Lock
9	119-2434	2	Spacer	24	104-2991	1	Nut-Hex
10	119-2435	1	Pin	25	104-3027	1	Pin-Cotter
12	106-8581	1	Roller	26	104-3151	2	Pin-Cotter
13	119-2436	1	Spring	27	104-2997	1	Pin-Cotter
14	104-3018	2	Pad-Pedal	28	104-3008	3	Pin-Spring
15	108-8708	1	Cap-Bypass Lever, Hydro	29	121-0962	1	Washer-M10

Operation-Brake Assembly

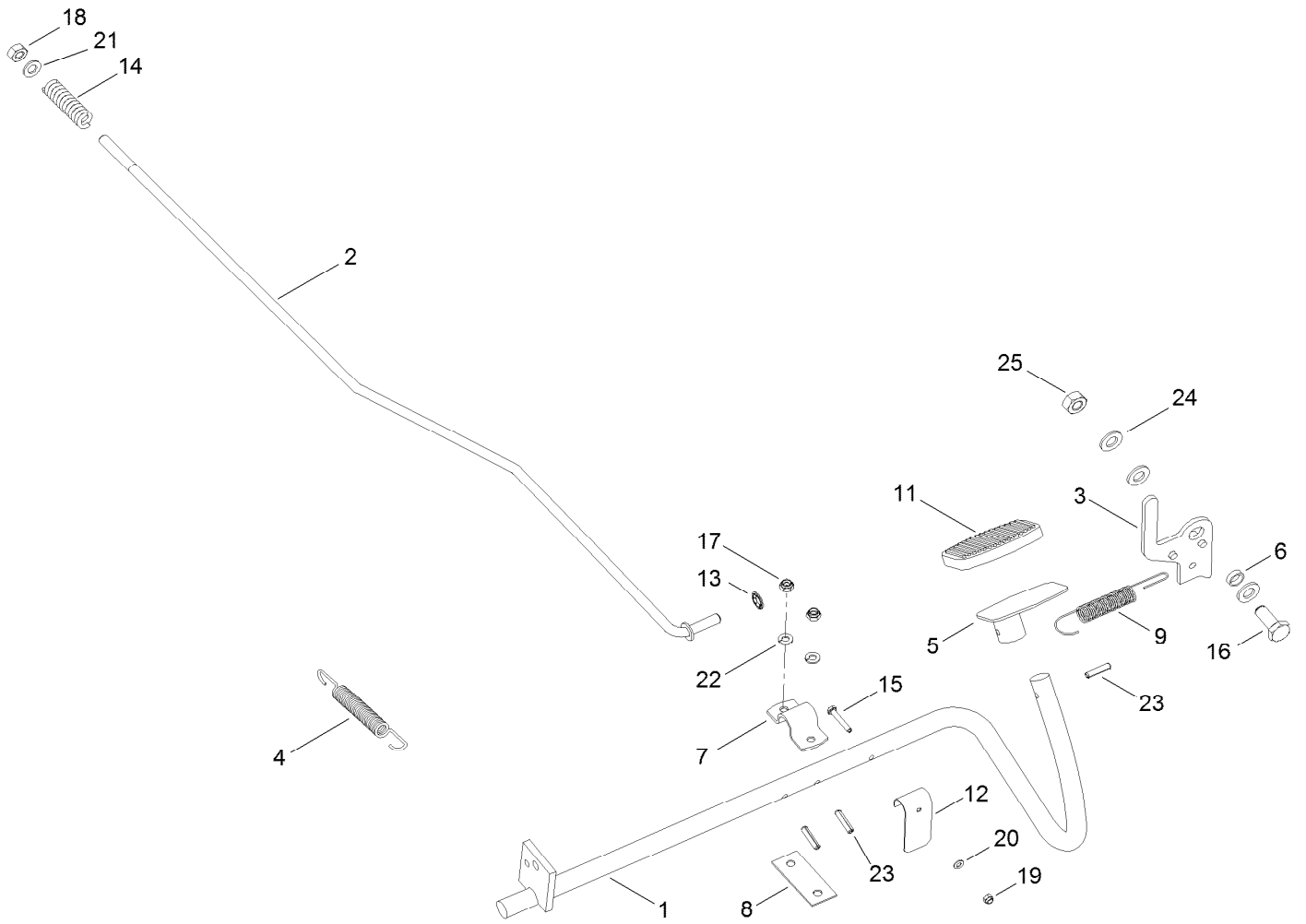

Operation-Brake Assembly (continued)

<i>Ref.</i>	<i>Part Number</i>	<i>Qty.</i>	<i>Description</i>	<i>Ref.</i>	<i>Part Number</i>	<i>Qty.</i>	<i>Description</i>
1	120-8763	1	Pedal	14	104-3002	1	Spring-Brake
2	120-8725	1	Rod-Brake, Linkage	15	104-3009	1	Screw-Hex
3	120-8726	1	Lever-Parking, Brake	16	104-3041	1	Screw-Hex
4	104-3001	1	Spring	17	33023-00	2	Nut-Lock
5	120-8727	1	Pedal-Travel, Brake	18	33024-00	1	Nut-Lock, NI
6	120-8728	1	Spacer	19	104-2985	1	Nut-Hex
7	119-5406	1	Clamp	20	106-5766	1	Washer
8	119-2434	1	Spacer	21	106-4756	2	Washer-Plain
9	104-3005	1	Spring-Brake, Hand	22	104-3193	2	Washer
11	104-3018	1	Pad-Pedal	23	104-3008	3	Pin-Spring
12	119-5509	1	Bracket-Parking Brake	24	33095-00	3	Washer-Flat
13	121-0963	1	Washer	25	33023-00	1	Nut-Lock

Electrical-Wiring Harness Assembly

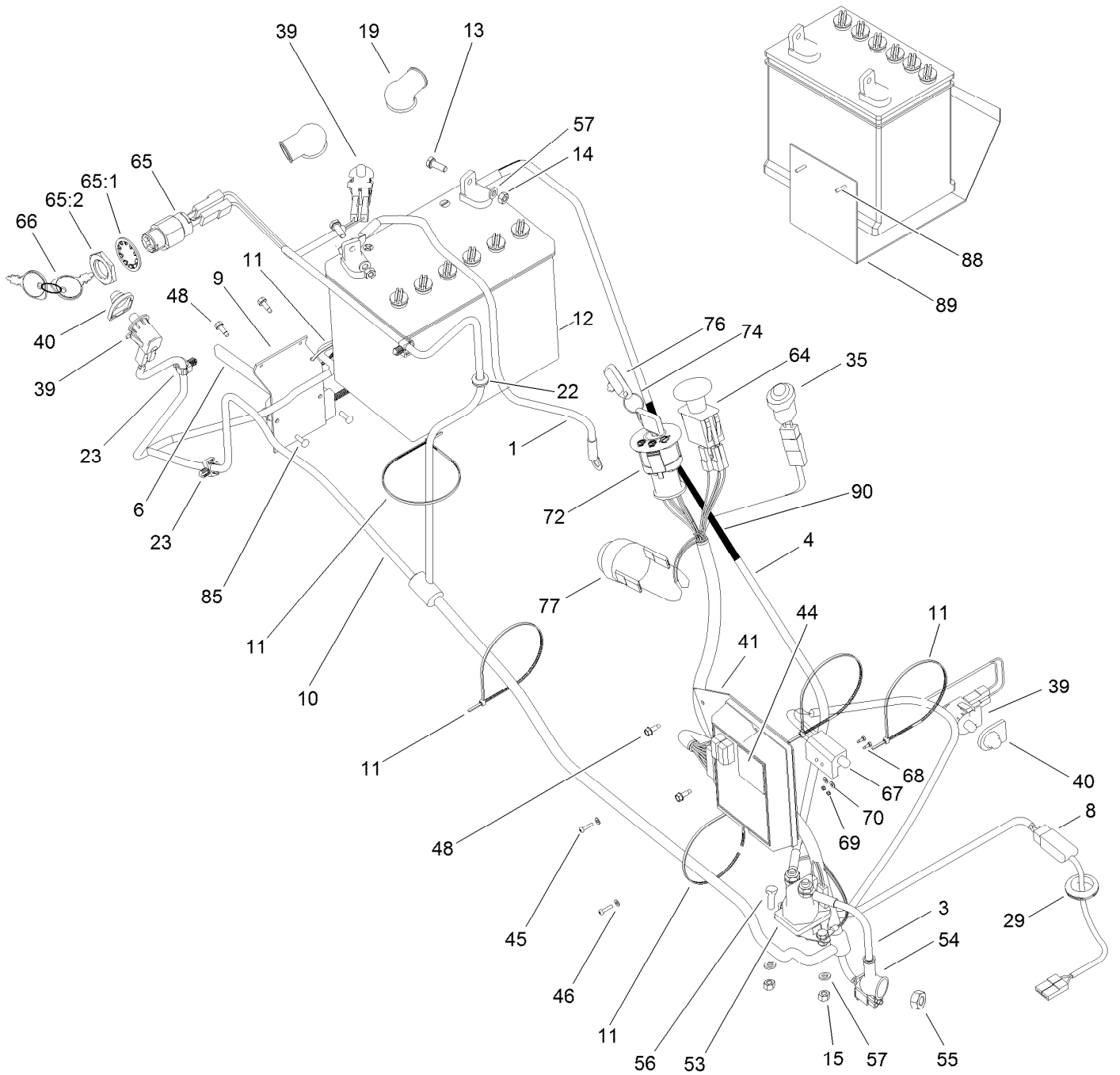

Electrical-Wiring Harness Assembly (continued)

<i>Ref.</i>	<i>Part Number</i>	<i>Qty.</i>	<i>Description</i>	<i>Ref.</i>	<i>Part Number</i>	<i>Qty.</i>	<i>Description</i>
1	119-5417	1	Cable-Battery, Negative	48	104-2977	4	Screw-TAP
3	119-5418	1	Lead-Starter, Electric	53	104-3189	1	Solenoid
4	120-8729	1	Cable-Battery, Positive	54	104-3187	1	Boot-Rubber
6	119-5429	1	Switch-Omron	55	32128-32	1	Nut-HHF
8	119-5430	1	Harness-Clutch	56	33113-012	2	Screw-HH
9	119-5431	1	Bracket-Switch	57	104-3193	4	Washer
10	119-5432	1	Harness-Wiring	64	93-9998	1	Switch-PTO
11	111-6843	5	Tie-Cable	65	46-5780	1	Starter Switch ASM
12	104-2491	1	Battery	65:1	3254-5	1	Washer-Tooth, Internal
13	33113-016	2	Screw-HH	65:2	218-461	1	Nut-HH
14	104-2991	2	Nut-Hex	66	62-7770	2	Key-Ignition
15	33023-00	2	Nut-Lock	67	119-5440	1	Switch-Delta
19	104-3154	2	Boot-Rubber	68	104-3331	2	Bolt
22	104-3164	1	Bushing	69	104-2985	1	Nut-Hex
23	104-3157	4	Clip-Snap	70	104-2984	1	Washer
29	104-2959	1	Bushing	72	119-5438	1	Switch-Ignition
35	119-5441	1	Lamp-Indicator	74	119-5439	1	Ring
39	104-3179	3	Switch-Delta	76	119-5510	2	Key-Ignition
40	104-3178	2	Cover-Protective	77	119-5511	1	Buzzer
41	119-5433	1	Bracket-Module, Support	85	104-3349	2	Screw
44	119-5434	1	Module-Control	88	106-5763	4	Screw
45	119-5436	2	Screw	89	125-2290	1	Holder-Battery
46	119-5437	2	Washer	90	111-6844	1	Protection-Cable

Seat and Body Fender Assembly

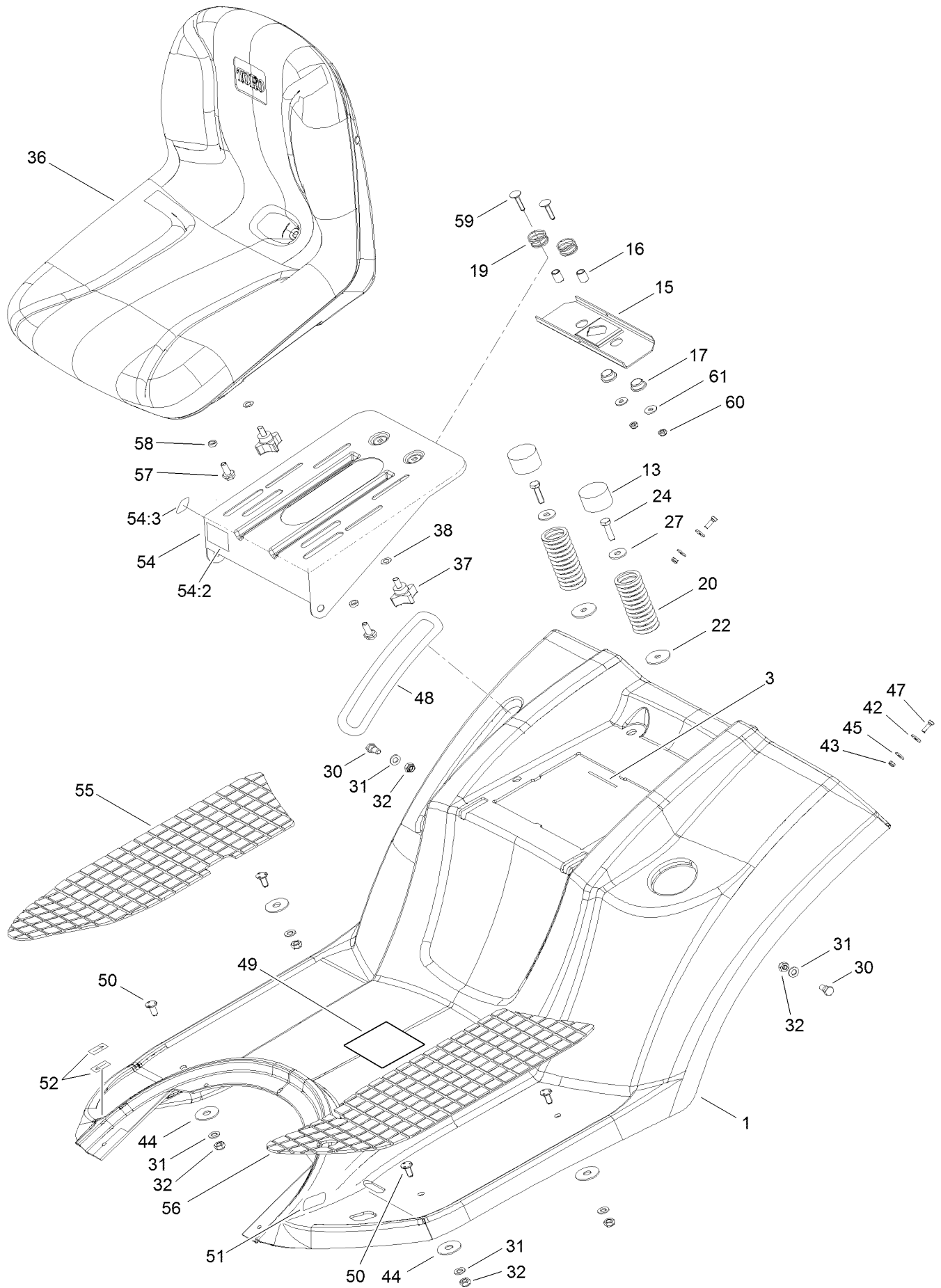

Seat and Body Fender Assembly (continued)

<i>Ref.</i>	<i>Part Number</i>	<i>Qty.</i>	<i>Description</i>	<i>Ref.</i>	<i>Part Number</i>	<i>Qty.</i>	<i>Description</i>
1	125-2306	1	Fender-Rear	44	104-2949	4	Washer-Rubber
3	111-6845	1	Rubber-Purl, Battery	45	104-2952	2	Washer-Rubber
13	104-2857	2	Cap-Hub	47	104-2980	2	Screw
15	104-2934	1	Bracket	48	120-8748	1	Decal-HOC
16	104-2933	2	Spacer-Split	49	119-2725	1	Decal-Danger, Tractor
17	104-2935	2	Bushing	50	100-8159	4	Screw-HSFH
19	119-5514	2	Seat-Spring	51	104-3237	1	Decal-Brake, Parking
20	104-2945	2	Spring-Seat	52	119-5487	2	Decal-Travel
22	120-8747	2	Washer	54	119-5513	1	Bracket-Support, Seat
24	33114-025	2	Screw-HH	54:2	119-2730	1	Decal-Danger
27	104-2946	2	Washer-Plain	54:3	99-5340	1	Decal-Switch
30	104-2939	2	Screw-Support, Seat	55	120-8745	1	Mat-Foot, RH
31	33094-00	6	Washer-Plain	56	120-8746	1	Mat-Foot, LH
32	33024-00	6	Nut-Lock, NI	57	33104-020	2	Screw-HHF
36	119-5455	1	Seat	58	119-5457	2	Spacer
37	119-5456	2	Knob-Adjust	59	33123-00	2	Screw
38	104-2936	2	Washer-Spring	60	33023-00	2	Nut-Lock
42	104-2943	2	Washer-Flat	61	104-2931	2	Washer-Flat
43	87-5140	2	Nut-Lock				

Hood and Control Panel Assembly

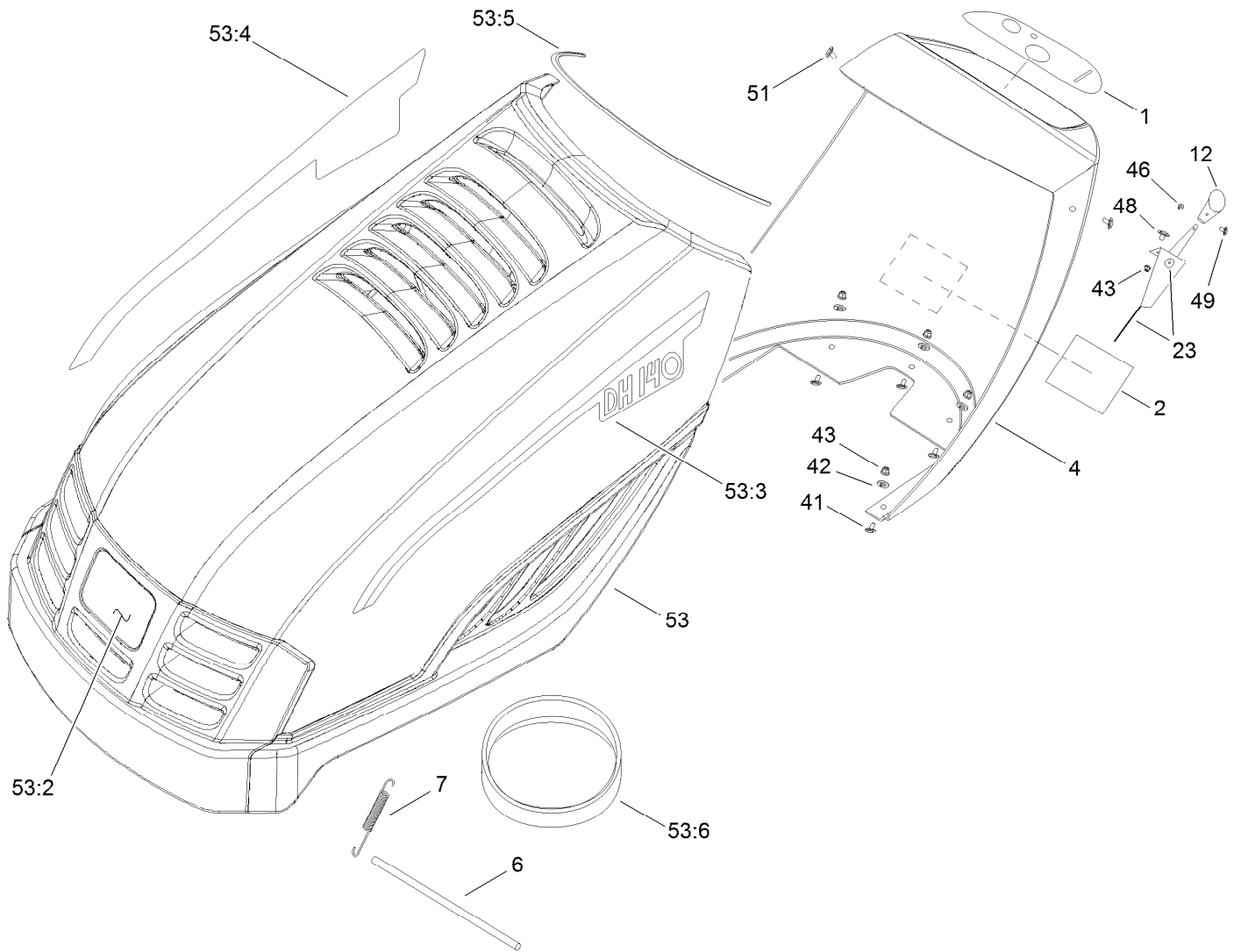

Hood and Control Panel Assembly (continued)

<i>Ref.</i>	<i>Part Number</i>	<i>Qty.</i>	<i>Description</i>	<i>Ref.</i>	<i>Part Number</i>	<i>Qty.</i>	<i>Description</i>
1	119-5486	1	Decal-Panel	46	104-2985	1	Nut-Hex
2	119-5517	1	Decal-Instructions, Operating	48	104-2966	2	Screw-Flat Head
4	119-5444	1	Panel-Dash	49	119-5458	1	Screw
6	104-2974	1	Bar-Safety	51	119-5460	2	Screw
7	104-2975	1	Spring-Hood	53	119-5520	1	Hood Assembly
12	119-5448	1	Knob-Throttle/Choke	53:2	117-0871	1	Decal
23	119-5453	1	Cable-Throttle/Choke	53:3	119-2718	1	Decal-Dh 140 (LH)
41	104-2978	5	Screw-Hex	53:4	119-2719	1	Decal-Dh 140 (RH)
42	104-2943	10	Washer-Flat	53:5	119-5445	1	Rubber-Purl
43	87-5140	7	Nut-Lock	53:6	119-5446	1	Gasket-Foam

Grass Collector Assembly

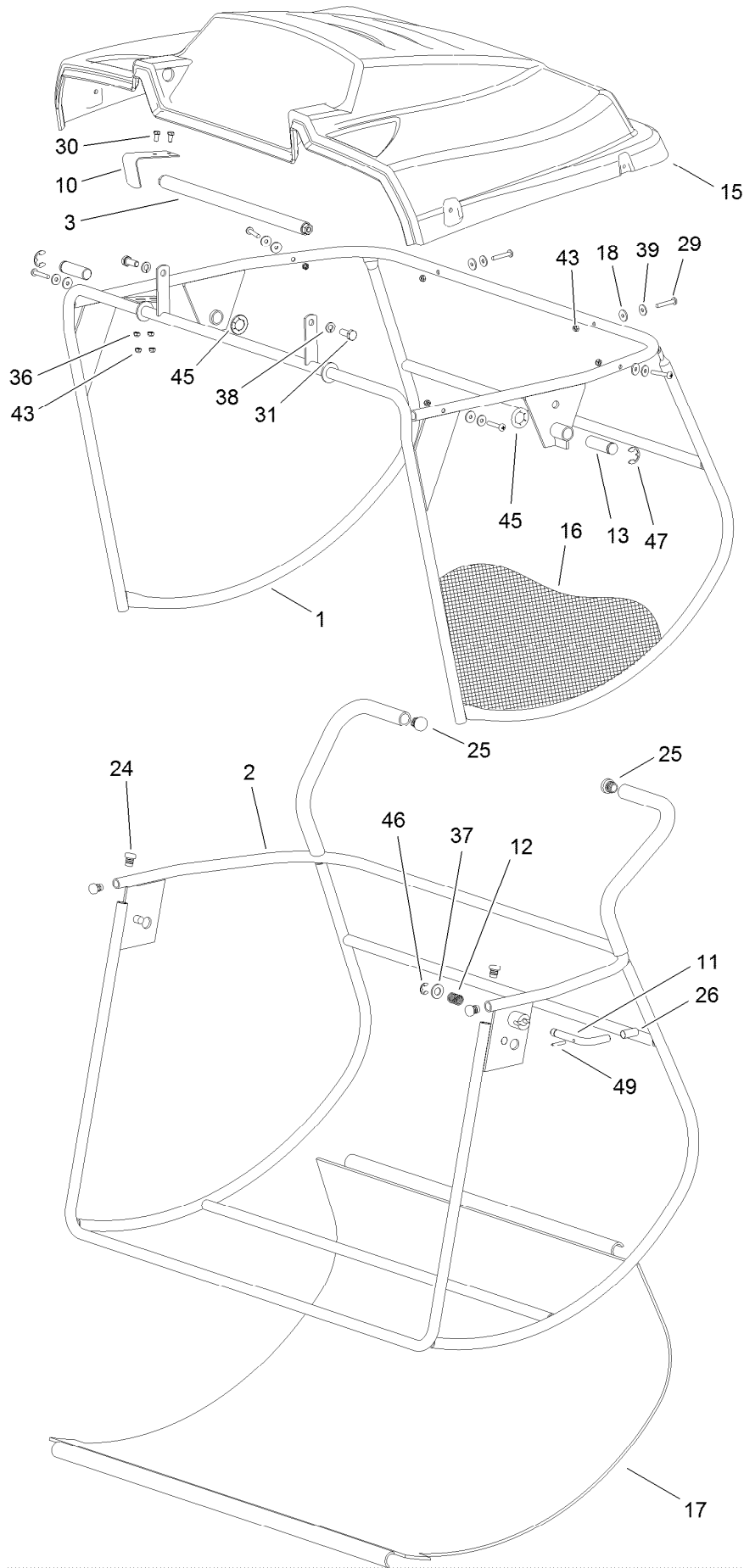

Grass Collector Assembly (continued)

<i>Ref.</i>	<i>Part Number</i>	<i>Qty.</i>	<i>Description</i>	<i>Ref.</i>	<i>Part Number</i>	<i>Qty.</i>	<i>Description</i>
1	119-5463	1	Upper Frame ASM	26	119-5473	1	Cap
2	119-5464	1	Lower Frame ASM	29	119-5476	6	Screw
3	119-5465	1	Handle-Lift	30	119-5477	2	Screw
10	119-5466	1	Bracket-Collector, Interlock	31	33114-020	2	Screw-HH
11	119-5467	1	Lever-Collector Lock	36	52-6430	2	Washer
12	119-5468	1	Spring	37	33095-00	1	Washer-Flat
13	119-5469	2	Pin	38	104-2927	2	Washer-Spring
15	119-5470	1	Cover-Collector	39	104-2943	2	Washer-Flat
16	119-5471	1	Bag-Grass	43	87-5140	8	Nut-Lock
17	119-5472	1	Bag-Lower	45	119-5478	2	Ring-Lock
18	104-2952	6	Washer-Rubber	46	104-3015	2	E-Clip
24	119-5475	4	Cap	47	119-5503	2	E-Clip
25	119-5474	2	Cap	49	119-5479	1	Pin

Tunnel Assembly

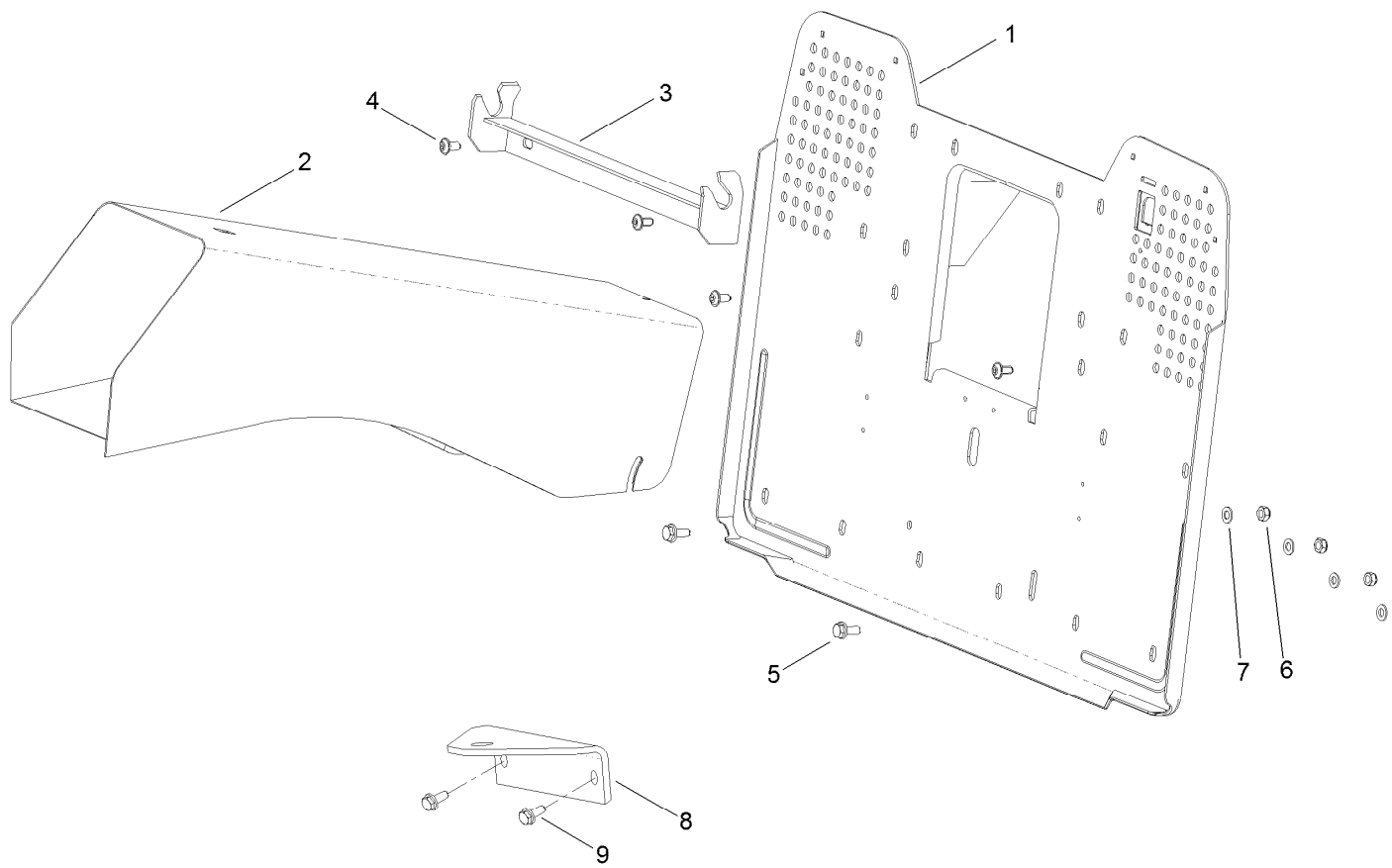

Tunnel Assembly (continued)

<i>Ref.</i>	<i>Part Number</i>	<i>Qty.</i>	<i>Description</i>	<i>Ref.</i>	<i>Part Number</i>	<i>Qty.</i>	<i>Description</i>
1	119-5480	1	Collector Plate ASM	6	33024-00	4	Nut-Lock, NI
2	119-5481	1	Tunnel	7	33094-00	4	Washer-Plain
3	119-5482	1	Support-Collector	8	119-5516	1	Hitch-Tow
4	104-3060	4	Bolt-Carriage	9	33104-025	2	Screw-HHF
5	119-5483	2	Screw				

Mulch Plug Assembly

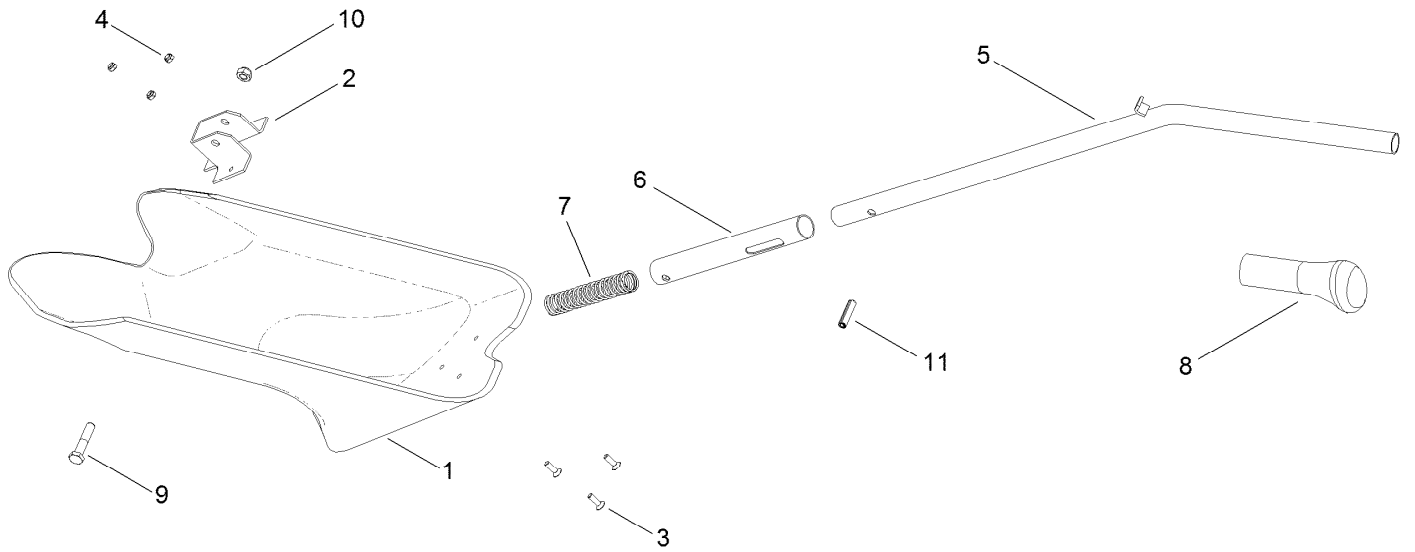

Mulch Plug Assembly (continued)

<i>Ref.</i>	<i>Part Number</i>	<i>Qty.</i>	<i>Description</i>	<i>Ref.</i>	<i>Part Number</i>	<i>Qty.</i>	<i>Description</i>
1	120-8732	1	Shield-Mulching	7	120-8736	1	Spring, Mulching
2	120-8733	1	Bracket-Shield, Mulching	8	120-8737	1	Handle-Mulching
3	120-8775	3	Screw	9	33114-040	2	Screw-HH
4	87-5140	3	Nut-Lock	10	33024-00	1	Nut-Lock, NI
5	120-8734	1	Handle-Mulching, Top	11	121-0964	1	Pin-Spiral
6	120-8735	1	Handle-Mulching, Bottom				

Attachments and Accessories

For 74560 DH 140 Lawn Tractor

Product Name	Model/Part
Rear Discharge Chute Kit	117-0054
Belt Guard Kit	120-1180

Notes:

Notes:

Notes:



Count on it.