



MODEL NO. 22030 - 0000001 THRU
1000001 & UP
MODEL NO. 22035 - 0000001 THRU
1000001 & UP

OPERATOR'S MANUAL

21" (0.53 M) COMMERCIAL REAR BAGGER

SAFETY INSTRUCTIONS

This mower "meets or exceeds the B71.4-1984 specifications of the American National Standards Institute for walk behind rotary mowers. However, improper use or maintenance by the operator or owner can result in injury. To reduce the potential for injury, comply with these safety instructions and always pay attention to the safety alert symbol . Failure to comply with these instructions may result in personal injury. This product does not comply with the Consumer Product Safety Commission's safety requirements for walk behind lawn mowers. This product is intended for commercial use only.

BEFORE OPERATING

1. Read this manual carefully before operating the mower. Become familiar with the controls and proper use of the mower. Never allow children to operate the mower or adults to operate it without proper instructions.
2. Keep everyone, especially children and pets, away from area of operation. Thoroughly inspect area where mower will be used and remove sticks, stones, wire, and debris.
3. Wear long pants and substantial shoes. Do not operate mower while wearing open sandals or when barefoot.
4. Always wear safety glasses or eye shields during operation to protect eyes from foreign objects that may be thrown from the machine.
5. Check fuel level before starting engine. Do not fill fuel tank indoors, when the engine is running, or until engine cools for several minutes after running. Wipe up spilled gasoline before starting engine.
6. Keep all guards, shields, and safety devices in place. Repair or replace defective or damaged parts.
7. Traction drive is designed to stop when the control bar is released. Assure control bar functions properly before each use of mower.

WHILE OPERATING

8. Do not run engine indoors.
9. Always maintain secure footing. Keep a firm grip on the handle and walk; never run. Never operate mower in wet grass. Mow only in daylight or in good artificial light.

10. Mow across the face of slopes; never up and down. Use extreme caution when changing direction on slopes. Do not mow excessively steep slopes.

11. Keep face, hands, and feet away from the mower housing and cutter blade when the engine is running. Stay behind the handle until the engine stops and keep clear of discharge opening at all times.

12. When mulching, remove grass bag and ensure discharge door is closed and locked completely. When bagging grass, stop engine and assure chute door is closed before the bag is removed and emptied.

13. Shut engine off and wait for all moving parts to stop before unclogging chute. Use a stick, not your hand, to unclog chute.

14. Since the blade rotates for a few seconds after the engine is stopped, stay behind the handle until all moving parts stop.

15. After striking a foreign object or if mower vibrates abnormally, stop engine and remove wire from spark plug. Check mower for damage and make all repairs before using mower again.

16. Shut off engine and wait for all moving parts to stop before adjusting the height-of-cut.

17. Stop the engine when crossing a gravel driveway, road or sidewalk.

18. Stop engine before leaving the operator's position—behind the handle. Disconnect wire from spark plug if mower will be unattended.

19. Do not touch engine while it is running or shortly after it is stopped because engine will be hot enough to cause a burn.

SAFETY INSTRUCTIONS

MAINTENANCE

20. Perform only those maintenance instructions described in this manual. If major repairs are ever needed or if assistance is desired, contact your local Authorized TORO Service Dealer.
21. Before mower is cleaned, inspected, serviced, or adjusted, stop engine and disconnect wire from spark plug. Keep wire away from plug to prevent accidental starting.
22. To assure the mower is in safe operating condition, frequently check and keep all nuts, bolts, and screws tight. Assure blade bolt is tightened to 50 ft-lb (68 N-m).
23. To reduce fire hazard, keep engine free of excessive grease, grass, leaves, and accumulation of dirt.
24. Check grass catcher bag frequently for wear or deterioration. Replace with a new bag for your protection.
25. Allow engine to cool before storing mower in any enclosure. Do not store mower near any open flame or where gasoline fumes may be ignited by a spark.
26. Do not overspeed the engine by changing governor settings.
27. At the time of manufacture, the mower conformed to the safety standards in effect for rotary mowers. To assure best performance and continued safety certification of the mower, use genuine TORO replacement parts and accessories. Replacement parts and accessories made by other manufacturers may result in non-conformance with the safety standards, and that could be dangerous.

SAFETY DECALS AND INSTRUCTIONS

Safety decals and instructions are easily visible to the operator and are located near any area of potential danger. Replace any decal that is damaged or lost.

This Mower Intended For Commercial Use Only. Does Not Comply With Mandatory Safety Standard For Consumer Mowers.

ON REAR OF MOWER
Model 22030 only
(Part No. 48-2930)



ON MOWER HOUSING
(Part No. 39-5770)



ON CONTROL BAR
Model 22035 only
(Part No. 71-1290)



ON STEP PAD
(Part No. 46-7370)



ON MOWER HOUSING
(Part No. 71-1280)

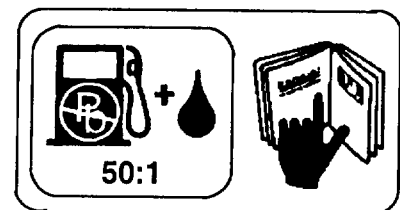

ON ENGINE
(Part No. 62-7600)

TABLE OF CONTENTS

	Page		Page
Set-Up Instructions	3	Inspecting/Removing/Sharpening Blade	10
Before Operating	5	Lubrication	11
Operating Instructions	6	Lubricating Gear Case	11
Maintenance	8	Servicing Wheels	12
Servicing Air Cleaner	8	Cleaning Mower Housing	12
Replacing Spark Plug	8	Preparing Mower For Storage	12
Draining Gasoline	8	Optional Equipment	13
Adjusting Throttle	9	Toro Service Support	13
Cleaning Cooling System	9	Product Identification	13
Cleaning Muffler Exhaust Port	9	Maintenance Record	14
Adjusting Wheel Drive	10	The Toro Promise	

SET-UP INSTRUCTIONS

INSTALL HANDLE (Fig. 1)

1. Mount handle to outside of mower housing, using top hole, with (2) 5/16-18 x 1-1/2" lg. capscrews, washers, spacers, and nylon insert locknuts.

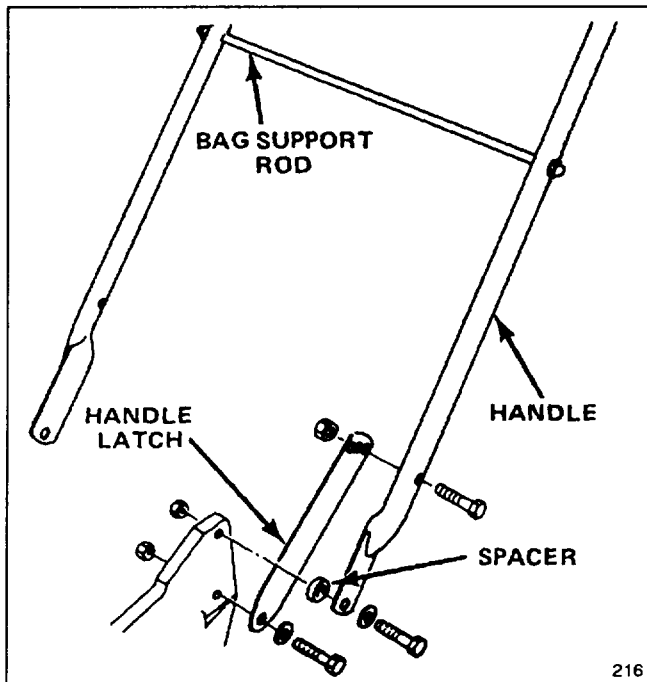

Figure 1

2. Mount handle latches to outside of mower housing, using bottom hole, with (2) 5/16 x 18 x 1-1/4" lg. capscrews, washers, and locknuts.

3. Secure handle latches to handle with (2) 5/16-18 x 1-1/2" lg. capscrews and nylon insert locknuts. Position locknuts on inside of handle.

Note: Handle height is adjustable for operator comfort. Stand behind mower handle to gauge height. To adjust handle height, reposition capscrews and locknuts securing handle latches to handle into other mounting holes in latches.

4. Slide bag support rod thru top mounting holes in handle and secure each end with (2) cap locknuts.

INSTALL GAS TANK

1. Hook the plastic clips on the rear of the gas tank onto the gas tank bracket (Fig. 2).

2. Secure gas tank to tank base with (2) self-tapping screws (Fig. 2). Do not overtighten screws.

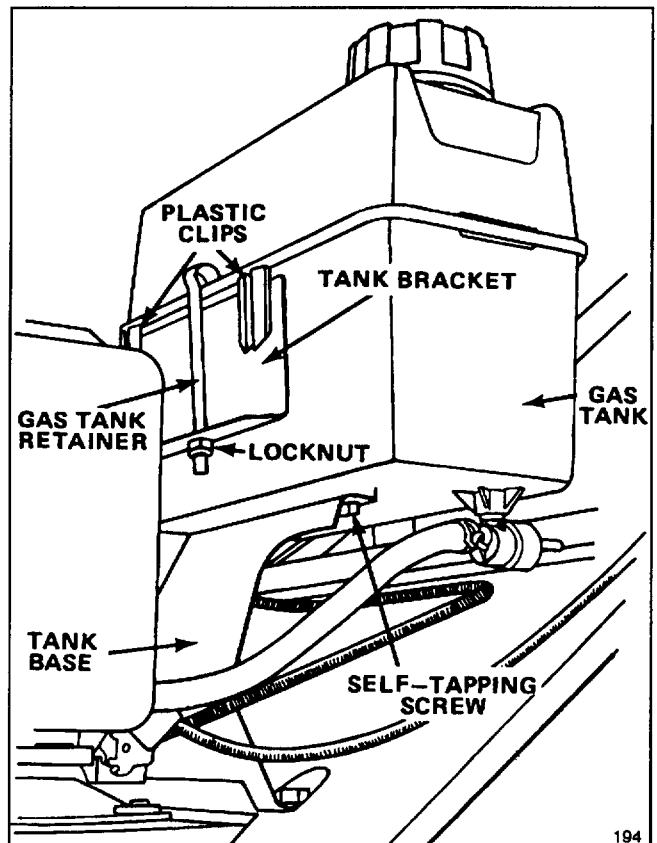

Figure 2

SET-UP INSTRUCTIONS

- Hook gas tank retainer onto gas tank and slide end of retainer into hole in tank bracket. Secure retainer to tank bracket with locknut (Fig. 2). Do not overtighten locknut.
- Slide end of fuel line onto fuel shut-off valve fitting. Secure in place with fuel line clamp (Fig. 3).

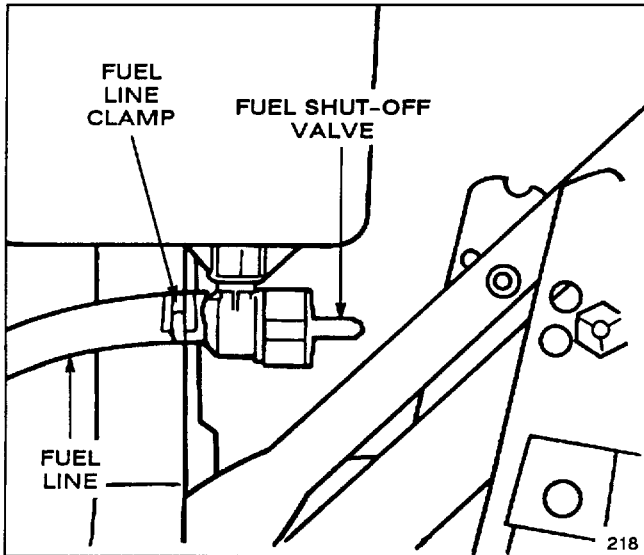

Figure 3

INSTALL AIR CLEANER COVER (Fig. 4)

- Insert bottom tabs of air cleaner cover into slots. Rotate cover upwards and snap into place.

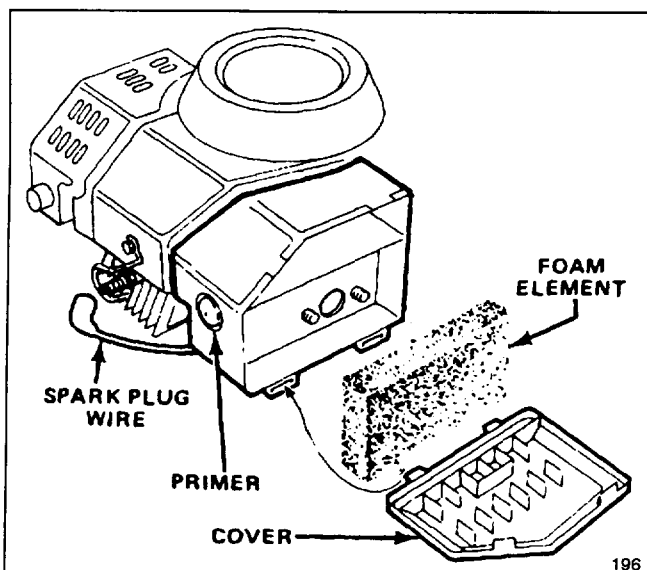

Figure 4

ASSEMBLE BAG TO MOWER

- Assure chute door handle is fully forward and locked in place (Fig. 5).
- Slide guide hole in bag door onto locking stud on mower housing (Fig. 5); then set rear of bag frame onto support rod.
- Squeeze lockout lever until it clears the housing latch (Fig. 6). Then move handle rearward until lockout lever locks in notch at rear of bag door (Fig. 6). The chute door in mower housing is now open and mower is ready to bag grass clippings.

Note: Bag door may need to be forced downward onto housing latch to release the lockout lever.

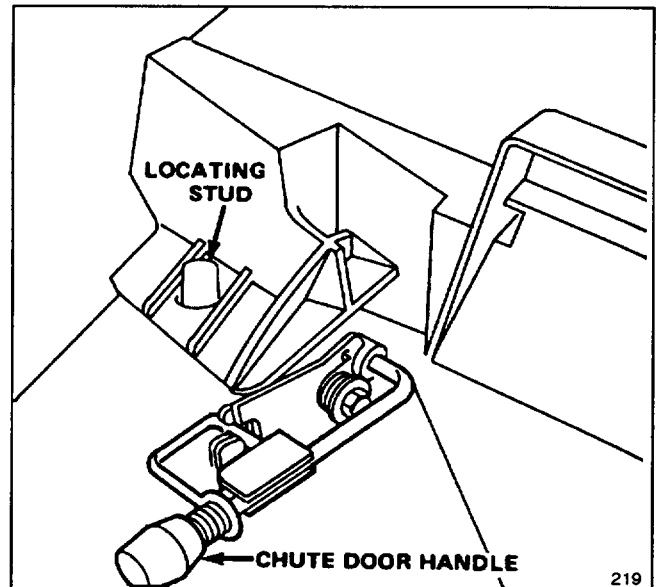

Figure 5

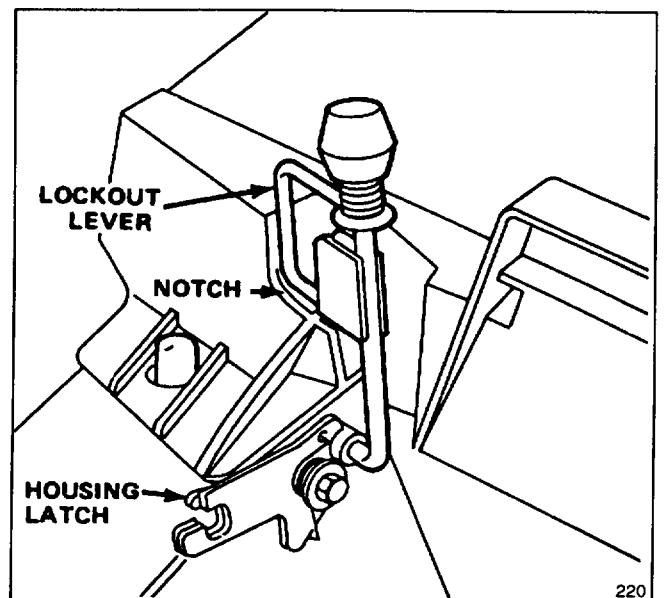

Figure 6

BEFORE OPERATING



WARNING

DANGER: Gasoline is extremely flammable and explosive under certain conditions. Do not smoke when handling fuel and keep fuel far away from open flames and sparks. Never buy more than a 30 day supply of gasoline. Store it in an approved container. Keep gasoline out of reach of children.

Refuel outdoors and only when engine is cold. Fill tank to within 1/4" to 1/2" (6 to 13 mm) from bottom of filler neck, not into filler neck. This space is for expansion of fuel. Use funnel or spout to prevent spilling. Wipe up any spilled gas.

MIX GASOLINE AND OIL—50:1 RATIO

1. **APPROVED OIL**—For simplicity and best engine performance, mix the contents of one bottle of Toro 50:1 Two-Cycle Oil with two gallons of fresh, unleaded regular gasoline. Leaded regular gasoline may be used if unleaded regular is not available.

Toro Two-Cycle Oil is specially formulated to provide superior lubrication, make starting easy, and prolong engine life. If Toro Two-Cycle Oil is not available, mix two gallons of gasoline and 5.2 ounces of another high grade two-cycle oil that has the NMMA or BIA-TCW certification printed on the label.

50:1 GAS/OIL Mixing Chart

U.S. GALLON	
Gasoline	Oil
1 gallon	2.6 oz.
2 gallons	5.2 oz.

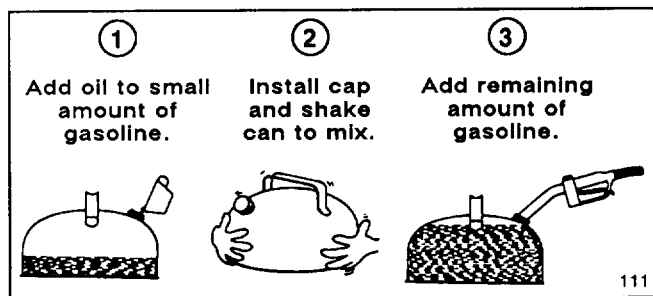

Figure 7

IMPORTANT: YOU CAN ALSO USE TORO "EASY-MIX" TWO-CYCLE OIL (3.2 OUNCE BOTTLE MIXED ONE PER GALLON OF GASOLINE) IN THIS TORO TWO-CYCLE ENGINE.

NEVER USE AUTOMOTIVE OIL (i.e. SAE 30, 10W30 etc.), TWO-CYCLE OIL THAT IS NOT CERTIFIED NMMA/BIA-TCW, OR THE WRONG MIX RATIO BECAUSE THE ENGINE CAN BE DAMAGED, AND IT WOULD NOT BE COVERED BY THE TORO WARRANTY.

Toro also recommends that Toro Stabilizer/Conditioner be used regularly in all Toro gasoline powered products during operation and storage seasons. Toro Stabilizer/Conditioner cleans the engine during operation and prevents gum-like varnish

deposits from forming in the engine during periods of storage.

2. **Mixing Gasoline and Oil (Fig. 7)**—Pour correct amount of two-cycle oil into an approved gasoline container and add a half gallon of gasoline. Install cap on gasoline container and shake the container to mix oil and gas thoroughly. Remove cap and add remaining amount of gasoline.

IMPORTANT: NEVER USE METHANOL, GASOLINE CONTAINING METHANOL, GASOHOL CONTAINING MORE THAN 10% ETHANOL, PREMIUM GASOLINE, OR WHITE GAS BECAUSE ENGINE FUEL SYSTEM DAMAGE COULD RESULT.

DO NOT USE FUEL ADDITIVES OTHER THAN THOSE MANUFACTURED FOR FUEL STABILIZATION DURING STORAGE SUCH AS TORO'S STABILIZER/CONDITIONER OR A SIMILAR PRODUCT. TORO'S STABILIZER/CONDITIONER IS A PETROLEUM DISTILLATE BASED CONDITIONER/STABILIZER. TORO DOES NOT RECOMMEND STABILIZERS WITH AN ALCOHOL BASE SUCH AS ETHANOL, METHANOL OR ISOPROPYL. ADDITIVES SHOULD NOT BE USED TO TRY TO ENHANCE THE POWER OR PERFORMANCE OF MACHINE.

NOTE: Do not mix gasoline and oil in the product fuel tank. Oil that is at room temperature mixes easier and more thoroughly than cold oil.

3. Turn fuel shut-off valve to ON position (Fig. 8).

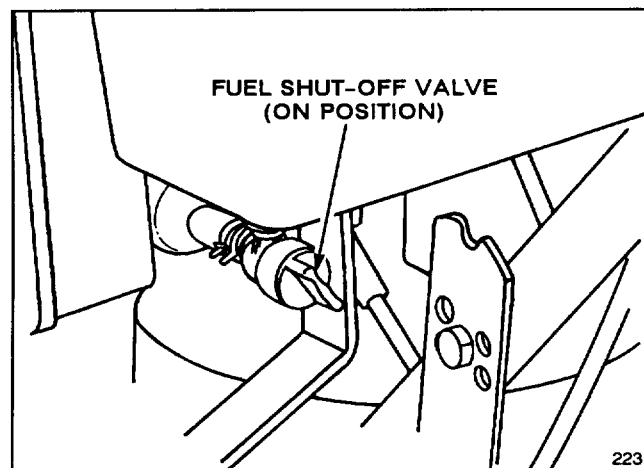

Figure 8

OPERATING INSTRUCTIONS

OPERATING TIPS

1. **CUTTING AND BAGGING**—To improve quality of cut, discharge clippings toward previously cut area. Best results are achieved when engine is running at maximum speed and only about 1/3 of the grass blade is cut. If long grass must be cut, use highest height-of-cut setting for first mowing. Then recut the grass at a more normal setting. If too long of grass is cut, mower may plug and cause engine to stall.

2. **SHARP BLADE**—Begin each cutting season with a sharp blade. Periodically file down nicks.

STARTING, STOPPING, AND SELF-PROPELLING

1. **CONTROLS**—Throttle control and control bar (Model 22035) are on upper handle. Ground speed control (Model 22035) is located at rear of belt cover. Fingertip starter is on engine.

2. Push spark plug wire onto spark plug.

3. **STARTING (Model 22030)**—Move throttle to CHOKE. Pull fingertip starter out slowly until positive engagement results; then pull vigorously to start the engine. Regulate throttle as desired when engine starts (Fig. 9).

NOTE: A cold engine will start easier by pumping the primer bulb 3–5 times before pulling the starter rope.

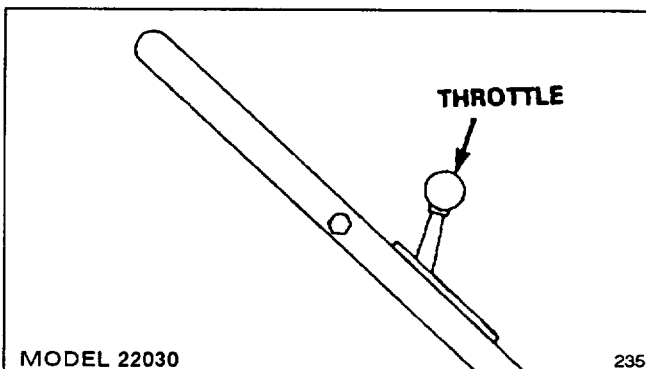

Figure 9

NOTE: When starting a warm engine, CHOKE may not be necessary.

4. **STARTING (Model 22035)**—Move ground speed control to desired speed selection (Fig. 11) and throttle to CHOKE. Pull fingertip starter and regulate throttle as desired when engine starts (Fig. 10).

NOTE: When starting a warm engine, CHOKE may not be necessary.

5. **STOPPING**—To stop engine, move throttle to stop position. Pull wire off spark plug if mower will be unattended or not used.

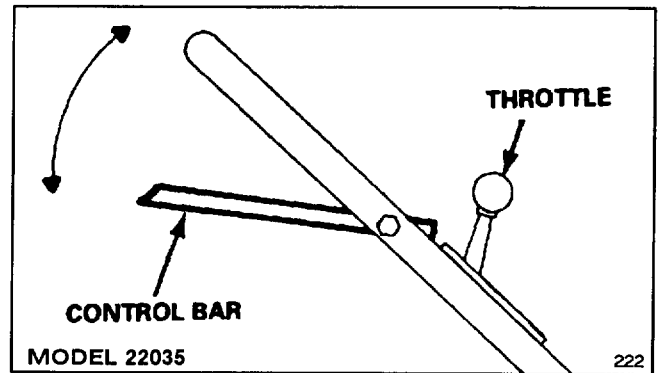

Figure 10

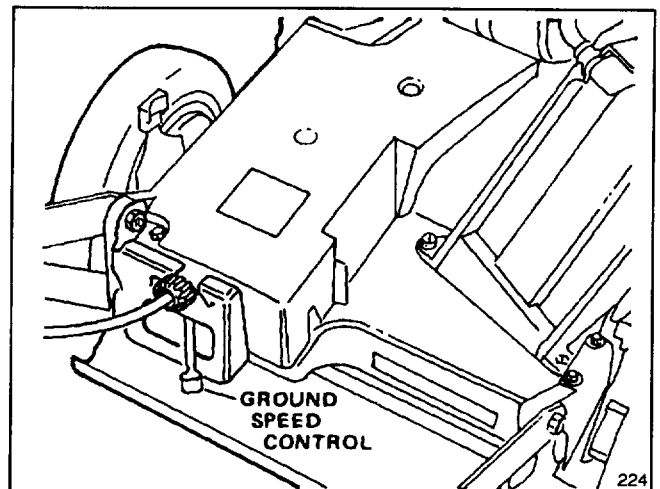

Figure 11

USING GRASS BAG

Keep bag installed when bagging or mulching.

1. Stop engine and wait for all parts to stop.
2. Assure chute door handle is fully forward and lockout lever is released into latch (Fig. 12).

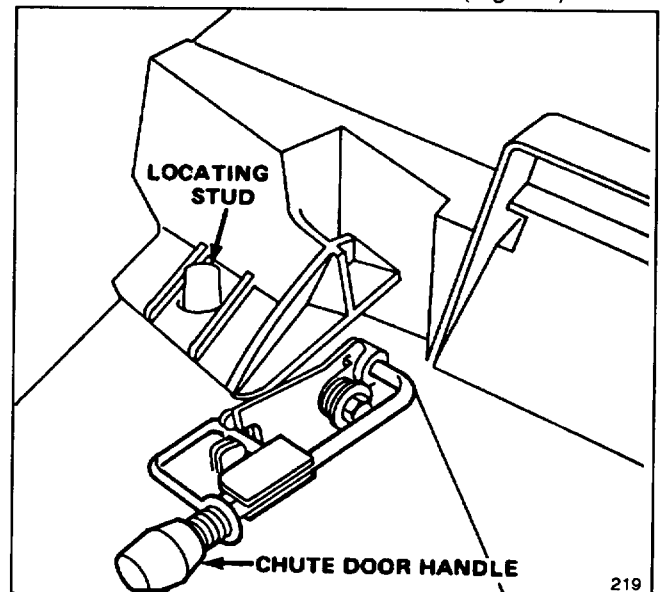

Figure 12

OPERATING INSTRUCTIONS

3. **INSTALLING BAG**—Slide hole in bag frame onto retaining collar on housing (Fig. 12) and set rear of bag frame onto support rod on handle.

4. Squeeze lockout lever until it clears the housing latch, then move handle rearward until it locks in notch at rear of bag latch (Fig. 13). The chute door in mower housing is now open and mower is ready to bag grass.

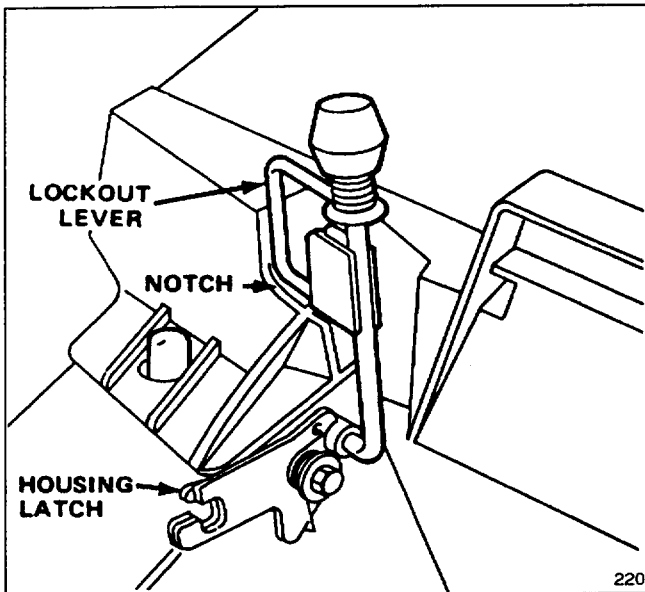

Figure 13

CAUTION

Except when side discharge attachment is used, never open chute door on mower when engine is running because grass clippings and other debris discharges with enough force to cause injury.

The grass bag material will catch and contain the majority of foreign objects such as small stones and other similar debris. The bag material, however, is subject to normal wear and deterioration. So check the bag frequently, and if it is defective, install a new genuine TORO replacement bag that has this or similar warning.

CAUTION

If chute door cannot be closed because grass clippings clog discharge area, gently move chute door handle back and forth until door can be closed completely. Do not force chute door closed because door or handle may be damaged. If door still cannot be closed, make sure engine is stopped and remove obstruction.

5. **EMPTYING BAG**—Stop engine and wait for blade to stop. Move chute door handle forward until it locks in the latch (Fig. 12). Grasp handle at front and rear of bag and lift bag off mower. Gradually tip bag forward to empty clippings.

6. To reinstall bag, repeat steps 3 and 4.

ADJUSTING HEIGHT-OF-CUT

The height-of-cut is adjustable from approximately 3/4 to 3-1/4 inches (19 mm to 83 mm), in 1/2 (12.7 mm) increments. Moving height-of-cut adjuster forward raises height-of-cut.

1. Stop the engine.
2. For easier adjustment, lift housing up so wheel is off ground. Do not place hands under deck to lift housing. Squeeze adjusting lever toward wheel (Fig. 14) and move it to the desired setting. Assure pin on adjusting lever engages notch in mower housing wear plate. Adjust all wheels to the same setting.

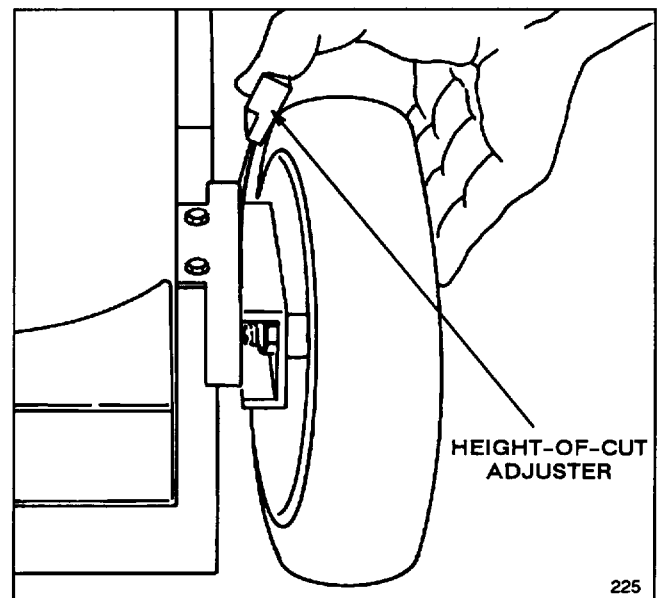

Figure 14

MAINTENANCE



CAUTION

Pull wire off spark plug before performing adjustments or maintenance.

SERVICING AIR CLEANER

Normally, clean air cleaner after every 25 operating hours. More frequent cleaning is required when mower is operated in dusty or dirty conditions.

1. Stop engine and pull wire off spark plug (Fig. 15).
2. Lift tabs at top of air cleaner cover and pivot cover down. Clean cover thoroughly.
3. If outside of foam element is dirty, remove it from air cleaner body. Clean thoroughly.
 - A. WASH foam element in a solution of liquid soap and warm water. Squeeze to remove dirt, but do not twist because foam may tear. Rinse thoroughly in clear water.
 - B. DRY by wrapping in a clean rag. Squeeze rag and foam element to dry.

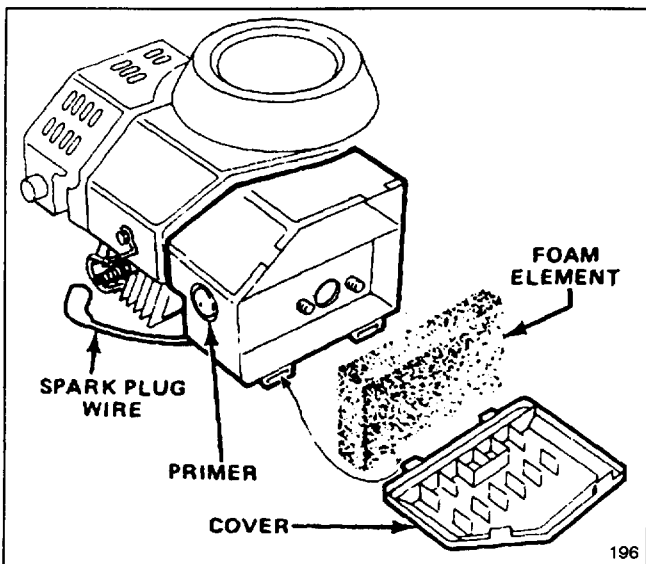

Figure 15

C. SATURATE element with 5 teaspoons (25 ml) of SAE 30 engine oil. Squeeze element to remove excess oil and to distribute oil thoroughly. A damp element is desirable.

4. Reinstall foam element and air cleaner cover.

IMPORTANT: Do not operate engine without air cleaner element because extreme engine wear and damage will likely result.

REPLACING SPARK PLUG

Use an NGK BPMR4A spark plug or equivalent. Correct air gap is 0.032" (0.81 mm). Remove plug after every 25 operating hours and check its condition.

1. Stop engine and pull wire off spark plug (Fig. 15).
2. Clean around spark plug and remove plug from cylinder head.

IMPORTANT: Replace a cracked, fouled, or dirty spark plug. Do not sand blast, scrape, or clean electrodes because engine damage could result from grit entering cylinder.

3. Set air gap at 0.032" (0.81 mm) (Fig. 16). Install correctly gapped spark plug and gasket seal. Tighten plug firmly to 10 ft-lb (13.6 N-m).

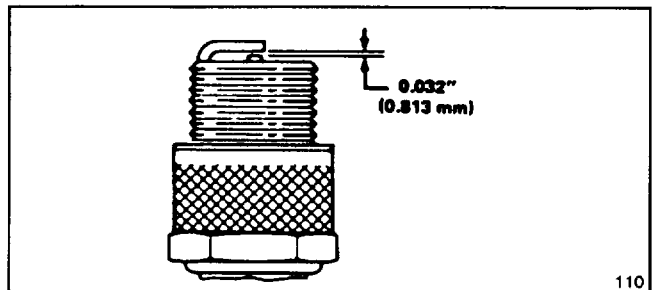

Figure 16

DRAINING GASOLINE

1. Stop engine and pull wire off spark plug (Fig. 15).
2. Turn fuel shut-off valve to OFF position (Fig. 17).
3. Remove cap from fuel tank and use pump-type syphon to drain fuel into clean gas can.

Note: This is the only procedure recommended for draining fuel.

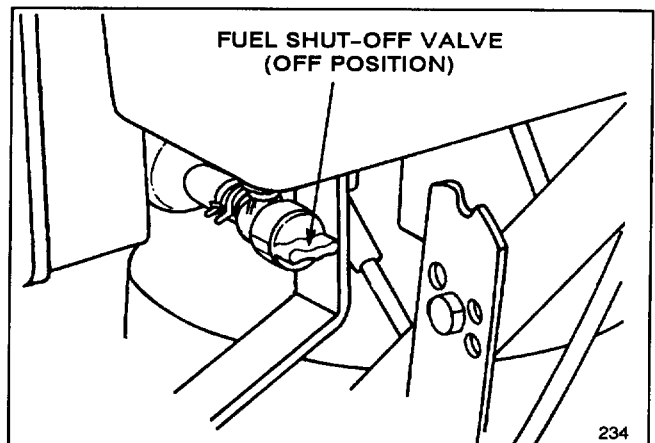

Figure 17

MAINTENANCE

ADJUSTING THROTTLE

Throttle control adjustment may be required if engine does not start or stop. Whenever a new throttle control cable is installed, throttle must be adjusted.

1. Stop engine and pull wire off spark plug (Fig. 15).
2. Close door on mower housing and remove grass bag.

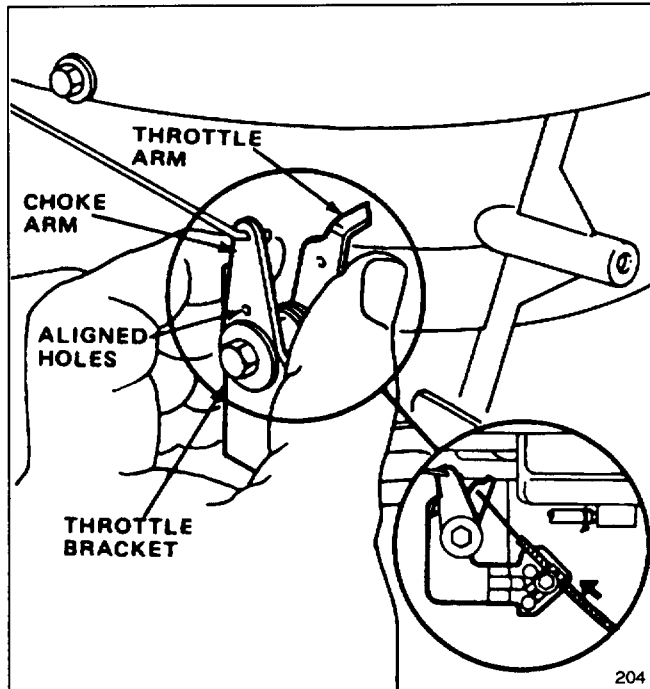

Figure 18

3. Move throttle control to FAST.
4. Loosen cable clamp screw until throttle cable slides (Fig. 18). Align holes in choke arm and throttle bracket. A small dia. pin may be inserted into aligned holes to hold adjustment. Push throttle cable until throttle arm makes contact with choke arm. Tighten cable clamp screw. Remove pin if used.

CLEANING COOLING SYSTEM

After every 75 operating hours, clean dirt and chaff from cylinder, cylinder head fins and from around carburetor and linkage. Also remove debris from air intake slots on recoil housing. This will assure proper cooling and optimum engine performance.

CLEANING MUFFLER AND EXHAUST PORT

Clean end of muffler pipe and exhaust port after every 75 hours of operation.



Clean muffler and exhaust port only after engine and muffler are cool. A hot engine and muffler can cause burns.

1. Use hard wood scraper and remove carbon from end of muffler pipe (Fig. 19).
2. Remove screw, two nuts, and lockwashers (Fig. 19). Slide muffler off mounting pins.

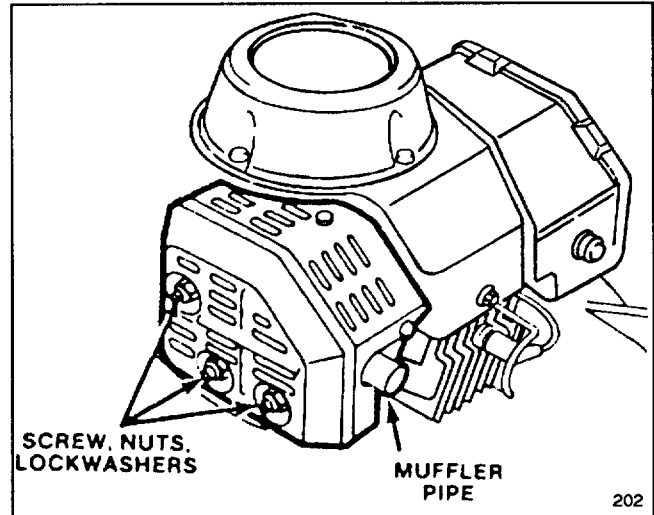

Figure 19

3. Pull wire off spark plug. Slowly pull recoil starter so piston covers exhaust port (Fig. 20).

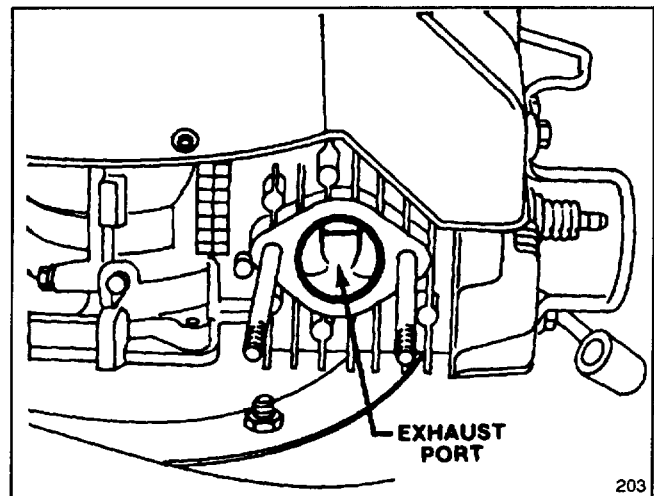

Figure 20

4. Clean carbon from exhaust port (Fig. 20) with flat, hard wood scraper.
IMPORTANT: Do not use a metal scraper or similar object to clean exhaust port because accidental damage to the piston or cylinder could easily occur.
5. Reinstall muffler with screw, (2) nuts and lockwashers (Fig. 20). After cleaning exhaust port, make sure muffler gasket is still usable.

MAINTENANCE

ADJUSTING WHEEL DRIVE (MODEL 22035)

If mower does not self-propel or has a tendency to creep forward when drive is not engaged, adjust wheel drive control knob on rear of gear box.

1. Close door in mower housing and remove bag.
2. ADJUSTMENT (Fig. 21)—Rotate control knob clockwise 1/2 turn if mower does not self-propel. If mower creeps forward, rotate knob 1/2 turn counterclockwise to loosen belt.

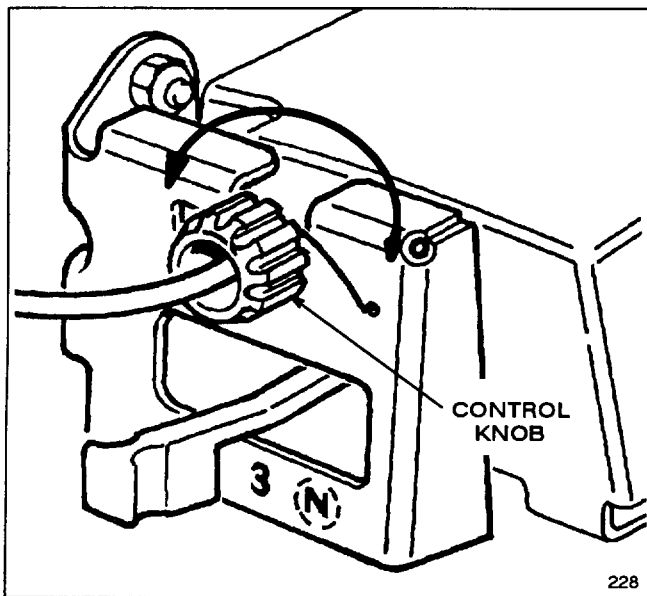

Figure 21

3. CHECK ADJUSTMENT—Slowly pull mower backward while control bar is gradually moved toward handle. Adjustment is correct when rear wheels stop turning and control bar is about 1-inch from handle (Fig. 22).

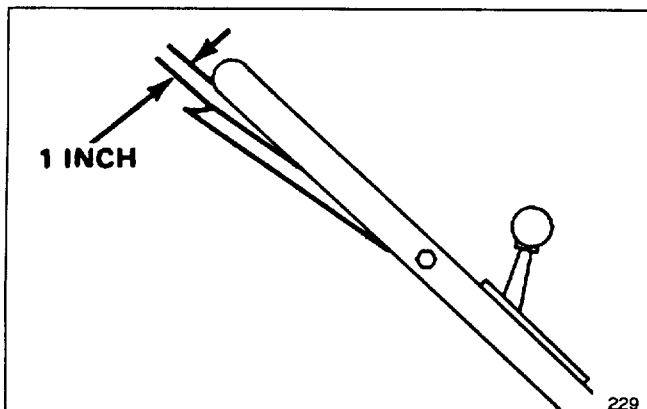

Figure 22

INSPECTING/REMOVING/SHARPENING BLADE

1. Stop engine and pull wire off spark plug (Fig. 15).
2. Drain gasoline from fuel tank; refer to Draining Gasoline, page 8.
3. Tip mower on its right side (Fig. 23). Avoid rotating blade as starting problems may result.



CAUTION

Do not attempt to inspect, remove or replace blade without first removing the spark plug wire from spark plug and fastening it away from accidental contact with spark plug.

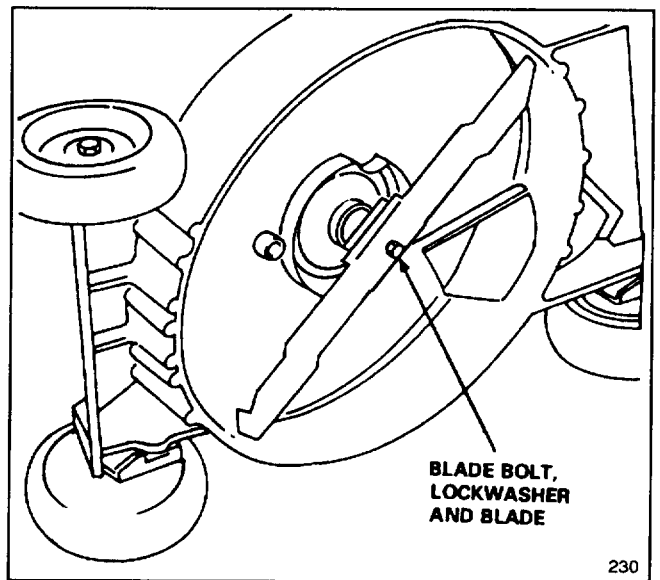

Figure 23

4. INSPECTING BLADE—Carefully examine blade for sharpness and wear, especially where flat and curved parts meet (Fig. 24A). Since sand and abrasive material can wear away the metal that connects the flat and curved parts of the blade, check blade before using the mower. If a slot or wear is noticed, (Fig. 24B & C), replace blade. Refer to step 5.

Note: For optimum performance, install new blade before cutting season begins. During the year, file down small nicks to maintain the cutting edge.



CAUTION

If blade is allowed to wear, a slot may form near the sail. Eventually a piece of blade may break off resulting in serious injury to yourself or a bystander.

MAINTENANCE

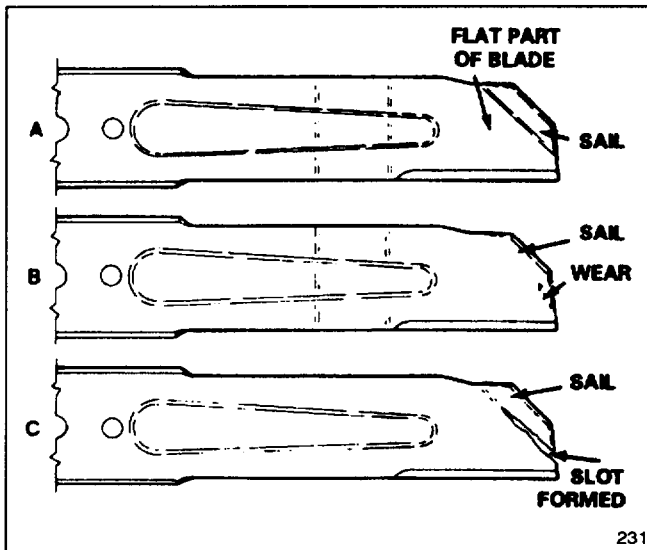

Figure 24

5. REMOVING BLADE—Grasp end of blade using a rag or thickly padded glove. Remove blade bolt, lockwasher, and blade (Fig. 23).

6. SHARPENING BLADE—Using a file, sharpen top side of blade and maintain original cutting angle (Fig. 25). The blade will remain balanced if same amount of material is removed from both cutting edges.

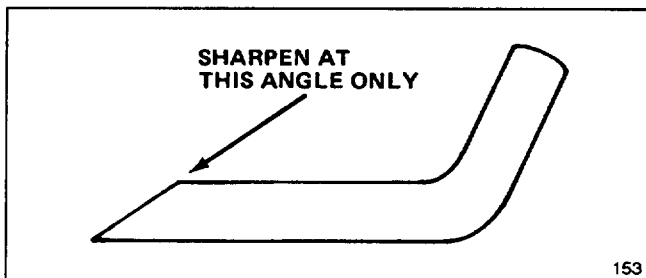

Figure 25

IMPORTANT: Check balance of blade by putting it on a blade balancer. An inexpensive balancer can be purchased at a hardware store. A balanced blade stays in a horizontal position and an unbalanced blade settles to the heavy side. If blade is not balanced, file more metal off cutting edge on heavy end of blade.

7. Install sharp, balanced blade with lockwasher and blade bolt. Sail part of blade must point toward top of mower housing to assure correct installation. Tighten blade bolt to 50 ft-lb (68 N-m).

LUBRICATION

After every 25 operating hours or when season ends, pivot arms must be lubricated.

1. Move rear wheel height-of-cut levers to center setting. Wipe grease fittings with clean rag (Fig. 26). Install grease gun onto fitting and gently apply 2 or 3 pumps of #2 Multi-Purpose Lithium Base Grease. Excessive grease pressure may damage seals.

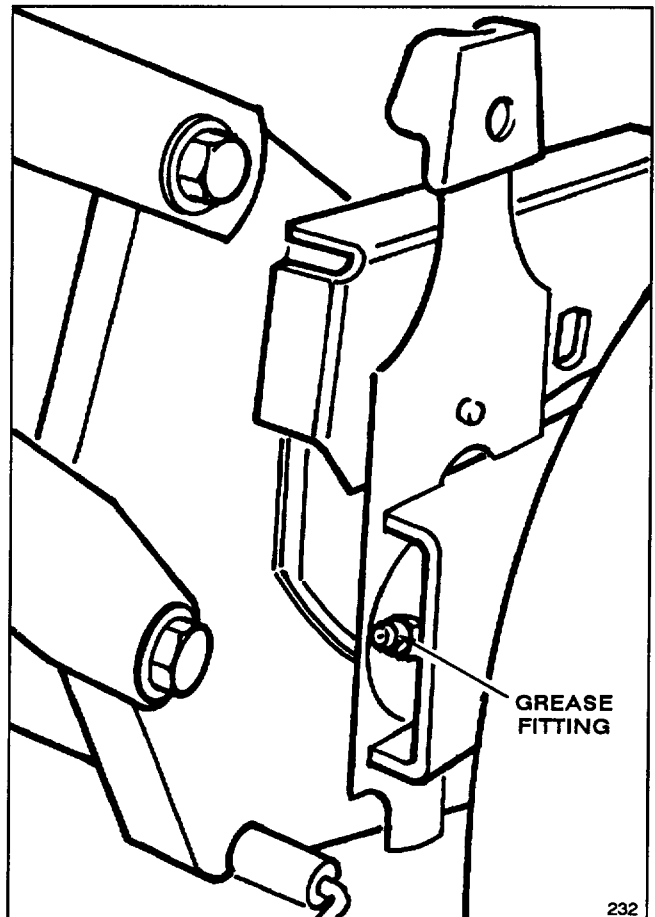

(Model 22035 shown)

Figure 26

LUBRICATING GEAR CASE (MODEL 22035)

After every 100 operating hours, grease the gear case with #2 Multi-Purpose Lithium Base Grease.

1. Remove bag.
2. Install grease gun onto fitting thru belt cover opening (Fig. 27). Gently apply 1-2 pumps of grease.
3. Reinstall bag.

MAINTENANCE

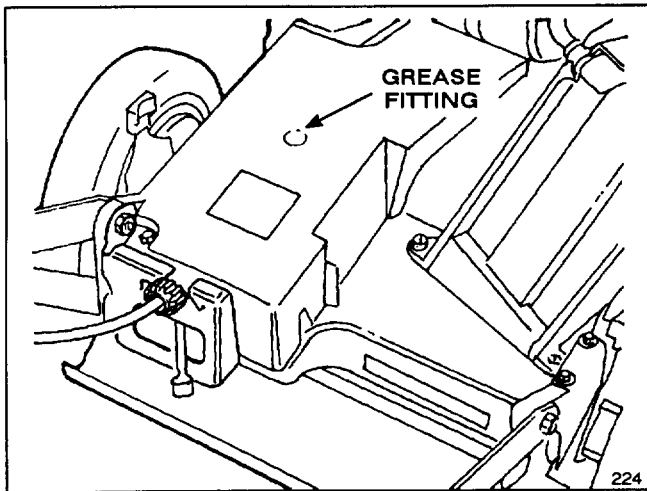

Figure 27

SERVICING WHEELS (Fig. 28)

Removal

1. Stop engine and remove capscrew, wheel spacer, and locknut mounting wheel to pivot arm.

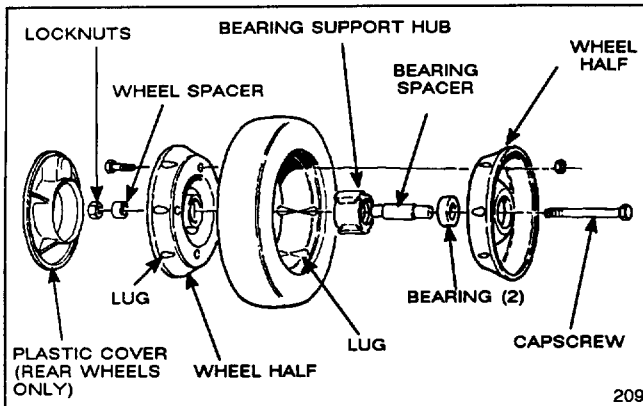

Figure 28

2. Separate wheel halves from tire by removing (4) capscrews and locknuts.

Note: If bearings are to be removed from bearing support hub, remove by pressing on bearing spacer.

Assembly

1. Position tire onto (1) wheel half aligning lugs on each.
2. Place bearing support hub into center hole of wheel half. Make sure legs of hub are positioned over flange of hole.
3. Place other wheel half onto bearing support hub aligning wheel and tire lugs and mounting holes.
4. Using (2) 1/4–20 x 1.50" lg. fully threaded screws or bolts and non-locking nuts, loosely secure wheel halves together. Mount screws or bolts in opposing holes.

5. Check alignment of all parts and tighten screws, alternating from side to side for a uniform fit, until wheel halves are drawn together.

6. Install (2) capscrews and locknuts, previously removed, in remaining holes in wheel halves and tighten. Remove (2) long screws or bolts and replace with (2) capscrews and locknuts.

7. Reinstall wheel to pivot arm with capscrews, spacer, and locknut. Make sure spacer is positioned between wheel hub and pivot arm.

CLEANING MOWER HOUSING

To assure optimum performance, keep underside of mower housing and inside of discharge area clean.

1. Drain gasoline from fuel tank: refer to Draining Gasoline, page 8.

2. Tip mower on its right side. Avoid rotating blade because starting problems may result.

3. Remove dirt and grass clippings that stick to housing by spraying it with a garden hose. Scrape out remaining debris with hardwood scraper. Avoid burrs and sharp edges.

PREPARING MOWER FOR STORAGE

1. For long term storage, either drain gasoline from fuel tank or add a fuel stabilizer to the gasoline. To drain gasoline, refer to Draining Gasoline, page 8. After fuel is drained, start engine and let it idle until all fuel is consumed and engine stops. Repeat the starting procedure two more times to assure all gas is removed from the engine. If gasoline is not drained, gum-like varnish deposits will form and cause poor engine operation, even starting problems.

Fuel can be left in gas tank only if a fuel additive, such as Toro's Stabilizer/Conditioner, is added to gasoline and run through engine before storing. Toro's Stabilizer/Conditioner is a petroleum distillate based conditioner/stabilizer. Toro does not recommend stabilizers with an alcohol base, such as ethanol, methanol or isopropyl. Use fuel additive in recommended quantities as specified on container.

Under normal conditions, all fuel additives remain effective in fuel for 6–8 months.

2. Remove spark plug and pour 2 teaspoons of Toro two-cycle oil into hole in cylinder. Pull starter rope slowly to coat inside of cylinder. Install spark plug and tighten to 10 ft-lb (13.6 N-m). **DO NOT INSTALL WIRE ON SPARK PLUG.**

3. Clean underside of housing: refer to Cleaning Mower Housing, page 12.

4. Check condition of blade: refer to Inspecting/Removing/Sharpening Blade, page 10.

5. Tighten all nuts, bolts, and screws.

MAINTENANCE

6. Clean dirt and chaff from cylinder, cylinder head fins, and blower housing. Also remove grass clippings, dirt, and grime from external parts of the engine, shrouding, and top of mower housing.
7. Clean air cleaner: refer to Servicing Air Cleaner, page 8.
8. Lubricate the pivot arms: refer to Lubrication,

page 11.

9. Touch up all rusted or chipped paint surfaces. Toro Re-Kote paint is available from an Authorized TORO Service Dealer.
10. Store mower in a clean, dry place, out of the reach of children. Cover mower to keep it clean and protected.

OPTIONAL EQUIPMENT

1. **Recycler Kit, Model No. 59173**—A Recycler Kit is available for commercial rear bagger mowers with serial numbers beginning with 1000001 and up. These kits must be installed **ONLY** by an Authorized Toro Service Dealer to ensure that the converted mower meets safety requirements.

2. **Spark Arrestor (Part No. 81-0200)**—If a spark arrestor is required because of local, state, or federal regulations, it may be purchased at your local Authorized TORO Service Dealer. Clean screen after every 75 hours of operation. If mower is operated on any California forest, brush, or grass covered land without a properly operating spark arrestor, the operator is violating state law, Section 4442 Public Resources Code.

TORO SERVICE SUPPORT

If help – concerning safety, set-up, operation, maintenance, or troubleshooting – is ever needed, contact the local Authorized TORO Service Dealer or Distributor. Refer to the “Yellow Pages” for assistance. In addition to skilled service technicians, the dealer and distributor have factory approved accessories and replacement parts. Keep your Toro all TORO. Buy genuine TORO replacement parts and accessories.

PRODUCT IDENTIFICATION

The model and serial number decal is located at rear of mower housing, near the discharge door. Always refer to specific numbers on this decal in correspondence or when replacement parts are needed.



The Toro Promise

A One Year Limited Warranty

The Toro Company promises to repair your TORO Product if defective in materials or workmanship. The following time periods from the date of purchase apply:

Commercial 21" Walk Power Mowers 1 Year

The cost of parts and labor are included, but the customer pays the transportation costs.

If you feel your TORO Product is defective and wish to rely on The Toro Promise, the following procedure is recommended:

1. Contact your Authorized TORO Distributor or Authorized Dealer (the Yellow Pages of your telephone directory is a good reference source).
2. The TORO Distributor or Authorized Dealer will advise you on the arrangements that can be made to inspect and repair your product.
3. The TORO Distributor or Authorized Dealer will inspect the product and advise you whether the product is defective, and if so, make all repairs necessary to correct the defect without an extra charge to you.

If for any reason you are dissatisfied with the distributor's analysis of the defect or the service performed, you may contact us.

Write: Consumer Products Service Dept.
8111 Lyndale Avenue South
Minneapolis, MN 55420

The above remedy of product defects through repair by an Authorized TORO Distributor or Authorized Dealer is the purchaser's sole remedy for any defect.

THERE IS NO OTHER EXPRESS WARRANTY. ALL IMPLIED WARRANTIES OF MERCHANTABILITY AND FITNESS FOR USE ARE LIMITED TO THE DURATION OF THE EXPRESS WARRANTY.

Some states do not allow limitations on how long implied warranty lasts, so the above limitation may not apply to you.

This Warranty applies only to parts or components which are defective and does not cover repairs necessary due to normal wear, misuse, accidents, or lack of proper maintenance. Regular, routine maintenance of the unit to keep it in proper operating condition is the responsibility of the owner.

All warranty repairs reimbursable under The Toro Promise must be performed by an Authorized Toro Dealer or Distributor using Toro approved replacement parts.

Repairs or attempted repairs by anyone other than an Authorized TORO Distributor or Authorized Dealer are not reimbursable under the TORO Promise. In addition, these unauthorized repair attempts may result in additional malfunctions, the correction of which is not covered by warranty.

THE TORO COMPANY IS NOT LIABLE FOR INDIRECT OR CONSEQUENTIAL DAMAGES IN CONNECTION WITH THE USE OF THE PRODUCT INCLUDING ANY COST OR EXPENSE OF PROVIDING SUBSTITUTE EQUIPMENT OR SERVICE DURING PERIODS OF MALFUNCTION OR NON-USE.

Some states do not allow the exclusion of incidental or consequential damages, so the above exclusion may not apply to you.

This warranty gives you specific legal rights, and you may also have other rights which vary from state to state.

COUNTRIES OTHER THAN THE UNITED STATES OR CANADA

Customers who have purchased TORO products exported from the United States or Canada should contact their TORO Distributor (Dealer) to obtain guarantee policies for your country, province, or state. If for any reason you are dissatisfied with your Distributor's service or have difficulty obtaining guarantee information, contact the TORO importer. If all other remedies fail, you may contact us at The Toro Company.