



MODEL NO. 58411-100001 &amp; UP

OPERATOR'S  
MANUAL

2 hp EDGER

**SAFETY INSTRUCTIONS**

This edger "meets or exceeds U.L. requirements for gasoline-powered edgers." However, improper use or maintenance by the operator or owner can result in injury. To reduce the potential for injury, comply with these safety instructions and always pay attention to the safety alert symbol  which means CAUTION, WARNING, OR DANGER — "personal safety instruction." Read and understand the instruction because it has to do with safety. Failure to comply with instruction may result in personal injury.

**BEFORE OPERATING**

1. Read this manual carefully before operating the edger. Become thoroughly familiar with the controls and proper use of the edger. Never allow children to operate the edger or adults to operate it without proper instructions. Know how to disengage controls and stop the unit quickly.
2. Keep everyone, especially children and pets, away from the area of operation. Thoroughly inspect area where edger will be used. Remove sticks, stones, wire, bones and any other debris because thrown objects can cause injury.
3. Dress properly by wearing long pants that cover legs, substantial footwear and safety glasses or goggles. Sturdy gloves and safety footwear are recommended. Do not wear loose clothing and jewelry because they could get caught in moving parts. Do not operate edger while wearing open sandals or when barefoot.
4. Check fuel level before starting engine. Do not fill fuel tank indoors, when the engine is running, or until engine cools for several minutes after running. If gasoline is spilled, move edger and gas can away from area and do not create a source of ignition. Wipe up spilled gasoline before starting engine. Always use an approved gas can.
5. Do not use edger unless all guards, shields, and safety devices are properly in place. Repair or replace defective or damaged parts, including decals, before using.
6. Disengage power to blade before starting engine. Ensure blade control functions properly before each use of the edger.

**WHILE OPERATING**

7. Do not run engine indoors because exhaust gases are dangerous.

8. Always maintain secure footing and balance. Keep both hands on handle and walk, never run. Never operate edger on gravel surfaces or steep slopes. Do not edge in the rain or wet locations. Edge only in daylight or in good artificial light.
9. Stay alert, use common sense, and always watch what you are doing. Do not operate edger when fatigued or under the influence of alcohol or drugs.
10. Use the edger for only the purpose described in this manual. Do not abuse the edger.
11. Keep face, hands and feet away from the cutter blade. Operate edger from position behind handle where guards block line of sight to blade.
12. Stay clear of discharge area. Never direct discharge of material toward bystanders nor allow anyone near area of operation. Avoid discharging material toward automobiles, glass enclosures and similar things.
13. Stay alert for uneven sidewalks, holes in terrain or other hidden hazards when using edger. Always push slowly over rough ground. When moving from place to place, disengage power to blade.
14. Since blade rotates for a few seconds after blade control is released, stay behind the handle until all moving parts stop.
15. After striking a foreign object or if edger vibrates abnormally, disengage power to blade, wait for blade to stop, and stop engine. Remove wire from spark plug and inspect for damage. Repair before using edger again.
16. Do not try to remove cut material or hold material to be cut when engine is running or when blade is rotating. Disengage power to blade, stop engine and disconnect wire from spark plug before clearing jammed material from cutter blade and belt area.

# SAFETY INSTRUCTIONS

17. Before leaving operator's position, disengage power to blade, wait for blade to stop, and stop engine. Disconnect wire from spark plug if edger will be unattended or not used.

18. Do not touch muffler or engine while it is running or shortly after it is stopped because muffler and engine may be hot enough to cause a burn.

19. Perform only those maintenance instructions described in this manual. If major repairs are ever needed or if assistance is desired, contact an Authorized TORO Service Dealer.

## MAINTENANCE

20. Before edger is cleaned, inspected, serviced, adjusted or transported, disengage power to blade and wait for blade to stop. Stop engine and disconnect wire from spark plug. Keep wire away from spark plug to prevent accidental starting.

21. To ensure edger is in safe operating condition, frequently check and keep all nuts, bolts, and screws properly tightened. Ensure blade nut is tightened to proper specification.

22. To reduce potential fire hazard, keep the engine area free of excessive grease, grass, leaves and accumulations of dirt.

23. Allow engine to cool before storing edger in any enclosure. Do not store edger near any open flame or where gasoline fumes may be ignited by a spark. Do not store edger in a car trunk or truck.

24. Do not overspeed the engine by changing governor settings.

25. When not in use, store edger in a dry place in an area that can be locked or is otherwise inaccessible to children.

26. At the time of manufacture, the edger conformed to the safety standards in effect for edgers. To ensure best performance and continued safety certification of the edger, use genuine TORO replacement parts and accessories. Replacement parts and accessories made by other manufacturers may result in non-conformance with the safety standards, and that could be dangerous.

# SAFETY DECALS AND INSTRUCTIONS

Safety decals and instructions are easily visible to the operator and are located near any area of potential danger. Replace any decal that is damaged or lost.

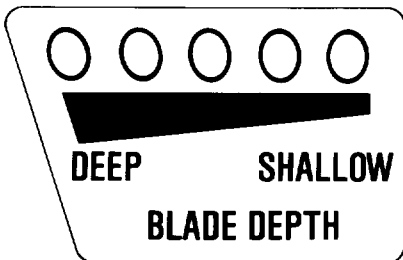

ON DEPTH ADJUSTMENT PLATE  
(Part No. 57-7420)



ON LOWER HANDLE  
(Part No. 68-7390)



ON BLADE GUARD  
(Part No. 68-7410)

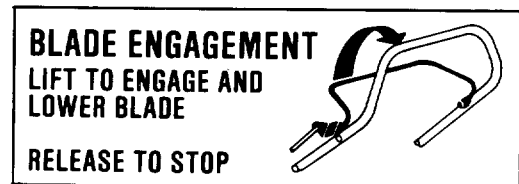

ON UPPER HANDLE  
(Part No. 57-7450)



ON AIR CLEANER  
(Part No. 63-8440)

# TABLE OF CONTENTS

	Page		Page
Set Up Instructions .....	3	Changing Oil .....	8
Before Operating .....	4	Cleaning and Lubricating Pivot Arm .....	8
Operating Instructions .....	5	Replacing Blade .....	9
Maintenance .....	7	Storage .....	9
Servicing Air Cleaner .....	7	Toro Service Support .....	9
Adjusting Carburetor .....	7	Product Identification .....	9
Draining Gasoline .....	8	Maintenance Interval Chart .....	10
Cleaning Cooling System .....	8	Maintenance Record .....	11
Replacing Spark Plug .....	8	The Toro Promise	

## SET UP INSTRUCTIONS

### INSTALL LOWER HANDLE (Fig. 1)

1. Pivot lower handle and handle latches rearward and align mounting holes. Secure handle latches to lower handle with (2) 5/16-18x3/4" lg. capscrews and locknuts. Tighten front latch screw and wheel nut.

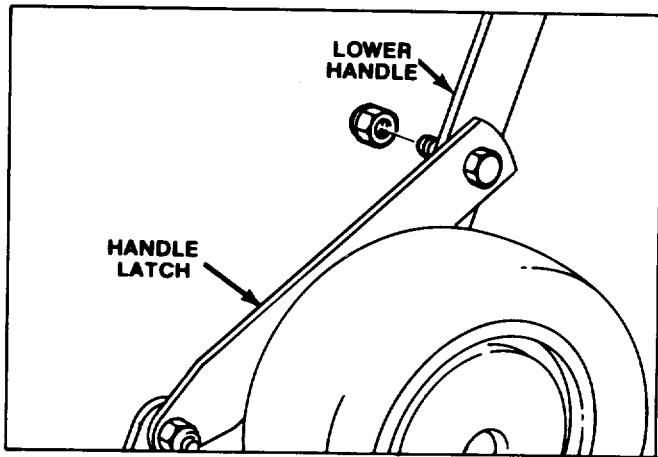

Figure 1

### INSTALL UPPER HANDLE (Fig. 2)

1. Align upper and lower handle mounting holes and secure each side with (2) 5/16-18x3/4" lg. capscrews and locknuts. Position depth adjustment assembly on left side of handle.

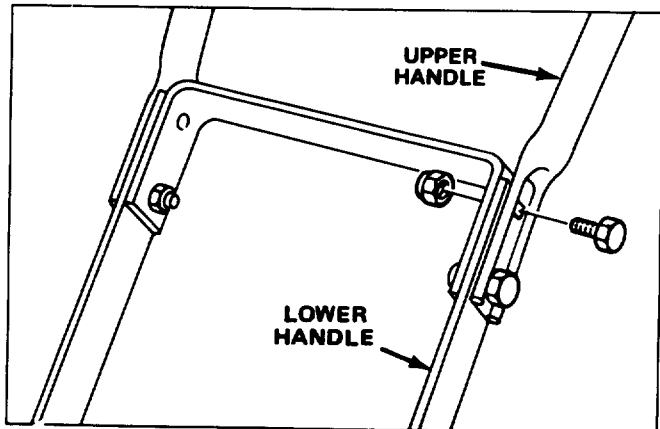

Figure 2

2. Slide air cleaner hose onto air cleaner cover opening and secure with tie strap.

### INSTALL DEPTH CONTROL ROD (Fig. 3 & 4)

1. Insert end of control rod with Z-bend into mounting hole in depth adjustment plate.

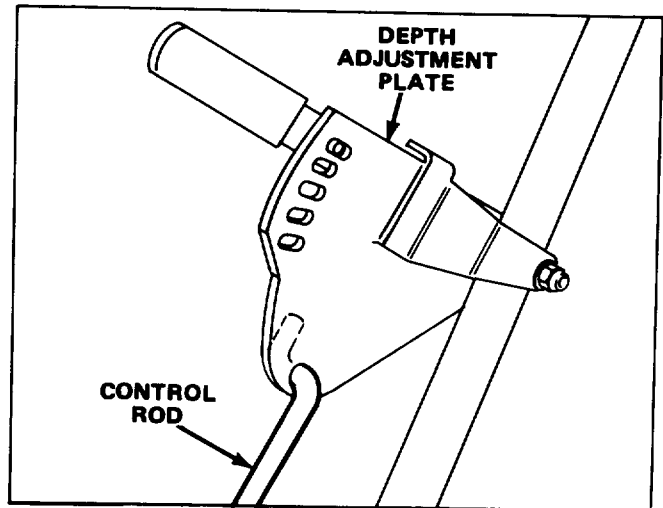

Figure 3

2. Insert other end of rod into pivot lever mounting hole and secure with washer and cotter pin.

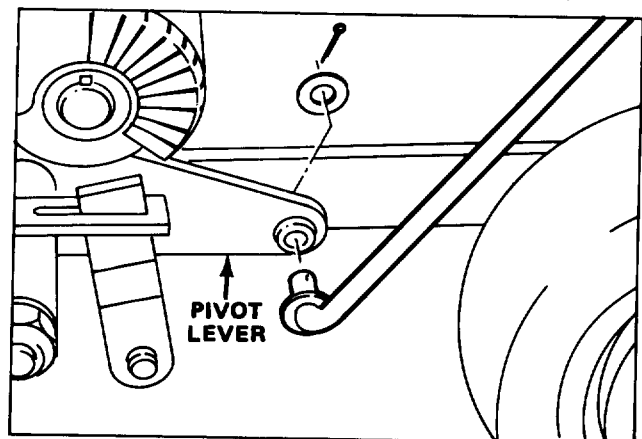

Figure 4



# OPERATING INSTRUCTIONS

## STARTING, STOPPING, EDGING

1. **CONTROLS**—Blade/clutch control bar is on upper handle (Fig. 6) and depth adjustment handle is on left side of upper handle (Fig. 10). Throttle, choke and stop switch are engine mounted (Fig. 7).

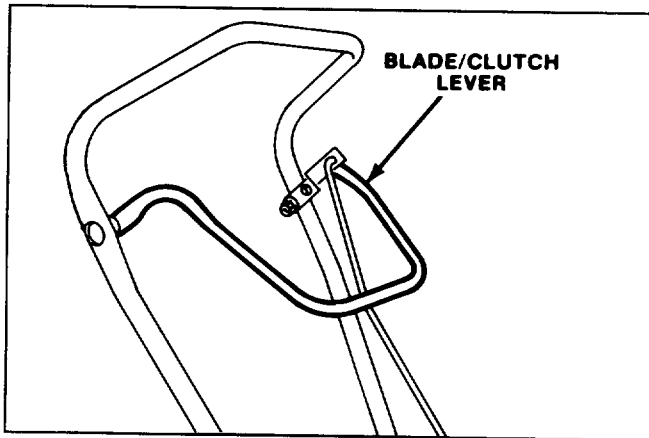

Figure 6

2. **STARTING**—Push wire onto spark plug and ensure blade control is disengaged. Push engine stop switch away from spark plug and make sure throttle is pulled out. Pull choke lever out to CHOKE position. A warm engine will require little or no choking. Place foot on rear wheel and pull recoil starter out slowly until positive engagement results; then pull vigorously until engine starts. When engine starts, gradually push choke lever to "RUN" position.

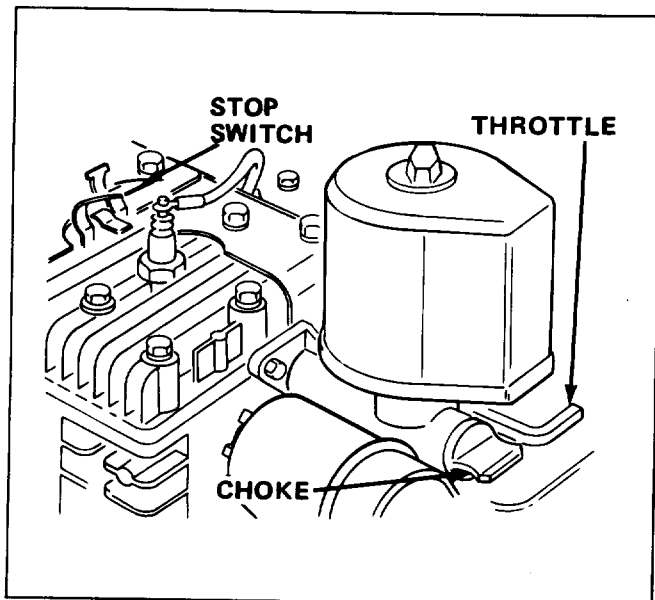

Figure 7

3. **EDGING**—Squeeze blade/clutch control bar (Fig. 6) against handle to engage blade and move

cutter to preset depth. Release blade/clutch control bar to disengage blade and raise cutter head.

4. **STOPPING**—Release blade/clutch control bar (Fig. 6) and push engine stop switch against spark plug.

## OPERATING TIPS

The Toro Edger puts the finishing touch on a beautiful lawn in minutes. Use it to edge along the walk, driveway, curb, flower bed and similar objects.

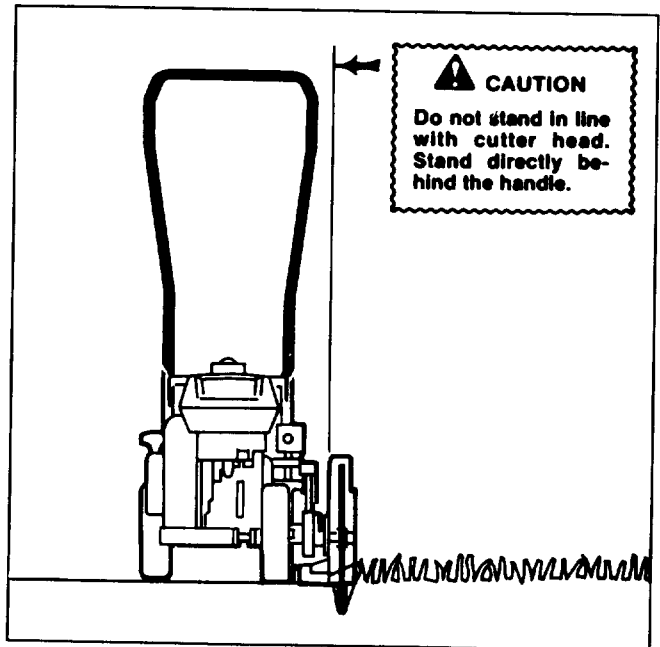

Figure 8

- For best results, adjust blade edging depth from 1/2 to 1 inch deep. Edging too deeply places an unnecessary load on the engine and causes premature blade wear. Not edging deeply enough allows grass to grow back sooner than normal. Be sure to adjust edging depth as blade wears.
- Do not force the edger. Move the edger ahead at moderate speeds.
- Best edging appearance will result when grass is dry. Do not edge wet grass. Wet grass may clog the blade and cause the lawn to take on an irregular edge. Also, you could slip and fall, and a body part could contact the edger blade.

## ADJUSTING EDGING DEPTH

1. Position edger on level surface and move blade to vertical position.
2. **CHECK EDGING DEPTH** (Fig. 9)—Squeeze blade/clutch lever against handle. Space between bottom of tire and ground is actual blade edging depth. If adjustment is required, go to step 3.

# OPERATING INSTRUCTIONS

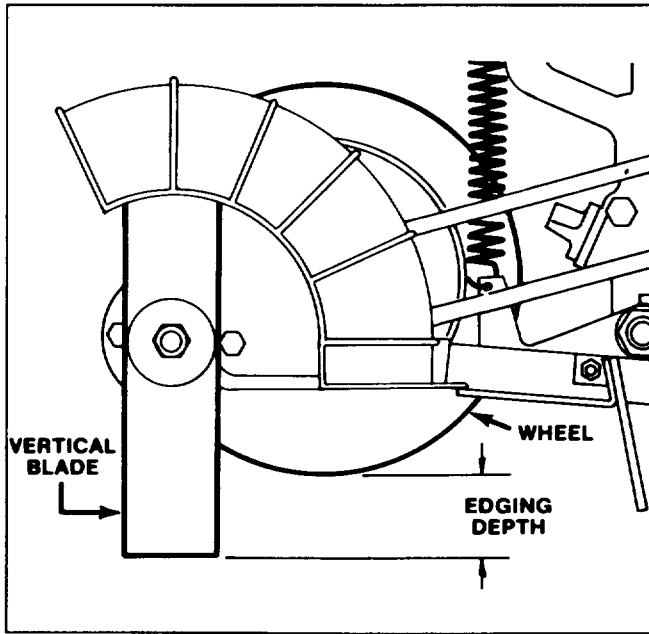

Figure 9

3. ADJUSTING DEPTH (Fig. 10)—Release blade/clutch control rod. Move depth adjustment handle forward to increase blade depth and rearward to decrease blade depth.

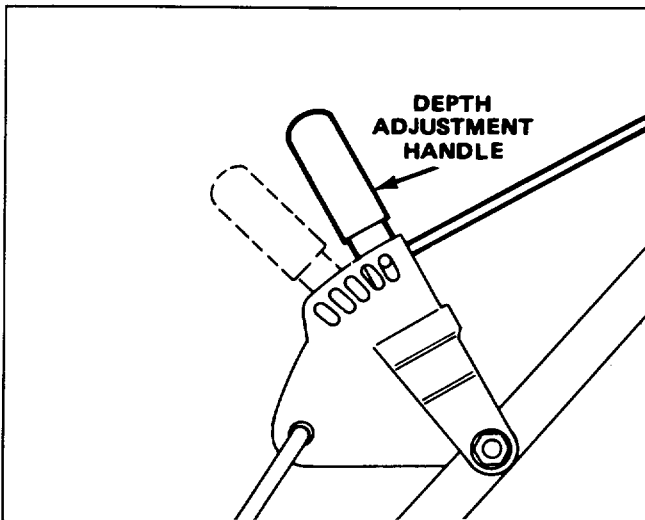

Figure 10

## ADJUSTING DROP WHEEL (Fig. 11)

The adjustable drop wheel lets you edge along curbs and similar object. Simply loosen the adjusting knob and slide the wheel assembly up or down until edger is level. Then tighten knob and start edging.

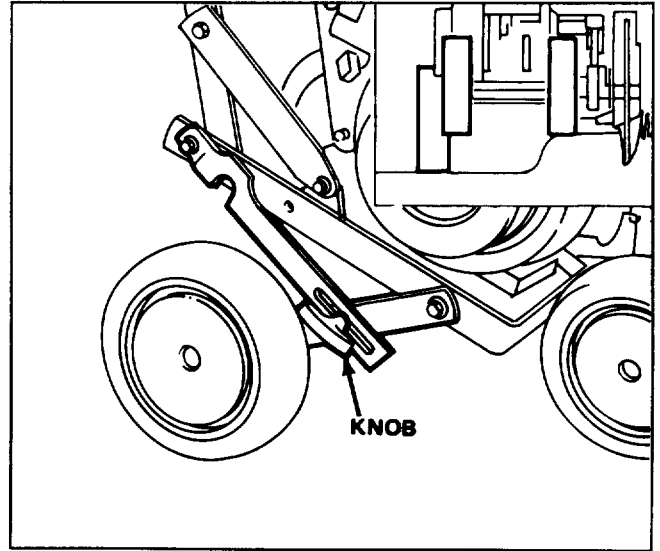

Figure 11

# MAINTENANCE



## CAUTION

Pull wire off spark plug before performing adjustments or maintenance. After engine is run, stay away from muffler and nearby engine areas because they could be hot enough to cause burns.

## SERVICING AIR CLEANER (Fig. 12)

Normally, clean and re-oil foam pre-cleaner after every 25 operating hours. More frequent cleaning is required when engine is operated in dusty or dirty conditions.

1. Stop engine and pull wire off spark plug.
2. Remove knob and air cleaner cover.

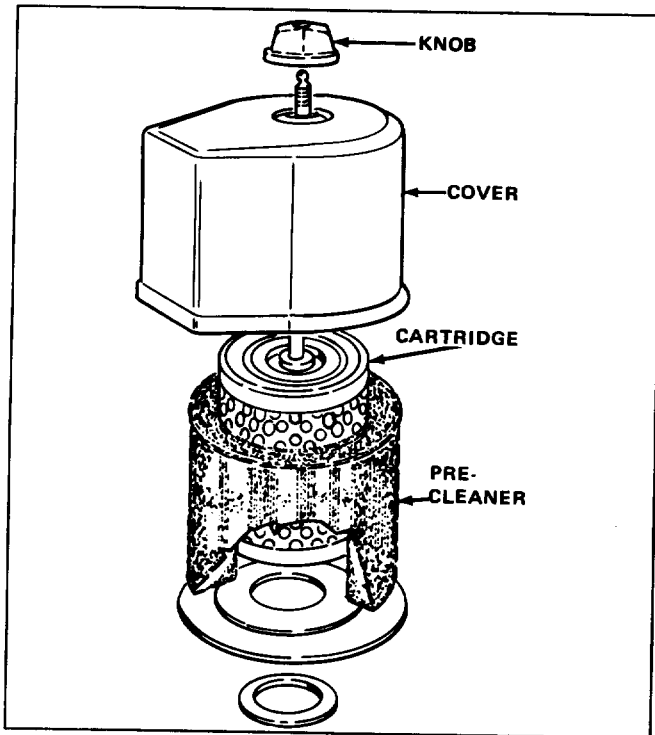

Figure 12

3. Slide foam pre-cleaner off paper cartridge.
4. A. Wash element in solution of liquid soap and warm water. Squeeze to remove dirt but do not twist because foam may tear. Rinse thoroughly with clear water.  
B. Dry by wrapping in a clean rag. Squeeze rag and foam element to dry.  
C. Saturate element with engine oil. Squeeze element to remove excess oil and to thoroughly distribute oil. A damp element is desirable.
5. Install foam pre-cleaner over paper cartridge.
6. Install air cleaner cover and spark plug wire.

Yearly or every 100 hours, whichever occurs first, remove paper cartridge. Clean by tapping gently

on flat surface. If very dirty, replace cartridge, or wash in a low or nonsudsing detergent and warm water solution. Rinse thoroughly with flowing water from inside out until water is clear. Cartridge must be allowed to stand and air dry thoroughly before using. Service more often if necessary.

**IMPORTANT:** Do not operate engine without air cleaner element because extreme engine wear and damage will likely result.

## ADJUSTING CARBURETOR (Fig. 13)

The carburetor has been adjusted at the factory, but an adjustment may be required to compensate for difference in fuel, temperature or altitude.

**Note:** If a carburetor adjustment is required, fill fuel tank 1/2 full with gasoline. The air cleaner must be assembled to carburetor when running engine.

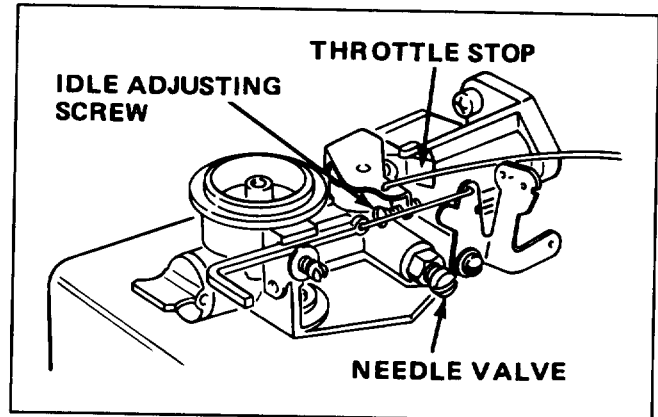

Figure 13

1. INITIAL SETTING—Proper setting for needle valve is 1-1/2 turns open, and one turn open for idle valve. These settings should allow engine to be started. To adjust screws, gently rotate screw in (clockwise) until slight seating resistance is felt. DO NOT OVERTIGHTEN SCREWS BECAUSE CARBURETOR WILL BE DAMAGED. Then rotate screw out (counterclockwise) to the prescribed setting.
2. FINE TUNING—Start engine and let it run for 5 minutes. Turn needle valve in (clockwise) until engine slows (lean mixture). Then turn it out past smooth operating point (rich mixture). Now turn needle valve to the midpoint between rich and lean. Next, adjust idle RPM. Rotate throttle counterclockwise and hold against stop while adjusting idle speed screw to obtain 1750 RPM. Hold throttle against stop while turning idle valve in (lean) and out (rich). Set at midpoint between rich and lean. Recheck idle RPM. Release throttle. If engine will not accelerate properly, the carburetor may have to be readjusted, usually to a slightly richer mixture.

# MAINTENANCE

## DRAINING GASOLINE

1. Stop engine and pull wire off spark plug.
2. Remove cap from gas tank and use pump-type syphon to drain fuel into clean gas can.

**Note:** This is the only procedure recommended for draining fuel.

3. Reinstall spark plug wire.

## CLEANING COOLING SYSTEM

After every 75 operating hours (more frequently when dusty or dirty), clean dirt and chaff from cylinder, cylinder head fins and from around carburetor and linkage. Also remove debris from air intake slots on recoil housing. This will ensure proper cooling and best engine performance.

## REPLACING SPARK PLUG (Fig. 14)

Use a CHAMPION CJ-8 spark plug or equivalent. Correct air gap is 0.030" (0.76 mm). Remove plug after every 25 operating hours and check its condition.

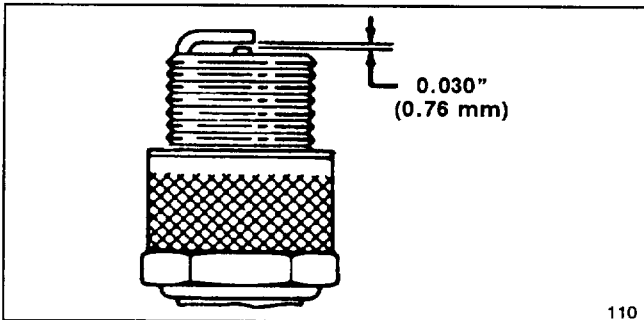

Figure 14

1. Stop engine and pull wire off spark plug.
2. Clean around spark plug and remove plug from cylinder head.

**IMPORTANT:** Replace a cracked, fouled or dirty spark plug. Do not sand blast, scrape or clean electrodes because engine damage could result from grit entering cylinder.

3. Set air gap. Install correctly gapped spark plug and gasket seal. Tighten plug firmly.

## CHANGING OIL (Fig. 15)

Change oil after the first 2 operating hours and every 25 hours thereafter. Since warm oil drains better and carries more contaminants than cold oil, run engine for a minute or so before draining oil.

1. Stop engine and pull wire off spark plug.

2. Drain gasoline: refer to Draining Gasoline, page 8.

3. While holding front of edger up slightly, remove oil fill and drain plugs (Fig. 15). Slowly tip forward and empty all oil into drain pan. Tip up and down several times to ensure oil drains completely.

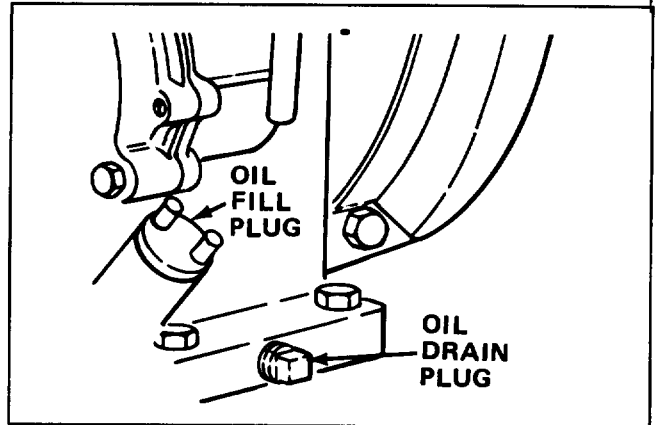

Figure 15

4. Reinstall oil drain plug and tighten firmly. Fill oil sump with proper oil: refer to Fill Crankcase With Oil, page 4.

5. Reinstall spark plug wire.

## CLEANING AND LUBRICATING PIVOT ARM (Fig. 16)

After every 25 operating hours, more often in dusty or dirty conditions, clean entire pivot arm assembly and lubricate it with #2 general purpose grease.

1. Clean grease fittings and surrounding areas.
2. Continue to apply grease until noticeable amount overflows. This helps force dirt out of pivot assembly.

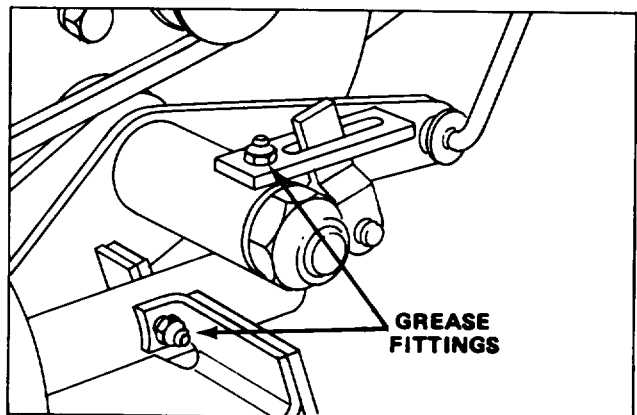

Figure 16

# MAINTENANCE

## REPLACING BLADE (Fig. 17)

The edger has a 9 inch blade that gradually wears because of use. Replace blade if it wears down to 5 inches or less.

1. Stop engine and pull wire off spark plug.
2. Using a 1-1/4 inch wrench, hold squared bearing shield and remove blade nut and washer. Slide blade and washer off spindle.
3. Install new blade, existing washers and blade nut in sequence shown. Tighten nut to 40-60 ft-lb.

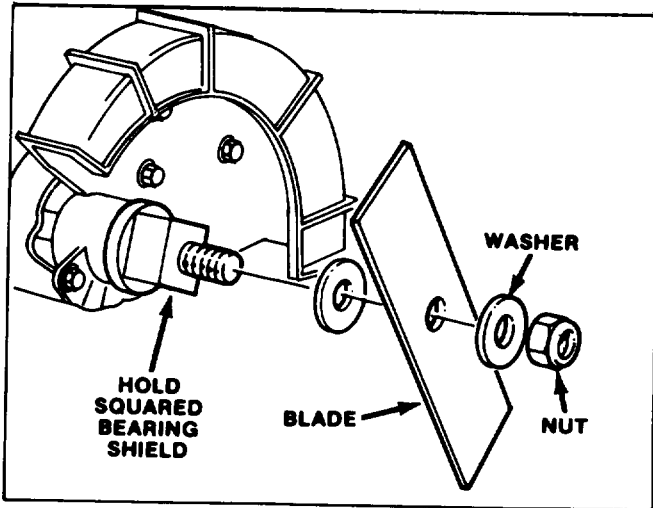

Figure 17

## STORAGE

1. For long term storage, either drain gasoline from fuel tank or add a fuel stabilizer to the gasoline. To drain gasoline, refer to Draining Gasoline, page 8. After fuel is drained, start engine and let it idle until all fuel is consumed and engine stops. Repeat the starting procedure two more times to assure all gas is removed from the engine. If gas-

oline is not drained, gum-like varnish deposits will form and cause poor engine operation, even starting problems.

Fuel can be left in gas tank only if a fuel additive, such as Toro's Stabilizer/Conditioner, is added to gasoline and run through engine before storing. Toro's Stabilizer/Conditioner is a petroleum distillate based conditioner/stabilizer. Toro does not recommend stabilizers with an alcohol base, such as ethanol, methanol or isopropyl. Use fuel additive in recommended quantities as specified on container.

Under normal conditions, all fuel additives remain effective in fuel for 6-8 months.

2. Drain oil and refill with fresh oil: refer to Changing Oil, page 8. After oil is drained, do not fill crankcase until steps 3-9 are completed.
3. Clean air cleaner: refer to Servicing Air Cleaner, page 7.
4. Clean dirt and chaff from cylinder, cylinder head fins and blower housing. Also remove grass clippings, dirt and grime from external parts of the engine and shrouding. Clean entire edger thoroughly.
5. Clean and lubricate pivot arm assembly: refer to Cleaning and Lubricating Pivot Arm, page 8.
6. Inspect edger blade for wear or other visible damage: refer to Replacing Blade, page 9.
7. Tighten all nuts, bolts and screws.
8. Touch up all rusted or chipped paint surfaces. Toro Re-Kote paint is available from an Authorized TORO Service Dealer.
9. Gently pull recoil starter until a drag is felt. This is done to close the valve.
10. Store edger in a clean, dry place. Cover edger to keep it clean and protected.

## TORO SERVICE SUPPORT

If help - concerning safety, set-up, operation and maintenance or troubleshooting - is ever needed, contact the local Authorized TORO Service Dealer or Distributor. Refer to the "Yellow Pages" for assistance. In addition to skilled service technicians, the dealer and distributor have factory approved accessories and replacement parts. Keep your Toro all TORO. Buy genuine TORO replacement parts and accessories.

## PRODUCT IDENTIFICATION

A model number and a serial number decal is located on the lower handle. Always refer to specific numbers on this decal in correspondence or when replacement parts are needed.

# MAINTENANCE INTERVAL CHART

Service Procedure	Before Each Use	After First 2 Hours	Every 25 Hours	Every 50 Hours	Every 75 Hours
Check Oil	X				
Check Blade	X				
Lubricate Wheel Bearings			X		
Lubricate Pivot Arm			X		
Check and Gap Spark Plug			X		
Service Air Cleaner*			X		
Change Oil		X	X		
Clean Cooling System					X

\*Service more frequently when conditions are dusty or sandy.



**The Toro Promise**  
**A Two Year Limited Warranty**  
**On All**  
**Gasoline Powered Consumer Products**

*The Toro Company promises to repair these TORO Products if defective in materials or workmanship. The following time periods from the date of purchase apply:*

Residential Product .....	2 Years
Residential Products Used Commercially .....	45 Days
Straight Shaft Trimmers, 3 H.P. Edger, Back Pack Blowers, 5 H.P. Lawn Vac, 5 H.P. Blower Used Commercially .....	90 Days

*The cost of parts and labor are included, but the customer pays the transportation costs. Just return any residential product to an Authorized TORO Service Dealer or TORO Distributor.*

Should you feel your TORO Product is defective and wish to rely on The Toro Promise, the following procedure is recommended:

1. Contact any Authorized TORO Service Dealer, TORO Master Service Dealer, or TORO Distributor (the Yellow Pages of your telephone directory is a good reference source).
2. He will either instruct you to return the product to him or recommend another Authorized TORO Service outlet which might be more convenient.
3. Bring the product along with your original sales slip, or other evidence of purchase date, to the service dealer.
4. The servicing dealer will inspect the unit, advise you whether the product is defective and, if so, make all repairs necessary to correct the defect without extra charge to you.

If for any reason you are dissatisfied with the analysis of the defect or the service performed, you may contact us.

Write: TORO Customer Service Dept.  
8111 Lyndale Avenue South  
Minneapolis, MN 55420

The above remedy of product defects through repair by an Authorized TORO Service Dealer is the purchaser's sole remedy for any defect.

**THERE IS NO OTHER EXPRESS WARRANTY EXCEPT FOR THE TORO STARTING GUARANTEE ON GTS ENGINES. ALL IMPLIED**

**WARRANTIES OF MERCHANTABILITY AND FITNESS FOR USE ARE LIMITED TO THE DURATION OF THE EXPRESS WARRANTY.**

Some states do not allow limitations on how long implied warranty lasts, so the above limitation may not apply to you.

This Warranty applies only to parts or components which are defective and does not cover repairs necessary due to normal wear, misuse, accidents, or lack of proper maintenance. Regular, routine maintenance of the unit to keep it in proper operating condition is the responsibility of the owner.

All warranty repairs reimbursable under The Toro Promise must be performed by an Authorized Toro Service Dealer using Toro approved replacement parts.

Repairs or attempted repairs by anyone other than an Authorized TORO Service Dealer are not reimbursable under the TORO Promise. In addition, these unauthorized repair attempts may result in additional malfunctions, the correction of which is not covered by warranty.

THE TORO COMPANY IS NOT LIABLE FOR INDIRECT OR CONSEQUENTIAL DAMAGES IN CONNECTION WITH THE USE OF THE PRODUCT INCLUDING ANY COST OR EXPENSE OF PROVIDING SUBSTITUTE EQUIPMENT OR SERVICE DURING PERIODS OF MALFUNCTION OR NON-USE.

Some states do not allow the exclusion of incidental or consequential damages, so the above exclusion may not apply to you.

This warranty gives you specific legal rights, and you may also have other rights which vary from state to state.

**COUNTRIES OTHER THAN THE UNITED STATES OR CANADA**

Customers who have purchased TORO products exported from the United States or Canada should contact their TORO Distributor (Dealer) to obtain guarantee policies for your country, province, or state. If for any reason you are dissatisfied with your Distributor's service or have difficulty obtaining guarantee information, contact the TORO Importer. If all other remedies fail, you may contact us at The Toro Company.