



# Road Light and Homologation/Brake and Signal Kits

## Workman® MD Series Utility Vehicles

Model No. 120-5031

Model No. 120-5044

### Installation Instructions

## Loose Parts

Use the chart below to verify that all parts have been shipped.

Procedure	Description	Qty.	Use
<b>1</b>	No parts required	–	Prepare the machine.
<b>2</b>	No parts required	–	Drill the holes for the front signal lights.
<b>3</b>	Brake switch Screw, #6 Locknut, #6	1 2 2	Install the brake switch.
<b>4</b>	Front wiring harness	1	Install the front wiring harness.
<b>5</b>	Signal light Signal-light bracket, left Signal-light bracket, right Hex nut (M5 X 0.88 MM) — Supplied on light assembly Lock washer (M5) — Supplied on light assembly Locknut (1/4-20 inch) Bolt (1/4 x 3/4 inch)	2 1 1 4 4 4 4	Install the signal lights.
<b>6</b>	Column bracket Flasher module Screw (#10-24 x 1/2 inch) Locknut Signal-indicator light Signal-lever switch Hazard switch Speed nut Plug Column-mount bracket Carriage screw Flange nut Column cover	1 1 3 1 1 1 1 2 1 1 2 2 1	Install the signal controller.



Procedure	Description	Qty.	Use
<b>7</b>	Plate bracket	1	Install the plate bracket.
	Screw (#10-3/4 inch) (2013 and older models)	2	
	Wiring harness	1	
	Plate light	2	
	Screw (10-24 x 5/8 inch)	4	
	Lock nut	4	
	Push clip (2014 and newer models)	5	
<b>8</b>	Light bracket	2	Install the tail lights.
	Screw (#10-3/4 inch) (2013 and older models)	4	
	Tail light	2	
	Cable-tie clip (2013 and older models)	2	
	Cable tie	2	
	Flange-head bolt (2014 and newer models)	2	
<b>9</b>	Rear wiring harness	1	Install the rear wiring harness.
	Cable-tie clip	2	
	Cable tie	1	
<b>10</b>	Lanyard kit 119-9590 (sold separately)	1	Install the lanyard.

# 1

## Preparing the Machine

**No Parts Required**

### Procedure

#### **⚠ CAUTION**

If you leave the key in the ignition switch, someone could accidentally start the engine and seriously injure you or other bystanders.

Remove the key from the ignition switch before you do any maintenance.

1. Position the machine on a level surface.
2. Set the parking brake, turn the ignition off, and remove the key.
3. On the passenger side of the machine, locate the battery and disconnect the negative battery cable.

# 2

## Drilling the Holes for the Front Signal Lights

**No Parts Required**

### Procedure

1. Measure and drill the holes in the front fenders at the locations shown in Figure 1.

# 3

## Installing the Brake Switch

### Parts needed for this procedure:

1	Brake switch
2	Screw, #6
2	Locknut, #6

### Procedure

1. Install the brake switch to the pedal assembly using 2 #6 screws and locknuts (Figure 3).

**Note:** The MDX-D is already equipped with a brake switch. Stack the new brake switch on top of the existing switch.

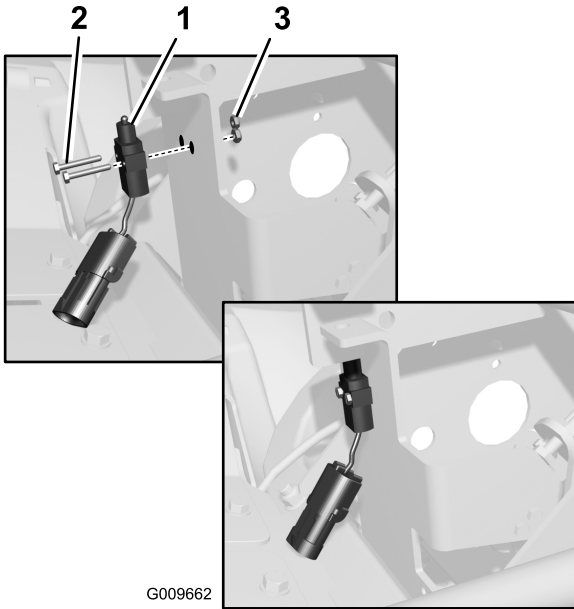

Figure 3

1. Brake switch
2. Bolts, #6
3. Locknuts, #6

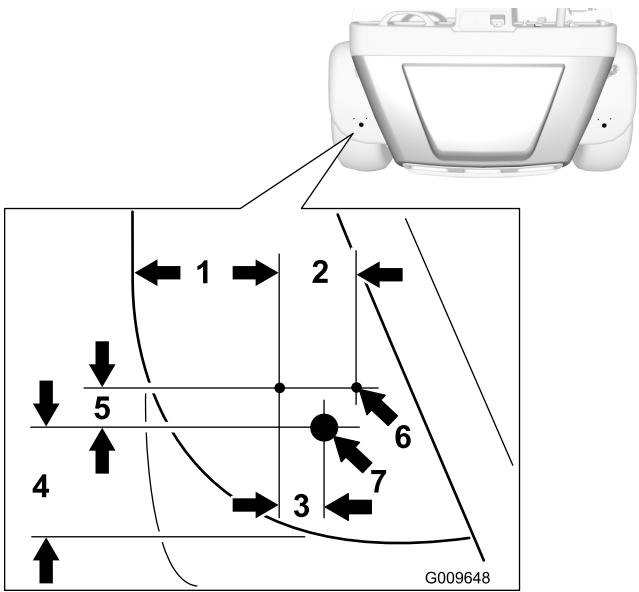

Figure 1

Left side shown

1. 12.40 cm (4.88 inch)
2. 5.72 cm (2.25 inch)
3. 2.54 cm (1.00 inch)
4. 8.26 cm (3.25 inch)
5. 4.19 cm (1.65 inch)
6. 7 mm (0.28 inch) diameter hole
7. 4.14 cm (1.63 inch) diameter hole

2. Raise the hood. Measure and drill the holes to receive the plastic anchors in the wiring harness (Figure 2).

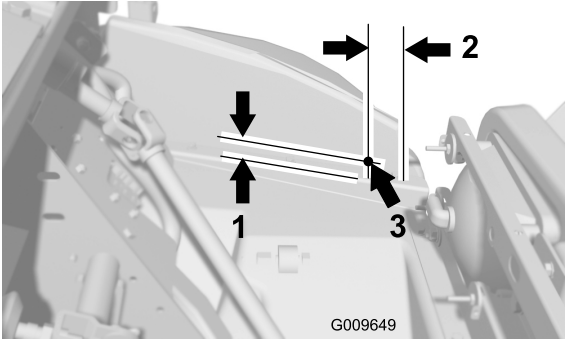

Figure 2

Left side shown

1. 6 mm (0.25 inch)
2. 6.35 cm (2.50 inch)
3. 7 mm (0.27 inch) diameter hole

# 4

## Installing the Front Wiring Harness

### Parts needed for this procedure:

1	Front wiring harness
---	----------------------

### Front Wiring Harness Overview

Locate the front wiring harness in loose parts. Use Figure 4 to identify the connectors.

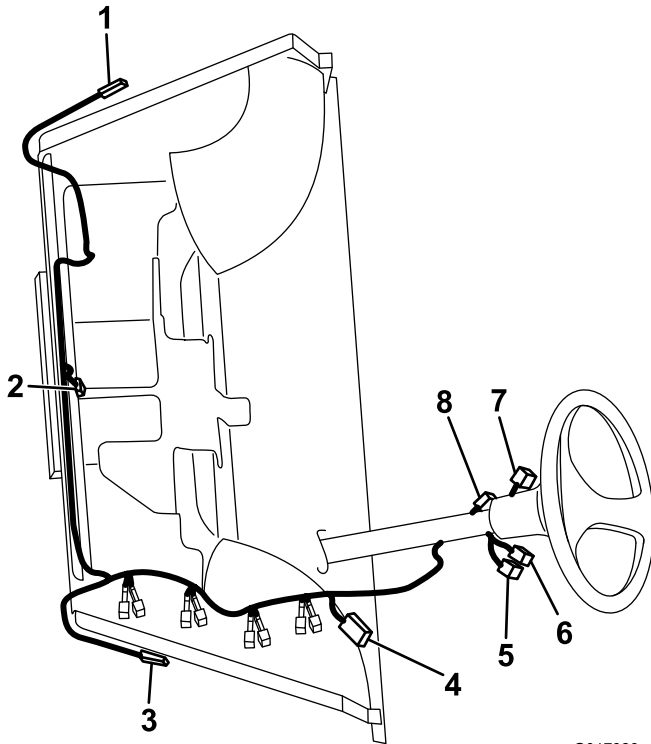

Figure 4

G017828

- |                            |                           |
|----------------------------|---------------------------|
| 1. Right-turn-signal light | 5. Signal-lever switch    |
| 2. Brake switch            | 6. Signal-indicator light |
| 3. Left-turn-signal light  | 7. Hazard switch          |
| 4. Main wiring harness     | 8. Flasher module         |

## Connecting to the Main Wiring Harness

1. Locate the main wiring harness and the open connector labeled Brake and Signal Light Kit.
2. Connect the front wiring harness from the kit to the main wiring harness at the labeled connector.

**Note:** The connectors are 6-pin, 3 over 3.

3. Lay the remainder of the wiring harness out in the front bay of the vehicle.

## Connecting to the Brake Switch

1. Locate the brake switch connector on the front wiring harness.
2. Connect the front wiring harness to the brake switch installed previously.
3. Route the signal connectors across the front frame along with the existing harness for the head lights.

**Note:** Make sure the length of the harness extending from the brake switch connector and terminating in the 3-pin signal connector is routed to the right front of the compartment.

Secure the wiring harness to the existing main vehicle harness and along the frame with plastic ties.

# 5

## Installing the Signal Lights

### Parts needed for this procedure:

2	Signal light
1	Signal-light bracket, left
1	Signal-light bracket, right
4	Hex nut (M5 X 0.88 MM) — Supplied on light assembly
4	Lock washer (M5) — Supplied on light assembly
4	Locknut (1/4-20 inch)
4	Bolt (1/4 x 3/4 inch)

### Assembling the Signal Lights

1. Locate the 2 signal lights in loose parts. They can be identified by having clear and amber lamps.
2. Locate the left and right signal light brackets.

**Note:** The brackets are distinguishable by angle of the face plate and a longer standing leg that will always be outboard (Figure 5).

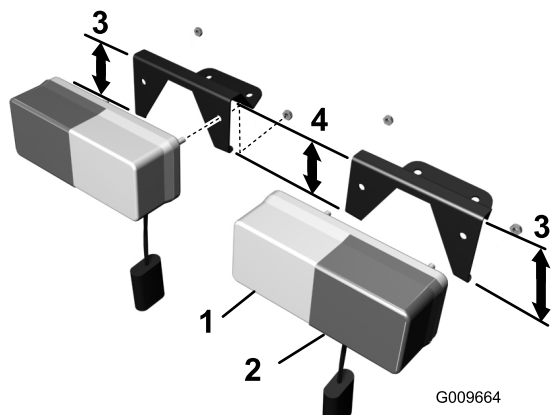

**Figure 5**

- |                       |   |
|-----------------------|---|
| 1. Clear lamp         | 4. Shorter bracket leg                                |
| 2. Amber lamp         | 5. Hex nut (M5 X 0.88 MM), supplied on light assembly |
| 3. Longer bracket leg | 6. Lock washer (M5), supplied on light assembly       |

- 
- Match each signal light to the corresponding bracket so that the amber (signal) lamp is always outboard (Figure 5).
  - Secure a light to each bracket with 2 hex nuts (M5 X 0.88 MM) and 2 lock washers (M5) supplied on the light assembly

## Installing the Signal Lights

- Install the left-signal-light assembly to the left front fender at the holes drilled previously (Figure 6).

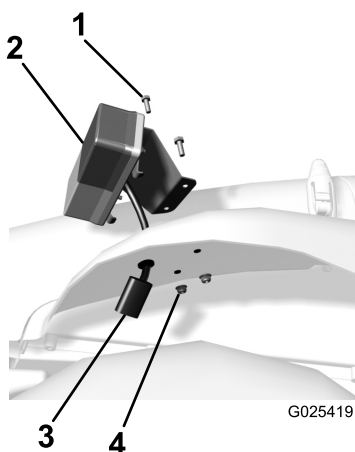

**Figure 6**

Left side shown

- |                                |                       |
|--------------------------------|-----------------------|
| 1. Bolt (1/4 x -20 x 3/4 inch) | 3. Connector          |
| 2. Left-signal-light assembly  | 4. Locknut (1/4 inch) |

- 
- Feed the connector through the large hole.
  - Align the holes in the bracket with the smaller drilled holes in the fender.
  - Secure the assembly to the fender with 2 bolts (1/4 x -20 x 3/4 inch) and 2 locknuts (1/4 inch)

- Locate the left, 3-pin connector for the left-signal light on the front wiring harness previously installed.
- Route the connector under the front fender, and secure the connector to the underside of the fender with the plastic anchor on the harness (Figure 7)

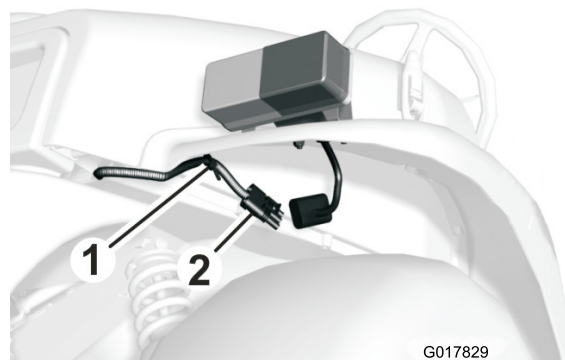

**Figure 7**

- |                   |                                |
|-------------------|--------------------------------|
| 1. Plastic anchor | 2. Left-signal-light connector |
|-------------------|--------------------------------|

- 
- Connect the left signal light to the harness.

Repeat this procedure for the right-signal-light assembly.

# 6

## Installing the Signal Controller

### Parts needed for this procedure:

1	Column bracket
1	Flasher module
3	Screw (#10-24 x 1/2 inch)
1	Locknut
1	Signal-indicator light
1	Signal-lever switch
1	Hazard switch
2	Speed nut
1	Plug
1	Column-mount bracket
2	Carriage screw
2	Flange nut
1	Column cover

### Procedure

1. Mount the flasher module to the column bracket with a screw (#10-24 x 1/2 inch) and a locknut (Figure 8).

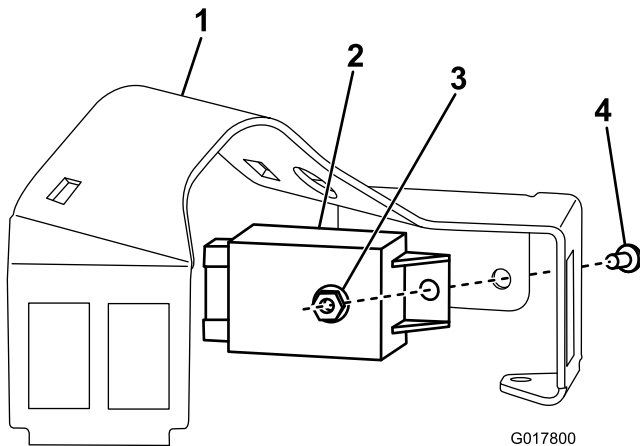

**Figure 8**

- |                   |                              |
|-------------------|------------------------------|
| 1. Column bracket | 3. Locknut                   |
| 2. Flasher module | 4. Screw (#10-24 x 1/2 inch) |

2. Install the signal-indicator light in the column bracket (Figure 9).

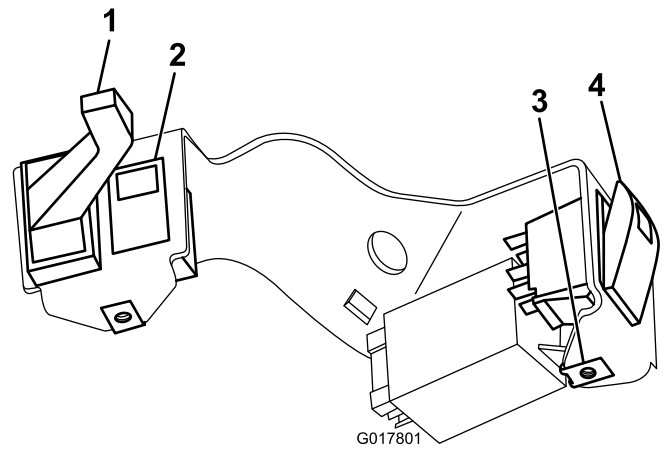

**Figure 9**

- |                           |                  |
|---------------------------|------------------|
| 1. Signal-lever switch    | 3. Speed nut     |
| 2. Signal-indicator light | 4. Hazard switch |

3. Install the signal lever switch and hazard switch in the column bracket (Figure 9).
4. Slide the speed nuts onto the column bracket (Figure 9).
5. Push the plug into the hole on top of the column bracket (Figure 10).

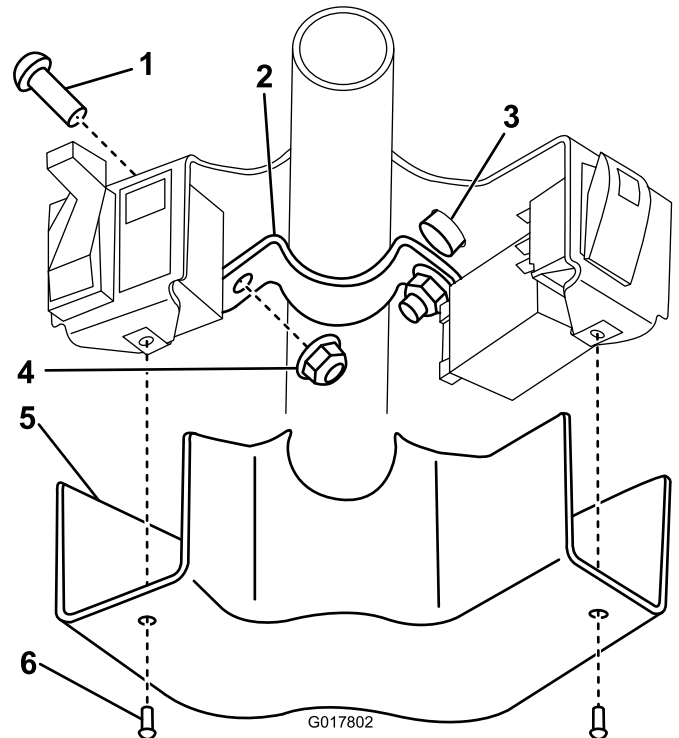

**Figure 10**

- |                         |                              |
|-------------------------|------------------------------|
| 1. Carriage screw       | 4. Flange nut                |
| 2. Column-mount bracket | 5. Column cover              |
| 3. Plug                 | 6. Screw (#10-24 x 1/2 inch) |

6. Install the assembly on the steering column using the column mount bracket, 2 carriage screws, and 2 flange nuts (Figure 10).

7. Connect the wiring harness to the signal-indicator light, signal and hazard switches, and flasher module.
8. Install the column cover with the 2 remaining screws (#10-24 x 1/2 inch) (Figure 10).

# 7

## Installing the Plate Bracket (Model 120-5031 only)

### Parts needed for this procedure:

1	Plate bracket
2	Screw (#10-3/4 inch) (2013 and older models)
1	Wiring harness
2	Plate light
4	Screw (10-24 x 5/8 inch)
4	Lock nut
5	Push clip (2014 and newer models)

### For 2013 and Older Models

1. Install the plate bracket to the underside of the bed with 2 screws (#10-3/4 inch) (Figure 11).

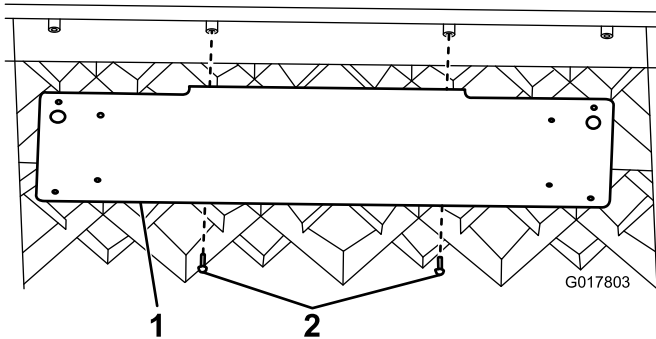

**Figure 11**

1. Plate bracket
2. Screws (#10-3/4 inch)

2. Install the wiring harness by attaching the clips to the underside of the box (Figure 12).

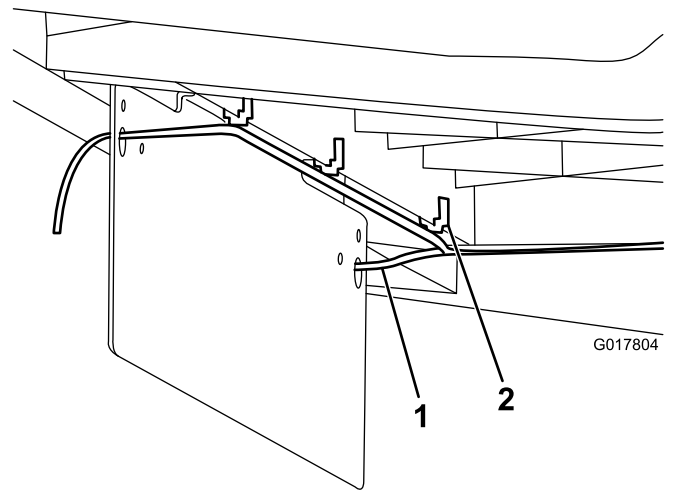

**Figure 12**

1. Wiring harness
2. Wiring harness clips

3. Insert the wires through the large holes in the plate bracket (Figure 12).
4. Connect the wires to the 2 plate lights.
5. Mount the 2 plate lights to the plate bracket with the remaining screws (10-24 x 5/8 inch) and locknuts (Figure 15).

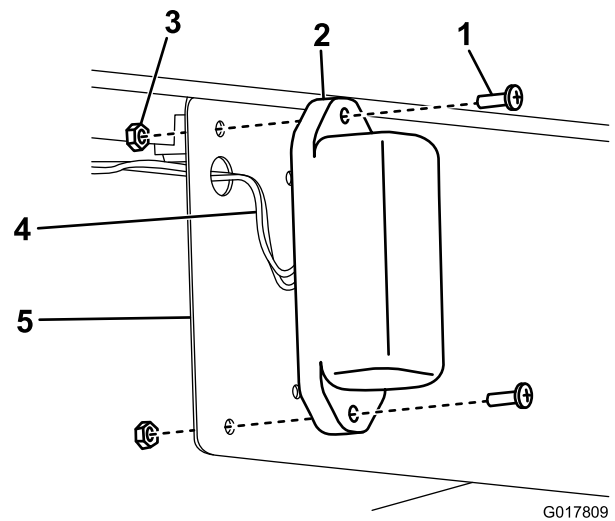
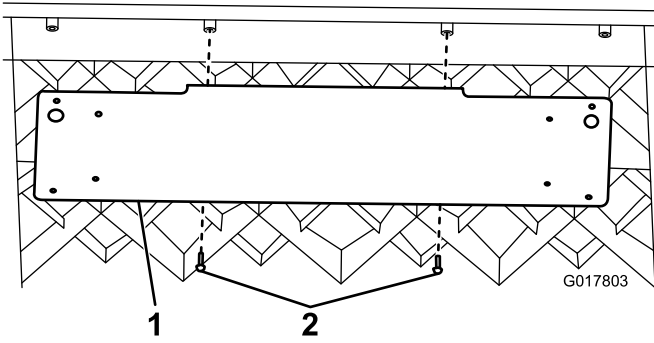

**Figure 13**

1. Screw (10-24 x 5/8 inch)
2. Plate light
3. Locknut
4. Wiring harness
5. Plate bracket

## For 2014 and Newer Models

1. Install the plate bracket to the underside of the bed with the 2 existing flange-head bolts (Figure 14).



**Figure 14**

1. Plate bracket
2. Flange-head bolts

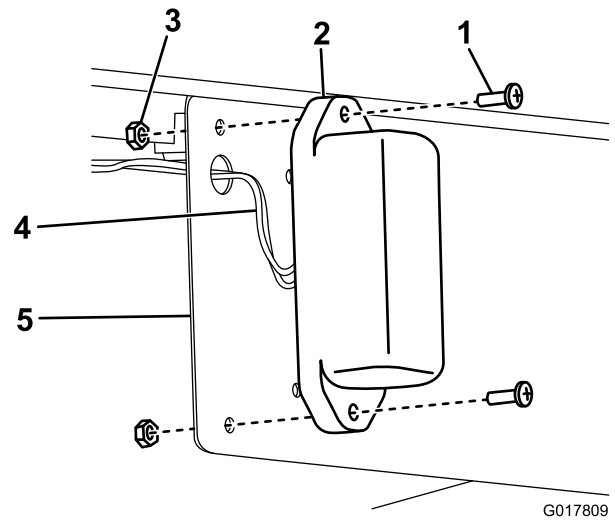
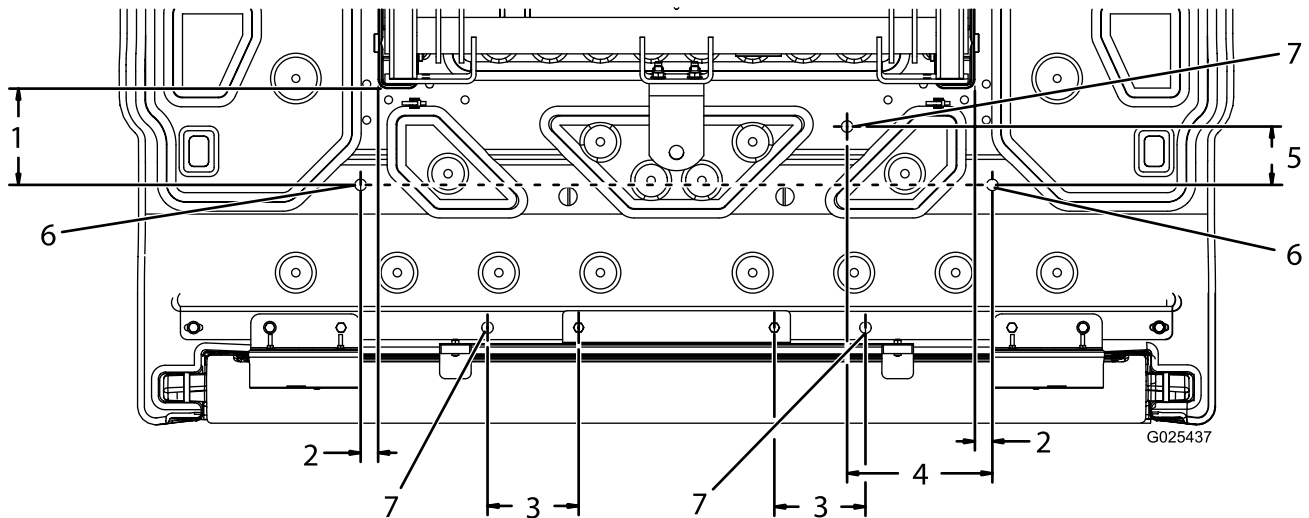

**Figure 15**

1. Screw (10-24 x 5/8 inch)
2. Plate light
3. Locknut
4. Wiring harness
5. Plate bracket

2. Remove the 4 existing wiring harness clips from the wiring harness.
3. Drill 5 6 mm (1/4 inch) holes as shown in Figure 16.
4. Insert the 5 push clips into the new holes.
5. Secure the wiring harness to the 3 wiring harness clips using the attached cable ties (Figure 16).
6. Insert the wires through the large holes in the plate bracket (Figure 15).

7. Connect the wires to the 2 plate lights.
8. Mount the 2 plate lights to the plate bracket with the remaining screws (10-24 x 5/8 inch) and locknuts (Figure 15).



**Figure 16**

Shown from underneath

1. 13.43 cm (5.29 inches)
2. 2.43 cm (0.96 inches)
3. 12.70 cm (5.00 inches)
4. 20.24 cm (7.97 inches)
5. 8.12 cm (3.20 inches)
6. Push clips (for tail lights)
7. Push clips (for wiring harness)

# 8

## Installing the Tail Lights

### Parts needed for this procedure:

2	Light bracket
4	Screw (#10-3/4 inch) (2013 and older models)
2	Tail light
2	Cable-tie clip (2013 and older models)
2	Cable tie
2	Flange-head bolt (2014 and newer models)

### Procedure

1. Install each light bracket to the bed.
  - For 2013 and older models, secure the brackets with 2 #10-3/4 inch screws (Figure 17).

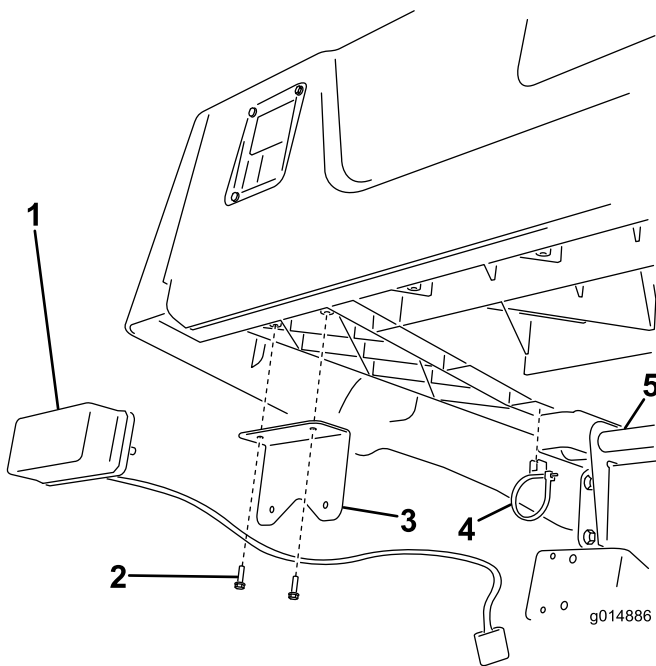

**Figure 17**

- |                         |   |
|-------------------------|---|
| 1. Tail light           | 4. Cable-tie clip                         |
| 2. Screw (#10-3/4 inch) | 5. Bed pivot tube (secure the cable here) |
| 3. Light bracket        |   |

- For 2014 and newer models, secure the brackets with 2 flange-head bolts (Figure 18).

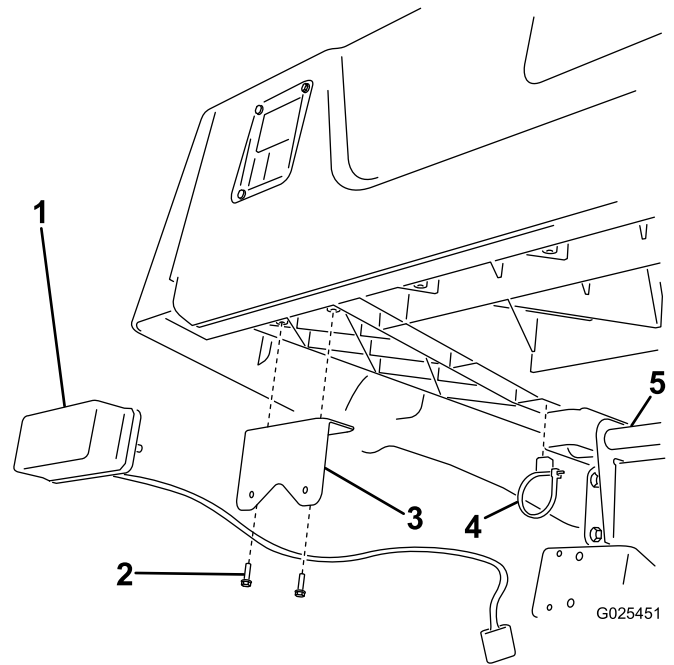

**Figure 18**

- |                     |   |
|---------------------|---|
| 1. Tail light       | 4. Push clip                              |
| 2. Flange-head bolt | 5. Bed pivot tube (secure the cable here) |
| 3. Light bracket    |   |

2. Mount the tail lights to the brackets with the amber colored lights oriented to the outside of the machine (Figure 17 and Figure 18).
3. For 2013 and older models, push a cable tie clip onto the ribs on each side of the box as shown in (Figure 17). For 2014 and newer models, move onto step 4.
4. Route the wires from the lights through the cable tie on the clips and over the bed pivot tube (Figure 17 and Figure 18).
5. Secure the wires with the cable ties on the clips and 2 additional cable ties on the pivot tube.

# 9

## Installing the Rear Wiring Harness

### Parts needed for this procedure:

1	Rear wiring harness
2	Cable-tie clip
1	Cable tie

### Installing the Rear Wiring Harness

1. Lay out the rear harness as shown in Figure 19.

**Note:** The longer length of the harness terminates in a flat, 4-pin connector for the tail lights should be routed to the left, rear tail light.

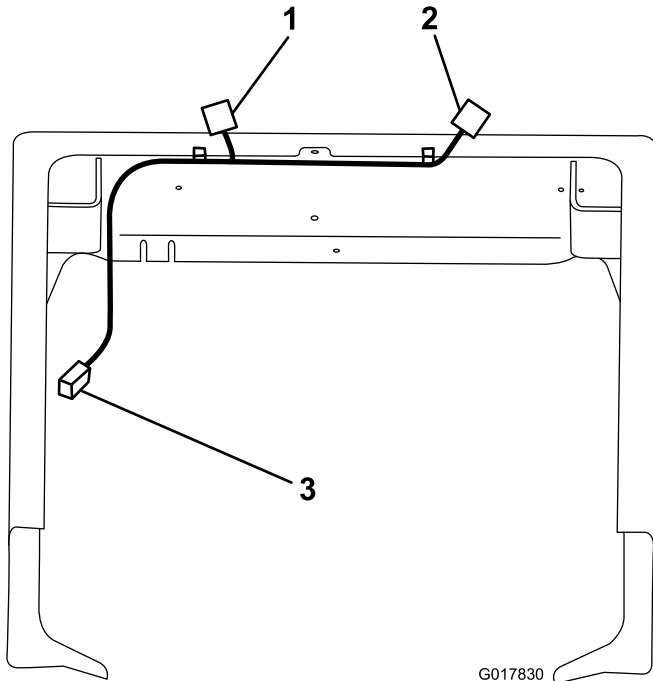

**Figure 19**

Parts removed for clarity

1. Right tail light connector
2. Left tail light connector
3. Main harness connector

2. Secure the rear harness to the machine frame using the 2 plastic cable-tie clips on the harness (Figure 19).
3. Connect the left and right tail light connectors (flat, 4-pin) to the mating connectors coming from the rear tail lights (Figure 19).

**Note:** On model 120–5031, the left hand tail light plugs into the license plate wiring harness which plugs into the rear wiring harness.

4. Route the remainder of the rear wiring harness forward, along the existing main vehicle harness on the right side of the machine (Figure 19).
5. Locate the connector on the main vehicle harness labeled Brake and Signal Light Kit, and connect it to the connector on the end of the new wiring harness (Figure 19).
6. Secure the wiring harness to the existing main vehicle harness along the frame with a cable tie (Figure 19).

# 10

## Installing the Lanyard

### Parts needed for this procedure:

1	Lanyard kit 119-9590 (sold separately)
---	--

### Procedure

Install the Lanyard Kit (119-9590) to prevent the tailgate from blocking the tail lights.

**Notes:**



**Count on it.**