



Midmount Toolbar System

Sand Pro®/Infield Pro® 3040 and 5040 Traction Unit

Model No. 08731—Serial No. 31200001 and Up

Operator's Manual

Important: Before installing the mid-mount toolbar system, you should obtain one of the toolbars available for use with the system. For more information, contact an Authorized Toro Distributor.

Setup

Loose Parts

Use the chart below to verify that all parts have been shipped.

Procedure	Description	Qty.	Use
1	No parts required	–	Do the pre-installation setup.
2	Bolt (5/16 x 2-1/4 inches) Nut (5/16 inch) Scarifier lift-handle assembly Bolt (1/2 x 3-1/4 inches) Thin locknut (1/2 inch) Detent plate Knob	2 2 1 2 2 1 1	Install the scarifier lift-handle assembly.
3	Pivot tube Extension spring Spring rod Pivot tube bracket Bolt (3/8 x 3 inches) Locknut (3/8 inch) Spring bracket Bolt (3/8 x 2-3/4 inches)	1 1 1 2 4 6 1 1	Install the pivot tube and the tension spring.
4	Adjustable rod assembly Bolt (1/2 x 1-1/2 inches) Locknut (1/2 inch)	1 1 2	Install the adjustable rod assembly.
5	Screen panel Pan-head screw (#10 x 1/2 inch) Right-hand saddle assembly Left-hand saddle assembly Bolt (5/16 x 1 inch) Locknut (5/16 inch)	1 2 1 1 4 4	Install the screen panel and saddles.
6	Toolbar (sold separately)	1	Install a toolbar.



Procedure	Description	Qty.	Use
7	Lever assembly	1	Install the toolbar lift pedal.
	Bolt (5/16 x 2 inches)	1	
	Locknut (5/16 inch)	3	
	Pivot tab	1	
	Toolbar link	1	
	Carriage bolt (3/8 x 1-1/4 inches)	1	
	Spacer	1	
	Washer (1 inch)	1	
	Locknut (3/8 inch)	1	
	Pedal lever assembly	1	
	Retaining ring	2	
	Washer (7/8 inch)	1	
	Bolt (5/16 x 1 inch)	1	
	Eccentric bolt	1	
8	No parts required	–	Adjust the pivot spring tension and the adjustable rod assembly.
9	No parts required	–	Adjust the toolbar transport height.
10	Shim (Part no. 110-7379)	1	Level the toolbar.
	Shim (Part no. 110-7380)	1	
	Shim (Part no. 110-7381)	1	
11	No parts required	–	Read/store the documentation.

1

Doing the Pre-Installation Setup

No Parts Required

Procedure

Note: If you will be installing the spring tine toolbar, install the pivot tube brackets supplied with the spring tine toolbar instead of the ones supplied with this attachment. Refer to the *Spring Tine Toolbar Installation Instructions* for more information.

Note: When installing a front manual blade in conjunction with a midmount toolbar system, install the midmount toolbar system first.

2

Installing the Scarifier Lift-handle Assembly

Parts needed for this procedure:

2	Bolt (5/16 x 2-1/4 inches)
2	Nut (5/16 inch)
1	Scarifier lift-handle assembly
2	Bolt (1/2 x 3-1/4 inches)
2	Thin locknut (1/2 inch)
1	Detent plate
1	Knob

Procedure

1. Block up the rear of the machine and remove the rear tires.

Note: Place the blocks under the rear wheel motor mounts.

2. Remove the 4 flange-head screws that secure the right-hand wheel shroud to the frame (Figure 1).

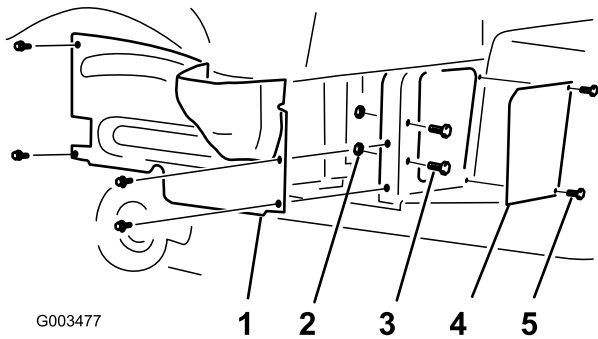

Figure 1

- | | |
|----------------------------|-----------------|
| 1. Right-hand wheel shroud | 4. Screen panel |
| 2. Nut (2) | 5. Screws |
| 3. Bolt and washer (2) | |

3. Remove and retain the shroud.

Note: If a Manual Blade (Model 08714) is installed on the machine, remove the right blade-mounting bracket before installing the lift arm assembly.

4. Remove the 2 screws, 2 bolts, 2 washers and 2 nuts that secure the screen panel to the frame (Figure 1).

Note: Remove and discard the screen panel, but retain the washers and nuts.

5. Install the mounting bracket of the scarifier lift-handle assembly to the right footrest tubes with 2 bolts (1/2 x 3-1/4 inch) and thin locknuts (1/2 inch), as shown in Figure 2.

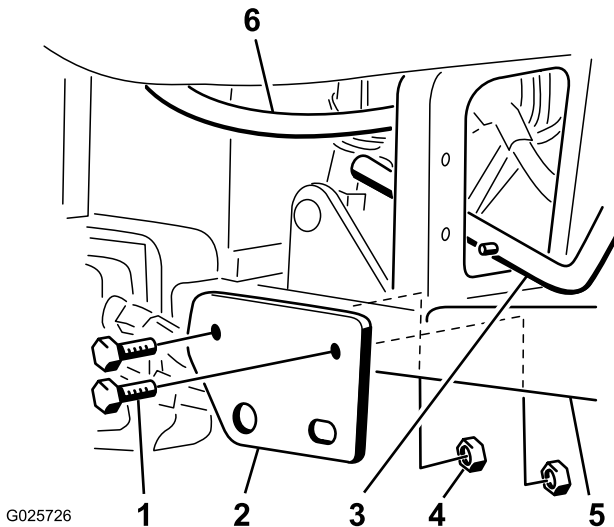

Figure 2

- | | |
|-----------------------------------|-----------------------------|
| 1. Bolt (1/2 x 3-1/4 inch) | 4. Thin locknuts (1/2 inch) |
| 2. Mounting bracket | 5. Footrest tube |
| 3. Scarifier lift-handle assembly | 6. Hydraulic line |

Note: Ensure that the bolt heads are positioned to the outside and that the thin locknuts are used.

Important: There are both thick and thin locknuts in the loose parts. Use the thin locknuts for this

step. If you use the thick ones, they will not lock on and will eventually fall off.

Note: The handle assembly is installed through the bottom of the traction unit by guiding the handle up through the opening made by removing the screen panel.

Note: Do not disassemble the handle assembly to install it into the traction unit.

6. Insert the detent plate onto the scarifier lift handle.

Note: The handle should pass between the detent plate and the handle guide (Figure 3).

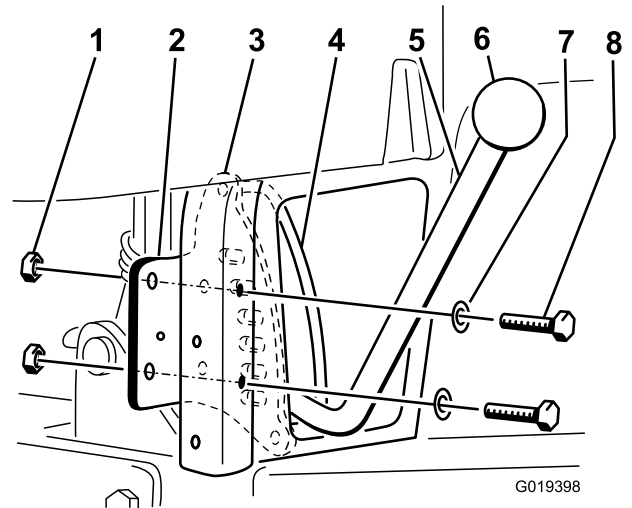

Figure 3

- | | |
|----------------------------|---------------------------------|
| 1. Locknut (5/16 inch) (2) | 5. Scarifier lift handle |
| 2. Right rear frame tube | 6. Knob |
| 3. Detent plate | 7. Washer (2) |
| 4. Handle guide | 8. Bolt (5/16 x 2-1/4 inch) (2) |

7. Install the detent plate to the back of the right rear vertical frame tube with 2 bolts (5/16 x 2-1/4 inch), 2 washers, and 2 locknuts (5/16 inch) (Use the washers and locknuts removed in step 4). Position the parts as shown in Figure 3.)

8. Thread the knob onto the lift handle (Figure 3).

9. Ensure that the lift handle moves the full range of motion through the detent plate and that it locks into place at each detent location.

Note: If the lift handle is too loose or too tight, tighten or loosen the locknuts on the handle lift pivot (Figure 4).

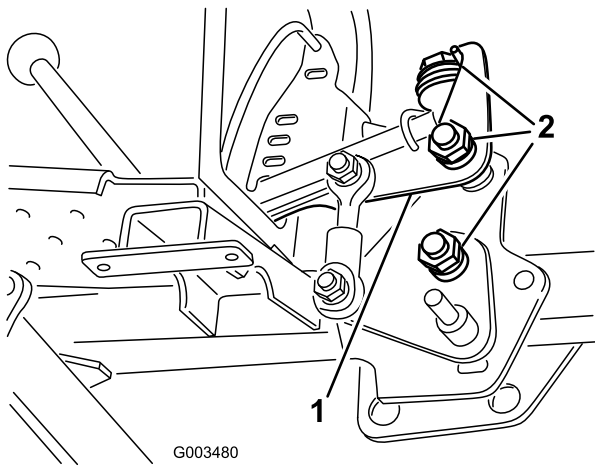

Figure 4

1. Handle lift assembly pivot 2. Locknut

10. Check the clearance between the lift handle assembly and the hydraulic line.

Note: There must be a minimum clearance of 1/8 inch between the hydraulic line and the lift handle assembly. Gently position the hydraulic line as required (Figure 2).

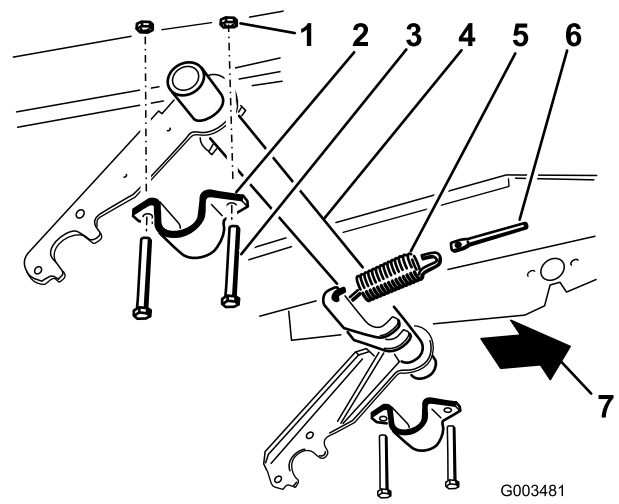

Figure 5

1. Locknut (3/8 inch) 5. Extension spring
 2. Pivot tube bracket 6. Spring rod
 3. Bolt (3/8 x 3 inch) 7. Front of machine
 4. Pivot tube

2. Loosely install the pivot tube bracket onto the right side (Figure 5).
 3. Slide the right-hand side of the pivot tube into the right side pivot tube bracket (Figure 5).
 4. Insert the spring rod into the hole in the spring bracket, and loosely secure it with a locknut (3/8 inch).

Note: Position the spring rod as shown in Figure 6.

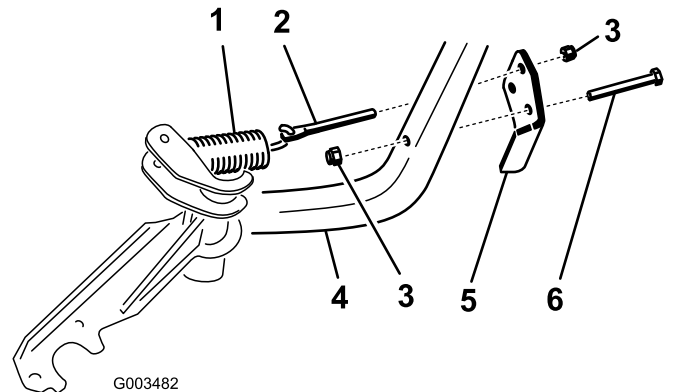

Figure 6

1. Extension spring 4. Frame
 2. Spring rod 5. Spring bracket
 3. Locknut (3/8 inch) 6. Bolt (3/8 x 2-3/4 inch)

5. Raise the left-hand side of the pivot tube to the frame and install it with a pivot tube bracket, 2 bolts (3/8 x 3 inch), and 2 locknuts (3/8 inch) (Figure 5).
 6. Mount the spring bracket to the front frame tube with a bolt (3/8 x 2-3/4 inch) and a locknut (3/8 inch).

Note: Position the spring bracket as shown in Figure 6.

3

Installing the Pivot Tube and the Tension Spring

Parts needed for this procedure:

1	Pivot tube
1	Extension spring
1	Spring rod
2	Pivot tube bracket
4	Bolt (3/8 x 3 inches)
6	Locknut (3/8 inch)
1	Spring bracket
1	Bolt (3/8 x 2-3/4 inches)

Procedure

Note: If you will be installing the spring tine toolbar, install the pivot tube brackets supplied with the spring tine toolbar instead of the ones supplied with this attachment. Refer to the *Spring Tine Toolbar Installation Instructions* for more information.

1. Connect the extension spring to one of the spring levers on the pivot tube and to the spring rod (Figure 5).

- Tighten all fasteners, but do not tighten the locknut that secure the spring rod at this time.

4

Installing the Adjustable Rod Assembly

Parts needed for this procedure:

1	Adjustable rod assembly
1	Bolt (1/2 x 1-1/2 inches)
2	Locknut (1/2 inch)

Procedure

- Position the ball joint of the short end of the adjustable rod assembly to the right of the adjustable rod lever on the pivot tube (Figure 7).

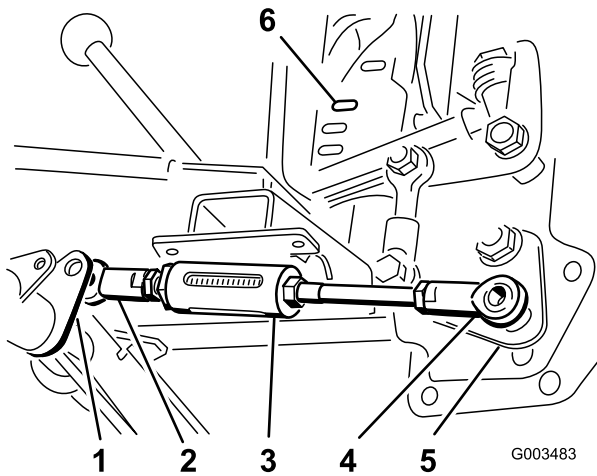

Figure 7

- | | |
|---|---------------------------|
| 1. Adjustable rod lever on the pivot tube | 4. Long-end ball joint |
| 2. Short-end ball joint | 5. Lift handle assembly |
| 3. Adjustable rod | 6. Second detent position |

- Move the lift handle to the second detent position from the top.
- Place the ball joint on the long end of the adjustable rod assembly over the stud on the bottom on the lift handle assembly and loosely secure it with a locknut (1/2 inch) (Figure 7).

Note: You can move the pivot tube up or down in its brackets to gain clearance for mounting the adjustable rod.

- Move the lift handle all the way downward to the bottom detent position.

- Move the ball joint on the short end of the adjustable rod around the adjustable rod lever on the pivot tube until it is on the left side of the rod lever.

Note: You can move the pivot tube up or down in its brackets to gain clearance for mounting the adjustable rod.

- Move the lift handle until the hole in the ball joint aligns with the hole on the right-side of the adjustable rod lever on the pivot tube, and secure the rod to the lever with a bolt (1/2 x 1-1/2 inches) and a locknut (1/2 inch) as shown in Figure 8.

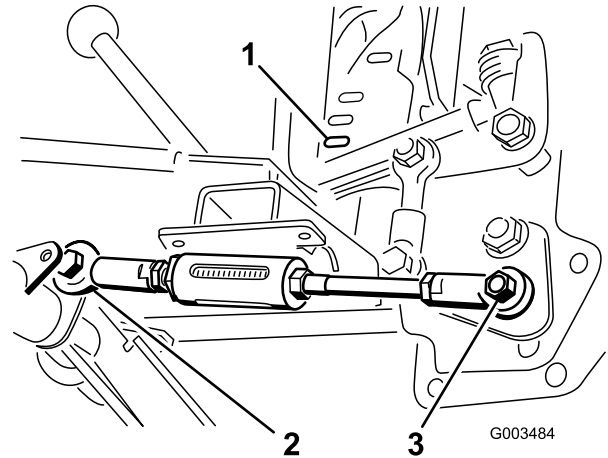

Figure 8

Adjustable rod shown in the fully lowered position

- | | |
|---|--|
| 1. Lowest detent slot | 3. Long end on the stud and secured with a nut |
| 2. Short end secured with a bolt and nut from the left side | |

- Tighten the fasteners.

5

Installing the Screen Panel and Saddles

Parts needed for this procedure:

1	Screen panel
2	Pan-head screw (#10 x 1/2 inch)
1	Right-hand saddle assembly
1	Left-hand saddle assembly
4	Bolt (5/16 x 1 inch)
4	Locknut (5/16 inch)

Procedure

Note: If you removed the manual plow, install it at this time.

1. Install the new screen panel to the **back side** of the frame opening with 2 pan-head screws (#10 x 1/2 inch) (Figure 9).

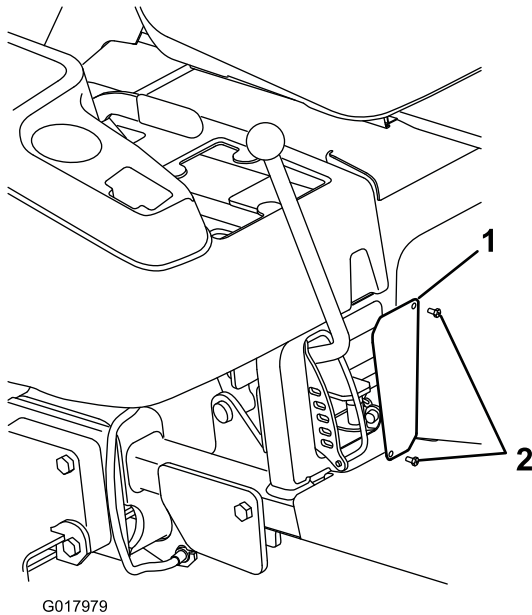

Figure 9

1. New screen panel
2. Pan-head screws (#10 x 1/2 inch)

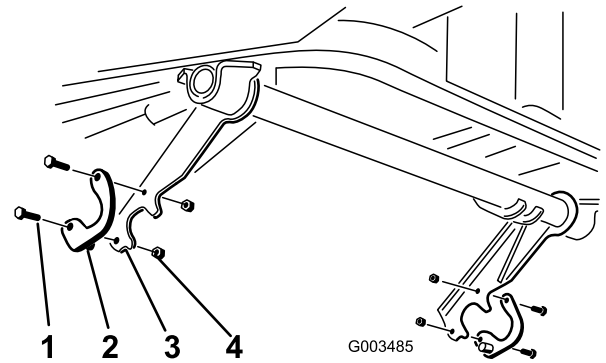

Figure 10

1. Bolt (5/16 x 1 inch)
2. Saddle
3. Lift arm
4. Locknut (5/16 inch)

6

Installing a Toolbar

Parts needed for this procedure:

1	Toolbar (sold separately)
---	---------------------------

Procedure

Important: If you are installing a spring tine toolbar, skip this procedure and install it using the instructions provided with the toolbar. Once installed, go to *Installing the Toolbar Lift Pedal* in these instructions.

Note: If your toolbar comes without the pivot bracket installed, install it to the fourth tooth from the left as shown in Figure 11, and tighten the bolt and nut so that the bracket and tooth are secure before proceeding.

2. Loosely attach the rear of a saddle assembly to each lift arm with a bolt (5/16 x 1 inch) and a locknut (5/16 inch).

Note: The saddle stud should point inward (Figure 10).

Note: Position the saddles as shown in Figure 10.

7

Installing the Toolbar Lift Pedal

Parts needed for this procedure:

1	Lever assembly
1	Bolt (5/16 x 2 inches)
3	Locknut (5/16 inch)
1	Pivot tab
1	Toolbar link
1	Carriage bolt (3/8 x 1-1/4 inches)
1	Spacer
1	Washer (1 inch)
1	Locknut (3/8 inch)
1	Pedal lever assembly
2	Retaining ring
1	Washer (7/8 inch)
1	Bolt (5/16 x 1 inch)
1	Eccentric bolt

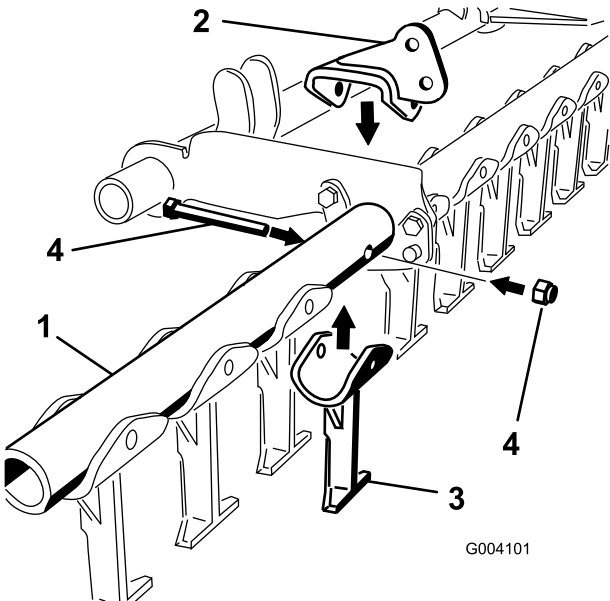

Figure 11

- 1. Toolbar
- 2. Pivot bracket
- 3. Fourth tooth
- 4. Tooth mounting hardware

1. Position each end of the attachment tube onto the saddles.

Note: The cutting edges of the tines should point forward.
2. Move the lift handle to the middle position.
3. Secure the front of each saddle to the tube assembly with a bolt (5/16 x 1 inch) and a locknut (5/16 inch) (Figure 12).

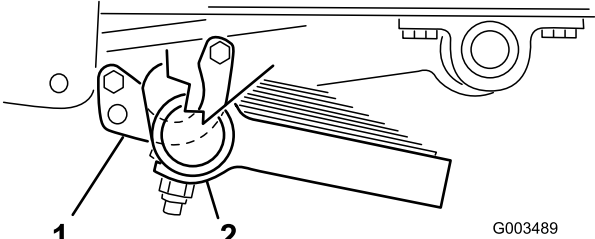

Figure 12

- 1. Saddle
- 2. Attachment tube

Procedure

1. Slide the post on the lever assembly into the left end of the pivot tube, and secure it with a bolt (5/16 x 2 inches) and a locknut (5/16 inch) through the pivot tube (Figure 13).

Note: You may need to thread the bolt through the pivot tube and the lever assembly.

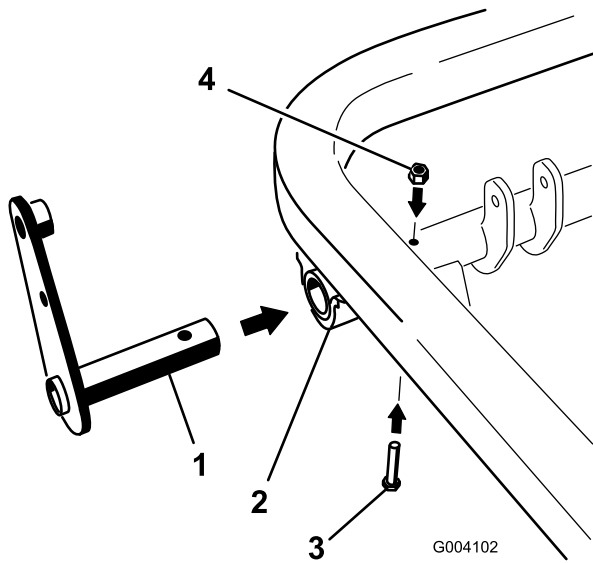

Figure 13

- | | |
|-------------------|---------------------------|
| 1. Lever assembly | 3. Bolt (5/16 x 2 inches) |
| 2. Pivot tube | 4. Locknut (5/16 inch) |

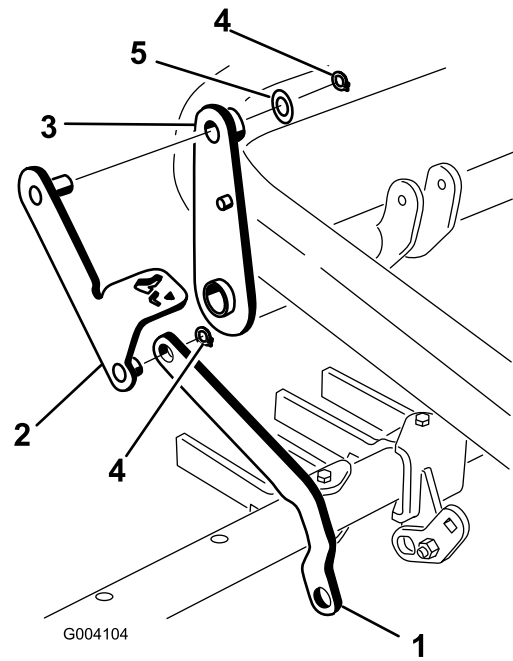

Figure 15

- | | |
|-------------------------|----------------------|
| 1. Toolbar link | 4. Retaining ring |
| 2. Pedal lever assembly | 5. Washer (7/8 inch) |
| 3. Lever assembly | |

- Loosely install the center hole of the pivot tab to the pivot bracket on the toolbar using a bolt (5/16 x 1 inch) and a locknut (5/16 inch) (Figure 14).

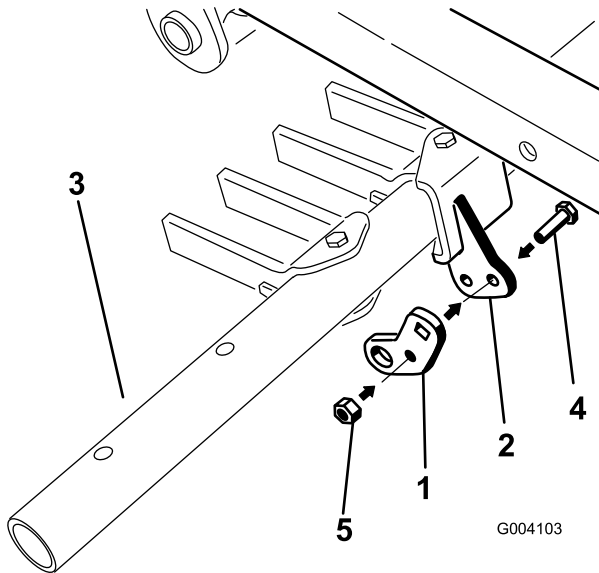

Figure 14

- | | |
|------------------|-------------------------|
| 1. Pivot tab | 4. Bolt (5/16 x 1 inch) |
| 2. Pivot bracket | 5. Locknut (5/16 inch) |
| 3. Toolbar | |

- Slide the end of the toolbar link over the short post on the pedal lever assembly, and secure it with a retaining ring (Figure 15).

- Install the post on the other end of the pedal lever assembly through the top of the lever assembly, and secure it using a washer (7/8 inch) and a retaining ring (Figure 15).
- With the lift pedal assembly knee bent upwards, install the square hole on the pivot tab to the end of the toolbar link using a carriage bolt (3/8 x 1-1/4 inches), a spacer, a washer (1 inch), a washer (13/16 inch), and a locknut (3/8 inch) as shown in Figure 16.

8

Adjusting the Pivot Spring Tension and the Adjustable Rod Assembly

No Parts Required

Procedure

1. Position the lift handle in the top detent position.
2. Measure the distance between the traction unit frame and the pivot tube as shown in Figure 17.

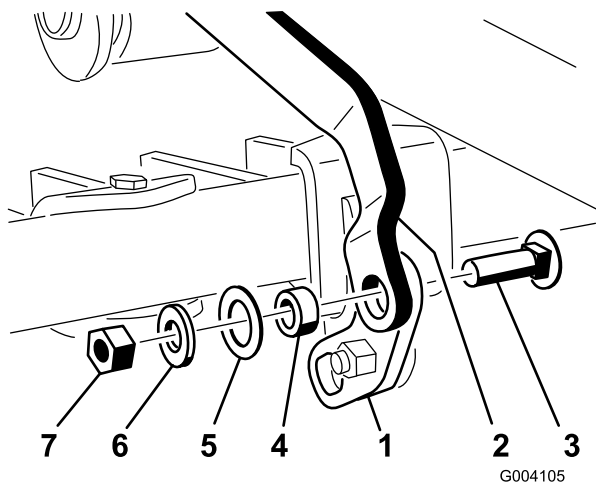

Figure 16

- | | |
|---------------------------------------|------------------------|
| 1. Pivot tab | 5. Washer (1 inch) |
| 2. Toolbar link | 6. Washer (13/16 inch) |
| 3. Carriage bolt (3/8 x 1-1/4 inches) | 7. Locknut (3/8 inch) |
| 4. Spacer | |

6. Install the eccentric bolt through the bottom of the pivot tab and the pivot bracket, and secure it using a locknut (5/16 inch) (Figure 16).

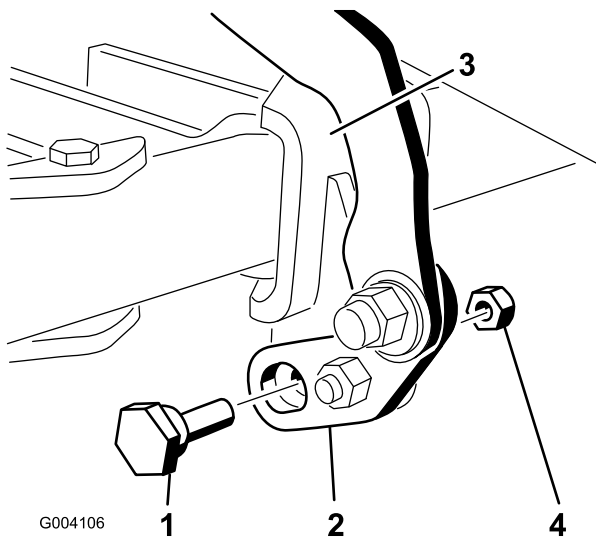

Figure 17

- | | |
|-------------------|------------------------|
| 1. Eccentric bolt | 3. Pivot bracket |
| 2. Pivot tab | 4. Locknut (5/16 inch) |

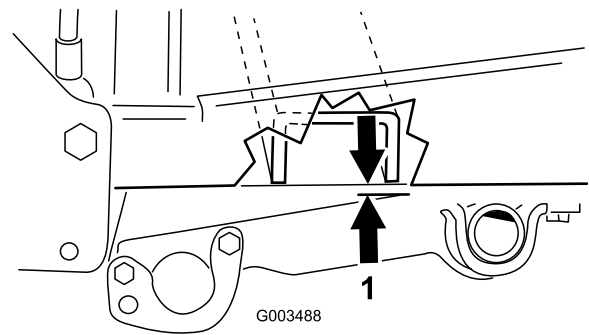

Figure 18

The right side of the machine shown

1. Measure this distance.

If the clearance is not between 0.06 to 0.18 inch, adjust the adjustable rod as follows:

- A. Remove the bolt and nut that secures the rod to the pivot tube (Figure 19).

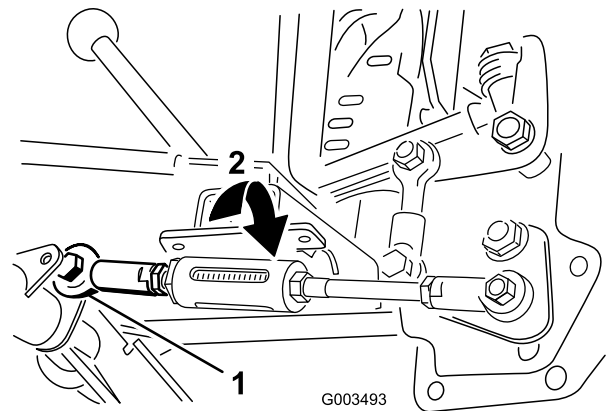

Figure 19

- | | |
|---------------|---------------------|
| 1. Ball joint | 2. Decrease the gap |
|---------------|---------------------|

- B. Rotate the ball joint shown in Figure 18 to change the length of the rod as follows:

- To increase the gap, shorten the rod.
 - To decrease the gap, lengthen the rod.
- C. Install the rod with the bolt and the locknut, and test the clearance again.
 - D. Repeat this procedure until the gap is correct.
3. Tighten the locknuts that secure the spring rod until 1/4 to 1/2 inch (6 mm to 13 mm) of the threads are showing to apply tension to the spring (Figure 19).

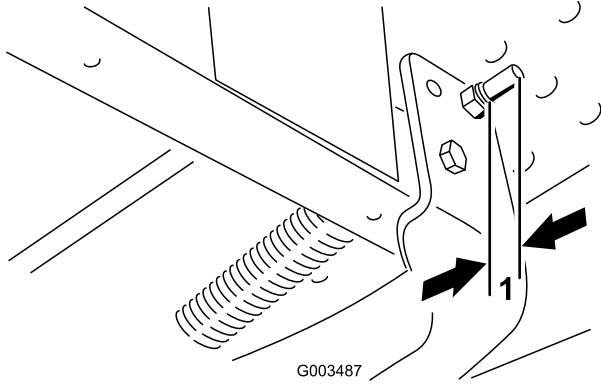

Figure 20

1. 1/4 to 1/2 inches of threads showing (6 mm to 13 mm)

Note: Adjusting the spring rod will vary the lift effort of the system; the longer the bolt ends, the easier it will be to lift the toolbar. Adjust the springs so that the lift force is comfortable. The greater the tension on the assist spring, the less ground pressure there will be on the toolbar.

4. Install the right-hand wheel shroud.
5. Install the rear tires and remove the blocks from under the rear of the machine.

Note: Torque the lugs nuts to 45 to 55 ft-lb (61 to 75 N-m).

9

Adjusting the Toolbar Transport Height

No Parts Required

Procedure

1. Position the lift handle to the transport position (upper most notch).
2. Rotate the eccentric bolt either direction until the toolbar tines are parallel to the notch in the lift arm (Figure 17 and Figure 21).

Important: The eccentric bolt will not rotate 360 degrees. When it stops, do not attempt to force it further or you will damage it. Instead, rotate it back the other direction.

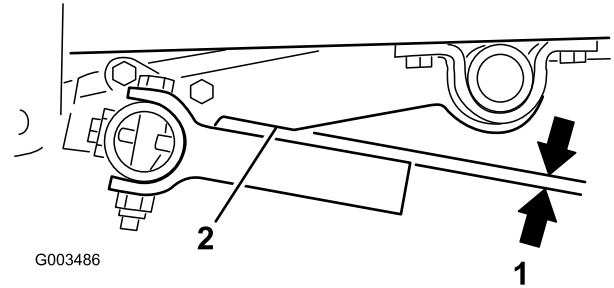

Figure 21

1. Desired position, parallel to the lift arm notch
 2. Notch in the lift arm to the lift arm notch
-
3. Torque the center pivot bolt (item 4 in Figure 13) to 175 to 225 inch-lb (20 to 25 N-m).
 4. Tighten the nut that secures the eccentric bolt until it is secure, but do not over-tighten it.
 5. Test the operation of the attachment.

10

Leveling the Toolbar

Parts needed for this procedure:

1	Shim (Part no. 110-7379)
1	Shim (Part no. 110-7380)
1	Shim (Part no. 110-7381)

Procedure

Once the toolbar has been installed and the fasteners are tightened, use the following procedure to verify that the toolbar teeth are level:

1. Park the machine on a level surface.
2. Check the pressure of all tires and ensure that they are equal. Refer to the Operator's Manual for more information on checking the tire pressure.
3. Lower the toolbar until the teeth just begin to make contact with the ground.
4. If the teeth of the toolbar contact the ground evenly, the toolbar is level.

Note: If the teeth on one side of the toolbar contacts the ground before the other side, level the toolbar. Continue leveling by following the remainder of this procedure.

- Measure the gap from the toolbar teeth to the ground on the side that requires leveling, then use the following table to determine which shim to install based on the gap measurement:

Shim pack (Thickness in inches)	Change in Tooth height (inches) on Outside Edge
110-7379 (.0747 inches)	1/8 inch
110-7381 (.1345 inches)	1/4 inch
110-7379 and 110-7381 (.2094 inches)	3/8 inch
110-7380 (.25 inches)	7/16 inch
110-7379 and 110-7380 (.3247 inches)	9/16 inch

- Loosen the bolts that secure the pivot tube bracket to create an opening between the frame and the pivot tube bracket (Figure 22).

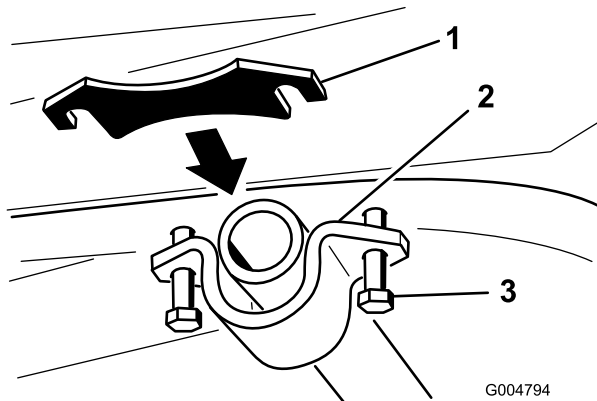

Figure 22

- | | |
|-----------------------|---------|
| 1. Shim | 3. Bolt |
| 2. Pivot tube bracket | |

Note: Installing the shim may require that you remove the lift pedal to access pivot tube bracket. Refer to *Installing the Toolbar Lift Pedal*.

- Install the shim(s) and tighten all fasteners.
- Verify that the toolbar is now level. If not, adjust it as needed.

- Store the documentation in a safe place.

Operation

- To lower the toolbar, move the lift handle to the left, lower it, and then slide it to the right into the desired detent position.
- To raise the toolbar, move the lift handle to the left, raise it, and then slide it to the right into the desired detent position.
- To raise and lock the toolbar into the transport position, move the lift handle to the highest position and press the toolbar lift pedal down.
- To release the toolbar from the transport position, move the lift handle to a lower position.

Note: If you use the scarifier tool bar, rotate the teeth to increase the usable life of the teeth.

Note: To obtain the desired operating position, you may need to first lower the toolbar beyond your desired position, and then raise it back up.

- During operation, you can lower the toolbar into position by backing the machine up slowly while setting the toolbar to the desired depth. Once the toolbar is in the desired position, drive forward. The teeth will make contact with the ground, pulling the toolbar into the engaged position.

Adjusting the Downward Toolbar Pressure

To adjust the amount of downward pressure exerted on the ground by the tool, adjust the spring tension of the adjustable rod. Using a 3/4-inch wrench, rotate the spring sleeve casting on the adjustable rod in the right-hand thread direction to increase the downward pressure or the opposite direction to decrease the downward pressure (Figure 23).

Note: This does not change the adjustable rod setting performed in the *Adjusting the Pivot Spring Tension and the Adjustable Rod Assembly* procedure.

11

Reading/Storing the Documentation

No Parts Required

Procedure

- Read the documentation.

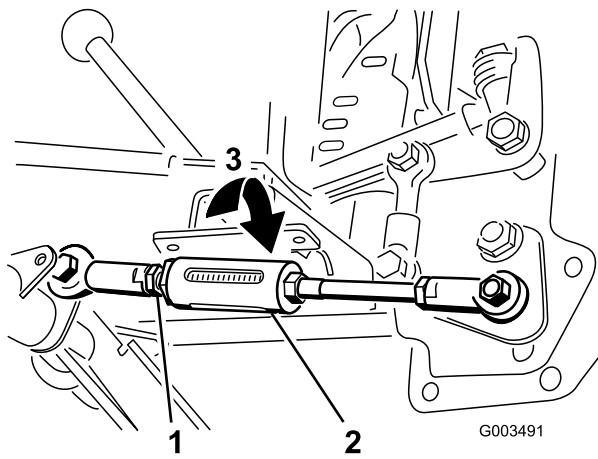

Figure 23

- 1. Adjustable rod assembly
- 2. Spring sleeve casting
- 3. Decrease downward pressure

Use the following table and figure as a guide for adjusting the downward toolbar pressure (Figure 24).

Spring Force Chart	
Dimension (inches)	Force (pounds)
3.00	238
2.88	335
2.75	430
2.62	526
2.50	623

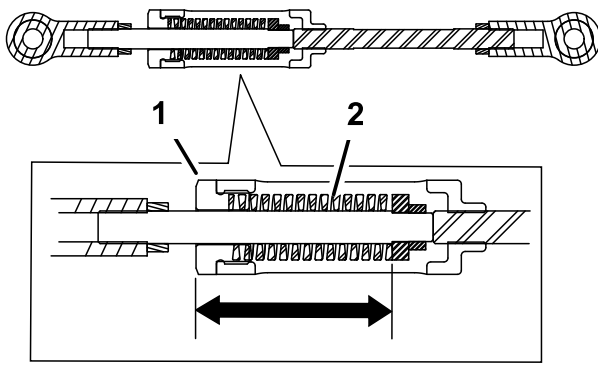

Figure 24

- 1. Spring sleeve casting
- 2. Spring

Troubleshooting

Problem	Possible Cause	Corrective Action
Lifting the attachment requires excessive force	<ol style="list-style-type: none"> 1. The extension springs are too loose. 2. The bell crank or handle assembly is too tight. 3. The adjustable rod is installed on the outside (right) edge of the lift arms on the pivot rod. 	<ol style="list-style-type: none"> 1. Tighten the nuts that secure the spring rods to tension the extension springs, and level the toolbar, if necessary. 2. Loosen the two nuts that secure the bell crank and handle assembly to the scarifier mount assembly (refer to the <i>Parts Catalog</i> for parts illustration). Tighten them until they are snug and then back them off slightly to allow for free rotation. 3. Ensure that the adjustable rod is installed on the left side of the lift arms on the pivot rod; refer to <i>Installing the Adjustable Rod Assembly</i>.
The handle will not lock into the detent slots on the detent plate	<ol style="list-style-type: none"> 1. The nut that secures the handle onto scarifier mount assembly is too tight. 	<ol style="list-style-type: none"> 1. Loosen the nut that secures the handle assembly to the scarifier mount assembly (refer to the <i>Parts Catalog</i> for parts illustration). Tighten the nut until it is snug and then back them off slightly to allow for free rotation.
The toolbar does not rotate high enough 1. The eccentric bolt needs to be adjusted. 1. Refer to <i>Adjusting the Transport Height</i> when in the transport position	<ol style="list-style-type: none"> 1. The eccentric bolt needs to be adjusted. 2. The adjustable rod is too long. 	<ol style="list-style-type: none"> 1. Refer to <i>Adjusting the Transport Height</i>. 2. Shorten the adjustable rod; refer to <i>Adjusting the Pivot Spring Tension and the Adjustable Rod Assembly</i>.
The downward pressure of the attachment is too light	<ol style="list-style-type: none"> 1. The spring tension in the adjustable rod is insufficient. 	<ol style="list-style-type: none"> 1. Refer to <i>Adjusting the Downward Tool Pressure</i>.
There is uneven ground contact when turning the machine	<ol style="list-style-type: none"> 1. The traction unit tilts when turning tight corners or circles. 	<ol style="list-style-type: none"> 1. Install the optional stiffer sidewall tires available from your Authorized Toro Distributor.
The machine stops when it hits an obstacle	<ol style="list-style-type: none"> 1. The adjuster rod is installed incorrectly 	<ol style="list-style-type: none"> 1. Refer to <i>Installing the Adjustable Rod Assembly</i>.
The toolbar teeth are not level	<ol style="list-style-type: none"> 1. The incorrect shim pack is installed. 	<ol style="list-style-type: none"> 1. Refer to <i>Installing the Shim Pack</i>.

Notes:

Notes:



The Toro Total Coverage Guarantee

A Limited Warranty

Conditions and Products Covered

The Toro Company and its affiliate, Toro Warranty Company, pursuant to an agreement between them, jointly warrant your Toro Commercial product ("Product") to be free from defects in materials or workmanship for two years or 1500 operational hours*, whichever occurs first. This warranty is applicable to all products with the exception of Aerators (refer to separate warranty statements for these products). Where a warrantable condition exists, we will repair the Product at no cost to you including diagnostics, labor, parts, and transportation. This warranty begins on the date the Product is delivered to the original retail purchaser.

* Product equipped with an hour meter.

Instructions for Obtaining Warranty Service

You are responsible for notifying the Commercial Products Distributor or Authorized Commercial Products Dealer from whom you purchased the Product as soon as you believe a warrantable condition exists. If you need help locating a Commercial Products Distributor or Authorized Dealer, or if you have questions regarding your warranty rights or responsibilities, you may contact us at:

Toro Commercial Products Service Department
Toro Warranty Company
8111 Lyndale Avenue South
Bloomington, MN 55420-1196
952-888-8801 or 800-952-2740
E-mail: commercial.warranty@toro.com

Owner Responsibilities

As the Product owner, you are responsible for required maintenance and adjustments stated in your *Operator's Manual*. Failure to perform required maintenance and adjustments can be grounds for disallowing a warranty claim.

Items and Conditions Not Covered

Not all product failures or malfunctions that occur during the warranty period are defects in materials or workmanship. This warranty does not cover the following:

- Product failures which result from the use of non-Toro replacement parts, or from installation and use of add-on, or modified non-Toro branded accessories and products. A separate warranty may be provided by the manufacturer of these items.
- Product failures which result from failure to perform recommended maintenance and/or adjustments. Failure to properly maintain your Toro product per the Recommended Maintenance listed in the *Operator's Manual* can result in claims for warranty being denied.
- Product failures which result from operating the Product in an abusive, negligent, or reckless manner.
- Parts subject to consumption through use unless found to be defective. Examples of parts which are consumed, or used up, during normal Product operation include, but are not limited to, brake pads and linings, clutch linings, blades, reels, rollers and bearings (sealed or greasable), bed knives, spark plugs, castor wheels and bearings, tires, filters, belts, and certain sprayer components such as diaphragms, nozzles, and check valves, etc.
- Failures caused by outside influence. Conditions considered to be outside influence include, but are not limited to, weather, storage practices, contamination, use of unapproved fuels, coolants, lubricants, additives, fertilizers, water, or chemicals, etc.
- Failure or performance issues due to the use of fuels (e.g. gasoline, diesel, or biodiesel) that do not conform to their respective industry standards.

Countries Other than the United States or Canada

Customers who have purchased Toro products exported from the United States or Canada should contact their Toro Distributor (Dealer) to obtain guarantee policies for your country, province, or state. If for any reason you are dissatisfied with your Distributor's service or have difficulty obtaining guarantee information, contact the Toro importer.

- Normal noise, vibration, wear and tear, and deterioration.
- Normal "wear and tear" includes, but is not limited to, damage to seats due to wear or abrasion, worn painted surfaces, scratched decals or windows, etc.

Parts

Parts scheduled for replacement as required maintenance are warranted for the period of time up to the scheduled replacement time for that part. Parts replaced under this warranty are covered for the duration of the original product warranty and become the property of Toro. Toro will make the final decision whether to repair any existing part or assembly or replace it. Toro may use remanufactured parts for warranty repairs.

Deep Cycle and Lithium-Ion Battery Warranty:

Deep cycle and Lithium-Ion batteries have a specified total number of kilowatt-hours they can deliver during their lifetime. Operating, recharging, and maintenance techniques can extend or reduce total battery life. As the batteries in this product are consumed, the amount of useful work between charging intervals will slowly decrease until the battery is completely worn out. Replacement of worn out batteries, due to normal consumption, is the responsibility of the product owner. Battery replacement may be required during the normal product warranty period at owner's expense. Note: (Lithium-Ion battery only): A Lithium-Ion battery has a part only prorated warranty beginning year 3 through year 5 based on the time in service and kilowatt hours used. Refer to the *Operator's Manual* for additional information.

Maintenance is at Owner's Expense

Engine tune-up, lubrication, cleaning and polishing, replacement of filters, coolant, and completing recommended maintenance are some of the normal services Toro products require that are at the owner's expense.

General Conditions

Repair by an Authorized Toro Distributor or Dealer is your sole remedy under this warranty.

Neither The Toro Company nor Toro Warranty Company is liable for indirect, incidental or consequential damages in connection with the use of the Toro Products covered by this warranty, including any cost or expense of providing substitute equipment or service during reasonable periods of malfunction or non-use pending completion of repairs under this warranty. Except for the Emissions warranty referenced below, if applicable, there is no other express warranty. All implied warranties of merchantability and fitness for use are limited to the duration of this express warranty.

Some states do not allow exclusions of incidental or consequential damages, or limitations on how long an implied warranty lasts, so the above exclusions and limitations may not apply to you. This warranty gives you specific legal rights, and you may also have other rights which vary from state to state.

Note regarding engine warranty:

The Emissions Control System on your Product may be covered by a separate warranty meeting requirements established by the U.S. Environmental Protection Agency (EPA) and/or the California Air Resources Board (CARB). The hour limitations set forth above do not apply to the Emissions Control System Warranty. Refer to the Engine Emission Control Warranty Statement supplied with your product or contained in the engine manufacturer's documentation for details