

MODEL NO. 03410-30001 & UP (2 WD)
MODEL NO. 03430-30001 & UP (3 WD)

OPERATOR'S
MANUAL

REELMASTER 216[®] - GAS
TRACTION UITS

To assure maximum safety, optimum performance, and to gain knowledge of the product, it is essential that you or any other operator of the mower read and understand the contents of this manual before the engine is ever started. Pay particular attention to the SAFETY INSTRUCTIONS highlighted by this symbol.



The safety alert symbol means CAUTION, WARNING or DANGER - personal safety instruction. Failure to comply with the instruction may result in personal injury.

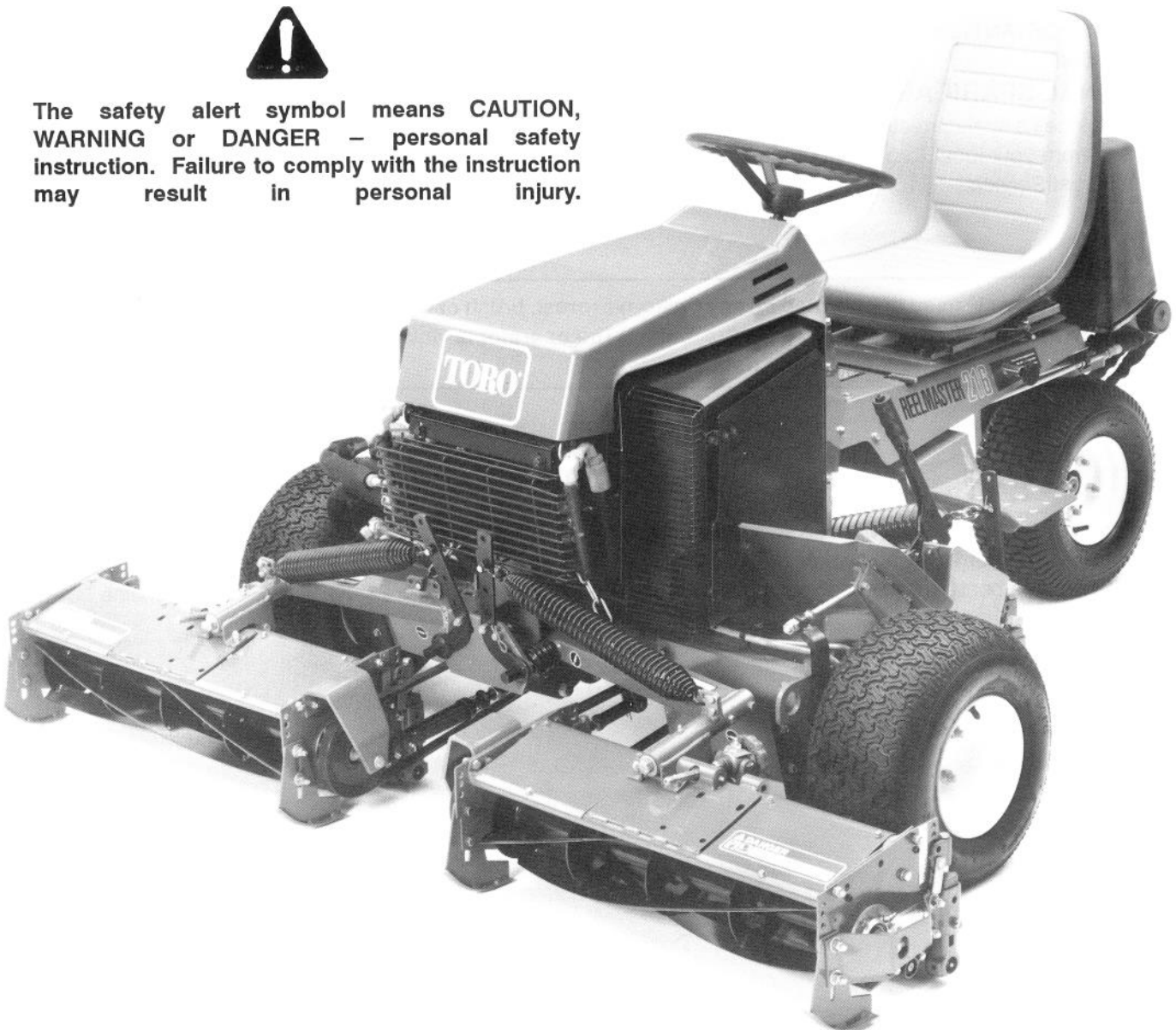

FOREWORD

Your new REELMASTER 216 was developed to provide an efficient, reliable and time-saving method of mowing high quality turf. The latest concepts in engineering and design have been incorporated into this machine along with the highest quality parts and workmanship. Excellent service will be derived if proper operation and maintenance practices are followed.

We know, since you have purchased the industry leader in mowing excellence, that future performance and dependability are of prime importance. TORO also is concerned about future use of the machine and of safety to the user. Therefore, this manual should be read by you and those involved with the REELMASTER 216 to ensure that safety, proper set-up, operation and maintenance procedures are followed at all times. The major sections of the manual are:

1. Safety Instructions
2. Set-up Instructions
3. Before Operating Instructions
4. Operating Instructions
5. Maintenance

Safety, mechanical and some general information in this manual is emphasized. DANGER, WARNING and CAUTION identify safety messages. Whenever the triangular safety alert symbol appears, it is followed by a safety message that must be read and understood. For more complete details concerning safety, read the safety instructions on pages 4 and 5. IMPORTANT identifies special mechanical information and NOTE identifies general information worthy of special attention.

OPTIONAL SPARK ARRESTER

In some places a spark arrester muffler must be used because of local, state or federal regulations. The spark arrester available from your local Toro Distributor is approved by the United States Department of Agriculture and the United States Forest Service.

When the mower is used or operated on any California forest, brush or grass covered land, a properly operating spark arrester must be attached to the muffler. The operator is violating state law, Section 442 Public Resources Code if a spark arrester is not used.

Whenever you have questions or need service, contact your local authorized Toro Distributor. In addition to having a complete line of accessories and professional turf care service technicians, the distributor has a complete line of genuine TORO replacement parts to keep your machine operating properly. Keep your TORO all TORO. Buy genuine TORO parts and accessories.

TABLE OF CONTENTS

	Page		Page
SAFETY INSTRUCTIONS	4-5	Adjust Steering Column	20
Before Operating	4	Towing Traction Unit	21
While Operating	4	Training Period	21
Maintenance	5	Before Mowing	21
SAFETY INSTRUCTIONS & DECALS	6	Operating Characteristics	21
SPECIFICATIONS	7	Transport Operation	21
LOOSE PARTS CHART	8	Inspection and Clean-Up After Mowing	21
SET-UP INSTRUCTIONS	9-15	Cutting Unit Characteristics	22
Install Rear Wheel	9	Cutting Unit Daily Adjustments	22
Install Steering Wheel	9	LUBRICATION	22-23
Installing Seat	9	MAINTENANCE	24-29
Install Front Pivot Rods	10	Changing Crankcase Oil	24
Mount Front Roller	10	Servicing Air Cleaner	24
Set Height-of-Cut and Level Rear Roller	11	Adjusting Carburetor	25
Adjust Bedknife Parallel To Reel	11	Checking and Replacing Spark Plug	25
Verify Height-of-Cut Setting	12	Cleaning Cylinder Head Fins	26
Mount Cutting Units	12	Changing Hydraulic System Fluid and Filter ..	26
Install Cutting Unit Drive Belts	13	Replacing Fuel Filter	26
Install Belt Tensioners To Cutting Units	13	Adjusting Transmission For Neutral	27
Adjust Pulley Cleaners	13	Belt Adjustments	28
Install Counterbalance Springs	14	Adjusting Steering Stops	28
Add Rear Ballast	15	Adjusting Traction Pedal	28
Install Rear Weights	15	Hand Brake Adjustment	28
Activate and Charge Battery	15	Adjusting Clutch	28
BEFORE OPERATING	16-17	Adjust Hood Latch	29
Check Crankcase Oil	16	Battery Care	29
Fill Fuel Tank With Gasoline	16	Battery Storage	29
Check Hydraulic System Fluid	17	Backlapping	29
Check Tire Pressure	17	HYDRAULIC SCHEMATIC	30
Check Reel to Bedknife Contact	17	ELECTRICAL SCHEMATIC	31
CONTROLS	18-19	IDENTIFICATION AND ORDERING	31
OPERATING INSTRUCTIONS	20-22	MAINTENANCE CHART	32-34
Starting/Stopping Engine	20	SLOPE CHART	35
Check Operation of Interlock Switches	20	THE TORO PROMISE	Back Cover



SAFETY INSTRUCTIONS

Improper use or maintenance by the operator or owner of the machine can result in injury. To reduce the potential for any injury, comply with the following safety instructions.

WARNING: Engine exhaust contains carbon monoxide which is an odorless, deadly poison. Carbon monoxide is also known to the State of California to cause birth defects. Do not run engine indoors or in an enclosed area.

BEFORE OPERATING

1. Operate the machine only after reading and understanding the contents of this manual. A free replacement manual is available by sending complete model and serial number to: The Toro Company, 8111 Lyndale Ave. S., Minneapolis, MN 55420.
2. Only trained operators, skilled in slope operation and who have read this manual should operate the machine. Never allow children to operate the machine or adults to operate it without proper instructions.
3. **IMPORTANT:** Always use proper rear ballast as specified in this manual; see Rear Ballast, page 15.
4. Become familiar with the controls and know how to stop the machine and engine quickly.
5. Do not carry passengers on the machine. Keep everyone, especially children and pets, away from the areas of operation.
6. Keep all shields, safety devices and decals in place. If a shield, safety device or decal is damaged, malfunctioning or illegible, repair or replace it before operating the machine.
7. Always wear substantial shoes. Do not operate machine while wearing sandals, tennis shoes or sneakers. Do not wear loose fitting clothing because it could get caught in moving parts and possibly cause personal injury.
8. Wearing safety glasses, safety shoes, long pants and a helmet is advisable and required by some local ordinances and insurance regulations.
9. Make sure the work area is clear of objects which might be picked up and thrown by the reels.
10. Since gasoline is highly flammable, handle it carefully.
 - A. Use an approved gasoline container.
 - B. Do not remove cap from fuel tank when engine is hot or running.
 - C. Do not smoke while handling gasoline.
 - D. Fill fuel tank outdoors and not over one inch (25 mm) from the top of the tank, not the filler neck. Do not overfill.

WHILE OPERATING

11. Do not run the engine in a confined area without adequate ventilation. Exhaust fumes are hazardous and could be deadly.
12. Sit on the seat when starting and operating the machine.
13. Check the interlock switches daily for proper operation, refer to page 20. If a switch should fail, replace the switch before operating the machine. (After every two years, replace all four interlock switches in the wiring system, regardless if they are working properly or not.)
14. When starting the engine:
 - A. Engage parking brake.
 - B. Be sure traction pedal is in neutral and reel drive is in disengage position.
 - C. After engine starts, release parking brake and keep foot off traction pedal. Machine must not move. If movement is evident, the neutral control linkage is incorrectly adjusted: therefore, shut engine off and adjust until machine does not move when traction pedal is released. Refer to Adjusting Transmission for Neutral, page 27.
 - D. Hills over 15 degrees should be mowed up and down, not side to side; see slope gauge, page 35.
 - E. Mowing hills may be dangerous. However, hills over 20 degrees generally should not be mowed unless special safeguards, skills and conditions exist; see slope gauge, page 35.
 - F. Stay alert for holes in terrain and other hidden hazards. Use extreme care when operating close to sand traps, ditches, creeks, steep hillsides or other hazards.
 - G. Reduce speed when making sharp turns. Avoid sudden stops and starts. Use reverse pedal for braking. Cutting units must be lowered when going down slopes for steering control.
 - H. Before backing up, look to the rear and assure no one is behind the machine. Watch out for traffic when near or crossing roads. Always yield the right of way.
15. Keep hands, feet and clothing away from moving parts and the reel discharge area. Grass baskets, if so equipped, must be in place during reel operation for maximum safety.
16. This product may exceed noise levels of 85 dB(A) at the operator position. Ear protectors are recommended for prolonged exposure to reduce the potential of permanent hearing damage.
17. Raise the cutting units when driving from one work area to another.



SAFETY INSTRUCTIONS

18. Do not touch engine, muffler, exhaust pipe or hydraulic tank while engine is running or soon after it has stopped because these areas could be hot enough to cause burns.

19. If a cutting unit strikes a solid object or vibrates abnormally, stop immediately. Turn engine off, wait for all motion to stop and inspect for damage. A damaged reel or bedknife must be repaired or replaced before operation is continued.

20. Before getting off the seat:

- A. Move traction pedal to neutral.
- B. Set the parking brake.
- C. Disengage the cutting units and wait for the reels to stop spinning.
- D. Stop the engine and remove key from the ignition switch.

21. Whenever machine is left unattended, make sure reels are not spinning, key is removed from ignition switch and parking brake is set.

MAINTENANCE

22. Before servicing or making adjustments to the machine, stop the engine, remove key from switch and disconnect wire from spark plug to prevent accidental starting of the engine.

23. Check performance of all four interlock switches daily. Do not defeat interlock system. It is for your protection.

24. To ensure entire machine is in good operating condition, frequently check and keep all nuts, bolts, screws and hydraulic fittings tight.

25. Make sure all hydraulic line connectors are tight, and all hydraulic hoses and lines are in good condition before applying pressure to the system.

26. Keep body and hands away from pin hole leaks or nozzles that eject hydraulic fluid under high pressure. Use paper or cardboard, not hands, to search for leaks. Hydraulic fluid escaping under pressure can have sufficient force to penetrate skin and do serious damage. If fluid is injected into the skin it must be surgically removed within a few hours by a doctor familiar with this form of injury or gangrene may result.

27. Before disconnecting or performing any work on the hydraulic system, all pressure in system must be relieved by stopping engine and lowering cutting units to the ground.

28. If major repairs are ever needed or if assistance is desired, contact an Authorized Toro Distributor.

29. To reduce potential fire hazard, keep the engine area free of excessive grease, grass, leaves and accumulation of dirt.

30. If the engine must be running to perform a maintenance adjustment, keep hands, feet, clothing, and any other parts of the body away from the cutting units and any moving parts. Keep everyone away.

31. Do not overspeed the engine by changing governor settings. To assure safety and accuracy, have an Authorized Toro Distributor check maximum engine speed with a tachometer.

32. Engine must be shut off before checking oil or adding oil to the crankcase.

33. To insure optimum performance and safety, use genuine TORO replacement parts and accessories. Replacement parts and accessories made by other manufacturers could be dangerous, and such use could void the product warranty of The Toro Company



SAFETY AND INSTRUCTION DECALS

The following safety and instruction decals are affixed to the traction unit. If any decal becomes illegible or damaged, install a new decal. Part numbers are listed below and in your Parts Catalog. Order replacements from your Authorized Toro Distributor.

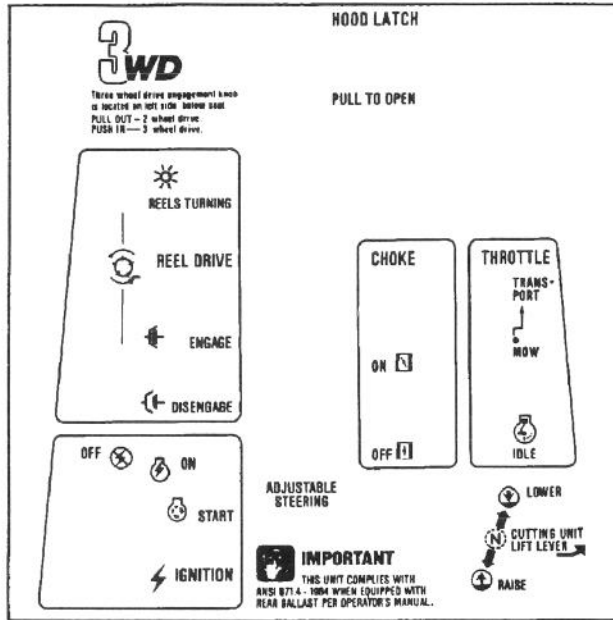

ON INSTRUMENT PANEL
(Part No. 76-0210 - Model 03410)
(Part No. 76-0110 - Model 03430)

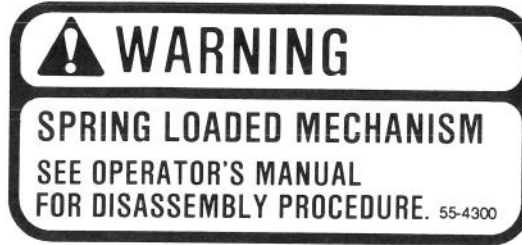

ON LIFT ARMS
(Part No. 55-4300)



ON CUTTING UNIT SHIELD
(Part No. 62-5070)



ON MUFFLER SHROUD AND HYDRAULIC TANK
(Part No. 66-6840)



ON LEFT SIDE OF SEAT PANEL
(Part No. 80-4220)
Model 03430 only



ON SEAT PANEL
(Part No. 83-9550)

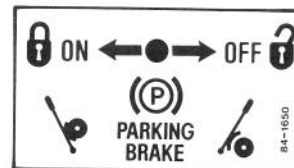

ON LEFT FOOTREST
(Part No. 84-1650)

SPECIFICATIONS

Engine: Kohler, 4 cycle, air cooled, 16 hp @ 3600 rpm, 35.90 cu. in. (588 cc) displacement. Stellite intake and exhaust valve and rotator. Mechanical fuel pump, large capacity dual element air cleaner. 5-1/4 pint oil capacity.

Electrical: 12 volt starter. Electronic solid state ignition. Interlock switches. 15 amp alternator and solid state regulator rectifier.

Fuel Capacity: 6 gallons.

Traction Drive: Hydrostatic drive; variable displacement pump, infinitely variable in both forward and reverse direction. High torque hydraulic wheel motors.

Ground Speed: Infinitely variable speed selection in forward and reverse

Mowing speed: 0-5 mph
Transport speed: 0-6.5 mph
Reverse speed: 0-3 mph

Tires/Wheels: Two front traction drive tires, 18 x 8.50 - 8, tubeless, 4 ply rating. Rear steering tire 18 x 6.50 - 8, 4 ply tire with tube. Recommended tire pressure 12-16 psi.

Frame: Frame consists of formed steel, welded steel and steel tubing components.

Model 03410: Tricycle vehicle with 2-wheel traction drive in front and rear wheel steering.

Model 03430: Tricycle vehicle with 3-wheel traction drive and rear wheel steering.

Brakes: Service braking accomplished through dynamic characteristics of hydrostat. Parking or emergency brake is actuated by ratchet hand lever.

Controls: Foot operated traction pedal with adjustable stop. Hand operated throttle, choke, ignition switch, reel engagement switch, cutting unit lift lever, and parking brake. Model 03430 only: 2 or 3 wheel drive selector valve.

Cutting Unit Lift: Hydraulic lift with automatic reel shut off.

Weight: 1,250 lb with 8 blade cutting unit.

Overall Dimensions:

Wheel tread width;	54"
Wheel base;	55"
Width;	81"
Length;	92"
Height;	43"

Optional Equipment:

Full Roller Kit	Model No. 03440
Sectional Roller Kit	Model No. 03445
Wiehle Roller Kit	Model No. 03450
Skid Kit	Model No. 03446
Anti-Scalp Kit	Model No. 03447
Grass Basket Kit	Model No. 03433
Roller Scraper Kit	Part No. 60-9560
Comb Kit	Part No. 67-9400
Large Pulley Kit*	Part No. 67-9540
Rear Weight - 8 Blade	Part No. 62-5140
Rear Weight - Basket Kit	Part No. 62-7470
Seat Weight Kit	Part No. 80-4210
Gauge Bar Kit	Part No. 13-8199
Backlap Kit	Part No. 84-5510

*Large pulley kit decreases reel speed thus increasing clip rate.

LOOSE PARTS CHART

Note: Use this chart as a checklist to assure all parts necessary for assembly have been received. Without these parts, total set-up cannot be completed. Some parts may have already been assembled at factory.

Wheel Assy.	1	Install Rear Wheel on Model 03410.
Spacers	2	
Flat Washer	1	
Castor Axle	1	
Locknut	1	
Wheel Assy.	1	Install Rear Wheel on Model 03430.
Lug Nuts	4	
Roll Pin	1	Mount Steering Wheel.
Pivot Rod	2	Install to Front Lift Arms.
Capscrews—5/16—18 x 7/8"Lg.	2	
Lockwashers	2	
Thrust Washers	3	Mount Cutting Units to Lift Arms.
Flat Washer	3	
Lockwasher	3	
Capscrew	3	
Capscrew	4	Install Belt Tension Rod to Cutting Unit (Fixed Cutting Units only).
Spacer	4	
Washer	8	
Nut	4	
V—Belt	2	Install to Jackshaft Pulley and Reel Pulley.
Spring	3	Install Counterbalance Springs.
Vinyl Sleeve	1	
Chain	1	
Spring Shackle	3	
Clevis Pin	6	
Cotter Pin	6	
Key	1	
Battery Terminal Boot	1	Secure Battery Cables to Battery.
Capscrew	2	
Nut	2	
Hydraulic Reservoir Plug	1	
Operators Manual	1	Read Before Operating Machine. Fill out and send to the Toro Co.
Parts Catalog	1	
Registration Card	1	
EEC Decals	2	
EEC Certificate	1	

Specifications and design subject to change without notice.

SET-UP INSTRUCTIONS

INSTALL REAR WHEEL (Fig. 1 & 2)

Model 03410 – Two wheel drive

1. Mount wheel assembly to rear castor fork with (2) spacers, flat washer, castor axle and locknut. Spacers to be positioned on inside of fork and washer outside of fork. Torque nut to 45–65 ft–lb.

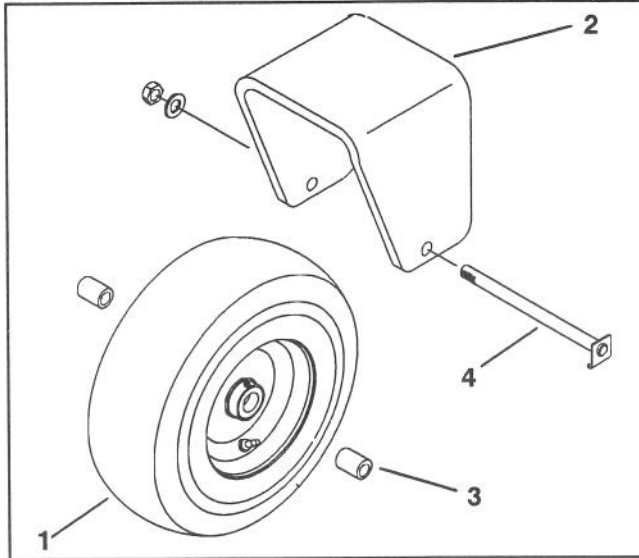

Figure 1

- | | |
|---------------------|----------------|
| 1. Wheel assembly | 3. Spacer (2) |
| 2. Rear castor fork | 4. Castor axle |

Model 03430 – Three wheel drive

1. Mount wheel assembly onto rear wheel hub.

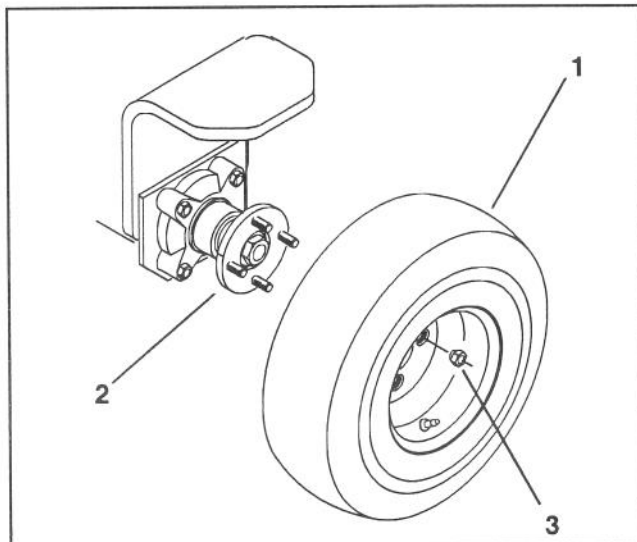

Figure 2

- | |
|-------------------|
| 1. Wheel assembly |
| 2. Rear wheel hub |
| 3. Lug nut |

2. Install lug nuts and torque to 45–65 ft–lb.

INSTALL STEERING WHEEL (Fig. 3)

1. Move rear wheel so it points straight ahead.

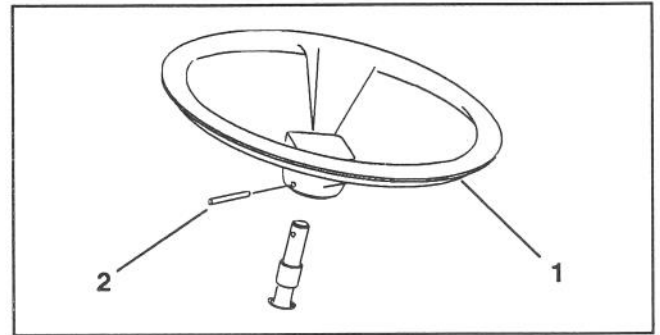

Figure 3

- | |
|-------------------|
| 1. Steering wheel |
| 2. Roll pin |

2. Slide steering wheel onto steering shaft aligning mounting holes.

3. Secure steering wheel in place with roll pin.

INSTALLING SEAT (Fig. 4–5)

The Reelmaster 216 is shipped without the seat assembly. Deluxe Seat Kit, Model 30797 or Standard Seat Kit, Model 30796, must be installed as follows:

1. Remove shipping ties securing lower seat slides to upper seat slides. Note orientation of lower slides for correct reinstallation.

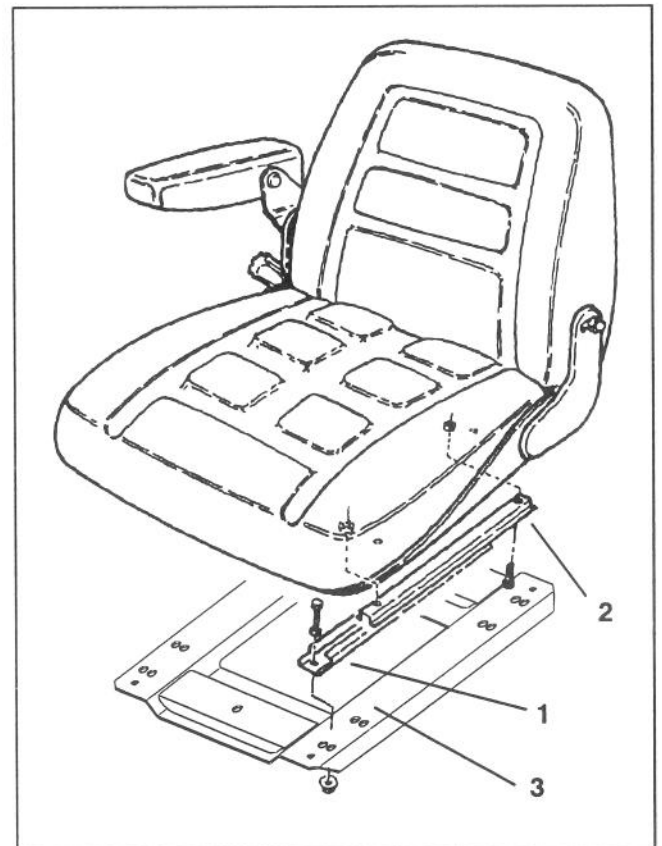

Figure 4

- | |
|---------------------|
| 1. Lower seat slide |
| 2. Upper seat slide |
| 3. Seat plate |

2. Insert lower slides onto upper slides.

SET-UP INSTRUCTIONS

3. On Deluxe Seat, remove machine screws securing upper slides to seat bottom. Move seat slides inward to next set of mounting holes and resecure with machine screws and (4) M8 locknuts. Apply Loctite to fasteners.

4. Loosely secure slides to seat plate with fasteners supplied with seat.

Note: Mount seat in forward holes to attain forward adjustment.

5. Tighten flange nuts and check operation of seat.

Note: For operators that are lightweight, (less than 150 pounds) and short in stature (less than 5'4" tall), an optional weight kit (Toro part no. 80-4210) for seat model 30796 is available from your Authorized Toro Distributor. Mount weight to top of seat plate with (2) capscrews and flange nuts as shown in Figure 5. When using weight, seat slide adjusters should be mounted in the forward set of holes provided in seat plate to insure seat can be positioned forward enough to provide comfortable operation and control of the mower.

Important: Do not use weight with any other seat as it may cause interlock system to malfunction.

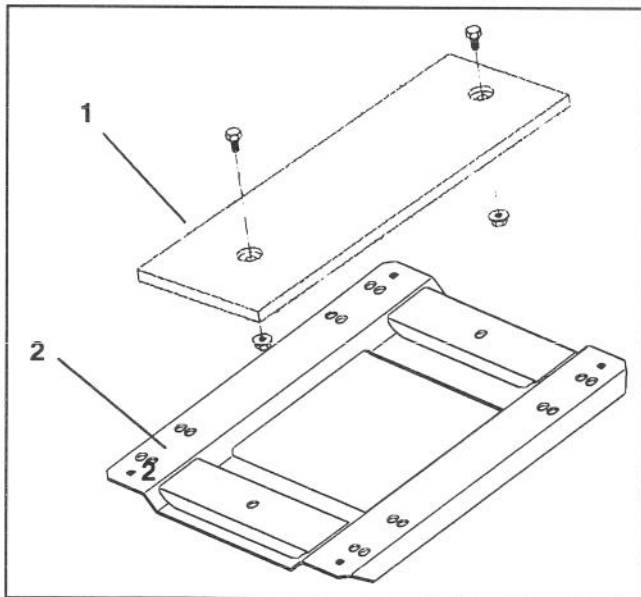

Figure 5

- 1. Seat weight
- 2. Seat plate

INSTALL FRONT PIVOT RODS (Fig. 6)

1. Insert a pivot rod into each lift arm and align mounting holes.

2. Secure a pivot rod to each lift arm with a 5/16 - 18 x 7/8" Lg. capscrews and lockwashers.

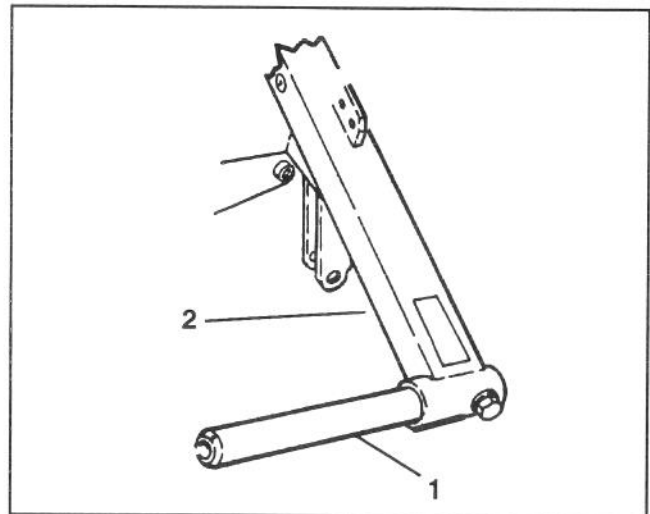

Figure 6

- 1. Pivot rod
- 2. Lift arm

MOUNT FRONT ROLLER (Fig. 7) (Floating Cutting Unit)

1. Remove (2) locknuts securing each angle bracket to cutting unit.

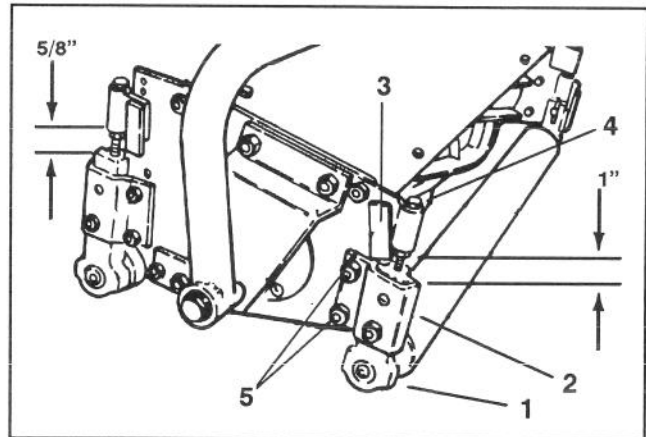

Figure 7

- 1. Roller bracket
- 2. Angle bracket
- 3. Height-of-cut pin
- 4. Support cap screw
- 5. Locknuts

2. Remove height-of-cut pins.

3. Insert smaller dia. shaft end of roller into white bushing in roller bracket, making sure flanged end of nylon bushing faces inside toward roller. **Hex of roller bracket must mate with hex of nut adjustment.**

4. Press roller bracket onto other shaft end of roller. **Hex of roller bracket must mate with hex of nut adjustment.**

5. Hold one roller bracket stationary and use other bracket as a wrench to loosen or tighten bearing clearance to allow roller to rotate freely and to eliminate bearing end play.

SET-UP INSTRUCTIONS

6. Roller brackets must be aligned for installation onto cutting unit. If necessary to align after bearing adjustment, remove roller bracket on side with flanged nyloner, align with opposite roller bracket within \pm one hex flat and replace.

7. Reinstall Height-of-Cut pins.

8. Reinstall (2) locknuts securing each angle bracket to cutting unit.

SET HEIGHT OF CUT AND LEVEL REAR ROLLER (Fig. 7) (Floating Cutting Unit)

1. Position cutting unit on a flat level table or board.
2. Slightly loosen (crack) nut securing each roller bracket to angle bracket.
3. Adjust support capscrew to achieve $1" \pm 1/16$ dimension between Height-of-Cut support and *front* roller bracket (2 places).
4. Adjust support capscrew to achieve $5/8" \pm 1/16$ dimension between Height-of-Cut support and *rear* roller bracket (2 places).
5. Remove hairpin cotters securing *rear* Height-of-Cut pins and reinstall in the $1/2"$ setting as indicated on Height-of-Cut plate.
6. Remove hairpin cotters securing front Height-of-Cut pins and reinstall in the $1/4"$ setting as indicated on Height-of-Cut plate to allow clearance between roller and table.
7. Position a $1/2"$ or thicker bar under the reel blades and against the front face of the bedknife. Make sure bar covers the full length of reel blades.
8. Verify if rear roller is level, by inserting a piece of paper under each end of roller.
9. Level roller by adjusting appropriate support capscrew on rear roller supports until roller is parallel and entire length of roller contacts table.
10. When roller is level, adjust both rollers to desired Height-of-Cut pins. **Tighten nuts securing roller brackets.**

SET HEIGHT-OF-CUT AND LEVEL REAR ROLLER (Fig. 8) (Fixed Cutting Units)

1. Position cutting unit on flat level surface or board.
2. Slightly loosen (crack) nuts securing roller brackets to angle brackets.
3. Adjust support capscrews to achieve $5/8" \pm 1/16$ dimension between Height-of-Cut support and roller bracket (2 places).

4. Remove hairpin cotters securing Height-of-Cut pins and reinstall in hole at desired setting as indicated on Height-of-Cut plate.

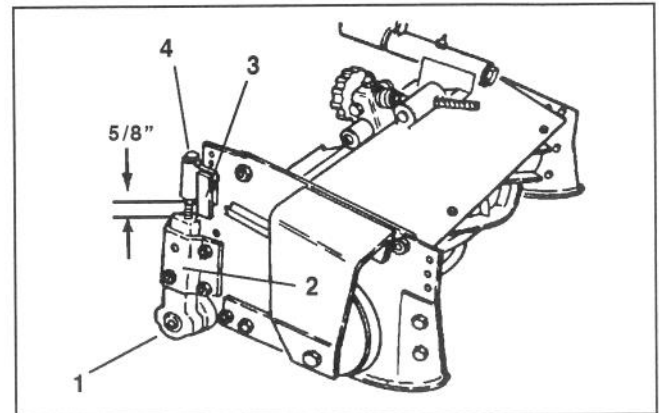

Figure 8

1. Roller bracket
2. Angle bracket
3. Height-of-cut pin
4. Support capscrew

5. Use a gage block with a height equal to the desired height-of-cut and position it against the front edge of the bedknife at one end. Turn the support capscrew to adjust the height of the bedknife equal to the gage block.
6. Repeat the procedure at the other end, then recheck the original end.
7. **Tighten nuts securing roller brackets.**
8. After initial set-up, height-of-cut may be changed by re-positioning Height-of-Cut pins to desired setting.

ADJUST BEDKNIFE PARALLEL TO REEL (Fig. 9-10) (Floating or Fixed Cutting Units)

1. Make sure reel contact is removed by turning bedknife adjustment knob counterclockwise (Fig. 9). Tip cutting unit to gain access to reel and bedknife (Fig. 10).

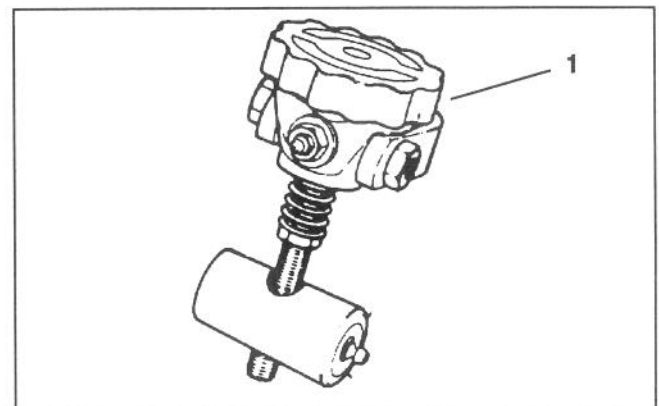

Figure 9

1. Bedknife adjusting screw

SET-UP INSTRUCTIONS

2. On either end of reel, insert a long strip of dry news-paper between reel and bedknife. While slowly rotating reel into bedknife, turn bedknife adjusting knob clockwise, one click at a time until paper is pinched lightly, which results in a slight drag when paper is pulled.

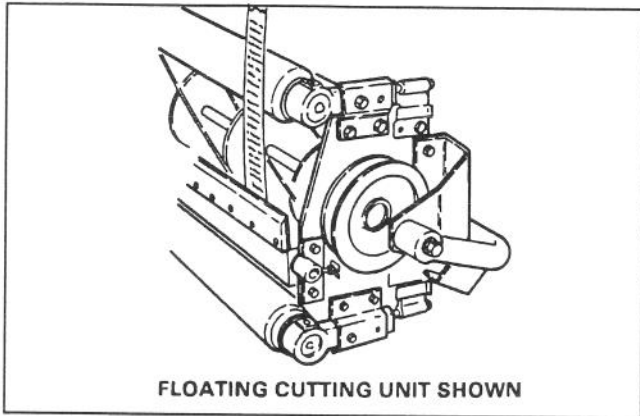

Figure 10

3. Check for light contact at other end of reel using paper. If light contact is not evident, proceed to next step.
4. Loosen (2) carriage bolts on bedbar adjuster (Fig. 11).

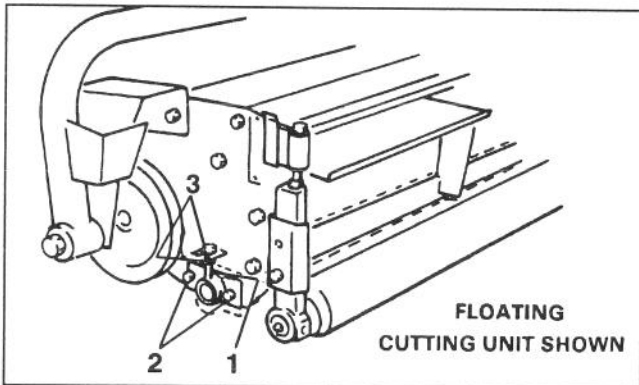

Figure 11

1. Bedbar adjuster
2. Carriage bolts
3. Adjustment nuts

5. Adjust nuts to move bedbar adjuster up or down until paper is pinched along entire bedknife surface, when bedknife adjustment knob is adjusted to no more than two clicks beyond first contact of reel bedknife (Fig. 11).

6. Tighten nuts and carriage bolts and verify adjustment.

VERIFY HEIGHT-OF-CUT SETTING (Fig.12) (Floating Cutting Unit)

1. On gauge bar, set head of screw to desired Height-of-Cut. This measurement is from bar face to underside of screw head. Gauge bar (Toro Part No. 13-8199) may be obtained from your local Toro Distributor.

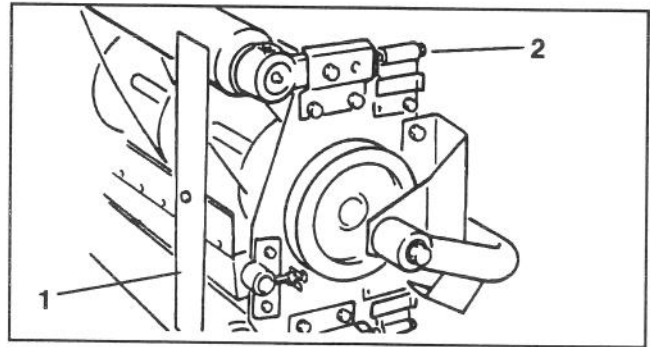

Figure 12

1. Gauge bar
2. Front roller support screw

2. Slightly loosen (crack) nut securing each front roller bracket to angle bracket.

3. Place the bar across the front and rear rollers and adjust the front roller support screws until the underside of screw head engages the bedknife cutting edge. Do this on both ends of reel.

4. Tighten nuts securing roller brackets.

MOUNT CUTTING UNITS (Fig. 13) (Floating Cutting Unit)

1. Slide a thrust washer onto lift arm pivot rod.
2. Slide cutting unit carrier frame onto pivot rod and secure with a flatwasher and capscrew.

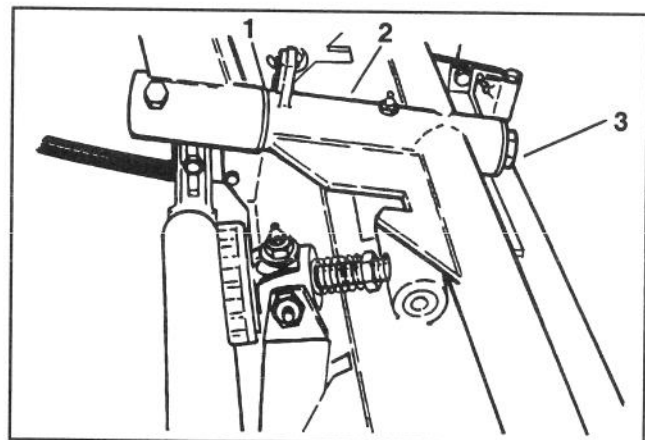

Figure 13

1. Thrust washer
2. Carrier frame
3. Flatwasher and capscrew

MOUNT CUTTING UNITS (Fig. 14) (Fixed Cutting Units)

1. Slide a thrust washer onto lift arm pivot rod.
2. Slide cutting unit support onto pivot rod and secure with a flatwasher and capscrew.

Note: Thrust washer to be positioned between rear of cutting unit support and flatwasher on rear cutting unit.

SET-UP INSTRUCTIONS

Note: When mounting rear cutting unit, thrust washer to be positioned between cutting unit support and flat-washer at rear.

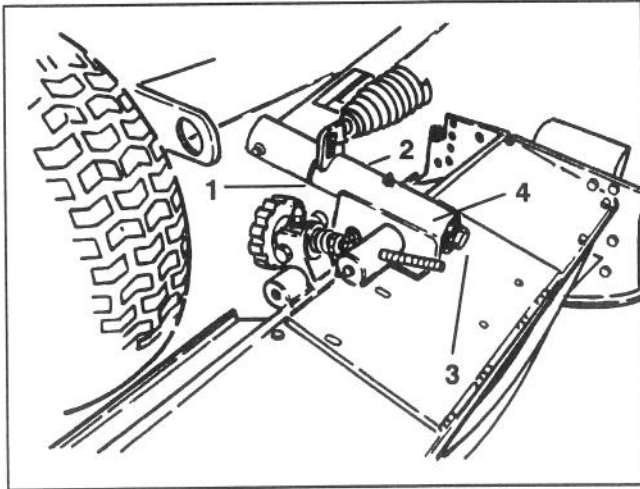

Figure 14

1. Thrust washer
2. Cutting unit support
3. Flatwasher & capscrew

3. Front cutting units should be parallel to front wheels. To adjust, loosen capscrews securing supports to cutting units, adjust cutting units until parallel, then, retighten screws.

INSTALL CUTTING UNIT DRIVE BELTS

(Fig. 15)

(Floating Cutting Units)

1. Route (3) V-belts (two in loose parts) around jack-shaft pulleys and reel pulleys.

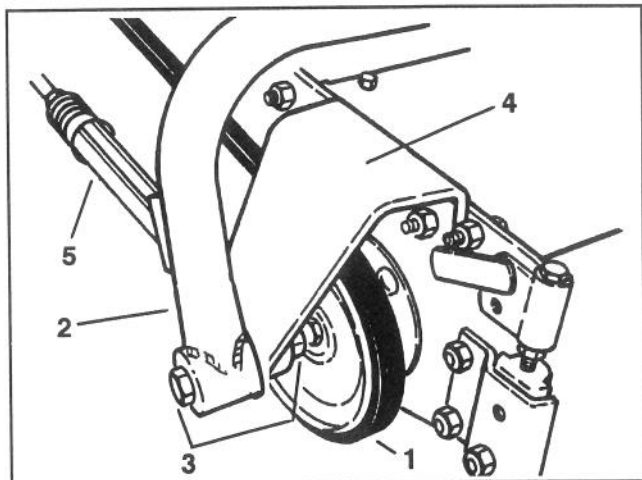

Figure 15

- | | |
|---|----------------------|
| 1. Cutting unit drive belt | 4. Tensioner bracket |
| 2. Carrier frame | 5. Belt tensioner |
| 3. Shoulder bolt, (2) flatwashers & nut | |

INSTALL CUTTING UNIT DRIVE BELTS

(Fig. 16)

(Fixed Cutting Units)

1. Route (3) V-belts (one in loose parts) around jack-shaft pulleys and reel pulleys.

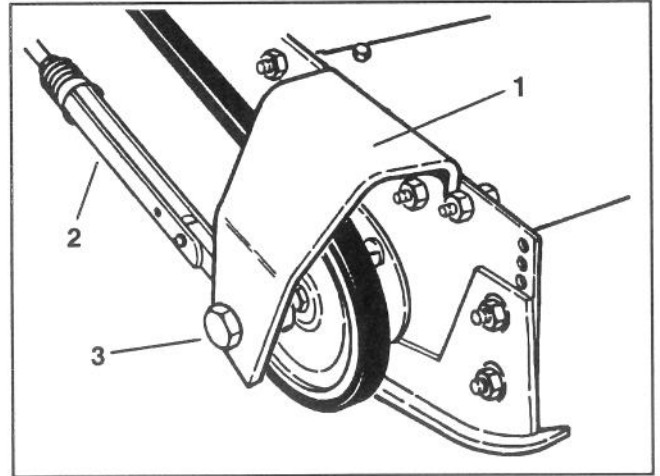

Figure 16

1. Tensioner bracket
2. Belt tensioner
3. Capscrew, (2) flatwashers & nut

INSTALL BELT TENSIONERS TO CUTTING UNITS (Fig. 15)

(Floating Cutting Units)

1. On pulley end of front cutting units and both ends of rear cutting unit, remove nut from bolt securing carrier frame to tensioner bracket.

2. Install a spacer, belt tension rod and washer onto capscrew.

Note: Belt tension rods to be in locked position when installing. Loosen jam nut and rotate rod to adjust rod length for installation.

3. Reinstall nut previously removed.

INSTALL BELT TENSIONERS TO CUTTING UNITS (Fig. 16)

(Fixed Cutting Units)

1. On pulley end of front cutting units and both ends of rear cutting unit, install a washer, spacer, belt tension rod and spacer on capscrew.

Note: Belt tension rods to be in locked position when installing. Loosen jam nut and rotate rod to adjust rod length for installation.

2. Secure with nut.

ADJUST PULLEY CLEANERS (Fig. 17)

1. Adjust cleaner bracket so it is centered in groove of pulley and tighten carriage bolt and locknut.

SET-UP INSTRUCTIONS

- Adjust cleaner bracket so there is approximately .030 – .060 clearance between bracket and pulley, then tighten capscrew and locknut.

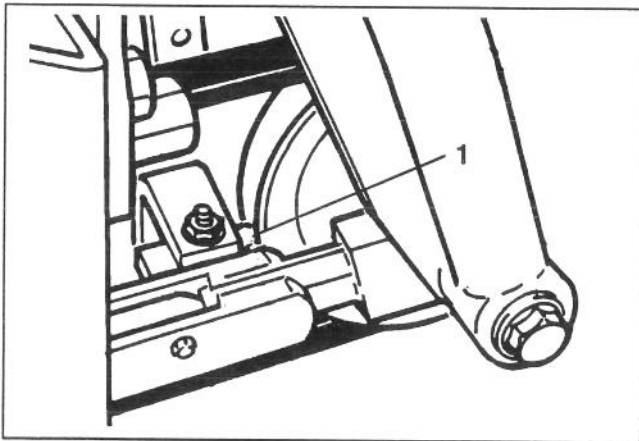

Figure 17
1. Cleaner bracket

INSTALL COUNTERBALANCE SPRINGS

(Figs. 18–20)



WARNING

Use caution when tensioning springs as they are under heavy load.

- Hook one end of spring into second hole (from bottom) on cutting unit lift tab (Fig. 18).

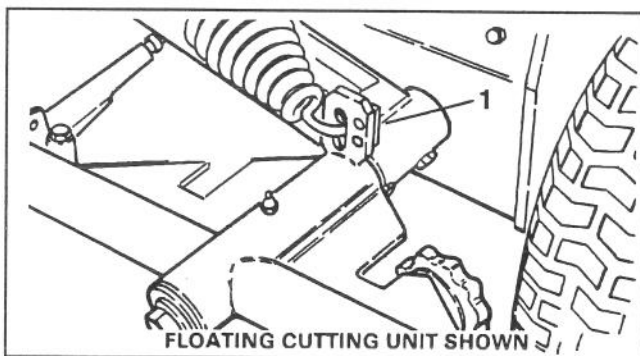

Figure 18
1. Cutting unit lift tab

- On front cutting units secure other end of spring to appropriate hole (see chart) on counterbalance arm with spring shackle, clevis pin and cotter pin.

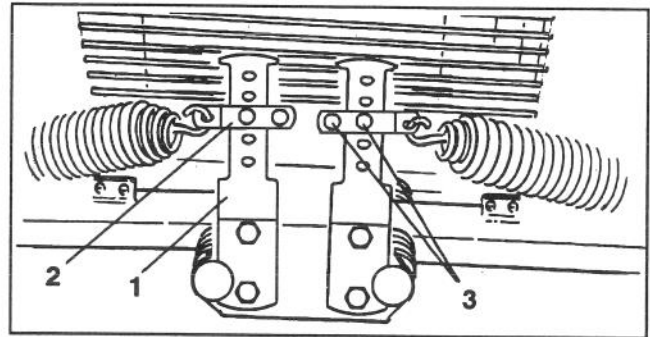

Figure 19
1. Counterbalance arm
2. Spring shackle
3. Clevis pin & cotter pin

Note: On rear counterbalance spring install vinyl cover over spring before installing.

- On rear cutting unit secure other end of spring to appropriate hole (see chart) in counterbalance arm with (2) chain links, (5, 8 & 11 Blade Floating Cutting units) or (3) chain links (5 Blade Fixed Cutting units), spring shackle, clevis, clevis pin and hairpin cotter.

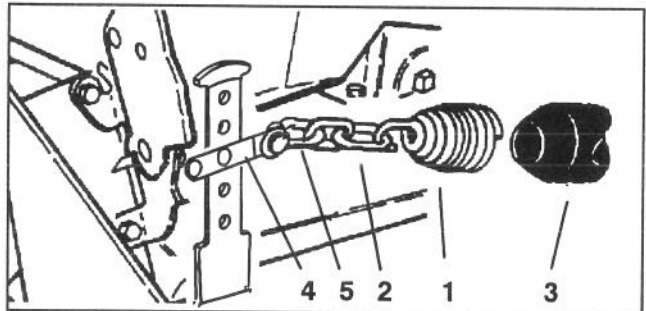

Figure 20
1. Rear counter balance spring
2. Chain links
3. Vinyl cover
4. Spring shackle
5. Shackle

- Second hole from Bottom — for 5 blade reel application
- Middle hole — for 8 & 11 blade reels without baskets
- Top hole — for 8 & 11 blade reels using baskets

IMPORTANT: These are recommended settings. Readjust spring positions to attain optimum performance. By raising spring locations on counterbalance arms, cutting unit weight on ground is reduced and traction is increased.

- To tension the counterbalance springs proceed as follows:

- Remove cotter pin and clevis pin securing spring shackle to counterbalance arm. Do not remove other clevis pin.
- Move shackle up or down on counterbalance arm, until aligned with desired hole of arm. Reinstall clevis pin and cotter pin.

SET-UP INSTRUCTIONS

ADD REAR BALLAST

This unit complies with ANSI B 71.4–1984 Standard when equipped with rear ballast. Use chart below to determine weight or combinations of weights needed.

Cutting Unit Configuration	Weight Required
Fixed (no carrier frame)	Calcium Chloride in rear tire.
Floating (with carrier frame and no baskets)	Calcium Chloride in rear tire and rear weight, Part No. 62–5140.
Floating (with carrier frame and baskets)	Calcium Chloride in rear tire and rear weights, Part No. 62–5140 and 62–7470.

IMPORTANT: If a puncture occurs in a tire with calcium chloride, remove unit from turf area as quickly as possible. To prevent possible damage to turf, immediately soak affected area with water.

Either Type 1 (77%) or Type 2 (94%) commercial calcium chloride flake may be used.

Plain water freezes solid at 32° F (0° C). The 3–1/2 pound (1.6 kg) calcium chloride to one gallon (3.8 L) of water solution is slush free to –12° F (–24° C), and will freeze solid at –52° F (–46° C). The 5 pound (2.3 kg) per gallon (liter) solution is slush free to –50° F (–45° C) and will freeze solid at –62° F (–52° C).

Tires should be filled to approximately 75% capacity (valve level with valve at the top).

TO INSTALL REAR WEIGHT, PART NO. 62–5140

1. Remove (4) capscrews, flatwashers, and spacers securing gas tank mounting plate to rear frame.
2. Discard spacers.
3. Slide weight under gas tank mounting plate aligning mounting holes.
4. Secure weight to frame with fasteners previously removed.

TO INSTALL REAR WEIGHT, PART NO. 62–7470

1. Secure the (2) weights to the bottom of weight, Part No. 62–5140 with fasteners supplied with kit.

ACTIVATE AND CHARGE BATTERY (Fig. 21)

1. If Battery is not filled with electrolyte or activated, bulk electrolyte with 1.260 specific gravity must be purchased from a local battery supply outlet and added to battery.



CAUTION

Wear safety goggles and rubber gloves when working with electrolyte. Charge the battery in a well ventilated place so gasses produced while charging can dissipate. Since the gases are explosive, keep open flames and electrical spark away from the battery; do not smoke. Nausea may result if the gases are inhaled. Unplug charger from electrical outlet before connecting to or disconnecting charger leads from battery posts.

2. Remove filler cap from battery and slowly fill each cell until electrolyte is just above the plates.
3. Replace filler cap and connect a 3 to 4 amp battery charger to the battery posts. Charge the battery at a rate of 3 to 4 amperes for 4 to 8 hours.
4. When battery is charged, disconnect charger from electrical outlet and battery posts.
5. Remove filler cap. Slowly add electrolyte to each cell until level is up to fill ring. Install filler cap.

IMPORTANT: Do not overfill battery. Electrolyte will overflow onto other parts of the machine and severe corrosion and deterioration will result.

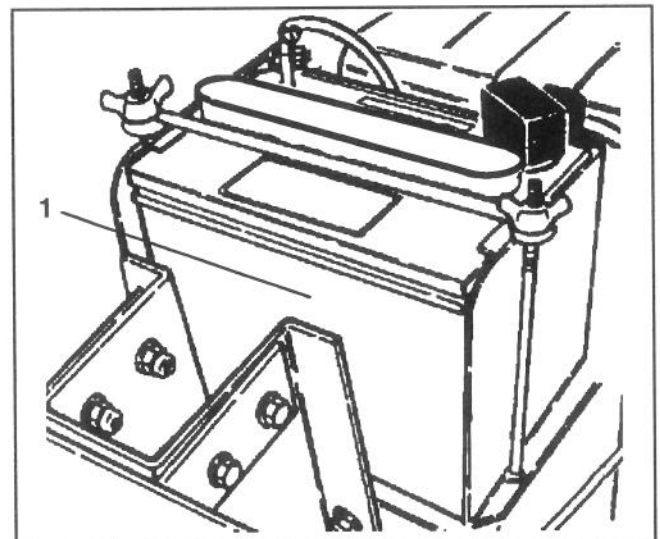

Figure 21

1. Battery

6. Install the positive cable (rubber boot over end) to the positive (+) terminal and the negative cable (black) to the negative (–) terminal of the battery and secure with capscrews and nuts. Slide the rubber boot over the positive terminal to prevent possible short-out from occurring.

BEFORE OPERATING



CAUTION

Before servicing or making adjustments to the machine, stop engine and remove key from the switch.

CHECK CRANKCASE OIL (Fig. 22)

The Kohler engine is shipped with 5–1/4 pints of oil in the crankcase; however, level of oil must be checked before and after the engine is first started.

1. Position machine on a level surface.
2. Remove dipstick and wipe it with a clean rag. Push dipstick down into dipstick tube and make sure it is seated fully. Pull dipstick / filler cap out and check level of oil.

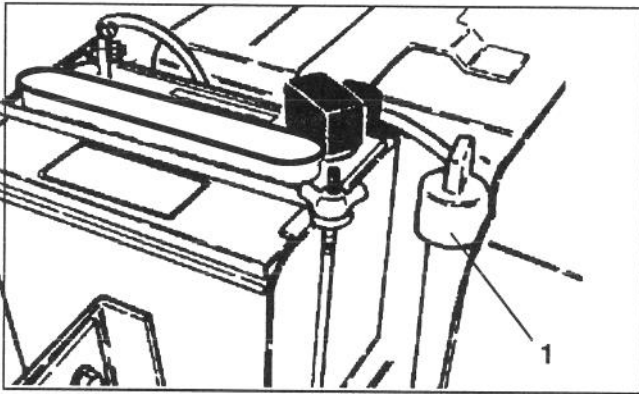

Figure 22

1. Dipstick / Filler cap

3. If oil level is low, add enough oil to raise level to FULL mark on dipstick. Use oil having the API "service classification" SE or SF. Oil viscosity — weight — is selected according to anticipated ambient temperature. Temperature/ viscosity recommendations are:

A. Above 32° F (0° C) — Use SAE 30. The use of multi-weight oil above 32° F (0° C) is not recommended due to increased oil consumption and excessive combustion chamber deposits.

B. Below 32° F (0° C) — Use SAE 5W–20 or 5W–30, and if they are not available, 10W–30 or 10W–40 are acceptable substitutes.

FILL FUEL TANK WITH GASOLINE (Fig. 23)

THE TORO COMPANY STRONGLY RECOMMENDS THE USE OF FRESH, CLEAN, UNLEADED REGULAR GRADE GASOLINE IN TORO GASOLINE POWERED PRODUCTS. UNLEADED GASOLINE BURNS CLEANER, EXTENDS ENGINE LIFE, AND PROMOTES GOOD STARTING BY REDUCING THE BUILD-UP OF COMBUSTION CHAMBER DEPOSITS. LEADED GASOLINE CAN BE USED IF UNLEADED IS NOT AVAILABLE.

Note: Do not mix oil with gasoline. Never use methanol, gasoline containing methanol, gasohol, gasoline additives, premium gasoline, or white gas because engine/fuel system damage could result.



DANGER

Because gasoline is flammable, caution must be used when storing or handling it. Do not fill fuel tank while engine is running, hot or when machine is in an enclosed area. Vapors may build up and be ignited by a spark or flame source many feet away. **DO NO SMOKE** while filling the fuel tank to prevent the possibility of an explosion. Always fill fuel tank outside and wipe up any spilled gasoline before starting engine. Use a funnel or spout to prevent spilling gasoline, and fill tank no higher than to bottom of filter screen. **DO NOT OVER FILL.** Store gasoline in a clean safety approved container and keep the cap on the container. Keep gasoline in a cool, well-ventilated place; never in an enclosed area such as a hot storage shed. To assure volatility, do not buy more than a 30 day supply of gasoline. Gasoline is a fuel for internal combustion engines; therefore do not use it for any other purpose. Since many children like the smell of gas, keep it out of their reach because the fumes are explosive and dangerous to inhale.

Fuel tank capacity is approximately 6 gallons.

1. Clean area around fuel tank cap and remove cap.

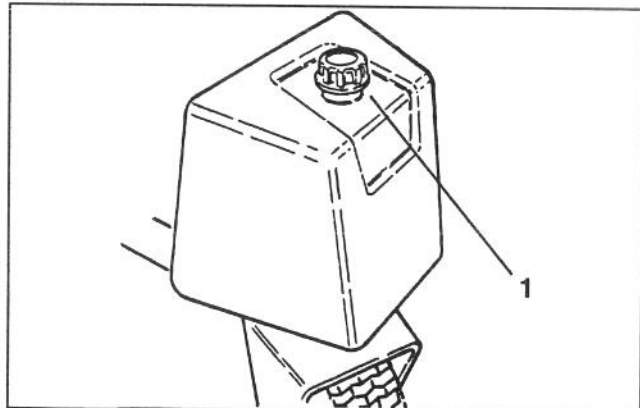

Figure 23

1. Fuel tank cap

2. Fill tank to about one inch below top of tank, (bottom of filler neck). **DO NOT OVERFILL.** Then install cap.
3. Wipe up gasoline that may have spilled to prevent a fire hazard.

BEFORE OPERATING

CHECK HYDRAULIC SYSTEM FLUID

(Fig. 24)

The hydraulic system is designed to operate with Mobil DTE 26 or equivalent anti-wear hydraulic fluid. The machine's reservoir is filled at the factory with approximately 3-1/2 gallons of fluid. However, check level of hydraulic fluid before engine is first started and daily thereafter.

Hydraulic Oil (Recommended brands): (ISO 68)

Mobil	DTE26
Shell	Tellus 68
Amoco	Rykon Oil #68
Conoco	Super Hydraulic Oil 68
Exxon	NutoH68
Kendall	KenoIR&OAW68
Pennzoil	Penreco 68
Phillips	Magnus A 68
Standard	Energol HLP 68
Sun	Sunvis 831 WR
Union	Unaz AW 68

Note: All are interchangeable.

IMPORTANT: Use only hydraulic oils specified. Other fluids could cause system damage.

Note: A red dye additive for the hydraulic system oil is available in 2/3 oz. bottles. One bottle is sufficient for 4-6 gal. of hydraulic oil. Order Part No. 44-2500 from your Authorized Toro Distributor.

1. Position machine on a level surface.
2. Remove dipstick cap from filler neck and wipe it with a clean rag. Insert dipstick cap into filler neck; then remove it and check level of fluid. Fluid level should be between marks on dipstick, add Mobil DTE 26 or equivalent fluid to raise level to full mark. Do not overfill.

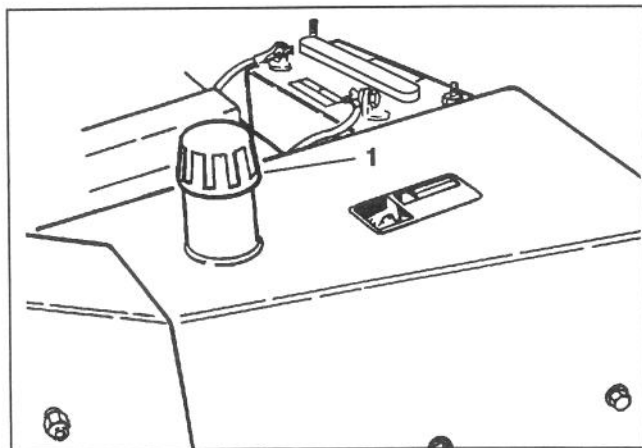

Figure 24

1. Dipstick filler cap

3. Install dipstick filler cap onto filler neck.

CHECK TIRE PRESSURE (Fig. 25)

The tires are over-inflated for shipping. Therefore, release some of the air to reduce the pressure. Correct air pressure in front and rear tires is 12 to 16 psi.

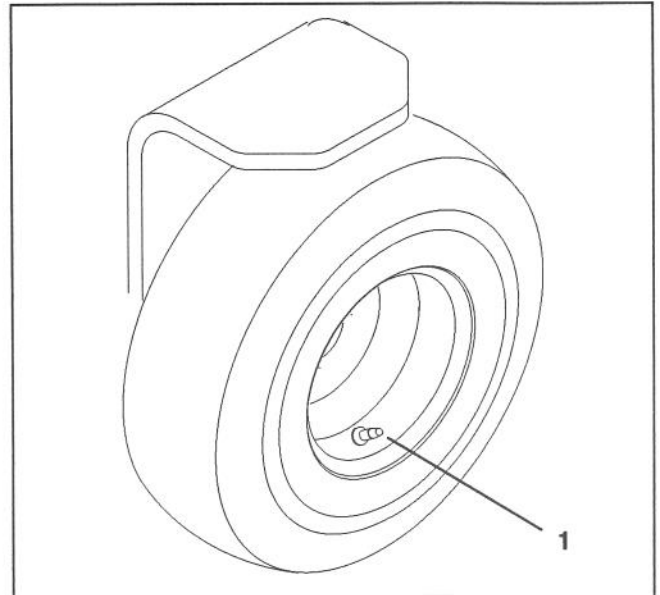

Figure 25

1. Air valve

CHECK REEL TO BEDKNIFE CONTACT

(Fig. 26)

Each day before operating, check reel to bedknife contact, regardless if quality of cut had previously been acceptable. There must be light contact across the full length of the reel and bedknife. Refer to Adjusting Bedknife Parallel To Reel, page 11.

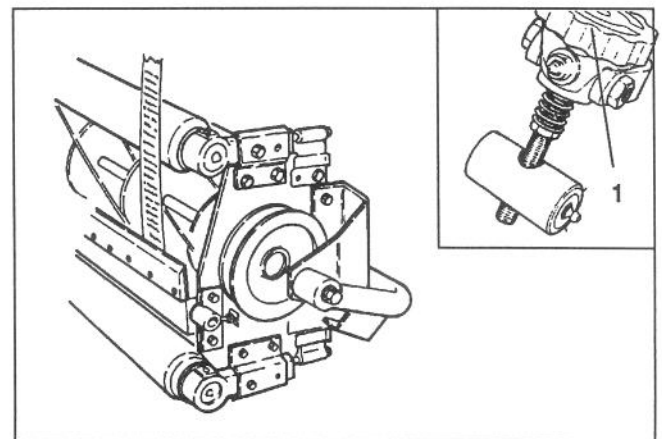

Figure 26

1. Bedknife adjusting screw

KNOW YOUR CONTROLS

Traction and Stopping Pedal (Fig. 27 & 28) — Traction pedal has three functions: one, to make the machine move forward, two, to move it backward and three, to stop machine. Using the heel and toe of the right foot, depress top of pedal to move forward and bottom of pedal to move backward or to assist in stopping when moving forward. Also, allow pedal to move or move it to neutral position to stop machine. **For operator comfort, do not rest heel of foot on reverse when operating forward.**

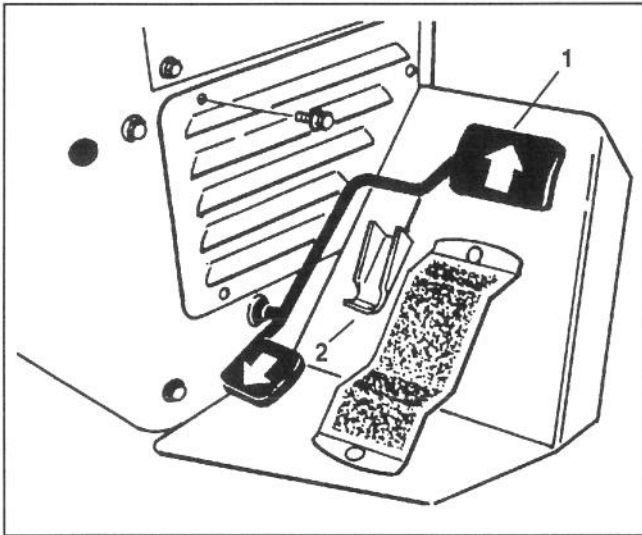

Figure 27

1. Traction pedal
2. Traction pedal stop (forward)

Traction Pedal Stop (Fig. 27) — Used in conjunction with traction pedal to maintain a constant mowing speed. Adjust so pedal contacts stop at desired forward speed. The reverse pedal stop (under pedal) is set at the factory to provide 3 M.P.H. maximum speed in the reverse direction.

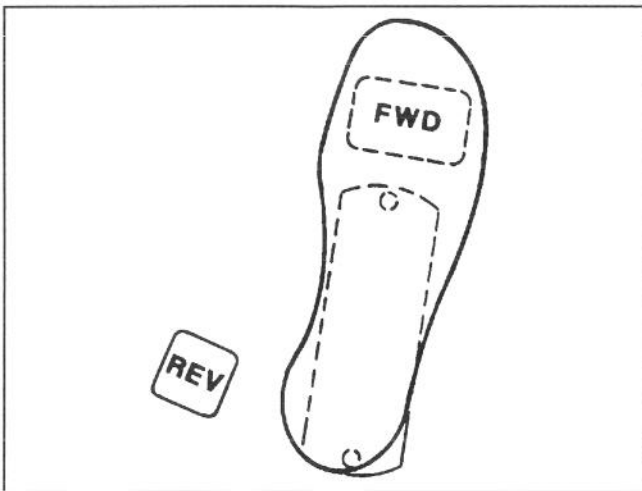

Figure 28

Ignition Switch (Fig. 29) — The ignition switch, used to start and stop the engine, has three positions: OFF, RUN and START. Rotate key clockwise — START position — to engage starter motor. Release key when engine starts. The key will move automatically to the ON position. To shut engine off, rotate key counterclockwise to OFF position.

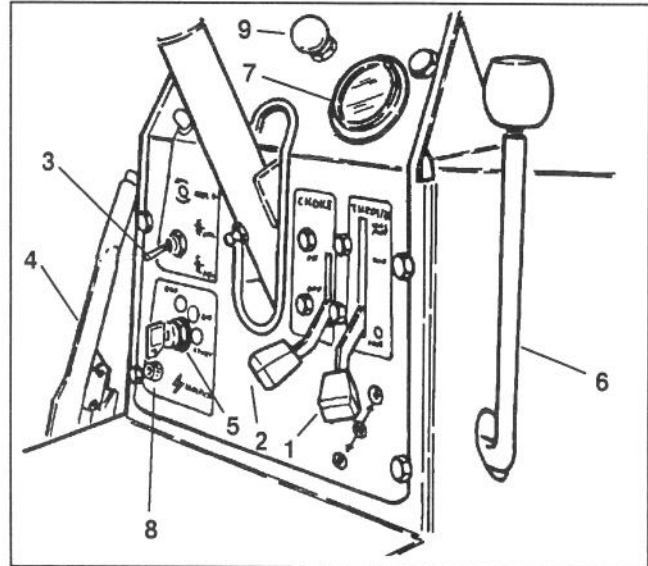

Figure 29

- | | | |
|------------------------------|----------------------------|----------------|
| 1. Throttle control | 4. Parking brake | 7. Hour meter |
| 2. Choke control | 5. Ignition switch | 8. Fuse holder |
| 3. Cutting unit drive switch | 6. Cutting unit lift lever | 9. Hood latch |

Choke (Fig. 29) — To start a cold engine, close carburetor choke by moving choke control upward to ON position. After engine starts, regulate choke to keep engine running smoothly. As soon as possible, open the choke by pulling it downward to the OFF position. A warm engine requires little or no choking.

Throttle (Fig. 29) — Throttle is used to operate engine at various speeds. Moving throttle upward increases engine speed, downward decreases engine speed. The throttle controls the speed of the reel blades and, in conjunction with traction pedal, controls ground speed of the machine. Position control in MOW for normal cutting. To attain TRANSPORT, move control to MOW, push control to right, then up to transport.

Cutting Unit Lift Lever (Fig. 29) The lift lever has three positions: LOWER, RAISE, and NEUTRAL. To lower cutting units to the ground, move lift lever forward. When lowering cutting units, make sure hydraulic cylinder is completely retracted before releasing lift lever. To raise cutting units, pull lift lever rearward to the RAISE position. Cutting units will not operate unless cylinder is retracted or when lifted. To decrease play in lever, tighten retaining locknut.

KNOW YOUR CONTROLS

Cutting Unit Drive Switch (Fig. 29) — The switch has two positions: ENGAGE and DISENGAGE. Toggle switch engages electromagnetic clutch to drive cutting units. Amber light on dash indicate when reels are rotating.

Hour Meter (Fig. 29) — Indicates the total hours of machine operation. The Hour Meter starts to function whenever the key switch is rotated to "ON" position.

Fuse Holder (Fig. 29) — A 30 Amp fuse protects the starter circuit. To replace fuse, rotate knob counter-clockwise and remove fuse from case. Install fuse, insert knob and rotate clockwise to secure in panel.

Parking Brake (Fig. 29) — Whenever the engine is shut off, the parking brake must be engaged to prevent accidental movement of the machine. To engage the parking brake, pull back on lever. After releasing parking brake, move mower slightly in reverse to release brakes before moving forward.

Drive Engagement Control (model 03430 only) (Fig. 30) — On lower left side of operator. Pull knob out for 2 wheel drive; push knob in for 3 wheel drive. Mower must come to a complete stop before shifting from 2 to 3 wheel drive.

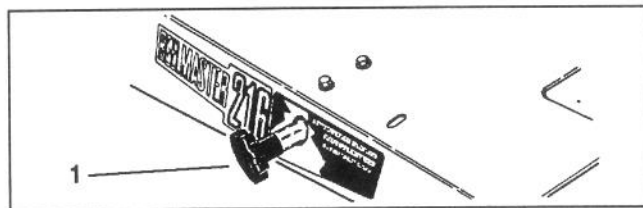

Figure 30

1. Drive engagement control
Pull out - Two wheel drive
Push in - Three wheel drive

Seat Adjustments (Fig. 31)

Fore and Aft Adjustment — Move lever on side of seat outward, slide seat to desired position and release lever to lock seat into position.

Deluxe Seat Adjustments (Fig. 31)

Weight Adjustment — Push lever up or down to adjust to operator's weight. Lever up — light operator, lever in middle position — medium weight operator or lever down for heavy operator.

Inclining Backrest — Turn handle to adjust angle of backrest.

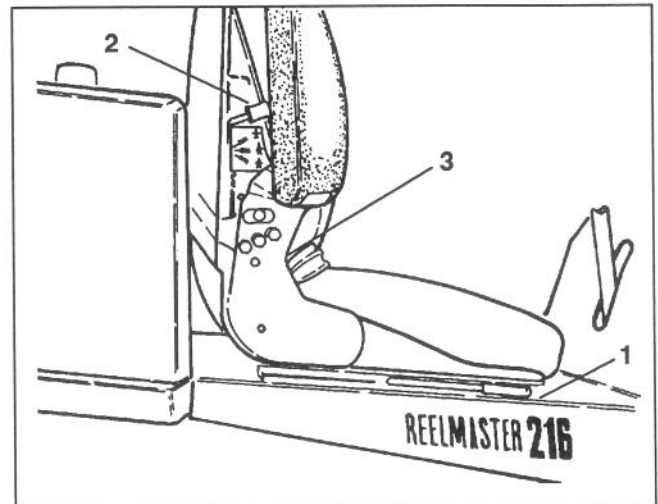

Figure 31

1. Fore and aft lever
2. Weight adjustment lever
3. Inclining backrest

Fuel Shut-off Valve (located behind seat) — Close fuel shut-off valve when storing machine.

OPERATING INSTRUCTIONS

STARTING/STOPPING ENGINE

1. Be sure parking brake is set and Reel Drive switch is in DISENGAGE position.

Note: After hand brake is released, run vehicle in opposite direction of resistance to fully release brake.

2. Remove foot from traction pedal and make sure pedal is in neutral position.

3. Move choke lever to ON position — when starting a cold engine — and throttle lever to half throttle position.

4. Insert key into ignition switch and rotate it clockwise to start the engine. Release key when engine starts. Regulate the choke to keep engine running smoothly.

IMPORTANT: To prevent overheating of the starter motor, do not engage starter longer than 10 seconds. After 10 seconds of continuous cranking, wait 60 seconds before engaging starter motor again.

5. When engine is started for the first time, or after overhaul of the engine, operate the machine in forward and reverse for one to two minutes. Also operate the lift lever and reel drive switch to be sure of proper operation of all parts.

Turn steering wheel to the left and right to check steering response. Then shut engine off and check for oil leaks, loose parts and any other noticeable malfunctions.



CAUTION

Shut engine off and wait for all moving parts to stop before checking for oil leaks, loose parts and other malfunctions.

6. To stop engine, move throttle control downward to IDLE position, move reel drive switch to DISENGAGE and rotate ignition key to OFF. Remove key from switch to prevent accidental starting.

7. Close fuel shut off valve before storing machine.

CHECK OPERATION OF INTERLOCK SWITCHES



CAUTION

Do not disconnect the safety switches because they are for the operator's protection. Check operation of the switches daily to be sure the interlock system is operating correctly. If a switch is not operating properly, replace it before operating the machine. Replace the switches every two years to be sure of maximum safety.

1. With operator off the seat, traction pedal in neutral and cutting unit clutch switch in disengage position, the engine should start. If either the traction pedal is depressed or the cutting unit clutch switch is engaged, the engine should stop. Correct problem if not operating properly.

2. With operator in the seat, engine running, and cutting unit clutch switch engaged, the clutch should be engaged, the dash indicator light glowing and the jackshaft turning when the lift cylinder is fully retracted. As the lift cylinder is extended, the light should go out, the clutch disengage and the jackshaft stop turning. Correct problem if not operating properly.

3. With operator on seat, engine running, clutch switch engaged, cutting units lowered and lift cylinder fully retracted, reels should turn and dash indicator light should glow. If reels do not turn and light does not glow, an adjustment to the cutting unit interlock switch may be necessary.

A. Stop engine and set parking brake.

B. Make sure cutting units are completely lowered and lift cylinder is fully retracted.

C. Locate cutting unit interlock switch on left side of machine on bottom of hydraulic cylinder.

D. Rotate screw out until switch is activated. Check continuity when switch is activated.

E. Check operation and repeat adjustment, if necessary.

ADJUST STEERING COLUMN (Fig. 32)

1. Raise hood.

2. Remove capscrew securing steering column to frame bracket.

3. Adjust steering column to desired operating position and reinstall capscrew.

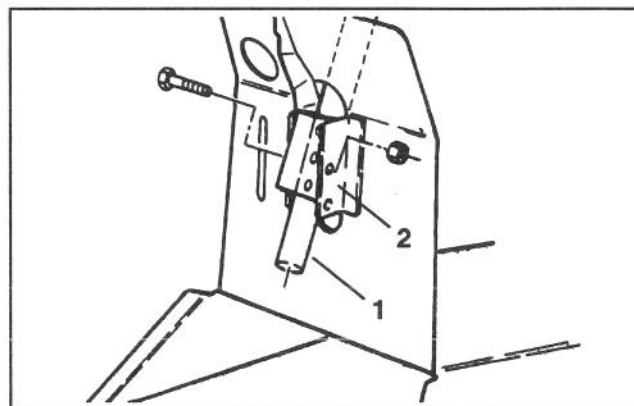

Figure 32

1. Steering column
2. Frame bracket

OPERATING INSTRUCTIONS

TOWING TRACTION UNIT (Fig. 33)

In case of emergency, the Reelmaster 216 can be towed for a short distance. However, Toro does not recommend this as a standard procedure.

IMPORTANT: Do not tow the machine faster than 2–3 mph because drive system may be damaged. If machine must be moved a considerable distance, transport it on a truck or trailer.

1. Reach under front of machine and rotate by-pass valve on pump counterclockwise until it is fully open.

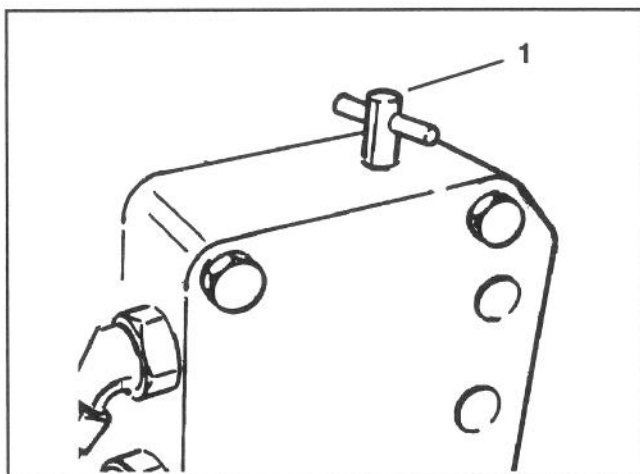

Figure 33
1. By-pass valve

2. Before starting engine, close by-pass valve securely by rotating it clockwise. Do not exceed 5–8 ft-lb torque. Do not start engine when valve is open.

TRAINING PERIOD

Before mowing with the Reelmaster 216, The Toro Company suggests you find a clear area and practice starting and stopping, raising and lowering cutting units, turning, etc. This training period will be beneficial to the operator in gaining confidence in the performance of the Reelmaster 216.

BEFORE MOWING

Inspect the area for debris and clear area if necessary. Determine the direction best to mow on the previous mowing direction. Always mow in an alternate pattern from the previous mowing, so that the grass blades will

be less apt to lay down and therefore be difficult to gather between the reel blades and bedknife.

OPERATING CHARACTERISTICS

Practice operating the Reelmaster 216 and become thoroughly familiar with it. Because of its hydrostatic transmission and choices of either two or three wheel drive (model 03430 only), its characteristics differ from many turf maintenance machines. Points to consider when operating are the traction drive, engine speed and load on the cutting units. Regulate the traction pedal to keep engine rpm high and somewhat constant while mowing to maintain adequate power for the traction and cutting units. Adjust the traction pedal stop to maintain constant ground speed and quality of cut. However, when on hilly terrain or in TRANSPORT throttle position, do not use the pedal stop.

Follow operating guidelines presented in this manual and know how to operate the machine safely on all types of terrain. Use the slope gauge, page 35, to assist in determining slope angles of questionable areas. Hills (or slopes) over 15 degrees should be traversed or mowed up and down, not side to side and hills over 20 degrees should generally be avoided unless special safeguards, skills and conditions exist. Always plan well ahead to avoid the need for sudden stops, starts or turns. To stop, use the reverse pedal for braking. Before stopping the engine, disengage all controls, move throttle to IDLE position, and set parking brake.

CAUTION: This product may exceed noise levels of 85 dB(A) at the operator position. Ear protectors are recommended for prolonged exposure to reduce the potential of permanent hearing damage.

TRANSPORT OPERATION

Be sure the cutting units are in fully up position, move traction pedal stop from under pedal to allow full traction pedal travel and place throttle control in TRANSPORT position. While operating on slopes and uneven terrain, always reduce speed and use extreme caution before turning to reduce risk of tipping or losing control. Watch carefully for, and avoid, holes in the terrain, sudden drop-offs and other hidden hazards. To prevent costly damage and down time, familiarize yourself with the width of the Reelmaster 216. Do not attempt to pass between immovable objects placed close together.

INSPECTION AND CLEAN-UP AFTER MOWING

At the completion of mowing operation, thoroughly wash the machine with a garden hose – without a nozzle – so excessive water pressure will not cause contamination and damage to seals and bearings.

OPERATING INSTRUCTIONS

Make sure cooling fins and area around engine cooling air intake are kept free of dirt or grass clippings. After cleaning, it is recommended the machine be inspected for possible hydraulic fluid leaks, damage or wear to hydraulic and mechanical components and the cutting units checked for sharpness and proper reel to bedknife adjustment.

CUTTING UNIT CHARACTERISTICS

The single knob bedknife-to-reel adjustment system incorporated in this cutting unit simplifies the adjustment procedure needed to deliver optimum mowing performance. The precise adjustment possible with the single knob/bedbar design gives the necessary control to provide a continual self-sharpening action — thus maintaining sharp cutting edges, assuring good quality-of-cut, and greatly reducing the need for routine backlapping.

In addition, the rear roller positioning system permits optimum bedknife attitude and location for varying height-of-cuts and turf conditions.

CUTTING UNIT DAILY ADJUSTMENTS

Prior to each day's mowing, or as required, each cutting unit must be checked to verify proper bedknife-to-reel contact. **This must be performed even though quality of cut is acceptable.**

1. Shut off engine and lower cutting units onto a hard surface.

2. Release belt tension to cutting units, refer to Releasing Belt Tension to Cutting Units, page 28.

3. Slowly rotate reel in reverse direction listening for reel-to-bedknife contact. If no contact is evident, turn bedknife adjusting knob clockwise, one click at a time, until light contact is felt and heard.

4. If excessive contact is felt, turn bedknife adjusting knob counterclockwise, one click at a time until no contact is evident. Then turn bedknife adjusting knob one click at a time clockwise, until light contact is felt and heard.

IMPORTANT: Light contact is preferred at all times. If light contact is not maintained, bedknife/ reel edges will not sufficiently self-sharpen and dull cutting edges will result after a period of operation. If excessive contact is maintained, bedknife/reel wear will be accelerated, uneven wear can result, and quality of cut may be adversely affected.

Note: As the reel blades continue to run against the bedknife a slight burr will appear on the front cutting edge surface the full length of the bedknife. If a file is occasionally run across the front edge to remove this burr, improved cutting can be obtained.

After extended running, a ridge will eventually develop at both ends of the bedknife. These notches must be rounded off or filed flush with cutting edge of bedknife to assure smooth operation.

LUBRICATION

GREASING BEARINGS AND BUSHINGS

(Fig. 34-41)

The traction unit and cutting unit's grease fittings must be lubricated regularly with No. 2 General Purpose Lithium Base Grease. If machine is operated under normal conditions, lubricate bearings and bushings after every 25 hours of operation. Bearings and bushings must be lubricated daily when operating conditions are extremely dusty and dirty. Dusty and dirty operating conditions could cause dirt to get into the bearings and bushings, resulting in accelerated wear.

The traction unit bearings and bushings that must be lubricated are:

Steering column (Fig. 34), steering shaft (2) (Under skirt below steering sector), rear castor fork (Fig. 35), jackshaft pulley bearing (2) (Fig. 36), lift arms (3) (Fig. 37) pivot rods (3) (Fig. 38), and belt tensioner (Fig. 39).

The cutting unit lubrication points are: Single point adjustment knob (2) (Fig. 40), reel flange bearing (2) and front and rear rollers (Fig. 41).

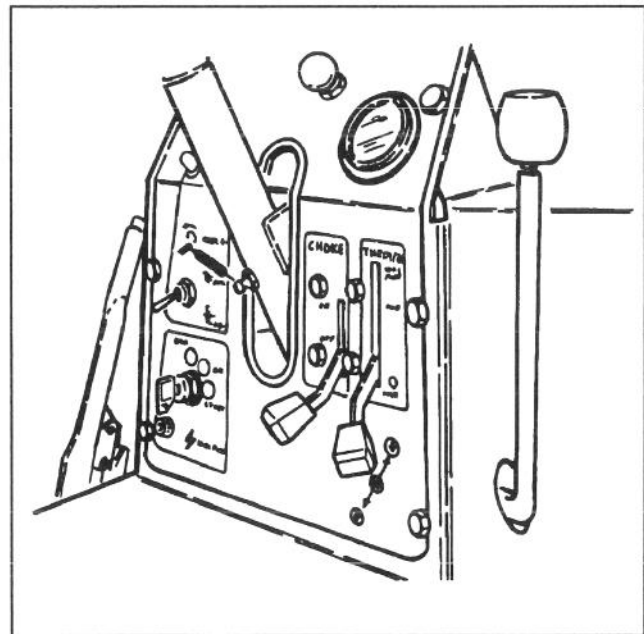

Figure 34

LUBRICATION

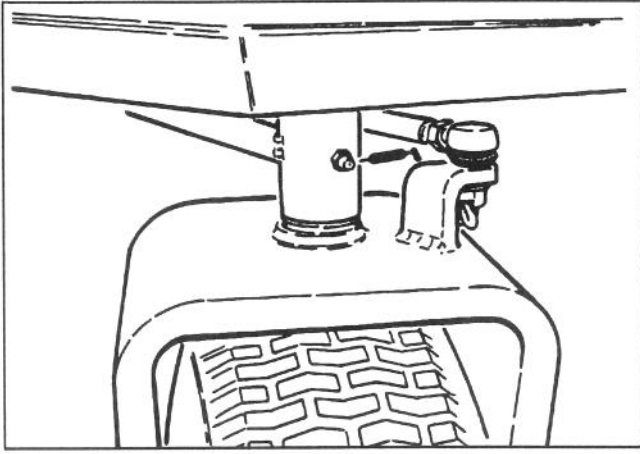

Figure 35

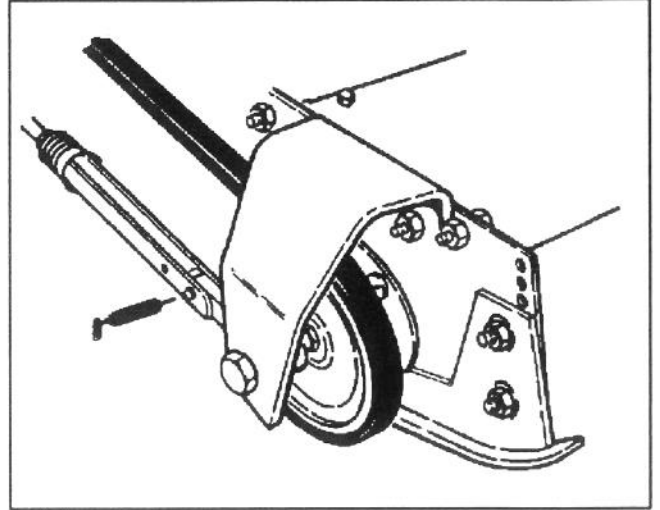

Figure 39

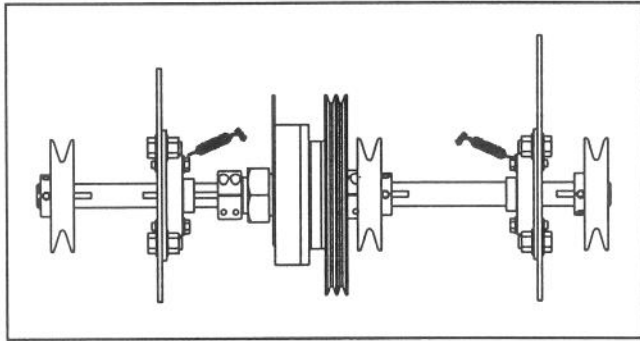

Figure 36

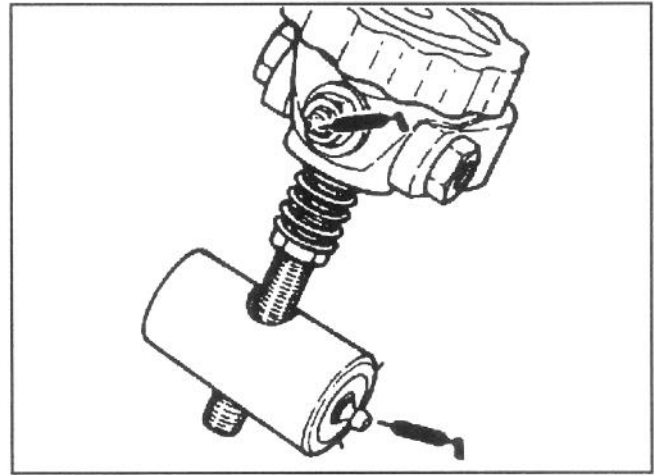

Figure 40

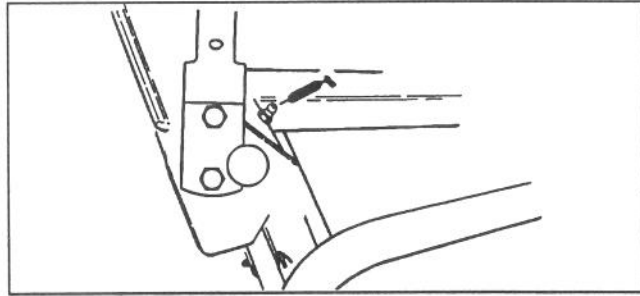

Figure 37

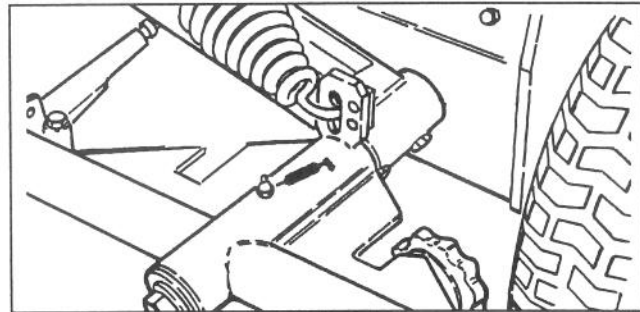

Figure 38

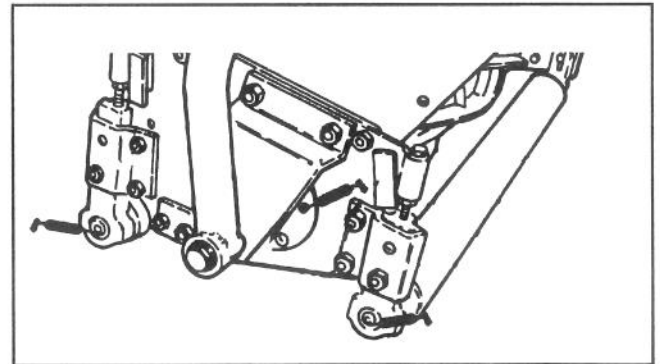

Figure 41

MAINTENANCE



CAUTION

Before servicing or making adjustments to the machine, stop engine and remove key from the switch.

CHANGING CRANKCASE OIL (Fig. 42)

For new engines, change oil after first 5 operating hours. Thereafter, under normal conditions, change oil after every 25 hours of engine operation. However, an engine operated in dusty or dirty conditions requires more frequent oil changes. If possible, run engine just before changing oil. Warm oil flows more freely and carries more contaminants than cold oil.

1. Place an oil drain pan below the drain plug on rear of crankcase. Clean area around drain plug.
2. Remove drain plug and allow oil to flow into drain pan. After oil is drained, reinstall oil drain plug.

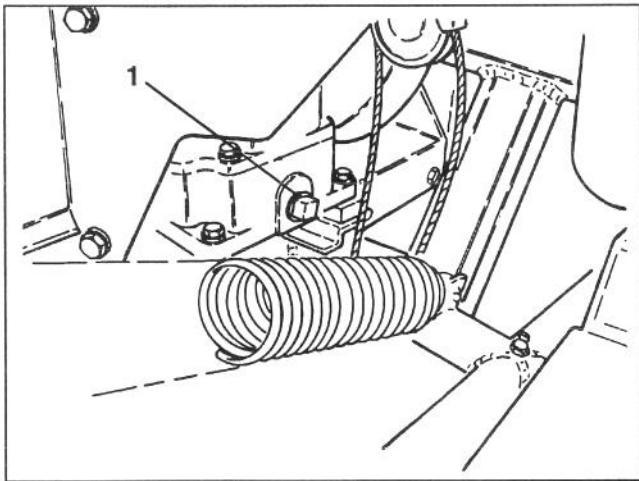

Figure 42
1. Crankcase drain plug

3. Remove dipstick / filler cap and pour approximately 5–1/4 pints of oil having the API "service classification" SE or SF into the filler neck. Oil viscosity — weight — is selected according to anticipated ambient temperature. Temperature/ viscosity recommendations are:

A. Above 32° F (0° C) — Use SAE 30. The use of multi-weight oil above 32° F (0° C) is not recommended due to increased oil consumption and excessive combustion chamber deposits.

B. Below 32° F (0° C) — Use SAE 5W–20 or 5W–30, and if they are not available, 10W–30 or 10W–40 are acceptable substitutes.

4. Check oil and make sure level is up to the FULL mark on dipstick. Add more oil if level is low; however, DO NOT OVERFILL.

SERVICING AIR CLEANER (Fig. 43–44)

The foam pre-cleaner must be cleaned and re-oiled after every 25 hours engine operation if engine is operated in clean air conditions. However, air cleaner must be cleaned every few hours if operating conditions are extremely dusty or sandy.

1. Remove lock nut and cover.

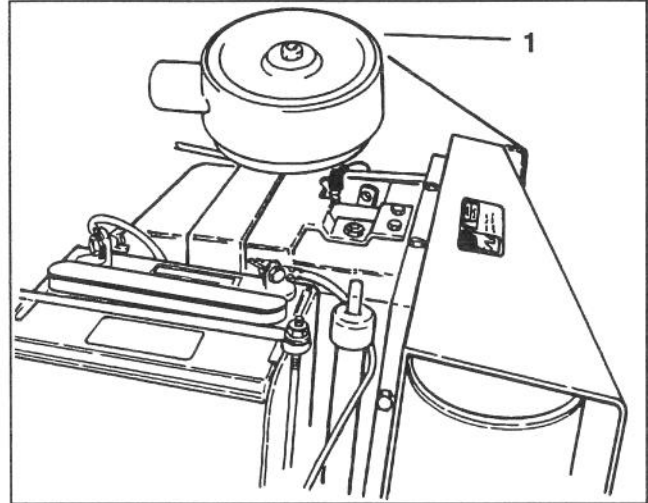

Figure 43
1. Air cleaner cover

2. Remove foam pre-cleaner by sliding it off the paper element.
3. A. Wash foam pre-cleaner in detergent and warm water.
B. Wrap foam pre-cleaner in cloth and squeeze dry. Do not wring pre-cleaner.
C. Saturate foam pre-cleaner in engine oil. Squeeze to remove excess oil.

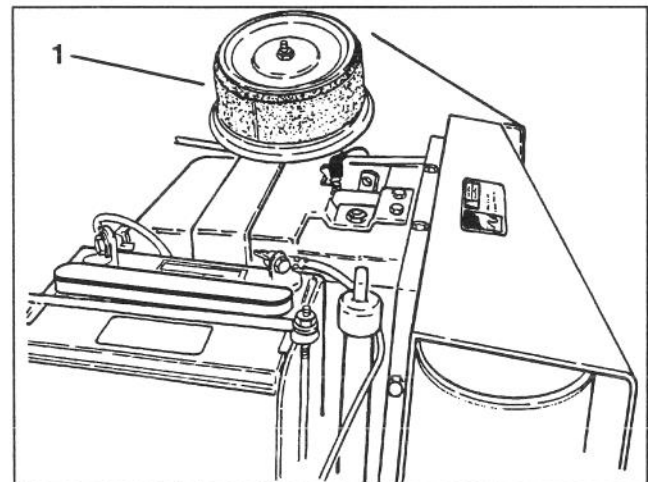

Figure 44
1. Foam pre-cleaner

4. Reinstall on paper cartridge.

MAINTENANCE

Inspect paper element every 50 hours of operation and replace when dirty or damaged. Do not wash paper element or do not clean with compressed air as damage will occur.

Note: With air cleaner disassembled, check air cleaner components for damage. Replace if necessary. Make sure rubber breather tube in base plate is securely in place or severe engine damage may occur.

5. Reinstall element with pre-cleaner, element cover seal, air cleaner element cover, nut, air cleaner cover and lock nut.

6. Tighten lock nut 1/2 to 1 turn after nut contacts cover. Do not overtighten.

ADJUSTING CARBURETOR (Fig. 45)

Lack of power accompanied by black sooty exhaust smoke is usually caused by a rich carburetor setting. Since a dirty air cleaner element causes the same conditions, check it before adjusting carburetor.

High RPM Setting — 3600 \pm 100

Low RPM Setting — 1200 \pm 100

IMPORTANT: Check to make sure the choke is operating correctly before the carburetor is adjusted.

1. Main fuel screw — Close screw by gently rotating it clockwise.

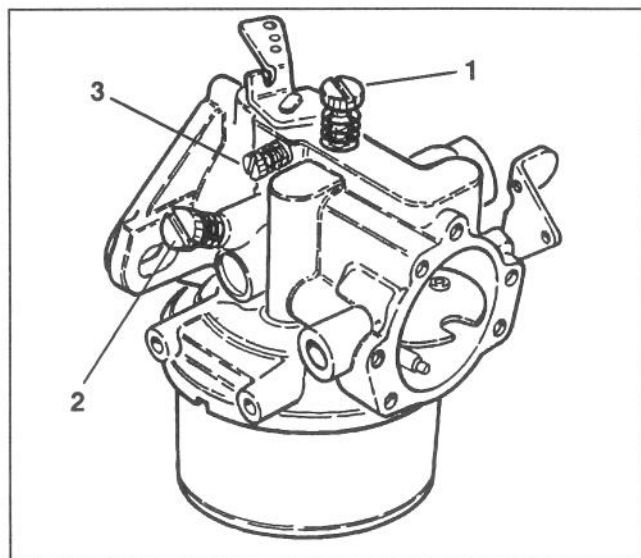

Figure 45

1. Main fuel screw
2. Idle fuel adjusting screw
3. Idle speed screw

IMPORTANT: Do not close the screw too tightly because the screw will likely be damaged.

2. Rotate — open the main fuel screw 3–1/2 turns counterclockwise.

3. Idle fuel adjusting screw— Close screw by gently rotating it clockwise. Open screw by rotating it 2–1/2 turns counterclockwise.



WARNING

Engine must be running so final adjustment of the carburetor can be performed. To guard against possible personal injury, keep hands, feet, face and other parts of the body away from the muffler, other hot parts of the engine, and other moving or rotating parts of the engine. Assure reel switch is in DISENGAGE position and cutting units are on the shop floor. Also engage parking brake.

IMPORTANT: Do not close the screw too tightly because the screw will likely be damaged.

Note: These settings are approximate; however, the settings will allow engine to be started so carburetor can be fine tuned — steps 4–7.

4. Start engine and let it run for 5–10 minutes at half throttle to warm up. Engine must be warm before making final adjustments.

5. Move throttle to TRANSPORT position. Turn main fuel screw in until speed decreases and note position of screw. Now turn screw out — the engine speed may first increase, then it will decrease as screw is turned. Note the position of screw when engine speed starts to decrease. Set the screw at the midpoint of the two positions noted.

6. To adjust idle fuel adjusting screw, follow same procedure as for main fuel but move throttle to IDLE after 5–10 minute warm up and make adjustment.

7. Idle Speed Setting — Run engine at half-throttle for 5–10 minutes to warm up. Move throttle to IDLE and set engine speed to 1200 RPM by turning the idle speed adjusting screw clockwise or counterclockwise.

CHECKING AND REPLACING SPARK PLUG (Fig. 46)

Since air gap between center and side electrodes increases gradually during normal engine operation, check condition of electrodes at 100 hour intervals. The correct spark plug for the engine is Champion RH–10 or equivalent. Set air gap at .025 in.

1. Clean area around spark plug so dirt does not fall into cylinder when plug is removed.

2. Pull wire off spark plug and remove plug from cylinder head.

MAINTENANCE

3. Check condition of center and side electrodes to determine operating temperature of engine.

A. Light brown insulator tip indicates correct spark plug and heat range.

B. Black or oily insulator tip indicates an excessively rich fuel mixture, possibly caused by a dirty air cleaner element or a carburetor that is set too rich.

C. Light gray or blistered–white insulator indicates overheating caused by a lean carburetor setting or incorrect spark plug (heat range too high).

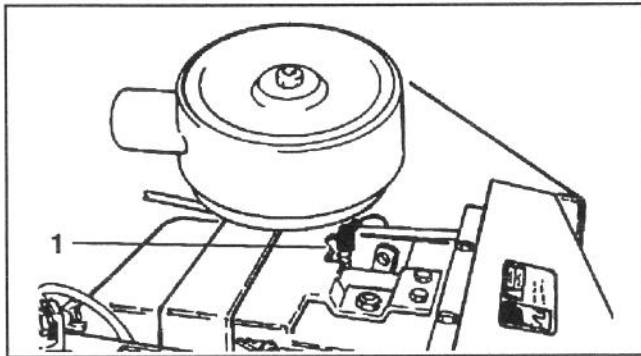

Figure 46
1. Spark plug

IMPORTANT: A cracked, fouled or dirty spark plug must be replaced. Do not sandblast, scrape or clean electrodes by using a wire brush because grit may release from the plug and enter combustion chamber resulting in engine damage.

4. After setting air gap at .025", install spark plug in cylinder head. Tighten the plug to 10–15 ft–lb. Push wire onto spark plug.

CLEANING CYLINDER HEAD FINS

To avoid overheating and possible engine damage, cooling fins on cylinder head must be kept clean.

CHANGING HYDRAULIC SYSTEM FLUID AND FILTER

The hydraulic system filter must be changed initially, after the first five hours of operation, and thereafter every 250 hours of operation or yearly, whichever comes first. Use a genuine Toro oil filter for replacement. The hydraulic fluid must be changed every 500 hours of operation or yearly, whichever comes first.

1. Park the machine on a level surface, lower the cutting units, set parking brake and turn the engine off.
2. If only the filter is to be changed, remove reservoir cap and insert reservoir plug (Fig. 47), to block outlet.

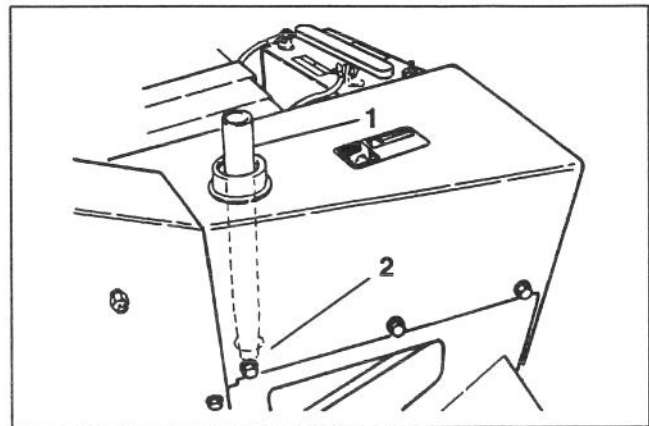

Figure 47
1. Reservoir plug
2. Reservoir outlet

This will retain most of the fluid in reservoir when filter is removed.

3. Clean the area around the hydraulic oil filter. Remove filter from the bottom of the filter housing and allow the oil to flow into a drain pan. Use bottom type filter wrench. Dispose of the oil filter properly.

4. Apply a film of oil on the filter gasket. Install filter by hand until gasket contacts mounting head; then tighten filter an additional three–fourths turn.

5. Fill the reservoir to proper level, refer to Check Hydraulic System Fluid, page 17.

6. Place all controls in neutral or disengaged position and start engine. Run engine at lowest possible RPM to purge the system of air.

7. Run engine until lift cylinder extends and retracts and forward and reverse wheel motion is achieved.

8. Stop the engine and check the oil level in reservoir, add oil if necessary.

9. Check all connections for leaks.

REPLACING FUEL FILTER

An in–line filter is incorporated into the fuel line. Use the following procedures should replacement become necessary:

1. Close fuel shut–off valve.
2. Clamp both fuel lines that connect to the fuel filter so gasoline cannot drain when lines are removed.



CAUTION

Since gasoline is highly flammable, drain it outdoors and make sure engine is cool to prevent a potential fire hazard. Wipe up any gasoline that may have spilled. Do not drain gasoline near any open flame or where gasoline fumes may be ignited by a spark. Do not smoke a cigar, cigarette, or a pipe when handling gasoline.

MAINTENANCE

3. Loosen the hose clamps at both ends of the filter and pull fuel lines off filter.

4. Slide hose clamps onto ends of fuel lines. Push fuel lines onto fuel filter and secure them with hose clamps. Be sure arrow on side of filter points toward the carburetor.

ADJUSTING TRANSMISSION FOR NEUTRAL (Fig. 48)

If the machine "creeps" when the traction control pedal is in the neutral position, the spring leaf assembly must be adjusted.

1. Block up under the frame so one of the front wheels is off the floor. Place selector control in two wheel drive position.

2. Start engine, move throttle to SLOW and check front wheel that is off shop floor; it must not be rotating. If wheel is rotating forward, loosen capscrews and lightly tap bottom of pump plate counterclockwise. By contrast, tap pump plate clockwise if wheel is rotating backward. When wheel stops rotating, tighten capscrews holding pump plate against side of pump. Verify the adjustment with throttle in SLOW and FAST position.

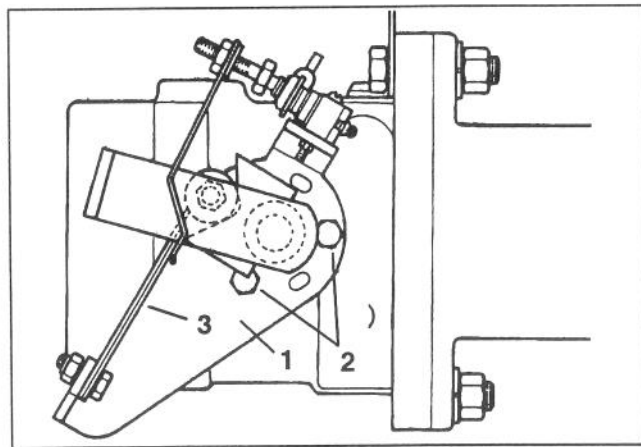

Figure 48

- 1. Pump plate
- 2. Capscrews
- 3. Leaf springs

3. Should the wheel continue to rotate, check for the following:

- A. Ball bearing is loose or worn out.
- B. Plunger on interlock switch is sticking.
- C. Loose or missing fasteners.
- D. Worn fasteners.
- E. Pump lever loose on control shaft. (Correct by applying Loctite 271 or 601 to shaft).
- F. Weak or damaged leaf springs. Replace.
- G. Internal pump component malfunction.

BELT ADJUSTMENTS

Make sure belts are properly tensioned to assure proper operation of the machine and prevent unnecessary wear. Check all belts midway in span of belt. Check belts frequently.

Hydraulic Pump Belt (Fig. 49)

1. Tighten nut on adjustment rod until desired belt tension is attained.

Note: Tighten belt to eliminate slippage (squealing under load) but do not overtighten.

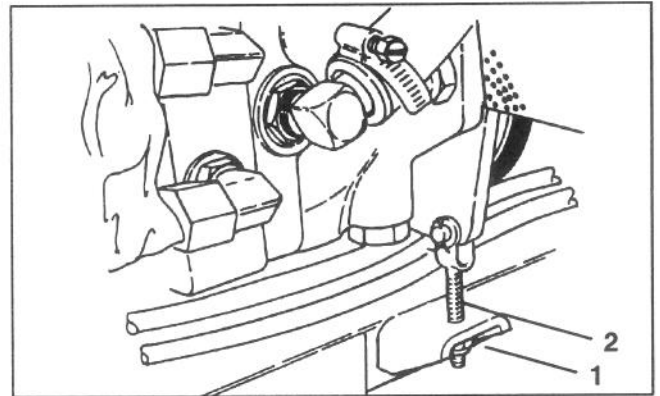

Figure 49

- 1. Nut
- 2. Adjustment rod

Engine/Clutch To Jack Shaft Belt

1. Make sure the idler bracket and belt tensioner assembly are free to move.

2. Adjust nut on belt tensioner (left side of engine) to compress spring to a length of 3/4".

Cutting Unit Drive Belts (Fig. 50)

1. The cutting unit drive belts should have a maximum deflection of 1/2 inch with a 10 pound load applied.

2. Loosen jam nut on front end of belt tension rod. Rotate rod to lengthen or shorten rod to desired length. Tighten jam nut.

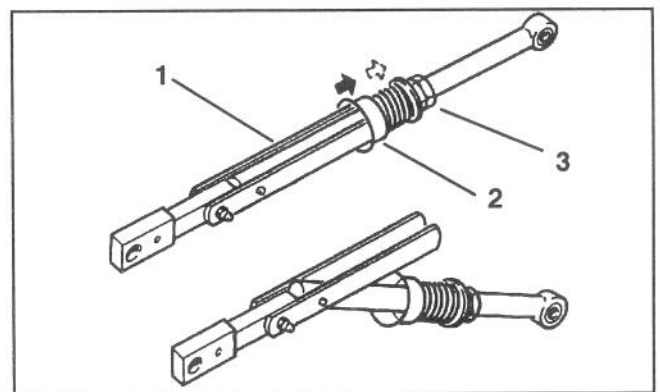

Figure 50

- 1. Belt tension rod
- 2. Belt tension rod cup retainer
- 3. Jam nut

MAINTENANCE

3. To release belt tension to cutting units, push retaining cup rearward and pivot yoke downward .

ADJUSTING STEERING STOPS (Fig. 51)

To increase or decrease the turning radius of the machine, steering stop screws may be adjusted.

1. Loosen locknuts securing stop screws to tabs on steering sector.

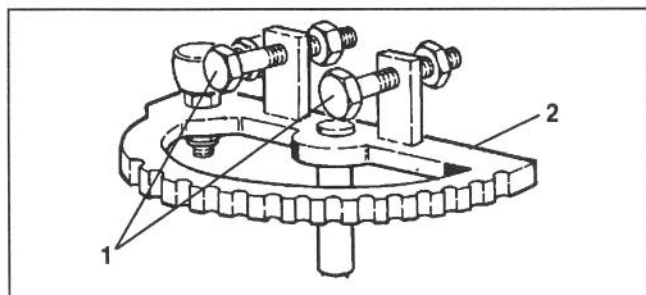

Figure 51
1. Stop screws
2. Steering sector

2. Thread stop screws in or out until desired turning radius is attained.

3. Check adjustment and retighten locknuts.

ADJUSTING TRACTION PEDAL (Fig. 52-53)

If traction pedal contacts footrest when pushed fully forward or maximum forward traction speed is unattainable, an adjustment to the traction pedal linkage is required. There should be 3/4 inch clearance between pedal shaft and footrest when pedal is pushed fully forward.

1. Remove (3) self tapping screws securing support screen to hydraulic support panel. Remove screen.

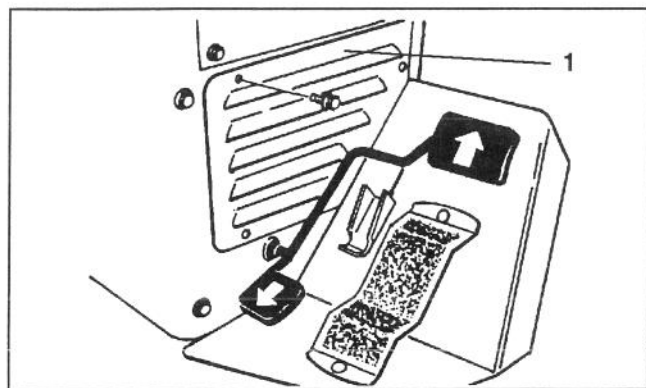

Figure 52
1. Support screen

2. Loosen jam nuts on each end of traction rod.

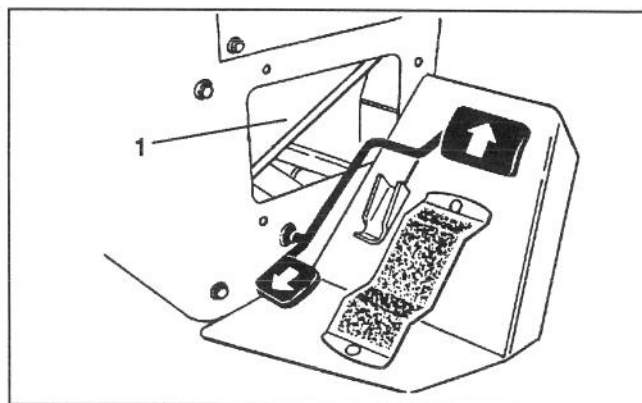

Figure 53
1. Traction rod

3. Rotate rod until 3/8" dimension between traction pedal shaft and footrest is attained.

4. Retighten jam nuts securing traction rod and reinstall support screen.

5. The stop for reverse travel (under pedal) may be adjusted for slower travel. Speeds in excess of 3 M.P.H. are not recommended.

HAND BRAKE ADJUSTMENT (Fig. 54)

1. Remove both front wheels.

2. Make sure brake is in the OFF position.

3. Loosen jam nut on clevis. Remove cotter pin securing top of clevis to upper brake lever. Rotate clevis, one turn at a time, to decrease distance between levers.

Note: If adjustment is unattainable due to lack of thread on clevis, reposition lower brake lever on shaft.

4. Reinstall clevis to upper brake lever and tighten jam nut. Repeat procedure on opposite side of machine.

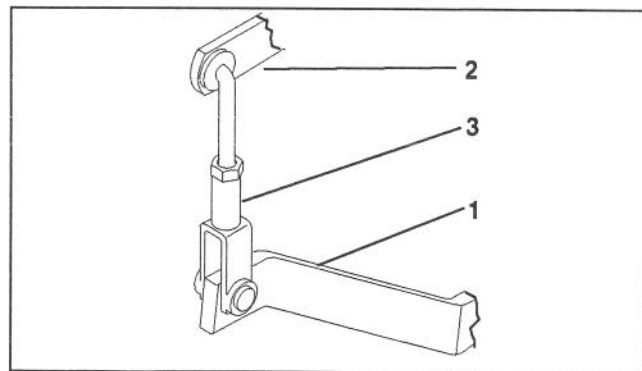

Figure 54
1. Lower brake lever
2. Upper brake lever
3. Clevis

5. After any brake adjustment, operate the vehicle at a low speed (one mph or less) and check that brakes engage equally on both wheels. Readjust as necessary.

ADJUSTING CLUTCH

The clutch is adjustable to ensure proper engagement.

1. To adjust clutch, tighten or loosen locknuts on flange studs.

MAINTENANCE

2. Check adjustment by inserting feeler gauge through slots next to flanged studs.

3. The proper disengaged clearance between the clutch plates is .009 – .012 inches. It will be necessary to check this clearance at each of the three slots to ensure the plates are parallel to each other and equal at all (3) locations.

ADJUST HOOD LATCH

1. To adjust hood latch, loosen jam nuts on hood latch release lever and reposition in slot in control panel as required and/or loosen screws securing latch on hood and reposition as required.

BATTERY STORAGE

If the machine will be stored more than 30 days, remove the battery and charge it fully. Either store it on the shelf on the machine. Leave the cables disconnected if stored on the machine. Store the battery in a cool atmosphere to avoid quick deterioration of the charge in the battery. To prevent battery from freezing, make sure it is fully charged. The specific gravity of a fully charged battery is 1.250.

BATTERY CARE

1. Battery electrolyte level must be properly maintained and the top of the battery kept clean. If the machine is stored in a location where temperatures are extremely high, the battery will run down more rapidly than if the machine is stored in a location where temperatures are cool.

2. Check the electrolyte level every 25 operating hours or, if machine is in storage, every 30 days.

3. Maintain cell level with distilled or demineralized water. Do not fill cells above the bottom of the split ring inside each cell.

4. Keep top of battery clean by washing periodically with a brush dipped in ammonia or bicarbonate of soda solution. Flush the top surface with water after cleaning. Do not remove the fill cap while cleaning.

5. Battery cables must be tight on terminals to provide good electrical contact.

6. If corrosion occurs at terminals, disconnect cables, negative (–) cable first and scrape clamps and terminals separately. Reconnect cables, positive (+) cable first and coat terminals with petroleum jelly.



WARNING

Connecting cables to the wrong post could result in personal injury and/or damage to the electrical system.



CAUTION

Wear safety goggles and rubber gloves when working with electrolyte. Charge the battery in a well ventilated place so gases produced while charging can dissipate. Since the gases are explosive, keep open flame and electrical spark away from the battery; do not smoke. Nausea may result if the gases are inhaled. Unplug charger from electrical outlet before connecting to, or disconnecting, charger leads from battery posts.

BACKLAPPING CUTTING UNITS

The cutting units may be backlapped on the machine.

Backlap Kit, Part no. 84–5510 is available from your Authorized TORO Distributor.

Backlap according to procedures in the Toro Sharpening Reel and Rotary Mowers Manual Form No. 80–300 PT.



CAUTION

Be careful when lapping the reel because contact with the reel or other moving parts can result in personal injury.



DANGER

Under no circumstances use a short handled paint brush. 29–9100 Handle assembly complete, or individual parts, are available from your local Authorized TORO Distributor.

HYDRAULIC SCHEMATIC-2 WD (MODEL 03410)

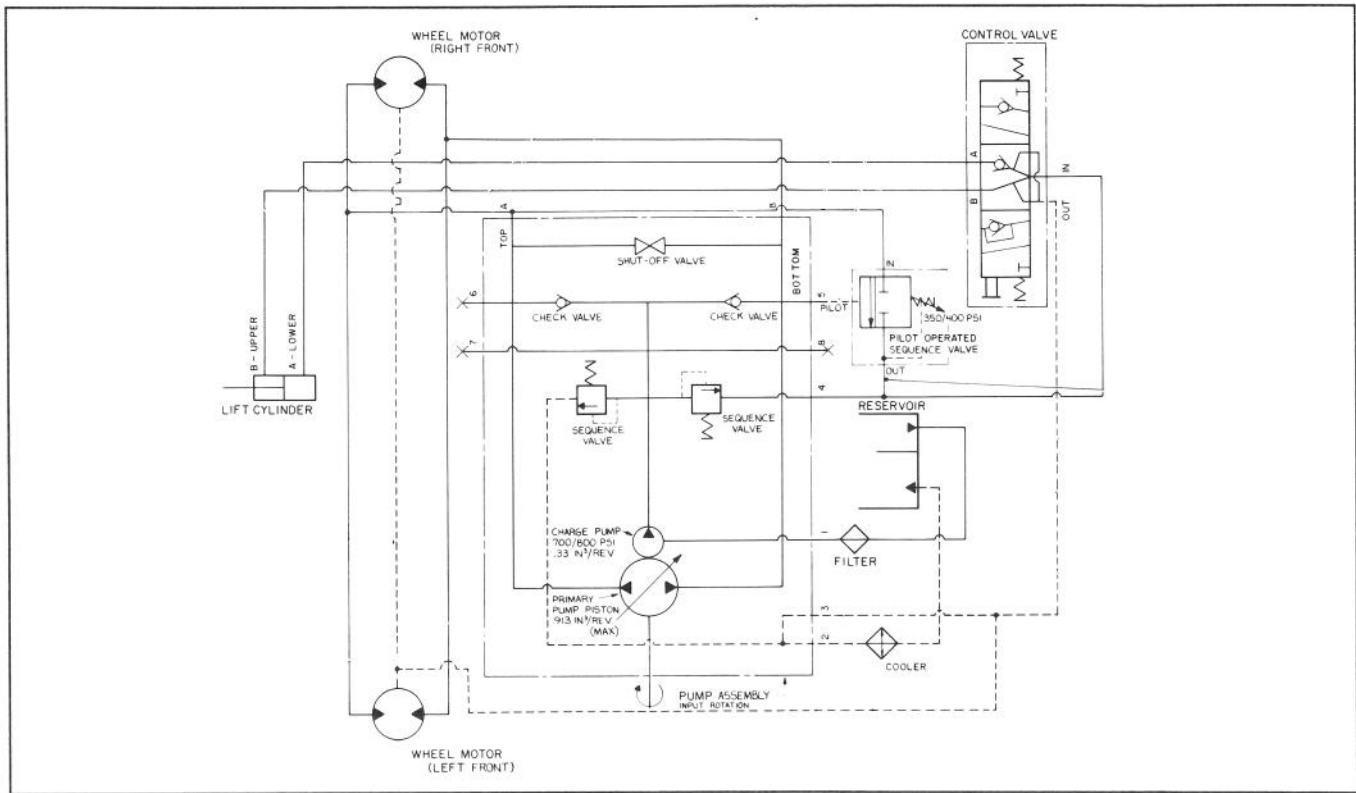

HYDRAULIC SCHEMATIC-3 WD (MODEL 03430)

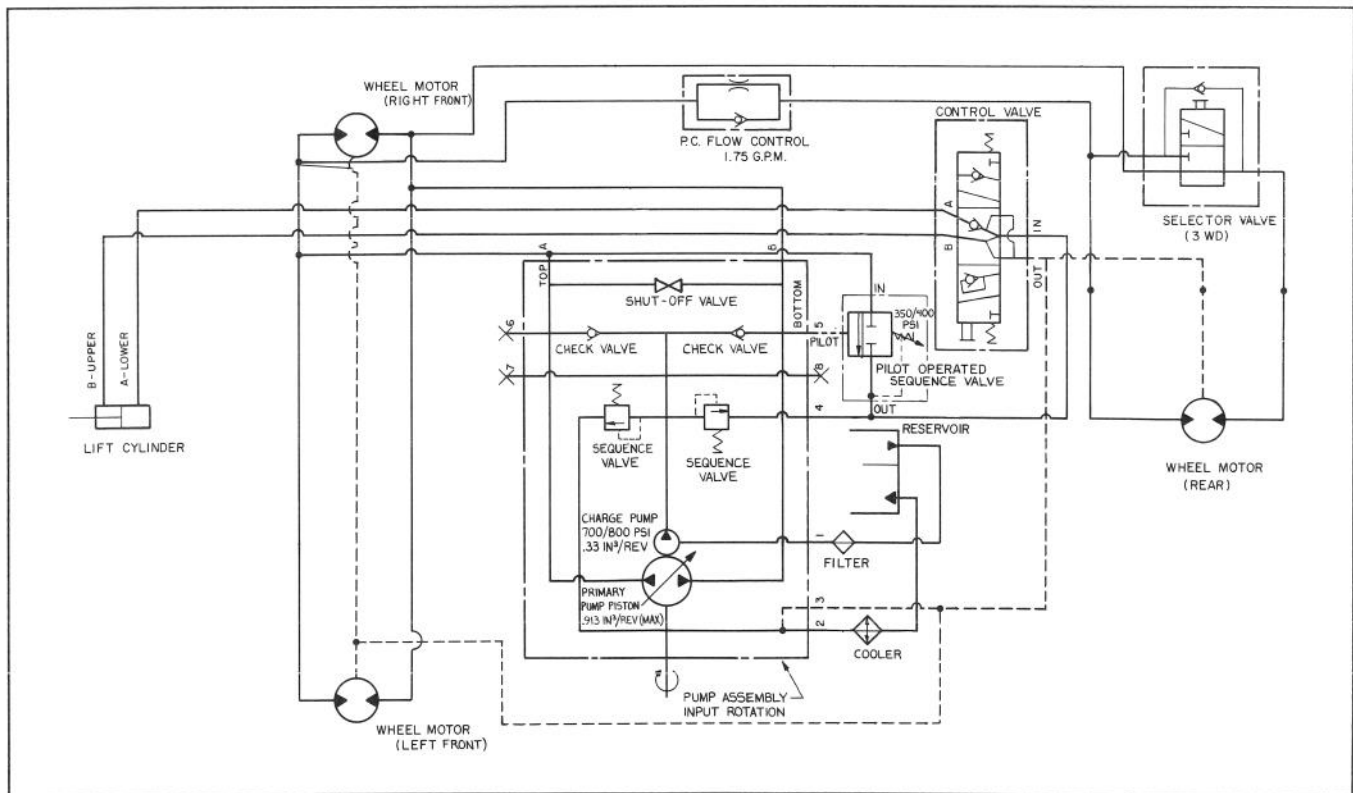

ELECTRICAL SCHEMATIC

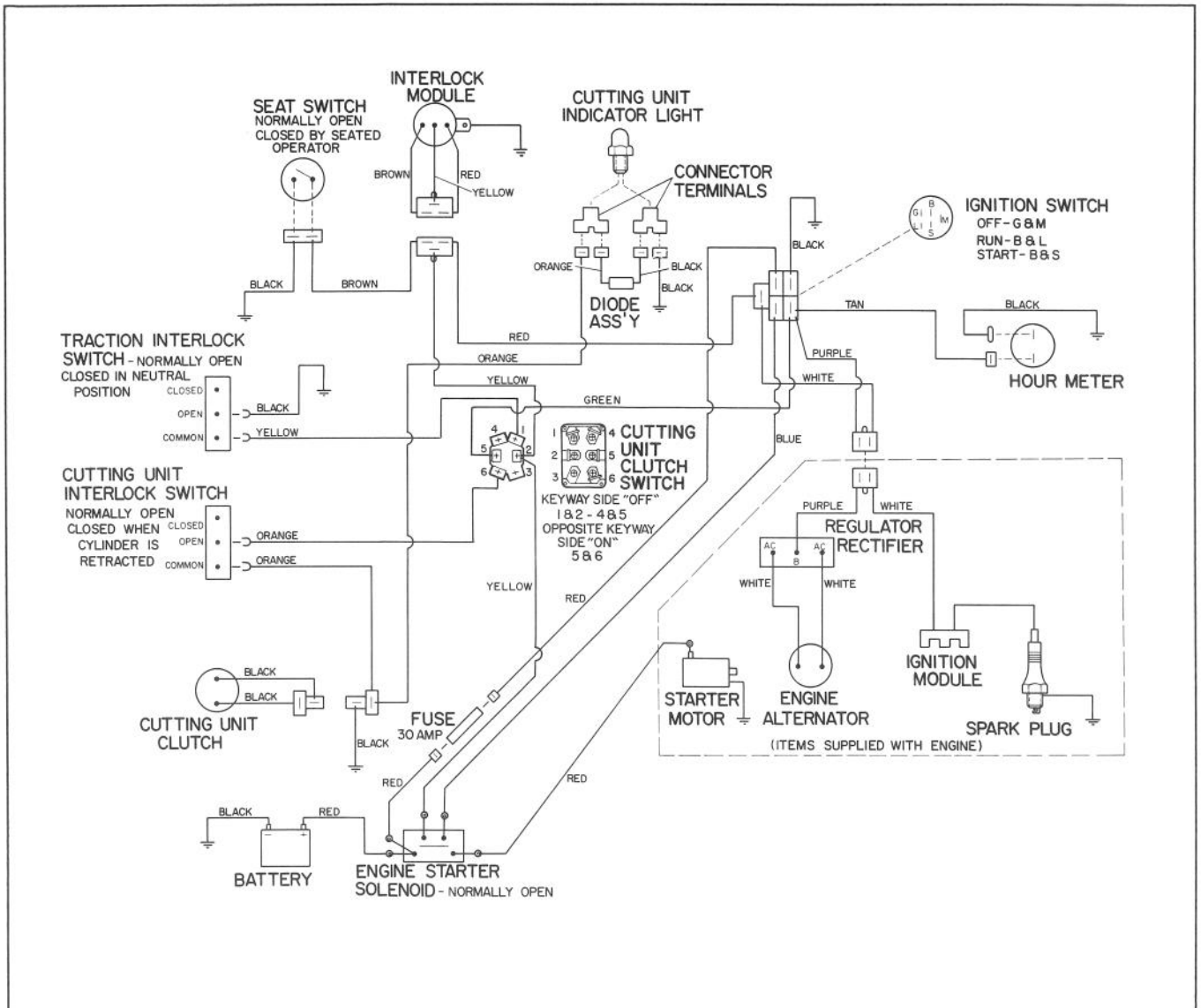

IDENTIFICATION AND ORDERING

MODEL AND SERIAL NUMBER

The mower has two identification numbers: a model number and a serial number. The two numbers are stamped into a plate that is riveted to the frame at rear of mower. In any correspondence concerning the mower, supply the model and serial numbers to assure that correct information and replacement parts are obtained.

Note: Do not order by reference number if a parts catalog is being used; use the part number.

To order replacement parts from an Authorized TORO Service Dealer, supply the following information:

1. Model and serial numbers of the mower.
2. Part number, description and quantity of part(s) desired.

15° AND 20° SLOPE CHART

Read all safety decals and safety instructions in this manual .

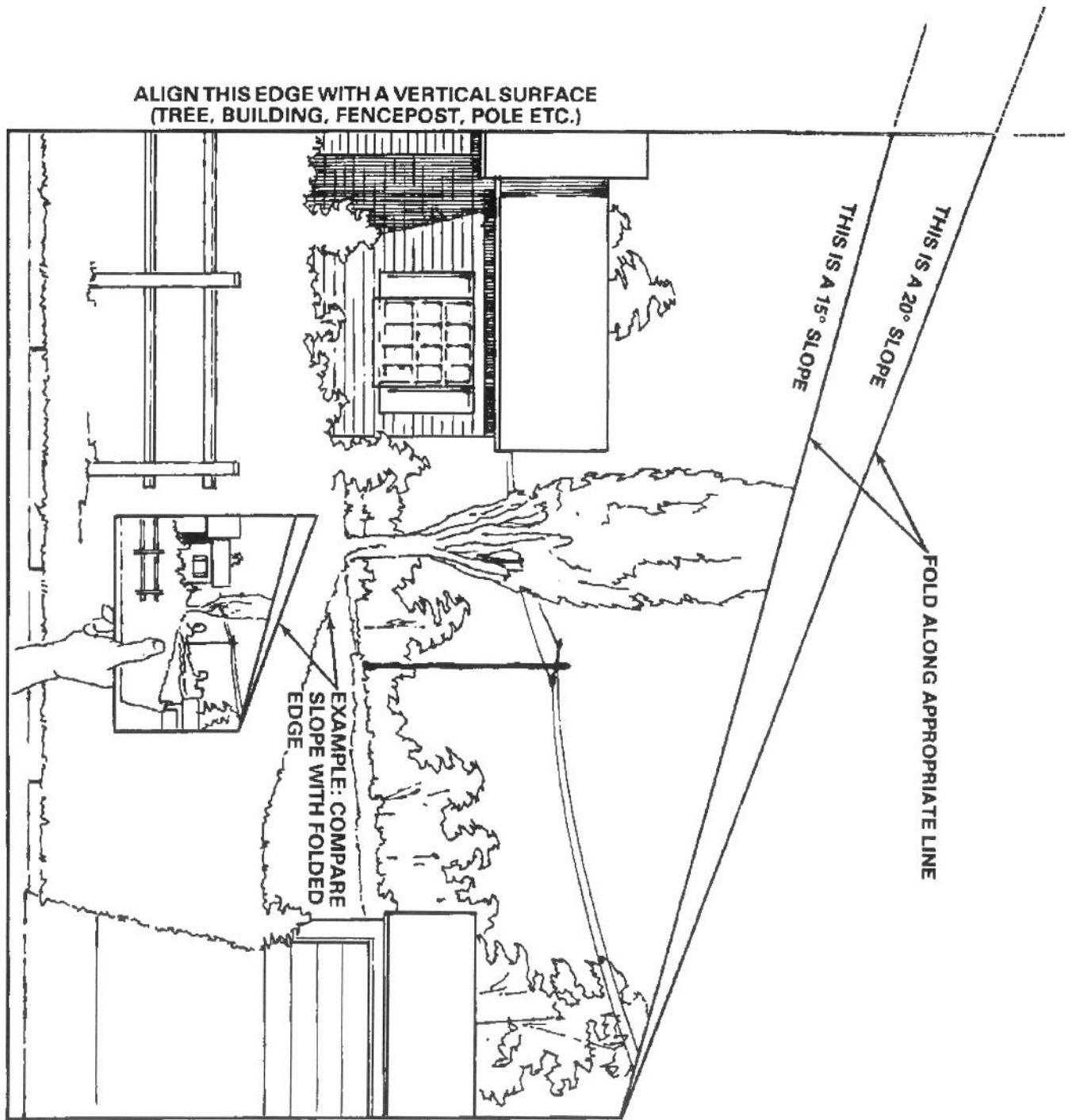

The Toro Promise

A ONE YEAR LIMITED WARRANTY

The Toro Company promises to repair your TORO Reelmaster 216-D if defective in materials or workmanship. The following time periods from the date of purchase apply:

Commercial Products 1 Year*
*Cutting unit drive belts..... Two years or 1500 operational hours

The costs of parts and labor are included, but the customer pays the transportation costs on walk rotary mowers with cutting unit widths of less than 25".

If you feel your TORO product is defective and wish to rely on The Toro Promise, the following procedure is recommended:

1. Contact your Authorized TORO Distributor or Commercial Dealer (the Yellow Pages of your telephone directory is a good reference source).
2. The TORO Distributor or Commercial Dealer will advise you on the arrangements that can be made to inspect and repair your product.
3. The TORO Distributor or Commercial Dealer will inspect the product and advise you whether the product is defective and, if so, make all repairs necessary to correct the defect without an extra charge to you.

If for any reason you are dissatisfied with the distributor's analysis of the defect or the service performed, you may contact us.

Write:

TORO Commercial Products Service Department
8111 Lyndale Avenue South
Minneapolis, Minnesota 55420

The above remedy of product defects through repair by an Authorized TORO Distributor or Commercial Dealer is the purchaser's sole remedy for any defect.

THERE IS NO OTHER EXPRESS WARRANTY. ALL IMPLIED WARRANTIES OF MERCHANTABILITY AND FITNESS FOR USE ARE LIMITED TO THE DURATION OF THE EXPRESS WARRANTY.

Some states do not allow limitations on how long an implied warranty lasts, so the above limitation may not apply to you.

This Warranty applies only to parts or components which are defective and does not cover repairs necessary due to normal wear, misuse, accidents, or lack of proper maintenance. Regular, routine maintenance of the unit to keep it in proper condition is the responsibility of the owner.

All warranty repairs reimbursable under the Toro Promise must be performed by an Authorized TORO Commercial Dealer or Distributor using Toro approved replacement parts.

Repairs or attempted repairs by anyone other than an Authorized TORO Distributor or Commercial Dealer are not reimbursable under the Toro Promise. In addition, these unauthorized repair attempts may result in additional malfunctions, the correction of which is not covered by warranty.

THE TORO COMPANY IS NOT LIABLE FOR INDIRECT, INCIDENTAL OR CONSEQUENTIAL DAMAGES IN CONNECTION WITH THE USE OF THE PRODUCT INCLUDING ANY COST OR EXPENSE OF PROVIDING SUBSTITUTE EQUIPMENT OR SERVICE DURING PERIODS OF MALFUNCTION OR NON-USE.

Some states do not allow the exclusion or limitation of incidental or consequential damages, so the above limitation or exclusion may not apply to you.

This warranty gives you specific legal rights, and you may also have other rights which vary from state to state.

COUNTRIES OTHER THAN THE UNITED STATES OR CANADA

Customers who have purchased TORO products exported from the United States or Canada should contact their TORO Distributor (Dealer) to obtain guarantee policies for your country, province or state. If for any reason

you are dissatisfied with your Distributor's service or have difficulty obtaining guarantee information, contact the TORO importer. If all other remedies fail, you may contact us at The Toro Company.