



# Eductor Kit

## Multi-Pro 5800 Turf Sprayer

Model No. 41612—Serial No. 314000001 and Up

### Installation Instructions

This kit is designed to aid in the mixing of chemicals in preparation for turf spray applications on well-maintained lawns in parks, golf courses, sports fields, and on commercial grounds. It is a dedicated attachment for a turf spray application vehicle and is intended to be used by professional, hired operators in commercial applications.

This product complies with all relevant European directives; for details, please see the separate product specific Declaration of Conformity (DOC) sheet.

Read this manual carefully to learn how to operate and maintain your product properly. The information in this manual can help you and others avoid injury and product damage. Although Toro designs and produces safe products, you are responsible for operating the product properly and safely.

You may contact Toro directly at [www.Toro.com](http://www.Toro.com) for product and accessory information, help finding a dealer, or to register your product.

Whenever you need service, genuine Toro parts, or additional information, contact an Authorized Service Dealer or Toro Customer Service and have the model and serial numbers of your product ready. Figure 1 illustrates the location of the model and serial numbers on the product.

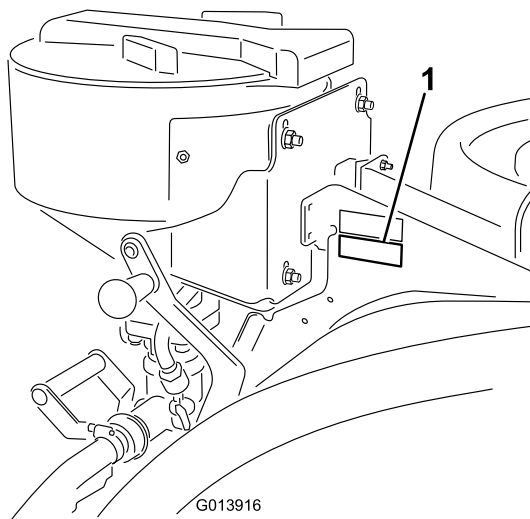

**Figure 1**

1. Model and serial number plate

**▲ WARNING**

**CALIFORNIA  
Proposition 65 Warning**

**This product contains a chemical or chemicals known to the State of California to cause cancer, birth defects, or reproductive harm.**

**Use of this product may cause exposure to chemicals known to the State of California to cause cancer, birth defects, or other reproductive harm.**

**Model No.** \_\_\_\_\_

**Serial No.** \_\_\_\_\_



# Safety

This manual identifies potential hazards and has safety messages identified by the safety alert symbol (Figure 2), which signals a hazard that may cause serious injury or death if you do not follow the recommended precautions.



Figure 2

1. Safety alert symbol

---

This manual uses 2 words to highlight information.

**Important** calls attention to special mechanical information and **Note** emphasizes general information worthy of special attention.

## ⚠ WARNING

Chemical substances used in the spray system may be hazardous and toxic to you, bystanders, animals, plants, soils, or other property.

- Carefully read and follow the chemical warning labels and Material Safety Data Sheets (MSDS) for all chemicals used, and protect yourself according to the chemical manufacturer's recommendations. For example, use appropriate Personal Protective Equipment (PPE), including face and eye protection, gloves, or other equipment to guard against personal contact with the chemical.
- Keep in mind that there may be more than 1 chemical used, and information on each chemical should be assessed.
- Refuse to operate or work on the sprayer if this information is not available!
- Before working on a spray system, make sure that the system has been triple rinsed and neutralized according to the recommendations of the chemical manufacturer(s).
- Verify that there is an adequate supply of clean water and soap nearby, and immediately wash off any chemicals that contact you.

## Safety and Instructional Decals



Safety decals and instructions are easily visible to the operator and are located near any area of potential danger. Replace any decal that is damaged or lost.

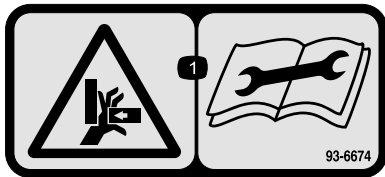

93-6674

1. Crushing hazard, hand—read the instructions before servicing or performing maintenance.

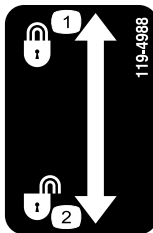

119-4988

1. Lock
2. Unlock

# Installation

## Loose Parts

Use the chart below to verify that all parts have been shipped.

Procedure	Description	Qty.	Use
<b>1</b>	Eductor valve assembly	1	Install the eductor valve.
	O-ring	1	
	Bolt (M8 –1.25 x 146 mm)	4	
	Bracket (Bracket may already be installed from a previous kit installation)	1	
<b>2</b>	Support frame assembly	1	Assemble the frame.
	Locknut (3/8 inch)	1	
	Back plate assembly	1	
	Cradle arm, right	1	
	Cradle arm, left	1	
	Bushing	2	
	Pivot pin	2	
	Jam nut (3/8 inch)	2	
	Handle	2	
	Bolt (3/8 x 1-1/4 inches)	2	
	Set screw	2	
	Hair pin	2	
	Flat washer	2	
<b>3</b>	Spring	2	Install the latching components.
<b>4</b>	Eductor	1	Install the eductor.
	Handle	1	
	Flange-head bolt	2	
	Spring clamp	1	
	Bolt (#10-24 x 1/2 inch)	2	
	Locknut (#10-24)	2	
	Bolt (3/8 x 1 inch)	4	
	Locknut (3/8 inch)	4	
	Flange-head nut	2	
	Hex-head bolt	3	
	Latch post	1	
	Latch handle	1	
	T-valve	1	
	Gasket	1	
Worm-screw clamp	1		
<b>5</b>	Bulkhead	1	Install the forward hose.
	O-ring	1	
	Locking ring	1	
	Retaining fork	2	
	Forward hose assembly	1	
	Gasket	1	
	Worm-screw clamp	1	
	R-clamp	1	
	Carriage bolt (5/16 x 1 inch)	1	
Lock nut (5/16 inch)	1		

Procedure	Description	Qty.	Use
<b>6</b>	Supply hose	1	Install the supply hose.
	Gasket	1	
	Worm-screw clamp	1	
	Hose clamp	1	
	Hose adapter	1	
<b>7</b>	Switch	1	Install the dash switch.
	10-amp fuse	1	

**Note:** Determine the left and right sides of the machine from the normal operating position.

# 1

## Parts needed for this procedure:

1	Eductor valve assembly
1	O-ring
4	Bolt (M8 –1.25 x 146 mm)
1	Bracket (Bracket may already be installed from a previous kit installation)

## Procedure

1. Move to the rear of the machine and locate the boom valve assembly on the boom valve mount bracket.
2. Loosen, but do not remove, the bolts securing the boom valve assembly to the mounting bracket (Figure 3).

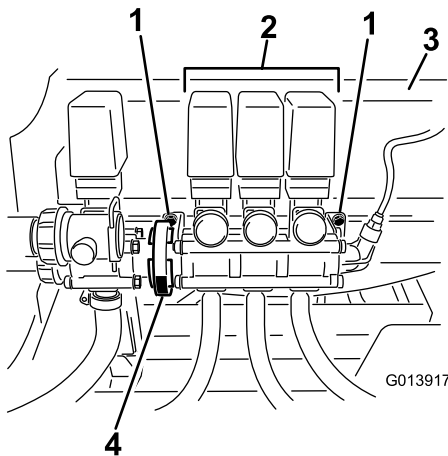

**Figure 3**

- |  |                       |
|--|-----------------------|
| 1. Bolts, securing boom valve assembly | 3. Boom mount bracket |
| 2. Boom valve assembly                 | 4. Worm clamp         |

3. Loosen the existing worm clamp to the right of the agitation valve and move the valve assemblies away from the agitation valve.

**Note:** Retain the gasket.

4. Locate the fly nut securing the agitation hose to the agitation valve body. Loosen the fly nut to allow space for the valve body fasteners to be removed (Figure 4).

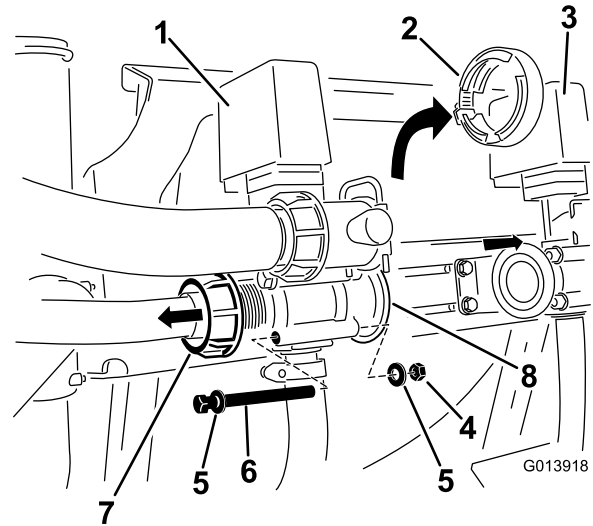

**Figure 4**

- |                        |                     |
|------------------------|---------------------|
| 1. Agitation valve     | 5. Washer, existing |
| 2. Worm clamp          | 6. Bolt, existing   |
| 3. Boom valve assembly | 7. Fly nut          |
| 4. Locknut, existing   | 8. Adapter          |

5. Remove the fasteners securing the agitation valve body to the adapter.

**Note:** Retain the locknuts and washers for use later in the installation. The long bolts can also be retained in the event of the removal of the eductor kit.

6. Remove the adapter from the valve body (Figure 4).
7. Locate the eductor valve in loose parts, and install the valve in line, to the right of the agitation valve (Figure 5).

**Note:** Make sure that the existing O-ring is present in the agitation valve before mating the male side of the eductor valve to it.

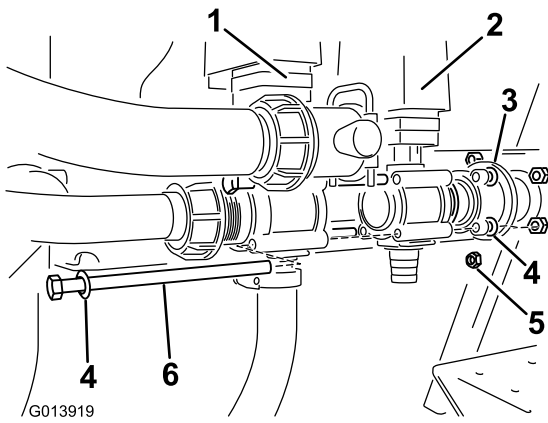

Figure 5

- |                    |                             |
|--------------------|-----------------------------|
| 1. Agitation valve | 4. Washer, existing         |
| 2. Eductor valve   | 5. Locknut, existing        |
| 3. Adapter         | 6. Bolt (M8 –1.25 x 146 mm) |

8. Install an O-ring from loose parts to the open side of the eductor valve (Figure 6).

**Note:** The O-rings must be installed properly to ensure that there are no leaks.

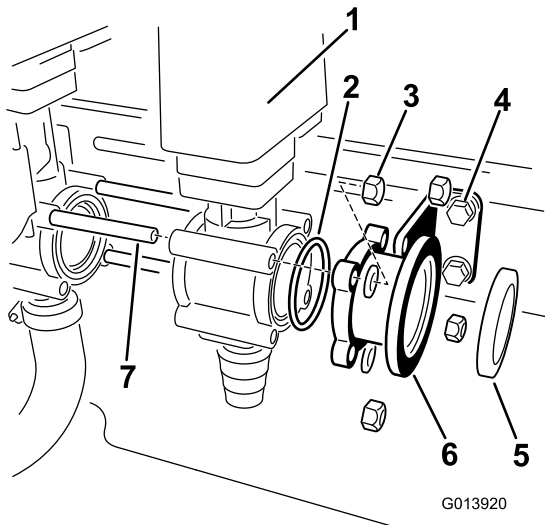

Figure 6

- |                          |                             |
|--------------------------|-----------------------------|
| 1. Eductor valve         | 5. Gasket, existing         |
| 2. O-ring                | 6. Adapter, existing        |
| 3. Locknut, existing     | 7. Bolt (M8 –1.25 x 146 mm) |
| 4. Bracket and fasteners |                             |

9. Locate the 4 long bolts (M8 -1.25 x 146 mm) in loose parts. Place a washer, removed previously, over 2 of the 4 long bolts.
10. Insert 2 long bolts, from the left side of the machine, through the mount bracket, at the top and bottom holes in the valve bodies of the agitation and the eductor valves closest to the mounting rail.
11. Use the bolts with washers to secure the valve assemblies at the open holes in the valve bodies not mounted to the bracket.

12. Insert the adapter removed previously to the open side of the eductor valve over the exposed ends of the bolts.
13. Install a bracket to the mount rail, and secure it with 2 bolts and 2 locknuts, but don't tighten them at this time.

**Note:** The bracket may already be installed from a previous kit installation.

14. Slide the bracket over the exposed threads of the bolts closest to the mount rail. Secure the bracket to the valve assembly with 2 locknuts. Don't tighten at this time.
15. Install a washer over each of the remaining bolts, and secure the assembly with 2 remaining locknuts. Don't tighten at this time.

**Note:** The bolts securing the mount bracket to the mount rail are still loose and therefore allow the bracket to move on the rail.

16. Tighten all the bolts in a crisscrossing pattern a little at a time to ensure that the O-ring seats properly and to avoid leads.

**Note:** Make sure that the bracket is free to adjust as the valves are mated (Figure 7). The maximum torque is 271-339 N-cm (24-30 in-lbs).

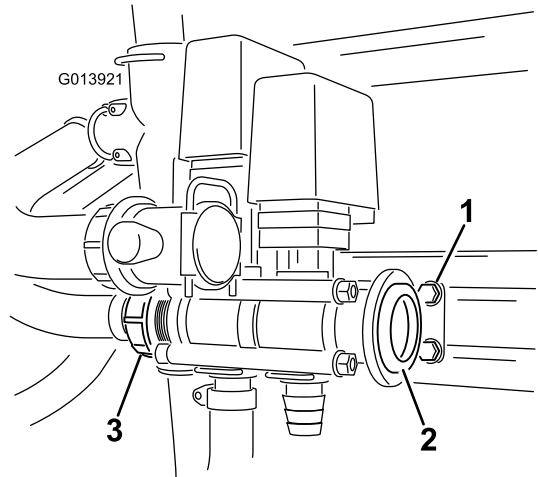
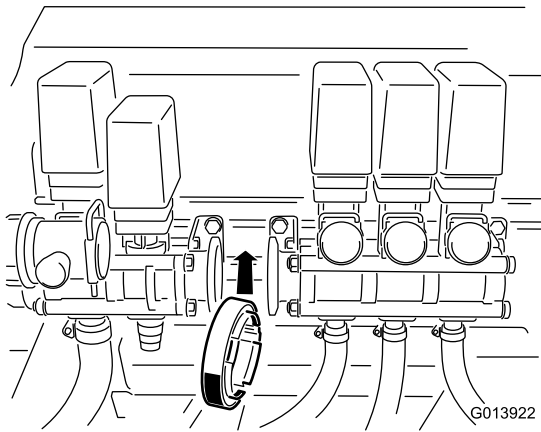

Figure 7

- |                      |            |
|----------------------|------------|
| 1. Bracket fasteners | 3. Fly nut |
| 2. Gasket            |            |

17. Install the fly nut over the threads of the agitation valve body and tighten.
18. Tighten the bracket fasteners to lock in the position on the mount rail.
19. Insert the gasket into the adapter and place the loosened worm clamp over the adapter body (Figure 7).
20. Slide the boom valve assembly back toward the new eductor valve until the 2 adapters are flush with the gasket in between them (Figure 8).



**Figure 8**

21. Move the worm clamp into position over the adapters and tighten to create the seal between them.
22. Locate the connector on the main wiring harness labeled *eductor*. Connect the eductor valve to the main harness using the labeled connector.

# 2

## Assembling the Frame

### Parts needed for this procedure:

1	Support frame assembly
1	Locknut (3/8 inch)
1	Back plate assembly
1	Cradle arm, right
1	Cradle arm, left
2	Bushing
2	Pivot pin
2	Jam nut (3/8 inch)
2	Handle
2	Bolt (3/8 x 1-1/4 inches)
2	Set screw
2	Hair pin
2	Flat washer

### Procedure

1. Remove the locknuts securing the wire lid stop to the strap. Remove the wire lid stop. Retain all parts.
2. Locate the main support frame in loose parts.
3. Install the frame over the tank strap aligning the lower hole in the frame with the exposed bolt in the side of

the tank strap and the upper hole with the upper bolt in the tank strap as shown in Figure 9.

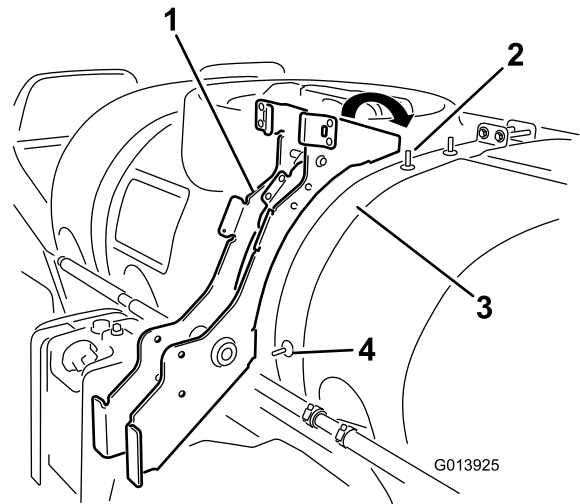

**Figure 9**

- |                                |                       |
|--------------------------------|-----------------------|
| 1. Main support frame assembly | 3. Tank strap, rear   |
| 2. Exposed bolt, top           | 4. Exposed bolt, side |

4. Install a lock nut over the lower exposed bolt passing through the frame to secure it to the tank strap (Figure 10).

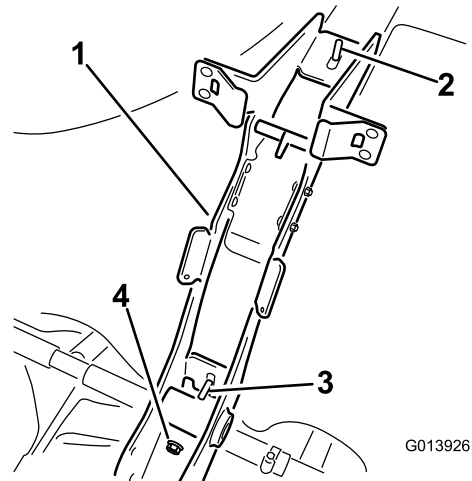

**Figure 10**

- |                                |                        |
|--------------------------------|------------------------|
| 1. Main support frame assembly | 3. Exposed bolt, side  |
| 2. Exposed bolt, top           | 4. Lock nut (3/8 inch) |

5. Install the wire tank lid stop removed previously over the protruding threads of the carriage bolts in the upper portion of the tank strap. The bow should face forward to catch the main tank lid when opened.
6. Secure the lid stop and the upper portion of the eductor frame to the tank assembly with two lock nut removed previously. Torque the fasteners to 19-24 N-m (14-18 ft-lb).
7. Assemble the eductor cradle to the frame:

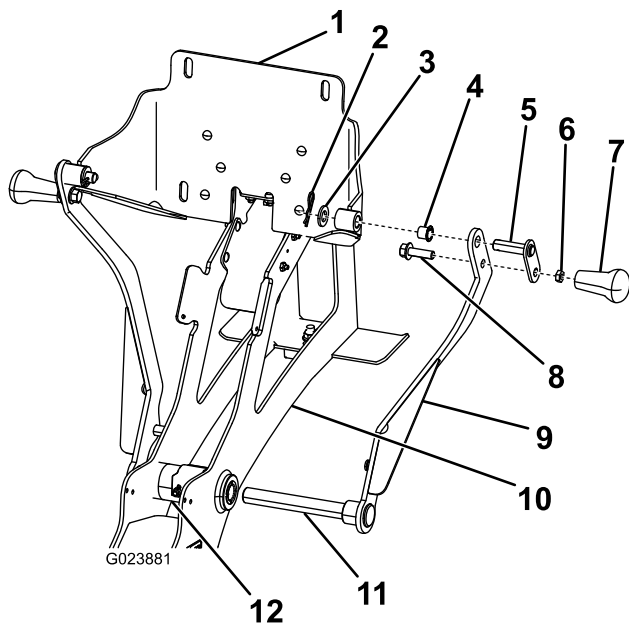

**Figure 11**

- |                        |                                 |
|------------------------|---------------------------------|
| 1. Back plate assembly | 7. Handle                       |
| 2. Hair pin            | 8. Bolt (3/8 x 1-1/4 inches)    |
| 3. Flat washer         | 9. Right cradle arm             |
| 4. Bushing             | 10. Main support frame assembly |
| 5. Pivot pin           | 11. Cradle arm axle             |
| 6. Jam nut (3/8 inch)  | 12. Pivot housing               |

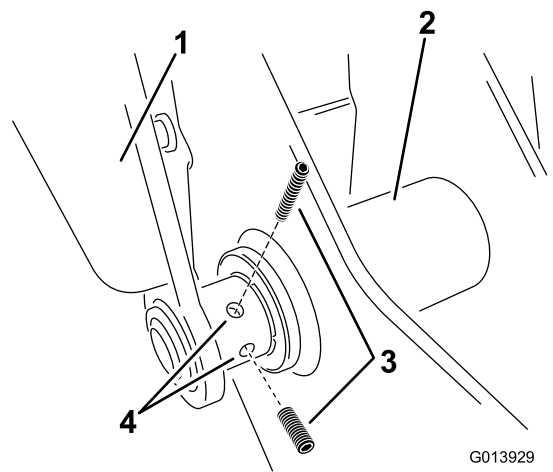

**Figure 12**

- |                     |                            |
|---------------------|----------------------------|
| 1. Cradle arm, left | 3. Set screw               |
| 2. Pivot housing    | 4. Holes in the cradle arm |

- A. Start by installing the right cradle arm to the frame. The right cradle arm is denoted by have the long axle.
- B. Insert the axle through the hinge shaft.
- C. Loosely mate the left arm to the exposed axle on the other side of the frame.
- D. Install a bushing into the outside hinge holes of the back plate assembly.
- E. Move the back plate assembly into position between the upper holes in each arm.
- F. Install a pivot pin through the upper hole in the arm and the hinge hole with the bushing in the back plate assembly.
- G. Install the handles to the lower holes in the arms. Secure with a bolt (3/8 x 1-1/4 inches) and jam nut (3/8 inch).
- H. Repeat for the opposing arm.
- I. Install a set screw to the left arm at the lower hinge point (Figure 12). Do not tighten at this time to allow for adjustment of the cradle system.

# 3

## Installing the Latching Components

### Parts needed for this procedure:

2	Spring
---	--------

### Installing the Springs

1. Install the spring in the hole in the lower end of the angled tab on the side of the frame assembly (Figure 13).

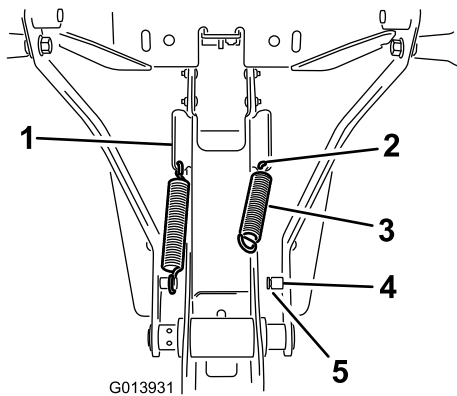

Figure 13

- |                |           |
|----------------|-----------|
| 1. Angled tab  | 4. Post   |
| 2. Hole in tab | 5. Groove |
| 3. Spring      |           |

2. Hook one end of the spring into the hole and the other end onto the spring post (Figure 13).
3. Make sure that the spring end is seated properly in the groove in the post (Figure 13).
4. Repeat steps 1 through 3 for the other side.
5. Tighten the 2 set screws in the left arm.

### Adjusting the Tongue Position

Move the cradle assembly into the upper Transport position to adjust the tongue.

1. Lift up on the handles to raise the assembly while slightly tipping it toward the tank.
2. Guide the tongue under the crossbar with the welded tab in the upper portion of the frame assembly.
3. Let the assembly pivot down, toward the tank.
4. Making sure that the plastic stops are in contact with the spring tabs, apply enough pressure against the back

plate assembly of the cradle to compress the spring tabs midway (Figure 14).

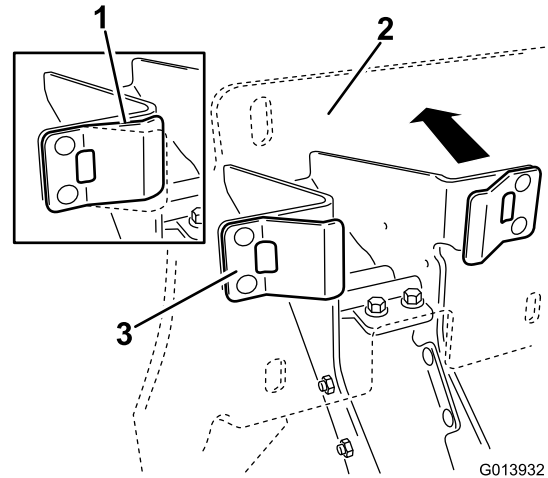

Figure 14

- |                              |               |
|------------------------------|---------------|
| 1. Spring tab under pressure | 3. Spring tab |
| 2. Back plate                |               |

5. While maintaining the pressure on the back plate, slide the tongue toward you until the lip of the tongue plate contacts the crossbar (Figure 15).

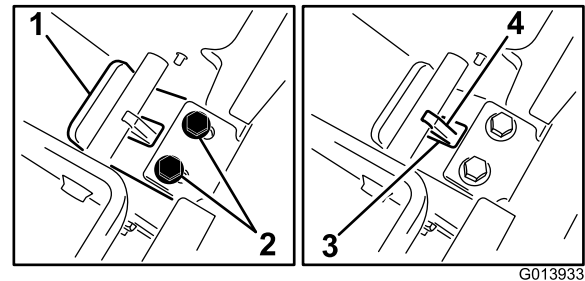

Figure 15

- |                     |                  |
|---------------------|------------------|
| 1. Tongue-plate lip | 3. Slot in plate |
| 2. Fasteners        | 4. Welded tab    |

6. Tighten the fasteners in the tongue to secure its position, then release pressure on the back plate.

**Note:** Check to see if there is any play in the cradle. It should be held snug to the frame assembly. You can repeat this procedure once the educator is installed to adjust the locked position.

# 4

## Installing the Eductor

### Parts needed for this procedure:

1	Eductor
1	Handle
2	Flange-head bolt
1	Spring clamp
2	Bolt (#10-24 x 1/2 inch)
2	Locknut (#10-24)
4	Bolt (3/8 x 1 inch)
4	Locknut (3/8 inch)
2	Flange-head nut
3	Hex-head bolt
1	Latch post
1	Latch handle
1	T-valve
1	Gasket
1	Worm-screw clamp

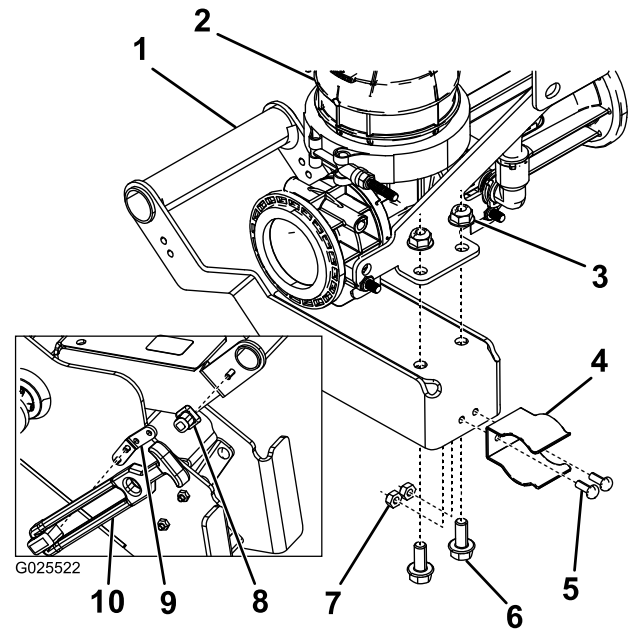

Figure 16

- |                             |                      |
|-----------------------------|----------------------|
| 1. Handle                   | 6. Flange-head bolt  |
| 2. Eductor                  | 7. Locknut (#10-24)  |
| 3. Flange-head nut          | 8. Latch post        |
| 4. Spring clamp             | 9. Extension bracket |
| 5. Bolt (#10-24 x 1/2 inch) | 10. Latch handle     |

### Procedure

1. Attach the latch post to the eductor handle using a hex-head bolt (Figure 16).

2. Attach the extension bracket to the main support frame using 2 hex-head bolts (Figure 16).
3. Connect the latch handle to the extension bracket (Figure 16).
4. Attach the handle to the eductor using 2 flange-head bolts and flange-head nuts (Figure 16).
5. Lower the cradle into the down position.
6. Align the holes in the eductor assembly mount plate with the slotted holes in the back plate of the cradle assembly (Figure 17).

**Note:** The fasteners need to be loose enough so that they can travel in the slot when the eductor is initially raised up into the transport position. This allows for further adjustment.

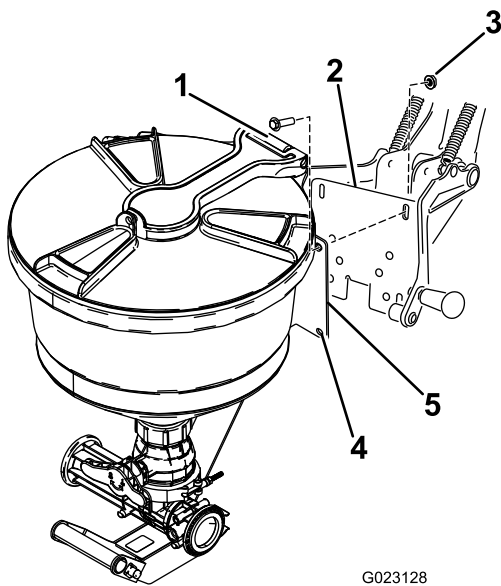

**Figure 17**

- |                        |                                |
|------------------------|--------------------------------|
| 1. Bolt (3/8 x 1 inch) | 4. Eductor assembly mount hole |
| 2. Back plate          | 5. Eductor assembly mount      |
| 3. Locknut (3/8 inch)  |                                |

- Install 4 bolts (3/8 x 1 inch) and locknuts (3/8 inch) to mount the eductor.

**Note:** Do not tighten the bolts at this time.

- To carefully raise the eductor in the cradle assembly up to the transport position, do the following:
  - Lift the lower handle to raise the eductor while slightly tipping it toward the tank.
  - Guide the tongue under the crossbar with the welded tab in the upper portion of the frame assembly.
  - Then pivot the assembly toward the tank, taking care to line up the spring clamp with the large pivot housing in the lower portion of the frame.
  - Push until the clamp snaps over the pivot housing as shown in Figure 18.

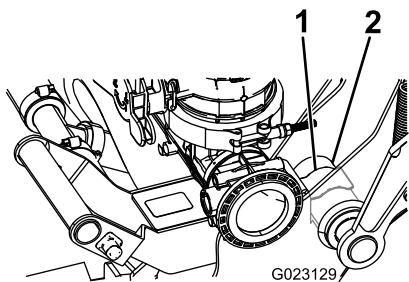

**Figure 18**

- |                 |                  |
|-----------------|------------------|
| 1. Spring clamp | 2. Pivot housing |
|-----------------|------------------|

- Check the eductor height on the cradle back plate and adjust it as necessary.

- Tighten the fasteners securing the eductor to the cradle.

**Note:** Torque the fasteners to 36-45 N-m (27-33 ft-lb).

- Tighten the 2 set screws on the left pivot arm.
- Check the overall position of the eductor assembly on the tank strap.

**Note:** The eductor should be upright, in the transport position. Loosen the lower locknut on the frame assembly securing it to the tank. Do not remove the locknut. Adjust the position as necessary and tighten the locknut. Make sure that the strap is secure to the tank.

- Connect the T-valve to the eductor assembly using a gasket and a worm-screw clamp (Figure 19).

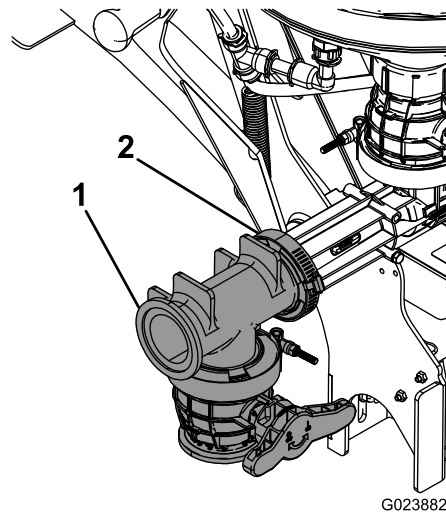

**Figure 19**

- |            |                                |
|------------|--------------------------------|
| 1. T-valve | 2. Gasket and worm-screw clamp |
|------------|--------------------------------|

# 5

## Installing the Forward Hose

### Parts needed for this procedure:

1	Bulkhead
1	O-ring
1	Locking ring
2	Retaining fork
1	Forward hose assembly
1	Gasket
1	Worm-screw clamp
1	R-clamp
1	Carriage bolt (5/16 x 1 inch)
1	Lock nut (5/16 inch)

### Drilling the Tank

1. Locate the forward location on the top of the tank as shown in Figure 20.

**Note:** Locate the drill mark in the center of the molded circle.

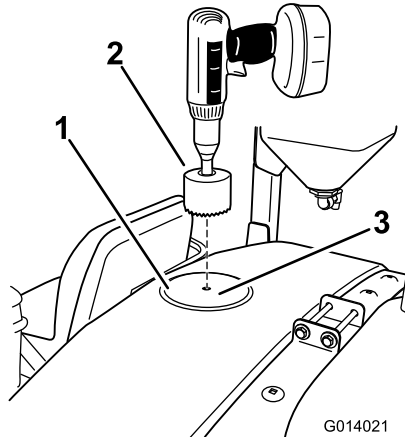

Figure 20

1. Molded circle
2. Drill with hole saw
3. Drill point, center of the molded circle

2. Use a 9 cm (3-5/8 inch) hole saw to drill a hole at the drill mark (Figure 20).

**Note:** You will need to increase the diameter slightly to accommodate the bulkhead.

3. After drilling the hole, remove any rough edges in the cut, and remove any debris that entered the main tank during the cutting process.

### Installing the Bulkhead

1. Open the main tank lid and remove the filter screen.
2. Install the bulkhead and the O-ring up from inside the tank through the previously cut opening (Figure 21).

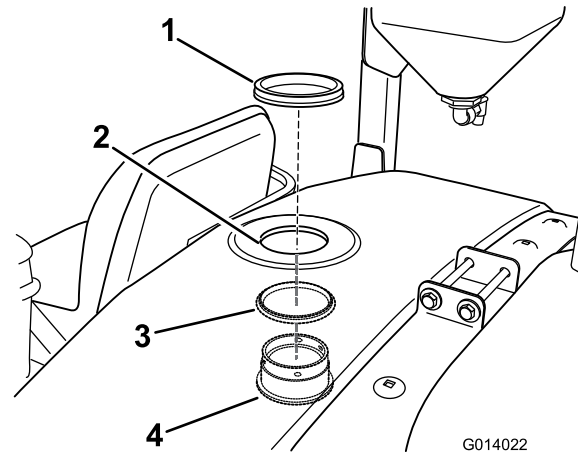

Figure 21

1. Locking ring
2. Hole, cut previously
3. O-ring
4. Bulkhead

3. Secure the bulkhead to the tank with the locking ring.

### Installing the Hose

1. Install an R-clamp over the exposed threads of the front strap's side bolt.
2. Install the hose end with the 90° fitting to the previously installed bulkhead using a retaining fork (Figure 22).

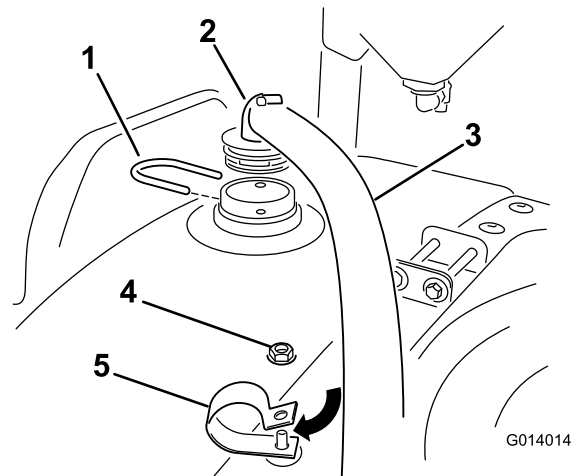

Figure 22

1. Retaining fork
2. Eductor hose assembly
3. Hose
4. Lock nut
5. R-clamp and locknut (5/16 inch)

3. Feed the open end of the hose down and through the R-clamp to the eductor.

4. Install a lock nut over the bolt in the R-clamp and finger tighten at this time (Figure 22).

**Note:** This will allow for later adjustment.

5. Attach the other end of the hose to the forward-facing opening of the eductor using a gasket and worm-screw clamp (Figure 23).

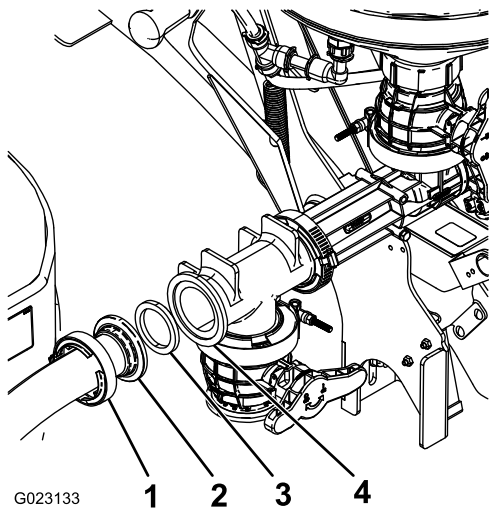

Figure 23

1. Worm-screw clamp
2. Hose
3. O-ring
4. Eductor

6. Raise and lower the eductor to ensure that the hose does not catch on anything.

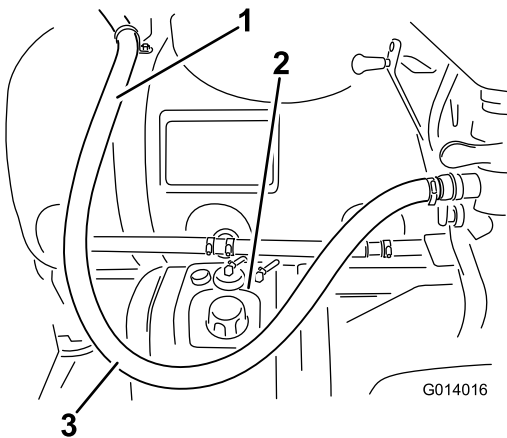

Figure 24

1. Eductor hose
2. Tank
3. Slack in the hose

# 6

## Installing the Supply Hose

### Parts needed for this procedure:

1	Supply hose
1	Gasket
1	Worm-screw clamp
1	Hose clamp
1	Hose adapter

### Procedure

1. Secure the end of the supply hose without a bulkhead to the rear opening on the eductor valve using a gasket and worm-screw clamp (Figure 25).

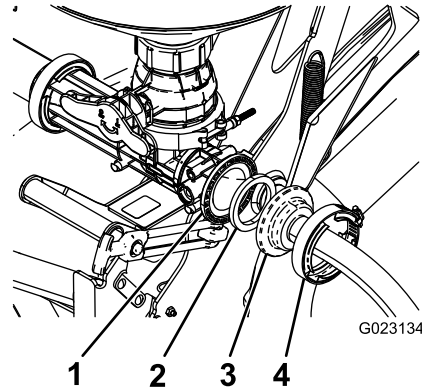
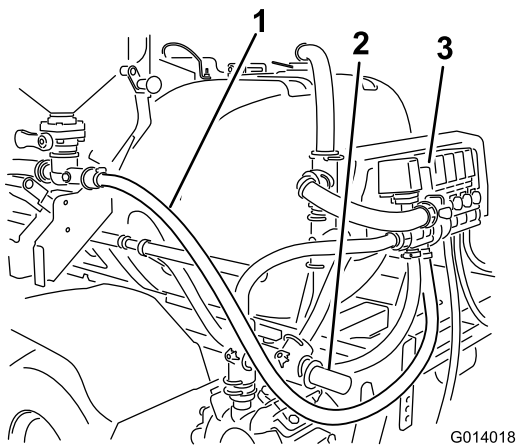

Figure 25

1. Eductor
2. O-ring
3. Hose
4. Worm-screw clamp

2. Route the open end of the supply hose rearward past the pump and turn back toward the valve assembly under the relief valve (Figure 26).

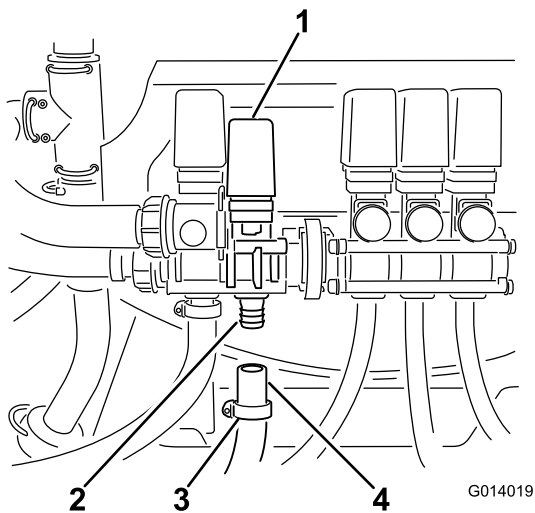

**Figure 26**

G014018

- 1. Rear hose
- 2. Relief hose
- 3. Eductor valve

- 3. Staying under the agitation hose but above the left side mount for the center boom, route the hose upward to the eductor valve assembly (Figure 26).
- 4. Slide a loosened hose clamp over the open end of the hose (Figure 27).



**Figure 27**

G014019

- 1. Eductor valve
- 2. Barb
- 3. Hose clamp
- 4. Hose end

- 5. Install the open end of the hose over the exposed barb pointing down from the eductor valve.

**Note:** Lightly lubricating the barbed end of the hose fitting with a non-petroleum based lubricant can ease the process of installation.

- 6. Slide the hose clamp over the fitting barb, and tighten the clamp to secure the fitting to the hose.

# 7

## Installing the Dash Switch

### Parts needed for this procedure:

1	Switch
1	10-amp fuse

### Procedure

- 1. Locate the plug for the eductor switch on the dash (Figure 28).

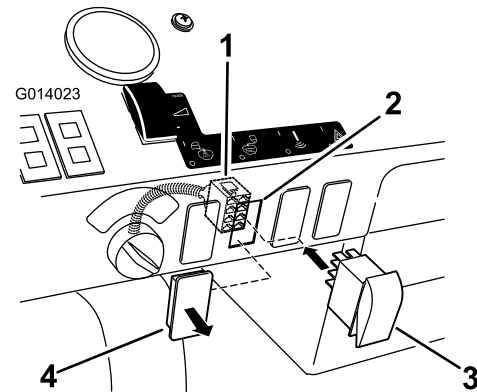

**Figure 28**

- 1. Connector for eductor, from main harness
- 2. Hole in dash
- 3. Dash switch
- 4. Plug

- 2. Remove the plug from the dash (Figure 28).
- 3. From below the dash, locate the box connector labeled *eductor* in the main harness. Remove the plastic tie securing it and route it toward the open hole in the dash.
- 4. Install the switch to the box connector, through the dash, with the LED on the switch in the upper position (Figure 28).
- 5. Push the switch into the dash to mount.
- 6. Install a 10-amp fuse into the fuse block (Figure 29).

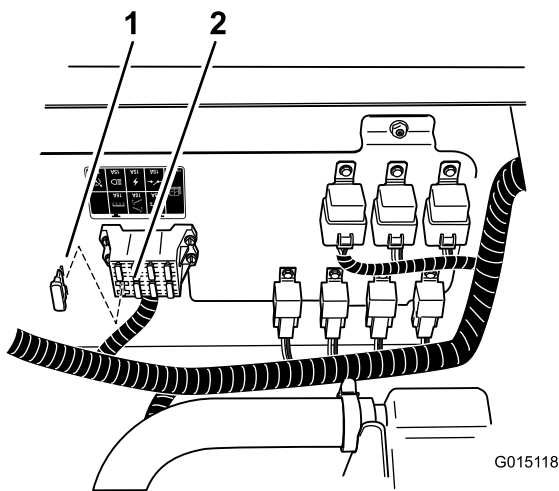

**Figure 29**

1. Fuse block                      2. 10-amp fuse

7. Adjust the agitation bypass valve as outlined in your *Operator's Manual*.

# 8

## Finishing the Installation

### Parts needed for this procedure:

1	Suction lance and hose (optional)
---	-----------------------------------

### Procedure

**Note:** The suction lance and hose are optional accessories. Contact your Authorized Toro Distributor for more information.

Retain the suction lance and hose for later use. Read and retain the remaining documentation on using the Chemical Pre-Mix Kit.

# Operation

## ⚠ CAUTION

Chemicals are hazardous and can cause personal injury.

- Read the directions on the chemical labels before handling the chemicals and follow all manufacturer recommendations and precautions.
- Keep chemicals away from your skin. Should contact occur, wash the affected area thoroughly with soap and clean water.
- Wear goggles and any other protective equipment recommended by the chemical manufacturer.

## Controls

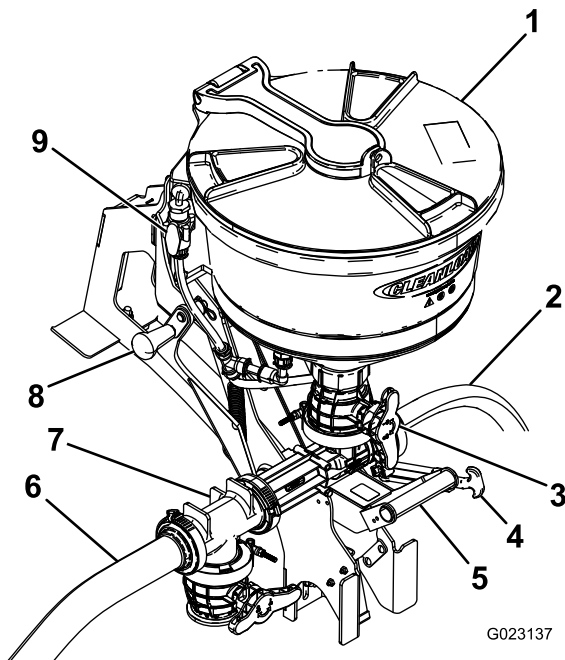

Figure 30

- |                    |                 |
|--------------------|-----------------|
| 1. Lid             | 6. Tank hose    |
| 2. Supply hose     | 7. T-valve      |
| 3. Main valve      | 8. Upper handle |
| 4. Transport strap | 9. Flush valve  |
| 5. Lower handle    |                 |

## Lid

Rotate the lid counter clockwise to open it. Close the lid completely before turning it clockwise to lock it. You must close the lid and lock it before it is raised to the Transport position.

## Handles and Transport Strap

Use the upper and lower handles to raise and lower the eductor and to lock it into the Transport position.

## Main Valve

Use the main valve to introduce chemicals from the eductor into the hose leading to the main tank.

## Bottle Rinse

The bottle rinse is located inside the eductor tank. Once the eductor switch is on, the bottle rinse has pressure and is supplied by the contents of the main tank. To use the bottle rinse, invert the chemical container over the spout and use the rim of the container to depress the rinse. Press down to actuate the spout and rinse the interior of the chemical container.

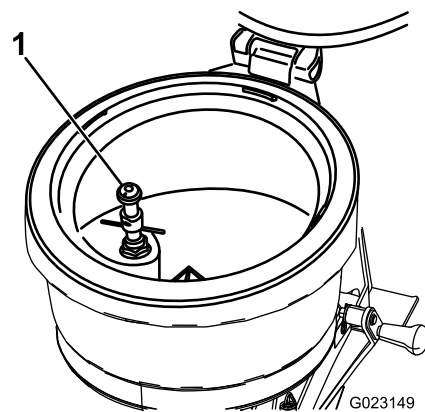

Figure 31

1. Bottle rinse

## Flush Valve

The flush valve can rinse the inside of the eductor tank. Once the eductor switch is on, the flush valve will have pressure and is supplied by the contents of the main tank. To open the valve, turn the handle 90° counterclockwise. This will introduce water to the tank. Turn the handle 90° clockwise to close the valve.

## Raising and Lowering the Eductor

### Lowering the Eductor

1. Unlatch the rubber transport strap.
2. Place a hand on the lower handle and the other hand on the upper handle.
3. Lift the eductor away from the vehicle until the spring clamp disengages.
4. Guide the eductor as it lowers to the operating position.

## Raising the Eductor

1. Lift the lower handle to raise the eductor while slightly tipping it toward the tank.
2. Guide the tongue under the crossbar with the welded tab in the upper portion of the frame assembly.
3. Pivot the assembly toward the tank, taking care to line up the spring clamp with the large pivot housing in the lower portion of the frame.
4. Push until the clamp snaps over the pivot housing.
5. Secure the handle with the transport strap.

## Protecting the Turf when Operating a Stationary Machine

**Important:** Under some conditions, heat from the engine, radiator, and muffler can potentially damage the grass when operating the sprayer in a stationary mode. Stationary modes include tank agitation, hand spraying, or using a walking boom.

Take the following precautions:

- **Avoid** stationary spraying when conditions are very hot and/or dry, as turf can be more stressed during these periods.
- **Avoid** parking the machine on the turf while stationary spraying. Park the machine on a cart path whenever possible.
- **Minimize** the amount of time that the machine is left running over any particular area of turf. Both time and temperature affect how much the grass may be damaged.
- **Set the engine speed as low as possible** to achieve the desired pressure and flow. This will minimize the heat generated and the air velocity from the cooling fan.
- **Allow heat to escape** upward from the engine compartment by raising the engine guard/seat assemblies during stationary operation rather than being forced out under the vehicle. Refer to your *Operator's Manual* for more information on raising the seat assemblies.

**Note:** Use a heat-shield blanket underneath the vehicle during stationary operation for additional heat protection. Contact your Authorized Toro Distributor to obtain a Toro heat-shield blanket kit for turf sprayers.

## Using the Eductor

The following procedure assumes the following operational states exist for the standard tank agitation: The sprayer is started and running, the pump is engaged and set to the desired pressure, and the throttle is in the mid-range position.

## Starting the Eductor

**Note:** Close the eductor hopper valve and hopper rinse ball valve(s) before starting the eductor.

1. Lower the eductor.
2. Open the lid to check for foreign objects which may hinder performance or contaminate the system.
3. Close and lock the lid by turning the cover clockwise.
4. Turn the eductor valve to open the eductor circuit.
5. Open the hopper valve (red handle) located on the bottom of the hopper.
6. Unlock and open the lid slowly by turning the cover counterclockwise.

## Loading Liquid or Powdered Chemical into the Hopper

1. Pour the required amount of chemical into the hopper.

**Note:** Avoid splashing liquids or powdered chemicals outside of the hopper.

2. Rinse the empty chemical containers if applicable.
3. Place the container opening over the container rinse valve and press down.

**Note:** This will activate the rinse valve and rinse the container.

4. Close and lock the lid by turning the cover clockwise.
5. Open the rinse ball valve and turn it on for 20 seconds to rinse the hopper.

**Note:** Close the ball valve and return the locking band to the locked position.

6. Open the lid and inspect for chemical residue.
7. Repeat step 4 as necessary.
8. Close the hopper valve.

## Loading Chemicals with the Optional Suction Lance

**Note:** Lance suction depends upon eductor pressure and flow. For best results, use pressure up to 10 bar (150 psi) maximum.

1. Insert the suction lance body into the eductor until the O-ring seals on the hopper drain.

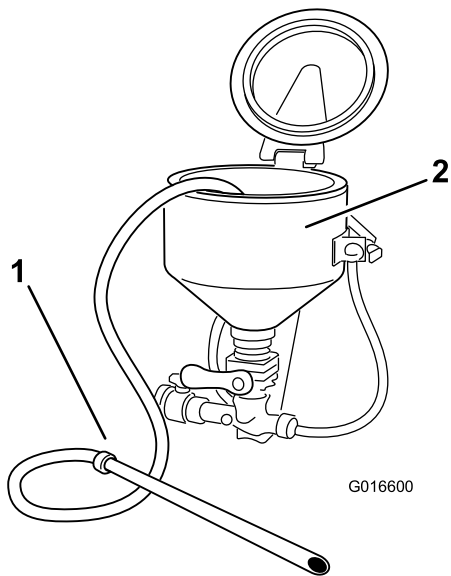

**Figure 32**

1. Suction lance                      2. Eductor
- 

2. Use the free end of the lance to pierce the bag or container to vacuum powdered or liquid chemical.
3. Place the lance end into a clean container of water to rinse the lance assembly.
4. Remove the lance body from eductor and drain any remaining fluid into the hopper.
5. Close the hopper valve (red handle).

## Shutting down the Eductor

1. Close all the valves.  
**Note:** Close the hopper valve first.
2. Remove all chemical residue.
3. Close and lock the hopper lid by turning the cover clockwise.
4. Return the agitation valve to the fully open position.
5. Close the eductor valve.
6. Return the eductor to the transport position, and lock it with the transport strap.

# Troubleshooting

Problem	Possible Cause	Corrective Action
The education rate is low.	<ol style="list-style-type: none"> <li>1. There is a lack of flow and pressure to the eductor system.</li> <li>2. The outlet/Inlet hose is obstructed.</li> <li>3. Fittings with elbows or other flow-restrictions are in the eductor outlet.</li> </ol>	<ol style="list-style-type: none"> <li>1. Increase the pump speed. Turn the agitation throttling toward the closed position.</li> <li>2. Disassemble and remove any obstructions.</li> <li>3. Use only sweeping turns with flexible hoses.</li> </ol>
There is no rinsing or flushing action.	<ol style="list-style-type: none"> <li>1. The bottle rinse nozzle is plugged or clogged.</li> <li>2. The flush tee is plugged or clogged.</li> </ol>	<ol style="list-style-type: none"> <li>1. Disassemble the rotary portion of the nozzle from the lower valve assembly and back flush until the nozzle ports are clear of debris.</li> <li>2. Disassemble the flush tee and clean until the nozzle ports are clear of debris.</li> </ol>
There are leaks at the fittings.	<ol style="list-style-type: none"> <li>1. The fittings are damaged.</li> <li>2. The thread sealant is worn.</li> </ol>	<ol style="list-style-type: none"> <li>1. Check for cracks in the fitting. Replace the fitting if necessary.</li> <li>2. Disassemble and seal the joint with joint seal compound if a leak occurs on the threads.</li> </ol>

**Notes:**



# The Toro Total Coverage Guarantee

## A Limited Warranty

### Conditions and Products Covered

The Toro Company and its affiliate, Toro Warranty Company, pursuant to an agreement between them, jointly warrant your Toro Commercial product ("Product") to be free from defects in materials or workmanship for two years or 1500 operational hours\*, whichever occurs first. This warranty is applicable to all products with the exception of Aerators (refer to separate warranty statements for these products). Where a warrantable condition exists, we will repair the Product at no cost to you including diagnostics, labor, parts, and transportation. This warranty begins on the date the Product is delivered to the original retail purchaser.

\* Product equipped with an hour meter.

### Instructions for Obtaining Warranty Service

You are responsible for notifying the Commercial Products Distributor or Authorized Commercial Products Dealer from whom you purchased the Product as soon as you believe a warrantable condition exists. If you need help locating a Commercial Products Distributor or Authorized Dealer, or if you have questions regarding your warranty rights or responsibilities, you may contact us at:

Toro Commercial Products Service Department  
Toro Warranty Company  
8111 Lyndale Avenue South  
Bloomington, MN 55420-1196  
952-888-8801 or 800-952-2740  
E-mail: commercial.warranty@toro.com

### Owner Responsibilities

As the Product owner, you are responsible for required maintenance and adjustments stated in your *Operator's Manual*. Failure to perform required maintenance and adjustments can be grounds for disallowing a warranty claim.

### Items and Conditions Not Covered

Not all product failures or malfunctions that occur during the warranty period are defects in materials or workmanship. This warranty does not cover the following:

- Product failures which result from the use of non-Toro replacement parts, or from installation and use of add-on, or modified non-Toro branded accessories and products. A separate warranty may be provided by the manufacturer of these items.
- Product failures which result from failure to perform recommended maintenance and/or adjustments. Failure to properly maintain your Toro product per the Recommended Maintenance listed in the *Operator's Manual* can result in claims for warranty being denied.
- Product failures which result from operating the Product in an abusive, negligent, or reckless manner.
- Parts subject to consumption through use unless found to be defective. Examples of parts which are consumed, or used up, during normal Product operation include, but are not limited to, brake pads and linings, clutch linings, blades, reels, rollers and bearings (sealed or greasable), bed knives, spark plugs, castor wheels and bearings, tires, filters, belts, and certain sprayer components such as diaphragms, nozzles, and check valves, etc.
- Failures caused by outside influence. Conditions considered to be outside influence include, but are not limited to, weather, storage practices, contamination, use of unapproved fuels, coolants, lubricants, additives, fertilizers, water, or chemicals, etc.
- Failure or performance issues due to the use of fuels (e.g. gasoline, diesel, or biodiesel) that do not conform to their respective industry standards.

### Countries Other than the United States or Canada

Customers who have purchased Toro products exported from the United States or Canada should contact their Toro Distributor (Dealer) to obtain guarantee policies for your country, province, or state. If for any reason you are dissatisfied with your Distributor's service or have difficulty obtaining guarantee information, contact the Toro importer.

- Normal noise, vibration, wear and tear, and deterioration.
- Normal "wear and tear" includes, but is not limited to, damage to seats due to wear or abrasion, worn painted surfaces, scratched decals or windows, etc.

### Parts

Parts scheduled for replacement as required maintenance are warranted for the period of time up to the scheduled replacement time for that part. Parts replaced under this warranty are covered for the duration of the original product warranty and become the property of Toro. Toro will make the final decision whether to repair any existing part or assembly or replace it. Toro may use remanufactured parts for warranty repairs.

### Deep Cycle and Lithium-Ion Battery Warranty:

Deep cycle and Lithium-Ion batteries have a specified total number of kilowatt-hours they can deliver during their lifetime. Operating, recharging, and maintenance techniques can extend or reduce total battery life. As the batteries in this product are consumed, the amount of useful work between charging intervals will slowly decrease until the battery is completely worn out. Replacement of worn out batteries, due to normal consumption, is the responsibility of the product owner. Battery replacement may be required during the normal product warranty period at owner's expense. Note: (Lithium-Ion battery only): A Lithium-Ion battery has a part only prorated warranty beginning year 3 through year 5 based on the time in service and kilowatt hours used. Refer to the *Operator's Manual* for additional information.

### Maintenance is at Owner's Expense

Engine tune-up, lubrication, cleaning and polishing, replacement of filters, coolant, and completing recommended maintenance are some of the normal services Toro products require that are at the owner's expense.

### General Conditions

Repair by an Authorized Toro Distributor or Dealer is your sole remedy under this warranty.

**Neither The Toro Company nor Toro Warranty Company is liable for indirect, incidental or consequential damages in connection with the use of the Toro Products covered by this warranty, including any cost or expense of providing substitute equipment or service during reasonable periods of malfunction or non-use pending completion of repairs under this warranty. Except for the Emissions warranty referenced below, if applicable, there is no other express warranty. All implied warranties of merchantability and fitness for use are limited to the duration of this express warranty.**

Some states do not allow exclusions of incidental or consequential damages, or limitations on how long an implied warranty lasts, so the above exclusions and limitations may not apply to you. This warranty gives you specific legal rights, and you may also have other rights which vary from state to state.

### Note regarding engine warranty:

The Emissions Control System on your Product may be covered by a separate warranty meeting requirements established by the U.S. Environmental Protection Agency (EPA) and/or the California Air Resources Board (CARB). The hour limitations set forth above do not apply to the Emissions Control System Warranty. Refer to the Engine Emission Control Warranty Statement supplied with your product or contained in the engine manufacturer's documentation for details