



MODEL NO. 30450 - 30001 & UP  
 MODEL NO. 30455 - 30001 & UP  
 MODEL NO. 30401 - 30001 & UP

## OPERATOR'S MANUAL

# GROUNDMASTER<sup>®</sup> 455 D

TRACTION UNITS & CUTTING UNIT

To understand this product, and for safety and optimum performance, read this manual before starting the engine. Pay special attention to SAFETY INSTRUCTIONS highlighted by this symbol.



It means CAUTION, WARNING or DANGER - personal safety instruction. Failure to comply with the instruction may result in personal injury.



The GROUNDMASTER 455-D conforms to the American National Standards Institute's safety standards for riding mowers when standard rear weight ballast is installed: thus, TORO proudly displays the ANSI safety seal.



# FOREWORD

This operator's manual has instructions on safety, proper set-up and operation, adjustments and maintenance. Therefore, anyone involved with the product, including the operator, should read and understand this manual. Major sections are:

- Safety Instructions
- Before Operating
- Operating Instructions
- Maintenance
- Schematics
- Seasonal Storage

This manual emphasizes safety, mechanical and general product information. **DANGER, WARNING** and **CAUTION** identify safety messages. Whenever the triangular safety alert symbol appears, understand the safety message that follows. For complete safety instructions, read pages 4 – 5. **IMPORTANT** highlights special mechanical information and **NOTE** emphasizes general product information worthy of special attention.

## OPTIONAL SPARK ARRESTER

In some places a spark arrester muffler must be used because of local, state or federal regulations. The spark arrester available from your local Toro Distributor is approved by the United States Department of Agriculture and the United States Forest Service. If a spark arrester muffler is required, order the following part from your Authorized Toro Distributor:

(1) 77-3990 Spark Arrester Muffler

When the mower is used or operated on any California forest, brush or grass covered land, a properly operating spark arrester must be attached to the muffler. The operator is violating state law, Section 442 Public Resources Code if a spark arrester is not used.

Whenever you have questions or need service, contact your local authorized Toro Distributor. In addition to having a complete line of accessories and professional turf care service technicians, the distributor has a complete line of genuine TORO replacement parts to keep your machine operating properly. Keep your TORO all TORO. Buy genuine TORO parts and accessories.

## IDENTIFICATION AND ORDERING

### MODEL AND SERIAL NUMBER

The model and serial number for the traction unit is on a plate that is mounted on the left front frame member. The model and serial number for the cutting unit is on a plate that is mounted on top front of the center cutting unit. Use model and serial number in all correspondence and when ordering parts.

To order replacement parts from an authorized TORO Distributor, supply the following information:

1. Model and serial numbers of the machine.
2. Part number, description and quantity of parts desired.

**Note:** Do not order by reference number if a parts catalog is being used; use the part number.

# TABLE OF CONTENTS

<b>PRODUCT IDENTIFICATION</b> .....	2	Engine Fan Belt .....	25
<b>TABLE OF CONTENTS</b> .....	3	<b>HYDRAULIC MAINTENANCE</b> .....	25–27
<b>SAFETY INSTRUCTIONS</b> .....	4–5	Changing Hydraulic Oil .....	25
<b>SAFETY AND INSTRUCTION DECALS</b> .....	6–8	Replacing Hydraulic Filter .....	26
<b>SPECIFICATIONS</b> .....	9–10	Checking Hydraulic Lines and Hoses .....	26
<b>LOOSE PARTS CHART</b> .....	10	Hydraulic System Test Ports .....	26
<b>BEFORE OPERATING</b> .....	10–14	Adjusting Traction Drive for Neutral .....	27
Check Engine Oil .....	10	<b>HYDRAULIC SCHEMATICS</b> .....	28
Check Cooling System .....	11	<b>AXLE MAINTENANCE</b> .....	29
Fill Fuel Tank .....	11	Changing Front Axle Lubricant .....	29
Check Hydraulic Circuit Oil .....	11	Changing Rear Axle Lubricant (Model 30455) .....	29
Check Front Axle Oil Level .....	12	Rear Wheel Toe–In .....	29
Check Rear Axle Lubricant (Model 30455 only) .....	12	<b>BRAKE MAINTENANCE</b> .....	30
Check Tire Pressure .....	13	Adjusting Service Brakes .....	30
Check Torque of Wheel Nuts .....	13	<b>P.T.O. MAINTENANCE</b> .....	30
Check Lubricant in Gear Box .....	13	Adjusting P.T.O. Belt .....	30
Adjusting Height–of–Cut .....	13	Adjusting Clutch .....	30
Safety Doors .....	14	<b>ELECTRICAL MAINTENANCE</b> .....	31
<b>KNOW YOUR CONTROLS</b> .....	15–16	Battery Care .....	31
<b>OPERATING INSTRUCTIONS</b> .....	16–18	Fuses .....	31
Starting and Stopping .....	16	<b>ELECTRICAL SCHEMATIC</b> .....	31
Priming / Bleeding Fuel System .....	16	<b>CUTTING UNIT MAINTENANCE</b> .....	32
Checking Interlock System .....	17	General Maintenance .....	32
Operating Characteristics .....	17	Separating Cutting Unit From Traction Unit .....	32
Operating Tips .....	18	Mounting Cutting Unit to Traction Unit .....	33
<b>SERVICE INTERVAL CHARTS</b> .....	19	Safety Door Adjustment .....	33
<b>LUBRICATION</b> .....	19–21	Blade Adjustment .....	34
Greasing .....	19–21	Adjusting Belt Tension .....	34
<b>AIR CLEANER MAINTENANCE</b> .....	22–23	Replacing Drive Belts .....	35
General Maintenance Practices .....	22	Adjusting Deck Clutch .....	36
Servicing Dust Cup and Baffle .....	22	Servicing Front Bushings in Castor Arms .....	36
Servicing Air Cleaner Filter .....	22	Servicing Castor Wheels and Bearings .....	36
Inspecting Filter Element .....	23	Removing Cutter Blade .....	37
<b>ENGINE MAINTENANCE</b> .....	23–25	Inspecting and Sharpening Blade .....	37
Engine and Oil Filter .....	23	<b>PREPARATION FOR SEASONAL STORAGE</b> ...	38
Fuel System .....	23	<b>MAINTENANCE CHART</b> .....	39
Engine Cooling System .....	24	<b>THE TORO PROMISE</b> .....	Back Cover



# SAFETY INSTRUCTIONS

The **GROUNDMASTER 455-D** was tested and certified by **TORO** for compliance with the **B71.4-1990** specifications of the **American National Standards Institute**. Although hazard control and accident prevention partially are dependent upon the **design and configuration** of the machine, these factors are also dependent upon the awareness, concern, and proper training of the personnel involved in the operation, transport, maintenance, and storage of the machine. Improper use or maintenance of the machine can result in injury or death. To reduce the potential for injury or death, comply with the following safety instructions.

**WARNING:** Engine exhaust contains carbon monoxide which is an odorless, deadly poison. Carbon monoxide is also known to the State of California to cause birth defects. Do not run engine indoors or in an enclosed area.

## BEFORE OPERATING

1. Read and understand the contents of this manual before starting and operating the machine. Become familiar with the controls and know how to stop the machine and engine quickly. A free replacement manual is available by sending the complete model and serial number to:

The Toro Company  
8111 Lyndale Avenue South  
Minneapolis, Minnesota 55420.

2. Never allow children to operate the machine. Do not allow adults to operate machine without proper instruction. Only trained operators who have read this manual should operate this machine.

3. Never operate the machine when under the influence of drugs or alcohol.

4. Keep all shields, safety devices and decals in place. If a shield, safety device or decal is defective, illegible or damaged, repair or replace it before operating the machine. Also tighten any loose nuts, bolts or screws to ensure machine is in safe operating condition.

5. Always wear substantial shoes. Do not operate machine while wearing sandals, tennis shoes, sneakers or when barefoot. Do not wear loose fitting clothing that could get caught in moving parts and possibly cause personal injury. Wearing safety glasses, safety shoes, long pants and a helmet is advisable and required by some local ordinances and insurance regulations.

6. Assure interlock switches are adjusted correctly so engine cannot be started unless traction pedal is **NEUTRAL** and cutting unit is **DISENGAGED**.

7. Remove all debris or other objects that might be picked up and thrown by the blades or fast moving

components from other attached implements. Keep all bystanders away from operating area.

8. Since diesel fuel is highly flammable, handle it carefully:

- A. Use an approved fuel container.
- B. Do not remove fuel tank cap while engine is hot or running.
- C. Do not smoke while handling fuel.
- D. Fill fuel tank outdoors and only to within an inch from the top of the tank, not the filler neck. Do not overfill.
- E. Wipe up any spilled fuel.

## WHILE OPERATING

9. Sit on the seat when starting and operating the machine.

10. Before starting the engine:

- A. Engage the parking brake.
- B. Make sure traction pedal is in **NEUTRAL** and cutting decks are **DISENGAGED**. Move axle shift to **HI** or **LO** position.
- C. After engine is started, release parking brake and keep foot off traction pedal. Machine must not move. If movement is evident, the neutral return mechanism is adjusted incorrectly; therefore, shut engine off and adjust until machine does not move when traction pedal is released. Refer to **Adjusting Traction Drive for Neutral**, page 27.

11. Seating capacity is one person. Therefore, never carry passengers.

12. Do not run engine in a confined area without adequate ventilation. Exhaust fumes are hazardous and could possibly be deadly.

13. Check interlock switches daily for proper operation. Do not rely entirely on safety switches - use common sense. If a switch fails, replace it before operating the machine. The interlock system is for your protection, so do not bypass it. Replace all interlock switches every two years.

14. Using the machine demands attention and to prevent loss of control:

- A. Operate only in daylight or when there is good artificial light.
- B. Drive slowly. Avoid sudden stops and starts.
- C. Watch for holes or other hidden hazards.
- D. Look behind machine before backing up.
- E. Do not drive close to a sand trap, ditch, creek or other hazard.
- F. Reduce speed when making sharp turns and turning on a hillside.



## SAFETY INSTRUCTIONS

15. Traverse slopes carefully. Do not start or stop suddenly when traveling uphill or downhill. Never shift axle when moving. Machine must be on a flat surface and / or brakes must be engaged to prevent freewheeling.
  16. Operator must be skilled and trained in how to drive on hillsides. Failure to use caution on slopes or hills may cause loss of control and vehicle to tip or roll possibly resulting in personal injury or death.
  17. When operating 4 wheel drive machine, always use the seat belt and ROPS together and have seat pivot retaining pin installed.
  18. If engine stalls or loses headway and cannot make it to the top of a slope, do not turn machine around. Always back slowly straight down the slope.
  19. Raise cutting decks and latch securely in transport position before driving from one work area to another.
  20. **DON'T TAKE AN INJURY RISK!** When a person or pet appears unexpectedly in or near the mowing area, **STOP MOWING**. Careless operation, combined with terrain angles, ricochets, or improperly positioned guards can lead to thrown object injuries. Do not resume mowing until area is cleared.
  21. Do not touch engine, muffler or exhaust pipe while engine is running or soon after it is stopped. These areas could be hot enough to cause burns.
  22. If cutting deck strikes a solid object or vibrates abnormally, stop immediately, turn engine off, set parking brake and wait for all motion to stop. Inspect for damage. If damaged, repair or replace any components before operating.
  23. Before getting off the seat:
    - A. Set parking brake.
    - B. Move traction pedal to neutral and axle shift to HI or LO position.
    - C. Disengage cutting decks and wait for blades to stop.
    - D. Stop engine and remove key from switch.
    - E. Do not park on slopes unless wheels are chocked or blocked.
  24. Use only a rigid tow bar if it becomes necessary to tow machine. Use trailer for normal transport.
- ### MAINTENANCE
25. Before servicing or making adjustments, stop engine and remove key from the switch.
  26. Make sure machine is in safe operating condition by keeping all nuts, bolts and screws tight.
  27. Make sure all hydraulic line connectors are tight, and all hydraulic hoses and lines are in good condition before applying pressure to the system.
  28. Keep body and hands away from pin hole leaks or nozzles that eject high pressure hydraulic fluid. Use cardboard or paper to find hydraulic leaks. Hydraulic fluid escaping under pressure can penetrate skin and cause injury. Fluid accidentally injected into the skin must be surgically removed within a few hours by a doctor familiar with this form of injury or gangrene may result.
  29. Before disconnecting or performing any work on the hydraulic system, all pressure in system must be relieved by lowering cutting units to the ground and stopping engine.
  30. If major repairs are ever needed or assistance is desired, contact an Authorized Toro Distributor.
  31. To reduce potential fire hazard, keep engine area free of excessive grease, grass, leaves and dirt. Clean protective screen on back of machine frequently.
  32. If engine must be running to perform maintenance or an adjustment, keep hands, feet, clothing and other parts of the body away from cutting units and other moving parts. Keep all bystanders away.
  33. Do not overspeed the engine by changing governor setting. To assure safety and accuracy, have an Authorized Toro Distributor check maximum engine speed.
  34. Shut engine off before checking or adding oil to the crankcase.
  35. Disconnect battery before servicing the machine. If battery voltage is required for troubleshooting or test procedures, temporarily connect the battery.
  36. At the time of manufacture, the machine conformed to the safety standards for riding mower. Ballast weight, mounted to rear of traction unit, is required for machine to conform to safety standard. **DO NOT** remove ballast weight at any time. To assure optimum performance and continued safety certification of the machine, use genuine Toro replacement parts and accessories. Replacement parts and accessories made by other manufacturers may result in non-conformance with the safety standards, and the warranty may be voided.



# SAFETY AND INSTRUCTION DECALS

The following safety and instruction decals are affixed to the traction unit. If any decal becomes illegible or damaged, install a new decal. Part numbers are listed below and in your Parts Catalog.

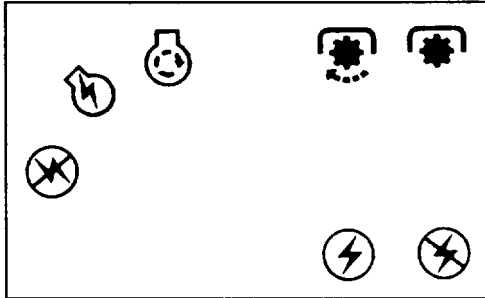

ON RIGHT HAND CONSOLE  
( Part No. 84-1450 )  
Key Switch - Off, On & Start;  
Cutting Unit Engagement Switch  
- Stop & Start

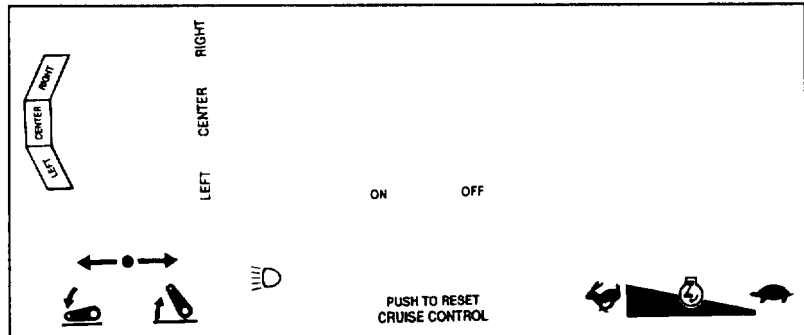

ON RIGHT HAND CONSOLE  
( Part No. 86-5410 )  
Cutting Deck Lift Controls - Raise & Lower  
Throttle Control - Increase or Decrease Speed  
Light Switch - Optional  
Cruise Control - Optional



ON FAN SHROUD  
( Part No. 76-8750 )  
Keep Hands Away From Rotating Fan



ON ACCESS PANEL & FUEL TANK SUPPORT (MODEL 30455 ONLY), ALSO ON CUTTING DECK GEAR BOX SUPPORT ( Part No. 70-2560 )  
Gear Lube Requirements

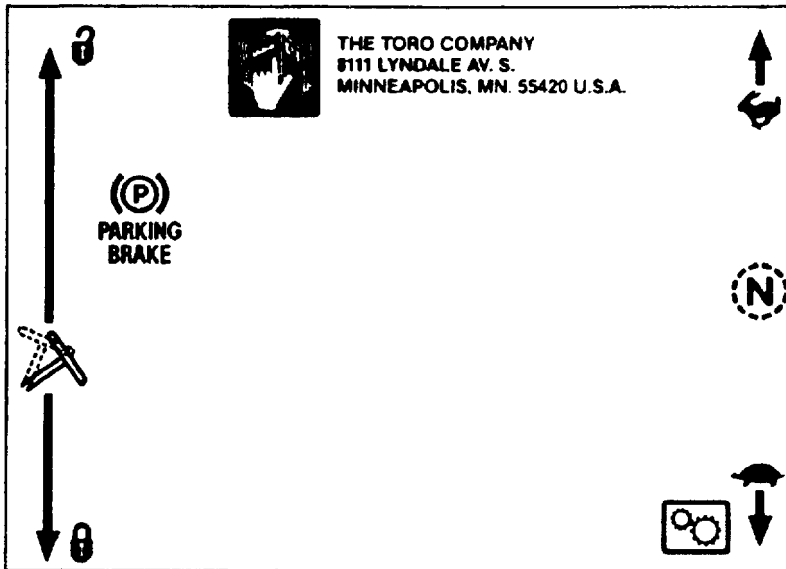

ON TOWER  
(Part No. 76-8720)  
Steering Wheel Tilt - Lock & Unlock  
Parking Brake Latch - Engage  
Ground Speed Selector - Hi, N & LO

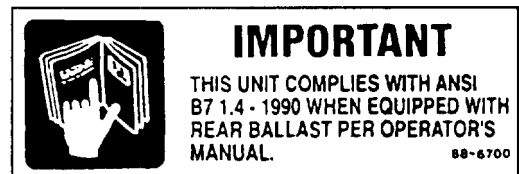

ON LEFT FRONT FRAME MEMBER  
( Part No. 88-6700 )  
ANSI Requirements

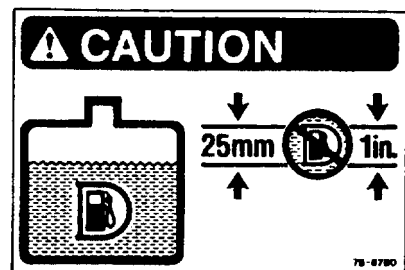

ON FUEL SPLASH GUARD  
(Part No. 76-8780)  
Fill Fuel Tank To No More Than  
than One Inch Below Bottom Of Filler Neck  
With No. 2 Diesel Fuel.



# SAFETY AND INSTRUCTION DECALS

**GM 455-D 2WD  
QUICK REFERENCE AID**

**CHECK/SERVICE**

- ENGINE OIL LEVEL/FILL
- HYDRAULIC OIL LEVEL/FILL
- FRONT AXLE OIL LEVEL/FILL
- FAN BELT
- COOLANT LEVEL/FILL
- FUEL-DIESEL ONLY
- GREASE POINTS (19)
- RADIATOR SCREEN
- AIR CLEANER
- WATER SEPARATOR/FUEL FILTER
- BATTERY
- TIRE PRESSURE (1-1.5 BAR/15-20 PSI)

**FLUID SPECIFICATIONS/CHANGE INTERVALS**

*See operator's manual for initial changes.	FLUID TYPE	CAPACITY		CHANGE INTERVAL		FILTER PART NO.
		L	USA	FLUID	FILTER	
ENGINE OIL	SAE 10W-30 CD	5	5.3QT	50 HRS	100 HRS	74-7970 (C)
HYD. CIRCUIT OIL	Mobil DTE 26	24.5	6.50	500 HRS	500 HRS	86-3010 (E)
AXLE OIL	SAE 80-90 E.P.	-	-	750 HRS	-	-
FUEL FILTER	-	-	-	400 HRS	78-5220 (C)	-
AIR CLEANER	Clean @ 50 hrs.	-	-	250 HRS	27-7110 (D)	-
FUEL	>32°F 0°C	NO. 2-D	53	14 GAL.	-	-
	<32°F 0°C	NO. 1-D	-	-	-	-
COOLANT	50/50 Peugeot recommended anti-freeze	13.25	3.5 GAL.	-	-	Drain and flush, 2 yrs.

86-5930

**ON RIGHT HAND CONSOLE FRONT**  
(Part No. 86-5930, Model 30450)  
(Part No. 86-5920, Model 30455)  
Quick Reference Aid

**⚠ DANGER**

TO AVOID SERIOUS INJURY OR DEATH COMPLY WITH THE FOLLOWING SAFETY INSTRUCTIONS. READ AND UNDERSTAND OPERATOR'S MANUAL BEFORE OPERATING THIS MACHINE.

LOS OPERADORES DEBEN ESTAR MUY BIEN CAPACITADOS EN UNA OPERACION SEGURA.

USE EXTREME CAUTION ON HILLS AND SLOPES.

- SEAT BELT SHOULD ALWAYS BE USED WHEN OPERATING WITH ROLL-OVER PROTECTION STRUCTURE. SEAT PIVOT RETAINING PIN MUST BE INSTALLED.
- GO SLOW AND AVOID SHARP TURNS ON SLOPES TO AVOID ROLLOVER.
- DECK MUST BE LOWERED WHEN GOING DOWN SLOPES FOR STEERING CONTROL.
- OPERATOR MUST BE SKILLED AND TRAINED IN SLOPE OPERATION.
- CARRY NO RIDERS. KEEP PEOPLE AND PETS A SAFE DISTANCE FROM MACHINE.
- LIFT AND SECURE DECK BEFORE TRANSPORTING.
- KEEP ALL GUARDS IN PLACE.
- BEFORE LEAVING OPERATOR'S POSITION:
  - MOVE TRACTION PEDAL TO NEUTRAL.
  - DISENGAGE DECK DRIVE.
  - SET PARKING BRAKE.
  - SHUT OFF ENGINE - REMOVE KEY.
- STOP ENGINE BEFORE ADDING FUEL OR SERVICING MACHINE.
- CHECK PERFORMANCE OF ALL INTERLOCK SWITCHES DAILY.
- BEFORE TOWING SEE OPERATOR'S MANUAL FOR INSTRUCTIONS.

86-1471

**ON REAR OF TOWER**  
(Part No. 84-1470)\*  
Operating & Safety Instructions



**ON AIR CLEANER**  
(Part No. 76-8770)  
Do Not Use Starting Fluid



**ON WING DECKS (2)**  
(Part No. 66-1340)  
Keep Hands & Feet Away From  
Rotating Blades

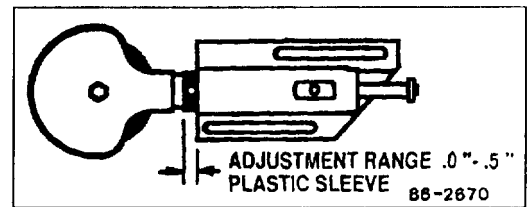

**ON BELT TENSION ADJUSTERS**  
(Part No. 86-2670)  
Belt Adjusting Procedure



**ON CUTTING DECK (5)**  
(Part No. 43-8480)  
Keep Hands & Feet Away

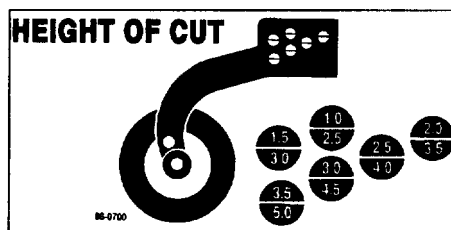

**ON RIGHT WING DECK**  
(Part No. 86-0700)  
Height-of-Cut Adjusting Procedure

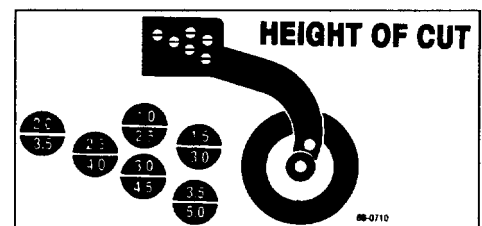

**ON LEFT WING DECK**  
(Part No. 86-0710)  
Height-of-Cut Adjusting Procedure

\* 84-1471 German, 84-1472 French, 84-1473 Dutch, 85-1474 Swedish, 85-1475 Spanish, 84-1476 Italian, 84-1477 Danish, 84-1478 Japanese.



# SAFETY AND INSTRUCTION DECALS

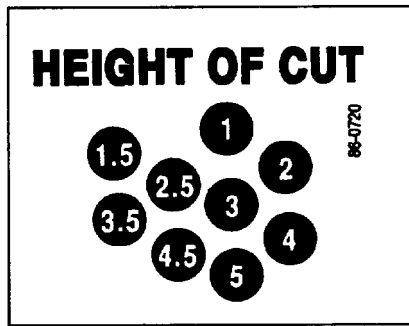

ON LEFT CASTOR ARM  
(Part No. 86-0720)  
Height-of-cut Adjusting Procedure

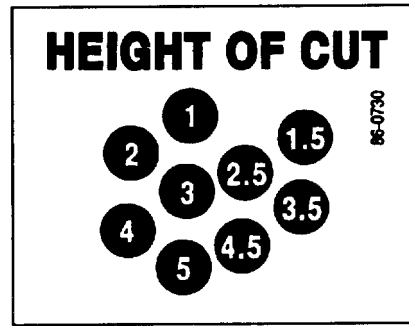

ON RIGHT CASTOR ARM  
(Part No. 86-0730)  
Height-of-Cut Adjusting Procedure

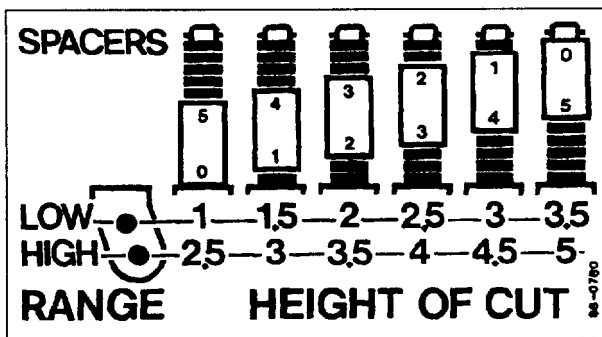

ON LEFT CASTOR ARM  
(Part No. 86-0780)  
Height-of-Cut Adjusting Procedure

**⚠ DANGER**

- HIGH SPEED PULLEYS AND BELTS CAN SERIOUSLY INJURE.
- DO NOT OPERATE THIS UNIT UNLESS ALL SHIELDS ARE SECURELY FASTENED.

85-6410

UNDER DECK COVERS  
(Part No. 85-6410)  
Replace Cover Before Operating

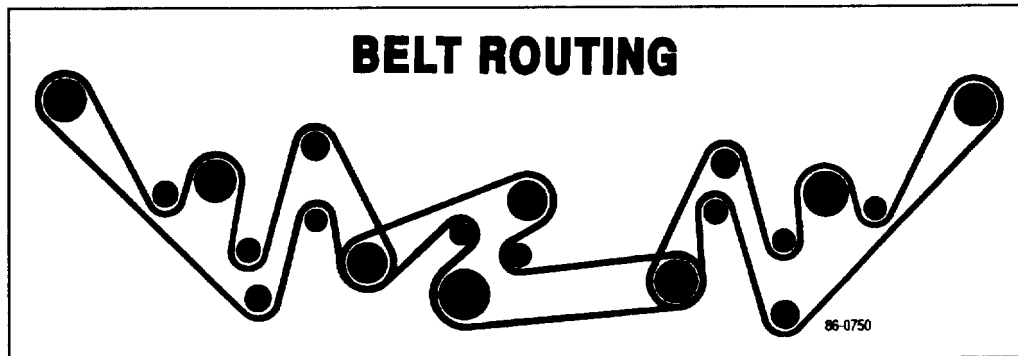

ON EACH CUTTING UNIT  
(Part No. 86-0740) Center Deck  
(Part No 86-0750) R.H. Wing Deck  
(Part No. 86-0760) L.H. Wing Deck  
Belt Routing

**⚠ WARNING**

**DO NOT PARK ON SLOPES UNLESS WHEELS ARE CHOCKED OR BLOCKED.**

92-1370

ON LEFT FLOOR PLATE  
(Part No. 92-1370)  
Parking Requirements

**⚠ WARNING**

**SPRING LOADED MECHANISM**

SEE OPERATOR'S MANUAL FOR DISASSEMBLY PROCEDURE. 66-4300

ON CUTTING DECKS (5)  
(Part No. 55-4300)  
Spring Loaded

**⚠ CAUTION**

**BLADE RETAINING BOLTS MUST BE TORQUED TO 85-110 ft-lbs. CHECK BLADE BOLT TORQUE AFTER STRIKING ANY SOLID OBJECT.**

68-8340

ON CENTER CUTTING DECK  
(Part No. 68-8340)  
Blade Bolt Torque



# SPECIFICATIONS

## TRACTION UNIT

**Engine:** Peugeot, four-cycle, four cylinder, 1.9 liter (1900 cc) displacement, liquid cooled diesel engine. 23.5:1 compression ratio. Low idle – 1500 rpm, high idle – 3000 rpm. Oil capacity is 5.3 qts. with filter.

**Cooling System:** Capacity is 3.5 gal. of 50/50 mixture of Peugeot recommended anti-freeze.

**Fuel System:** Capacity is 14 gal. of #1 or #2 diesel fuel.

**Hydraulic System:** Reservoir capacity is 6.5 gal. Replaceable spin-on filter element.

**Traction System:** Ground speed: Low Range; 0 - 6.5 m.p.h (0 – 5.5 m.p.h. with mechanical speed limiter interlock) forward and 0 -3 reverse. High Range; 0-15 mph (0 – 12.4 m.p.h. with mechanical speed limiter interlock) forward and 0-5 mph reverse.

**Front Axle:** Two speed axle is designed to withstand heavy duty slope operation and side loading. Separate mowing and transport selections for faster and more efficient machine operation. Neutral position allows easy towing. Lubricated with SAE 80-90 wt. EP gear lube. Capacity is 128 oz.

**Rear Axles:** Two Wheel Drive – The large diameter wheel spindles are designed for durability and long wear, yet provide superior stability and maneuverability. Four Wheel Drive - Heavy duty, agricultural type. Hydraulic drive with “on demand” over running clutch and balanced weight distribution provides superior traction on hillsides. Lubricated with SAE 80-90 wt. EP gear lube. Capacity is 80 oz.

**Tires/Wheels:** High flotation turf tread tires on de-mountable rims. Front tires: (2) 26 x 12.0–12, 8 ply. Rear tires: (2) 20 x 10.0–10, 6 ply. Tire pressure 20 psi.

**Seat:** Adjustable fore and aft travel and weight.

**Diagnostic System:** Test ports for: Forward and reverse traction (2 wheel drive), front and rear axle motors (4 wheel drive), lift and counterbalance circuit, steering circuit and charge circuit.

**Steering System:** Automotive type, full power.

**Brakes:** Totally enclosed, non asbestos, dry multi-disc 5-5/8” individual wheel and parking brakes on front traction wheels. Brakes controlled by individual pedals operated by the left foot. Dynamic braking through closed-loop hydrostatic drive.

**Electrical System:** 12 volt battery with 530 cold cranking Amps @ 0 ° F. 55 amp amp alternator, ammeter, starter, key switch and automatic temperature controlled glow plug controller. Separately fused, run, deck and instrument/accessory circuits.

**Interlock System:** Designed to stop engine if operator gets off seat while cutting deck drive switch is engaged or traction pedal is forward or reverse. Prevents engine from starting unless traction pedal is in neutral and cutting deck is disengaged. Prevents cutting deck from operating unless axle shift is in LO range.

### Warning Lights:

- Glow plug indicator
- Engine oil pressure warning
- Engine coolant temperature warning
- Charge indicator

### Indicators:

- Engine coolant temperature gauge
- Fuel gauge
- Hour meter

## CUTTING UNIT

**Type:** 126” width of cut, seven blade, front mounted rotary. 54” width of cut, three blade center section. Two 36” width of cut wings; 90” width of cut with one wing up. Rear discharge with even dispersion over the entire width of cut.

**Mowing Rate:** Mows up to 8 acres/hr. at 6.5 mph.

**Trimability:** Trims on both sides.

**Height-of-Cut:** Adjustable from 1” to 5” in 1/2” increments.

**Construction:** Housings are 12 gauge high strength steel, 5.5” deep, welded construction and reinforced with 10 gauge channel. Covers are impact resistant, molded plastic.

**Cutter Drive:** PTO driven gear box with 1:1 spiral bevel gears. Triple 3V section belt to center deck spindles, “A” section belt to each wing deck with patent-pending belt routing. 1–1/4 inch diameter, stressproof spindle shafts mounted on two greaseable, tapered roller bearings. A positive splined connection attaches pulleys to spindle shafts for high torque capacity.

**Blades:** Seven 19” long, 1/4” thick, and 2–1/2” wide, heat treated steel blades.

**Belt Idlers:** Self-tensioning permanently lubricated idlers.

**Wing Decks:** Wings can be hydraulically raised from the operator’s seat for transport or cutting with either wing and center deck or center deck only. Wings cut from level to 15° up and down. Further lift disengages the blade and applies a blade brake.

**Suspension / Caster Wheels:** Four front and two rear castor tires consist of solid rubber and ball bearings. Center deck tires: 10.25” x 3.25”. Wing deck tires: 8” x 3.25”. Anti-scalp cup located on each blade. Three anti-scalp rollers on center deck. Deck is hydraulically counterbalanced.

# SPECIFICATIONS

## GENERAL SPECIFICATIONS (approx.):

<b>Overall Length:</b>	
With deck installed	134 in.
<b>Overall Width:</b>	
Transport	75 in.
Mowing	127 in.
<b>Height:</b>	58 in.
With ROPS installed	82 in.
<b>Wheel Tread:</b>	
(Front)	52 in.
(Rear)	44 in.
<b>Wheel Tread:</b>	56 in.

## Dry Weight:

2 Wheel Drive	3,450 lbs.
4 Wheel Drive	3,550 lbs.

## OPTIONAL EQUIPMENT

Roll Over Protection Kit, Contact Your Local Toro Distributor (Standard on Model 30455)

Canopy Kit, Contact Your Local Toro Distributor

Spark Arrestor Muffler, Part No. 77-3990

Gear Box Pulley (Tip Speed 14,500), Part No. 86-3100

Pre-cleaner Kit, Part No. 92-2574

Specifications and design subject to change without notice.

## LOOSE PARTS CHART

Ignition Key	1	
Operator's Manual	2	Read before operating machine.
Parts Catalog	1	
Registration Card	1	Fill out and return to Toro
Commercial Product Set-Up Card	1	

## BEFORE OPERATING

CAUTION

Before servicing or making adjustments to the machine, stop engine and remove key from the switch.

### CHECK ENGINE OIL (Fig. 1 & 2)

Crankcase capacity is 5.3 qt. with filter.

1. Park machine on a level surface. Release hood latch and open hood.



**Figure 1**  
1. Hood Latch

2. Remove dipstick from tube cap, wipe clean and reinstall dipstick into tube cap. Pull it out again and check oil level on dipstick: Oil level must always be in notch area on dipstick.

3. If oil level is low, remove tube cap and add SAE 10W-30 CD oil until level reaches top of notch on dipstick. DO NOT OVERFILL.

4. Install oil tube cap.

5. Close hood and secure latch.

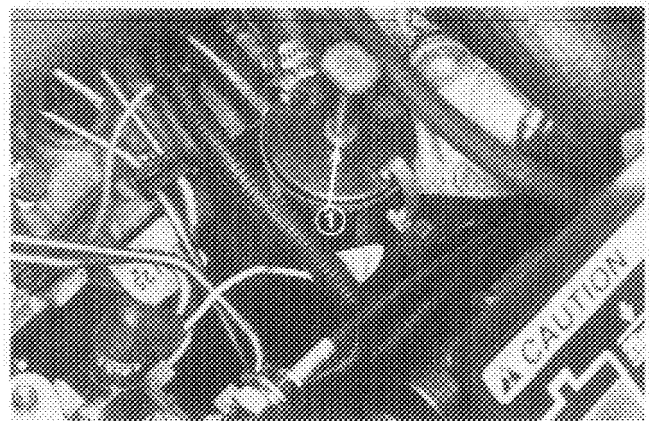

**Figure 2**  
1. Dipstick / Tube Cap

# BEFORE OPERATING

## CHECK COOLING SYSTEM (Fig. 3)

Capacity of system is 3.5 gal.

1. Park machine on a level surface. Release hood latch and open hood.
2. Coolant level should be up to or above mounting tabs on degasser tank, when engine is cold.

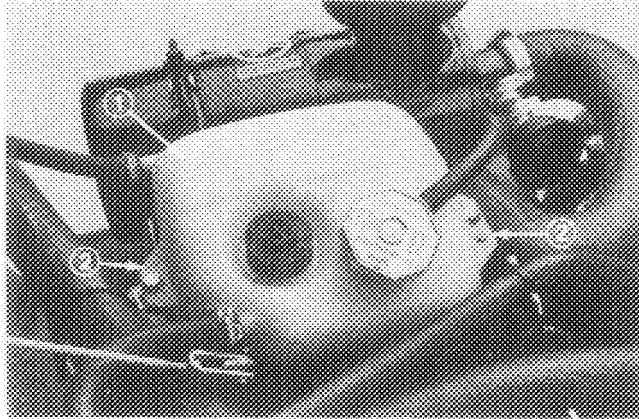

Figure 3

1. Degasser Tank      2. Mounting Tabs

3. If coolant is low, remove degasser tank cap and add a 50/50 mixture of water and Peugeot recommended anti-freeze. **DO NOT USE WATER ONLY OR ALCOHOL/METHANOL BASE COOLANTS.**

**IMPORTANT: Do not remove black plastic cap on degasser tank.**

4. Install degasser tank cap.
5. Close hood and secure latch.

## FILL FUEL TANK (Fig. 4)

1. Park machine on a level surface. Release hood latch and open hood.
2. Remove fuel tank cap.

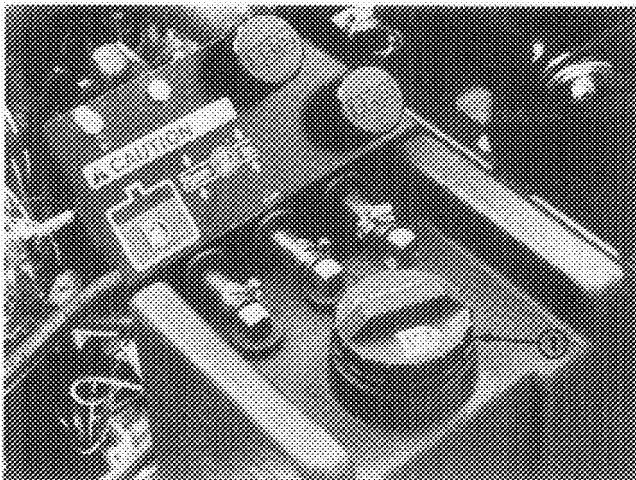

Figure 4

1. Fuel Tank Cap

3. Fill tank to no more than one inch below bottom of filler neck with No. 2 diesel fuel. **DO NOT OVER FILL.** Then install cap.

**Note:** For temperatures below 32° F., No. 1 diesel fuel or a blend should be used.



**DANGER**

**Because diesel fuel is highly flammable, use caution when storing or handling it. Do not smoke while filling the fuel tank. Do not fill fuel tank while engine is running, hot, or when machine is in an enclosed area. Always fill fuel tank outside and wipe up any spilled diesel fuel before starting the engine. Store fuel in a clean, safety-approved container and keep cap in place. Use diesel fuel for the engine only; not for any other purpose.**

4. Close hood and secure latch.

## CHECK HYDRAULIC CIRCUIT OIL (Fig. 5)

The hydraulic system is designed to operate on Mobil DTE 26 or equivalent anti-wear hydraulic fluid. The machine's reservoir is filled at the factory with approximately 6.5 gallons of fluid. However, check level of hydraulic fluid before engine is first started and daily thereafter.

### Hydraulic Oil (Recommended brands):

Mobil	DTE 26
Shell	Tellus 68
Amoco	Rykon Oil #68
Conoco	Super Hydraulic Oil 68
Exxon	Nuto 68
Kendall	Kenoil R&O AW 68
Pennzoil	Penreco 68
Phillips	Magnus A 68
Standard	Energol HLP 68
Sun	Sunvis 831 WR
Union	Unax AW 68
Chevron	AW Hydraulic Oil 68

**Note:** All are interchangeable.

**IMPORTANT: Use only hydraulic oils specified. Other fluids could cause system damage.**

**Note:** A red dye additive for the hydraulic system oil is available in 2/3 oz. bottles. One bottle is sufficient for 4–6 gal. of hydraulic oil. Order Part No. 44–2500 from your Authorized Toro Distributor

# BEFORE OPERATING

1. Park machine on a level surface. Make sure machine has been operated so oil is warm. Release hood latch and open hood. Check level of oil by viewing sight gauge. If oil is visible in gauge, oil level is sufficient.

2. If oil level is not visible in gauge, remove cap from hydraulic oil reservoir and slowly add Mobil DTE 26 or equivalent hydraulic oil until level reaches middle (maximum) of sight gauge. **DO NOT OVER FILL.**

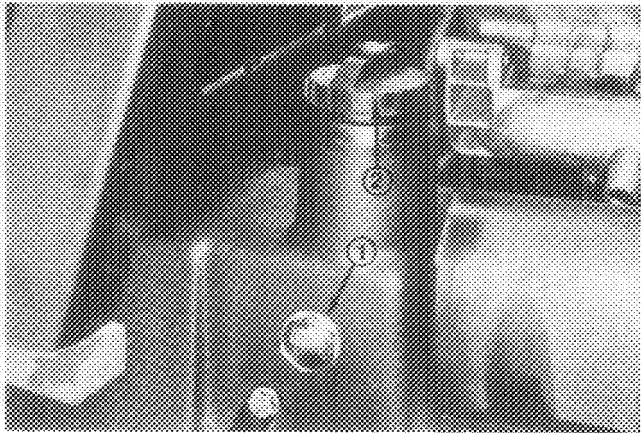

Figure 5

1. Sight Gauge 2. Hydraulic Reservoir Cap

**IMPORTANT:** To prevent system contamination, clean top of hydraulic oil containers before puncturing. Assure pour spout and funnel are clean.

3. Install reservoir cap, close hood and secure latch.

## CHECK FRONT AXLE OIL LEVEL

(Fig. 6 & 7)

The front axle is shipped from the factory filled with SAE 80–90 wt. gear lube. However, check level before engine is first started and every 50 hours thereafter. Capacity is 128 oz.

1. Park machine on a level surface.
2. Remove access panel (Fig. 6), in front of seat, to expose front axle / dipstick.

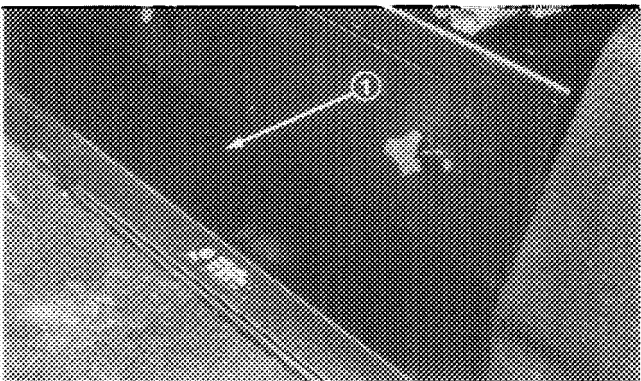

Figure 6

1. Access Panel

3. Unscrew dipstick cap (Fig. 7) from the filler neck and wipe it with a clean rag. Screw dipstick cap finger tight onto filler neck. Unscrew the dipstick and check level of lubricant. If level is not within 1/2 inch from the groove in the dipstick, add enough to raise level to groove mark. **DO NOT OVERFILL** by more than 1/2 inch above groove.

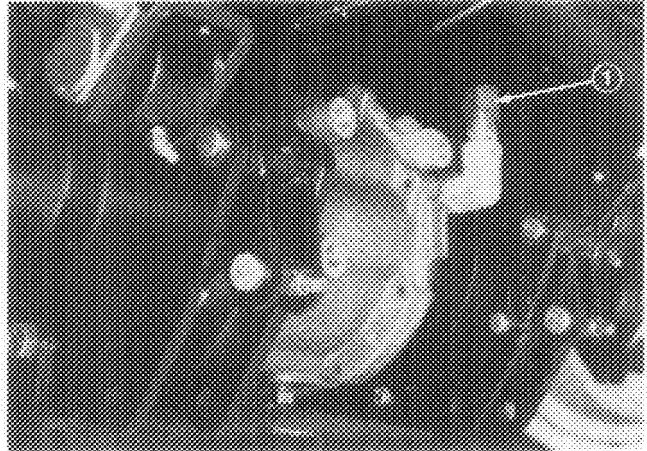

Figure 7

1. Dipstick Cap

4. Screw dipstick filler cap finger-tight onto filler neck. It is not necessary to tighten cap with a wrench.

## CHECK REAR AXLE LUBRICANT (Model 30455 Only) (Fig. 8)

The rear axle is shipped from the factory filled with SAE 80–90 wt. gear lube. However, check level before engine is first started and every 50 hours thereafter. Capacity is 80 oz.

1. Position the machine on a level surface.
2. Remove a check plug from one end of axle and make sure lubricant is up to bottom of hole. If level is low, remove the fill plug and add enough lubricant to bring the level up to the bottom of the check plug holes.

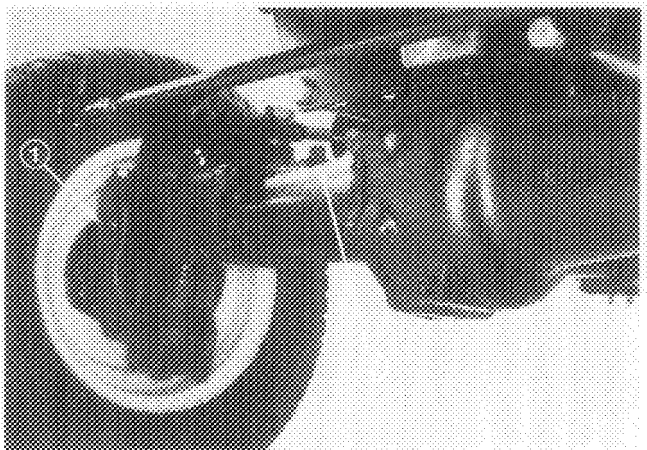

Figure 8

1. Check Plug 2. Fill Plug

# BEFORE OPERATING

## CHECK TIRE PRESSURE

The tires are over-inflated for shipping. Therefore, release some of the air to reduce the pressure. Correct air pressure in the front and rear tires is 20 psi.

**IMPORTANT:** Maintain even pressure in all tires to assure a good quality-of-cut and proper machine performance. **DO NOT UNDER INFLATE.**

## CHECK TORQUE OF WHEEL NUTS OR BOLTS

WARNING

Torque front wheel nuts to 45-55 ft-lb and rear wheel nuts or bolts to 85-100 ft-lb after 1-4 hours of operation and again after 10 hours of operation and every 250 hours thereafter. Failure to maintain proper torque could result in failure or loss of wheel and may result in personal injury.

## CHECK LUBRICANT IN GEAR BOX

(Fig. 9)

The gear box is designed to operate on SAE 80-90 wt. gear lube. Although the gear box is shipped with lubricant from the factory, check the level before operating the cutting unit.

1. Position the machine and cutting unit on a level surface.
2. Remove check plug from side of gear box and make sure lubricant is up to bottom of hole. If level of lubricant is low, remove fill plug on top of gear case and add enough lubricant to bring it up to bottom of hole in side.

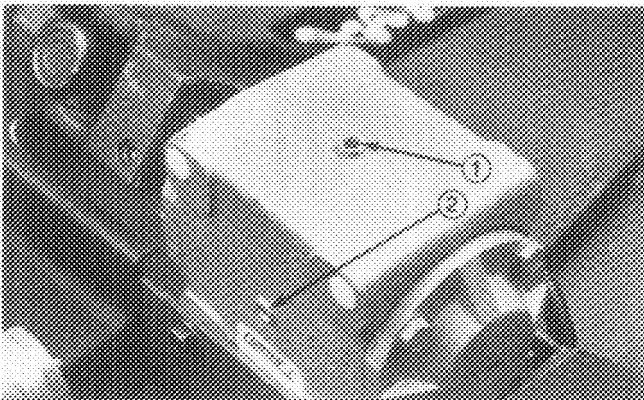

Figure 9

1. Filler Plug
2. Check Plug

## ADJUSTING HEIGHT-OF-CUT

(Fig. 10-12)

The height-of-cut is adjustable from 1 to 5 inches in 1/2 inch increments. Positioning the castor wheel axles in the top holes of the castor forks or pivots (See chart below) allows low range height-of-cut settings from 1 to 3-1/2 in.; positioning the castor wheel axles in the lower holes of the front castor forks or rear castor pivots (See chart below) allows high range height-of-cut settings from 2-1/2 to 5 in.

### Height-of-Cut Charts

**SPACERS**

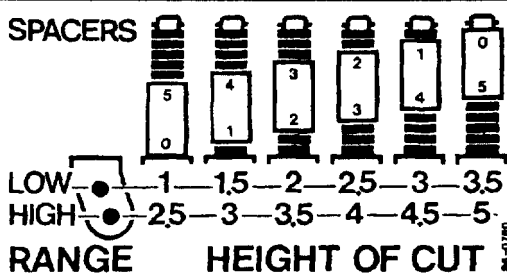

**LOW RANGE**      **HEIGHT OF CUT**

**HIGH RANGE**      **HEIGHT OF CUT**

**Front Castor Wheels**

### HEIGHT OF CUT

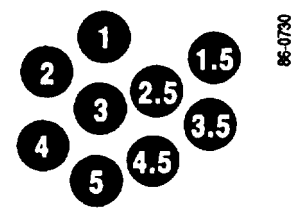

**Rear Castor Wheels**

### HEIGHT OF CUT

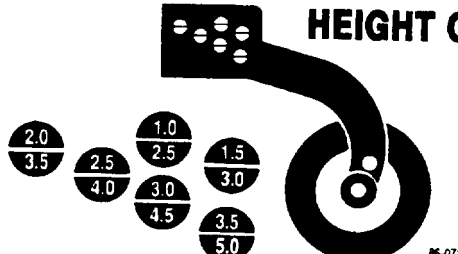

**Rear Deck Straps**

1. Start the engine and raise the cutting unit so height-of-cut can be changed. Stop engine after cutting unit is raised.

2. Position all castor wheel axles in the same holes in the castor forks or pivots.

### FRONT CASTOR WHEELS

1. Remove lynch pin from spindle shaft and slide spindle out of front castor arm. Slide spacers onto spindle shaft to get desired height-of-cut.

2. Push castor spindle through front castor arm install remaining spacers onto spindle and install lynch pin to secure assembly.

# BEFORE OPERATING

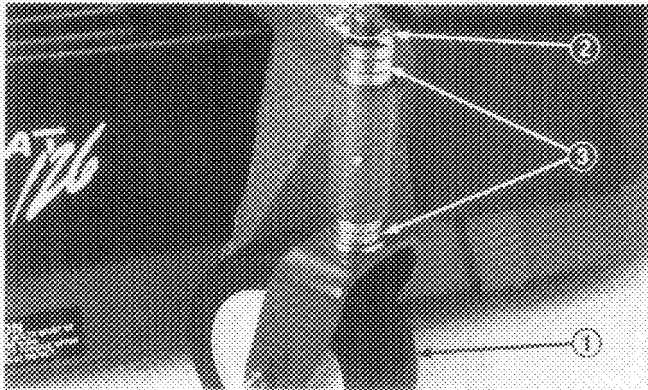

**Figure 10**  
 1. Front Castor Wheel  
 2. Lynch Pin  
 3. Spacers

## REAR CASTOR WHEELS

1. Remove hairpin cotter and H.O.C. pin securing rear castor pivot arm to deck bracket.

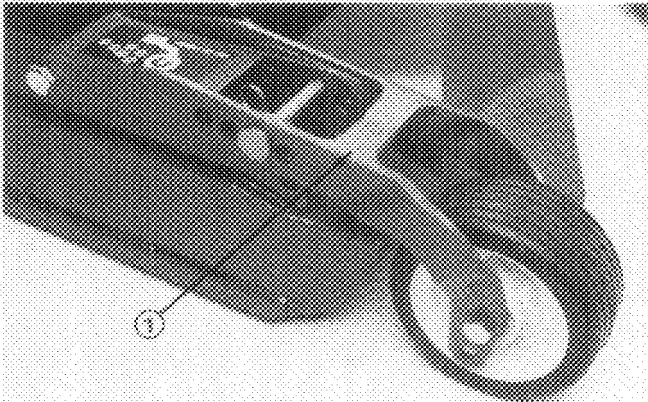
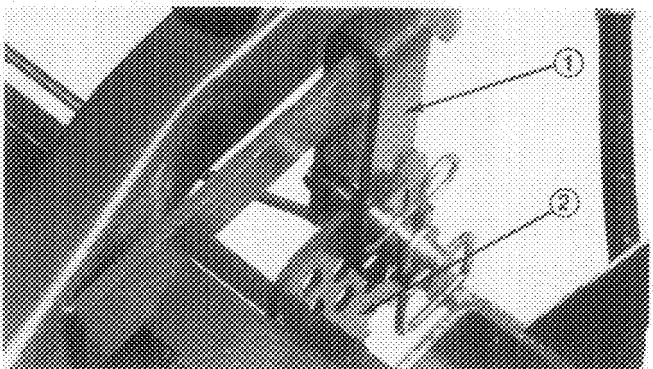

**Figure 11**  
 1. Rear Castor Pivot

2. Align the pivot arm holes with selected height-of-cut bracket holes in the deck frame, install H.O.C. pin and secure with hairpin cotter.

## REAR DECK STRAPS

1. Lower center and wing cutting units to the ground; then raise center cutting unit slightly, until rear deck straps hang freely on lift arm brackets. Stop engine after cutting unit is raised.



**Figure 12**  
 1. Rear Deck Straps  
 2. Lift Arm Brackets

2. Remove hairpin cotter and H.O.C. pin securing rear deck strap to H.O.C. bracket on deck.

3. Slide deck strap forward or backward until holes in strap are aligned with selected height-of-cut bracket holes in the deck frame, install H.O.C. pin and secure with hairpin cotter.

## SAFETY DOORS (Fig. 13)

On each side of the center deck is a safety door that opens and closes as the wing decks are lowered and raised (Fig. 13). The doors open to provide overlap of the cutting blades when the wing units are down. The doors close to provide safety and protection when the wing units are raised. Check to make sure the forward, lower edge of door is even or 1/4" higher than lower edge of door guide when wing decks are in the fully raised, transport position. If an adjustment to the door is required, refer to Adjusting Safety Door, page 33.

CAUTION

Check for proper operation of the safety doors each time the deck is cleaned and repair as needed.

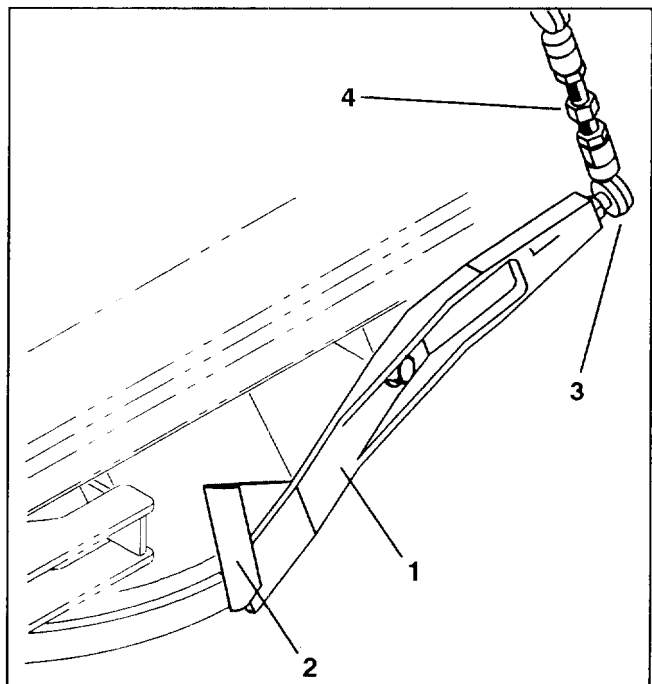
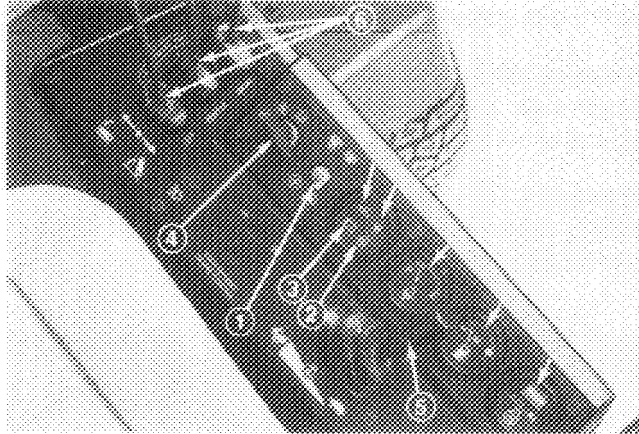

**Figure 13**

- |                |                 |
|----------------|-----------------|
| 1. Safety Door | 3. Ball Joint   |
| 2. Door Guide  | 4. Threaded Rod |

# KNOW YOUR CONTROLS

**Cutting Unit Engagement Switch** (Fig. 14) – Used to start and stop cutting unit operation. Lift switch and move forward to actuate cutting unit. Center deck will engage first followed by wing decks engaging approximately one second later.



**Figure 14**

- |                                   |  |
|-----------------------------------|--|
| 1. Cutting Unit Engagement Switch | 7. Coolant Temperature Gauge                 |
| 2. Glow Plug Indicator            | 8. Fuel Gauge                                |
| 3. Charge Indicator               | 9. Hour Meter                                |
| 4. Key Switch                     | 10. Engine Oil Pressure Warning Light        |
| 5. Throttle Control               | 11. Engine Coolant Temperature Warning Light |
| 6. Cutting Unit Lift Controls     |  |

**Glow Plug Indicator** (Fig.14) – Automatically actuates proper glow period when ignition key is turned to ON position. Illuminates when glow plugs are actuated. When glow plugs are heated sufficiently, light goes off indicating engine is ready to start.

**Charge Indicator** (Fig.14) – Illuminates when system charging circuit malfunctions.

**Key Switch** (Fig. 14) – Three positions: OFF, ON and START. Rotate key to START and release key when engine begins running. To stop engine, rotate key to OFF.

**Throttle Control** (Fig. 14) – Move control forward to increase engine speed, backward to decrease speed.

**Cutting Unit Lift Controls** (Fig. 14) – The two outside levers raise and lower the wing cutting units. The center lever raises and lowers the whole cutting unit. Engine must be running to lower cutting unit. When wing cutting units are raised higher than 15°, blades automatically disengage. To lower cutting unit just touch levers momentarily.

**Coolant Temperature Gauge** (Fig. 14) – Shows temperature of engine coolant.

**Fuel Gauge** (Fig. 14) – Shows amount of fuel in tank.

**Hour Meter** (Fig. 14) – Shows total hours that machine has been operated.

**Engine Oil Pressure Warning Light** (Fig. 14) – Indicates dangerously low engine oil pressure.

**Engine Coolant Temperature Warning Light** (Fig. 14) – The red light illuminates and the engine stops when temperature of coolant exceeds 230°F.

**Seat** (Fig. 15) – Seat adjusting lever on left side of seat allows 4 inch fore and aft adjustment. Seat adjusting knob on front of seat, adjusts seat for operators weight.

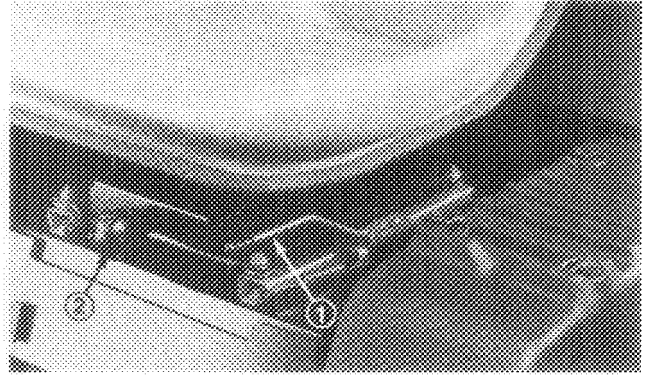

**Figure 15**

1. Seat Adjusting Lever 2. Seat Adjusting Knob

**Traction Pedal** (Fig. 16) – Controls forward and reverse operation. Depress top of pedal to move forward and bottom to move backward. Ground speed depends on how far pedal is depressed. For no load, maximum ground speed, fully depress pedal while throttle is in FAST. For maximum power under load or when going uphill, keep engine rpm high by having throttle in FAST and traction pedal partially engaged. If engine rpm begins to decrease due to load, gradually reduce traction pedal pressure until engine speed is increased.

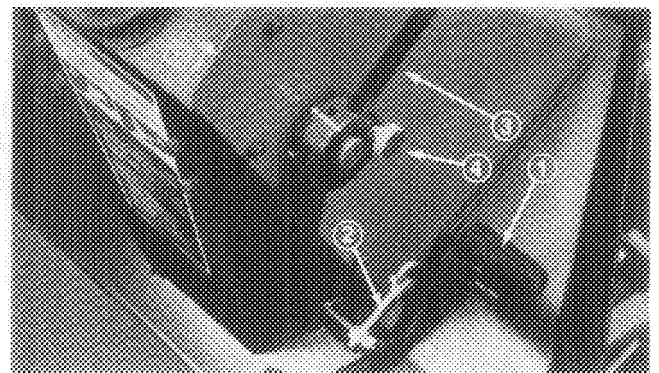

**Figure 16**

1. Traction Pedal 3. Axle Shift Lever  
2. Speed Selector 4. Lockout Knob

To stop, reduce foot pressure on traction pedal and allow it to return to center position. On extreme downhill slopes, apply pressure to REVERSE side of pedal, or operate with heel on REVERSE and toe on FORWARD portion of pedal.

**Speed Selector** (Fig.16) - Cam lever at side of traction pedal can be rotated to maintain desired speed. Rotating lever forward decreases speed and backward increases speed.

# KNOW YOUR CONTROLS

**Axle Shift Lever** (Fig. 16) – Located on right side of console, lever selects front drive mode. Pull out lockout knob, move lever rearward for mowing operation and forward for transport operation, then release knob to lock selection. Lever must be in LO position to mow. Middle position (N) is for towing.

**IMPORTANT:** On model 30455, lever must be in LO position to operate in 4-wheel drive.

**CAUTION:** Machine must be on a flat surface and brakes engaged when shifting axle from HI to LO position.

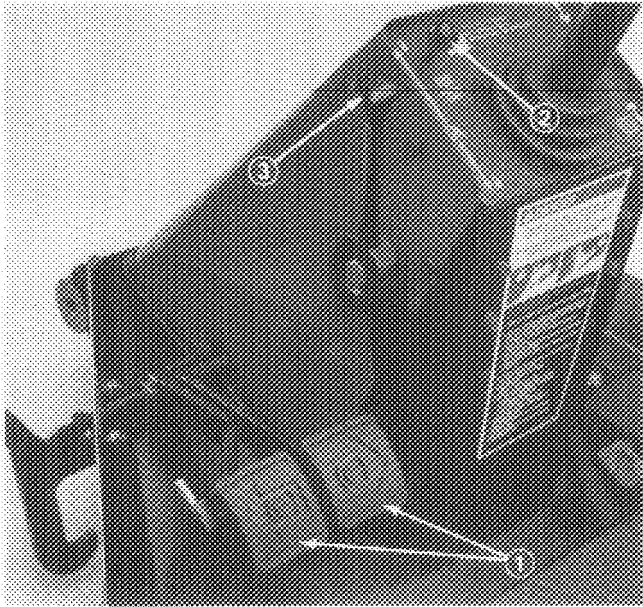

**Figure 17**

1. Brake Pedals
2. Parking Brake Latch
3. Steering Wheel Tilt Lever

**Brake Pedals** (Fig. 17) – Two foot pedals at the lower left operate individual wheel brakes for turning assistance, braking, parking and to aid in obtaining better sidehill traction. Locking pin is for parking.

**Parking Brake Latch** (Fig. 17) – A knob on the left side of console actuates parking brake lock. To engage parking brake, connect pedals with locking pin, push down on both pedals and pull parking brake latch out. To release parking brake, depress both pedals until parking brake latch retracts.

**Steering Wheel Tilt Lever** (Fig. 17) – Lever on left side of console allows steering wheel to be adjusted for operator comfort.

**Transport Latches** (Fig. 18) – Four latches secure cutting unit and wings in upright position for transport operation.

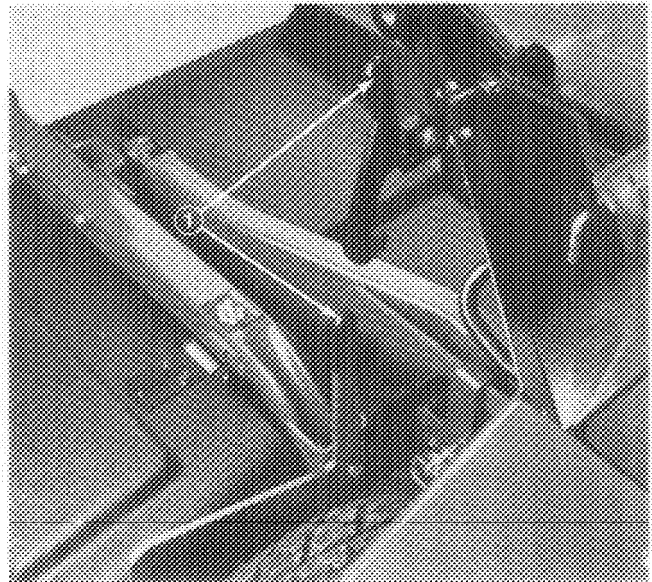

**Figure 18**

1. Transport Latch (4)

**Horn** – In center of steering wheel. Operates only when key switch is in ON.

## OPERATING INSTRUCTIONS

### STARTING AND STOPPING

1. Sit on the seat, keep foot off traction pedal. Assure parking brake is engaged, traction pedal is in NEUTRAL and cutting unit engagement switch is in the DISENGAGED position.
2. Turn ignition switch to ON position. When glow indicator light goes off, engine is ready to START.
3. Turn ignition key to START. Release key when engine starts.
4. To stop, disengage and move all controls to NEUTRAL and set parking brake. Turn key to OFF and remove it from switch. Raise and latch all cutting units in transport position.

### PRIMING FUEL SYSTEM (Fig. 19 & 20)

**IMPORTANT:** The fuel system may need to be primed when a new engine is started for the first time, if it runs out of fuel or if maintenance is performed on the fuel system.

1. Unlatch and raise hood.
2. Insert a 3/16" hose over bleed screw and run other end into a container to catch fuel.
3. Loosen fuel filter / water separator bleed screw (Fig. 19) a few turns. Pump priming plunger until a steady stream of fuel comes out of hole in bleed screw. When fuel stops foaming, tighten the bleed screw during the downstroke of the priming plunger. Wipe up any spilled fuel.



# OPERATING INSTRUCTIONS

4. Pump priming plunger until resistance is felt. Try to start engine. If engine does not start repeat step 3.

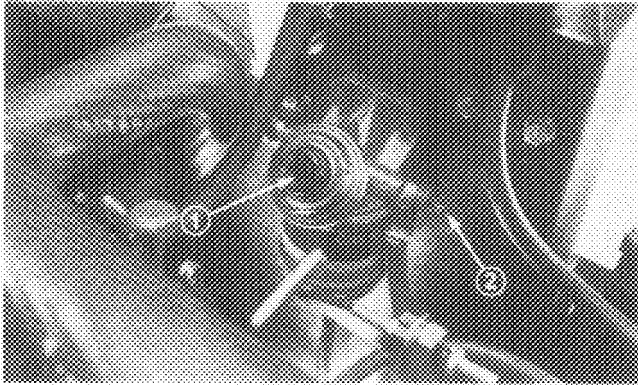

**Figure 19**  
1. Primer Plunger 2. Bleed Screw

**Note:** It may be necessary to bleed the air out of the fuel line between the fuel filter / water separator and the injection pump. To do this, loosen the fitting on the injection pump (Fig. 20) and repeat bleeding procedure.

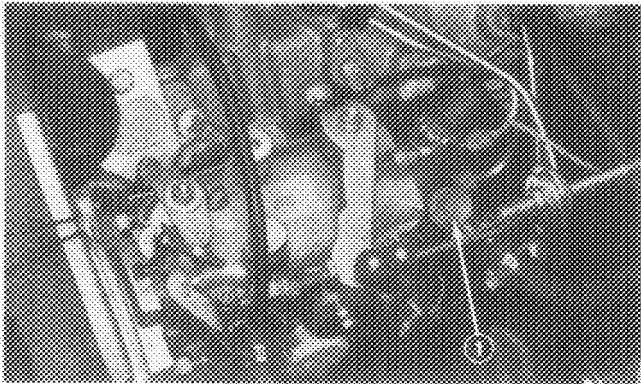

**Figure 20**  
1. Injection Pump Fitting

## CHECKING INTERLOCK SYSTEM.

The purpose of the interlock system is to prevent the engine from cranking or starting unless the traction pedal is in NEUTRAL and the cutting unit engagement switch is DISENGAGED. In addition, the engine will stop when the cutting unit engagement switch is engaged or traction pedal is depressed with operator off the seat.

1. In a wide open area free of debris and bystanders, lower cutting unit to the ground. Stop engine.
2. Move cutting unit engagement switch to DISENGAGED position and remove foot from traction pedal so it is fully released.
3. Rotate the ignition key to START. Engine should start. If engine starts, proceed to step 4. If engine does not start, there may be a malfunction in the interlock system.

4. Raise off the seat and engage the cutting unit engagement switch while the engine is running. The engine should stop within 2 seconds. If engine stops, the switch is operating correctly; thus, proceed to step 5. If engine does not stop, there is a malfunction in the interlock system.

6. Raise off the seat and depress the traction pedal while engine is running and the cutting unit engagement switch is DISENGAGED. The engine should stop within 2 seconds. If engine stops, the switch is operating correctly; thus, continue operation. If engine does not stop, there is a malfunction in the interlock system.



## CAUTION

THE INTERLOCK SWITCHES ARE FOR THE OPERATOR'S PROTECTION, SO DO NOT DISCONNECT THEM. CHECK OPERATION OF THE SWITCHES DAILY TO ASSURE INTERLOCK SYSTEM IS OPERATING. IF A SWITCH IS DEFECTIVE, REPLACE IT BEFORE OPERATING. REGARDLESS IF SWITCHES ARE OPERATING PROPERLY OR NOT, REPLACE THEM EVERY TWO YEARS TO ASSURE MAXIMUM SAFETY. DO NOT RELY ENTIRELY ON SAFETY SWITCHES – USE COMMON SENSE!

## OPERATING CHARACTERISTICS

**Familiarization** – Before mowing grass, practice operating machine in an open area. Start and stop the engine. Operate in forward and reverse. When you feel familiar with the machine, practice operating around trees and obstacles. Also drive up and down slopes at different speeds.

**WARNING:** When operating 4 wheel drive machine, always use the seat belt and ROPS together and have seat pivot retaining pin installed.

Another characteristic to consider is the operation of the brake pedals. The brakes can be used to assist in turning the machine. However, use them carefully, especially on soft or wet grass because the turf may be torn accidentally. Another benefit of the brakes is to maintain traction. For example: When operating on a sidehill, the uphill wheel slips and loses traction. If this situation occurs, depress uphill brake pedal gradually and intermittently until the uphill wheel stops slipping, thus, increasing traction on the downhill wheel.

# OPERATING INSTRUCTIONS

**Warning System** – If a warning light comes on during operation, stop the machine immediately and correct the problem before continuing operation. Serious damage could occur if the machine is operated with a malfunction.

**Mowing** – When you are at the area to be mowed, release cutting unit transport latches.

Move axle shift lever rearward to Mow position and throttle to FAST so engine is running at maximum speed. Lift engagement switch and move forward to engage cutting units.

**Curbside Mowing** – To reduce the possibility of foreign debris escaping from under the cutter deck while mowing at or near a road or walkway curb, always keep the outside edge of the cutter deck inside the curb. The cutter deck caster wheels should not be guided along the top of the curb; this could cause the cutter deck to hang over the edge of the curb. Never allow the edge of the cutter deck to extend over the edge of the curb while the blades are turning. Always stop mowing and disengage the mower blades when encountering pedestrians or other bystanders/passers-by.

**Note:** Cutting deck is equipped with a breakaway system to prevent wing decks from being damaged if a solid object is struck. If a wing deck strikes a solid object and unlatches from center cutting deck, raise and lower wing deck to reset in operating position.

**WARNING:** Cutting deck breakaway system is equipped with a highly compressed spring. If spring removal or repair is required, contact your local authorized Toro Distributor for assistance.

**Transport** – When mowing is complete, disengage cutting unit and raise it by pulling back on cutting unit lift control levers. Hold levers back until cutting unit is fully raised. **Never raise cutting deck when engaged.** Lock cutting unit in place with transport latches. Move axle shift lever forward to HI position. When driving from one area to another, always shift axle to LO position before encountering a slope. Never shift from HI to LO position while on a slope. Stop machine on a flat surface, engage brakes and shift before climbing the slope. Be careful when driving between objects so you do not accidentally damage the machine or cutting unit.

**Use extra care when operating machine on slopes. Drive slowly and avoid sharp turns on slopes to prevent roll overs. The cutting unit must be lowered when going downhill for steering control.**

**Pushing Or Towing Traction Unit** – Use only a rigid tow bar if it becomes necessary to tow machine. Make

sure axle shift lever is in NEUTRAL position and only tow the machine forward. Use trailer for normal transport. Move axle shift lever to LO position before loading machine on a trailer.

## OPERATING TIPS

**Mow When Grass Is Dry**—Mow either in the late morning to avoid the dew, which causes grass clumping or in late afternoon to avoid the damage that can be caused by direct sunlight on the sensitive, freshly mowed grass.

**Select The Proper Height-of-cut Setting To Suit Conditions** – Remove approximately one inch or no more than 1/3 of the grass blade when cutting. In exceptionally lush and dense grass you may have to raise your height-of-cut setting another notch.

**Mowing In Extreme Conditions** – Air is required to cut and recut grass clippings in mower housing, so do not set height-of-cut too low or totally surround housing by uncut grass. Always try to have one side of the mower housing free from uncut grass, allowing air to be drawn into housing. When making an initial cut thru center of uncut area, operate machine slower and back up if mower starts to clog.

**Clippings Discharge** – Although the deck has rear discharge, some clippings are discharged toward the left side. To avoid discharging undesirable clippings onto pathways, roads, or other non-turf surfaces, mow with the right side of the deck next to the pathway, road, or other non-turf surface

**Mow At Proper Intervals** – Under most normal conditions you'll need to mow approximately every 4–5 days. But remember, grass grows at different rates at different times. This means that in order to maintain the same height-of-cut, which is a good practice, you'll need to cut more frequently in early spring; as the grass growth rate slows in mid summer, cut only every 8–10 days. If you are unable to mow for an extended period due to weather conditions or other reasons, mow first with the height-of-cut at a high level; then mow again 2–3 days later with a lower height setting.

**Always Mow With Sharp Blades** – A sharp blade cuts cleanly and without tearing or shredding the grass blades like a dull blade. Tearing and shredding causes the grass to turn brown at the edges which impairs growth and increases susceptibility to diseases.

**After Operating** – To assure optimum performance, clean underside of mower housings and under belt covers after each use. If residue is allowed to build up in mower housings, cutting performance will decrease.

# SERVICE INTERVAL CHARTS

## 2 Wheel Drive

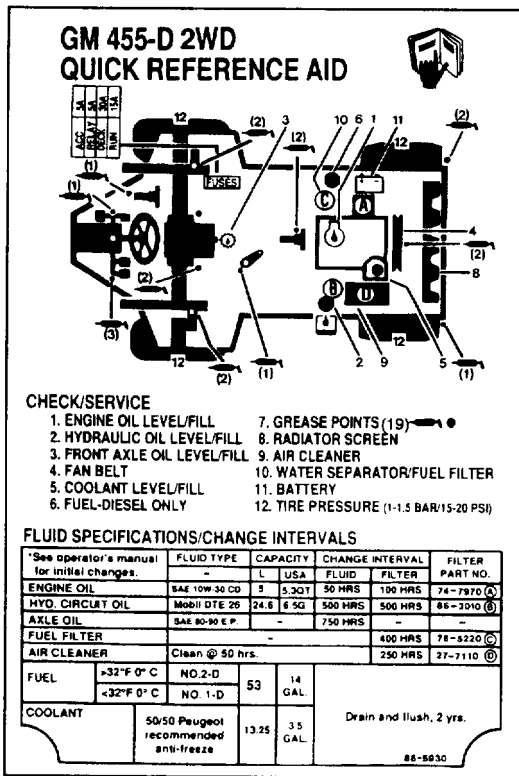

## 4 Wheel Drive

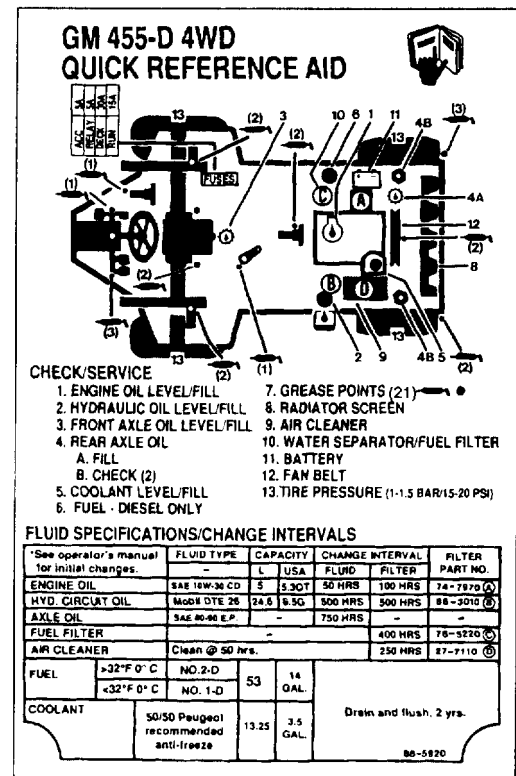

# LUBRICATION

## GREASING (Fig. 21-33)

The traction unit and cutting unit have grease fittings that must be lubricated regularly with No. 2 General Purpose Lithium Base Grease. If machine is operated under normal conditions, lubricate all grease fittings after every 25 hours of operation.

1. The grease fittings that must be lubricated are: Lift arm pivot (2), lift cylinder (2), brake arm pivots (2) (Fig. 21); brake pivot (1), brake pivots (2) (Fig. 22); traction pedal pivot (1) (Fig. 23); engine to pump drive shaft (2) (Fig. 24 & 25); traction adjuster (1) (Fig. 26); P.T.O. Bearing (Fig. 27).

2 wheel drive machines only – cylinder end (2) center pivot (1), spindles (2) (Fig. 28).

4 wheel drive machines only – tie rod assemblies (2), center pivot (1), axle knuckles (2) (Fig. 29); cylinder ends (2) (Fig. 30).

Cutting deck (2 & 4 wheel drive machines) – blade spindles (7) and Wing Deck Pivot pins (4) (Fig. 31); castor wheels (6); Castor fork shaft (4) (Fig. 32); Lift arm ball joints (2) and PTO to gear box drive shaft assembly (3) (Fig. 33).

1. Wipe grease fittings clean before lubricating.
2. Pump grease into fitting.
3. Wipe up excess grease.

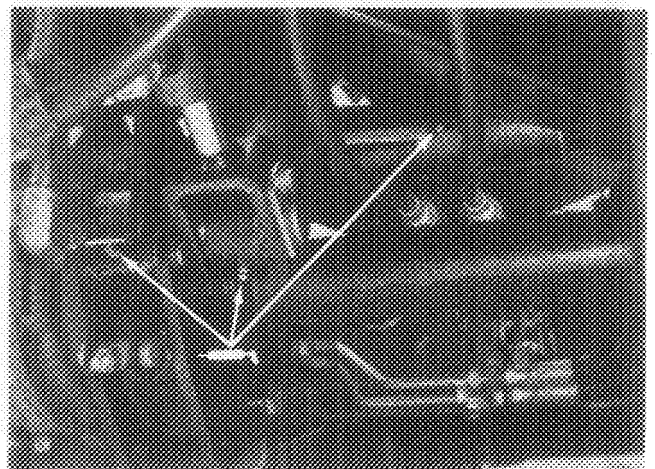

Figure 21

# LUBRICATION

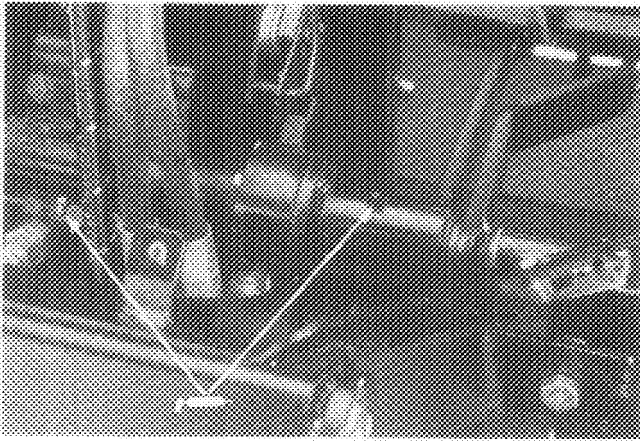

Figure 22

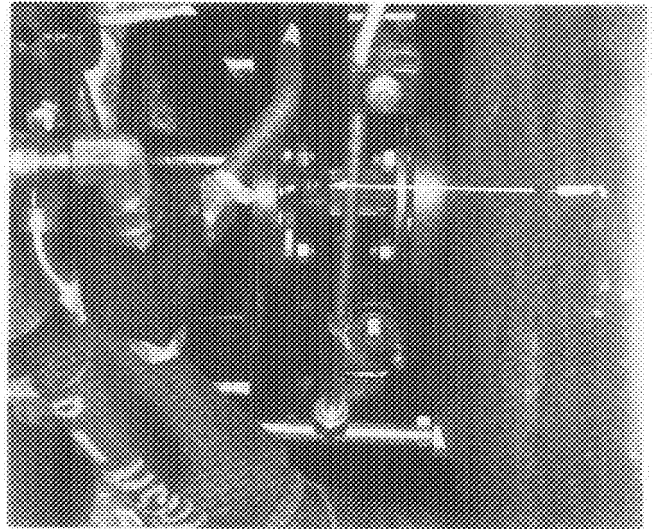

Figure 25

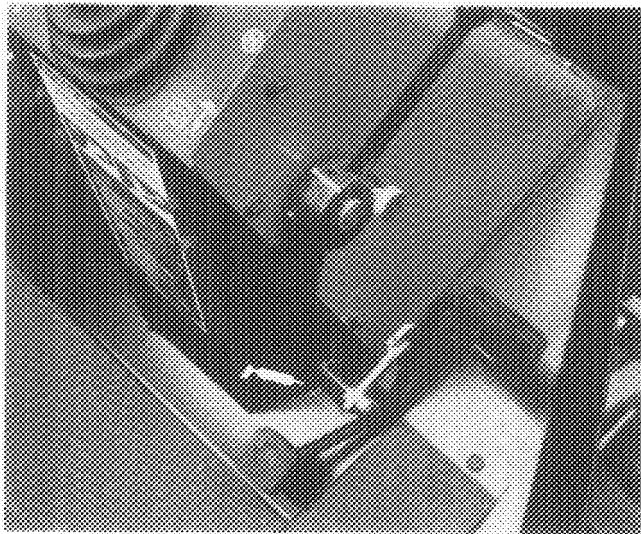

Figure 23

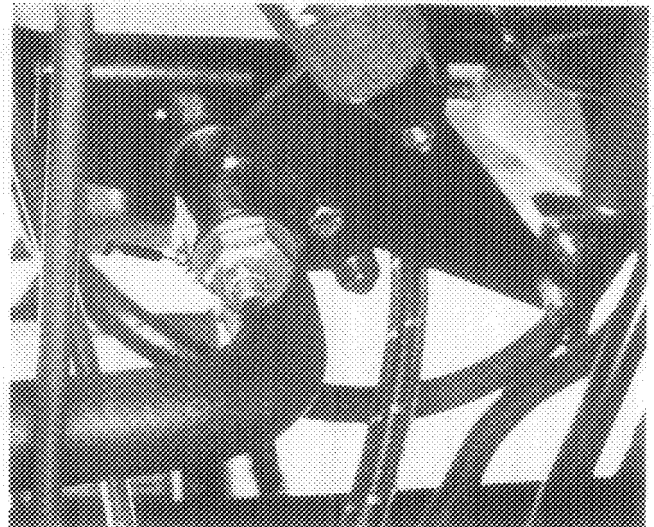

Figure 26

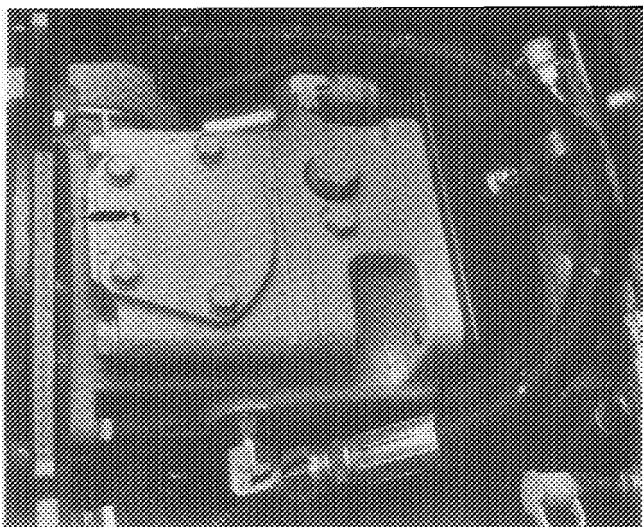

Figure 24

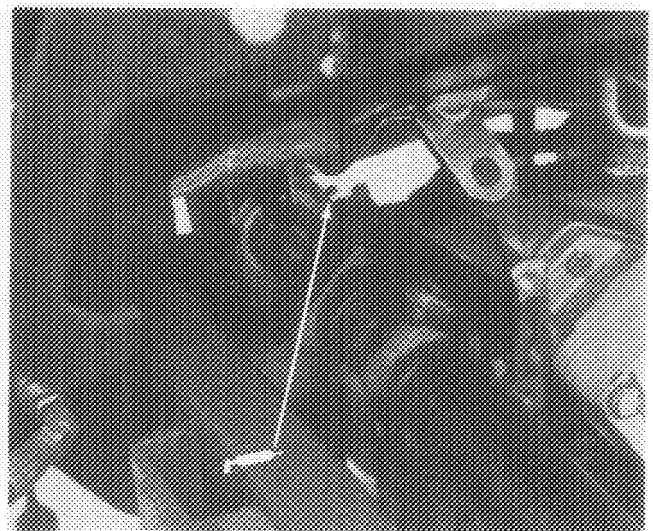

Figure 27

# LUBRICATION

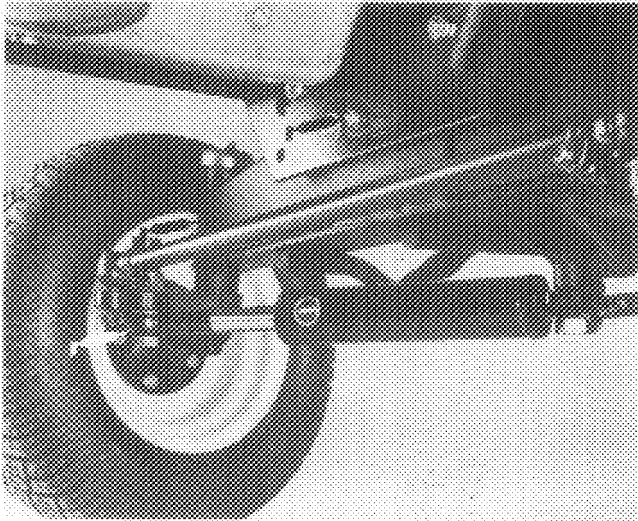

Figure 28

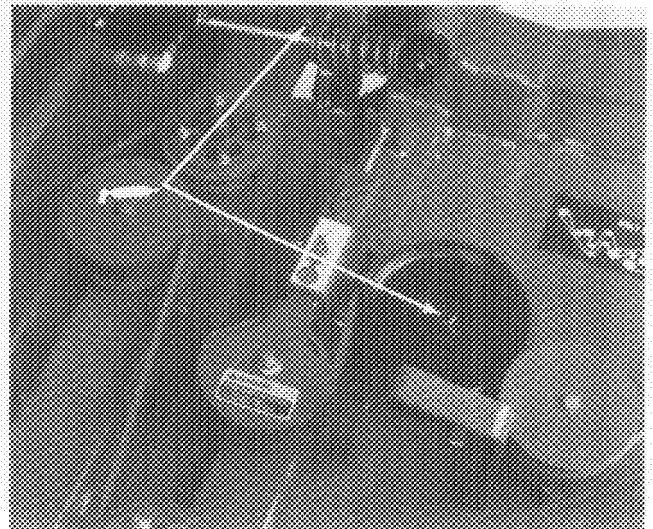

Figure 31

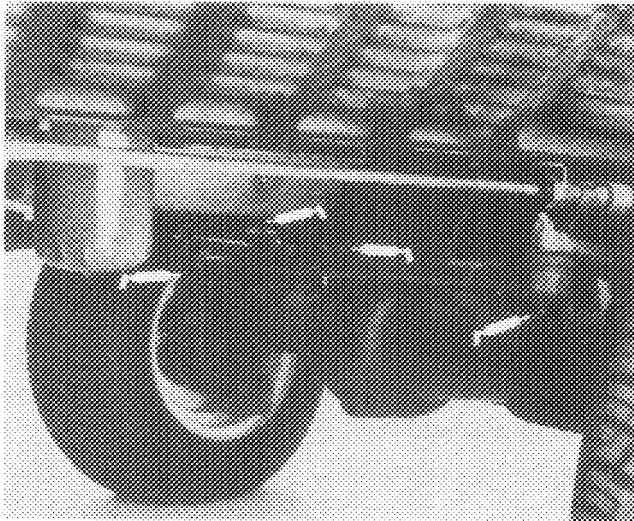

Figure 29

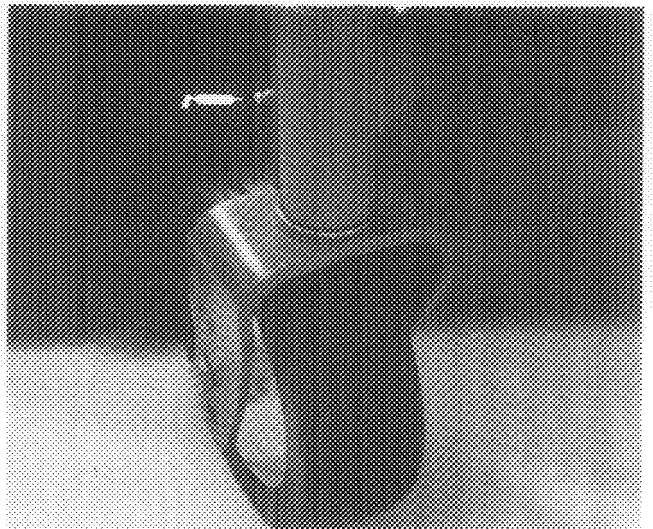

Figure 32

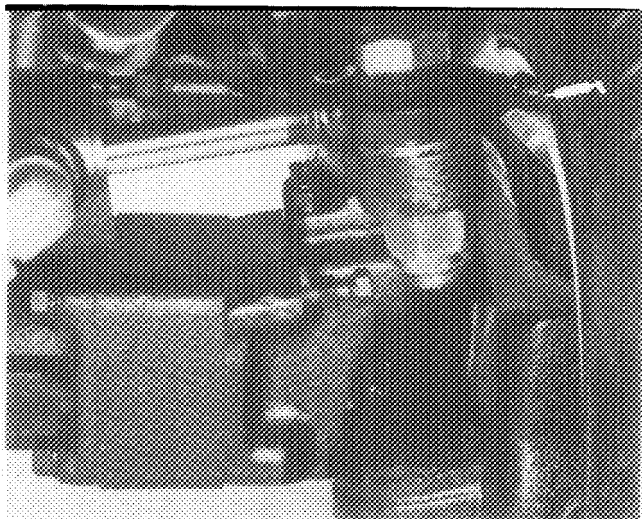

Figure 30

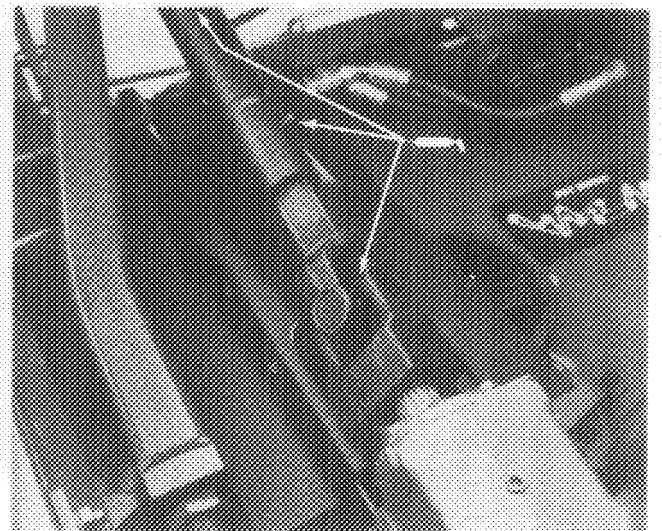

Figure 33

# AIR CLEANER MAINTENANCE



## CAUTION

Before servicing or making adjustments to the machine, stop engine and remove key from the switch.

## GENERAL MAINTENANCE PRACTICES

Inspect air cleaner and hose periodically to maintain maximum engine protection and to ensure maximum service life.

1. Assure hose between air cleaner and intake manifold is clamped securely in place. Replace the hose if it is cracked or punctured.
2. Check air cleaner body for dents and other damage which could possibly cause an air leak. Replace a damaged air cleaner body.
3. Be sure dust cup is sealing around air cleaner body.
4. Mounting screws and nuts holding air cleaner in place must be tight.
5. Inlet screen on rear of hood must be free of obstruction.

## SERVICING DUST CUP AND BAFFLE (Fig. 34)

Inspect the dust cup and rubber baffle once a week or every 50 hours operation. However, daily or more frequent inspection is required when operating conditions are extremely dusty and dirty.

**Note:** If conditions are extremely dusty and dirty, begin by checking dust cup and baffle after each day's operation to establish approximately how long an interval passes before dust cup should be emptied. Base further maintenance requirements on this figure. These conditions may be particularly prevalent if the rear discharge cutting unit is attached.

1. Loosen thumb screw until dust cup and baffle can be removed. Separate dust cup and baffle.
2. Dump dust out of the dust cup. After cleaning cup and baffle, assemble and reinstall both parts.

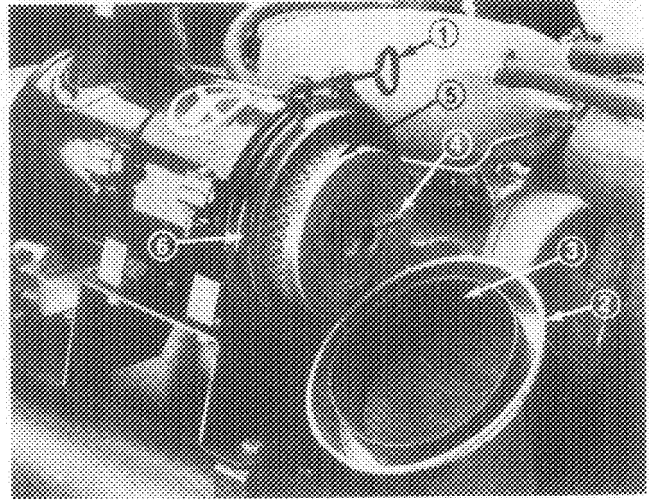

Figure 34

- |                |                      |
|----------------|----------------------|
| 1. Thumb Screw | 4. Wing Nut & Gasket |
| 2. Dust Cup    | 5. Filter Element    |
| 3. Baffle      | 6. Air Cleaner Body  |

## SERVICING AIR CLEANER FILTER (Fig. 34)

Service the air cleaner filter every 250 hours or more frequently in extreme dusty or dirty conditions by washing or using compressed air. Replace the element after every six cleanings (1500 hours) or annually, whichever comes first.

1. Remove and service dust cup; refer to Servicing Dust Cup and Baffle, page 22.
2. Remove wing nut w/gasket and slide filter element out of air cleaner body.
3. Clean the element by washing it in a solution of filter cleaner (Toro Part No. 27-7220) and water, or blow dirt out of filter by using compressed air.

**Note:** Compressed air is recommended when element must be used immediately after servicing because a washed element must be dried before it is used. By comparison, washing the element cleans better than blowing dirt out with compressed air. Remember, though, filter must be washed when exhaust soot is lodged in the filter pores.

### Washing Method

**IMPORTANT: Do not remove plastic fin assembly because washing removes dust from beneath fins.**

- A. Prepare a solution of filter cleaner and water and soak filter element about 15 minutes. Refer to directions on filter cleaner carton for complete information.
- B. After soaking filter for 15 minutes, rinse it with clear water. Maximum water pressure must not exceed 40 psi to prevent damage to the filter element.

# AIR CLEANER MAINTENANCE

C. Dry filter element using warm, flowing air (160°F max), or allow element to air-dry. Do not use compressed air or a light bulb to dry the filter element because damage could result.

## Compressed Air Method

**IMPORTANT: Do not remove plastic fin assembly because back-blowing with compressed air removes dust from beneath fins.**

A. Blow compressed air from inside to the outside of dry filter element. Do not exceed 100 psi to prevent damage to the element.

B. Keep air hose nozzle at least one inch from pleated paper, and move nozzle up and down while rotating the filter element. Inspect element

when dust and dirt are removed; refer to Inspecting Filter Element, page 23.

4. Wipe inside of air cleaner body with a damp cloth to remove excess dust. Slide filter into air cleaner body and secure it in place with wing nut and gasket.

5. Reinstall dust cup and baffle. Move thumb screw behind air cleaner body and tighten it securely.

## INSPECTING FILTER ELEMENT (Fig. 34)

1. Place bright light inside filter.

2. Rotate filter slowly while checking for cleanliness, ruptures, holes, and tears. Replace defective filter element.

3. Check fin assembly, gasket, and screen for damage. Replace filter if damage is evident.

# ENGINE MAINTENANCE



## CAUTION

Before servicing or making adjustments to the machine, stop engine and remove key from the switch.

## ENGINE OIL AND FILTER (Fig. 35–36)

Change oil and filter initially after the first 50 hours of operation, thereafter change oil every 50 hours and filter every 100 hours.

1. Remove drain plug (Fig. 35) and let oil flow into drain pan. When oil stops, install drain plug and new plug seal.

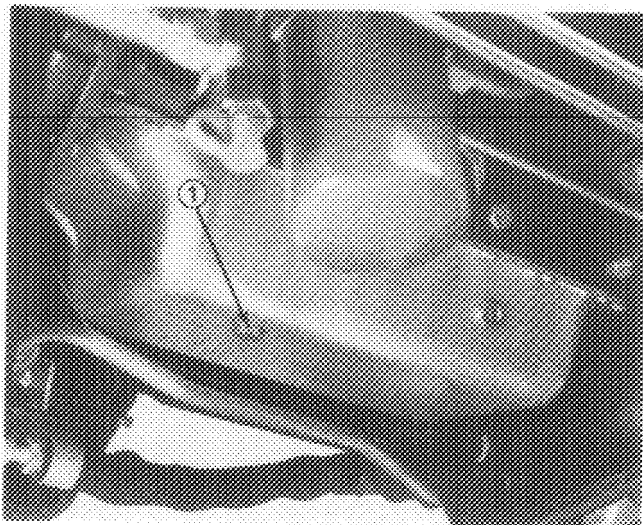

Figure 35  
1. Drain Plug

2. Remove oil filter (Fig. 36). Apply a light coat of clean oil to the new filter seal before screwing it on. DO NOT OVER-TIGHTEN.

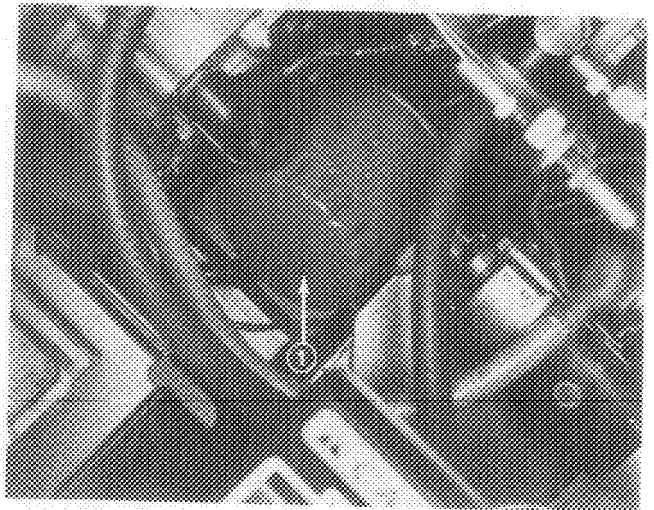

Figure 36  
1. Oil Filter

3. Add oil to crankcase. Capacity is 5.3 quarts with filter.

## FUEL SYSTEM (Fig. 37)

### Fuel Tank

Drain and clean fuel tank every 400 hours of operation or yearly, whichever comes first. Also, drain and clean tank if fuel system becomes contaminated or if machine is to be stored for an extended period. Use clean fuel to flush out the tank.

# ENGINE MAINTENANCE



**DANGER**

Because diesel fuel is highly flammable, use caution when storing or handling it. Do not smoke while filling the fuel tank. Do not fill fuel tank while engine is running, hot, or when machine is in an enclosed area. Always fill fuel tank outside and wipe up any spilled diesel fuel before starting the engine. Store fuel in a clean, safety-approved container and keep cap in place. Use diesel fuel for the engine only; not for any other purpose.

## Fuel Lines and Connections

Check lines and connections every 400 hours or yearly, whichever comes first. Inspect for deterioration, damage, or loose connections.

## Draining Fuel Filter / Water Separator

Drain water or other contaminants from fuel filter / water separator daily.

1. Place a clean container under fuel filter.

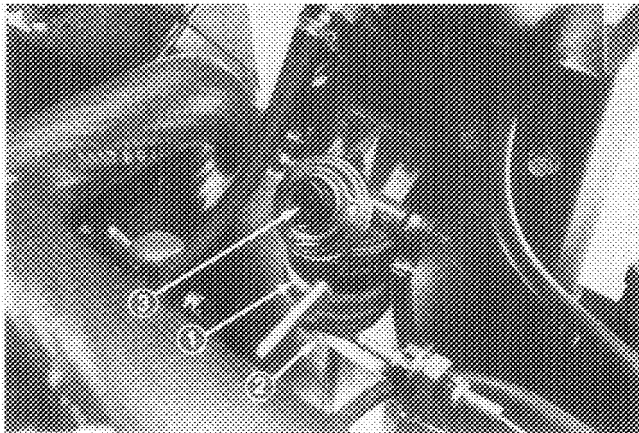

Figure 37.

1. Fuel Filter / Water Separator
2. Drain Screw
3. Primer Plunger

2. Loosen drain screw on bottom of fuel filter and press primer plunger until only fuel is evident draining into container.

3. Tighten drain screw.

## Changing Fuel Filter

Replace fuel filter if fuel flow becomes restricted, after every 400 hours of operation or annually, whichever comes first.

1. Unscrew bottom filter cap from filter assembly. Remove cap, gaskets, o-ring and filter from assembly. Note position of gaskets and o-ring when disassembling from filter.

3. Install new filter, gaskets, o-ring with filter assembly cap.

4. Prime fuel system, refer to Priming Fuel System, page 17.

## ENGINE COOLING SYSTEM (Fig. 38–39)

1. **Removing Debris** – Remove debris from rear screen, oil cooler and radiator daily, clean more frequently in dirty conditions.

- A. Turn engine off, release hood latch and raise hood. Clean engine area thoroughly of all debris. Close hood.

- B. Unscrew knobs and remove rear screen (Fig. 38). Clean screen thoroughly.

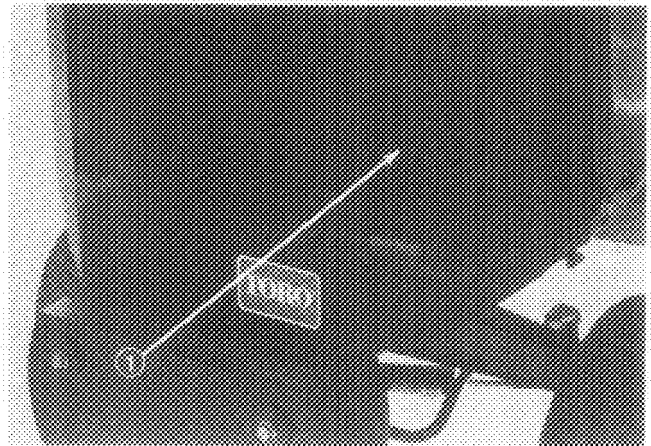

Figure 38  
1. Rear Screen

- C. Unscrew knobs and pivot oil cooler rearward. Clean both sides of oil cooler and radiator area thoroughly with compressed air. Open hood and blow debris out toward back of machine. Pivot oil cooler back into position and tighten knobs.

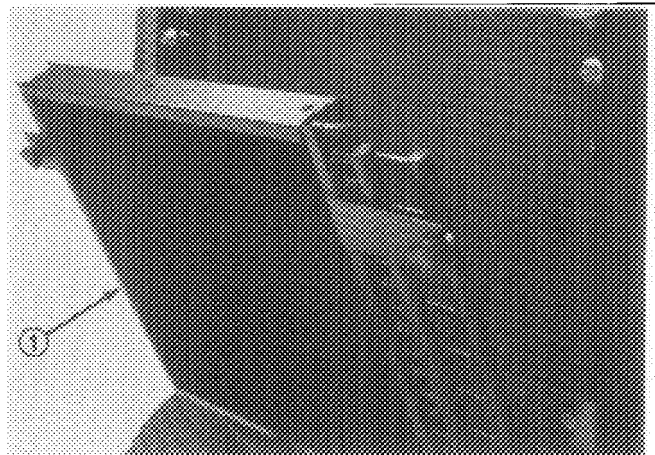

Figure 39  
1. Oil Cooler



# ENGINE MAINTENANCE

**Note:** Upper portion of fan shroud may be easily unbolted from machine to simplify cleaning.

D. Install rear screen and tighten knobs.

**Note:** Do not use water to clean engine, as damage may occur.

**2. Maintaining Cooling System** – Capacity of the system is 3.5 gal. Always protect cooling system with a 50/50 solution of water and Peugeot recommended anti-freeze. **DO NOT USE WATER ONLY IN COOLING SYSTEM.**

A. After every 100 operating hours, tighten hose connections. Replace any deteriorated hoses.

B. After every 2 years, drain and flush the cooling system. Add anti-freeze (refer to Check Cooling System, Page 11).

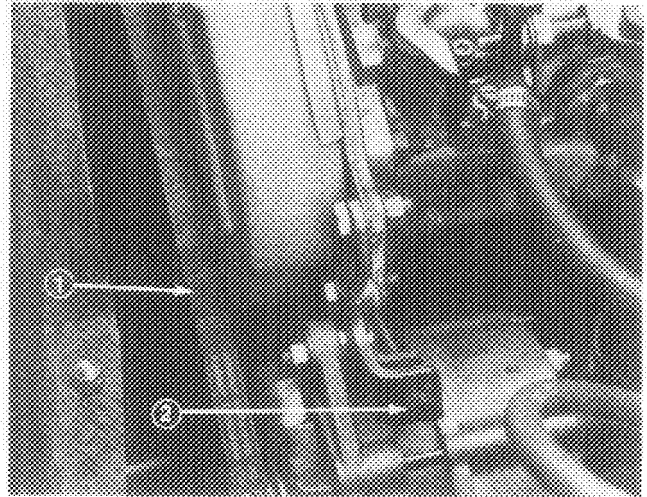

**Figure 40**

1. Fan Belt 2. Adjusting Screw

## ENGINE FAN BELT (Fig. 40)

Check condition and tension of fan belt (Fig. 40) frequently. It is recommended that belt be replaced after every 800 hours of operation.

1. Proper tension will allow 1/4 in. deflection on the belt midway between the pulleys, when pressed firmly with thumb.

2. If deflection exceeds 1/4 in., loosen alternator mounting bolts. Adjust alternator belt tension by adjusting tension screw. Check deflection of belt again to assure tension is correct.

# HYDRAULIC MAINTENANCE

	<b>CAUTION</b>
<b>Before servicing or making adjustments to the machine, stop engine and remove key from the switch.</b>	

## CHANGING HYDRAULIC OIL (Fig. 41 & 42)

Normally, change hydraulic oil after every 500 operating hours. If oil becomes contaminated, contact your local TORO distributor because the system must be flushed. Contaminated oil looks milky or black when compared to clean oil.

1. Turn engine off, release hood latch and raise hood.
2. Remove drain plug from rear of reservoir and hydraulic line from front of reservoir (Fig. 41) and let hydraulic oil flow into drain pan. Reinstall and tighten plug and line when hydraulic oil stops draining.
3. Fill reservoir with approximately 6.5 gallons of hydraulic oil. Refer to Check Hydraulic Circuit Oil, page 11.

**IMPORTANT:** Use only hydraulic oils specified. Other fluids could cause system damage.

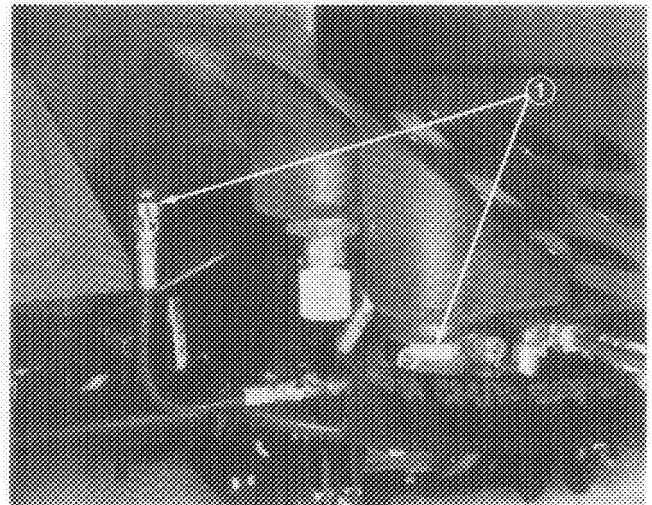

**Figure 41**

1. Hydraulic Reservoir Drain

4. Install reservoir cap, lower hood and latch. Start engine and use all hydraulic controls to distribute hydraulic oil throughout the system. Also check for leaks. Then stop the engine.

5. With cutting decks raised and oil warm, look into sight gauge (Fig. 42). If hydraulic oil is not visible, add enough oil to raise level to middle (maximum) of sight gauge. To prevent over filling, do not fill if oil is cold. **DO NOT OVER FILL.**

# HYDRAULIC MAINTENANCE

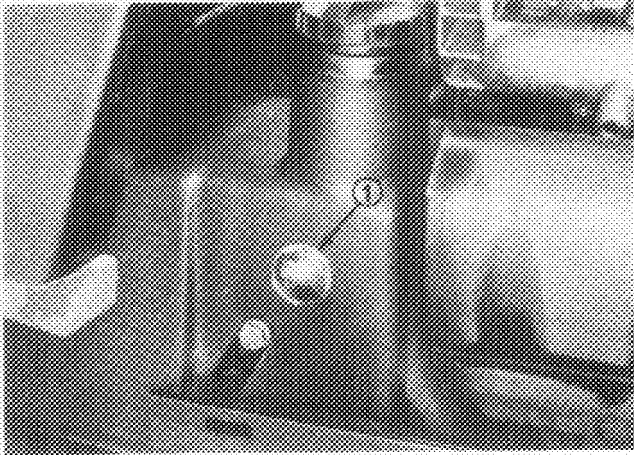

**Figure 42**  
1. Sight Gauge

## REPLACING HYDRAULIC FILTER (Fig. 43)

Initially, change filter after the first 50 operating hours, thereafter, every 500 operating hours or annually, whichever comes first.

Only the Toro replacement filter (Part No.86-3010) can be used in the hydraulic system.

**IMPORTANT: Using other filters may void the warranty, and could cause component failure or premature wear.**

1. Turn engine off, release hood latch and raise hood.
2. Clean area around filter mounting area (Fig. 43). Place drain pan under filter and remove filter.

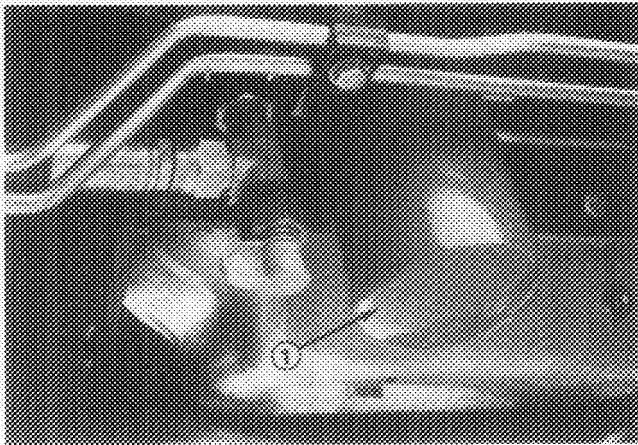

**Figure 43**  
1. Hydraulic Filter

3. Lubricate new filter gasket and fill the filter with hydraulic oil.
4. Assure filter mounting area is clean. Screw filter on until gasket contacts mounting plate. Then tighten filter one-half turn.
5. Start engine and let run for about two minutes to purge air from the system. Stop the engine and check oil level. Also check for any leaks.

## CHECKING HYDRAULIC LINES AND HOSES

After every 100 operating hours, check hydraulic lines and hoses for leaks, kinked lines, loose mounting supports, wear, loose fittings, weather deterioration and chemical deterioration. Make all necessary repairs before operating.



### WARNING

Keep body and hands away from pin hole leaks or nozzles that eject high pressure hydraulic fluid. Use cardboard or paper to find hydraulic leaks. Hydraulic fluid escaping under pressure can penetrate skin and cause injury. Fluid accidentally injected into the skin must be surgically removed within a few hours by a doctor familiar with this form of injury or gangrene may result.

## HYDRAULIC SYSTEM TEST PORTS

(Fig. 44 & 47)

The test ports are used to test the hydraulic circuits. Check all pressures when engine is at full speed and hydraulic oil is at normal operating temperature. Contact your local Toro distributor for assistance.

1. Traction Forward and Reverse have a normal relief setting of approximately 6000 psi.
2. Normal charge pressure is 110 psi.

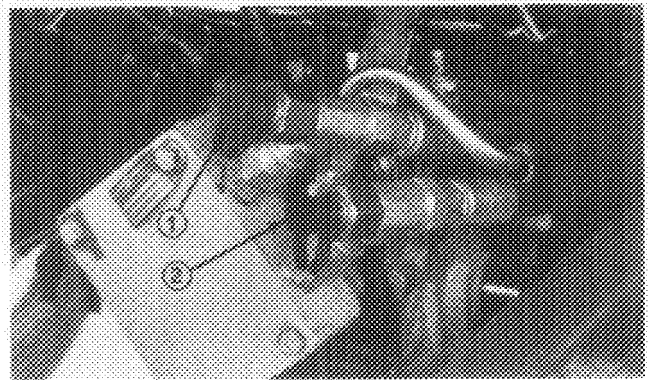

**Figure 44**

1. Traction Forward Circuit
2. Traction Reverse Circuit

3. Cutting unit Counterbalance normal setting is approximately 600-650 psi @ high Idle and when oil is warm.
4. Lift circuit relief pressure is approximately 2150-2300 psi when oil is warm.
5. Steering Circuit has a normal relief setting of approximately 1200 psi @ high idle and warm oil.

# HYDRAULIC MAINTENANCE

6. Wing deck cutting unit Counterbalance normal setting is approximately 350–400 psi @ high Idle and when oil is warm.

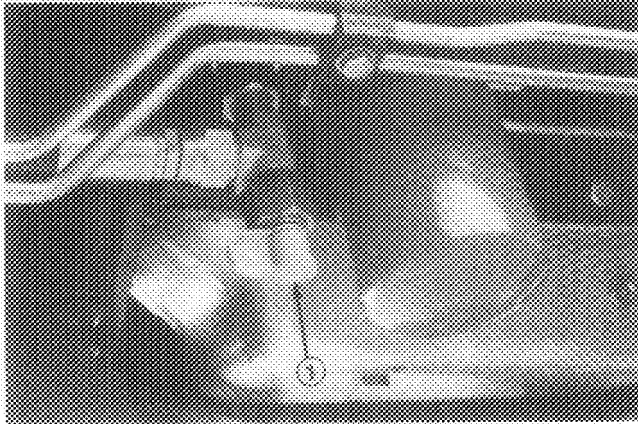

Figure 45  
1. Charge Pressure

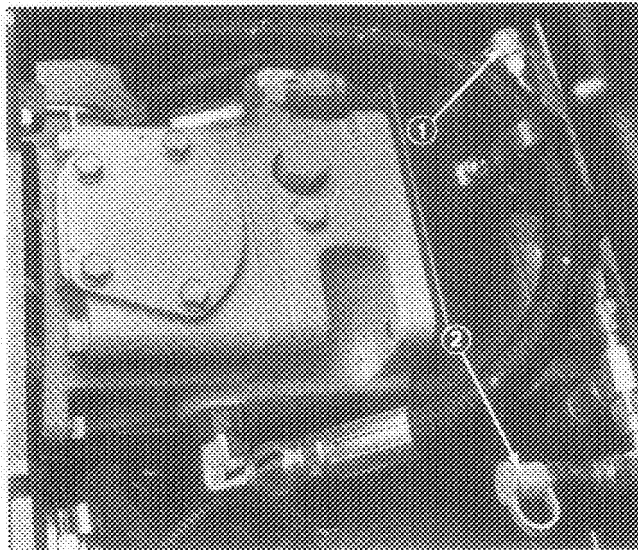

Figure 46  
1. Counterbalance/Lift Circuit  
2. Steering Circuit

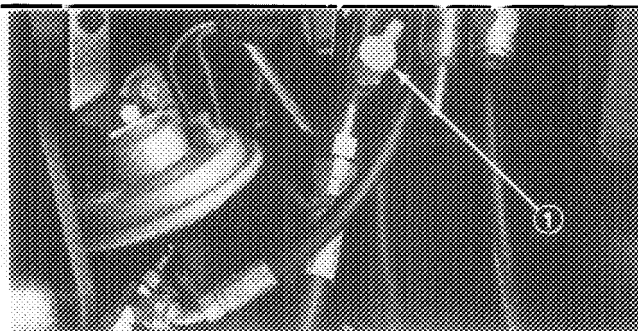

Figure 47  
1. Counterbalance (Wing Decks)

## ADJUSTING TRACTION DRIVE FOR NEUTRAL (Fig. 48)

The machine must not creep when traction pedal is released. If it does creep, an adjustment is required.

1. Park machine on a level surface, shut engine off and move shift lever to "HI" position. Depress only the left brake pedal and engage the parking brake.
2. Jack up right side of machine until front tire is off the shop floor. Support machine with jack stands to prevent it from falling accidentally.
3. Under left side of machine, loosen locknut on traction adjustment cam.

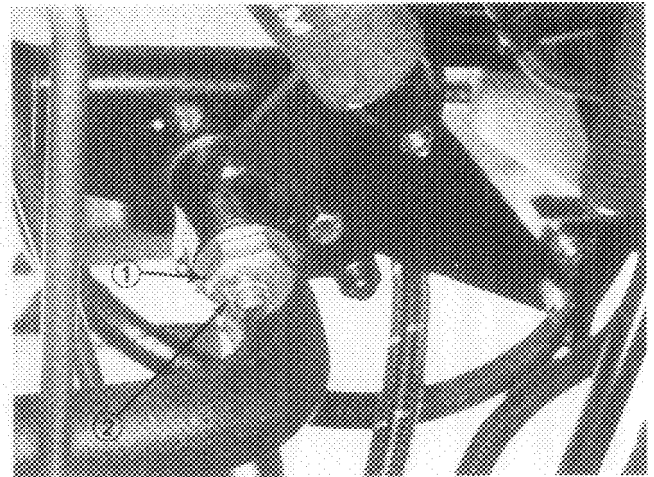

Figure 48  
1. Traction Adjustment Cam  
2. Locknut

4. Start engine and rotate cam hex in either direction until wheel ceases rotation.



### WARNING

Engine must be running so final adjustment of the traction adjustment cam can be performed. To guard against possible personal injury, keep hands, feet, face and other parts of the body away from the muffler, other hot parts of the engine, and other rotating parts.

5. Tighten locknut locking adjustment.
6. Stop the engine and release the right brake. Remove jack stands and lower the machine to the shop floor. Test drive the machine to make sure it does not creep.

# HYDRAULIC SCHEMATICS

## 2 WHEEL DRIVE

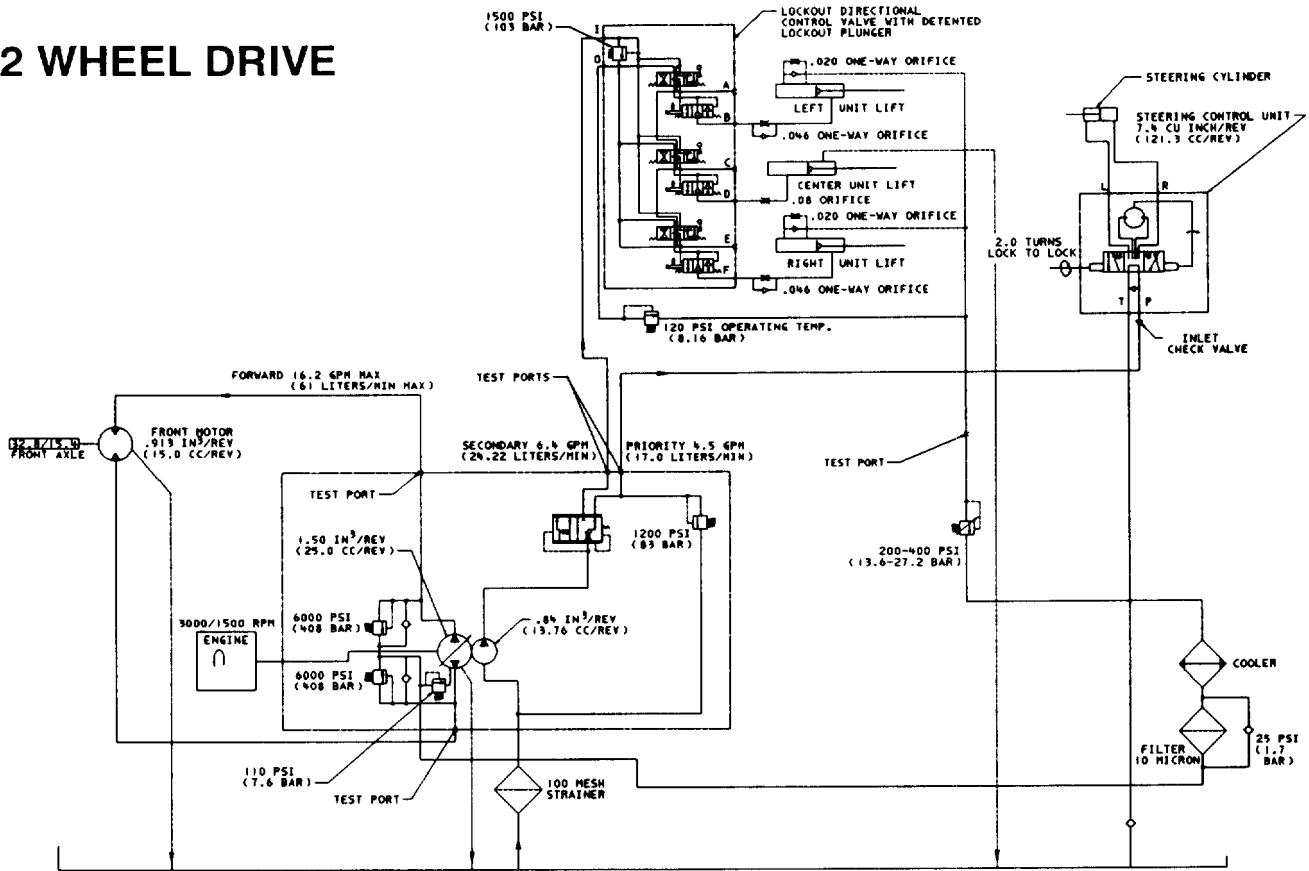

## 4 WHEEL DRIVE

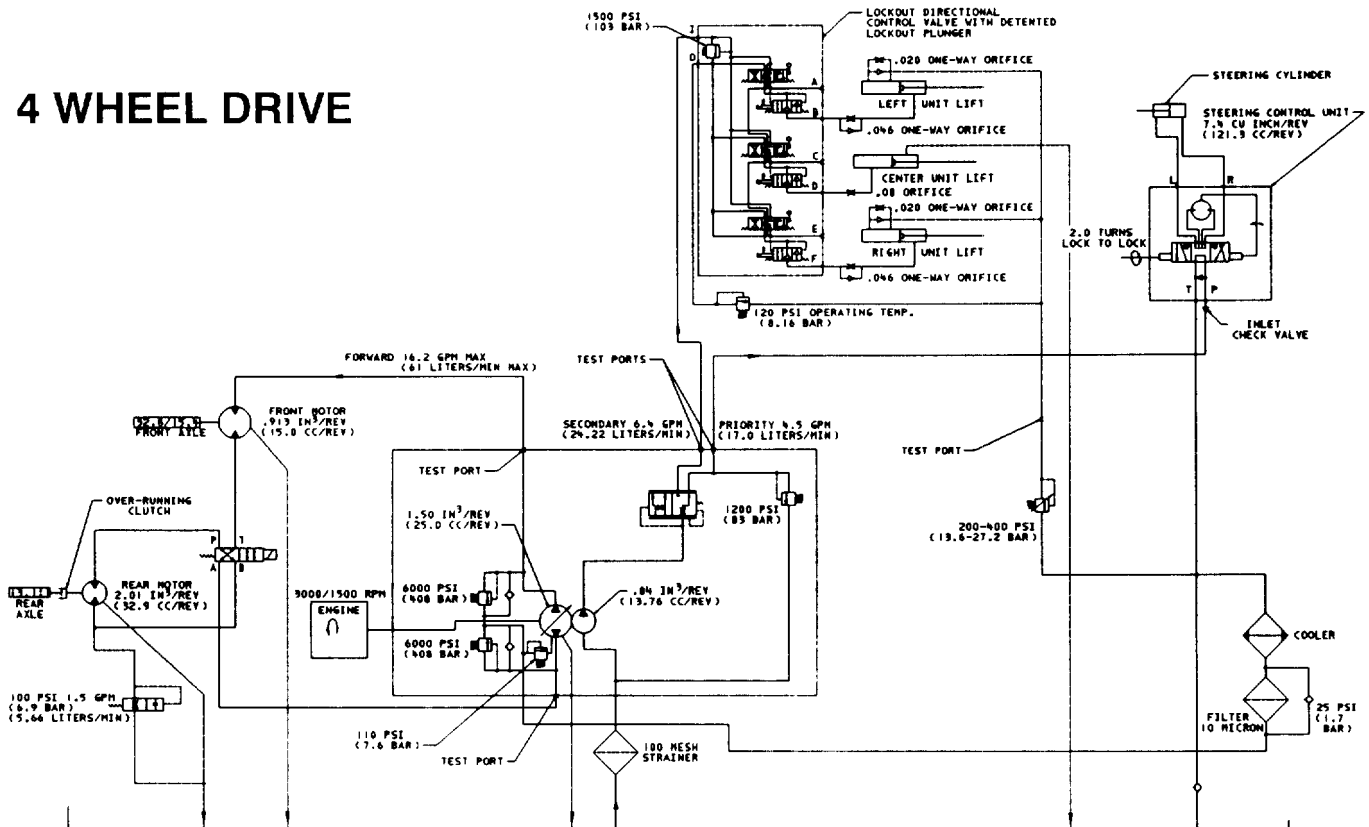

# AXLE MAINTENANCE



## CAUTION

Before servicing or making adjustments to the machine, stop engine and remove key from the switch.

### CHANGING FRONT AXLE LUBRICANT

(Fig. 49)

After every 500 hours of operation the oil in the front axle must be changed.

1. Position machine on a level surface.
2. Clean area around the drain plug (Fig. 49).

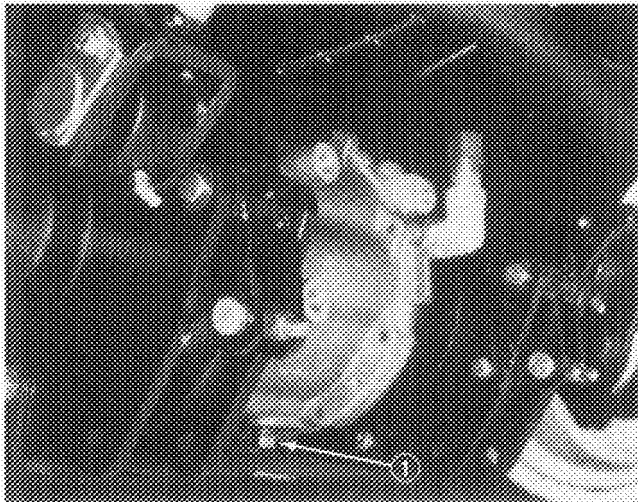

Figure 49

1. Front Axle Drain Plug

3. Remove plug allowing oil to drain into drain pans.
4. After oil is drained, reinstall drain plug into axle.
5. Fill axle with lubricant; refer to Check Front Axle Oil Level, page 12.

### CHANGING REAR AXLE LUBRICANT (Model 30455 only) (Fig. 50)

After every 500 hours of operation the oil in the rear axle must be changed.

1. Position machine on a level surface.
2. Clean area around the (3) drain plugs, (1) on each end and (1) in the center (Fig. 50).

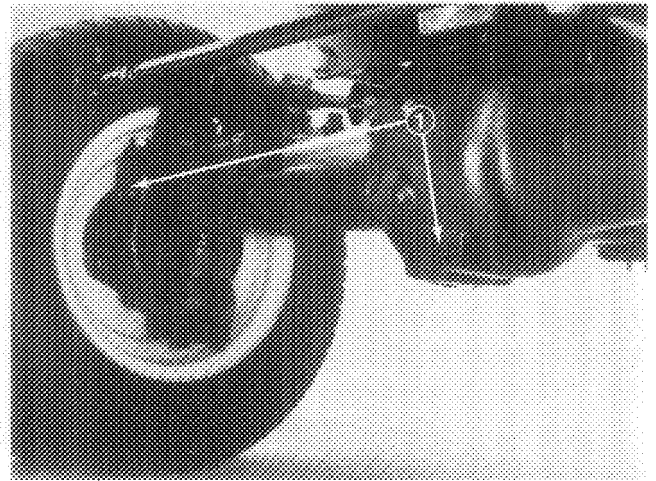

Figure 50

1. Drain Plugs (3)

3. Remove plugs allowing oil to drain into drain pans.
4. After oil is drained, apply thread sealing compound on drain plug threads and reinstall in axle.
5. Fill axle with lubricant; refer to Check Rear Axle Lubricant, page 12.

### REAR WHEEL TOE-IN (Fig. 51)

After every 800 operating hours or annually, check rear wheel toe-in.

1. Measure center-to-center distance (at axle height) at front and rear of steering tires. Front measurement must be 1/4 in. less than rear measurement.
2. To adjust, loosen clamps at both ends of tie rods.

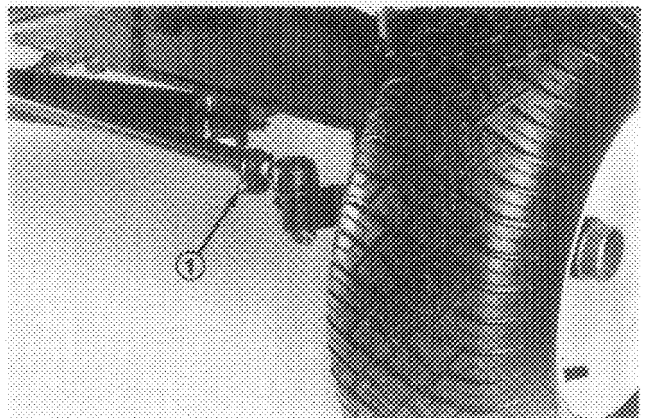

Figure 51

1. Tie Rod Clamps

3. Rotate tie rod to move front of tire inward or outward.
4. Tighten tie rod clamps when adjustment is correct.

# BRAKE MAINTENANCE

## ADJUSTING SERVICE BRAKES (Fig. 52)

Adjust the service brakes when there is more than 1–1/2" of "free travel" of the brake pedal, or when the brakes do not work effectively. Free travel is the distance the brake pedal moves before braking resistance is felt.

1. To reduce free travel of brake pedals, tighten nut on brake rod adjuster, 1/2 turn at a time, until desired "free play" in pedal is achieved.

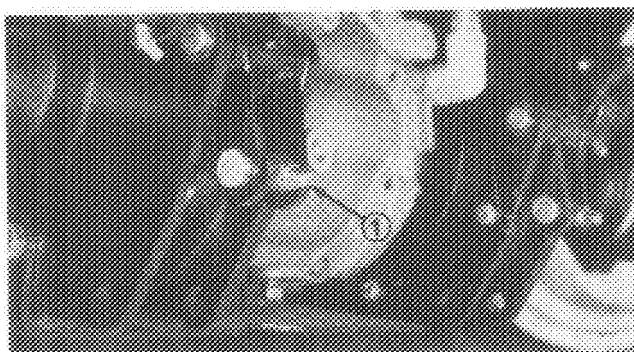

Figure 52  
1. Brake Rod Adjuster

# P.T.O. MAINTENANCE



## CAUTION

Before servicing or making adjustments to the machine, stop engine and remove key from the switch.

## ADJUSTING P.T.O. BELT (Fig. 53–54)

Check condition and tension of P.T.O. belt (Fig. 54) frequently. It is recommended that belt be replaced after every 1500 hours of operation.

1. Remove (2) screws securing P.T.O. belt cover to adapter plate and (1) screw securing belt cover to tab on spring anchor. Remove cover.

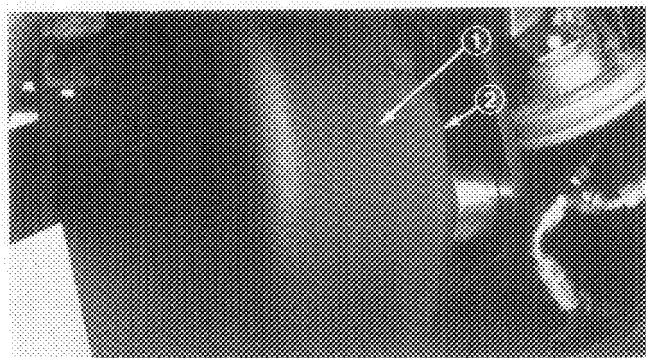

Figure 53  
1. P.T.O. Belt Cover  
2. Adapter Plate

2. Loosen (3) flange screws and flange nuts securing adapter plate to clutch plate.
3. Insert end of 1/2 drive, 20" long, torque wrench into square hole in clutch plate. With wrench handle parallel to ground, pull wrench upward until 180 ft–lbs. of torque is applied to tension belt.
4. Tighten flange screws and flange nuts locking adjustment.
5. Reinstall P.T.O. belt cover with screws previously removed.

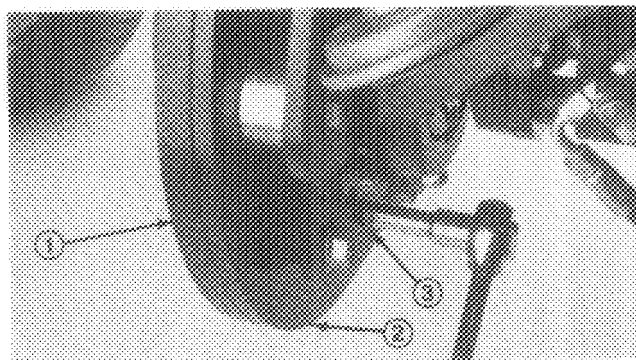

Figure 54  
1. P.T.O. Belt 2. Adapter Plate 3. Square hole

## ADJUSTING CLUTCH (Fig. 55)

The P.T.O. clutch is adjustable to ensure proper engagement and blade braking. Check clutch adjustment after every 250 hours of operation and adjust if required.

1. To adjust clutch, tighten or loosen locknuts on flange studs.
2. Check adjustment by inserting feeler gauge thru slots next to flange studs.
3. The proper disengaged clearance between the clutch plates is .011 – .021 inches. It will be necessary to check this clearance at each of the three slots to ensure the plates are parallel to each other.

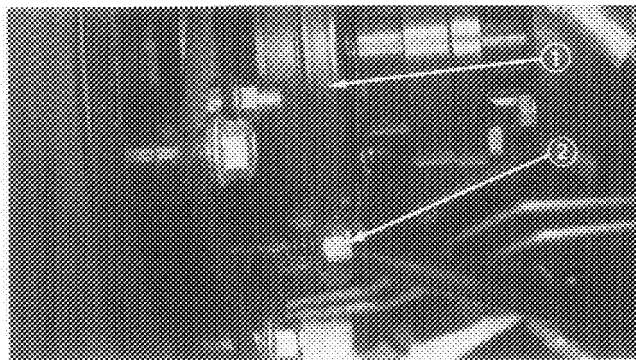



Figure 55  
1. Clutch  
2. Flange studs

# ELECTRICAL MAINTENANCE



## CAUTION

**Before servicing or making adjustments to the machine, stop engine and remove key from the switch.**

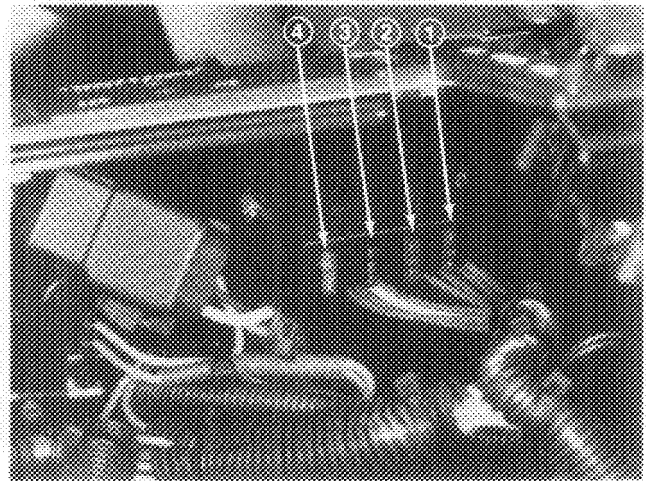

**Figure 56**

- 1. ACC Fuse
- 2. Relay Fuse
- 3. Deck Fuse
- 4. Run Fuse

## BATTERY CARE

**IMPORTANT:** Before welding on the machine, disconnect ground cable from the battery to prevent damage to the electrical system.

**Note:** Check battery condition weekly or after every 50 hours of operation. Keep terminals and entire battery case clean because a dirty battery will discharge slowly. To clean the battery, wash the entire case with solution of baking soda and water. Rinse with clear water. Coat the battery posts and cable connectors with Grafo 112X (skin-over) grease (Toro Part No. 505-47) or petroleum jelly to prevent corrosion.

## FUSES (Fig. 56)

There are 4 fuses in the machines electrical system. They are located inside control panel.

FUSES	
ACC	5A
RELAY	5A
DECK	30A
RUN	15A

## ELECTRICAL SCHEMATIC

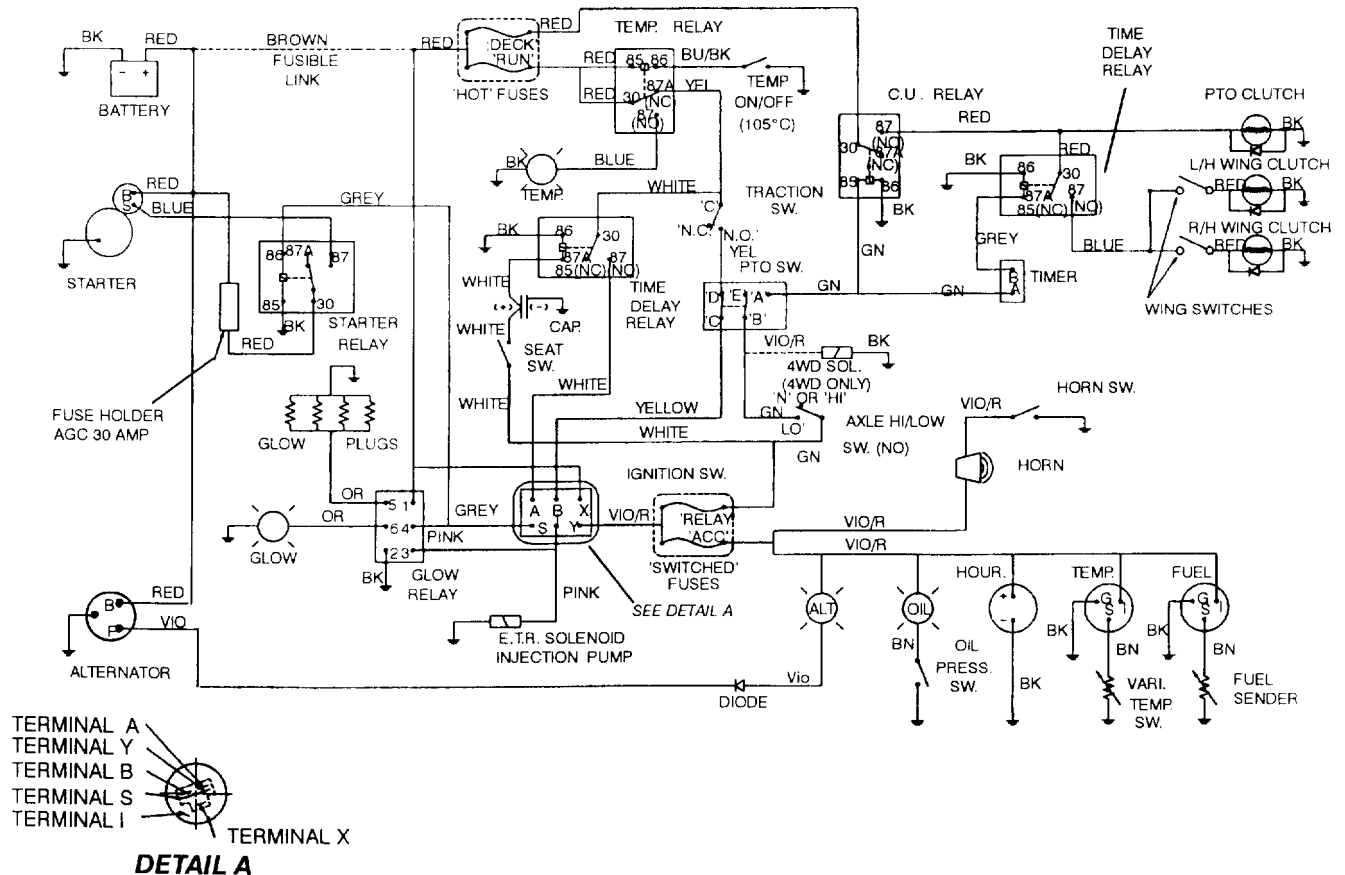

# CUTTING UNIT MAINTENANCE



## CAUTION

To prevent accidental starting of the engine, while performing maintenance, shut engine off and remove key from ignition switch.

## GENERAL MAINTENANCE

**Note:** Although not required for normal maintenance procedures, the cutting unit may be pivoted (tilted) to a upright position. Should you desire to tilt the cutting unit, use the following procedure:

### To Pivot (Tilt) Cutting Unit Upright:

1. Lower center and wing cutting units to the ground: then raise center cutting unit slightly, until rear deck straps hang freely on lift arm brackets. Stop engine after cutting unit is raised. Set parking brake.
2. Disconnect (3) hydraulic lines (quick couplers) and wire harness at rear of deck (Fig. 57).

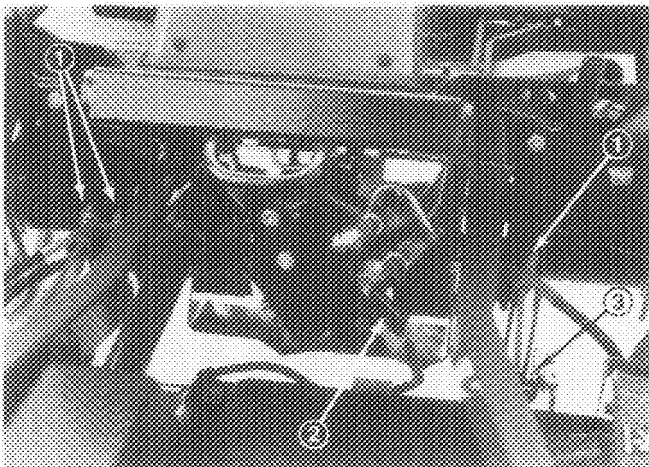

Figure 57

1. Hydraulic Line Couplers
2. Wire Harness
3. Rear Deck Straps

3. Remove hairpin cotters and H.O.C. pins securing rear deck straps to H.O.C. brackets on deck (Fig. 57).
4. Remove socket head screw securing drive shaft yoke gear box input shaft. Slide yoke off shaft (Fig. 58).



## DANGER

Do not start the engine and engage the PTO switch when PTO shaft is not connected to gear box on cutting unit. If engine is started and PTO shaft is allowed to rotate, serious injury could result.

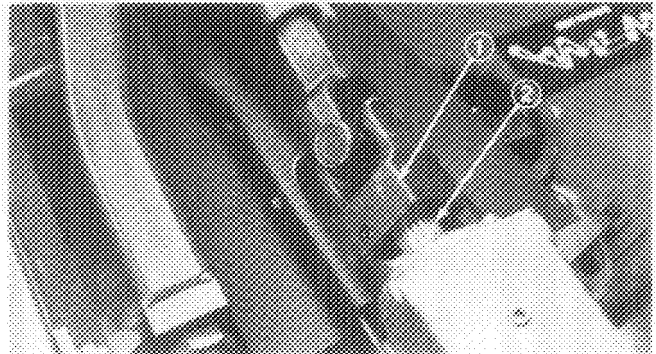

Figure 58

1. Drive Shaft Yoke
2. Gear Box Input Shaft

5. Sit on seat, start the engine and slowly raise the cutting unit allowing cutting unit to pivot upright. Stop the engine and remove the key from the ignition switch.

### To Pivot Cutting Unit down into Operating Position:

1. Sit on seat, start the engine and slowly lower the cutting units to the ground: then raise center cutting unit slightly, so rear deck straps can be mounted to lift arm brackets. Stop engine after cutting unit is raised. Set parking brake.
2. Line up holes in yoke and input shaft of gear box. Slide yoke onto shaft and secure together with socket head screws. Torque screws to 20–25 ft–lb.
3. Secure rear deck straps to H.O.C. brackets on deck with hair pin cotters and H.O.C. pins. Lower center cutting unit completely to floor.
4. Connect wire harness and (3) hydraulic lines couplers at rear of deck.

## SEPARATING CUTTING UNIT FROM TRACTION UNIT (Fig. 59–60)

1. Lower center and wing cutting units to the ground: then raise center cutting unit slightly, until rear deck straps hang freely on lift arm brackets. Stop engine after cutting unit is raised. Set parking brake.
2. Remove hairpin cotters and H.O.C. pins securing rear deck straps to H.O.C. brackets on deck. Lower center cutting unit completely to floor.
3. Disconnect (3) hydraulic lines (quick couplers) and wire harness at rear of deck.
4. Remove socket head screw securing drive shaft yoke gear box input shaft. Slide yoke off shaft.



## DANGER

Do not start the engine and engage the PTO switch when PTO shaft is not connected to gear box on cutting unit. If engine is started and PTO shaft is allowed to rotate, serious injury could result.



# CUTTING UNIT MAINTENANCE

- Remove (2) capscrews, flatwashers and flange nuts securing ball joint mounts to castor arms on cutting unit.

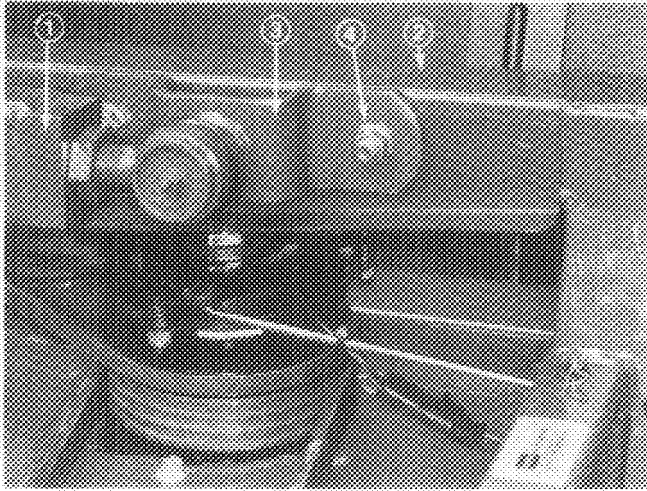

**Figure 59**

- |               |                        |
|---------------|------------------------|
| 1. Push Arm   | 3. Ball Joint Mount    |
| 2. Castor Arm | 4. Capscrews & Washers |

- Roll the cutting unit away from the traction unit.

## Alternate Method

- Lower cutting unit to the ground, set parking brake and stop engine.
- Disconnect (3) hydraulic lines (quick couplers) and wire harness at rear of deck.
- Remove socket head screw securing drive shaft yoke gear box input shaft. Slide yoke off shaft.
- Remove (2) capscrews and locknuts securing cutting unit carrier frames to traction unit lift arms (Fig. 60).

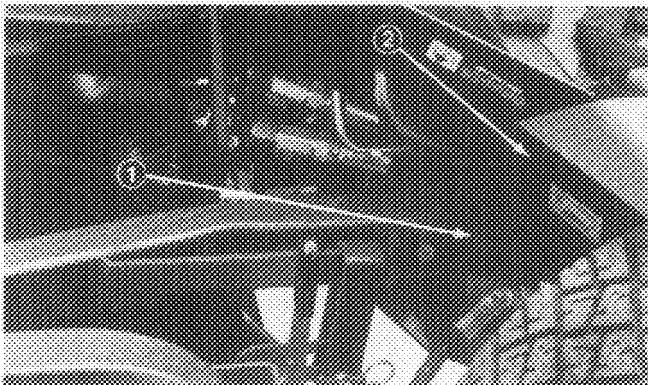

**Figure 60**

- |                                |
|--------------------------------|
| 1. Cutting Unit Carrier Frames |
| 2. Traction Unit Lift Arms     |

- Slowly back traction unit away from cutting unit.

## MOUNTING CUTTING UNIT TO TRACTION UNIT (Fig. 59–60)

- With cutting unit on a level surface, move traction unit into position in front of traction unit, aligning drive shaft yoke with gear box input shaft and lift arm ball joints with mounting holes in castor arms. Shut engine off.
- Secure ball joint mounts to castor arms with capscrews, flatwashers and flange nuts. Flatwashers to be positioned to outside of castor arm.
- Line up holes in yoke and input shaft of gear box. Slide yoke onto shaft and secure together with socket head screws. Torque screws to 20–25 ft–lb.
- Start engine, raise center cutting unit slightly, so rear deck straps can be mounted on lift arm brackets. Stop engine after cutting unit is raised.
- Secure rear deck straps to H.O.C. brackets on deck with hair pin cotters and H.O.C. pins. Lower center cutting unit completely to floor.
- Connect wire harness and (3) hydraulic lines couplers at rear of deck.

## SAFETY DOOR ADJUSTMENT (Fig. 61)

On each side of the center deck is a safety door that opens and closes as the wing decks are lowered and raised (Fig. 61). The doors open to provide overlap of the cutting blades when the wing units are down. The doors close to provide safety and protection when the wing units are raised. Check to make sure the forward, lower edge of door (Fig. 61) is even or 1/4" higher than lower edge of door guide when wing decks are in the fully raised, transport position. If an adjustment to the door is required, proceed as follows:

- Loosen jam nuts securing ball joints to threaded rod.

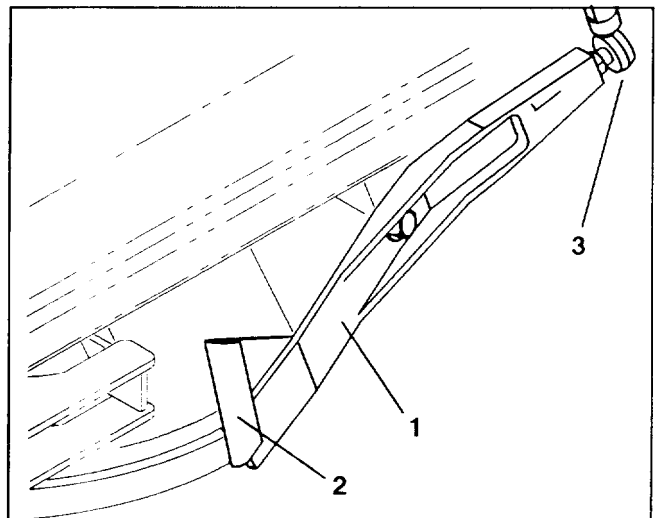
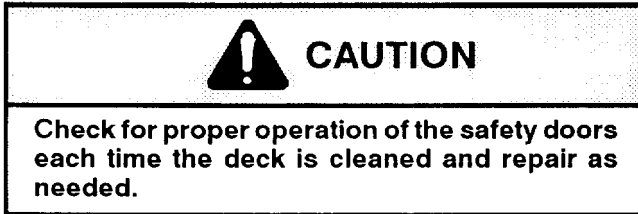

**Figure 61**

- |                |
|----------------|
| 1. Safety Door |
| 2. Door Guide  |
| 3. Ball Joint  |

# CUTTING UNIT MAINTENANCE

2. Rotate threaded rod to raise or lower edge of door until is even or 1/4" higher than lower edge of door guide when wing decks are in the fully raised, transport position.
3. Tighten jams nuts to lock adjustment.



## BLADE ADJUSTMENT (Fig. 62–63)

To assure proper operation of the cutting unit, there must be  $.25 \pm .12$ " clearance between the tips of the wing and center cutting unit blades.

1. Raise cutting unit so blades are visible and block center deck section so it cannot fall accidentally. Wing decks must be horizontal to center cutting unit.
2. Rotate a center and adjoining wing blade so there blade tips are aligned. Measure distance between blade tips, distance should be approximately  $.25 \pm .12$ .

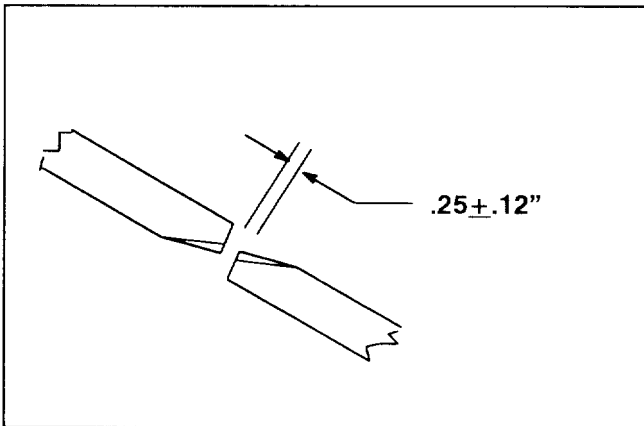

Figure 62

3. To adjust distance, locate adjuster bolt on rear outside corner of center cutting unit. Loosen jam nut on adjuster bolt. Loosen or tighten adjuster bolts until  $.25 \pm .12$  clearance is attained, then tighten jam nut.
4. Repeat procedure on opposite side of cutting deck.

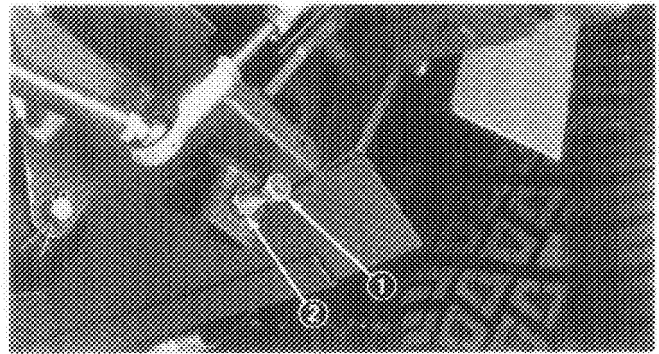

Figure 63  
1. Adjuster Bolt  
2. Jam Nut

**IMPORTANT: Blade plane is adjusted at the factory and should not need further adjustment.**

## ADJUSTING BELT TENSION (Fig. 64)

Each cutting unit drive belt is individually tensioned by a self tensioning spring loaded idler. When the idlers are properly adjusted, the black plastic sleeve should be flush (even) with the edge of the idler support. When 1/2" of the plastic sleeve is exposed, an adjustment is required. To assure proper operation of the cutting unit, check adjustment of spring loaded idler after first 10 hours of operation and every time maintenance on the belt is required.

1. Lower cutting unit to the shop floor. Remove belt covers from center and wing cutting units.
2. Measure the length of the exposed black plastic sleeve. If distance is 0 to 1/2", spring loaded idler is properly adjusted and belt tension is correct. If dimension is not correct, proceed to next step.

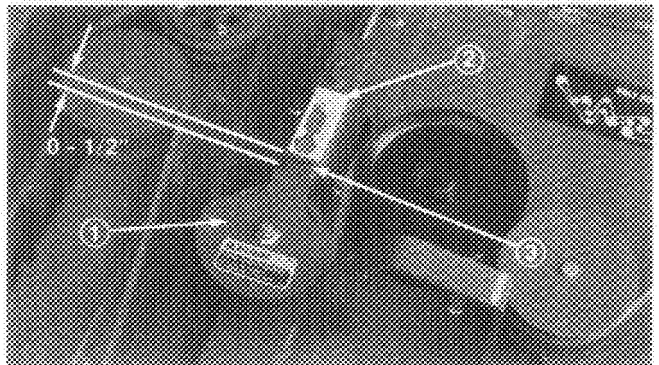

Figure 64

1. Spring Loaded Idler
2. Idler Support
3. Black, Plastic Sleeve

3. Loosen (2) flange head nuts securing idler adjustor tube to top of cutting deck.
4. Loosen jam nut on adjusting screw and rotate screw until the black plastic sleeve is flush (even) with the edge of idler support.
5. When distance is attained, tighten jam nut on adjusting screw and (2) flange head nuts securing idler adjustor tube to top of cutting deck.

# CUTTING UNIT MAINTENANCE

6. Check adjustment on other adjusters and repeat procedure if required.

## REPLACING DRIVE BELTS (Fig. 65– 68)

The blade drive belts are very durable, but after many hours of use, the belts will show signs of wear. Signs of a worn belt are: squealing when belt is rotating, blades slipping when cutting grass, frayed edges, burn marks and cracks. Replace a belt if any of these conditions are evident.

1. Lower cutting unit to the shop floor. Remove belt covers from center and wing cutting units.

### To Remove Wing Deck Belts

2. To relieve tension on wing belt, pull back on idler pulley until holes in idler adjuster tube and tube sleeve are aligned. Thread a 5/16–18 capscrew into holes retaining parts.

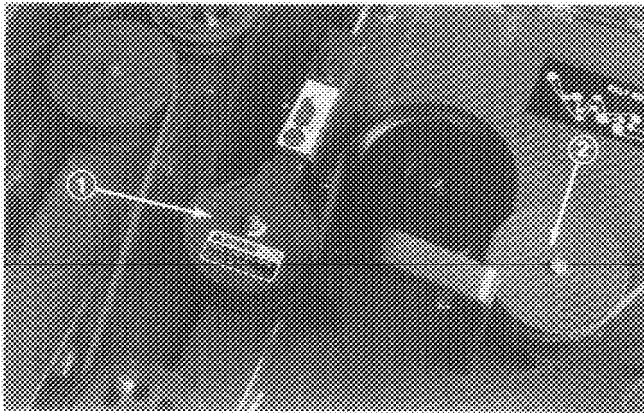

Figure 65

1. Spring Loaded Idler Pulley
2. Stationary Idler Pulley

3. Remove hair pin cotter securing clutch rod to front of cutting deck and disconnect rod from deck. Unplug clutch wire from harness.

4. To ease wing belt removal, loosen or remove stationary idler pulley next to wing's inner spindle pulley.

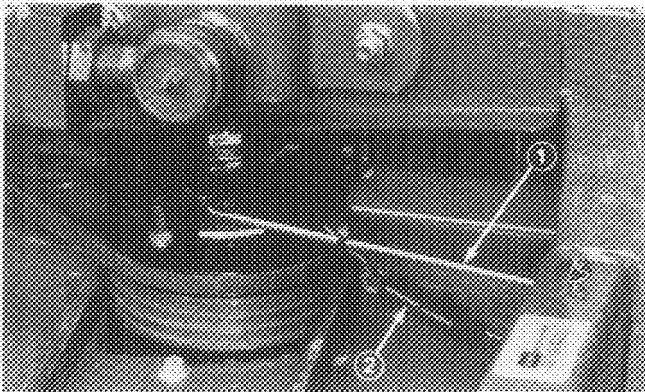

Figure 66

1. Clutch Rod
2. Clutch Wire

5. To relieve tension on center deck belt, pull back on idler pulley until holes in idler adjuster tube and tube sleeve are aligned. Thread a 5/16–18 capscrew into holes retaining parts.

### To Remove Center Deck Belt

6. Wing deck belts must be removed before center deck belt can be removed, repeat steps 1 – 3.

7. Remove (2) flange head screws securing drive shaft cover to gear box support and remove cover.

8. Remove capscrews and nuts securing front of gear box support to deck channels and loosen capscrews securing rear of gear box support to deck channels.

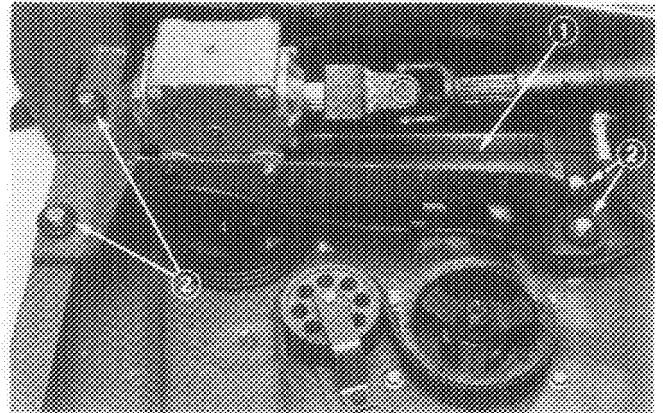

Figure 67

1. Gear Box Support
2. Capscrews & Nuts

9. Raise front of gear box support and remove old belt from around gear box pulley and remaining pulleys.

10. Route new belt around appropriate pulleys as shown in figure 68.

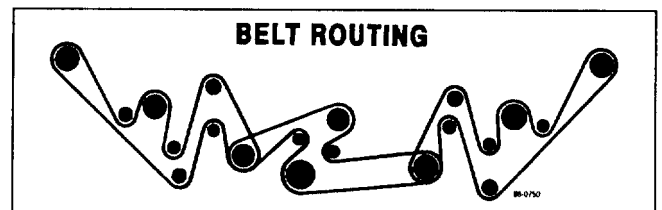

Figure 68

11. Remount gear box support to deck channels with capscrews and nuts previously removed.

12. Reinstall drive shaft cover to gear box support with (4) flange head screws previously removed.

13. Remount clutch rod to deck with hair pin cotter and plug clutch connector into harness.

14. While holding idler pulley adjuster in position, carefully remove capscrew securing idler adjuster tube to tube sleeve. Allow idler pulley to release, tensioning belt.

15. Check idler pulley adjustment, refer to Adjusting Belt Tension, page 34.

16. Reinstall belt covers.

# CUTTING UNIT MAINTENANCE

## ADJUSTING DECK CLUTCH (Fig. 69)

The deck clutches are adjustable to ensure proper engagement and blade braking. Check clutch adjustment after every 250 hours of operation and adjust if required.

1. To adjust clutch, tighten or loosen locknuts on flange studs.
2. Check adjustment by inserting feeler gauge thru slots next to flange studs.
3. The proper disengaged clearance between the clutch plates is .011 – .021 inches. It will be necessary to check this clearance at each of the three slots to ensure the plates are parallel to each other.

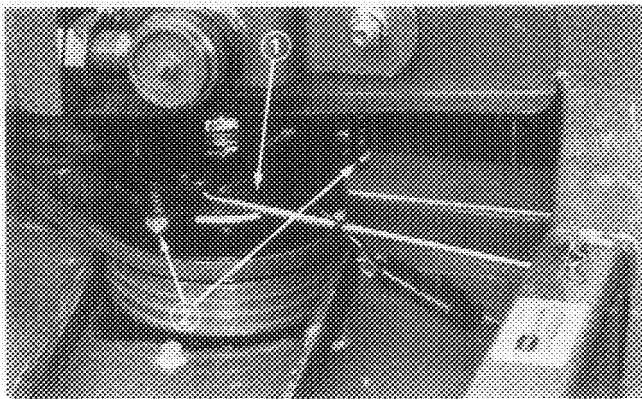

**Figure 69**

1. Clutch
2. Flange studs

## SERVICING FRONT BUSHINGS IN CASTOR ARMS (Fig. 70)

The castor arms have bushings pressed into the top and bottom of the tube and after many hours of operation, the bushings will wear. To check the bushings, move castor fork back and forth and from side to side. If castor spindle is loose inside the bushings, bushings are worn and must be replaced.

1. Raise cutting unit so wheels are off floor and block it so it cannot fall accidentally.
2. Remove lynch pin and spacer(s) from top of castor spindle.
3. Pull castor spindle out of mounting tube. Allow spacer(s) to remain on bottom of spindle.
4. Insert pin punch into top or bottom of mounting tube and drive bushing out of tube. Also drive other bushing out of tube. Clean inside of tubes to remove dirt.
5. Apply grease to inside and outside of new bushings. Using a hammer and flat plate, drive bushings into mounting tube.

6. Inspect castor spindle for wear and replace it if damaged.

7. Push castor spindle through bushings and mounting tube. Slide spacer(s) onto spindle. Install lynch pin on castor spindle to retain all parts in place.

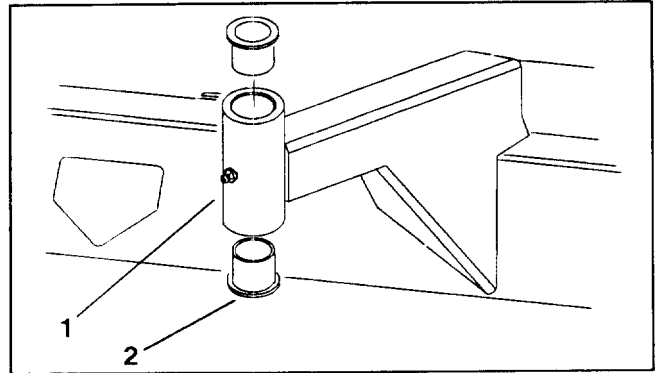

**Figure 70**

1. Front Castor Arm Tube
2. Bushings

## SERVICING CASTOR WHEELS AND BEARINGS (Fig. 71–72)

The castor wheel rotates on high quality ball bearings and is supported by a bearing spacer. Even after many hours of use, provided that the bearings were kept well-lubricated, bearing wear will be minimal. However, failure to keep bearings lubricated will cause rapid wear. A wobbly castor wheel usually indicates a worn bearing.

1. Remove locknut from capscrew holding castor wheel assembly between front castor fork (Fig. 71), or rear castor pivot arm (Fig. 72). Grasp castor wheel and slide capscrew out of fork or pivot arm.

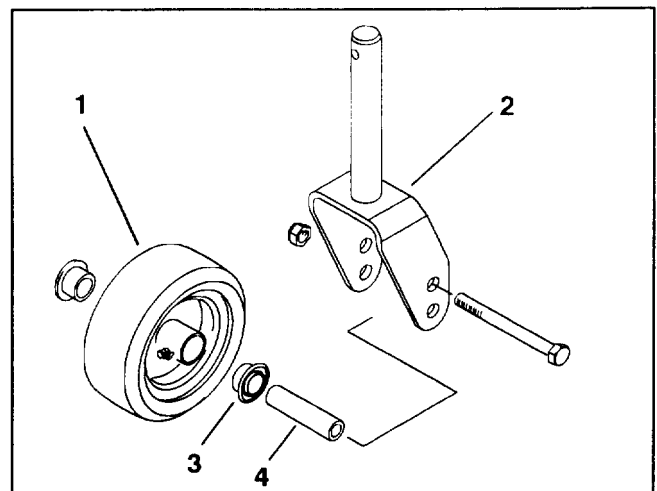

**Figure 71**

1. Castor wheel
2. Front Castor Fork
3. Bearing (2)
4. Bearing Spacer

# CUTTING UNIT MAINTENANCE

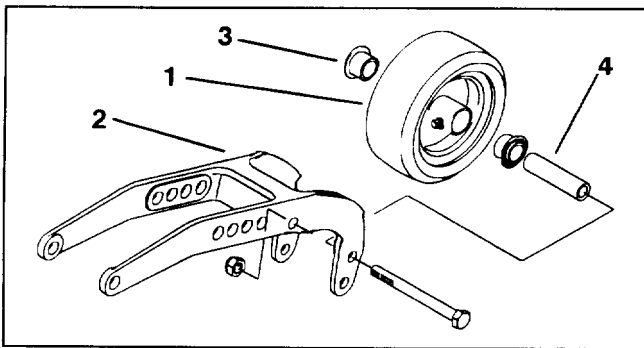

**Figure 72**

- |                          |                   |
|--------------------------|-------------------|
| 1. Castor wheel          | 3. Bearing (2)    |
| 2. Rear Castor Pivot Arm | 4. Bearing Spacer |

- Remove bearing from wheel hub and allow bearing spacer to fall out. Remove bearing from opposite side of wheel hub.
- Check the bearings, spacer and inside of wheel hub for wear. Replace defective parts.
- To assemble the castor wheel, push bearing into wheel hub. Slide bearing spacer into wheel hub. Push other bearing into open end of wheel hub to captivate the bearing spacer inside the wheel hub.
- Install castor wheel assembly between castor fork and secure in place with capscrew and locknut.
- Lubricate castor wheel bearing through grease fitting, using No. 2 general purpose lithium base grease.

## REMOVING CUTTER BLADE (Fig. 73)

The blade must be replaced if a solid object is hit, the blade is out-of-balance or if the blade is bent. Always use genuine TORO replacement blades to be sure of safety and optimum performance. Never use replacement blades made by other manufacturers because they could be dangerous.



### WARNING

**Do not try to straighten a blade that is bent, and never weld a broken or cracked blade. Always use a new blade to assure continued safety certification of the product.**

- Raise cutting unit to highest position, shut the engine off and engage the parking brake. Block cutting unit to prevent it from falling accidentally.
- Grasp end of blade using a rag or thickly padded glove. Remove blade bolt, lockwasher, anti-scalp cup and blade from spindle shaft.
- Install blade—sail facing toward cutting unit with anti-scalp cup, lockwasher and blade bolt. Tighten blade bolt to 85–110 ft-lb.

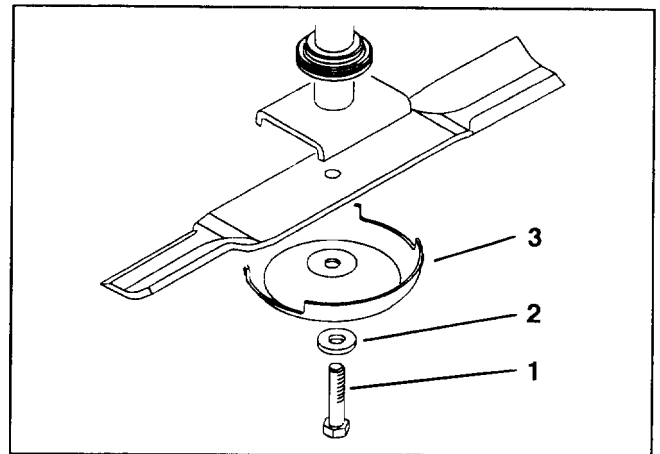

**Figure 73**

- |                   |
|-------------------|
| 1. Blade bolt     |
| 2. Lockwasher     |
| 3. Anti-Scalp Cup |

## INSPECTING AND SHARPENING BLADE

(Fig. 74)

- Raise cutting unit to highest position, shut the engine off and engage the parking brake. Block cutting unit to prevent it from falling accidentally.
- Examine cutting ends of the blade carefully, especially where the flat and curved parts of the blade meet (Fig. 74-A). Since sand and abrasive material can wear away the metal that connects the flat and curved parts of the blade, check the blade before using the machine. If wear is noticed (Fig. 74-B), replace the blade: refer to Removing Cutter Blade, page 37.

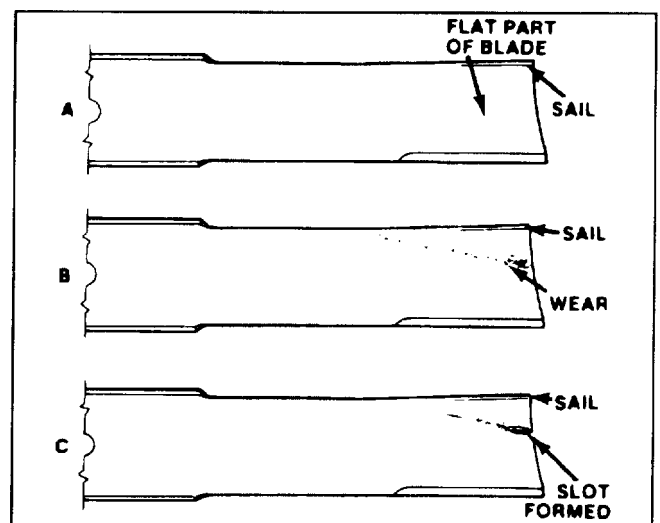

**Figure 74**

- Inspect cutting edges of all blades. Sharpen the cutting edges if they are dull or nicked. Sharpen only the top of the cutting edge and maintain the original cutting angle to make sure of sharpness (Fig. 75). The blade will remain balanced if same amount of metal is removed from both cutting edges.

# CUTTING UNIT MAINTENANCE

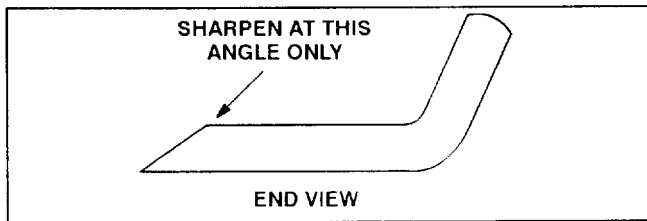

Figure 75

4. To check blade for being straight and parallel, lay blade on a level surface and check its ends. Ends of blade must be slightly lower than the center, and cutting edge must be lower than the heel of the blade. This blade will produce good quality of cut and require minimal power from the engine. By contrast a blade that is higher at the ends than the center, or if cutting edge is higher than the heel, the blade is bent or warped and must be replaced.

5. Install blade—sail facing toward cutting unit with anti-scalp cup, lockwasher and blade bolt. Tighten blade bolt to 85–110 ft–lb.

## PREPARATION FOR SEASONAL STORAGE

### Traction Unit

1. Thoroughly clean the traction unit, cutting units and the engine.
2. Check the tire pressure. Inflate all tires to 20 psi.
3. Check all fasteners for looseness; tighten as necessary.
4. Grease or oil all grease fittings and pivot points. Wipe up any excess lubricant.
5. Lightly sand and use touch-up paint on painted areas that are scratched, chipped, or rusted. Repair any dents in the metal body.
6. Service the battery and cables as follows:
  - a. Remove the battery terminals from the battery posts.
  - b. Clean the battery, terminals, and posts with a wire brush and baking soda solution.
  - c. Coat the cable terminals and battery posts with Grafo 112X skin-over grease (Toro Part No. 505-47) or petroleum jelly to prevent corrosion.
  - d. Slowly recharge the battery every 60 days for 24 hours to prevent lead sulfation of the battery.

### Engine

1. Drain the engine oil from the oil pan and replace the drain plug.
2. Remove and discard the oil filter. Install a new oil filter.
3. Refill oil pan with 5.3 quarts of SAE10W-30 CD motor oil.

4. Start the engine and run at idle speed for approximately two minutes.
5. Stop the engine.
6. Flush the fuel tank with fresh, clean diesel fuel.
7. Resecure all fuel system fittings.
8. Thoroughly clean and service the air cleaner assembly.
9. Seal the air cleaner inlet and the exhaust outlet with weatherproof tape.
10. Check anti freeze protection and add a 50/50 solution of water and Peugeot recommended anti freeze as needed for expected minimum temperature in your area.

### Cutting Unit

1. Check blades and tighten blade bolts to 85–110 ft–lb.
2. Check and lubricate caster arm bushings.
3. Check and lubricate caster wheel bearings. Tighten caster wheel nuts to 140–165 ft–lb.
4. Check all fasteners for looseness; tighten as necessary.
5. Grease or oil all grease fittings and pivot points. Wipe up any excess lubricant.
6. Lightly sand and use touch-up paint on painted areas that are scratched, chipped, or rusted.
7. Check drive belts.
8. Clean thoroughly top and underside.

# MAINTENANCE CHART

Date	Hours Used							

# The Toro Promise

## A LIMITED WARRANTY

*The Toro Company promises to repair your Model 30450 or 30455 TORO GROUNDMASTER® MOWER, and its cutting unit, if defective in materials or workmanship. The following time periods from the date of purchase apply:*

Model 30450 or 30455 . . . . . Two Years or 1500 operational hours,  
whichever comes first.

*The costs of parts, labor and transportation are included.*

If you feel your TORO product is defective and wish to rely on The Toro Promise, the following procedure is recommended:

1. Contact your Authorized TORO Distributor or Commercial Dealer (the Yellow Pages of your telephone directory is a good reference source).
2. The TORO Distributor or Commercial Dealer will advise you on the arrangements that can be made to inspect and repair your product.
3. The TORO Distributor or Commercial Dealer will inspect the product and advise you whether the product is defective and, if so, make all repairs necessary to correct the defect without an extra charge to you.

If for any reason you are dissatisfied with the distributor's analysis of the defect or the service performed, you may contact us.

Write:

TORO Commercial Products Service Department  
8111 Lyndale Avenue South  
Minneapolis, Minnesota 55420

The above remedy of product defects through repair by an Authorized TORO Distributor or Commercial Dealer is the purchaser's sole remedy for any defect.

**THERE IS NO OTHER EXPRESS WARRANTY. ALL IMPLIED WARRANTIES OF MERCHANTABILITY AND FITNESS FOR USE ARE LIMITED TO THE DURATION OF THE EXPRESS WARRANTY.**

Some states do not allow limitations on how long an implied warranty lasts, so the above limitation may not apply to you.

This Warranty applies only to parts or components which are defective and does not cover repairs necessary due to normal wear, misuse, accidents, or lack of proper maintenance. Regular, routine maintenance of the unit to keep it in proper condition is the responsibility of the owner.

All warranty repairs reimbursable under the Toro Promise must be performed by an Authorized TORO Commercial Dealer or Distributor using Toro approved replacement parts.

Repairs or attempted repairs by anyone other than an Authorized TORO Distributor or Commercial Dealer are not reimbursable under the Toro Promise. In addition, these unauthorized repair attempts may result in additional malfunctions, the correction of which is not covered by warranty.

**THE TORO COMPANY IS NOT LIABLE FOR INDIRECT, INCIDENTAL OR CONSEQUENTIAL DAMAGES IN CONNECTION WITH THE USE OF THE PRODUCT INCLUDING ANY COST OR EXPENSE OF PROVIDING SUBSTITUTE EQUIPMENT OR SERVICE DURING PERIODS OF MALFUNCTION OR NON-USE.**

Some states do not allow the exclusion or limitation of incidental or consequential damages, so the above limitation or exclusion may not apply to you.

This warranty gives you specific legal rights, and you may also have other rights which vary from state to state.

### COUNTRIES OTHER THAN THE UNITED STATES OR CANADA

Customers who have purchased TORO products exported from the United States or Canada should contact their TORO Distributor (Dealer) to obtain guarantee policies for your country, province or state. If for any reason

you are dissatisfied with your Distributor's service or have difficulty obtaining guarantee information, contact the TORO importer. If all other remedies fail, you may contact us at The Toro Company