

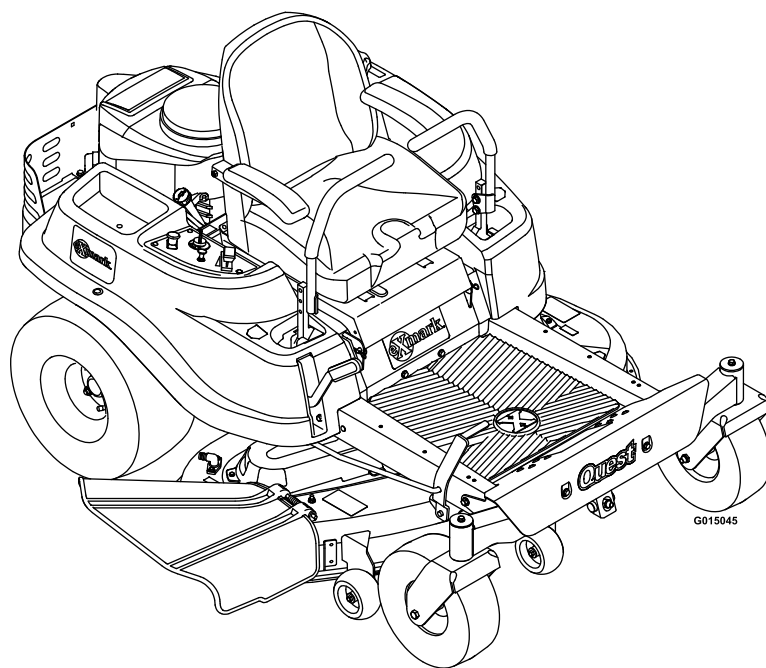

QUEST®

Model No. QTE735KC421 —Serial No. 31400000 and Up

Picture below may not reflect actual product.



Parts Manual

Ordering Replacement Parts

To order replacement parts, please supply the part number, the quantity, and the description of each part desired.

Understanding Reference Numbers

Each identified part in an illustration has a reference number. The reference number for a part also appears in the parts list, along with other information about the part.

This catalog uses two special reference number formats, one to indicate parts in a service assembly and another to indicate the quantity of a given part in an illustration.

Service Assembly Reference Numbers

Parts in service assemblies have reference numbers in the form a:b. The a represents the reference number of the entire service assembly and the b represents a sequential number unique to each part within the service assembly.

For example, a wheel assembly might be identified by reference number 6, the tire by 6:1, the valve by 6:2, and the wheel by 6:3. When you order the assembly identified by reference number 6, you receive all parts identified by reference numbers 6:1, 6:2, and 6:3. However, you may also order any part individually. Reference numbers of this type appear in illustration and in parts lists.

Reference Numbers Indicating Quantity

In an illustration, if a reference number indicates more than one part, the reference number has the form nX y. The n represents the quantity of the part, the X is the multiplication symbol, and the y represents the reference number.

For example, in an illustration, the reference number 2X 37 means that two of the parts identified by reference number 37 are indicated.

List of Abbreviations

AR: as required	HJ: hex jam	PRH: phillips round head
ASM: assembly	HLH: hex lag head	PTH: phillips truss head
BBC: blade brake control	HOC: height-of-cut	PTO: power-take-off
BHTF: button head thread forming	HSBH: hex socket button head	RH: right hand
CARR: carriage	HSFH: hex socket flat head	ROPS: roll-over protection system
CCW: counter clockwise	HSH: hex socket head	RRB: rear roller brush
CW: clockwise	HWH: hex washer head	SFH: slotted fillister head
DEG: degrees	HWHTF: hex washer head thread forming	SHH: slotted hex head
DPA: Dual Point Adjustment	HYD: hydraulic	SHWH: slotted hex washer head
ECM: electronic control module	LH: left hand	SPH: slotted pan head
EXT: external	LP: Liquefied Petroleum Gas	SQH: square head
FH: flat head	LPG: Liquefied Petroleum Gas	SRH: slotted round head
GA: gauge	NI: nylon insert	STD: standard
HD: heavy-duty	NPTF: national pipe thread fine	TAP: self tapping
HF: hex flange	PFH: phillips flat head	TTH: torx truss head
HH: hex head	PPH: phillips pan head	
HHF: hex head flange	PPHTF: phillips pan head thread forming	
HHFTF: hex head flange thread forming		

Touch Up Paint

Exmark black touch up spray paint – gloss black.

Exmark red touch up paint (spray paint – P/N 1-850337 - .6 oz liquid bottle – P/N 103-9140).



If your Exmark dealer does not have the Exmark part in stock, Exmark will get the parts to the dealer the next business day or the part will be FREE Guaranteed!! (Some restrictions apply. See your participating Exmark Dealer for details.)

Contents

42 Inch Deck Assembly	4
42 Inch Deck Assembly No. 119-8840	5
42 Inch Deck, Belt and Blade Assembly	6
Main Frame and Front Axle Assembly	7
Caster Wheel Assembly No. 130-0736	8
Deck Lift Assembly	10
Motion Control Assembly	11
Controls and Fuel Tank	12
Fuel Delivery Assembly	14
Engine and Muffler Assembly	16
Clutch Assembly	18
Hydro Transaxle Drive and Rear Wheel Assembly	20
Left Hand Hydro Transaxle Assembly No. 119-3330	22
Right Hand Hydro Transaxle Assembly No. 119-3331	24
Belt and Idler Assembly	26
Seat Assembly	28
Electrical Assembly	29

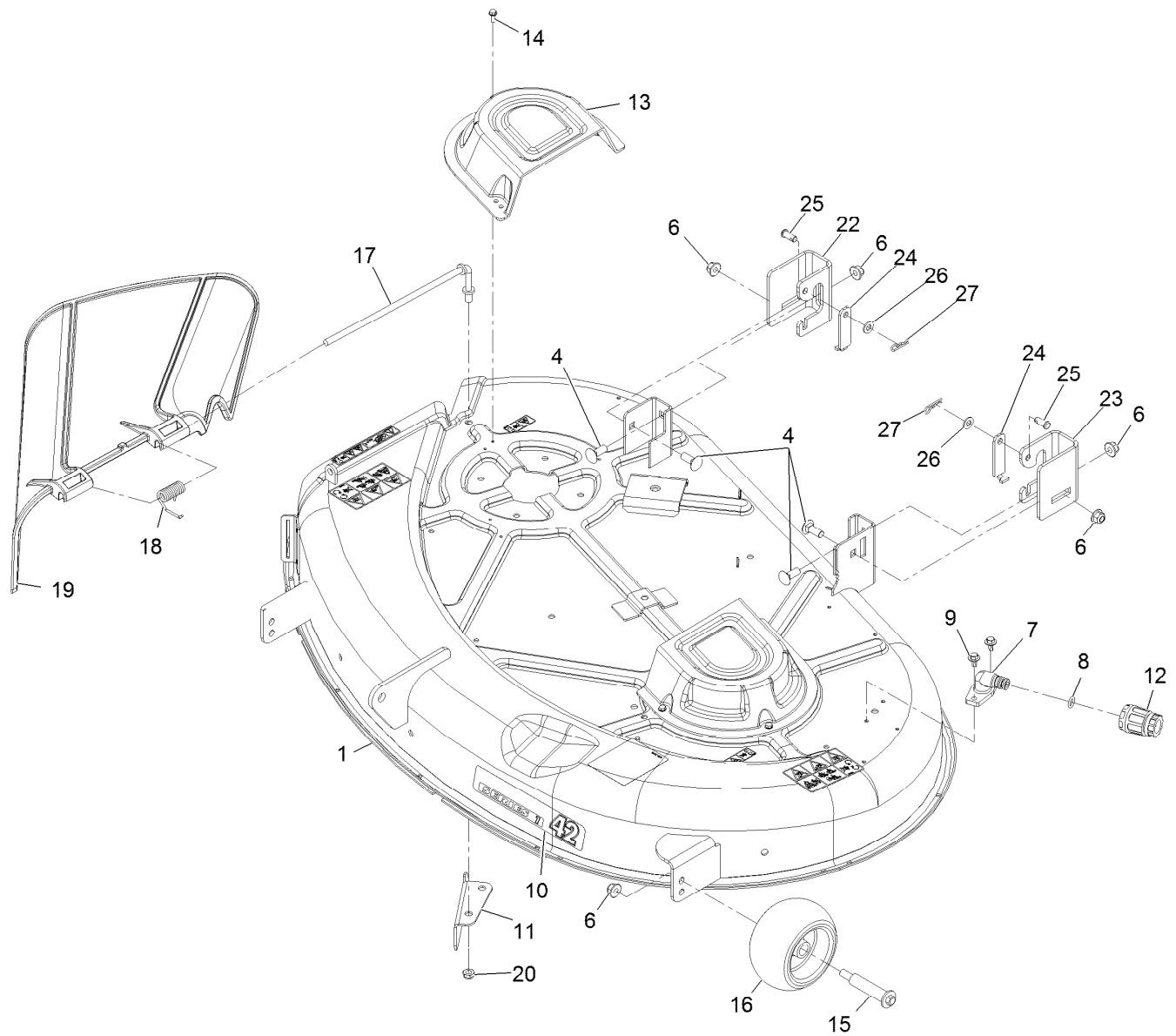

42 Inch Deck Assembly

Ref.	Part Number	Qty.	Description	Ref.	Part Number	Qty.	Description
1	119-8840	1	42 Inch Deck And Decal ASM	15	112-3977	2	Bolt-HH Shoulder 3/8-16 X 3.79
4	3231-2	4	Bolt-Carriage 3/8-16 X 1	16	1-603299	2	Roller-Scalp, Anti
6	104-8301	6	Nut-Nyloc 3/8-16 Flg	17	112-4026	1	Rod-Pivot
7	95-2747	1	Fitting-Washout	18	110-6694	1	Spring-Torsion
8	46-6290	1	O-Ring	19	112-3951	1	Deflector
9	46-8560	2	Screw-HHF 1/4-20 X 1/2	20	3296-59	1	Nut-Nyloc 3/8-16 Thin
10	126-1769	1	Decal-Series 1 - 42	22	130-6888	1	Bracket - Hanger, Rr
11	112-3983-03	1	Baffle-Cutoff	23	130-6890	1	Bracket - Hanger, Lr
12	95-3270	1	Connector-Hose	24	130-6891	2	Link - Deck Retention
13	108-7889	2	Cover-Belt	25	283-62	2	Pin-Clevis
14	32144-1	6	Screw-HWH #10-24 X 1/2 Taptite	26	3256-23	2	Washer-Flat
				27	1-806003	2	Pin-Cotter, Hair

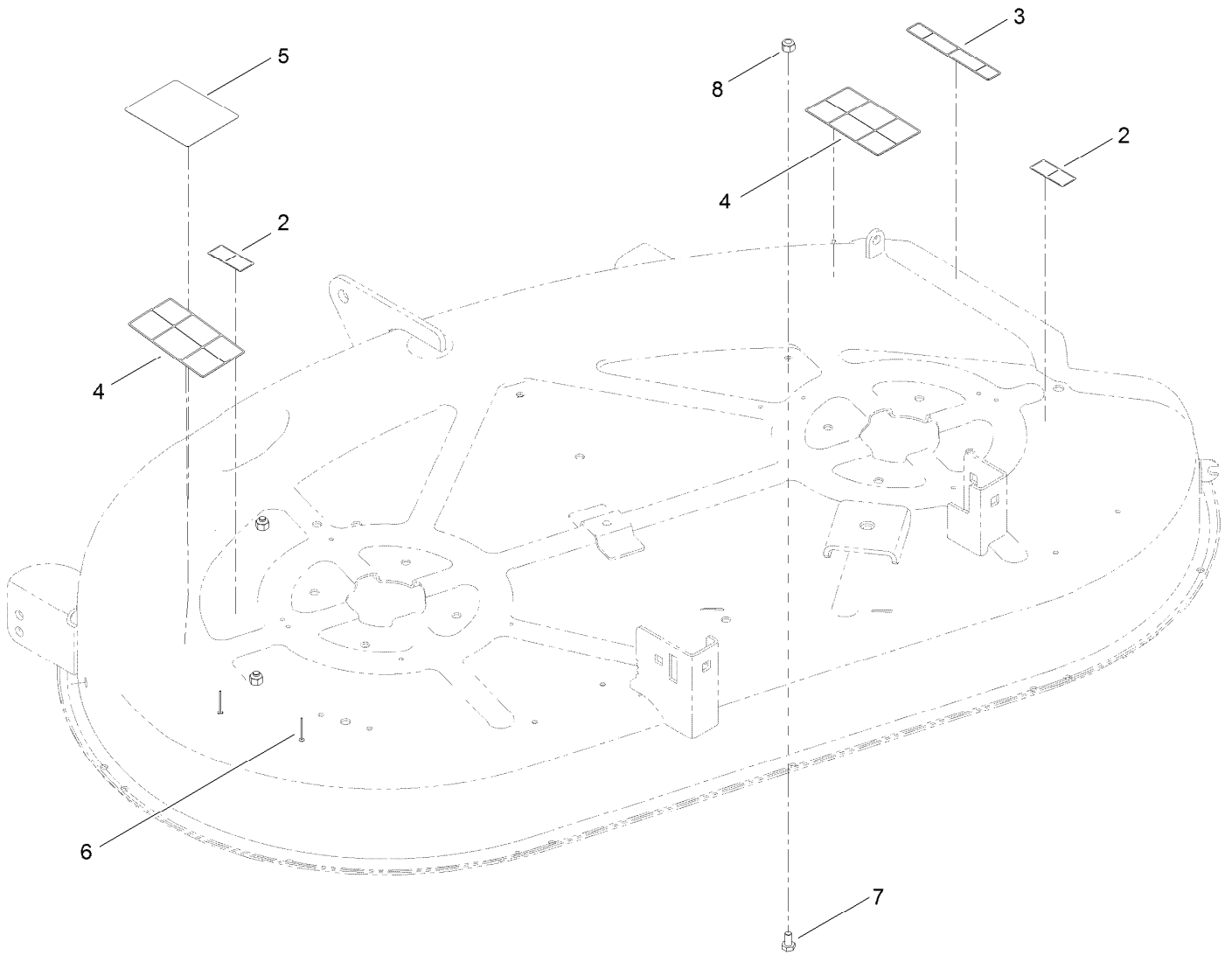

42 Inch Deck Assembly No. 119-8840

<i>Ref.</i>	<i>Part Number</i>	<i>Qty.</i>	<i>Description</i>
2	114-1606	2	Decal-Danger
3	93-7009	1	Decal-Danger
4	110-6691	2	Decal-Danger
5	105-7015	1	Decal-Routing, Belt
6	3290-282	2	Rivet-Blind
7	321-2	3	Screw-HH
8	3296-42	3	Nut-Lock, NI

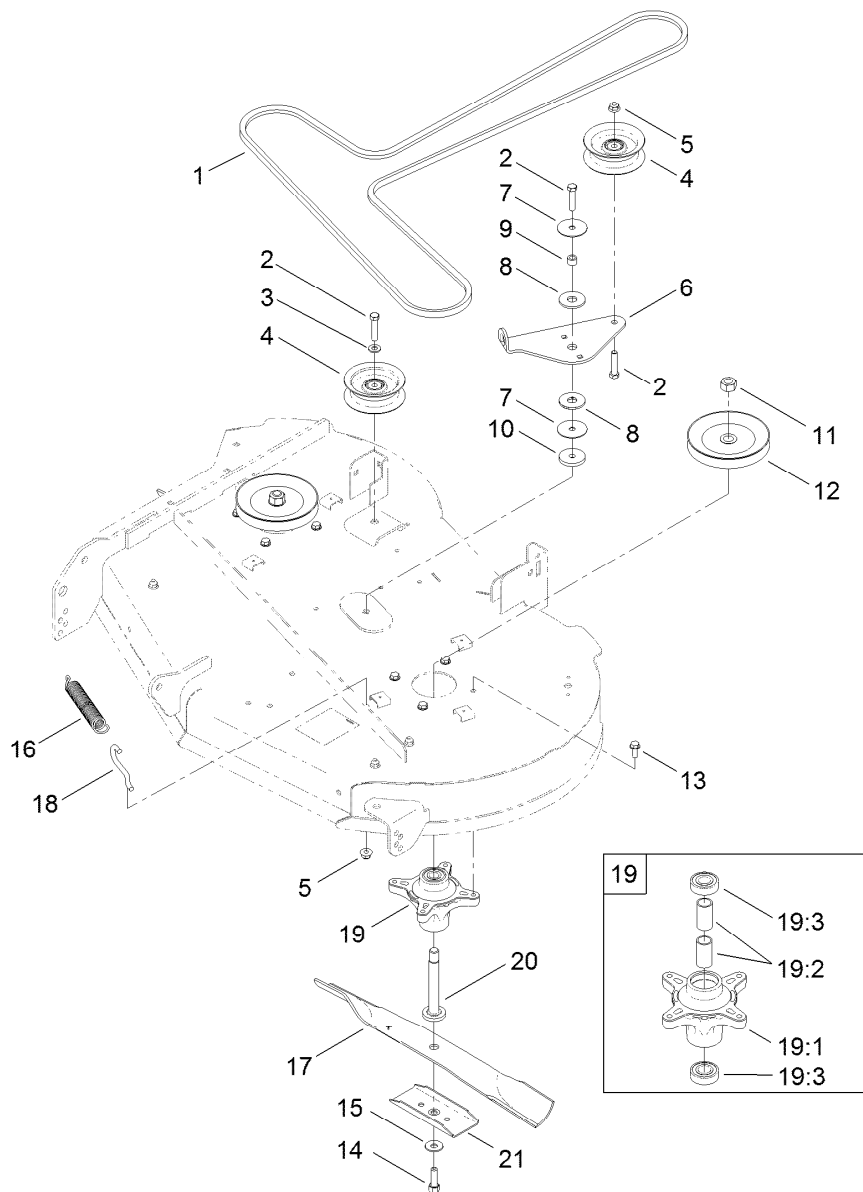

42 Inch Deck, Belt and Blade Assembly

Ref.	Part Number	Qty.	Description
1	119-8819	1	V-Belt
2	323-9	2	Screw-HH
3	3256-24	1	Washer-Flat
4	106-2175	2	Pulley-Idler, Flat
5	104-8301	1	Nut-Flange, NI
6	114-8540	1	Arm-Idler
7	120-2229	2	Washer-Idler Pivot
8	114-0463	2	Washer-Friction, Composite
9	115-4986	1	Spacer
10	323-7	1	Screw-HH
11	3219-6	2	Nut-Hex
12	125-5574	2	Pulley

Ref.	Part Number	Qty.	Description
13	32144-41	8	Screw-Taptite
14	26-0671	2	Screw-HH
15	3290-465	2	Washer-Belleville
16	106-2177	1	Spring-Extension
17	110-6568-03	2	Blade-21.6 Inch
18	88-5970	1	Hook-Return, Spring
19	121-0751	2	Spindle ASM
19:1	117-7267	1	Spindle
19:2	120-7935	2	Spacer
19:3	100-1048	2	Bearing-Ball
20	117-7268	2	Shaft-Spindle
21	106-2248-03	2	Stiffener-Blade

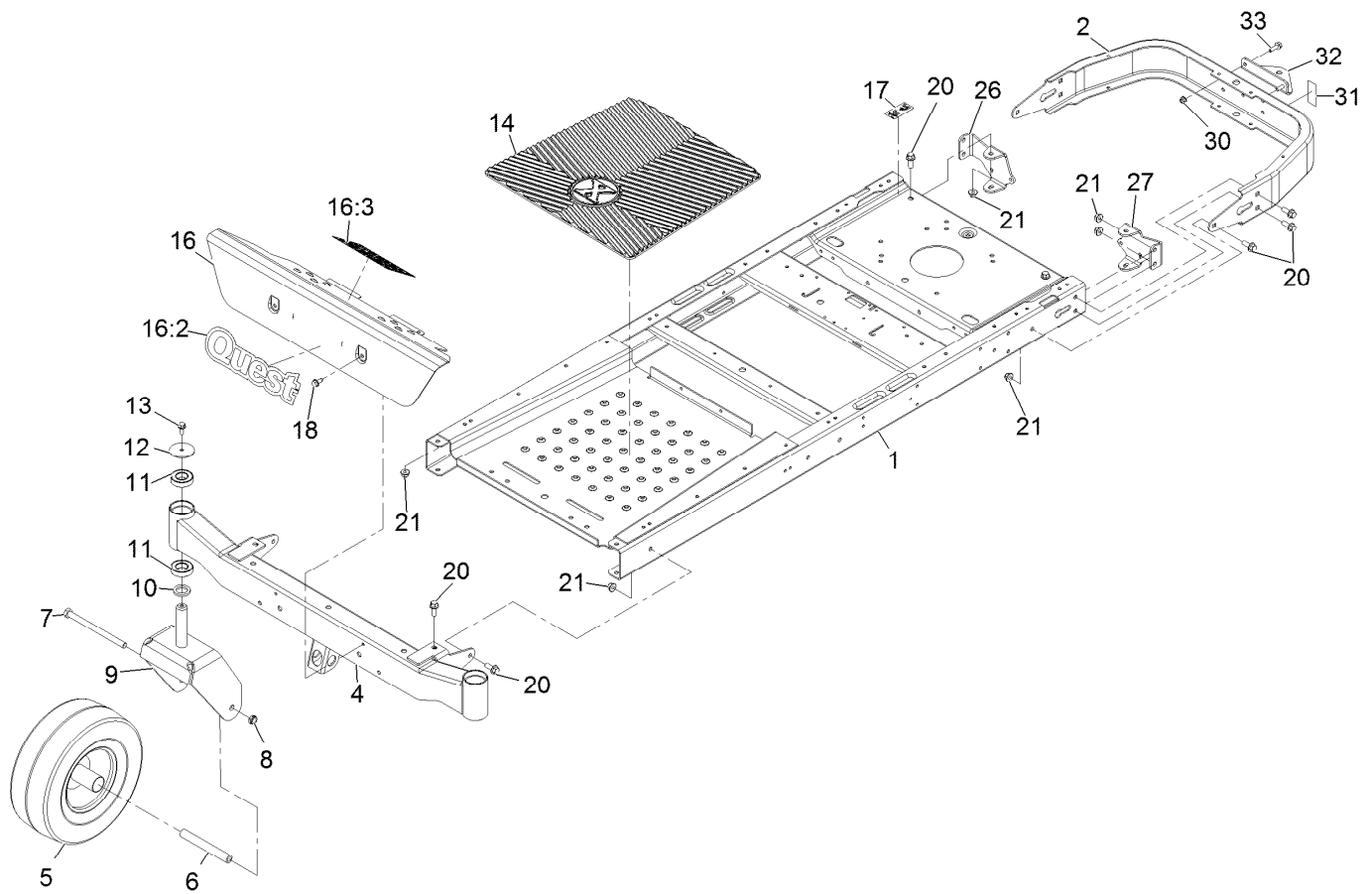

Main Frame and Front Axle Assembly

<i>Ref.</i>	<i>Part Number</i>	<i>Qty.</i>	<i>Description</i>	<i>Ref.</i>	<i>Part Number</i>	<i>Qty.</i>	<i>Description</i>
1	121-2970-01	1	Frame	16:2	116-4218	1	Decal
2	110-1920-01	1	Bumper-Rear	16:3	120-2239	1	Decal-Danger
4	120-5516-01	1	Axle-Front	17	121-2989	2	Decal-Bypass
5	130-0736	2	Caster Wheel ASM	18	32144-70	2	Screw-HWH 5/16-18 X 3/4 Tf
6	104-3667	2	Spanner-Wheel	20	3234-42	14	Screw HHF 3/8-16 X 1
7	325-22	2	Screw-HH 1/2-13 X 5 1/2	21	104-8301	14	Nut-Nyloc 3/8-16 Flg
8	3296-45	2	Nut-Nyloc 1/2-13 Thin	26	121-0737-01	1	Mount-Hydro, Rear (RH)
9	120-2266-01	2	Fork-Caster	27	121-0738-01	1	Mount-Hydro, Rear (LH)
10	117-7394	2	Washer-Thrust	30	104-8300	2	Nut-Nyloc 5/16-18 Flg
11	109-3678	4	Bearing-Ball	31	109-7076	1	Decal
12	119-8915	2	Washer	32	117-1232-03	1	Bracket-Hitch
13	3234-47	2	Screw-HH Flg 5/16-18 X 3/4	33	3234-29	2	Screw-HH Flg 5/16-18 X 1
14	120-5457	1	Mat-Floor				
16	125-0071	1	Footrest ASM				

Caster Wheel Assembly No. 130-0736

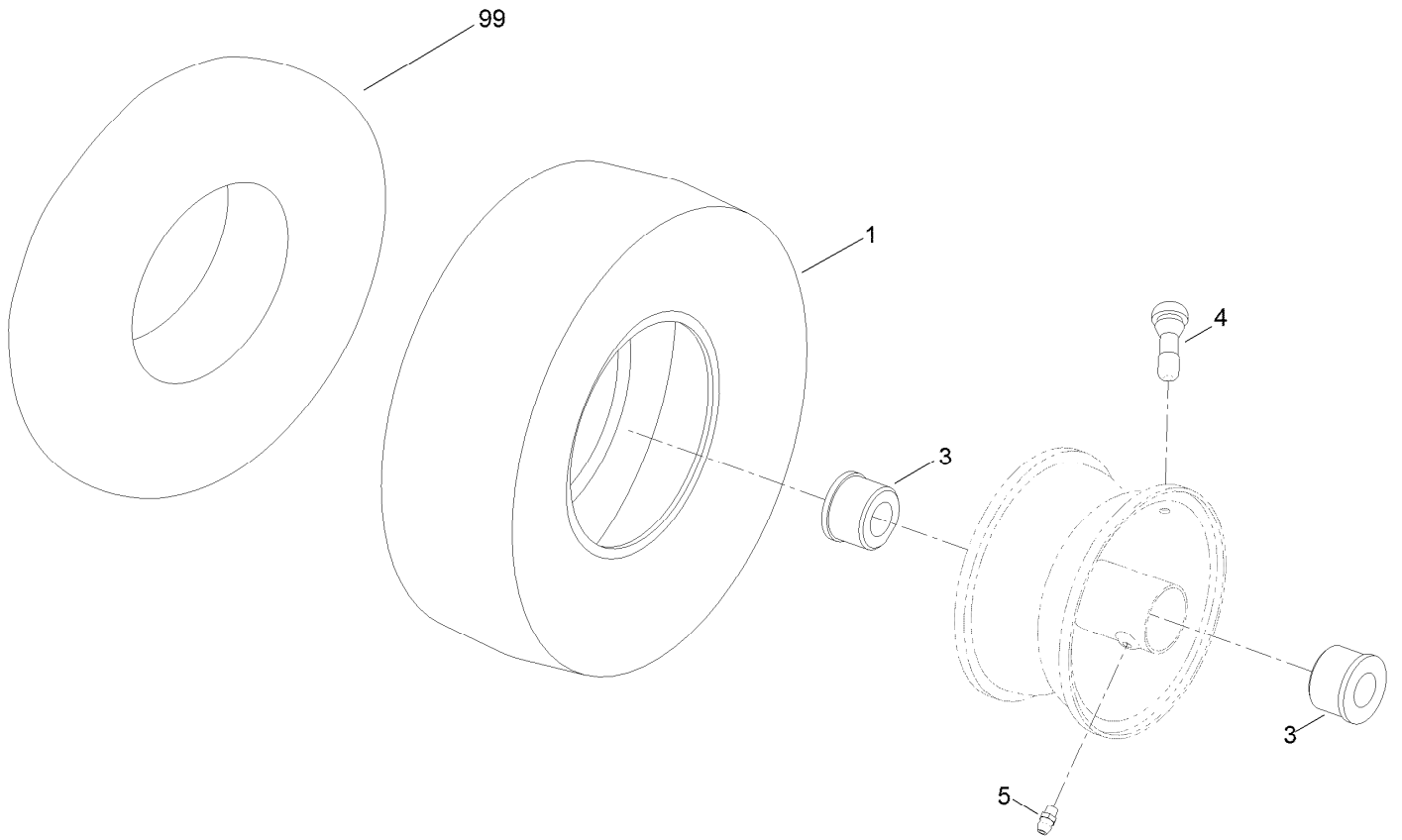

Caster Wheel Assembly No. 130-0736 (continued)

<i>Ref.</i>	<i>Part Number</i>	<i>Qty.</i>	<i>Description</i>
1	130-0735	1	Tire
3	114-1640	2	Bushing-Flange
4	232-27	1	Stem-Valve

<i>Ref.</i>	<i>Part Number</i>	<i>Qty.</i>	<i>Description</i>
5	302-5	1	Fitting-Grease
99	105-0844	1	Tube-Inner

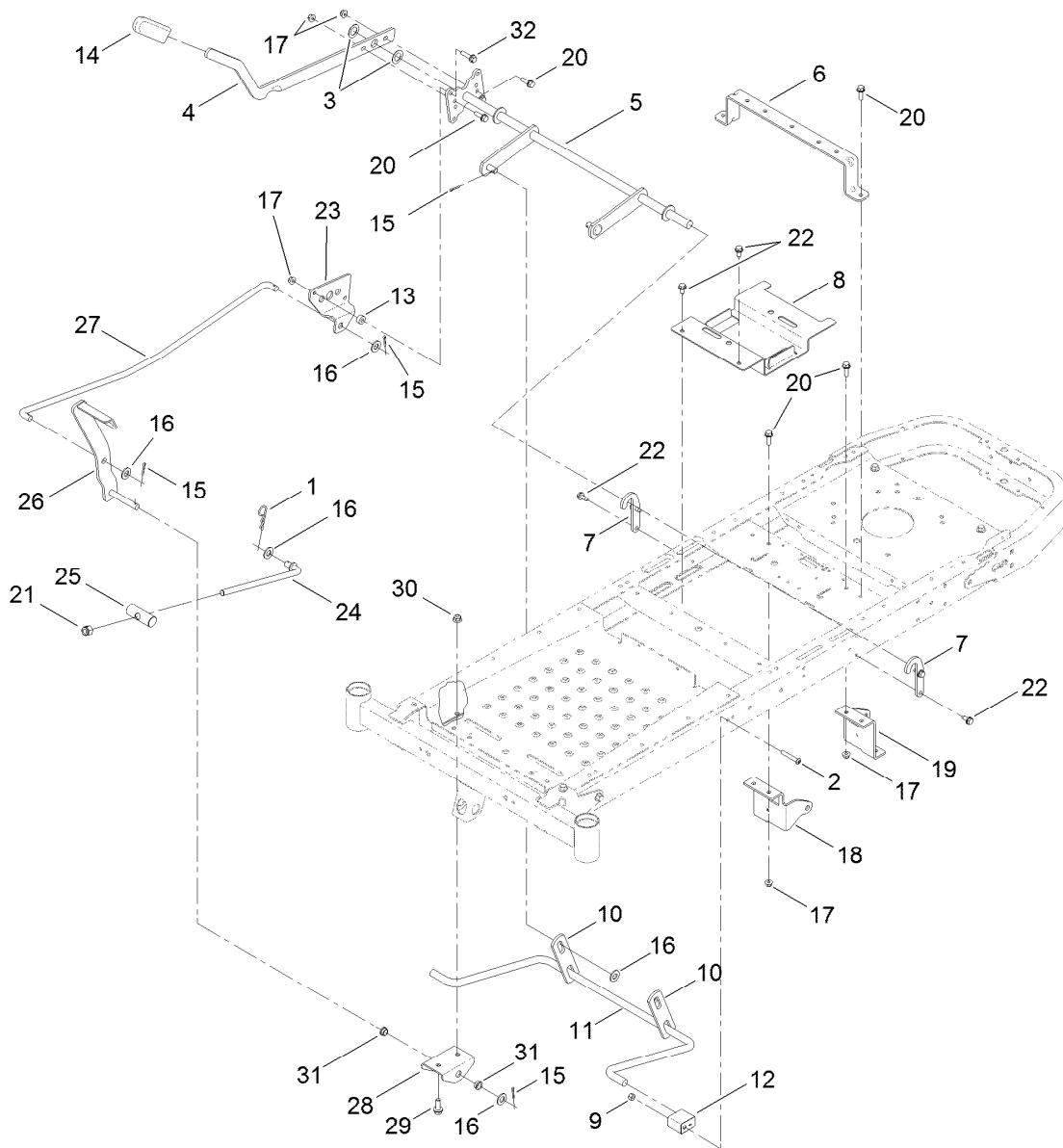

Deck Lift Assembly

Ref.	Part Number	Qty.	Description	Ref.	Part Number	Qty.	Description
1	1-806005	1	Hairpin-Cotter	18	119-8861-01	1	Mount-Hydro, Front (RH)
2	120-5499	2	Screw-HSBH	19	119-8862-01	1	Mount-Hydro, Front (LH)
3	3-6498	2	Washer-Thrust	20	3234-29	4	Screw-HH Flg 5/16-18 X 1
4	119-3427-03	1	Lever-Lift	21	3296-19	1	Nut-Nyloc 1/2-20
5	117-7346-03	1	Lift-Deck	22	32144-70	6	Screw-HWH 5/16-18 X 3/4 Tf
6	119-3435-03	1	Brace-Seat, Rear	23	120-2275	1	Plate-Footlift
7	119-8875	2	Bracket-Lift	24	104-8047	1	Rod-Trunion
8	119-3406-03	1	Bracket-Battery	25	119-8810	1	Pin-Pivot
9	3296-29	2	Nut-Nyloc 5/16-18	26	120-2276-01	1	Pedal ASM
10	108-7840	2	Link-Lift	27	120-2242	1	Rod-Footlift
11	108-7839	1	Arm-Lift, Rear	28	120-2294-01	1	Bracket-Footlift
12	108-7845	2	Block-Pivot	29	3234-42	2	Screw HHF 3/8-16 X 1
13	121-1759	2	Spacer	30	104-8301	2	Nut-Nyloc 3/8-16 Flg
14	1-633268	1	Grip-Lever	31	256-156	2	Bushing-Flange
15	3272-10	5	Pin-Cotter 1/8 X 3/4	32	3234-36	2	Screw-HH Flg 5/16-18 X 1 1/4
16	3256-26	6	Washer-1/2 Sae				
17	104-8300	6	Nut-Nyloc 5/16-18 Flg				

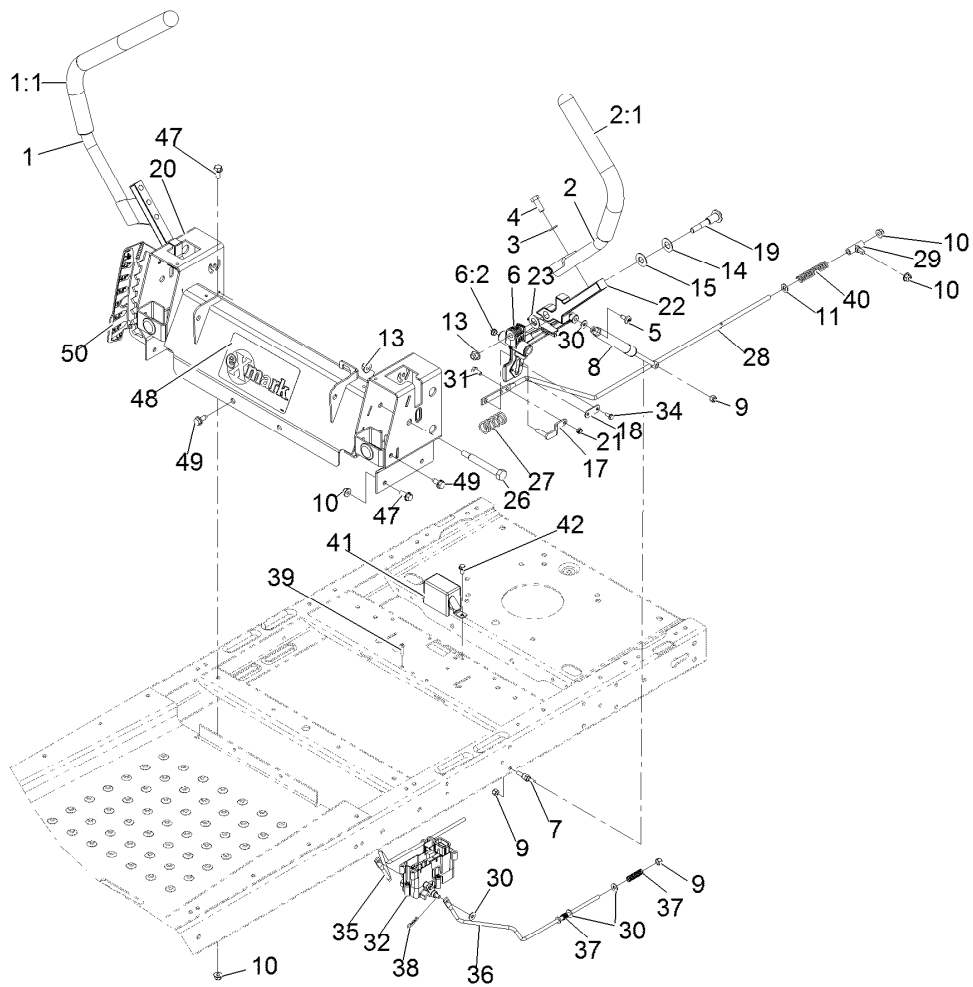

Motion Control Assembly

Ref.	Part Number	Qty.	Description	Ref.	Part Number	Qty.	Description
1	121-0731	1	Handle-Control, RH	26	115-5099	2	Bolt-Pivot
1:1	121-0726	1	Grip	27	119-8876	2	Spring-Return
2	121-0730	1	Handle-Control, LH	28	117-5388	2	Rod-Hydro
2:1	121-0726	1	Grip	29	119-8842	2	Mount-Rod, Hydro
3	3256-24	4	Washer-3/8 Sae	30	119-8952	8	Washer
4	323-6	4	Screw-HH 3/8-16 X 1	31	321-3	2	Screw-HH 1/4-20 X 5/8
5	120-7950	2	Screw-Shoulder	32	121-3017	1	Brake Control Module ASM
6	119-3470	2	Actuator Arm ASM	34	32144-1	4	Screw-HWH #10-24 X 1/2 Taptite
6:2	256-156	2	Bushing-Flange	35	121-2974	1	Rod-Brake, RH
7	110-6810	2	Stud-Damper	36	121-2975	1	Rod-Brake, LH
8	103-2913	2	Damper-Control, Motion	37	117-1169	4	Spring-Compression
9	3296-42	6	Nut-Nyloc 1/4-20	38	3290-307	2	Pin-Hair
10	104-8300	10	Nut-Nyloc 5/16-18 Flg	39	32144-36	4	Screw-PPH
11	3256-23	2	Washer-5/16 Sae	40	1-603807	2	Spring
13	104-8301	4	Nut-Nyloc 3/8-16 Flg	41	119-8859	1	Cover-Brake
14	119-8925	2	Washer-Belleville	42	32144-4	1	Screw-HWH 1/4-20 X 1/2 Taptite
15	117-1240	2	Washer	47	3234-47	6	Screw-HH Flg 5/16-18 X 3/4
17	119-3303	2	Pin-Rod, Hydro	48	116-4219	1	Decal
18	119-8948	2	Plate-Stop, Hydro	49	32144-70	4	Screw-HWH 5/16-18 X 3/4 Tf
19	117-1198	2	Bolt-Pivot	50	119-8871	1	Decal
20	125-5473-03	1	Control Box ASM				
21	3296-56	2	Nut-Nyloc 1/4-20 Thin				
22	115-5098-05	2	Lever-Control				
23	120-2273	2	Washer-Nylon				

Controls and Fuel Tank (continued)

<i>Ref.</i>	<i>Part Number</i>	<i>Qty.</i>	<i>Description</i>	<i>Ref.</i>	<i>Part Number</i>	<i>Qty.</i>	<i>Description</i>
1	119-8961	1	Pod-RH	10	120-7950	6	Screw-Shoulder
2	119-8960	1	Pod-LH	11	609830	2	Spring
3	120-5462	1	Decal-Control Panel	12	110-6754	1	Cable-Choke
4	131-1007	1	Cable-Throttle	13	3253-21	1	Washer-Lock 3/8
5	3258-166	3	Screw-PPH 1/4-20 X 3/4	14	3220-3	1	Nut-Jam 3/8-24
6	107069	3	Nut-Retainer-Panel 1/4-20	15	119-8993-03	1	Guard-Rear, Narrow
7	120-5461	1	Cap-Fuel, Ratcheting	17	119-3476-03	1	Support-Tank, Front
8	119-3378-03	1	Plate-Control	18	32144-70	6	Screw-HWH 5/16-18 X 3/4 Tf
9	119-3324	1	Fuel Tank ASM	19	119-8814	1	Decal-Control Lever, LH
9:1	121-0793	1	Connector-Elbow, 90 DEG	20	119-8815	1	Decal-Control Lever, RH
9:2	46-6560	2	Bushing				
9:4	117-7400	1	Fitting-Plastic				

Fuel Delivery Assembly

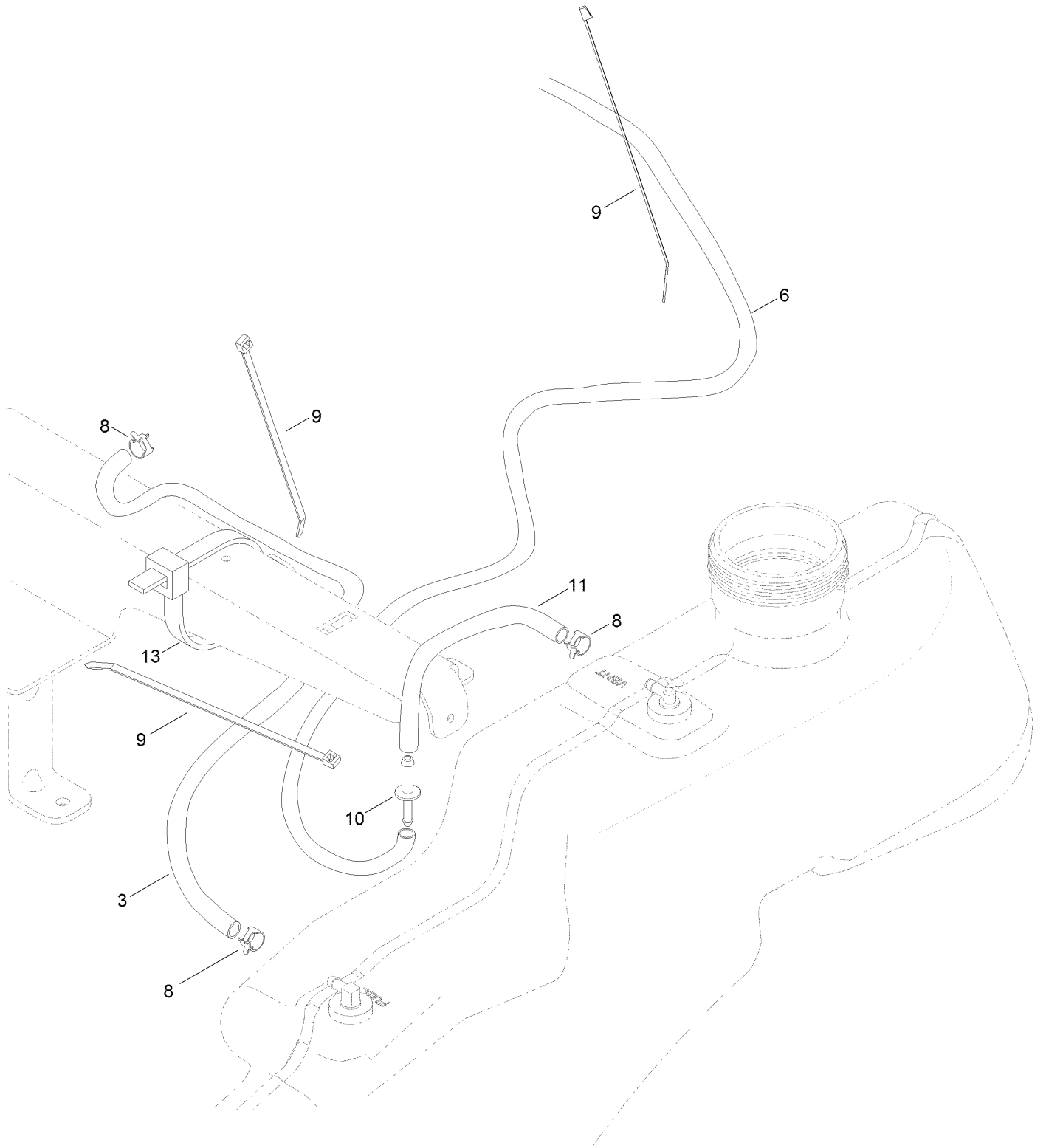

Fuel Delivery Assembly (continued)

<i>Ref.</i>	<i>Part Number</i>	<i>Qty.</i>	<i>Description</i>	<i>Ref.</i>	<i>Part Number</i>	<i>Qty.</i>	<i>Description</i>
3	109-0273	1	Hose-Fuel	10	117-5399	1	Adaptor-Orifice
6	108-9698	1	Hose-Fuel	11	110-1876	1	Hose-Fuel
8	2412-98	3	Clamp-Hose	13	3334-945	2	Tie-Cable
9	614249	3	Tie-Cable				

Engine and Muffler Assembly

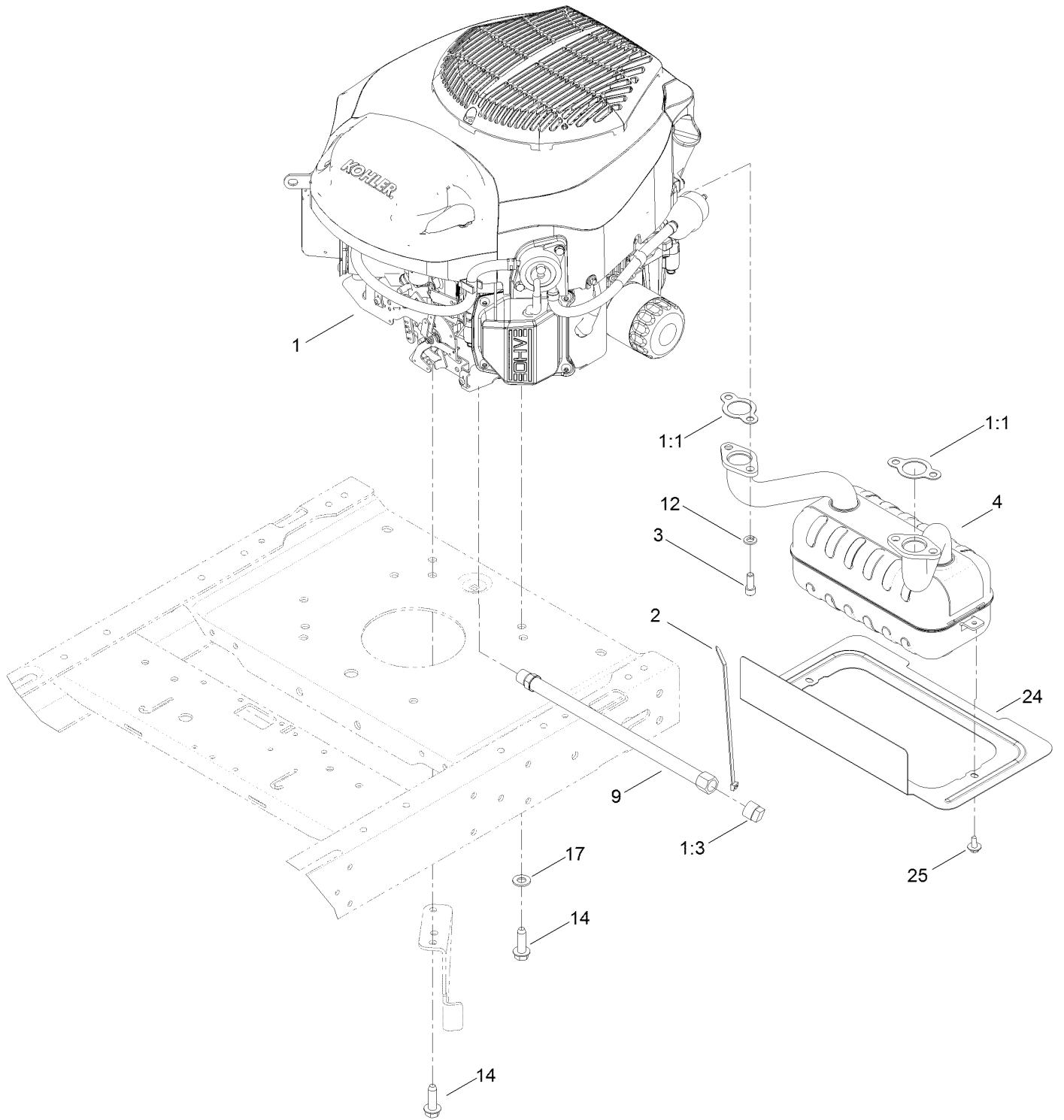

Engine and Muffler Assembly (continued)

<i>Ref.</i>	<i>Part Number</i>	<i>Qty.</i>	<i>Description</i>	<i>Ref.</i>	<i>Part Number</i>	<i>Qty.</i>	<i>Description</i>
1		1	Engine-Kohler, Kt735-3026 ●■	9	117-1261	1	Oil Drain Hose ASM
1:1	110-6697	2	Gasket-Exhaust	12	3253-4	4	Washer-Lock
1:3	281-2	1	Plug-Pipe, SQH	14	32144-109	4	Screw-Taptite
2	614249	1	Tie-Cable	17	3256-24	3	Washer-Flat
3	3274-10	4	Screw-HSH	24	121-2973-03	1	Shield-Heat
4	117-7462	1	Muffler-Kohler	25	46-8560	2	Screw-HHFTF

● Not serviced separately

■ Obtain parts from www.kohlerplus.com

Clutch Assembly

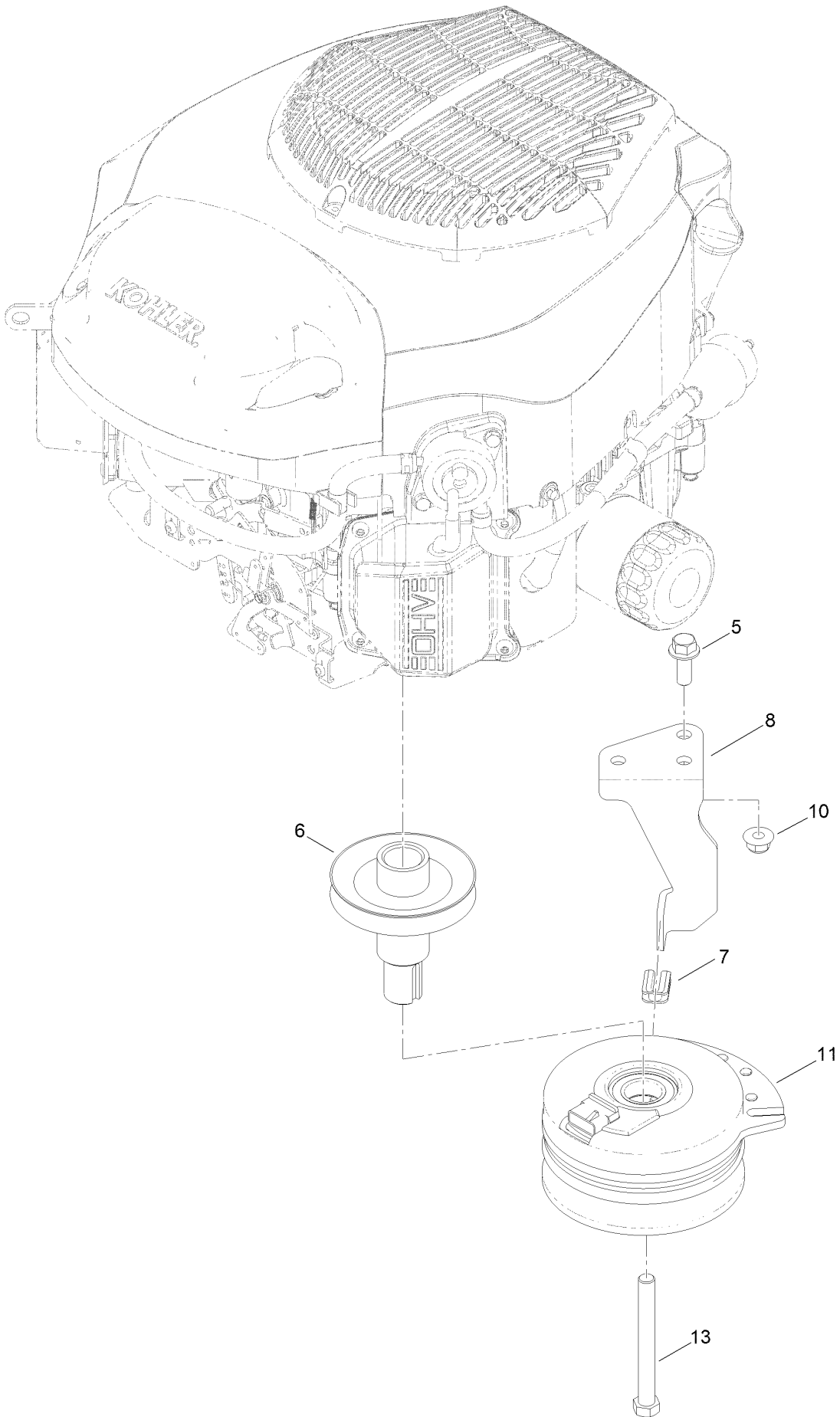

Clutch Assembly (continued)

<i>Ref.</i>	<i>Part Number</i>	<i>Qty.</i>	<i>Description</i>	<i>Ref.</i>	<i>Part Number</i>	<i>Qty.</i>	<i>Description</i>
5	3234-42	1	Screw-HHF	10	104-8301	1	Nut-Flange, NI
6	119-3318	1	Pulley-Engine	11	117-7468	1	Clutch-Electric
7	120-2217	1	Isolator-Clutch	13	3212-16	1	Screw-HH
8	119-8884	1	Stop-Clutch				

Hydro Transaxle Drive and Rear Wheel Assembly

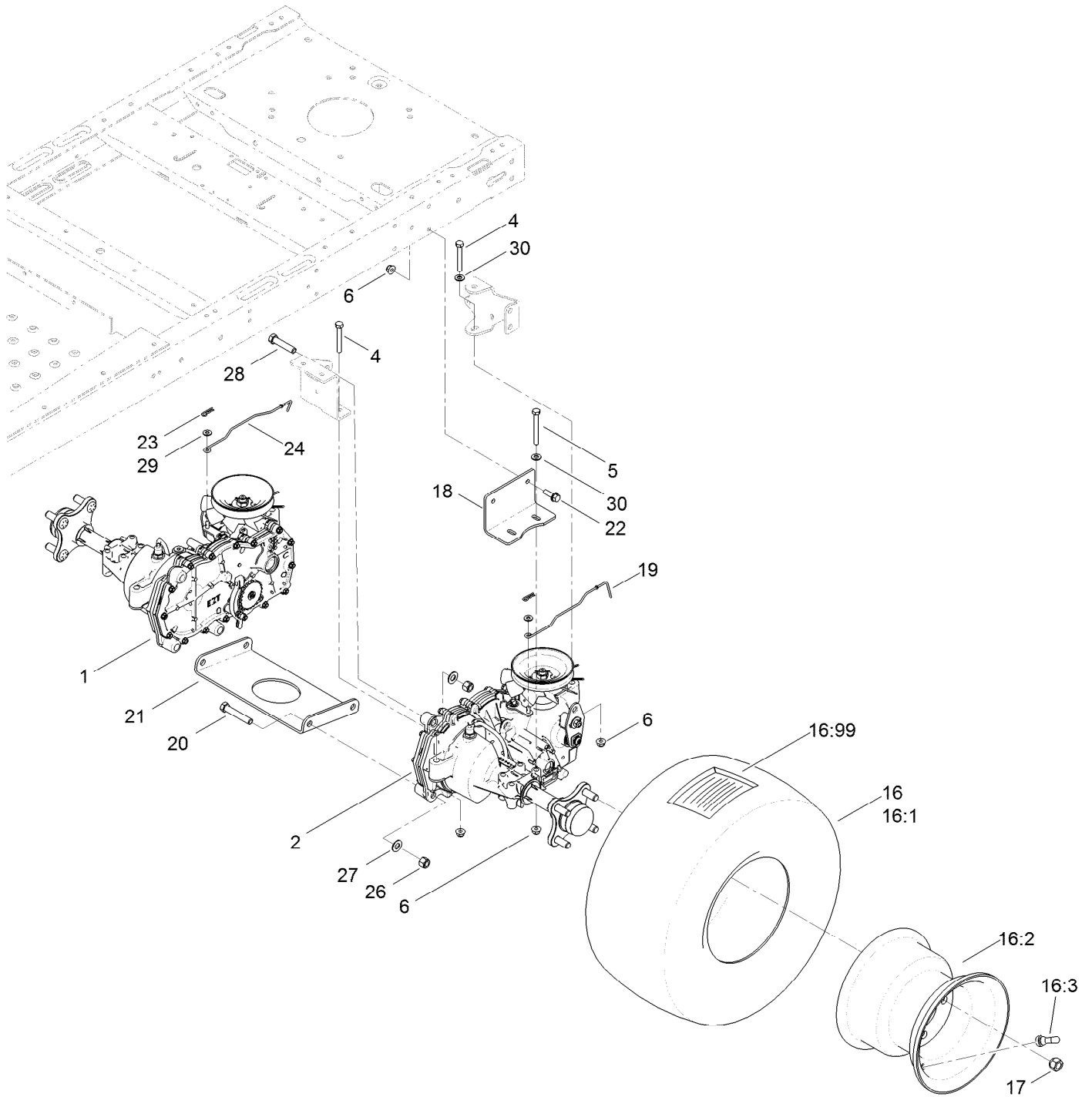

Hydro Transaxle Drive and Rear Wheel Assembly (continued)

<i>Ref.</i>	<i>Part Number</i>	<i>Qty.</i>	<i>Description</i>	<i>Ref.</i>	<i>Part Number</i>	<i>Qty.</i>	<i>Description</i>
1	119-3331	1	RH Hydro Transaxle ASM	19	121-2971	1	Rod-Bypass, LH
2	119-3330	1	LH Hydro Transaxle ASM	20	324-10	4	Screw-HH
4	322-11	4	Screw-HH	21	119-3339-03	1	Plate-Cross, Hydro
5	322-13	4	Screw-HH	22	3234-29	4	Screw-HHF
6	104-8300	12	Nut-Flange, NI	23	3290-307	2	Pin-Hair
16	120-5523	2	Wheel And Tire ASM	24	121-0752	1	Rod-Bypass, RH
16:1	119-8907	1	Tire	26	3296-48	6	Nut-Lock, NI
16:2	107-2475	1	Wheel	27	3256-25	6	Washer-Flat
16:3	232-27	1	Stem-Valve	28	324-8	2	Screw-HH
16:99	107-2491	1	Tube-Tire	29	119-8952	2	Washer
17	242-50	8	Nut-Lug	30	3256-23	6	Washer-Flat
18	117-7264-03	2	Mount-Hydro				

Left Hand Hydro Transaxle Assembly No. 119-3330

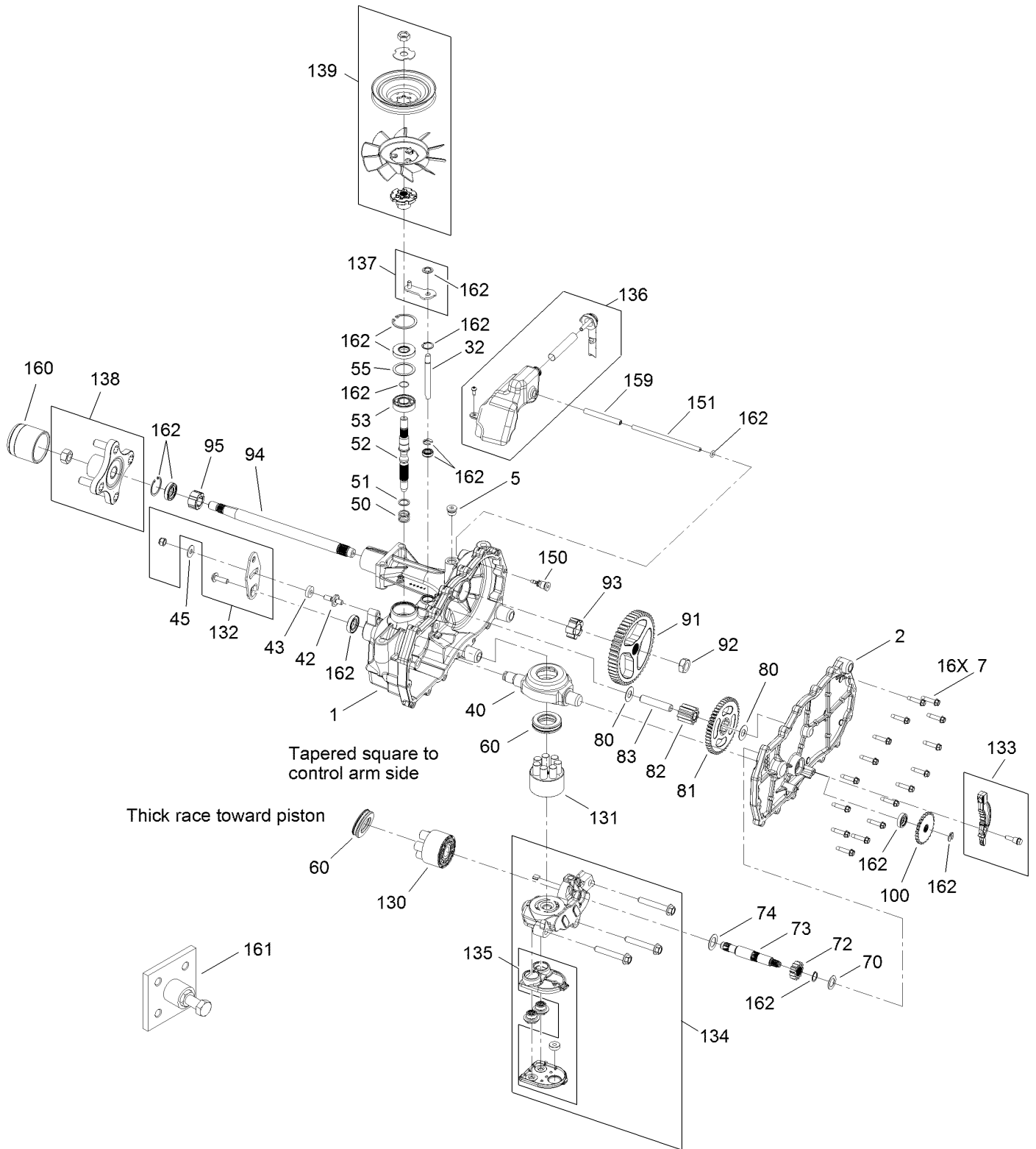

Left Hand Hydro Transaxle Assembly No. 119-3330 (continued)

<i>Ref.</i>	<i>Part Number</i>	<i>Qty.</i>	<i>Description</i>	<i>Ref.</i>	<i>Part Number</i>	<i>Qty.</i>	<i>Description</i>
1	120-5532	1	Main Housing ASM	83	104-5329	1	Pin-Jackshaft
2	120-5534	1	Housing Side Kit	91	120-5539	1	Gear-Bull
5	104-2189	1	Plug-Thread, Straight	92	104-2142	1	Nut-HJ
7	117-5359	16	Screw-HHF	93	115-8314	1	Bushing-Inboard
13	104-2147	1	Sealant ●	94	120-5540	1	Shaft-Axle
32	106-8678	2	Rod-Bypass	95	120-5541	1	Bearing-Sleeve
40	104-5304	1	Swashplate-Trunnion	100	106-8694	1	Disc-Brake, Cog
42	104-2116	1	Stud	130	103-2666	1	Cylinder Block Kit
43	112-9853	1	Puck-Friction	131	110-8561	1	Pump Block ASM
45	114-8491	1	Washer	132	117-5362	1	Arm Control Kit
50	120-5537	1	Spring-Compression	133	106-8688	1	Brake Arm Kit
51	120-5538	1	Washer	134	112-9861	1	Center Section Filter Kit
52	104-5306	1	Shaft-Input	135	114-1634	1	Filter Kit
53	104-5311	1	Bearing-Ball	136	121-5730	1	RH Expansion Tank Kit
55	104-5308	1	Spacer	137	120-5549	1	Bypass Kit
60	94-6922	1	Bearing-Thrust	138	121-5731	1	Hub Kit
70	104-5339	1	Washer-Flat	139	121-5729	1	Fan Pulley Kit
72	104-5316	1	Gear-Pinion, 13T	150	104-5349	1	Fitting-Sae
73	106-8683	1	Shaft-Motor	151	115-8302	1	Hose
74	104-5360	1	Washer	159	121-5728	1	Case-Tube
80	119-5541	2	Washer	160	125-0041	1	Cap-Axle
81	104-5317	1	Gear-10T/48T	161	114-8467	1	Hub-Puller, 4 Bolt
82	104-5318	1	Gear-Jackshaft, 10T	162	120-7103	1	Seal And Ring Kit

● Not illustrated

Right Hand Hydro Transaxle Assembly No. 119-3331

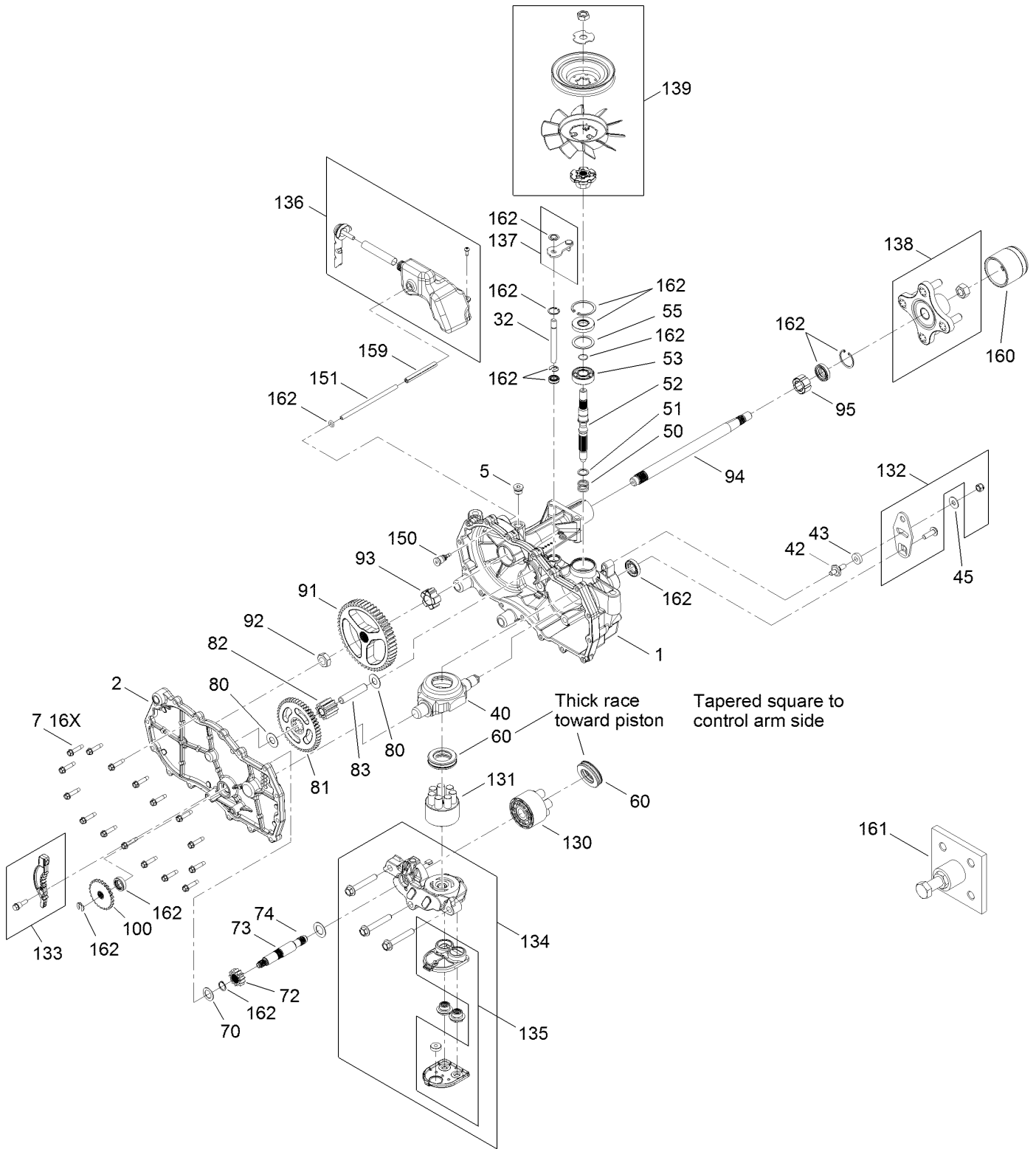

Right Hand Hydro Transaxle Assembly No. 119-3331 (continued)

<i>Ref.</i>	<i>Part Number</i>	<i>Qty.</i>	<i>Description</i>	<i>Ref.</i>	<i>Part Number</i>	<i>Qty.</i>	<i>Description</i>
1	120-5531	1	Main Housing ASM	83	104-5329	1	Pin-Jackshaft
2	120-5533	1	Housing Side Kit	91	120-5539	1	Gear-Bull
5	104-2189	1	Plug-Thread, Straight	92	104-2142	1	Nut-HJ
7	117-5359	16	Screw-HHF	93	115-8314	1	Bushing-Inboard
13	104-2147	1	Sealant ●	94	120-5540	1	Shaft-Axle
32	106-8678	2	Rod-Bypass	95	120-5541	1	Bearing-Sleeve
40	104-5304	1	Swashplate-Trunnion	100	106-8694	1	Disc-Brake, Cog
42	104-2116	1	Stud	130	103-2666	1	Cylinder Block Kit
43	112-9853	1	Puck-Friction	131	110-8561	1	Pump Block ASM
45	114-8491	1	Washer	132	117-5362	1	Arm Control Kit
50	120-5537	1	Spring-Compression	133	106-8688	1	Brake Arm Kit
51	120-5538	1	Washer	134	112-9862	1	Center Section Filter Kit
52	104-5306	1	Shaft-Input	135	114-1634	1	Filter Kit
53	104-5311	1	Bearing-Ball	136	121-5735	1	LH Expansion Tank Kit
55	104-5308	1	Spacer	137	107-2489	1	Bypass Arm Kit
60	94-6922	1	Bearing-Thrust	138	121-5731	1	Hub Kit
70	104-5339	1	Washer-Flat	139	121-5729	1	Fan Pulley Kit
72	104-5316	1	Gear-Pinion, 13T	150	104-5349	1	Fitting-Sae
73	106-8683	1	Shaft-Motor	151	115-8302	1	Hose
74	104-5360	1	Washer	159	121-5728	1	Case-Tube
80	119-5541	2	Washer	160	125-0041	1	Cap-Axle
81	104-5317	1	Gear-10T/48T	161	114-8467	1	Hub-Puller, 4 Bolt
82	104-5318	1	Gear-Jackshaft, 10T	162	120-7103	1	Seal And Ring Kit

● Not illustrated

Belt and Idler Assembly

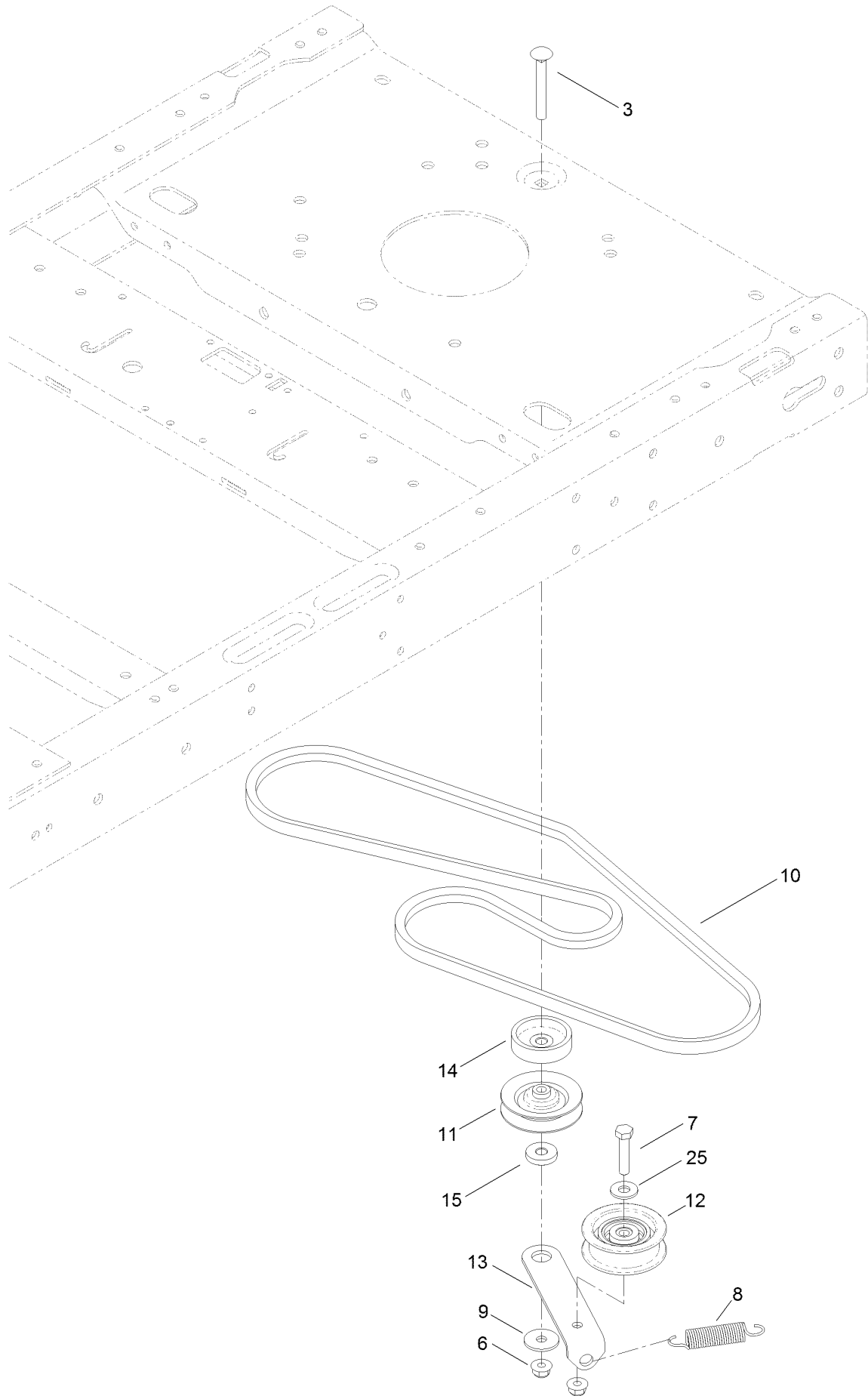

Belt and Idler Assembly (continued)

<i>Ref.</i>	<i>Part Number</i>	<i>Qty.</i>	<i>Description</i>	<i>Ref.</i>	<i>Part Number</i>	<i>Qty.</i>	<i>Description</i>
3	3230-8	1	Screw-CARR	11	119-8822	1	Pulley-Idler
6	104-8300	2	Nut-Flange, NI	12	106-2176	1	Pulley-Idler
7	322-7	1	Screw-HH	13	119-3326	1	Arm-Idler
8	104-6415	1	Spring-Return, Pedal	14	119-3353	1	Spacer
9	5-4460	1	Washer-Pivot	15	119-3327	1	Spacer-Arm, Idler
10	119-3309	1	V-Belt	25	3256-3	1	Washer-Flat

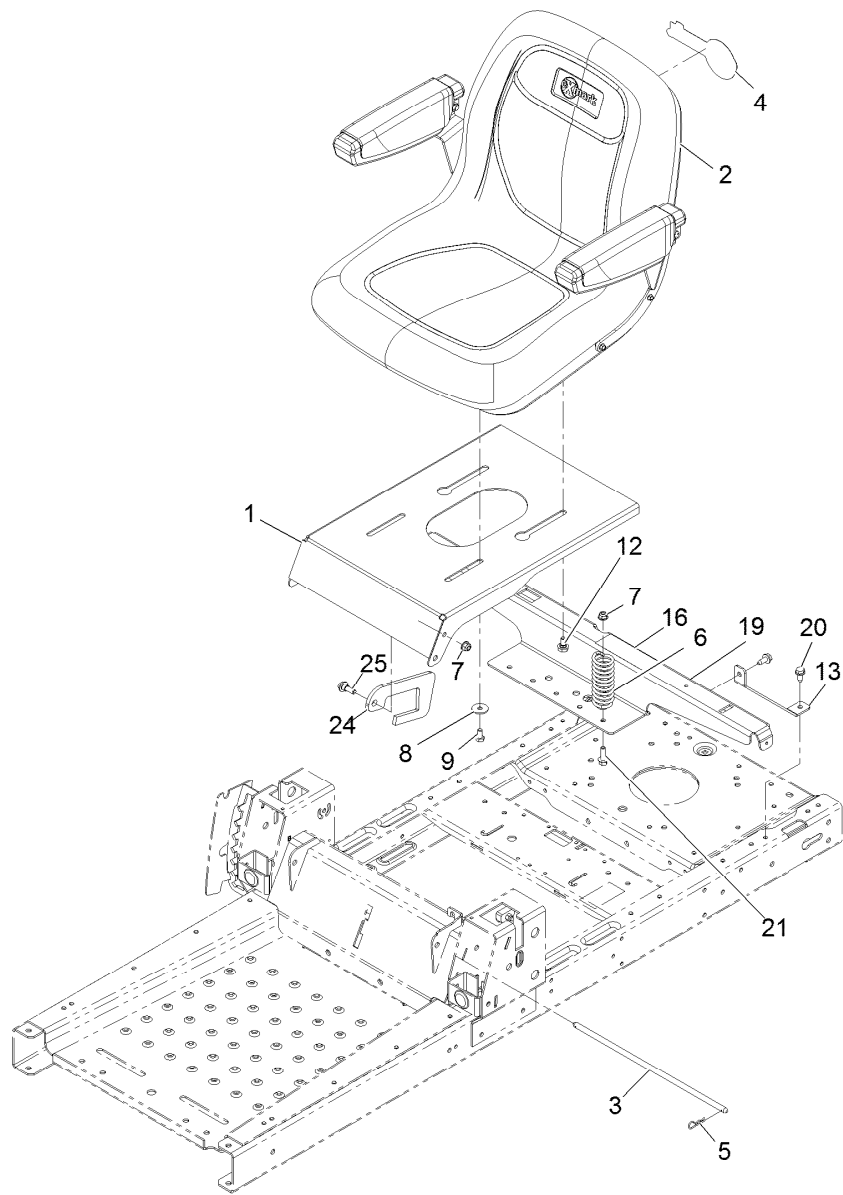

Seat Assembly

<i>Ref.</i>	<i>Part Number</i>	<i>Qty.</i>	<i>Description</i>	<i>Ref.</i>	<i>Part Number</i>	<i>Qty.</i>	<i>Description</i>
1	119-3391-03	1	Pan-Seat	13	119-3431-03	2	Support-Tank, Rear
2	119-8957	1	Seat-18 In W/Arm	16	106-8717	1	Decal-Service
3	119-3433	1	Rod-Pivot, Narrow	19	121-0732-03	1	Support-Pod
4	120-5464	1	Decal	20	32144-70	4	Screw-HWH 5/16-18 X 3/4 Tf
5	3290-250	2	Pin-Hair	21	3234-29	3	Screw-HH Flg 5/16-18 X 1
6	92-7054	3	Spring-Compression	24	120-5512	1	Stop-Seat
7	104-8300	4	Nut-Nyloc 5/16-18 Flg	25	116-2670	1	Screw-Shoulder HHF 5/16-18 X .96
8	5-4460	2	Washer-Pivot				
9	322-2	2	Screw-HH 5/16-18 X 5/8				
12	37-8771	2	Screw-Shoulder 5/16-18 X 5/8				

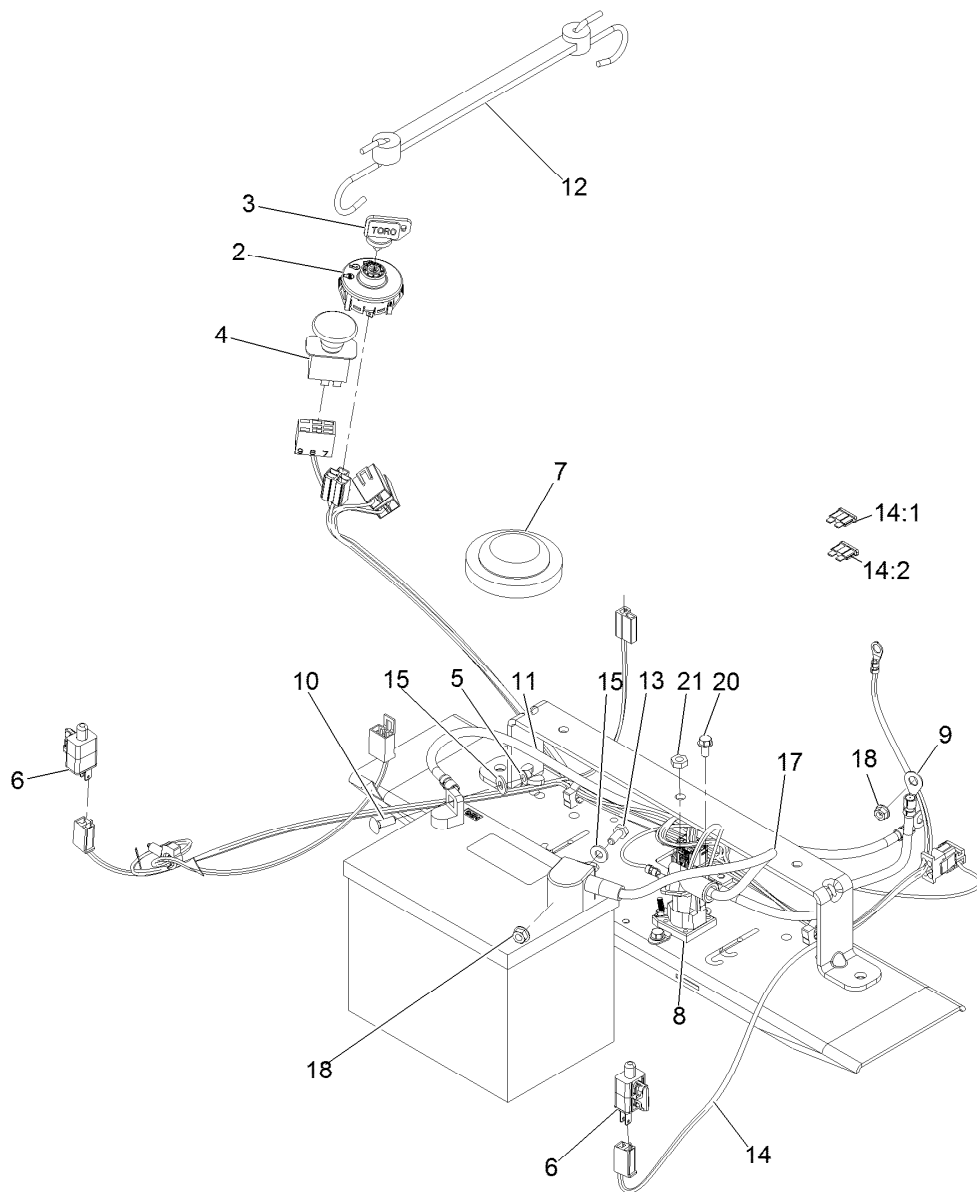

Electrical Assembly

<i>Ref.</i>	<i>Part Number</i>	<i>Qty.</i>	<i>Description</i>	<i>Ref.</i>	<i>Part Number</i>	<i>Qty.</i>	<i>Description</i>
2	117-2221	1	Switch-Ignition	13	321-3	1	Screw-HH 1/4-20 X 5/8
3	103-2106	1	Key-Exmark Logo	14	121-5652	1	Harness-Wire
4	103-5221	1	Switch-PTO	14:1	109103	1	Fuse-Blade, 30 Amp
5	32103-22	1	Nut-Wing	14:2	109102	1	Fuse-Blade, 25 Amp
6	110-6765	2	Switch	15	3256-22	2	Washer-1/4 Sae
7	100-3524	1	Switch-Seat	17	119-8897	1	Cable-Battery, Red
8	117-1197	1	Solenoid	18	32128-33	2	Nut-Whizlock 1/4-20
9	121-0711	1	Cable-Battery, Positive	20	32144-4	2	Screw-HWH 1/4-20 X 1/2 Taptite
10	3229-1	1	Bolt-Carriage 1/4-20 X 3/4	21	3220-2	2	Nut-Jam 5/16-24
11	121-5726	1	Cable-Battery, Black				
12	104-2466	1	Holddown-Battery				

Notes:

MAXIMIZE THE PERFORMANCE OF YOUR EXMARK.

4-CYCLE PREMIUM ENGINE OIL

Part No. 116-3373

Both SAE 30 and SAE 10W-30 in one bottle.

Contains increased levels of zinc and phosphorus for better lubricity.

No Viscosity Index Improvers that tend to shear down in high heat.

Synthetic formulation.

Gas & Diesel compatible.

Anti-corrosion additives.

API 'SL' and JASO rated with wet clutch compatibility for other machines.

PREMIUM HYDRO OIL

Part No. 109-9828

Commercial quality for tough, high-heat conditions.

Designed specifically for zero-turn mower hydraulic systems.

Superior shear resistance under heavy loads.

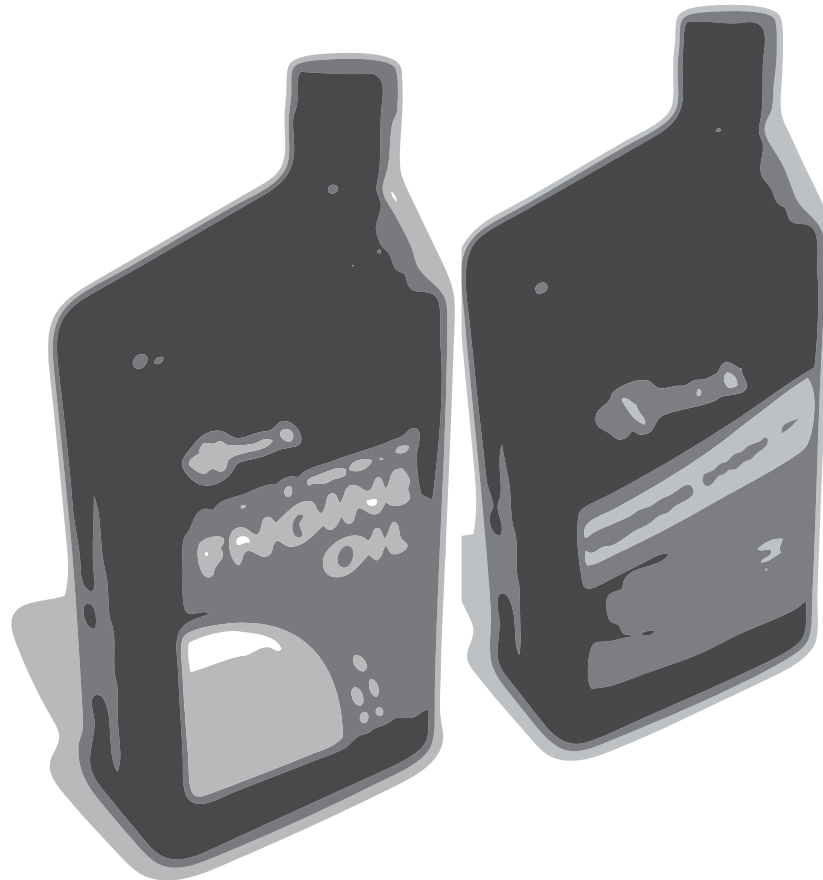

Available from your local Exmark dealer. Find your closest dealer at exmark.com

EXMARK ACCESSORIES AND OPTIONS*

MID-MOUNT RIDING ACCESSORIES AND OPTIONS

CUSTOM RIDE SEAT SUSPENSION SYSTEM	OPERATOR CONTROLLED DISCHARGE
FULL SUSPENSION SEAT	SUN SHADE
DECK LIFT ASSIST KIT	TRASH CONTAINER
HITCH KIT	TURF STRIPER
LIGHT KIT	ULTRA VAC COLLECTION SYSTEM
12V POWER PORT	ULTRA VAC QUICK DISPOSAL SYSTEM
MICRO-MULCH SYSTEM	

OUT-FRONT RIDING ACCESSORIES AND OPTIONS

CUSTOM RIDE SEAT SUSPENSION SYSTEM	SNOW BLADE
DUAL-TAIL WHEEL	SNOWBLOWER
FLOOR PAN EXTENDER	SUN SHADE
HITCH KIT	TRASH CONTAINER
LIGHT KIT	ULTRA VAC COLLECTION SYSTEM
MICRO-MULCH SYSTEM	ULTRA VAC QUICK DISPOSAL SYSTEM
ROLL OVER PROTECTION SYSTEM (ROPS)	WEATHER CAB

WALK-BEHIND ACCESSORIES AND OPTIONS

GRASS CATCHER	TURF STRIPER
MICRO-MULCH SYSTEM	STANDON

*Some accessories and options not available for some models.

Place Model No. and Serial No.
Label Here (Included in the Literature
Pack) or Fill in Below

Model No. _____

Serial No. _____

Date Purchased _____

Engine Model No. and Spec. No. _____

Engine Serial No. (E/No) _____

© 2014 Exmark Mfg. Co., Inc.
Industrial Park Box 808
Beatrice, NE 68310
All Rights Reserved

Part No. 4501-984 Rev. A
(402) 223-6290
Fax (402) 223-5489
Printed in the USA.

