



Count on it.

Operator's Manual

**Pro Control™ XP Spray System
Multi-Pro® 5800 Turf Sprayer**

Model No. 41604—Serial No. 311000476 and Up



Introduction

⚠ WARNING

CALIFORNIA Proposition 65 Warning

This product contains a chemical or chemicals known to the State of California to cause cancer, birth defects, or reproductive harm.

Read this manual carefully to learn how to operate and maintain your product properly. The information in this manual can help you and others avoid injury and product damage. Although Toro designs and produces safe products, you are responsible for operating the product properly and safely. You may contact Toro directly at www.Toro.com for product and accessory information, help finding a dealer, or to register your product.

Note: If you are installing this kit (the Pro Control XP Spray System Kit) along with one or more other kits, such as the Educator Kit (model 41612), the Electric Hose Reel Kit (model 41613), or the Tank Rinse Kit (41614), we recommend that you assemble the kits into the manifold valve assembly at the same time.

Whenever you need service, genuine Toro parts, or additional information, contact an Authorized Service Dealer or Toro Customer Service and have the model and serial numbers of your product ready. Figure 1 illustrates the location of the model and serial numbers on the product.

Model No. _____
Serial No. _____

This manual identifies potential hazards and has safety messages identified by the safety alert symbol (Figure 1), which signals a hazard that may cause serious injury or death if you do not follow the recommended precautions.



Figure 1

1. Safety alert symbol.

This manual uses 2 words to highlight information. **Important** calls attention to special mechanical information

and **Note** emphasizes general information worthy of special attention.

Contents

Introduction	2
Safety	3
Setup	4
1 Installing the Console Computer	4
2 Installing the Flowmeter	5
Product Overview	7
Controls	7
Operation	9
Initially Programming the Console Computer	9
Displaying Data	10
Self-Testing the Console Computer	10
Activating the Data Lock	10
Changing the Data Lock	10
Entering the Mode Sequence with the Data Lock Activated	10
Setting the Power Down Delay Time	11
Using the Console Computer Alarm	11
Setting Up the System	11
Initially Field-testing the System	11
Maintenance	13
Recommended Maintenance Schedule(s)	13
Cleaning the Flowmeter	13
Programming the Console Computer	13
Calibrating the Flowmeter	15
Testing the Flowmeter Cable	15
Troubleshooting	16

Safety

Read and understand the contents of this manual before operating the console computer.

- Keep this document with the *Operator's Manual* for the Multi Pro® 5800 Turf Sprayer.
- It is very important that all who operate this equipment have ready access to these instructions at all times.
- Read these instructions and the instructions in the *Operator's Manual* for the Multi Pro® 5800 Turf Sprayer carefully. Be familiar with the controls and the proper use of the equipment.
- Never allow children or people unfamiliar with these instructions to use the controls.
- Never spray while people, especially children, or pets are nearby.
- Chemicals can injure people, animals, plants, soils, or other property. To avoid personal injury and environmental damage:
 - Select the proper chemicals for the job.
 - Follow the manufacturer's instructions on the chemical container labels. Apply and handle chemicals as recommended.
 - Handle and apply the chemicals with care.
 - Wear all necessary protective equipment.
 - Handle chemicals in well-ventilated areas.
 - Never smoke when handling chemicals.
 - Properly dispose of unused chemicals and containers.
- Keep in mind that the operator or user is responsible for accidents or hazards occurring to other people or for damage to property.

Installation

Loose Parts

Use the chart below to verify that all parts have been shipped.

Procedure	Description	Qty.	Use
1	Mounting bracket	1	Install the console computer.
	Carriage bolt (5/16 x 3/4 inch)	3	
	Locknut (5/16 inch)	3	
	Computer console assembly	1	
	Hand Knob	2	
2	Flowmeter	1	Install the flowmeter.
	Gasket	1	
	Hose clamp, worm screw	1	

1

Installing the Console Computer

Parts needed for this procedure:

1	Mounting bracket
3	Carriage bolt (5/16 x 3/4 inch)
3	Locknut (5/16 inch)
1	Computer console assembly
2	Hand Knob

Installing the Console Computer

1. Install the mounting bracket to the dashboard and secure it with 2 carriage bolts (5/16 x 3/4 inch) and 2 locknuts (5/16 inch) as shown in Figure 2.

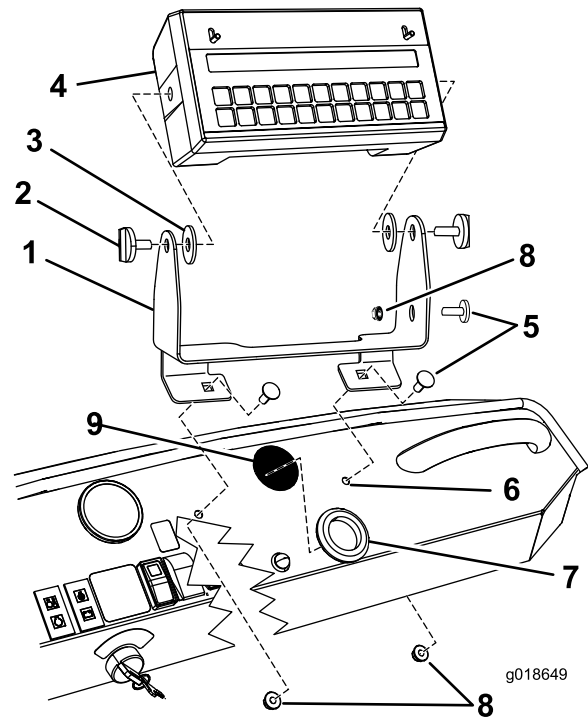

Figure 2

- | | |
|------------------------------------|---|
| 1. Mounting bracket | 6. Mounting hole in dashboard, existing |
| 2. Hand knob (2) | 7. Large grommet |
| 3. Rubber washer (2) | 8. Locknuts (5/16 inch) |
| 4. Console computer | 9. Knocked-out hole in dash |
| 5. Carriage bolt (5/16 x 3/4 inch) | |

2. Locate the round, multi-pin console computer connectors on the main harness secured to the right frame member under the dashboard.
3. Cut the plastic tie that secures the console computer wiring to the frame under the dashboard.
4. Remove the 2 protective caps from the cable ends.

- Route the console computer cables from under the dashboard through the hole with the large grommet.
- Plug the cables into their corresponding inputs on the rear of the console computer (Figure 3), and secure the cables by rotating the locking rings.

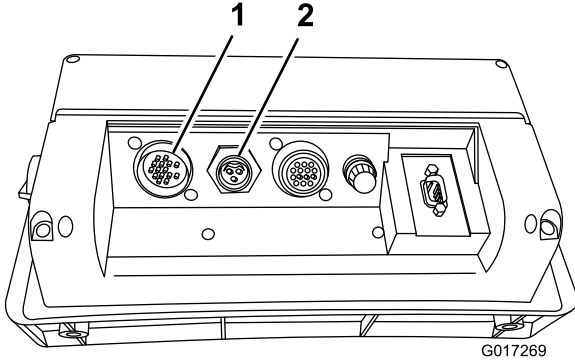

Figure 3
Rear of console computer

- Flowmeter cable connection
- Speed sensor cable connection

- Assemble the computer console to the mounting bracket with 2 hand knobs (Figure 2).
- Adjust the pivot angle of the console face to the desired position, and tighten the hand knobs on either side console to secure the position.

2

Installing the Flowmeter

Parts needed for this procedure:

1	Flowmeter
1	Gasket
1	Hose clamp, worm screw

Procedure

Move to the rear of the machine and locate the boom-valve-assembly on the boom-valve mounting bracket.

- Loosen, but do not remove, the bolts that secure the boom-valve-assembly to the mounting bracket (Figure 4).

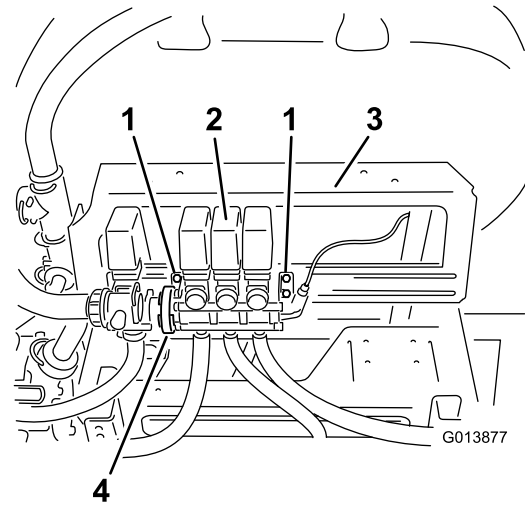

Figure 4

- Bolts
- Boom-valve-assembly
- Boom mount
- Worm clamp

- Loosen the existing worm clamp that secures the agitation valve to the boom-valve-assembly (Figure 4).
- Carefully move the boom-valve-assembly away from the agitation valve (Figure 5).

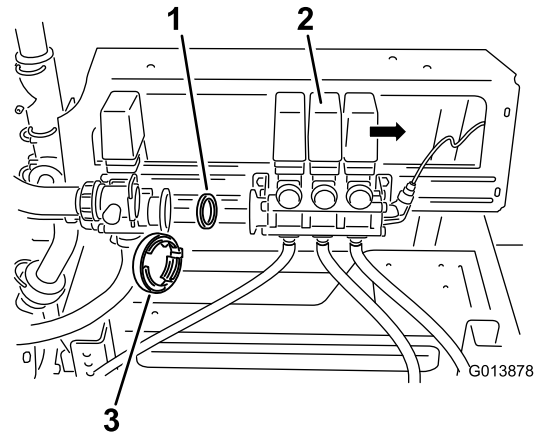

Figure 5

- Gasket
- Boom-valve-assembly
- Worm clamp

- Remove the existing gasket in the valve body (Figure 5).

Note: Retain both the clamp and gasket.

- Locate the flowmeter, gasket, and worm clamp in loose parts.
- Install the flowmeter in-line between the agitation and boom valve assemblies with the flow arrow pointing toward the 3 boom valves (Figure 6).

Note: Ensure that both gaskets are properly installed.

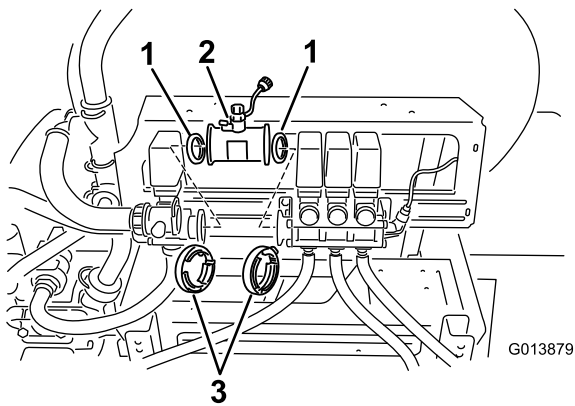

Figure 6

- | | |
|--------------|----------------|
| 1. Gasket | 3. Worm clamps |
| 2. Flowmeter | |

- A. Install the existing gasket into the flowmeter side that will mate with the agitation valve (Figure 6).
- B. Install the existing worm clamp over the flowmeter.
- C. Move the flowmeter into position flush with the agitation valve body.

Note: Secure the flowmeter to the agitation valve body by tightening the clamp.

- D. Install the new gasket into the open side of the flowmeter body.
- E. Install the new worm clamp over the open end of the flowmeter.
- F. Carefully move the boom-valve-assembly into the position flush with the flowmeter body (Figure 7).

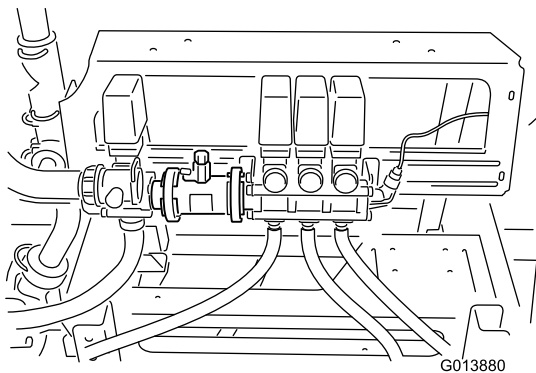

Figure 7

- G. Secure the flowmeter to the boom-valve-assembly by tightening the clamp.
7. Tighten the bolts that secure the boom bypass valve assembly to the mounting bracket.
8. Locate the spray system wiring harness routed to the boom valve manifold.
9. Locate the capped round flowmeter connector.
10. Remove the cap to expose the 3-pin plug and connect it to the wire coming from the flowmeter.

11. Secure the locking rings if available.
12. Inspect all work to ensure that all hose clamps are tightened.
13. Close bypass valves by rotating the red bypass knobs clockwise until a slight resistance is felt, indicating the valve is completely closed.

Note: The knob may require 3 to 4 rotations (360=1 rotation) to completely close.

Note: The numbers printed on the bypass knob are for reference only. Setting the knob to “0” does not ensure the valve is closed. You must continue turning the knob until you feel rotational resistance—this is your indication that the valve is closed.

Product Overview

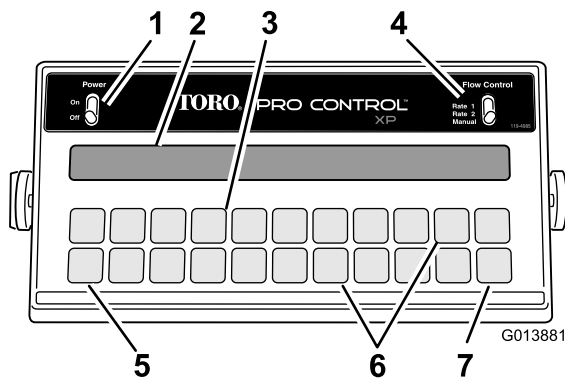

Figure 8

- | | |
|------------------------|------------------|
| 1. Power switch | 5. CE key |
| 2. Display | 6. Function keys |
| 3. Calibration keys | 7. Enter key |
| 4. Flow-control switch | |

Controls

The ProControl™ System consists of a computer-based control console, a speed sensor, and a turbine-type flowmeter.

Become familiar with the controls (Figure 8) before you start the engine and operate the sprayer.

Power switch

This switch turns the console power on and off. Turning off the console computer does not affect the data stored in the computer.

The Console keys

The keypad for the console computer is shown in Figure 9.

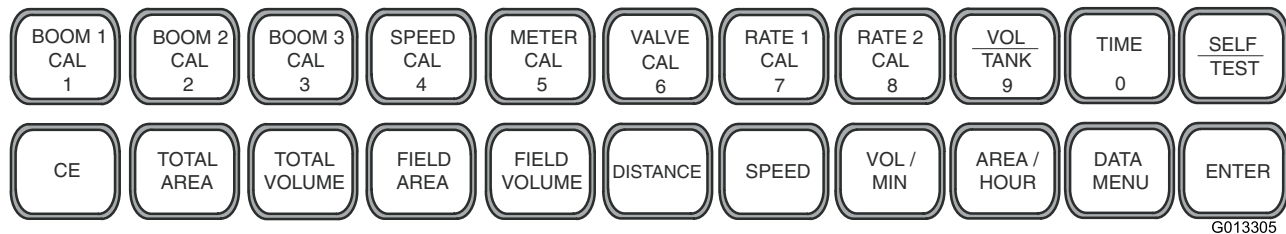

Figure 9

Flow-control switch

This switch allows you to automatically or manually control the spray system. There are 2 automatic positions and 1 manual position.

Display

The display shows the function and calibration data.

Calibration keys

These keys allow the operator to enter data into the console computer to calibrate the spray system.

Function keys

These keys display needed data, such as the total area sprayed, the total volume of material sprayed, the vehicle speed, and the volume of material remaining in the tank.

Enter key

This key allows you to enter data into the console computer.

CE key

This key clears the data shown in the display; it also enables you to toggle through the options found in certain function keys.

The console computer allows the following parameters: Area: US (acres); SI (hectares) or TU (1000 ft²).

Keypad Reference Table

Key	Description	Function*
BOOM 1 CAL (1)	Length of boom 1	It calculates the length of the boom by multiplying the number of nozzles by the spacing between them in inches (cm) of the left boom. 80 inches (204 cm) is set as the default.
BOOM 2 CAL (2)	Length of boom 2	It calculates the length of the boom by multiplying the number of nozzles by the spacing between them in inches (cm) of the center boom. 60 inches (152 cm) is set as the default.
BOOM 3 CAL (3)	Length of boom 2	It calculates the length of the boom by multiplying the number of nozzles by the spacing between them in inches (cm) of the right boom. 80 inches (204 cm) is set as the default.
SPEED CAL (4)	Speed calibration number	148 (US or TU) or 38 (SI) is set as the starting point for all Toro sprayers.
METER CAL (5)	Flowmeter calibration number	Enter the number found on the flowmeter label or the tag on the flowmeter cable (Gal# for US or TU, or Liter# for SI).
VALVE CAL (6)	Control valve response time	It sets the system response. Enter 23 is set as the starting point.
RATE 1 CAL (7)	Target application rate 1	It is the first application rate.
RATE 2 CAL (8)	Target application rate 2	It is the second application rate. If there is only one application rate, use the Rate 1 value again.
VOL / TANK (9)	Volume of material remaining in the tank	It displays the volume of material in the sprayer tank. Reset the volume when you refill the tank.
TIME (0)	24-hour clock	It is a 24-hour clock or an elapsed timer. You reset it when you turn off the console computer.
SELF TEST (←)	Simulation of vehicle speed	It is used to simulate the vehicle speed to allow the operator to check and calibrate the system operation while the vehicle is stationary.
CE	Clear Entry	It clears a wrong entry; enables you to toggle between settings during initial programming; and enables you to select functions and settings.
TOTAL AREA	Total area sprayed	It monitors the total area covered until you clear it to zero.
TOTAL VOLUME	Total volume of material sprayed	It monitors the volume of material sprayed until you clear it to zero.
FIELD AREA	Field area sprayed	It monitors the total area covered until you clear it to zero.
FIELD VOLUME	Volume of material sprayed onto a field or specific area	It monitors the volume of material applied until you clear it to zero.
DISTANCE	Distance of vehicle travel	It measures the distance the vehicle travels until you clear it to zero.
SPEED	Vehicle speed	It displays the vehicle speed.
VOL / MIN	Volume of material sprayed per minute at vehicle speed	It displays the volume/minute that the system is currently using.
AREA / HOUR	Area sprayed per hour at vehicle speed	It displays acres, 1000 sq. ft., or hectares covered per hour at the vehicle speed driven.
DATA MENU	Area sprayed per hour at vehicle speed. Preset agitation can be selected by pressing the Data Menu until Preset Agitation is displayed.	This allows you to adjust agitation pressure when the booms are off. The setting is preset at 105. Note: When the number increases, the agitation pressure increases. The number is not the agitation pressure.
ENTER	Enter data	It allows you to enter data into the console computer.

*The calibration numbers listed are **for reference only**. Before spraying, check your sprayer to ensure that the numbers you are using are correct.

Operation

The console computer automatically controls the spray application rate for varying vehicle speeds. You set the target volume per unit area to spray and the console computer automatically maintains the flow within the proper range of the vehicle speed and continually displays the actual volume of material per area sprayed. The console computer also monitors the area sprayed, the speed of the vehicle, and the total volume of material sprayed.

Important: A manual override switch allows the operator to manually control the flow for system inspection and spot spraying.

Note: If the console computer malfunctions, you can spray manually by unplugging the cables from the rear of the console computer. You can then control the spray application rate using the center console controls.

In this section, the procedure will use the following naming convention:

- The labels on the console computer keys are enclosed in brackets. For example: Press the [Enter] key.
- The data you enter is in boldface type preceded by the word **Press**. For example: Press **123**.
- The data shown in the display is in normal type, with letters in all caps.

Initially Programming the Console Computer

You must first program the console computer before you can use it to operate the spray system. You need to perform this operation only when you turn on the console computer for the first time.

Turn the power switch to the On position.

Note: The console screen shows the message CAL in the display.

Selecting US, SI, or TU

To select the units for US (volume per acre), SI (volume per hectare), or TU (volume per 1,000 sq. ft.):

1. Press the [CE] key until you see your desired code (US, SI, TU) in the display.
2. Press the [Enter] key.

Note: If you make a data entry error, reset the console computer by turning the power switch to the Off position and, while pressing and holding the [CE] key, turning the power switch to the On position.

Entering the Meter Cal Number

Use the gallon calibration number for US gallons per acre or US gallons per 1000 sq. ft. or a liter calibration number for liters per hectare.

1. Press the [Meter Cal] key.
2. Press the [Enter] key.
3. Enter the Meter Cal calibration number.

Note: The Meter Cal (or flowmeter) calibration number is stamped on the tag attached to the flowmeter or meter cable (Figure 10).

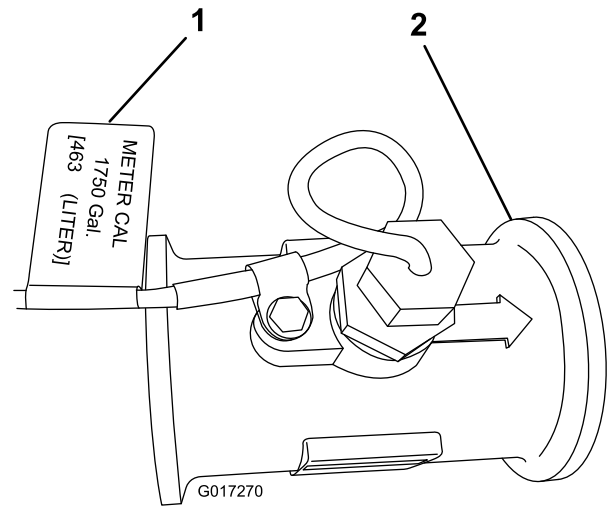

Figure 10

1. Tag
2. Flowmeter

4. Press the [Enter] key.

Entering Rate 1 and Rate 2 Data

Enter the spray application rate (with decimal) in Rate 1 and Rate 2. Enter the rates in US gallons per acre (US mode), US gallons per 1,000 square feet (TU mode), or liters per hectare (SI mode) depending on the base measurement you select.

1. Press the [Rate 1 Cal] key.
2. Press the [Enter] key.
3. Enter the target application rate (in gal. per acre, liters per hectare, or US gallons per 1,000 sq. feet) that you want to spray.
4. Press the [Enter] key.
5. Press the [Rate 2 Cal] key.
6. Press the [Enter] key.
7. Enter a second target application rate (in US gallons per acre, liters per hectare, or US gallons per 1,000 sq. ft.) that you want to spray, if you desire.

Note: Rate 2 should not differ more than 20% from Rate 1 unless there is a change in nozzle size. If you do not use a second rate, enter the same rate for Rate 1 and Rate 2.

8. Press the [Enter] key.

Note: You have now completed programming the console computer. The flashing CAL in the display should stop. If not, repeat the procedures for programming the console computer.

Displaying Data

To display the following data, do the following:

Total Area

Press the [Total Area] key.

Total Volume

Press the [Total Volume] key.

Note: To change the total volume to 0: press the [Enter] key, then 0, then press the [Enter] key again.

Field Area

Press the [Field Area] key.

Field Volume

Press the [Field Volume] key.

Note: To change the field volume to 0: press the [Enter] key, then 0, then press the [Enter] key again.

Distance

Press the [Distance] key.

Note: The distance is displayed in meters or feet. To change the total distance to 0: press the [Enter] key, then 0, then press the [Enter] key again.

Speed

Press the [Speed] key.

Vol/Min

Press the [Vol/Min] key.

Area/Hour

Press the [Area/Hr] key.

US, SI, or TU

1. Press and hold the [Self Test] key.
2. Press the [Total Area] key.

Note: These parameters will alternately appear on the display.

Data Menu

This allows you to adjust agitation pressure when the booms are off. Start with the setting of 95. Press the [Data Menu] key once, preset agitation will display. Press the [Enter] key, then 95, then the [Enter] key again.

Note: Do not change the other values for the PWM (pulse width modulation); they are preset for the system.

Self-Testing the Console Computer

The self test allows you to simulate the speed for testing the system when the vehicle is not moving.

1. Press the [Self Test] key.
2. Press the [Enter] key.
3. Enter the speed in mph or km/h.
4. Press the [Enter] key.
5. Press the [Speed] key to verify the speed.
The speed shows in the display.

Note: The self test speed will clear itself when the speed sensor detects that the vehicle is moving or when the controller is turned off.

Activating the Data Lock

This is an optional feature that prohibits users from entering data without first entering the data lock code.

1. Press [Data Menu] several times until you see PRESS ENTER FOR DATA LOCK on the display.
2. Enter a 4-digit code and press the [Enter] key within 15 seconds.

Changing the Data Lock

1. Press the [Data Menu] key several times until you see the PRESS ENTER FOR DATA LOCK in the display.
2. Press the [Enter] key.
Note: The display shows OLD CODE E.
3. Enter a 4-digit code and press the [Enter] key within 15 seconds.
4. Press the [Enter] key.

Entering the Mode Sequence with the Data Lock Activated

1. Press the key in which you wish to enter day.
2. Press the [Enter] key.
The display shows CODE.
3. Enter your data lock code.
If the code is correct, the display will show an E.
4. Enter your data as you normally do.

Note: You may clear the data lock code by entering a code of 0 or by resetting the console. Set the power switch to the Off position and hold the [CE] key down while you set the power switch to the On position to reset the console.

Setting the Power Down Delay Time

To conserve the 12-volt battery on the vehicle, set the power down delay. In this power down mode, all the data is retained but the time of day clock does not operate. The power down day is initially set to 10 days.

1. Press the [Time] key 5 times.
The display shows POWER DOWN DAY.
2. Press the [Enter] key.
3. Change the power down day setting.
4. Press the [Enter] key.

Using the Console Computer Alarm

This is an optional feature.

The console alarm sounds if the application rate is 30% or more away from the target application rate for 5 seconds.

1. Press the [Data Menu] key several times.
The display shows ALARM ON. The alarm is enabled.
2. Press the [CE] key.
The display shows ALARM OFF. The alarm is disabled.

Setting Up the System

Before operating the spray system, perform this procedure.

1. Read through the following instructions before starting.
2. Attach the supply hose to the anti-siphon tube and fill the tank half full of clean water.
Important: Inspect and clean all system components before spraying, including the tank, strainer, pump, valves, and nozzles.
3. Start the engine; refer to the *Operator's Manual* for the Multi-Pro® 5800 Turf Sprayer.
4. Move the throttle lever to the maximum setting.
5. Turn the Boom On/Off switches to the Off position.
6. Turn the Man/Rate switch to Man.
7. Turn the Power On/Off switch to the On position.
8. Turn the Spray Pump Control switch to the On position.
9. Ensure that you have entered the proper values for the correct boom width and calibrations for Meter Cal, Rate 1, and Rate 2.
10. Use the self-test feature as described in the *Operator's Manual* for the Multi-Pro 5800 Turf Sprayer for testing the spray system while the vehicle is not moving.

Note: The self-test feature simulates speed so that the system may be tested without moving. This feature

will clear itself when the speed sensor detects that the vehicle is in motion. A speed calibration value greater than or equal to 900 (US or TU) or 230 (SI) is recommended when operating in this mode.

To set the self-test feature, do the following:

Note: To prevent the self-test speed from clearing itself out automatically, disconnect the speed connector on the back of the console when radar speed sensors are used.

- A. Press the SELF TEST button.
- B. Enter the desired simulated speed value.
- C. Verify the vehicle's speed by pressing the SPEED button.

11. Turn the Boom switches to the On position.

Note: If the switch lights don't turn on, the foot switch is off. Turn the foot switch to the On position.

12. Use the Pressure Adjust switch to increase the pressure to 20 psi, then decrease it back to 0 psi.

13. Turn the Man/Rate switch to Rate 1.

Note: The pump should increase the pressure until it reaches the desired rate with the proper nozzle size.

14. Turn the Master Boom Control (foot) switch to the Off position.

15. Turn the Agitation switch to the On position.

Note: The system starts the pump and increases the pump speed until the pump reaches the preset agitation pressure. The system goes to this pressure when the booms are off and the pump and agitation are on.

For the initial system setting, note the pressure on the pressure gauge. Turn the agitation bypass valve to the same pressure as it was before. If you want to reduce the agitation or increase the supply to the boom for large application rates, you can also partially close the agitation ball valve.

16. Turn the agitation switch and the pump switch to the Off position.

Initially Field-testing the System

Before operating the spray system, perform this procedure.

1. Drive the vehicle at the desired spraying speed with the sprayer booms off.
2. Press the [Speed] key to verify the speed readout.
3. Turn the Spray pump control switch to On.
4. Turn the Pro Control XP Power switch to the On position.
5. Turn the Foot switch to the On position.

Note: Use the Foot switch when all the booms are to be turned on.

6. Ensure that the Boom 1, Boom 2, and Boom 3 switches are in the On position.
7. Set the Man/Rate switch to Rate 1.
8. Increase or decrease the vehicle speed by 1 mph (2 km/h).

Note: The system should automatically correct the target application rate. If the system does not correct the application rate, review the Initial System Setup; then refer to Troubleshooting.

9. After spraying a swath, switch the foot switch to the Off position to shut off the spray flow to all booms.

Note: This also shuts off the area calculations.

10. Verify the area covered and the volume of material sprayed.

Maintenance

Recommended Maintenance Schedule(s)

Maintenance Service Interval	Maintenance Procedure
Every 200 hours	<ul style="list-style-type: none"> • Clean the flowmeter (More often when using wettable powders).
Yearly	<ul style="list-style-type: none"> • Calibrate the flowmeter.

Cleaning the Flowmeter

Service Interval: Every 200 hours

1. Thoroughly rinse and drain the entire spraying system.
2. Remove the flowmeter from the sprayer and flush it with clean water.
3. Remove the retainer ring on the upstream side (Figure 11).

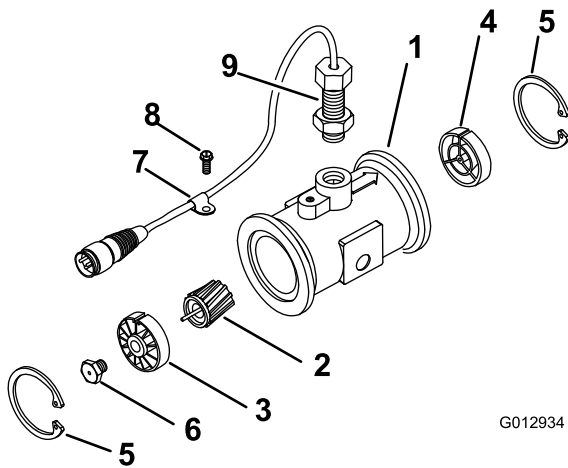

Figure 11

- | | |
|----------------------------------|--------------------------|
| 1. Modified flanged body | 6. Turbine stud assembly |
| 2. Rotor or magnet assembly | 7. Cable clamp |
| 3. Hub or bearing assembly | 8. Thread screw |
| 4. Hub assembly (with keyway up) | 9. Sensor assembly |
| 5. Retainer ring | |

4. Clean the turbine and the turbine hub to remove metal filings and any wettable powders.
5. Inspect the turbine blades for wear.

Note: Hold the turbine in your hand and spin it. It should spin freely with very little drag. If it does not spin freely, replace it.

6. Assemble the flowmeter.
7. Install the sensor until it gently touches the bottom of the housing.
8. Carefully tighten the sensor retaining nuts.

9. Use a low pressure (50 kPa or 5 psi) air jet to ensure that the turbine spins freely. If it does not spin freely, loosen the hex stud on the bottom of the turbine hub by 1/16 of a turn until the turbine spins freely.

Programming the Console Computer

With the controller power off, press and hold the CE button and move the power switch on the console computer to the On position.

Note: Turning the power switch to the Off position or disconnecting the console cables does not erase the data stored in the console computer memory.

Important: The calibration figures given are guidelines only; you should perform calculations for your particular machine and spraying application situation and conditions.

Note: Refer to Figure 9 and the Keypad Reference Table (page 8) for the description and function of the keys on the console computer.

To program the computer console, refer to Initially Programming the Console Computer in the Operation section.

Note: All the data is retained when you turn the power switch to the Off position.

Calculating the Boom Cal Data

The settings in the Pro Control XP are automatically set to the default settings. However, you can change the values if the nozzle spacing has changed.

Calculate the Boom Cal by multiplying the number of spray tips by the tip spacing.

Note: Boom 1 is the left boom (from the operating position), Boom 2 is the center boom, and Boom 3 is the right boom.

1. Press the [Boom 1 Cal] key.
2. Press the [Enter] key.
3. Enter **80** (US or TU) or **204** (SI).

4. Press the [Enter] key.
 5. Press the [Boom 2 Cal] key.
 6. Press the [Enter] key.
 7. Enter **60** (US or TU) or **152** (SI).
 8. Press the [Enter] key.
 9. Press the [Boom 3 Cal] key.
 10. Press the [Enter] key.
 11. Enter **80** (US or TU) or **204** (SI).
 12. Press the [Enter] key.
10. Enter the new Speed Cal number using the Entering the Speed Cal Number procedure.

Entering the Speed Cal Number

The Speed Cal number is critical to the performance of the spray system. Ensure that the tires are properly inflated and that the tank is half full before performing this procedure.

1. Press the [Speed Cal] key.
2. Press the [Enter] key.
3. Enter the correct Speed Cal number for your current selected unit of measurement (US, SI, TU).
 - When using US units, enter: **148**.
 - When using SI units, enter: **38**.
 - When using TU units, enter: **148**.
4. Press the [Enter] key.

Note: These number allow the machine to operate with reasonable accuracy. Fine tuning is necessary for maximum accuracy.

Fine-tuning the Speed Cal Number

The following procedure requires buttons 1 through 8 to have been populated with data and the CAL to stop flashing. Use the following procedure to further fine-tune the Speed Cal number:

1. Measure 152 m (500 feet) on a flat ground surface.
2. Set the distance readout to **0**.
3. Press the [Distance] key.
4. Press the [Enter] key.
5. Enter **0**.
6. Press the [Enter] key.
7. Drive the vehicle 152 m (500 feet).
8. Ensure that the distance readout on the console computer reads between 149 m and 155 m (490 feet and 510 feet).
9. If the readout is not between 149 m and 155 m (490 feet and 510 feet), calibrate the Speed Cal using the following equation:
 - New Speed Cal number = $148 \times 500 / \text{Distance readout}$ (for US or TU units)
 - New Speed Cal number = $38 \times 152 / \text{Distance readout}$ (for SI units)

Entering the Valve Cal Number

The Valve Cal number controls the response of the spray system to meet the changes of the vehicle speed.

Important: Running the control valve too fast (a number greater than zero) will cause the system to oscillate.

To enter the Valve Cal number:

1. Press the [Valve Cal] key.
2. Press the [Enter] key.
3. Enter the Valve Cal calibration number.

Note: The initial valve calibration number for Valve Cal is **023**. We recommend that you use this number for most spray applications; **046** may be helpful for small application rates (1.5 liters/min. or 0.4 gallons/min.).

4. Press the [Enter] key.

Entering Optional Calibration Values

You may also want to enter the following data, but it is not required for operating the spray system.

Volume Tank

This number represents the volume of material in the tank and must be entered each time you refill the tank. The function monitors the tank volume while you are spraying based on the total amount applied.

1. Press the [Vol/Tank] key.
2. Press the [Enter] key.
3. Enter the amount of material in the tank.
4. Press the [Enter] key.

Time

Enter the time of day based on a 24-hour day. For example, 1:30 p.m. is 13:30. You can also enter 0 to measure elapsed time.

To set the date, do the following:

1. Press the [Time] key. The display shows MONTH.
2. Press the [Enter] key to change the month.
3. Press the [Time] key. The display shows DAY.
4. Press the [Enter] key to change the day.
5. Press the [Time] key. The display shows YEAR.
6. Press the [Enter] key to change the year.
7. Press the [Time] key. The display shows POWER DOWN DAY.

Calibrating the Flowmeter

Service Interval: Yearly—Calibrate the flowmeter.

1. Press the [Meter Cal] key.
2. Press the [Enter] key.
3. Enter the Meter Cal number.

Note: The Meter Cal (or flowmeter) calibration number is stamped on the tag attached to the flowmeter or meter cable (Figure 10).

4. Press the [Enter] key.
5. Press the [Total Volume] key.
6. Press the [Enter] key.
7. Enter **0**.
8. Press the [Enter] key.
9. Fill the tank with a predetermined amount of water.

Note: For best results, measure the water using an independent method. For the best accuracy, determine the amount of water ahead of time so that the applicator tank is full.

10. Empty the tank by boom spraying under normal conditions.

Note: The vehicle does not need to be in motion to perform this step, but you must enter a test speed.

11. After emptying the water from the tank, check the Total Volume number. This number should equal the predetermined amount of water. If it does not, calculate the Meter Cal number using the formula that follows. Under normal conditions, the Meter Cal number should be within $\pm 3\%$ of the number stamped on the tag of the flowmeter.

See the example below:

Meter Cal (from tag) = 1660

Total Volume = 103

Amount of water = 100

Corrected Meter Cal = (Meter Cal x Total Volume) / Amount of Water

Corrected Meter Cal = (1660 x 103) / 100

Corrected Meter Cal = 1710.

Note: Repeat this procedure several times to confirm that the corrected Meter Cal number is accurate.

Testing the Flowmeter Cable

1. Disconnect the console control cable from the flowmeter cable.
2. Hold the cable so that the keyway is in the 12 o'clock position (Fig. Figure 12).

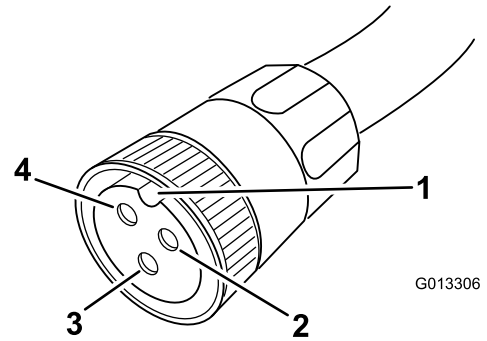

Figure 12

1. Keyway
2. Ground (2 o'clock position)
3. Signal (6 o'clock position)
4. Power (10 o'clock position)

3. Enter a Meter Cal number; refer to Entering the Meter Cal Number in the Operation section.
4. Press the [Total Volume] key.
5. Turn the Pump, Foot, and Boom switches to the On position.
6. Use a small jumper wire or a paper clip to create a short between the 2 o'clock and 6 o'clock sockets.

Note: Each time you make contact, the Total Volume should increase by 1 or more counts.

7. If the Total Volume number does not increase, replace the defective cable.
8. Perform the voltage checks: 2 o'clock to 6 o'clock (+5 VDC); and 2 o'clock to 10 o'clock (+5 VDC).
9. If all the cables are good, replace the flow sensor.

Note: After testing the flowmeter cables, enter the correct Meter Cal number before spraying.

Troubleshooting

Note: If the console computer malfunctions or needs repair, you can resume spraying in manual mode by unplugging the cables from the rear of the console computer. You can then control the system using the center console controls.

Problem	Possible Cause	Corrective Action
The display lights do not illuminate when the power turned On.	<ol style="list-style-type: none"> 1. The fuse on the back of the console computer is blown. 2. The battery connections are loose. 3. The power switch is not operating properly. 4. There is a problem with the processor board assembly. 	<ol style="list-style-type: none"> 1. Replace the fuse. 2. Secure the battery connections. 3. Repair or replace the power switch. 4. Have an Authorized Distributor replace the processor board assembly.
All of the keyboard lights are illuminated at the same time	<ol style="list-style-type: none"> 1. There is a problem with the face plate sub assembly. 	<ol style="list-style-type: none"> 1. Have an Authorized Distributor replace the face plate sub assembly.
You cannot enter a digit using the keyboard.	<ol style="list-style-type: none"> 1. There is a problem with the face plate sub assembly. 	<ol style="list-style-type: none"> 1. Have an Authorized Distributor replace the face plate sub assembly.
An indicator on a key does not illuminate.	<ol style="list-style-type: none"> 1. There is a problem with the face plate sub assembly. 	<ol style="list-style-type: none"> 1. Have an Authorized Distributor replace the face plate sub assembly.
The console computer displays a flashing Cal indicator whenever you start the engine.	<ol style="list-style-type: none"> 1. The battery connections are loose. 2. The battery is not providing sufficient voltage. 3. One or more of the Console keys 1 through 8 do not have a value. 	<ol style="list-style-type: none"> 1. Secure the battery connections. 2. Check the battery voltage. 3. Ensure that Console keys 1 through 8 are assigned a value.
The console computer displays a flashing Cal indicator whenever you turn the master switch to the On or Off position.	<ol style="list-style-type: none"> 1. The battery connections are loose. 2. The battery is not providing sufficient voltage. 3. One or more of the Console keys 1 through 8 do not have a value. 	<ol style="list-style-type: none"> 1. Secure the battery connections. 2. Check the battery voltage. 3. Ensure that Console keys 1 through 8 are assigned a value.
The console computer displays a flashing Cal indicator whenever you change the speed.	<ol style="list-style-type: none"> 1. The battery connections are loose. 2. The battery is not providing sufficient voltage. 3. One or more of the Console keys 1 through 8 do not have a value. 	<ol style="list-style-type: none"> 1. Secure the battery connections. 2. Check the battery voltage. 3. Ensure that Console keys 1 through 8 are assigned a value.
One of the display digit has one or more missing segments.	<ol style="list-style-type: none"> 1. There is a problem with the LCD display board assembly. 	<ol style="list-style-type: none"> 1. Have an Authorized Distributor replace the LCD display board assembly.
The speed display indicates 0.	<ol style="list-style-type: none"> 1. The pins on the speed sensor cable connector and the plug on the back of the console computer are loose. 2. The pins and the sockets on the speed sensor cable are dirty. 3. There is a problem with the speed sensor switch assembly. 	<ol style="list-style-type: none"> 1. Have an Authorized Distributor repair or replace the connector or the plug on the back of the console computer. 2. Clean the pins and sockets on the speed sensor cable connectors. 3. Have an Authorized Distributor replace the speed sensor switch assembly.
The speed indication that is displayed is inaccurate or unstable.	<ol style="list-style-type: none"> 1. The wheel drive setting is not set to SP3. 2. The Speed Cal number is incorrect. 	<ol style="list-style-type: none"> 1. Set the wheel drive setting to SP3. 2. Enter the correct Speed Cal number.
The rate display indicates 0000.	<ol style="list-style-type: none"> 1. The Speed Cal is zero. 2. The wheel drive setting is not set to SP3. 3. The Total Volume is not registering the flow. 	<ol style="list-style-type: none"> 1. Enter the correct Speed Cal number. 2. Set the wheel drive setting to SP3. 3. Ensure that the flowmeter is pointing in the direction of flow and is operating properly.

Problem	Possible Cause	Corrective Action
The rate indication that is displayed is inaccurate or unstable.	<ol style="list-style-type: none"> 1. You incorrectly entered a number in the console computer. 2. The wheel drive setting is not set to SP3. 3. The Speed Cal number is incorrect. 4. The Rate 1 or Rate 2 display is not constant when the speed is constant. 5. The pressure cannot be adjusted in manual mode with the agitation on and the booms off in the high end of the pressure range. 6. The Valve Cal number is not properly set. 7. There is a problem with the processor board assembly. 	<ol style="list-style-type: none"> 1. Verify that all the numbers entered in the console computer are correct. 2. Set the wheel drive setting to SP3. 3. Enter the correct Speed Cal number. 4. Ensure that the flowmeter is pointing in the direction of flow and the nozzles are appropriate for the rate setting. 5. Verify that there is voltage at the valve connector by placing the Master switch to Man with the booms in the Off position and the power switch to the On position. Manually operate the Incr/Decr switch to verify the voltage. 6. Enter proper the Valve Cal number. 7. Have an Authorized Distributor replace the processor board assembly.
You cannot vary the rate in either the manual mode or automatic mode.	<ol style="list-style-type: none"> 1. There are breaks in the cable leading to the hydraulic control valve. 2. The connections in the cable line are dirty. 3. There is no voltage at the valve connector. 4. The Rate Inc/Dec switch is faulty. 	<ol style="list-style-type: none"> 1. Replace the cable. 2. Clean or replace the cable line. 3. Verify that there is voltage at the valve connector by placing the Master switch to the Man position with the booms in the Off position and the power switch to the On position. Manually operate the Incr/Decr switch to verify the voltage. 4. Replace the Rate Inc/Dec switch.
The total volume does not register.	<ol style="list-style-type: none"> 1. There are breaks or shorts in the flowmeter cable. 2. The inside of the flowmeter is dirty or not properly adjusted. 3. The flowmeter transducer is not operating properly. 	<ol style="list-style-type: none"> 1. Test the flowmeter cable and repair or replace it if necessary. Refer to Testing the Flowmeter Cable on page 15. 2. Clean and make any necessary adjustments inside the flowmeter. 3. Replace the flowmeter transducer.
The total volume inaccurately registers flow.	<ol style="list-style-type: none"> 1. The flowmeter is not pointing in the direction of the flow. 2. The flowmeter is faulty. 	<ol style="list-style-type: none"> 1. Install the flowmeter in the direction of the flow. 2. Test the flowmeter cable and repair or replace it if necessary. Refer to Testing the Flowmeter Cable.

Notes:

Notes:



Count on it.