



**Count on it.**

**Operator's Manual**

# 53cm Heavy-Duty Recycler<sup>®</sup>/Rear Bagger Lawn Mower

Model No. 22291—Serial No. 31400001 and Up

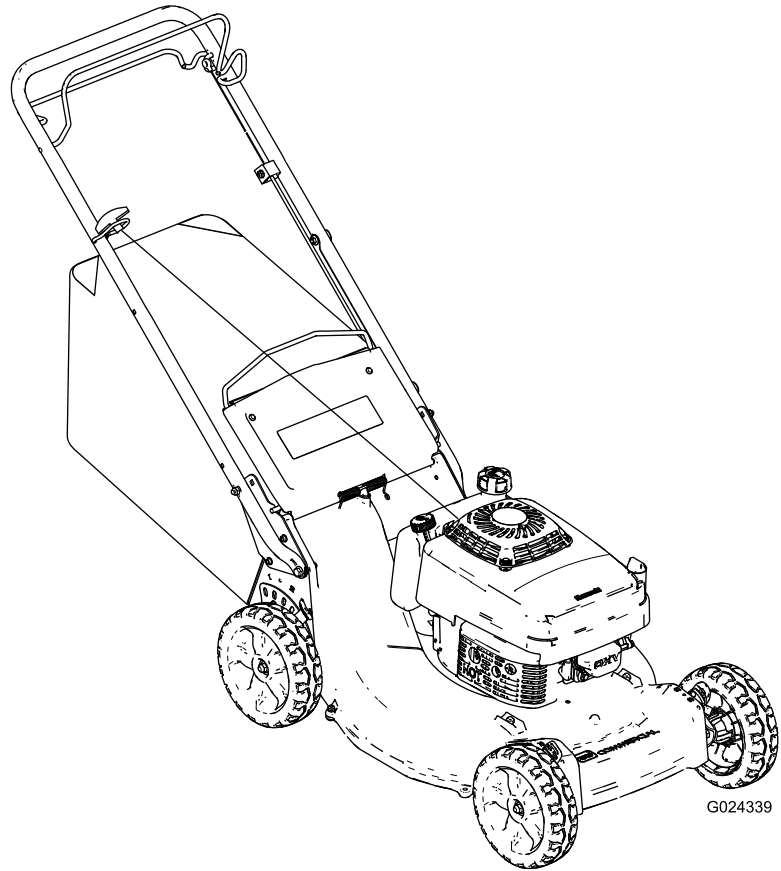

G024339



This product complies with all relevant European directives. For details, see the separate product-specific Declaration of Conformity (DOC) sheet.



Figure 2

1. Safety alert symbol

# Introduction

**This rotary-blade, walk-behind lawn mower is intended to be used by residential homeowners or professional, hired operators. It is designed primarily for cutting grass on well-maintained lawns on residential or commercial properties. It is not designed for cutting brush or for agricultural uses.**

Read this information carefully to learn how to operate and maintain your machine properly and to avoid injury and equipment damage. You are responsible for operating the machine properly and safely.

You may contact Toro directly at [www.Toro.com](http://www.Toro.com) for product and accessory information, help finding a dealer, or to register your product.

Whenever you need service, genuine Toro parts, or additional information, contact an Authorized Service Dealer or Toro Customer Service and have the model and serial numbers of your machine ready. Figure 1 identifies the location of the model and serial numbers on the product. Write the numbers in the space provided.

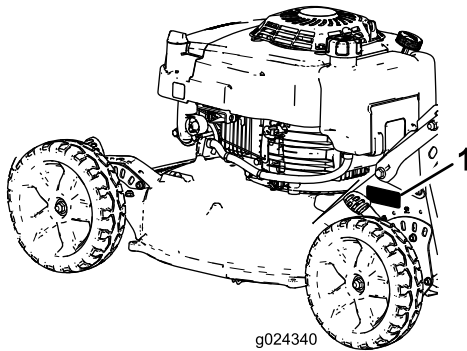

Figure 1

1. Model and serial number plate

<b>Model No.</b> _____
<b>Serial No.</b> _____

This manual identifies potential hazards and has safety messages identified by the safety alert symbol (Figure 2), which signals a hazard that may cause serious injury or death if you do not follow the recommended precautions.

This manual uses 2 words to highlight information. **Important** calls attention to special mechanical information and **Note** emphasizes general information worthy of special attention.

## Net Torque

The gross or net torque of this engine was laboratory rated by the engine manufacturer in accordance with the Society of Automotive Engineers (SAE) J1940. As configured to meet safety, emission, and operating requirements, the actual engine torque on this class of mower will be significantly lower.

# Contents

Introduction .....	2
Safety .....	3
General Lawn Mower Safety .....	3
Sound Pressure .....	5
Sound Power .....	5
Hand/Arm Vibration .....	5
Safety and Instructional Decals .....	6
Setup .....	8
1 Installing the Handle .....	8
2 Installing the Recoil-start Rope .....	10
3 Filling the Crankcase with Oil .....	10
4 Adjusting the Self-propel Drive .....	11
Product Overview .....	11
Operation .....	12
Checking the Engine-oil Level .....	12
Filling the Fuel Tank with Gasoline .....	12
Adjusting the Cutting Height .....	13
Starting the Engine .....	13
Stopping the Engine .....	13
Operating the Self-propel Drive .....	14
Recycling the Clippings .....	14
Bagging the Clippings .....	14
Operating Tips .....	15
Maintenance .....	17
Recommended Maintenance Schedule(s) .....	17
Engine Maintenance .....	18
Servicing the Air Cleaner .....	18
Changing the Engine Oil .....	18
Servicing the Spark Plug .....	19
Drive System Maintenance .....	19
Adjusting the Self-propel Drive .....	19
Blade Maintenance .....	20
Maintaining the Blade .....	20
Cleaning .....	21
Cleaning under the Mower Housing .....	21
Storage .....	22
Preparing the Fuel System .....	22
Preparing the Engine .....	22
General Information .....	22
Removing the Machine from Storage .....	23
Troubleshooting .....	24

# Safety

**Improperly using or maintaining this machine can result in injury. To reduce the potential for injury, comply with these safety instructions.**

Toro designed and tested this machine for reasonably safe service; however, failure to comply with the following instructions may result in personal injury.

**To ensure maximum safety, best performance, and to gain knowledge of the product, it is essential that you and any other operator of the mower read and understand the contents of this manual before the engine is ever started. Pay particular attention to the safety alert symbol (Figure 2), which means Caution, Warning, or Danger. Read and understand the instruction because it has to do with safety. Failure to comply with the instruction may result in personal injury.**

## General Lawn Mower Safety

The following instructions have been adapted from EN 836.

This cutting machine is capable of amputating hands and feet and of throwing objects. Failure to observe the following safety instructions could result in serious injury or death.

## Training

- Read the instructions carefully. Be familiar with the controls and the proper use of the equipment.
- Never allow children or people unfamiliar with these instructions to use the mower. Local regulations can restrict the age of the operator.
- Keep in mind that the operator or user is responsible for accidents or hazards occurring to other people or their property.
- Understand explanations for all pictograms used on the mower or in the instructions.

## Gasoline

**WARNING!** Gasoline is highly flammable. Take the following precautions.

- Store fuel in containers specifically designed for this purpose.
- Refuel outdoors only and do not smoke while refueling.
- Add fuel before starting the engine. Never remove the cap of the fuel tank or add gasoline while the engine is running or when the engine is hot.
- If gasoline is spilled, do not attempt to start the engine but move the mower away from the area of spillage and avoid creating any source of ignition until gasoline vapors have dissipated.
- Replace all fuel tank and container caps securely.

## Preparation

- While mowing, always wear substantial footwear and long trousers. Do not operate the equipment when barefoot or wearing open sandals.
- Thoroughly inspect the area where the equipment is to be used and remove all stones, sticks, wires, bones, and other foreign objects.
- Before using, always visually inspect to see that guards, and safety devices, such as deflectors and/or grass catchers, are in place and working correctly.
- Before using, always visually inspect to see that the blades, blade bolts, and cutter assembly are not worn or damaged. Replace worn or damaged blades and bolts in sets to preserve balance.

## Starting

- Disengage all blade and drive clutches, and shift into neutral before starting the engine.
- Do not tilt the mower when starting the engine unless the mower has to be tilted for starting. In this case, do not tilt it more than absolutely necessary, and lift only the part which is away from the operator.
- Start the engine carefully according to instructions and with feet well away from the blade(s) and not in front of the discharge chute.

## Operation

- Never mow while people, especially children, or pets are nearby.
- Mow only in daylight or in good artificial light.
- Stay alert for holes in the terrain and other hidden hazards.
- Do not put hands or feet near or under rotating parts. Keep clear of the discharge opening at all times.
- Never pick up or carry a lawn mower while the engine is running.
- Use extreme caution when reversing or pulling a pedestrian-controlled lawn mower toward you.
- Walk, never run.
- Slopes:
  - Do not mow excessively steep slopes.
  - Exercise extreme caution when on slopes.
  - Mow across the face of slopes, never up and down, and exercise extreme caution when changing direction on slopes.
  - Always be sure of your footing on slopes.
- Reduce speed on slopes and in sharp turns to prevent overturning or loss of control.
- Stop the blade if the machine has to be tilted for transportation when crossing surfaces other than grass and when transporting the machine to and from the area to be mowed.

- Do not operate the engine in a confined space where dangerous carbon monoxide fumes can collect.
- Stop the engine
  - whenever you leave the machine.
  - before refueling.
  - before removing the grass catcher.
  - before making height adjustment unless adjustment can be made from the operator's position.
- Stop the engine and disconnect the spark-plug wire
  - before clearing blockages or unclogging chute.
  - before checking, cleaning or working on the machine.
  - after striking a foreign object, inspect the lawn mower for damage and make repairs before starting and operating the lawn mower.
  - if lawn mower starts to vibrate abnormally (check immediately).
- Lightning can cause severe injury or death. If you see lightning or hear thunder in the area, do not operate the machine; seek shelter.
- Watch out for traffic when crossing or near roadways.

## Maintenance and Storage

- Keep all nuts, bolts, and screws tight to be sure that the equipment is in safe working condition.
- Do not use pressure-cleaning equipment on machine.
- Never store the equipment with gasoline in the tank and inside a building where fumes can reach an open flame or spark.
- Allow the engine to cool before storing in any enclosure.
- To reduce the fire hazard, keep the engine, silencer, battery compartment and gasoline storage area free of grass, leaves, or excessive grease.
- Check the grass catcher components and the discharge guard frequently, and replace them with manufacturer's recommended parts, when necessary.
- Replace worn or damaged parts for safety.
- Replace faulty silencers.
- If the fuel tank has to be drained, do this outdoors.
- Do not change the engine governor settings or overspeed the engine. Operating an engine at excessive speed can increase the hazard of personal injury.
- Be careful during adjustment of the machine to prevent entrapment of the fingers between moving blades and fixed parts of the machine.
- **To best protect your investment and maintain optimal performance of your Toro equipment, count on Toro genuine parts. When it comes to reliability, Toro delivers replacement parts designed to the exact engineering specifications of our equipment. For peace of mind, insist on Toro genuine parts.**

## Sound Pressure

This unit has a sound pressure level at the operator's ear of 88 dBA, which includes an Uncertainty Value (K) of 1 dBA.

The sound pressure level was determined according to the procedures outlined in EN 836.

## Sound Power

This unit has a guaranteed sound power level of 98 dBA, which includes an Uncertainty Value (K) of 1 dBA.

The sound power level was determined according to the procedures outlined in ISO 11094.

## Hand/Arm Vibration

Measured vibration level for left hand = 2.3 m/s<sup>2</sup>

Measured vibration level for right hand = 2.7 m/s<sup>2</sup>

Uncertainty Value (K) = 1.4 m/s<sup>2</sup>

Measured values were determined according to the procedures outlined in EN 836.

# Safety and Instructional Decals

**Important:** Safety and instruction decals are located near areas of potential danger. Replace damaged decals.

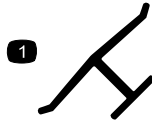

**Manufacturer's Mark**

1. Indicates the blade is identified as a part from the original machine manufacturer.

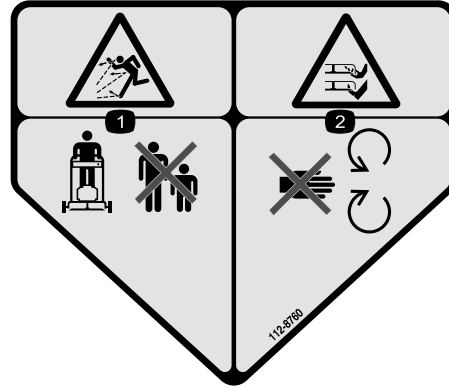

**112-8760**

1. Thrown object hazard—keep bystanders a safe distance from the machine.
2. Cutting/dismemberment of hand or foot—stay away from moving parts.



**116-7583**

1. Warning—Read the Operator's Manual. Do not operate this machine unless you are trained.
2. Thrown object hazard—keep bystanders a safe distance from the machine.
3. Thrown object hazard—Do not operate the mower without the rear discharge plug or bag in place.
4. Cutting/dismemberment hazard of hand or foot, mower blade—stay away from moving parts; keep all guards in place.
5. Warning—wear hearing protection.
6. Cutting/dismemberment hazard of hand or foot, mower blade—Do not operate up and down slopes; operate side to side on slopes; stop the engine before leaving the operating position—pick up objects that could be thrown by the blades; and look behind you when backing up.

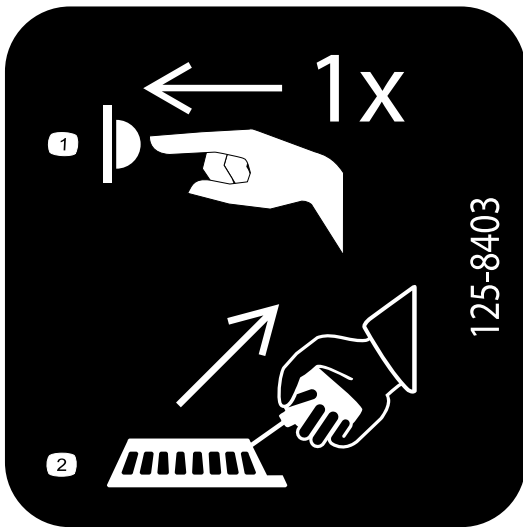

125-8403

1. Push the primer once.
2. Pull the recoil start handle.

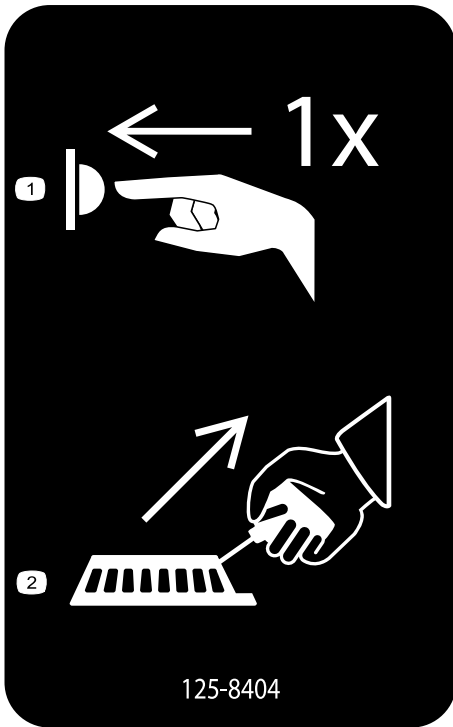

125-8404

1. Push the primer once.
2. Pull the recoil start handle.

		130-6722
<p><b>AJUSTE DE LA TRANSMISIÓN AUTOPROPULSADA:</b> No apretar demasiado para evitar un desgaste prematuro de la transmisión. Consultar las instrucciones de ajuste y seguridad del Manual del operador.</p>	<p><b>ADJUSTING THE SELF PROPEL DRIVE:</b> Do not over-tighten or premature transmission wear may occur. Refer to operator's manual for adjustment and safety instructions.</p>	
<p><b>EINSTELLEN DES SELBSTANTRIEBS:</b> Bitte beachten sie die Einstellungshinweise in der Bedienungsanleitung, durch falsche Justierung kann das Getriebe vorzeitig verschleßen.</p>	<p><b>RÉGLAGE DE L'AUTOTRACTION :</b> Ne pas serrer excessivement, au risque d'entraîner une usure prématurée de la transmission. Se reporter au manuel de l'utilisateur pour connaître les instructions de réglage et de sécurité.</p>	

130-6722

1. Attention—read the *Operator's Manual*.

# Setup

## Loose Parts

Use the chart below to verify that all parts have been shipped.

Procedure	Description	Qty.	Use
<b>1</b>	Handle	1	Install the handle.
	Hex-head-flange bolt (5/16 x 1-1/2 inches)	2	
	Carriage bolt (5/16 x 1-1/2 inches)	2	
	Flange nut (5/16 inch)	4	
<b>2</b>	No parts required	–	Install the starter rope.
<b>3</b>	No parts required	–	Fill the crankcase with oil.
<b>4</b>	No parts required	–	Adjust the self-propel drive.

**Note:** Determine the left and right sides of the machine from the normal operating position.

# 1

## Installing the Handle

### Parts needed for this procedure:

1	Handle
2	Hex-head-flange bolt (5/16 x 1-1/2 inches)
2	Carriage bolt (5/16 x 1-1/2 inches)
4	Flange nut (5/16 inch)

### Procedure

1. Remove the cable guard from the handle (Figure 3) by removing the 2 carriage bolts and 2 locknuts that hold the cable guard to the handle.

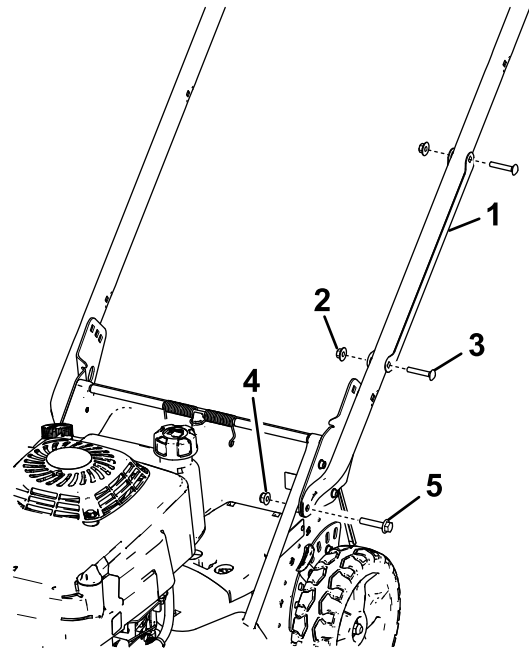

g024341

**Figure 3**

- |   |   |
|---|---|
| 1. Cable guard                          | 4. Flange nut—5/16 inch (2)                     |
| 2. Locknut (2)                          | 5. Hex-head-flange bolt—5/16 x 1-1/2 inches (2) |
| 3. Carriage bolt—1/4 x 1-1/2 inches (2) |   |

**Note:** Save the guard, the carriage bolts, and the locknuts so that you can install it onto the handle later in this procedure.

2. Install the handle ends onto the mower housing with 2 hex-head-flange bolts (5/16 x 1-1/2 inches) and 2 flange nuts (5/16 inch) as shown in Figure 3.



3. Set the machine to the desired cutting height; refer to Adjusting the Cutting Height (page 13).
4. Stand behind the machine in the operating position to determine the handle height that is most comfortable for you (Figure 4).

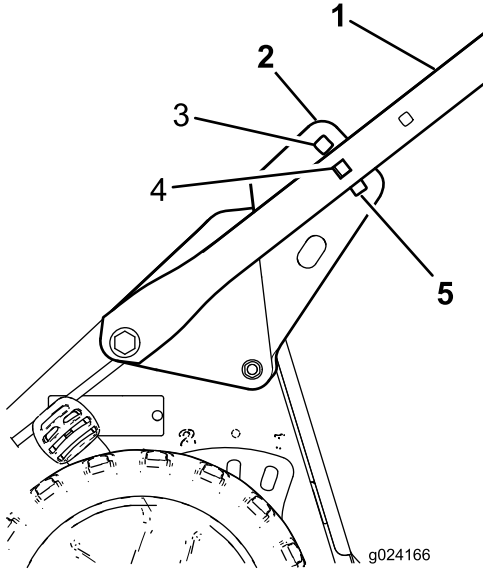
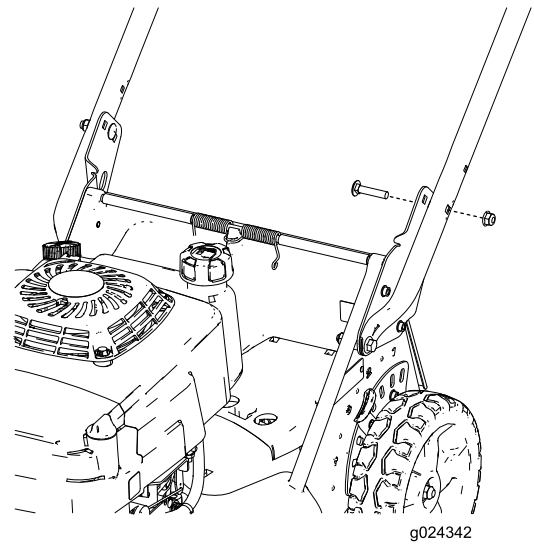

**Figure 4**

- |                          |                         |
|--------------------------|-------------------------|
| 1. Handle                | 4. Medium handle height |
| 2. Handle bracket (2)    | 5. Lowest handle height |
| 3. Highest handle height |                         |

5. Secure the handle onto the handle brackets at your desired handle height with 2 carriage bolts (5/16 x 1-1/2 inches) and 2 flange nuts (5/16 inch) as shown in Figure 5.

**Important:** Ensure that the bolt heads are on the inside of the handle and the nuts are on the outside of the handle.



**Figure 5**

- |  |                             |
|--|-----------------------------|
| 1. Carriage bolt—5/16 x 1-1/2 inches (2) | 3. Flange nut—5/16 inch (2) |
| 2. Handle bracket (2)                    |                             |

6. Position the cable guard onto the handle with the cable(s) inside the guard, and secure the guard to the handle with the 2 carriage bolts and the 2 locknuts that you previously removed (Figure 3).

**Important:** Ensure that you do not pinch the cable(s) to the handle with when you install the cable guards onto the handle.

# 2

## Installing the Recoil-start Rope

### No Parts Required

### Procedure

Pull the recoil-start rope through the rope guide on the handle (Figure 6).

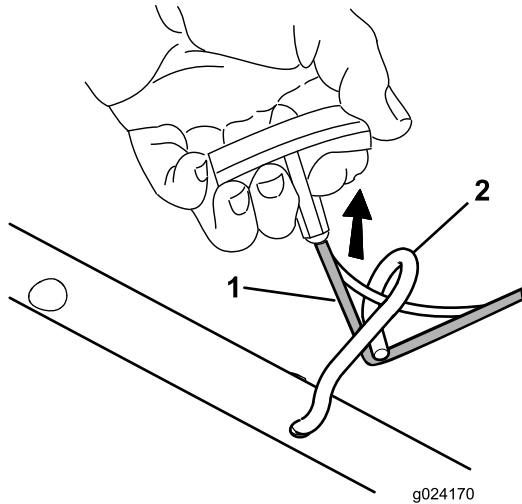

Figure 6

1. Recoil-start rope
2. Rope guide

**Note:** To make the rope easier to install, squeeze the blade-control bar on the handle.

# 3

## Filling the Crankcase with Oil

### No Parts Required

### Procedure

The engine crankcase is shipped without oil. Before starting the engine, fill the crankcase with oil. The engine crankcase (with oil filter) can hold 0.65 L (22 oz) of oil. Use only high-quality SAE 10W-30 weight detergent oil that has the American Petroleum Institute (API) service classification SH, SJ, or equivalent.

Before each use, ensure that the oil level is between the Add and the Full marks on the dipstick (Figure 7).

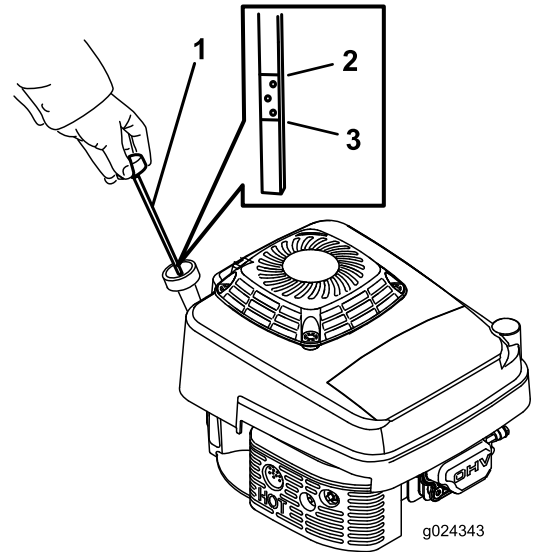

Figure 7

1. Dipstick
2. Full mark
3. Add mark

**Note:** When the crankcase is empty, pour about 3/4 of the crankcase capacity of oil in the crankcase, then follow the procedure in this section.

1. Move the machine onto a level surface.
2. Clean around the dipstick (Figure 7).
3. Remove the dipstick by rotating the cap counterclockwise and pulling it out.
4. Wipe the dipstick clean with a clean cloth.
5. Insert the dipstick into the filler neck, then remove the dipstick.
6. Read the oil level on the dipstick.
  - If the oil level is below the Add mark on the dipstick, slowly pour a small amount of oil into the oil-fill tube, wait 3 minutes, and repeat steps 4

through 6 until the oil level is at the Full mark on the dipstick.

- If the oil level is above the Full mark on the dipstick, drain the excess oil until the oil level on the dipstick is at the Full mark. Refer to Changing the Engine Oil (page 18).

**Important:** If the oil level in the crankcase is too low or too high and you run the engine, you may damage the engine.

7. Insert the dipstick into the filler neck and rotate the cap clockwise until it is tight.

# 4

## Adjusting the Self-propel Drive

### No Parts Required

### Procedure

**Important:** You must adjust the self-propel-drive cable before you operate the machine for the first time. Refer to Adjusting the Self-propel Drive (page 19).

# Product Overview

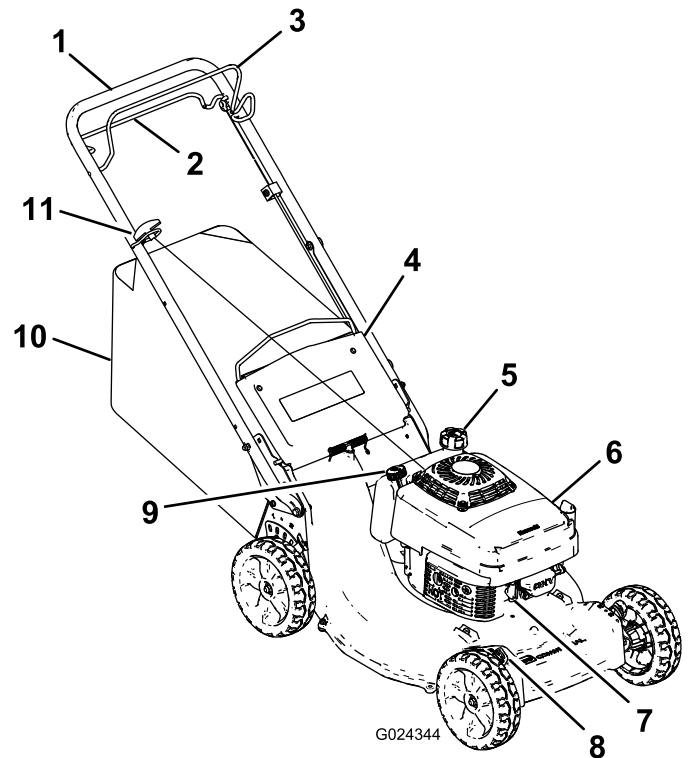

Figure 8

- |                          |                             |
|--------------------------|-----------------------------|
| 1. Handle                | 7. Spark plug               |
| 2. Self-propel-drive bar | 8. Cutting-height lever (4) |
| 3. Blade-control bar     | 9. Oil fill/dipstick        |
| 4. Rear door             | 10. Grass bag               |
| 5. Fuel-tank cap         | 11. Recoil-start handle     |
| 6. Air cleaner           |                             |

# Operation

**Note:** Determine the left and right sides of the machine from the normal operating position.

Each time before you mow, ensure that the self-propel drive and the blade-control bar operate properly. When you release the blade-control bar, the blade and the self-propel drive should stop. If they do not, contact an Authorized Service Dealer.

## ⚠ CAUTION

This machine produces sound levels in excess of 85dBA at the operator's ear and can cause hearing loss through extended periods of exposure.

Wear hearing protection when operating this machine.



Figure 9

1. Warning—wear hearing protection.

## Checking the Engine-oil Level

**Service Interval:** Before each use or daily—Check the engine-oil level.

Before you use the machine, ensure that the oil level is between the Add and the Full marks as shown on the dipstick (Figure 10).

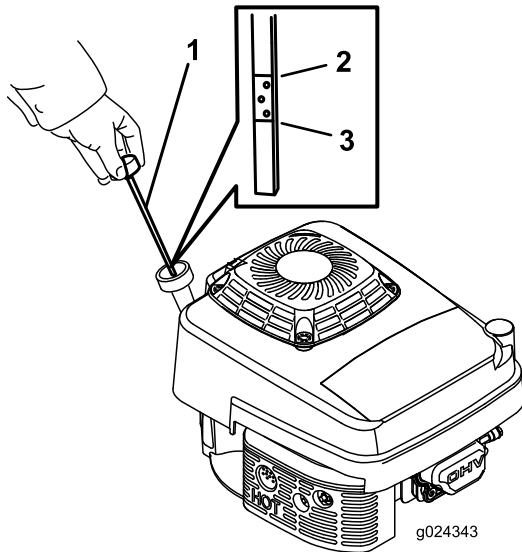

Figure 10

1. Dipstick
2. Full mark
3. Add mark

If the oil level is below the Add mark, add oil. Refer to 3 Filling the Crankcase with Oil (page 10).

## Filling the Fuel Tank with Gasoline

### ⚠ DANGER

Gasoline is extremely flammable and explosive. A fire or explosion from gasoline can burn you and others.

- To prevent a static charge from igniting the gasoline, place the container and/or machine directly on the ground before filling, not in a vehicle or on an object.
- Fill the tank outdoors when the engine is cold. Wipe up spills.
- Do not handle gasoline when smoking or around an open flame or sparks.
- Store gasoline in an approved fuel container, out of the reach of children.
- For best results, use only clean, fresh (less than 30 days old), unleaded gasoline with an octane rating of 87 or higher ((R+M)/2 rating method).
- Oxygenated fuel with up to 10% ethanol or 15% MTBE by volume is acceptable.
- **Ethanol:** Gasoline with up to 10% ethanol (gasohol) or 15% MTBE (methyl tertiary butyl ether) by volume is acceptable. Ethanol and MTBE are not the same. Gasoline with 15% ethanol (E15) by volume is not approved for use. **Never use gasoline that contains more than 10% ethanol by volume**, such as E15 (contains 15% ethanol), E20 (contains 20% ethanol), or E85 (contains up to 85% ethanol). Using unapproved gasoline may cause performance problems and/or engine damage which may not be covered under warranty.
- Do not use gasoline containing methanol.
- Do not store fuel either in the fuel tank or in fuel containers over the winter unless a fuel stabilizer is used.
- Do not add oil to gasoline.

**Important:** To reduce starting problems, add fuel stabilizer to the fuel all season, mixing it with gasoline less than 30 days old.

**Note:** The capacity of the fuel tank is 1.8 L (0.47 US gallon).

## Adjusting the Cutting Height

You can change the cutting height at each wheel by adjusting a cutting-height lever. Cutting heights are 25 mm (1 inch), 38 mm (1-1/2 inches), 51 mm (2 inches), 64 mm (2-1/2 inches), 76 mm (3 inches), 89 mm (3-1/2 inches), 102 mm (4 inches), 114 mm (4-1/2 inches).

### **⚠ DANGER**

Adjusting the cutting-height levers could bring your hands into contact with a moving blade and result in serious injury.

- Stop the engine and wait for all movement to stop before adjusting the cutting height.
- Do not put your fingers under the housing when adjusting the cutting height.

1. Pull the cutting-height lever toward the wheel (Figure 11) and move the lever to the desired setting.

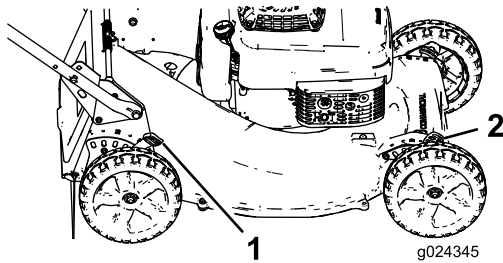

Figure 11

1. Rear cutting-height lever (2)
2. Front cutting-height lever (2)

2. Release the cutting-height lever and seat it securely in the notch.
3. Adjust all the wheels to the same cutting-height setting.

## Starting the Engine

1. Connect the spark-plug wire to the spark plug.
2. Firmly push in the primer (Figure 12), holding the primer bulb in for 1 second.

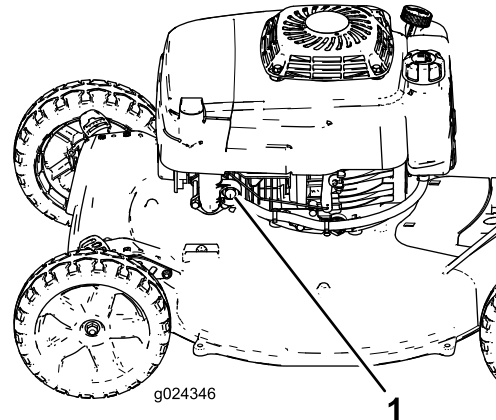

Figure 12

1. Primer

3. Hold the blade-control bar against the upper handle (Figure 13).

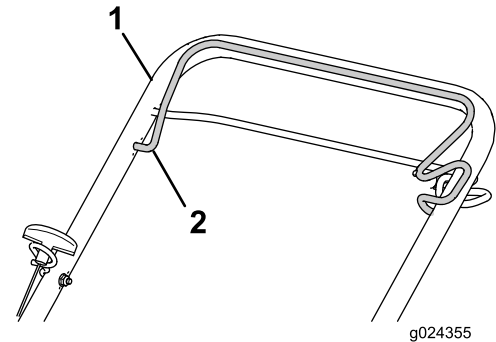

Figure 13

1. Upper handle
2. Blade-control bar

4. Pull the starter handle lightly until you feel resistance, pull it sharply, then allow it to return slowly to the rope guide on the handle.

**Note:** If the engine does not start, repeat steps 2 through 4.

## Stopping the Engine

Release the blade-control bar. Both the engine and the blade should stop within 3 seconds. If they do not, contact an Authorized Service Dealer.

# Operating the Self-propel Drive

- **To engage the self-propel-drive:** Squeeze the self-propel-drive bar against the handle and hold it (Figure 14).

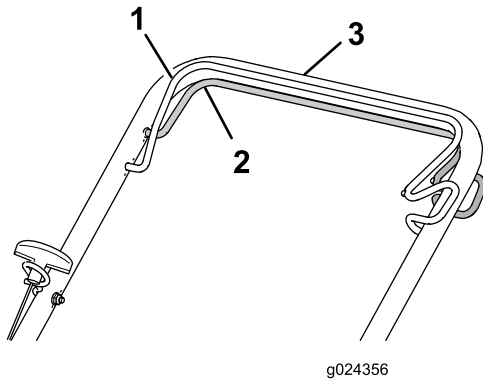

Figure 14

1. Blade-control bar (shown engaged)
2. Self-propel-drive bar
3. Upper handle engaged

**Note:** The maximum self-propel-drive speed is fixed. To reduce the speed, increase the space between the self-propel-drive bar and the handle.

- **To disengage the self-propel drive:** Release the self-propel-drive bar.

**Note:** The machine comes with freewheeling clutches that make it easier to pull the machine rearward. To disengage the clutches, you may need to push the machine forward about 2.5 cm (1 inch) or more after you release the self-propel-drive bar.

## Recycling the Clippings

This machine comes from the factory ready to recycle grass and leaf clippings back into the lawn. To prepare the machine to recycle:

- If the grass bag is on the machine, remove it; refer to Removing the Grass Bag (page 15).
- If the rear-discharge plug is not installed, grip it by the handle, raise the rear door, and insert it into the rear-discharge chute until the latch locks into place (Figure 15).

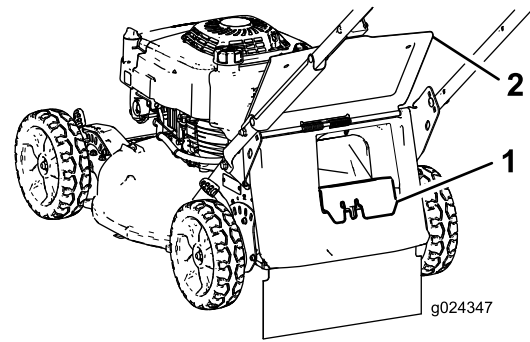

Figure 15

1. Rear-discharge plug
2. Rear door

### ⚠ WARNING

Operating the machine to recycle lawn clippings without the plug in place allows objects to be thrown in your direction or in the direction of bystanders. Also, contact with the blades could occur. Thrown objects or blade contact can cause serious injury or death.

Ensure that the rear-discharge plug is in place before you recycle the clippings. Never engage the blades without either the rear-discharge plug or the grass bag installed on the machine.

## Bagging the Clippings

Use the grass bag when you want to collect grass and leaf clippings from the lawn.

### ⚠ WARNING

A worn grass bag could allow small stones and other similar debris to be thrown in your direction or in the direction of bystanders, resulting in serious personal injury or death.

Check the grass bag frequently. If it is damaged, install a new Toro replacement bag.

### ⚠ WARNING

The blades are sharp; contacting the blades can result in serious personal injury.

Stop the engine and wait for all moving parts to stop before leaving the operating position.

## Installing the Grass Bag

1. Stop the engine and wait for all moving parts to stop.
2. Raise and hold up the rear door (Figure 16).

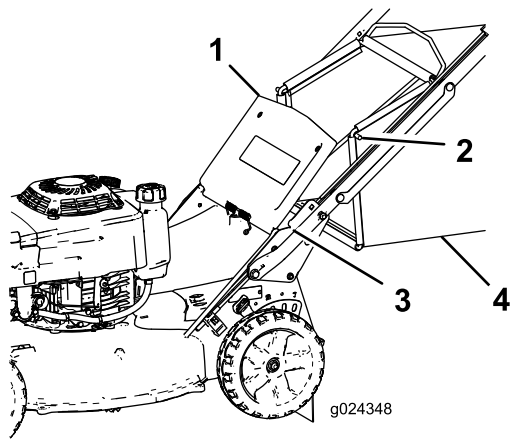

**Figure 16**

- |                    |              |
|--------------------|--------------|
| 1. Rear door       | 3. Notch (2) |
| 2. Bag-rod end (2) | 4. Grass bag |

3. Remove the rear-discharge plug by pushing in the latch with your thumb and pulling the plug out from the machine (Figure 15).
4. Install the bag-rod ends into the notches at the base of the handle, and rock the bag back and forth to ensure that the bag-rod ends are seated at the bottom of both notches (Figure 16).
5. Lower the rear door until it rests on the grass bag.

## Removing the Grass Bag

### **⚠ DANGER**

The machine can throw grass clippings and other objects through an opening in the mower housing. Objects thrown with enough force could cause serious personal injury or death to you or to bystanders.

- Never remove the grass bag and then start the engine without the discharge plug installed on the machine.
  - Never open the rear door on the machine when the engine is running.
1. Stop the engine and wait for all moving parts to stop.
  2. Raise the rear door.
  3. Remove the bag rod on the grass bag from the notches at the base of the handle (Figure 16).
  4. Install the discharge plug; refer to Recycling the Clippings (page 14).
  5. Lower the rear door.

## Operating Tips

### General Tips

- Review the safety instructions and read this manual carefully before operating the machine.
- Clear the area of sticks, stones, wire, branches, and other debris that the blade could hit and throw.
- Keep everyone, especially children and pets, away from the area of operation.
- Avoid striking trees, walls, curbs, or other solid objects. Never deliberately mow over any object.
- If the machine strikes an object or starts to vibrate, immediately stop the engine, disconnect the wire from the spark plug, and examine the machine for damage.
- Maintain a **sharp blade** throughout the cutting season. Periodically file down nicks on the blade.
- Replace the blade when necessary with an original Toro replacement blade.
- Mow only dry grass or leaves. Wet grass and leaves tend to clump on the yard and can cause the machine to plug or the engine to stall.

### **⚠ WARNING**

**Wet grass or leaves can cause serious injury if you slip and contact the blade.**

**Mow only in dry conditions.**

- Clean under the mower housing after each mowing; refer to Cleaning under the Mower Housing (page 21).
- Keep the engine in good running condition.
- Clean the air filter frequently. Mulching stirs up more clippings and dust which clogs the air filter and reduces engine performance.
- Set the engine speed to the fastest position for the best cutting results.

### **⚠ WARNING**

**Operating a machine with its engine running at a speed greater than the factory setting can cause the machine to throw a part of the blade or engine your direction or in the direction of bystanders, resulting in serious personal injury or death.**

- Do not change the engine speed setting.
- If you suspect the engine speed is faster than normal, contact an Authorized Service Dealer.

### Cutting Grass

- Grass grows at different rates at different times of the year. In the summer heat, it is best to cut grass at the 64 mm (2-1/2 inch), 76 mm (3 inch), or 89 mm (3-1/2

inch) cutting-height settings. Cut only about a third of the grass blade at a time. Do not cut below the 64 mm (2-1/2-inch) setting unless the grass is sparse or it is late fall when grass growth begins to slow down.

- When cutting grass over 15 cm (6 inches) tall, first mow at the highest cutting height setting and walk slower; then mow again at a lower setting for the best lawn appearance. If the grass is too long and the leaves clump on top of the lawn, the machine may plug and cause the engine to stall.
- Alternate the mowing direction. This helps disperse the clippings over the lawn for even fertilization.

If the finished lawn appearance is unsatisfactory, try one or more of the following:

- Sharpen the blade.
- Walk at a slower pace while mowing.
- Raise the cutting height on your machine.
- Cut the grass more frequently.
- Overlap cutting swaths instead of cutting a full swath with each pass.
- Set the cutting height on the front wheels one notch lower than the rear wheels. For example, set the front wheels at 64 mm (2-1/2 inches) and the rear wheels at 76 mm (3 inches).

## **Cutting Leaves**

- After cutting the lawn, ensure that half of the lawn shows through the cut leaf cover. You may need to make more than one pass over the leaves.
- For light leaf coverage, set all the wheels at the same cutting height setting.
- If there are more than 12.7 cm (5 inches) of leaves on the lawn, set the front cutting height 1 or 2 notches higher than the rear cutting height. This makes it easier to feed the leaves under the mower housing.
- Slow down your mowing speed if the machine does not cut the leaves finely enough.



# Maintenance

**Note:** Determine the left and right sides of the machine from the normal operating position.

## Recommended Maintenance Schedule(s)

Maintenance Service Interval	Maintenance Procedure
After the first 8 hours	<ul style="list-style-type: none"><li>• Change the engine oil.</li></ul>
After the first 25 hours	<ul style="list-style-type: none"><li>• Tighten any loose fasteners.</li></ul>
Before each use or daily	<ul style="list-style-type: none"><li>• Check the engine-oil level.</li><li>• Inspect the mower blades for wear or damage.</li><li>• Remove grass clippings and dirt from under the housing.</li><li>• Check the stopping time of the blade brake. The blade must stop within 3 seconds of releasing the blade-control bar; if it does not, contact an Authorized Service Dealer for repair.</li><li>• Check for loose or missing fasteners on the engine.</li><li>• Check for fuel or oil leaks.</li><li>• Check or clean the recoil starter and the air-intake screen.</li></ul>
Every 25 hours	<ul style="list-style-type: none"><li>• Clean the foam pre-cleaner (more frequently in dusty conditions).</li></ul>
Every 50 hours	<ul style="list-style-type: none"><li>• Change the engine oil (more frequently in dusty conditions).</li><li>• Sharpen or replace the blade. Maintain it more frequently if the edge dulls quickly in rough or in sandy conditions.</li></ul>
Every 100 hours	<ul style="list-style-type: none"><li>• Inspect, clean, and adjust the spark plug gap; replace the spark plug if necessary.</li><li>• Tighten any loose fasteners.</li><li>• Check or clean the recoil starter and the air-intake screen.</li></ul>
Every 200 hours	<ul style="list-style-type: none"><li>• Have an authorized engine servicing dealer check for leaks in the fuel system and/or a deteriorating fuel hose. Replace parts if necessary.</li></ul>
Every 300 hours	<ul style="list-style-type: none"><li>• Replace the paper air filter (more frequently in dusty conditions).</li><li>• Clean the cylinder and the cylinder-head fins.</li><li>• Have an authorized engine servicing dealer check and adjust the engine idle speed.</li><li>• Have an authorized engine servicing dealer clean the combustion chamber.</li><li>• Have an authorized engine servicing dealer check and adjust the valve clearance.</li><li>• Have an authorized engine servicing dealer clean and lap the valve seating surface.</li></ul>

**Important:** Refer to your engine operator's manual for additional maintenance procedures.

### **▲ CAUTION**

If you leave the wire on the spark plug, someone could accidentally start the engine and seriously injure you or bystanders.

Disconnect the wire from the spark plug before you do any maintenance. Set the wire aside so that it does not accidentally contact the spark plug.

# Engine Maintenance

## Servicing the Air Cleaner

**Service Interval:** Every 25 hours—Clean the foam pre-cleaner (more frequently in dusty conditions).

Every 300 hours—Replace the paper air filter (more frequently in dusty conditions).

**Important:** Do not operate the engine without the air filter assembly in place; otherwise, extreme engine damage will occur.

1. Stop the engine and wait for all moving parts to stop.
2. Disconnect the wire from the spark plug.
3. Loosen the screw on the air-cleaner cover (Figure 17).

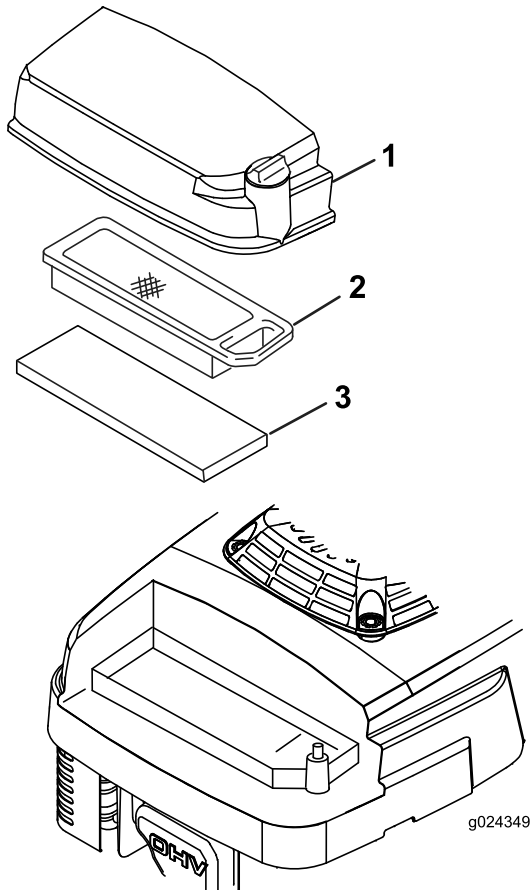

Figure 17

1. Air-cleaner cover
2. Paper air filter
3. Foam pre-cleaner

4. Remove the cover and clean it thoroughly.
5. Remove and inspect the paper air filter (Figure 17), and replace it if it is excessively dirty.

**Important:** Do not try to clean a paper filter.

6. Remove the foam pre-cleaner (Figure 17) and wash it with a mild detergent and water, then blot it dry.

7. Install the foam pre-cleaner.
8. Install the paper air filter.
9. Install the cover and secure it with the screw.

## Changing the Engine Oil

**Service Interval:** After the first 8 hours

Every 50 hours

1. Run the engine to warm the engine oil.

**Note:** Warm oil flows better and carries more contaminants.

### ⚠ WARNING

**Oil may be hot after engine has been run, and contact with hot oil can cause severe personal injury.**

**Avoid contacting the hot engine oil when you drain it.**

2. Stop the engine and wait for all moving parts to stop.
3. Disconnect the wire from the spark plug.
4. Drain the gasoline from the fuel tank.
5. Place a suitable drain pan under the dipstick/oil drain.
6. Clean around the dipstick.
7. Remove the dipstick by rotating the cap counterclockwise and pulling it out.
8. Tip the machine onto its **right** side (air filter up) to drain the oil into the drain pan.
9. After draining the oil, return the machine to the operating position.
10. Fill the crankcase to the Full mark on the dipstick with fresh oil; refer to 3 Filling the Crankcase with Oil (page 10).
11. Insert the dipstick into the filler neck and rotate the cap clockwise until it is tight.
12. Wipe up any spilled oil.
13. Recycle the used oil according to local codes.

# Servicing the Spark Plug

**Service Interval:** Every 100 hours—Inspect, clean, and adjust the spark plug gap; replace the spark plug if necessary.

Use an **NGK BPR5ES** spark plug or equivalent.

1. Stop the engine and wait for all moving parts to stop.
2. Disconnect the wire from the spark plug.
3. Clean around the spark plug.
4. Remove the spark plug from the cylinder head.

**Important:** Replace a cracked, fouled, or dirty spark plug. Do not clean the electrodes because grit entering the cylinder can damage the engine.

5. Set the gap on the plug to 0.76 mm (0.030 inch) (Figure 18).

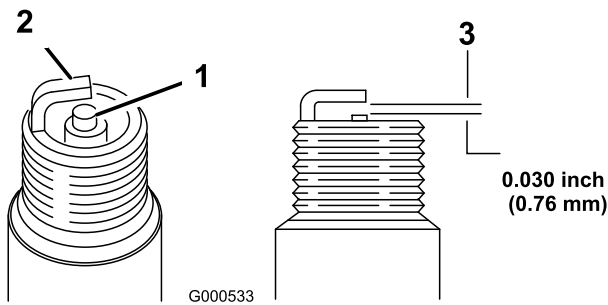

**Figure 18**

1. Center-electrode insulator
2. Side electrode
3. Air gap (not to scale)

6. Carefully install the spark plug by hand (to avoid cross threading) until it is hand tight.
7. Tighten the spark plug to 23 N-m (2.3 kgf-m, 17 ft-lb).

**Important:** A loose spark plug can become very hot and can damage the engine; overtightening a spark plug may damage the threads in the cylinder head.

8. Connect the wire to the spark plug.

# Drive System Maintenance

## Adjusting the Self-propel Drive

**Note:** If the machine is new, does not self-propel, or tends to creep forward, adjust the drive cable.

1. Move the machine outside and onto a paved surface near a solid wall to safely prevent the machine from moving forward while the engine is running.
2. Position the machine with the front tires against the wall.

**Note:** Ensure that the area is well ventilated and clear of debris that could be thrown by the machine.

3. Start the engine; refer to Starting the Engine (page 13).
4. Pull the self-propel-drive bar to the handle.

**Note:** The wheels should start to turn as the self-propel-drive bar just touches the handle.

5. Shut off the engine.
6. If you must adjust the machine, do one of the following:

- If the wheels do not spin when you engage the self-propel-drive bar, the traction belt is too loose. Rotate the wheel-drive-control knob (Figure 19) clockwise 1 turn and repeat steps 3 through 5.

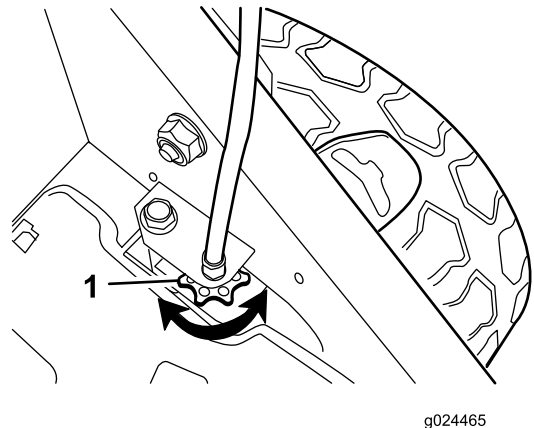

**Figure 19**

1. Wheel-drive-control knob

- If the wheels spin before you fully engage the self-propel-drive bar, the traction belt is too tight. Rotate the wheel-drive-control knob (Figure 19) counterclockwise 1 turn and repeat steps 3 through 5.

7. For a new traction belt, rotate the wheel-drive-control knob clockwise 1 additional turn to allow for stretching of the belt during the break-in period.

**Note:** You can skip this step if you are adjusting a used belt.

# Blade Maintenance

## Maintaining the Blade

Always mow with a sharp blade. A sharp blade cuts cleanly and without tearing or shredding the grass blades.

1. Stop the engine and wait for all moving parts to stop.
2. Disconnect the wire from the spark plug.
3. Drain the gasoline from the fuel tank.
4. Tip the machine onto its **right** side (air cleaner up) as shown in Figure 20.

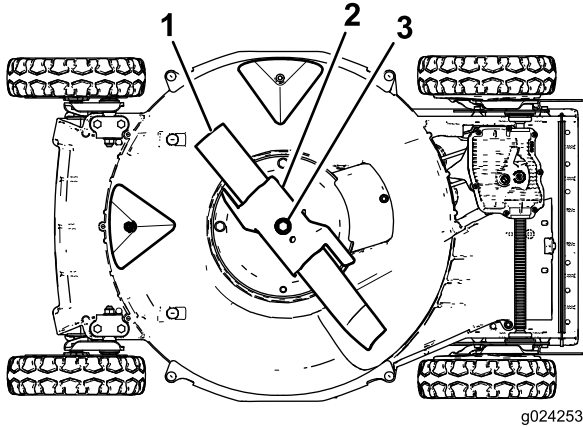

Figure 20

1. Blade
2. Accelerator
3. Blade bolt and lock washer

## Inspecting the Blade

**Service Interval:** Before each use or daily—Inspect the mower blades for wear or damage.

Carefully examine the blade for sharpness and wear, especially where the flat and the curved parts meet (Figure 21A). Because sand and abrasive material can wear away the metal that connects the flat and curved parts of the blade, check the blade before using the machine. If you notice a slot or wear (Figure 21B and Figure 21C), replace the blade; refer to Removing the Blade (page 20).

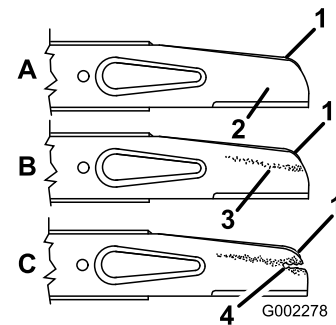

Figure 21

1. Sail
2. Flat part of the blade
3. Wear
4. Slot formed

**Note:** For the best performance, install a new blade before the mowing season begins. During the year, file down any small nicks to maintain the cutting edge.

### **⚠ DANGER**

A worn or damaged blade can break, and a piece of the blade could be thrown in your direction or in the direction of bystanders, resulting in serious personal injury or death.

- Inspect the blade periodically for wear or damage.
- Replace a worn or damaged blade.

## Removing the Blade

1. Grasp the end of the blade using a rag or a thickly padded glove.
2. Remove the blade bolt, the lock washer, the accelerator, and the blade (Figure 21).

## Sharpening the Blade

**Service Interval:** Every 50 hours—Sharpen or replace the blade. Maintain it more frequently if the edge dulls quickly in rough or in sandy conditions.

File the top side of the blade to maintain its original cutting angle (Figure 22A) and inner cutting edge radius (Figure 22B). The blade will remain balanced if you remove the same amount of material from both cutting edges.

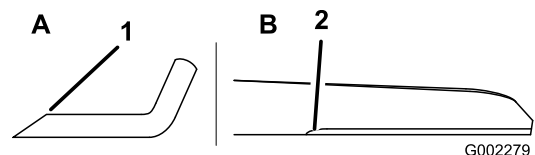

Figure 22

1. Sharpen the blade at this angle only.
2. Maintain the original radius here.

## Balancing the Blade

1. Check the balance of the blade by placing the center hole of the blade over a nail or screwdriver shank clamped horizontally in a vise (Figure 23).

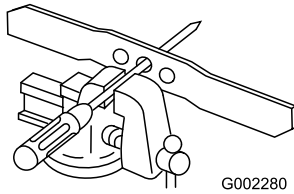

Figure 23

**Note:** You can also check the balance using a commercially manufactured blade balancer.

2. If either end of the blade rotates downward, file that end (not the cutting edge or the end near the cutting edge) until neither end of the blade drops.

## Installing the Blade

1. Install a sharp, balanced Toro blade, the accelerator, the lock washer, and the blade bolt. The sail of the blade must point toward the top of the mower housing for proper installation.

**Note:** Torque the blade bolt to 68 N-m (50 ft-lb).

### **⚠ WARNING**

Operating the machine without the accelerator in place can cause the blade to flex, bend, or break, resulting in serious injury or death to you or to bystanders.

Do not operate the machine without the accelerator in place.

2. Return the machine to the operating position.

## Cleaning

### Cleaning under the Mower Housing

To ensure the best performance, keep the underside of the mower housing clean. Be especially careful to keep the kickers free of debris (Figure 24).

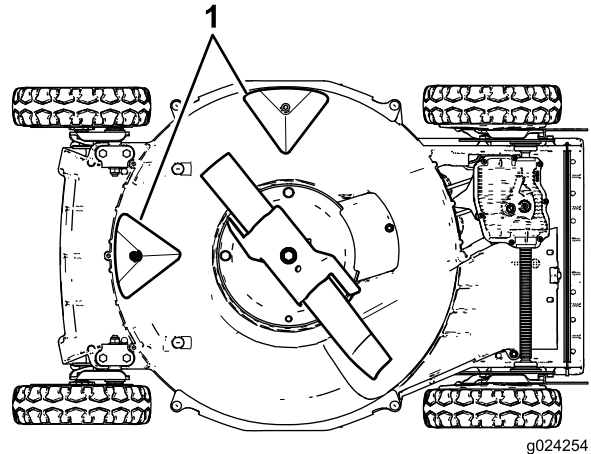

Figure 24

1. Kickers

### Washing Method

**Service Interval:** Before each use or daily

### **⚠ WARNING**

The machine may dislodge material from under the mower housing.

- Wear eye protection.
  - Stay in the operating position (behind the handle) while the engine is running.
  - Do not allow bystanders in the area.
1. Position the machine on a flat concrete or asphalt surface near a garden hose.
  2. Start the engine.
  3. Hold the running garden hose at handle level and direct the water to flow on the ground just in front of the right rear tire (Figure 25).

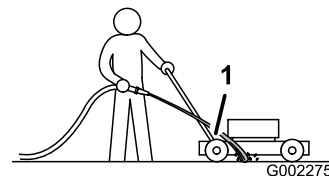

Figure 25

1. Right rear wheel

**Note:** The blade will draw in water and wash out the clippings. Let the water run until you no longer see clippings being washed out from under the mower housing.

4. Stop the engine and wait for all moving parts to stop.
5. Turn off the water.
6. Start the machine and let it run for a few minutes to dry out the mower housing and its components.

## Scraping Method

If washing does not remove all debris from under the mower housing, scrape it clean.

1. Disconnect the wire from the spark plug.
2. Drain the gasoline from the fuel tank.

### **⚠ WARNING**

**Tipping the machine may cause the gasoline to leak from the carburetor or the fuel tank. Gasoline is extremely flammable, highly explosive, and, under certain conditions, can cause personal injury or property damage.**

**Avoid fuel spills by running the engine dry or by removing the gasoline with a hand pump; never siphon.**

3. Tip the machine onto its **right** side (air cleaner up).
4. Remove the dirt and grass clippings with a hardwood scraper. Avoid burrs and sharp edges.
5. Return the machine to the operating position.
6. Connect the wire to the spark plug.

## Storage

To prepare the machine for off-season storage, perform the recommended maintenance procedures; refer to Maintenance (page 17).

Store the machine in a cool, clean, dry place. Cover the machine to keep it clean and protected.

## Preparing the Fuel System

### **⚠ WARNING**

**Gasoline can vaporize if you store it over long periods of time and explode if it comes into contact with an open flame.**

- **Do not store gasoline over long periods of time.**
- **Do not store the machine with gasoline in the fuel tank or the carburetor in an enclosure with an open flame. (For example, a furnace or a water heater pilot light.)**
- **Allow the engine to cool before storing it in any enclosure.**

Empty the gasoline from the fuel tank when mowing for the last time before storing the machine.

1. Run the engine until it stops from running out of gasoline.
2. Choke the engine and start it again.
3. Allow the engine to run until it stops. When you can no longer start the engine, it is sufficiently dry.

## Preparing the Engine

1. While the engine is still warm, change the oil in the crankcase; refer to Changing the Engine Oil (page 18).
2. Remove the spark plug.
3. Using an oil can, add about 30 ml (1 oz) of engine oil to the engine crankcase through the spark-plug hole.
4. Slowly rotate the engine several times by pulling the recoil-start handle to distribute the oil throughout the engine crankcase.
5. Install the spark plug but **do not** connect the wire to the spark plug.

## General Information

1. Clean under the mower housing; refer to Cleaning under the Mower Housing (page 21).
2. Clean any dirt and chaff from the cylinder, cylinder head fins, and blower housing.
3. Remove grass clippings, dirt, and grime from the external parts of the engine, the shrouding, and the top of the mower housing.

4. Check the condition of the blade; refer to Inspecting the Blade (page 20).
5. Service the air cleaner; refer to Servicing the Air Cleaner (page 18).
6. Tighten all nuts, bolts, and screws.
7. Touch up all rusted or chipped paint surfaces with paint available from an Authorized Service Dealer.

## Removing the Machine from Storage

1. Check and tighten all fasteners.
2. Remove the spark plug and spin the engine rapidly using the starter to blow out the excess oil from the cylinder.
3. Clean the spark plug or replace it if it is cracked, broken, or if the electrodes are worn.
4. Install the spark plug; refer to Servicing the Spark Plug (page 19).
5. Perform any needed maintenance procedures; refer to Maintenance (page 17).
6. Fill the fuel in the fuel tank with fresh gasoline.
7. Check the engine-oil level.
8. Connect the wire to the spark plug.

# Troubleshooting

Problem	Possible Cause	Corrective Action
The engine does not start.	<ol style="list-style-type: none"> <li>1. The fuel tank is empty or the fuel system contains stale fuel.</li> <li>2. The wire is not connected to the spark plug.</li> <li>3. The spark plug is pitted, fouled, or the gap is incorrect.</li> </ol>	<ol style="list-style-type: none"> <li>1. Drain and/or fill the fuel tank with fresh gasoline. If the problem persists, contact an Authorized Service Dealer.</li> <li>2. Connect the wire to the spark plug.</li> <li>3. Check the spark plug and adjust the gap if necessary. Replace the spark plug if it is pitted, fouled, or cracked.</li> </ol>
The engine starts hard or loses power.	<ol style="list-style-type: none"> <li>1. The fuel tank contains stale fuel.</li> <li>2. The air filter element is dirty and is restricting the air flow.</li> <li>3. The underside of the mower housing contains clippings and debris.</li> <li>4. The spark plug is pitted, fouled, or the gap is incorrect.</li> <li>5. The engine oil level is low or the oil is dirty.</li> </ol>	<ol style="list-style-type: none"> <li>1. Drain and fill the fuel tank with fresh gasoline.</li> <li>2. Clean the air filter pre-cleaner and/or replace the paper air filter.</li> <li>3. Clean under the mower housing.</li> <li>4. Check the spark plug and adjust the gap if necessary. Replace the spark plug if it is pitted, fouled, or cracked.</li> <li>5. Check the engine oil. Change the oil if it is dirty or add oil if it is low.</li> </ol>
The engine runs rough.	<ol style="list-style-type: none"> <li>1. The wire is not connected to the spark plug.</li> <li>2. The spark plug is pitted, fouled, or the gap is incorrect.</li> <li>3. The air filter element is dirty and is restricting the air flow.</li> </ol>	<ol style="list-style-type: none"> <li>1. Connect the wire to the spark plug.</li> <li>2. Check the spark plug and adjust the gap if necessary. Replace the spark plug if it is pitted, fouled, or cracked.</li> <li>3. Clean the air filter pre-cleaner and/or replace the paper air filter.</li> </ol>
The machine or engine vibrates excessively.	<ol style="list-style-type: none"> <li>1. The blade is bent or is out of balance.</li> <li>2. The blade bolt is loose.</li> <li>3. The underside of the mower housing contains clippings and debris.</li> <li>4. The engine mounting bolts are loose.</li> </ol>	<ol style="list-style-type: none"> <li>1. Balance the blade. If the blade is bent, replace it.</li> <li>2. Tighten the blade bolt.</li> <li>3. Clean the underside of the mower housing.</li> <li>4. Tighten the engine mounting bolts.</li> </ol>
The is an uneven cutting pattern.	<ol style="list-style-type: none"> <li>1. All 4 wheels are not at the same height.</li> <li>2. The blade is dull.</li> <li>3. You are mowing in the same pattern repeatedly.</li> <li>4. The underside of the mower housing contains clippings and debris.</li> </ol>	<ol style="list-style-type: none"> <li>1. Place all 4 wheels at the same height.</li> <li>2. Sharpen and balance the blade.</li> <li>3. Change the mowing pattern.</li> <li>4. Clean under the mower housing.</li> </ol>
The discharge chute plugs up.	<ol style="list-style-type: none"> <li>1. The cutting height is too low.</li> <li>2. You are mowing too fast.</li> <li>3. The grass is wet.</li> <li>4. The underside of the mower housing contains clippings and debris.</li> </ol>	<ol style="list-style-type: none"> <li>1. Raise the cutting height.</li> <li>2. Slow down.</li> <li>3. Allow the grass to dry before mowing.</li> <li>4. Clean under the mower housing.</li> </ol>



**Notes:**

**Notes:**

## International Distributor List

<b>Distributor:</b>	<b>Country:</b>	<b>Phone Number:</b>	<b>Distributor:</b>	<b>Country:</b>	<b>Phone Number:</b>
Agrolanc Kft	Hungary	36 27 539 640	Maquiver S.A.	Colombia	57 1 236 4079
Balama Prima Engineering Equip.	Hong Kong	852 2155 2163	Maruyama Mfg. Co. Inc.	Japan	81 3 3252 2285
B-Ray Corporation	Korea	82 32 551 2076	Mountfield a.s.	Czech Republic	420 255 704 220
Casco Sales Company	Puerto Rico	787 788 8383	Mountfield a.s.	Slovakia	420 255 704 220
Ceres S.A.	Costa Rica	506 239 1138	Munditol S.A.	Argentina	54 11 4 821 9999
CSSC Turf Equipment (pvt) Ltd.	Sri Lanka	94 11 2746100	Norma Garden	Russia	7 495 411 61 20
Cyril Johnston & Co.	Northern Ireland	44 2890 813 121	Oslinger Turf Equipment SA	Ecuador	593 4 239 6970
Cyril Johnston & Co.	Republic of Ireland	44 2890 813 121	Oy Hako Ground and Garden Ab	Finland	358 987 00733
Equiver	Mexico	52 55 539 95444	Parkland Products Ltd.	New Zealand	64 3 34 93760
Femco S.A.	Guatemala	502 442 3277	Perfetto	Poland	48 61 8 208 416
ForGarder OU	Estonia	372 384 6060	Pratoverde SRL.	Italy	39 049 9128 128
G.Y.K. Company Ltd.	Japan	81 726 325 861	Prochaska & Cie	Austria	43 1 278 5100
Geomechaniki of Athens	Greece	30 10 935 0054	RT Cohen 2004 Ltd.	Israel	972 986 17979
Golf international Turizm	Turkey	90 216 336 5993	Riversa	Spain	34 9 52 83 7500
Guandong Golden Star	China	86 20 876 51338	Lely Turfcare	Denmark	45 66 109 200
Hako Ground and Garden	Sweden	46 35 10 0000	Solvart S.A.S.	France	33 1 30 81 77 00
Hako Ground and Garden	Norway	47 22 90 7760	Spypros Stavrinides Limited	Cyprus	357 22 434131
Hayter Limited (U.K.)	United Kingdom	44 1279 723 444	Surge Systems India Limited	India	91 1 292299901
Hydroturf Int. Co Dubai	United Arab Emirates	97 14 347 9479	T-Markt Logistics Ltd.	Hungary	36 26 525 500
Hydroturf Egypt LLC	Egypt	202 519 4308	Toro Australia	Australia	61 3 9580 7355
Irrimac	Portugal	351 21 238 8260	Toro Europe NV	Belgium	32 14 562 960
Irrigation Products Int'l Pvt Ltd.	India	0091 44 2449 4387	Valtech	Morocco	212 5 3766 3636
Jean Heybroek b.v.	Netherlands	31 30 639 4611	Victus Emak	Poland	48 61 823 8369

### European Privacy Notice

#### The Information Toro Collects

Toro Warranty Company (Toro) respects your privacy. In order to process your warranty claim and contact you in the event of a product recall, we ask you to share certain personal information with us, either directly or through your local Toro company or dealer.

The Toro warranty system is hosted on servers located within the United States where privacy law may not provide the same protection as applies in your country.

**BY SHARING YOUR PERSONAL INFORMATION WITH US, YOU ARE CONSENTING TO THE PROCESSING OF YOUR PERSONAL INFORMATION AS DESCRIBED IN THIS PRIVACY NOTICE.**

#### The Way Toro Uses Information

Toro may use your personal information to process warranty claims, to contact you in the event of a product recall and for any other purpose which we tell you about. Toro may share your information with Toro's affiliates, dealers or other business partners in connection with any of these activities. We will not sell your personal information to any other company. We reserve the right to disclose personal information in order to comply with applicable laws and with requests by the appropriate authorities, to operate our systems properly or for our own protection or that of other users.

#### Retention of your Personal Information

We will keep your personal information as long as we need it for the purposes for which it was originally collected or for other legitimate purposes (such as regulatory compliance), or as required by applicable law.

#### Toro's Commitment to Security of Your Personal Information

We take reasonable precautions in order to protect the security of your personal information. We also take steps to maintain the accuracy and current status of personal information.

#### Access and Correction of your Personal Information

If you would like to review or correct your personal information, please contact us by email at [legal@toro.com](mailto:legal@toro.com).

### Australian Consumer Law

Australian customers will find details relating to the Australian Consumer Law either inside the box or at your local Toro Dealer.



# The Toro Total Warranty

Landscape  
Contractor  
Equipment (LCE)

## Conditions and Products Covered

The Toro Company and its affiliate, Toro Warranty Company, pursuant to an agreement between them, jointly promise to the original purchaser to repair the Toro Products listed below if defective in materials or workmanship.

The following time periods apply from the date of purchase by the original owner:

Products	Warranty Period
Walk Behind Mowers	
53 cm Mowers – Residential use <sup>1</sup>	2 years
53 cm Mowers – Commercial use	1 year
76 cm Mowers – Residential use <sup>1</sup>	2 years
76 cm Mowers – Commercial use	1 year
Mid-Size Walk-Behind Mowers	2 years
• Engine	2 years <sup>2</sup>
Grand Stand® Mowers	5 years or 1,200 hours <sup>3</sup>
• Engine	2 years
• Frame	Lifetime (original owner only) <sup>4</sup>
Z Master® 2000 Series Mowers	4 years or 500 hours <sup>3</sup>
• Engine	2 years <sup>2</sup>
• Frame	Lifetime (original owner only) <sup>4</sup>
Z Master® 3000 Series Mowers	5 years or 1,200 hours <sup>3</sup>
• Engine	2 years <sup>2</sup>
• Frame	Lifetime (original owner only) <sup>4</sup>
Z Master® 5000 and 6000 Series Mowers	5 years or 1,200 hours <sup>3</sup>
• Engine	2 years <sup>2</sup>
• Frame	Lifetime (original owner only) <sup>4</sup>
Z Master® 7000 Series Mowers	5 years or 1,200 hours <sup>3</sup>
• Engine	2 years <sup>2</sup>
• Frame	Lifetime (original owner only) <sup>4</sup>
All Mowers	
• Battery	2 years
• Attachments	2 years

<sup>1</sup>Residential use means use of the product on the same lot as your home. Use at more than one location is considered commercial use and the commercial warranty would apply.

<sup>2</sup>Some engines used on Toro LCE Products are warranted by the engine manufacturer.

<sup>3</sup>Whichever occurs first.

<sup>4</sup>Lifetime Frame Warranty - If the main frame, consisting of the parts welded together to form the tractor structure that other components such as the engine are secured to, cracks or breaks in normal use, it will be repaired or replaced under warranty at no cost for parts and labor. Frame failure due to misuse or abuse and failure or repair required due to rust or corrosion are not covered.

This warranty includes the cost of parts and labor, but you must pay transportation costs.

## Instructions for Obtaining Warranty Service

If you think that your Toro Product contains a defect in materials or workmanship, follow this procedure:

1. Contact your seller to arrange service of the product. If for any reason it is impossible for you to contact your seller, you may contact any Toro Authorized Distributor to arrange service.
2. Bring the product and your proof of purchase (sales receipt) to the Service Dealer.
3. If for any reason you are dissatisfied with the Service Dealer's analysis or with the assistance provided, contact us at:

RLC Customer Care Department

Toro Warranty Company  
8111 Lyndale Avenue South  
Bloomington, MN 55420-1196  
001-952-948-4707

See attached Distributor List.

## Owner Responsibilities

You must maintain your Toro Product by following the maintenance procedures described in the *Operator's Manual*. Such routine maintenance, whether performed by a dealer or by you, is at your expense.

## Items and Conditions Not Covered

There is no other express warranty except for special emission system coverage and engine warranty coverage on some products. This express warranty does not cover the following:

- Cost of regular maintenance service or parts, such as filters, fuel, lubricants, oil changes, spark plugs, air filters blade sharpening or worn blades, cable/linkage adjustments, or brake and clutch adjustments
- Components failing due to normal wear
- Any product or part which has been altered or misused or neglected and requires replacement or repair due to accidents or lack of proper maintenance
- Pickup and delivery charges
- Repairs or attempted repairs by anyone other than an Authorized Toro Service Dealer
- Repairs necessary due to failure to follow recommended fuel procedure (consult *Operator's Manual* for more details)
  - Removing contaminants from the fuel system is not covered
  - Use of old fuel (more than one month old) or fuel which contains more than 10% ethanol or more than 15% MTBE
  - Failure to drain the fuel system prior to any period of non-use over one month

## General Conditions

The purchaser is covered by the national laws of each country. The rights to which the purchaser is entitled with the support of these laws are not restricted by this warranty.