



Count on it.

Operator's Manual

RT600 Traction Unit

Model No. 25430A—Serial No. 31500001 and Up

Model No. 25430C—Serial No. 31500001 and Up

Model No. 25430W—Serial No. 31500001 and Up

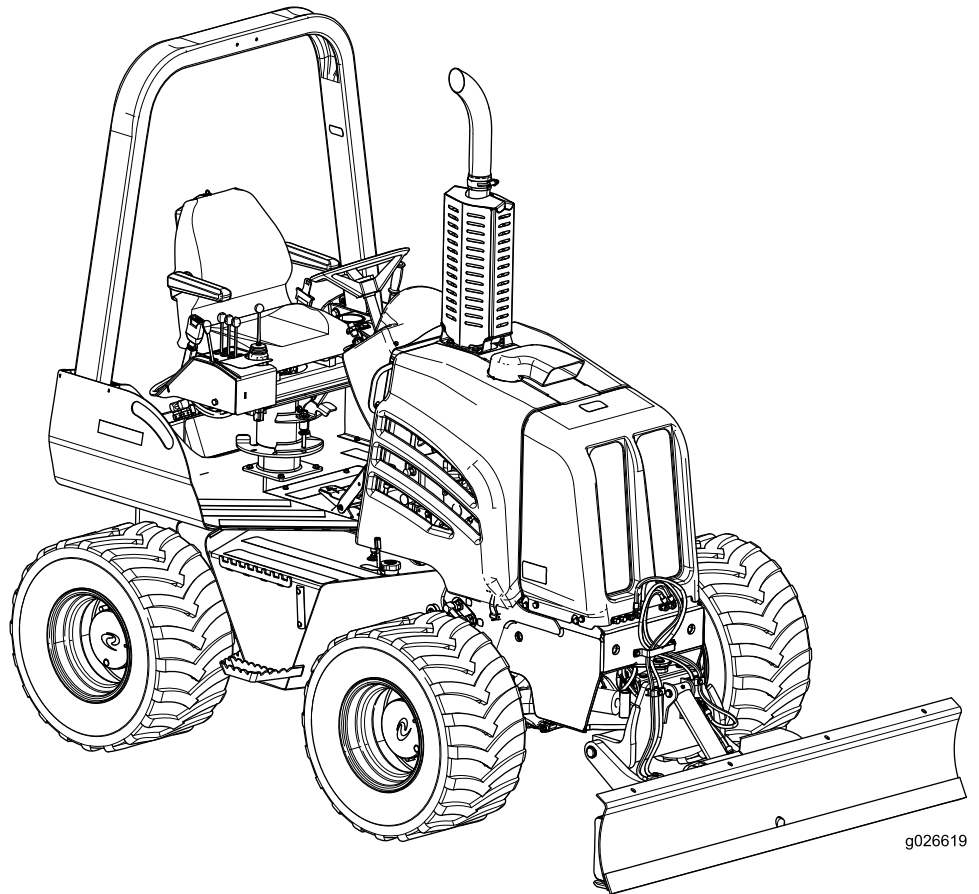

g026619



▲ WARNING

CALIFORNIA Proposition 65 Warning

This product contains a chemical or chemicals known to the State of California to cause cancer, birth defects, or reproductive harm.

The engine exhaust from this product contains chemicals known to the State of California to cause cancer, birth defects, or other reproductive harm.

Because in some areas there are local, state, or federal regulations requiring that a spark arrester be used on the engine of this machine, a spark arrester is available as an option. If you require a spark arrester, contact your Authorized Toro Service Dealer.

Important: It is a violation of California Public Resource Code Section 4442 to use or operate the engine on any forest-covered, brush-covered, or grass-covered land without a spark arrester muffler maintained in working order, or the engine constricted, equipped, and maintained for the prevention of fire. Other states or federal areas may have similar laws.

Genuine Toro spark arresters are approved by the USDA Forestry Service.

The enclosed Engine Owner's Manual is supplied for information regarding the US Environmental Protection Agency (EPA) and the California Emission Control Regulation of emission systems, maintenance, and warranty. Replacements may be ordered through the engine manufacturer.

Introduction

This machine is designed to dig trenches in soil to bury cabling and piping for various applications. It is not intended to cut rock, wood, or any other material other than soil.

Read this information carefully to learn how to operate and maintain your product properly and to avoid injury and product damage. You are responsible for operating the product properly and safely.

You may contact Toro directly at www.Toro.com for product and accessory information, help finding a dealer, or to register your product.

Whenever you need service, genuine Toro parts, or additional information, contact an Authorized Toro Service Dealer or Toro Customer Service and have the model and serial numbers of your product ready. Figure 1 illustrates the location of the model and serial numbers on the product. Write the numbers in the space provided.

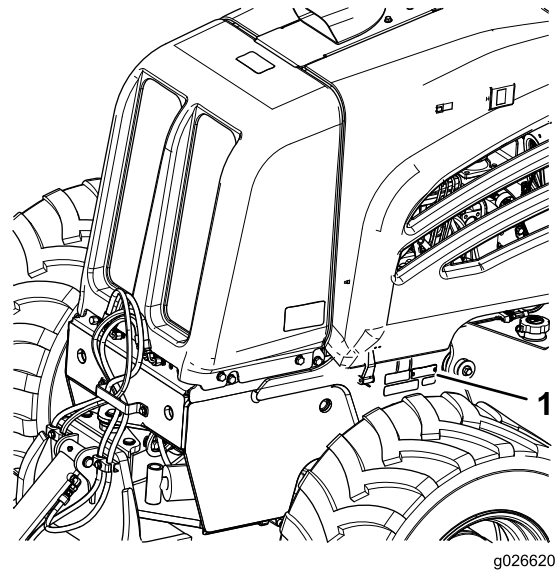

Figure 1

1. Location of the model and serial number plate

Model No. _____
Serial No. _____

This manual identifies potential hazards and has safety messages identified by the safety alert symbol (Figure 2), which signals a hazard that may cause serious injury or death if you do not follow the recommended precautions.



Figure 2

1. Safety alert symbol

This manual uses 2 words to highlight information.

Important calls attention to special mechanical information and **Note** emphasizes general information worthy of special attention.

Contents

Safety	3
.....	4
Electrical Line Safety	6
Gas Line Safety	6
Communication Line Safety	6
Water Line Safety	6
Safety and Instructional Decals	7
Product Overview	14
Controls	15
Instrument Cluster.....	15

Safety

Improperly using or maintaining this machine can result in injury. To reduce the potential for injury, comply with these safety instructions and always pay attention to the safety alert symbol (Figure 2), which means **Caution, Warning, or Danger**—personal safety instruction. **Failure to comply with the instruction may result in personal injury or death.**

Important: This machine was manufactured according to the appropriate regulatory standards in effect at the time of manufacture. Modifying this machine in any way may cause it to be out of compliance with those standards and with the instructions in this *Operator's Manual*. Modifications to this machine should be made only by an Authorized Toro Service Dealer.

⚠ WARNING

Welding, cutting, or drilling cast ductile iron parts of the machine could cause them to break during operation, which in turn could result in injury or death.

Do not weld, cut, or drill to repair or to attach items to cast ductile iron parts on this machine.

Always follow all safety instructions to avoid serious injury or death.

You can prevent and are responsible for injuries occurring to yourself and to others and for damage to property.

Do not use this machine for applications other than those which are described in this manual.

Before operating this machine for the purpose of trenching, drilling, or other construction work, it is your responsibility to know where all utility lines are buried in the project area and to avoid them.

Always ensure that all local utility companies mark the location of their lines. In the USA and Canada, call a “One-call System Directory” service. In the USA, call 811 or your local number. If you do not know your local number, call the national number (USA and Canada only) at 1-888-258-0808. Also, contact any utility companies that are not participants of the “One-call System Directory” service.

Check with local authorities for all laws and regulations that require you to locate and avoid existing utilities.

Refer to the following table for the proper utility line and the corresponding utility line color (USA and Canada only):

Traction Controls	18
Attachment Control Panel	19
Operator Seat and Seat Belt	20
Specifications	21
Attachments/Accessories	21
Operation	22
Preparing for Work	22
Adding Fuel to the Engine	22
Checking the Engine Oil Level	23
Checking the Hydraulic Fluid Level	24
Inspecting the Machine Daily	25
Starting the Engine	25
Setting the Engine Speed	25
Stopping the Engine	26
Breaking in a New or Rebuilt Engine	26
Operating the Machine in Extreme Conditions	26
Operating the Parking Brake	27
Driving and Stopping the Machine	27
Operating the Transmission	28
Preparing to Operate the Machine	29
Using the Backfill Blade	29
Transporting the Machine	30
Completing the Work for the Day	31
Completing the Project	31
Maintenance	32
Recommended Maintenance Schedule(s)	32
Premaintenance Procedures	33
General Safety	33
Lubrication	33
Greasing the Machine	33
Engine Maintenance	35
Accessing the Engine	35
Servicing the Engine Oil and Filter	37
Servicing the Air-cleaner System	39
Fuel System Maintenance	42
Servicing the Fuel System	42
Electrical System Maintenance	45
Maintaining the Battery	45
Drive System Maintenance	48
Servicing the Tires	48
Servicing the Axles and the Transmission	49
Cooling System Maintenance	54
Servicing the Cooling System	54
Belt Maintenance	58
Servicing the Engine Drive Belt	58
Replacing the Engine Drive Belt	59
Hydraulic System Maintenance	61
Servicing the Hydraulic System	61
ROPS Maintenance	64
Checking and Servicing the ROPS	64
Cleaning	65
Removing Dirt and Debris from the Machine	65
Storage	66
Preparing for Seasonal Storage	66
Troubleshooting	67

Utility Line	Color
Electric	Red
Telecommunication, alarm or signal, cables, or conduit	Orange
Natural gas, oil, steam, petroleum, or other gaseous or flammable material	Yellow
Sewer and drain	Green
Drinking water	Blue
Reclaimed water, irrigation, and slurry lines	Purple
Temporary survey markings	Pink
Proposed excavation limits	White

After locating all the utility lines, carefully dig a hole to the utility line to verify the location and the depth of the line.

Training

- Read the *Operator's Manual* and other training material. If the operator(s) or mechanic(s) cannot read English, it is the owner's responsibility to explain this material to them.
- Become familiar with the safe operation of the equipment, operator controls, and safety signs.
- All operators and mechanics should be trained. The owner is responsible for training the users.
- Never let children or untrained people operate or service the equipment. Local regulations may restrict the age of the operator.
- Ensure that you understand the hand signals used on the job site. Follow the instructions of the signal person.

Preparation

- Before using the machine, have the area marked for underground utilities, and do not dig in marked areas. Also, be aware of the location of objects and structures that may not be marked, such as underground storage tanks, wells, and septic systems.
- Evaluate the terrain to determine what accessories and attachments are needed to properly and safely perform the job. Use only accessories and attachments approved by the manufacturer.
- Mark the job site clearly and keep bystanders away.
- Review the job site hazards, safety and emergency procedures, and personnel responsibilities with all workers before beginning the work.
- Wear appropriate clothing, including hard hat, safety glasses, long pants, safety shoes, and hearing protection; some jobs may also require that you wear a reflective vest and/or a respirator. Secure long hair, loose clothing, and jewelry to prevent them from getting tangled in moving parts.

- Before operating the machine with an attachment, ensure that the attachment is properly installed.
- Use extra care when handling fuels. They are flammable and vapors are explosive.
 - Use only an approved container.
 - Do not remove the fuel cap or add fuel with the engine running. Allow the engine to cool before fueling. Do not smoke near the machine while the engine is running.
 - Do not refuel or drain the machine indoors.
- Check that the operator's presence controls, safety switches, and shields are attached and functioning properly. Do not operate the machine unless these controls, switches, and shields are functioning properly.

General Operation

- Always wear a seat belt when operating a machine with a ROPS.
- Do not run an engine in an enclosed area.
- Do not operate the machine without the guards securely in place. Ensure that all interlocks are attached, adjusted properly, and functioning properly.
- Decrease the ground speed of the machine and use caution when making turns and crossing roads and sidewalks.
- Do not operate the machine while under the influence of alcohol or drugs.
- Ensure that the area is clear of other people before operating the machine. Stop the machine if anyone enters the area.
- Excessive vibration from a trencher or a plow can cause a trench, an overhang, or a high bank to collapse, resulting in possible injury or death.
- If your view of the work area is not clear, always have a signal person direct the movement of the machine.
- Do not leave a running machine unattended. Stop the engine and remove the key whenever you leave the machine.
- Use only Toro-approved attachments. Attachments can change the stability and the operating characteristics of the machine.
- Watch for traffic when operating the machine near or across roadways.
- Ensure that you operate the machine in areas where there are no obstacles in close proximity to you. Failure to maintain an adequate distance from trees, walls, and other barriers while operating the machine may result in injury and/or damage. Operate the machine only in areas where there is sufficient clearance for you to safely maneuver the product.

- Locate the pinch point areas marked on the machine and attachments, and keep hands and feet away from these areas.
- Lightning can cause severe injury or death. If lightning is seen or thunder is heard in the area, do not operate the machine; seek shelter.
- Check for overhead clearances (i.e., branches, doorways, electrical wires) before driving under any objects, and do not contact them.
- Move all attachments into the transport position.

Slope Operation

Slopes are a major factor related to loss-of-control and tip-over accidents, which can result in severe injury or death. All slopes require extra caution.

- Avoid operating this machine on slopes, if possible.
- Keep all movements on slopes slow and gradual. Do not make sudden changes in speed or direction.
- Avoid starting or stopping the machine on a slope. If the machine loses traction, keep the heavy end of the machine uphill and proceed slowly, straight down the slope.
- Avoid turning the machine on slopes. If you must turn, turn slowly and keep the heavy end of the machine uphill.
- Do not operate the machine near drop-offs, ditches, or embankments. The machine could suddenly turn over if a tire goes over the edge of a cliff or ditch, or if an edge caves in.

Rollover Protection Structure (ROPS) System

- Before operating a machine with a ROPS (rollover protection structure), ensure that the seat belt is in good condition and is securely attached to the machine.
- Inspect the ROPS at the interval recommended in this manual or when the ROPS has been in an accident.
- Repair a damaged ROPS using only genuine Toro replacement parts; do not repair or modify the ROPS.
- Check carefully for overhead clearances (i.e. branches, doorways, electrical wires) before driving under any objects and do not contact them.
- Do not remove the ROPS except when servicing or replacing it.
- Do not add weight to the machine that exceeds the gross weight displayed on the ROPS label.

Transporting Safety

When you transport the machine to or from the job site, observe the following safety precautions:

- Do not carry passengers on the machine.
- Keep all bystanders away while you are moving the machine.
- Use care when loading or unloading the machine into a trailer or truck.
- Watch for traffic when you are crossing roadways with the machine.

Maintenance and Storage

- Lower the attachment(s), stop the engine, wait for all moving parts to stop, and remove the key whenever you adjust, clean, or repair the machine.
- Do not touch parts that may be hot from operation. Allow them to cool before attempting to maintain, adjust, or service the machine.
- Clean debris from attachments, drives, mufflers, and engine to help prevent fires. Clean up oil and fuel spills.
- Let the engine cool before storing, and do not store the machine near an open flame.
- Park the machine on level ground.
- Do not allow untrained personnel to service the machine.
- Use jack stands to support components when required.
- Carefully release pressure from components with stored energy.
- Keep hands and feet away from moving parts. If possible, do not make adjustments with the engine running.
- Keep all parts in good working condition and all hardware tightened. Replace all worn or damaged decals.
- Keep nuts and bolts tight. Keep all equipment in good condition.
- Do not tamper with safety devices.
- Keep the machine clean and free of debris.
- Clean up oil or fuel spills.
- Use extra care when handling fuels. They are flammable and vapors are explosive.
 - Use only an approved container.
 - Do not remove the fuel cap or add fuel when the engine is running. Allow the engine to cool before refueling. Do not smoke.
 - Do not refuel the machine indoors.
 - Do not drain the fuel indoors.
 - Do not store the machine or a fuel container inside where there is an open flame, such as near a water heater or furnace.
 - Do not fill a container while it is inside a vehicle, trunk, pickup bed, or any surface other than the ground.
 - Keep container nozzle in contact with the tank during filling.
- Use only genuine Toro replacement parts.
- Disconnect the battery before making any repairs. Disconnect from the negative battery terminal first and

from the positive last. Connect to the positive first and to the negative last.

- Charge the battery in an open well ventilated area, away from spark and flames. Unplug the charger before connecting or disconnecting it from the battery. Wear protective clothing and use insulated tools.
- Battery acid is poisonous and can cause burns. Avoid contact with skin, eyes, and clothing. Protect your face, eyes, and clothing when working with a battery.
- Battery gases can explode. Keep cigarettes, sparks, and flames away from the battery.
- Keep your body and hands away from pin hole leaks or nozzles that eject high-pressure hydraulic fluid. Use cardboard or paper to find hydraulic leaks; never use your hands. Hydraulic fluid escaping under pressure can penetrate skin and cause injury, requiring surgery within a few hours by a qualified surgeon; otherwise, gangrene may result.
- Allow the machine to cool before storing it.

Electrical Line Safety

⚠ WARNING

If you leave the seat of the machine or touch any part of the machine when it is charged with electricity, serious injury or death could result.

Do not leave the seat of the machine if the machine is charged with electricity.

Note: Immediately contact the proper emergency and utility authorities to secure the area in the case that the machine is charged and you cannot leave the seat of the machine.

Note: It is possible to strike a utility line without the machine becoming charged.

- It is likely (but not always the case) that the power-source interrupter or breaker will trip, but to ensure your safety, consider that the machine may be conducting electricity.
- Do not attempt to leave the machine.

Note: You will be safe as long as you do not leave the seat of the machine.

- Touching any part of the machine while contacting the ground may electrically ground you.
- Do not allow another individual to touch or approach the machine when it is charged.

Gas Line Safety

⚠ WARNING

If you damage a gas line, an immediate explosion and fire hazard could occur. Leaking gas is both flammable and explosive and may cause serious injury or death.

- Do not smoke while operating the machine.
- Shut off the machine and remove the key.
- Remove all individuals from the work area.
- Immediately contact the proper emergency and utility authorities to secure the area.

Communication Line Safety

⚠ CAUTION

If you damage the fiber-optic cable and look into the exposed highly-intense light, you may harm your eyes.

- Shut off the machine and remove the key.
- Remove all individuals from the work area.
- Immediately contact the proper emergency and utility authorities to secure the area.

Water Line Safety

If you damage a water line, a potential flood hazard could occur.

- Shut off the machine and remove the key.
- Remove all individuals from the work area.
- Immediately contact the proper emergency and utility authorities to secure the area.

Safety and Instructional Decals



Safety decals and instructions are easily visible to the operator and are located near any area of potential danger. Replace any decal that is damaged or lost.

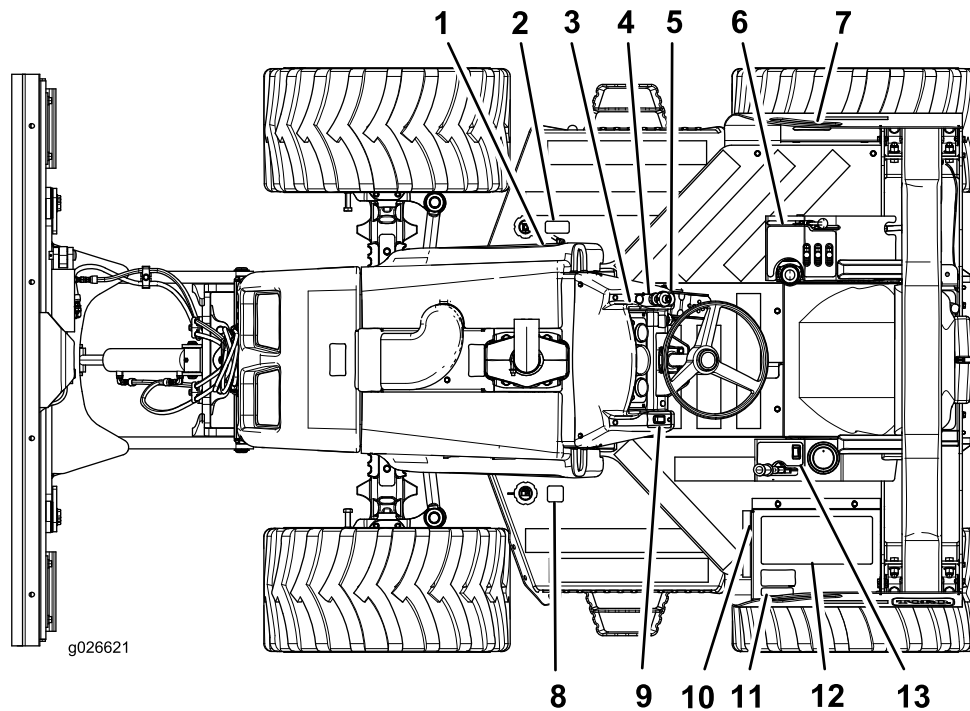

Figure 3
Decal Map (Top view)

- | | | | |
|------------------------------------|-------------------|--------------------|--------------------|
| 1. Decal 125-8470 (under the hood) | 5. Decal 125-8472 | 9. Decal 125-8475 | 13. Decal 125-6698 |
| 2. Decal 125-8483 | 6. Decal 125-6695 | 10. Decal 125-8473 | |
| 3. Decal 125-6683 | 7. Decal 125-8471 | 11. Decal 125-6691 | |
| 4. Decal 125-8484 | 8. Decal 125-8478 | 12. Decal 125-6699 | |

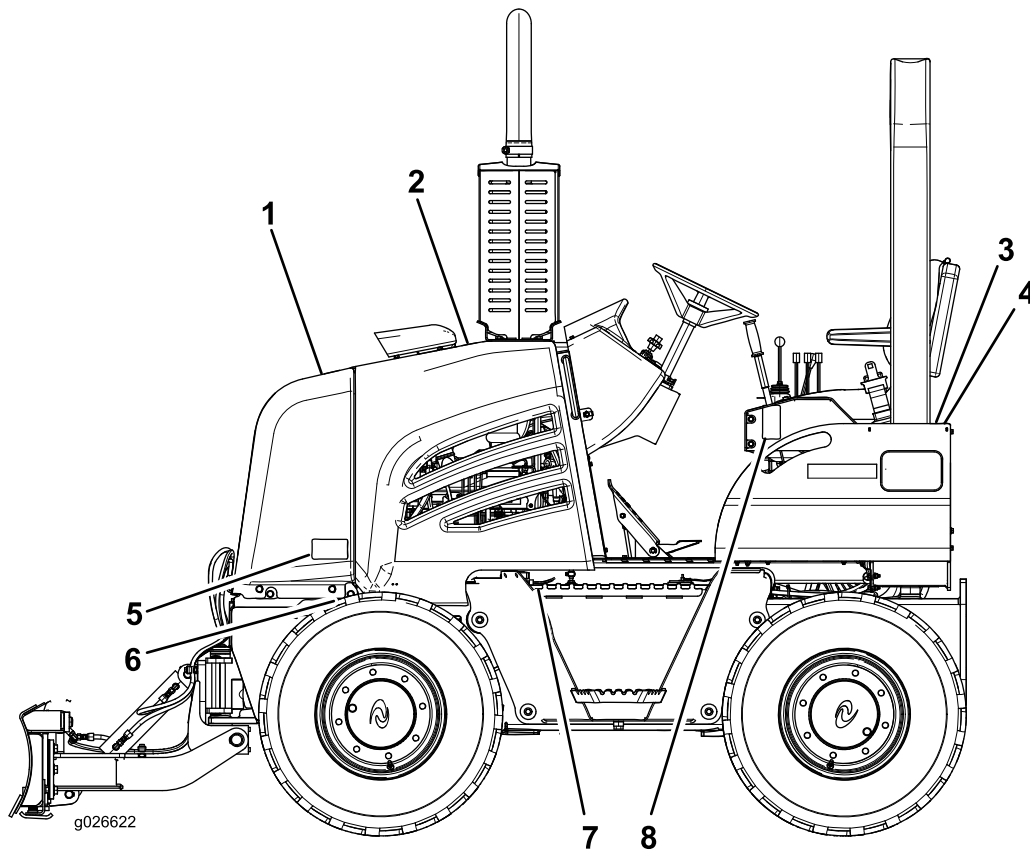

Figure 4

Decal Map (Left-side view)

- | | | | |
|-------------------|-----------------------|-------------------|-------------------|
| 1. Decal 125-8479 | 3. Decal 125-8482 (2) | 5. Decal 125-8478 | 7. Decal 125-6689 |
| 2. Decal 125-4963 | 4. Decal 125-8481 (2) | 6. Decal 117-2718 | 8. Decal 125-8480 |

CALIFORNIA SPARK ARRESTER WARNING

Operation of this equipment may create sparks that can start fires around dry vegetation. A spark arrester may be required. The operator should contact local fire agencies for laws or regulations relating to fire prevention requirements. 117-2718

117-2718



125-4963

1. Warning—do not touch hot surfaces.

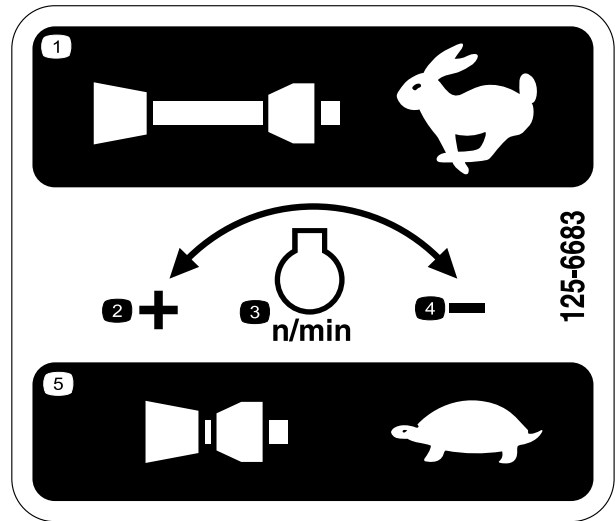

125-6683

- | | |
|-------------------------------|------------------------------|
| 1. Pull out for fastest speed | 4. Decrease speed |
| 2. Increase speed | 5. Push in for slowest speed |
| 3. Engine speed | |

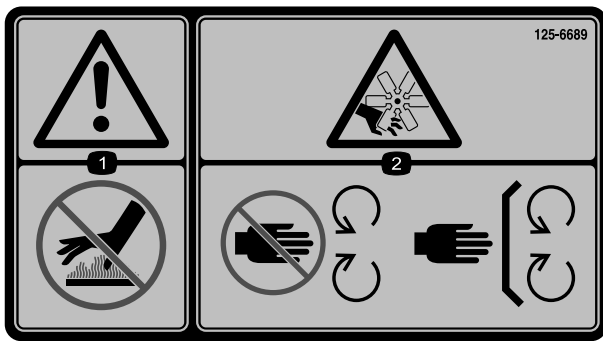

125-6689

1. Warning—keep away from hot surfaces.
2. Cutting/dismemberment hazard, fan—keep away from moving parts; keep all guards and safety devices in place.

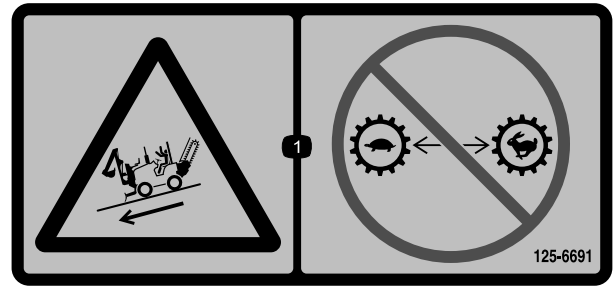

125-6691

1. Slope hazard—do not shift gears while the machine is on a slope.

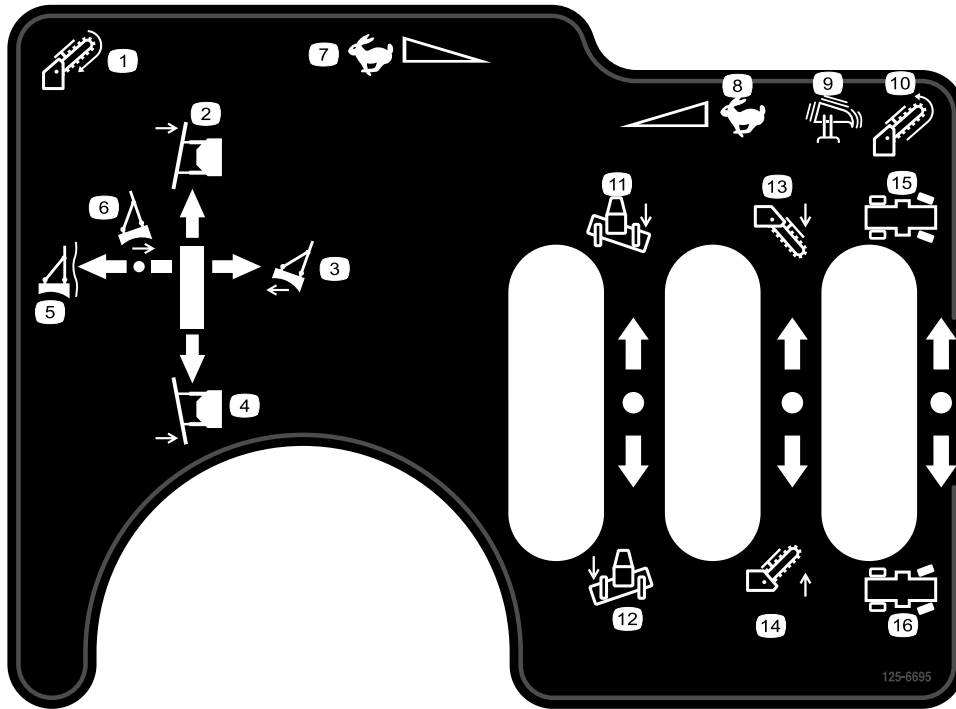

125-6695

1. Trencher chain—forward
2. Backfill blade—pivot left
3. Backfill blade—raise
4. Backfill blade—pivot right
5. Backfill blade—float
6. Backfill blade—lower
7. Fast forward
8. Fast reverse
9. Engage the vibratory plow
10. Trencher chain—reverse
11. Backfill blade—tilt right
12. Backfill blade—tilt left
13. Trencher—lower
14. Trencher—raise
15. Rear steering left
16. Rear steering right

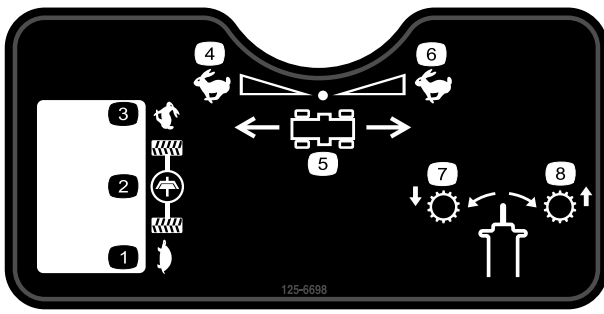

125-6698

- | | |
|-----------------|--------------------------------|
| 1. Slow | 5. Machine direction of motion |
| 2. Clutch | 6. Fast reverse |
| 3. Fast | 7. Shift (low range) |
| 4. Fast forward | 8. Shift (high range) |

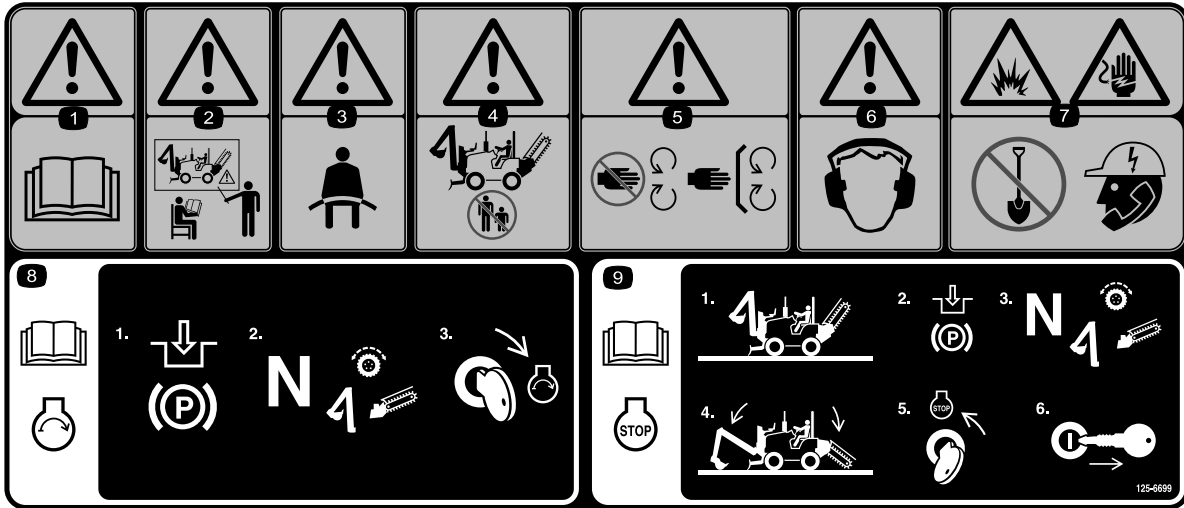

125-6699

- | | |
|--|--|
| 1. Warning—read the <i>Operator's Manual</i> . | 6. Warning—wear hearing protection. |
| 2. Warning—do not operate the machine unless you are trained. | 7. Explosion hazard; electric shock hazard—do not dig until you have called local utilities. |
| 3. Warning—always wear a seat belt when operating the machine. | 8. Read the <i>Operator's Manual</i> for information on starting the engine—1) Engage the parking brake; 2) Set the traction and attachments to the Neutral position; 3) Turn the key to the engine Start position. |
| 4. Warning—keep bystanders away from the machine. | 9. Read the <i>Operator's Manual</i> for information on stopping the engine—1) Park the machine on a level surface; 2) Engage the parking brake; 3) Set the traction and attachments the Neutral position; 4) Lower the attachments; 5) Turn the key to the engine Stop position; 6) Remove the key from the ignition. |
| 5. Warning—keep away from moving parts; keep all guards and safety devices in place. | |

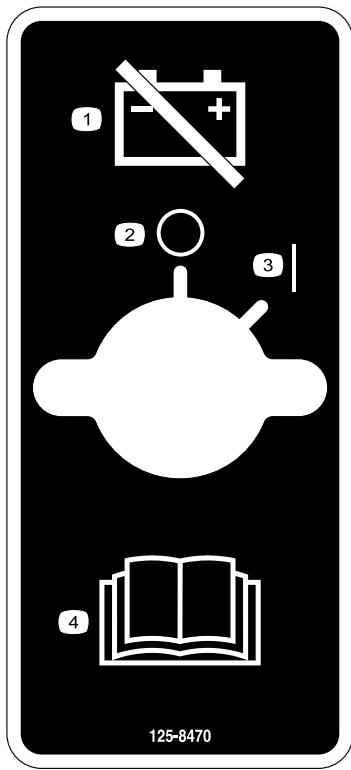

125-8470

1. Disconnect the battery.
2. Off
3. On
4. Warning—read the *Operator's Manual*.

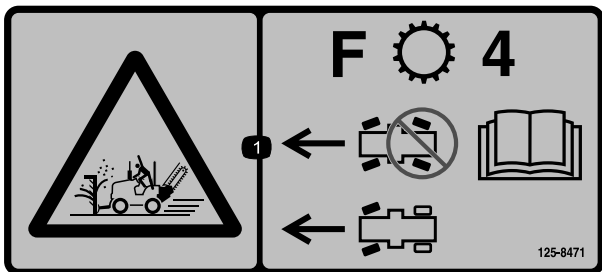

125-8471

1. Use front wheel steering only when moving the machine forward in 4th gear.



125-8472

1. Engine—stop
2. Engine—run
3. Engine—start



125-8473

1. Explosion hazard—wear eye protection.
2. Chemical burn hazard—flush affected area with water and seek medical help.
3. Fire hazard—keep open flames away.
4. Poison hazard—keep children away from the battery.

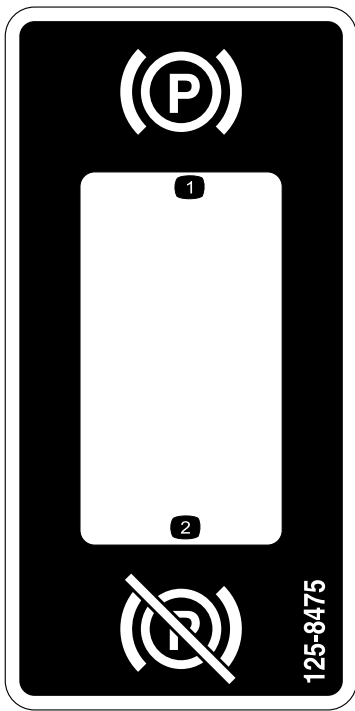

125-8475

1. Engage the parking brake.
2. Disengage the parking brake.

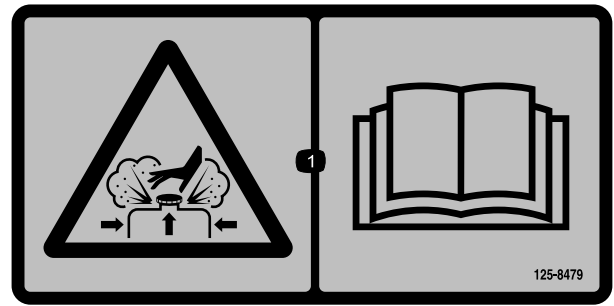

125-8479

1. Burn hazard from contents under pressure—read the *Operator's Manual*.



125-8480

1. Warning—do not climb on ROPS.



125-8478

1. Diesel fuel



125-8481

1. Hydraulic supply

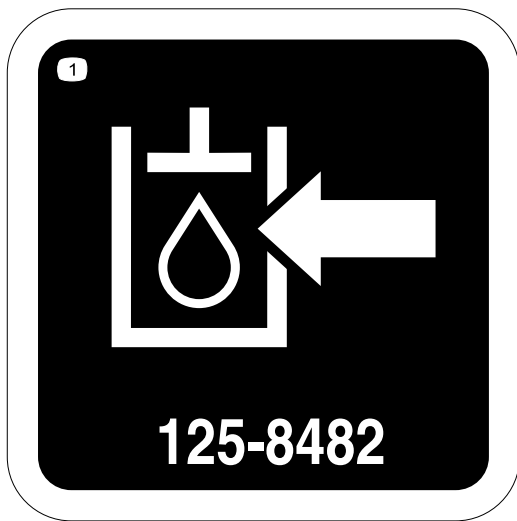

125-8482

1. Hydraulic return

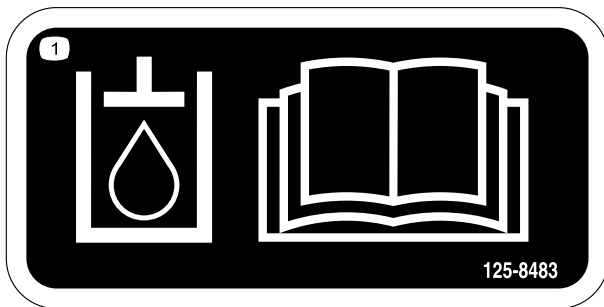

125-8483

1. Read the *Operator's Manual* for hydraulic oil information.

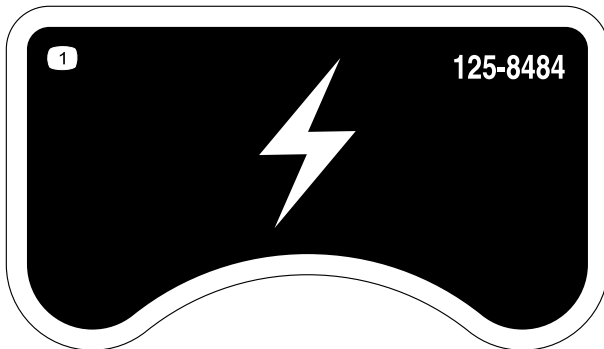

125-8484

1. 12-volt receptacle



Battery Symbols

Some or all of these symbols are on your battery.

- | | |
|--|---|
| 1. Explosion hazard | 6. Keep bystanders a safe distance from the battery. |
| 2. No fire, open flame, or smoking. | 7. Wear eye protection; explosive gases can cause blindness and other injuries. |
| 3. Caustic liquid/chemical burn hazard | 8. Battery acid can cause blindness or severe burns. |
| 4. Wear eye protection | 9. Flush eyes immediately with water and get medical help fast. |
| 5. Read the <i>Operator's Manual</i> . | 10. Contains lead; do not discard |

Product Overview

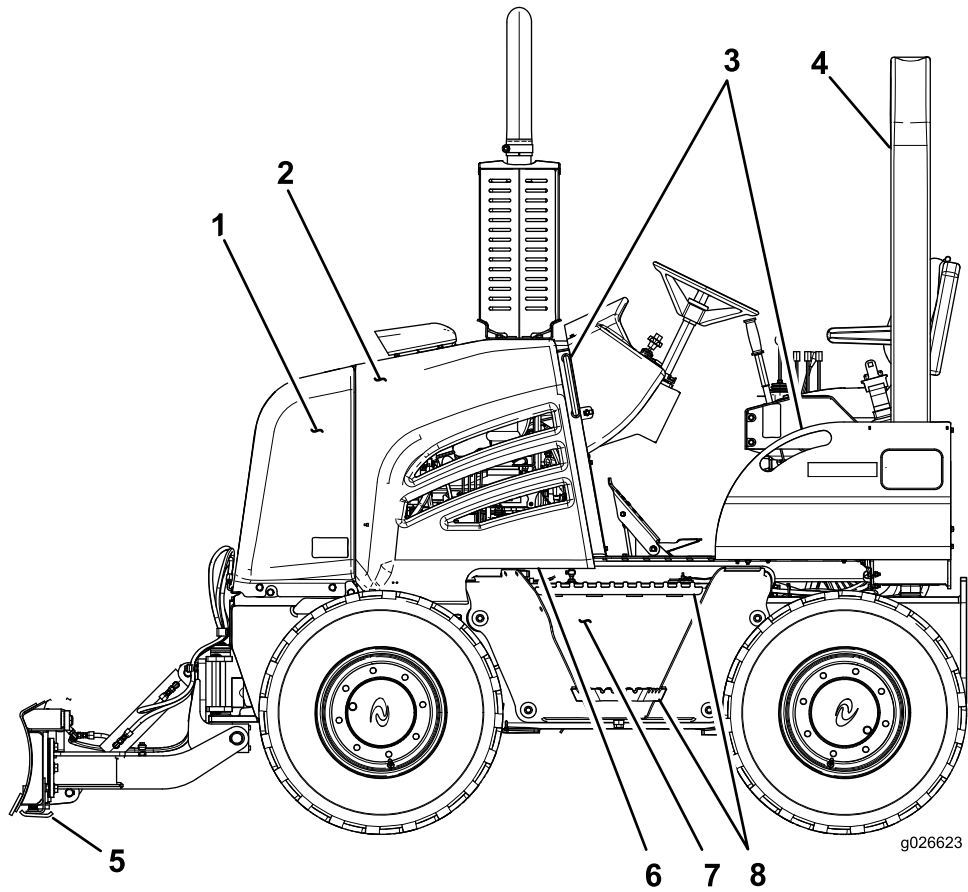

Figure 5
Left side of machine

- | | |
|--------------------|---------------------|
| 1. Nose panel | 5. Backfill blade |
| 2. Left side panel | 6. Operator walkway |
| 3. Grab handles | 7. Fuel reservoir |
| 4. ROPS enclosure | 8. Steps |

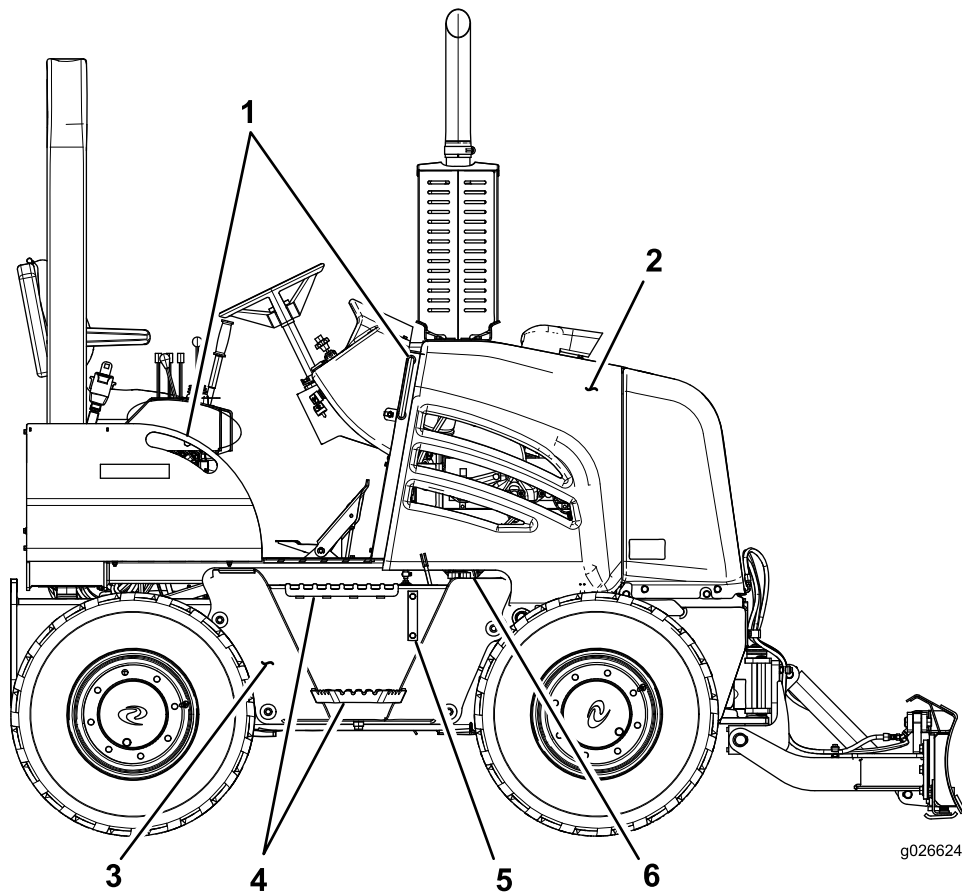

Figure 6
Right side of machine

- | | |
|-------------------------|--------------------------------|
| 1. Grab handles | 4. Steps |
| 2. Right side panel | 5. Hydraulic fluid sight gauge |
| 3. Hydraulic fluid tank | 6. Hydraulic-tank cap |

Controls

Become familiar with all the controls (Figure 7) before you start the engine and operate the machine.

Instrument Cluster

The warning and indicating lights (except the engine-intake preheat light) come on when you turn the key switch to the Run position before you start.

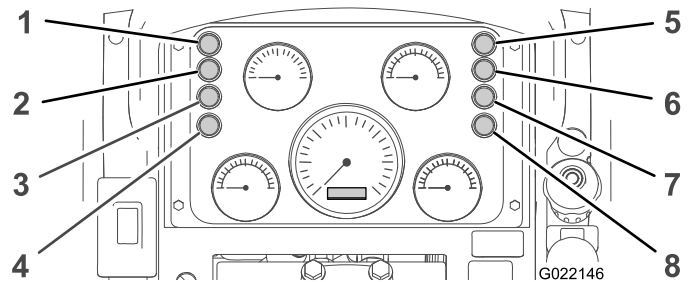

Figure 7
Instrument Cluster Lights

Warning Lights

The locations of these lights are shown in Figure 7.

- | | |
|---|----------------------------------|
| 1. Engine-intake preheat light | 5. Parking-brake set light |
| 2. Restricted hydraulic-pressure filter light | 6. Controls-in-neutral light |
| 3. Restricted air-cleaner light | 7. Low engine-oil pressure light |
| 4. Restricted hydraulic-return filter light | 8. Low hydraulic-pressure light |

- **Restricted hydraulic-pressure filter light**—This light turns on when the engine is running and the hydraulic-pressure filter is restricted. If the engine is running and this light turns on, stop the machine and replace the hydraulic-pressure filter.
- **Restricted air-cleaner light**—This light turns on when the engine is running and the air cleaner is restricted. If the engine is running and this light turns on, stop the engine and replace the air-cleaner element.
- **Restricted hydraulic-return filter light**—This light turns on when the engine is running and the hydraulic-return filter is restricted. If the engine is running and this light turns on, stop the machine and replace the hydraulic-return filter.
- **Low engine-oil pressure light**—This light turns on when the engine is running and the engine-oil pressure is below the normal operating range. If the engine is running and this light turns on, stop the engine and check the engine-oil level.
- **Low hydraulic-pressure light**—This light turns on when the engine is running and there is a loss of hydraulic pressure. If the engine is running and this light turns on, stop the engine, check the hydraulic fluid level, and check the hydraulic system for leaks.

Indicating Lights

The locations of these lights are shown in Figure 7.

- **Engine-intake preheat light**—This light turns on when you turn the key switch to the On position and the intake air is too cold to start the engine. When the intake air is warm enough for the engine to start, the light turns off, and you can then start the engine.
- **Parking-brake set light**—This light turns on when you turn the key to the On position and engage the parking brake.
- **Controls-in-neutral light**—This light turns on when you turn the key switch to the On position and the following controls are in the Neutral or the Stop position:
 - Traction control pedal
 - Utility-traction lever
 - Attachment control lever

Gauges

The locations of these gauges are shown in Figure 8.

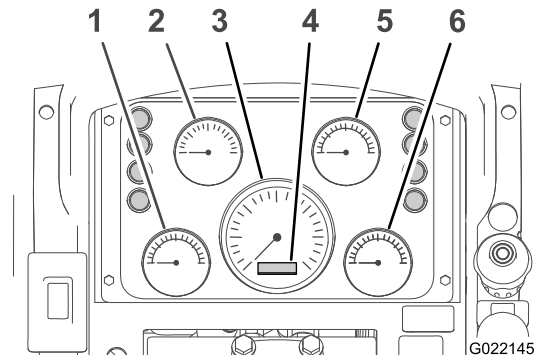

Figure 8

Instrument Cluster Gauges

- | | |
|-------------------------------------|--------------------------------------|
| 1. Engine-coolant temperature gauge | 4. Engine hourmeter |
| 2. Voltmeter | 5. Fuel-level gauge |
| 3. Engine tachometer | 6. Hydraulic-fluid temperature gauge |

- **Engine-coolant temperature gauge**—This gauge indicates the temperature of the coolant in the engine cooling system. The temperature ranges and the conditions that they indicate are as follows:

Note: If the needle of this gauge indicates that the coolant temperature is 116°C (241°F) or higher, stop the engine and allow it to cool. Then check the following: the coolant level, the radiator (for debris inside), the thermostat, and the condition of and tension on the drive belt.

 - 82°C (179°F) or lower: Low temperature
 - 82 to 115°C (180° to 240°F): Normal operating temperature
 - 116°C (241°F) or higher: High temperature
- **Voltmeter**—This gauge indicates the voltage of the battery or of the battery and the alternator. The voltage ranges of the voltmeter indicate the following conditions about the electrical system:
 - 11.4 volts or less: Low voltage for the battery
 - 11.5 to 12.5 volts: Normal voltage for the battery
 - 13.8 to 14.4 volts: Normal voltage for the battery and the alternator (with the machine running)
 - 14.5 volts or more: High voltage for the battery and the alternator (with the machine running)

Note: You must stop the engine before you check the charging system.
- **Engine tachometer**—This gauge indicates the engine speed in revolutions per minute (rpm). Each number on the gauge represents 1000 rpm, and each space equals 200 rpm.
- **Engine hourmeter**—This gauge indicates the total number of operating hours of the machine to a tenth of

an hour. Use the hourmeter to measure the operating hours between machine service intervals.

- **Fuel-level gauge**—This gauge indicates the amount of fuel in the fuel tank.
- **Hydraulic-fluid temperature**—This gauge indicates the temperature of the hydraulic fluid in the system.

Parking Brake Switch

Parking brake switch—Push the switch up to apply the parking brake (Figure 9); push the switch down to release the parking brake pedal.

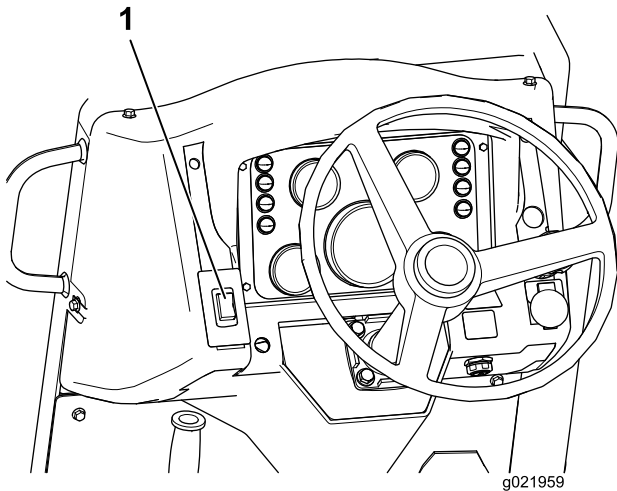

Figure 9

1. Parking brake switch

Note: The parking brake automatically engages when the engine stops.

Key Switch

The key switch (Figure 10) has the following 3 positions:

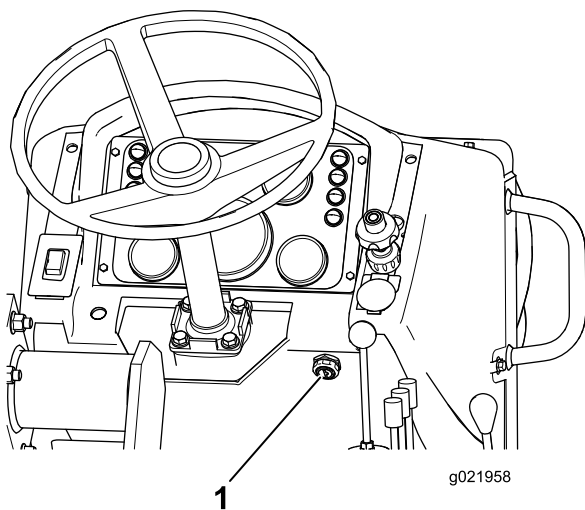

Figure 10

1. Key switch

- **Engine Stop**—Turn the key to this position to the stop the engine, de-energize the electrical system, and to remove the key.
- **Engine Run**—Turn the key to this position to energize the electrical system. The key returns to this position after you release the key from the Start position.
- **Engine Start**—Turn the key to this position to start the engine.

Throttle Knob

Use the throttle knob (Figure 11) to change the engine speed as follows:

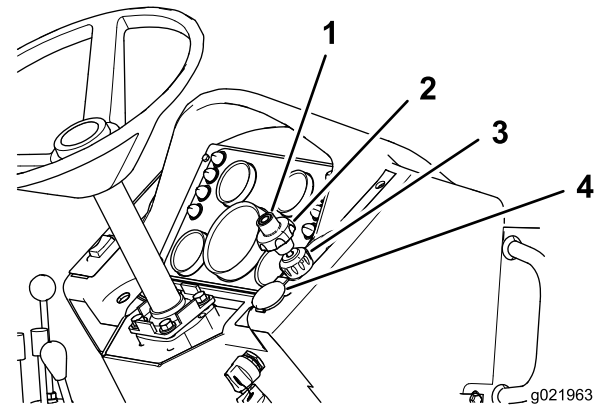

Figure 11

1. Throttle button
2. Throttle knob
3. Throttle lock
4. Electrical socket

- Push the button at the center of the knob while pulling the knob **up** to **increase** the engine speed.
- Push the button at the center of the knob while pushing the knob **down** to **decrease** the engine speed.
- Rotate the knob **counterclockwise** to make a **small increase** in the engine speed.
- Rotate the knob **clockwise** to make a **small decrease** in the engine speed.

Throttle Lock

Use the throttle lock (Figure 11) as follows to hold the throttle in position while you are operating the machine:

- Rotate the throttle lock clockwise to lock the throttle in position.
- Rotate the lock counterclockwise to release the throttle.
- Tighten the lock to prevent moisture from entering the cable and to prevent the cable from freezing in cold weather.

12-volt Electrical Socket

Use the 12-volt electrical socket (Figure 11) to power personal electronic equipment, such as a cell phone, a radio, or a GPS device.

Traction Controls

Important: The traction control pedal, the utility-traction lever, and the attachment control lever must be in the Neutral position before you can start the engine.

Important: You must sit in the operator seat to move the traction controls from the Neutral position and move the machine; otherwise, the engine will stop in 1 second.

Note: Operation of the traction control pedal overrides operation of the utility-traction lever.

Traction Control Pedal

The traction control pedal (Figure 12) controls the direction of travel and the speed of the machine.

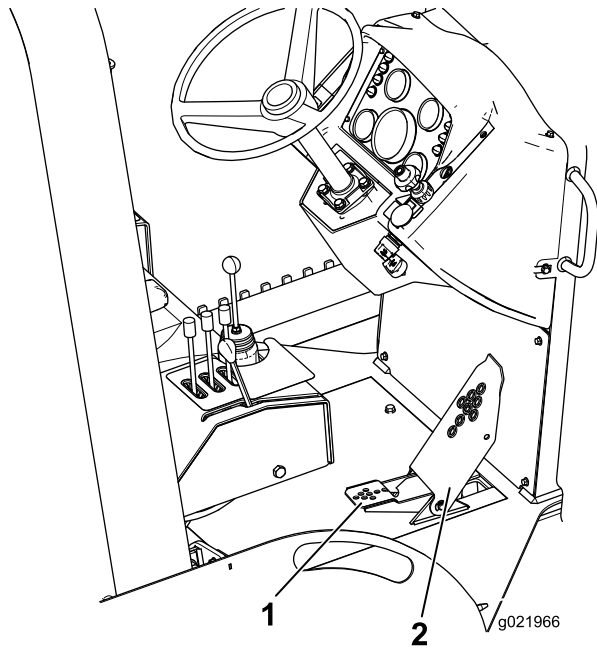

Figure 12

1. Heel pedal (reverse) 2. Toe pedal (forward)

To control the direction of travel and the speed of the machine, do the following:

- Push the **toe pedal** forward to move the machine **forward**.
- Push the **heel pedal** down to move the machine in **reverse**.
- For maximum speed, fully push the pedal.
- To reduce the speed of the machine or to stop the machine, move the pedal toward the Neutral position.

Utility-traction Lever

Note: The Neutral position for the utility-traction lever is detented. You must move the lever out of the detent to move the lever forward or rearward.

The utility-traction lever (Figure 13) has 3 positions: Forward, Neutral, and Reverse.

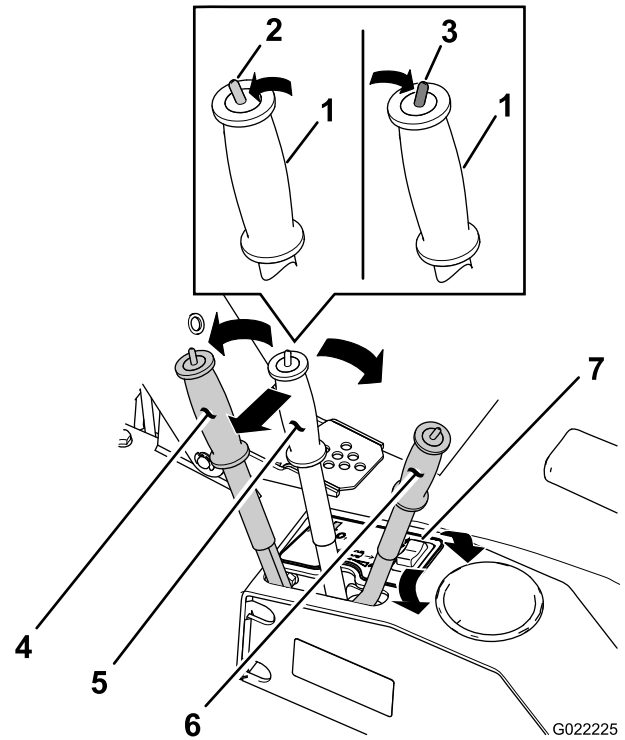

Figure 13

1. Handle 5. Utility-traction lever (neutral)
2. Drive mode switch (transport) 6. Utility-traction lever (reverse)
3. Drive mode switch (work) 7. Transmission range switch
4. Utility-traction lever (forward)

Use the utility-traction lever as follows:

- To move the machine forward, push the lever forward (away from you).
- To move the machine rearward, pull the lever rearward (toward you).

Note: The farther you push or pull the lever, the faster the machine moves.

Note: The lever locks into position when you release the lever.

Drive Mode Switch

The drive mode switch (Figure 13) controls the hydraulic pressure to the traction motor and has 2 positions: the transport mode and the work mode.

Important: Do not change from one drive mode to another while the machine is moving.

Note: The drive mode switch is used in conjunction with the transmission range switch.

To operate the drive mode switch, do the following:

- Pull the switch rearward (toward you) for **work** mode.
- Push the switch forward (away from you) for **transport** mode.

Transmission Range Switch

The transmission range switch (Figure 13) is used to control the gear reduction range of the transmission, and it has 2 positions (high and low).

Important: Do not shift between the transmission ranges while the machine is moving.

Note: The transmission range switch is used in conjunction with the drive mode switch.

To operate the transmission range switch, do the following:

- Press the switch to the right (near you) for low range.
- Press the switch to the left (away from you) for high range.

Attachment Control Panel

The attachment control panel is located on the right side of the operator seat (Figure 14).

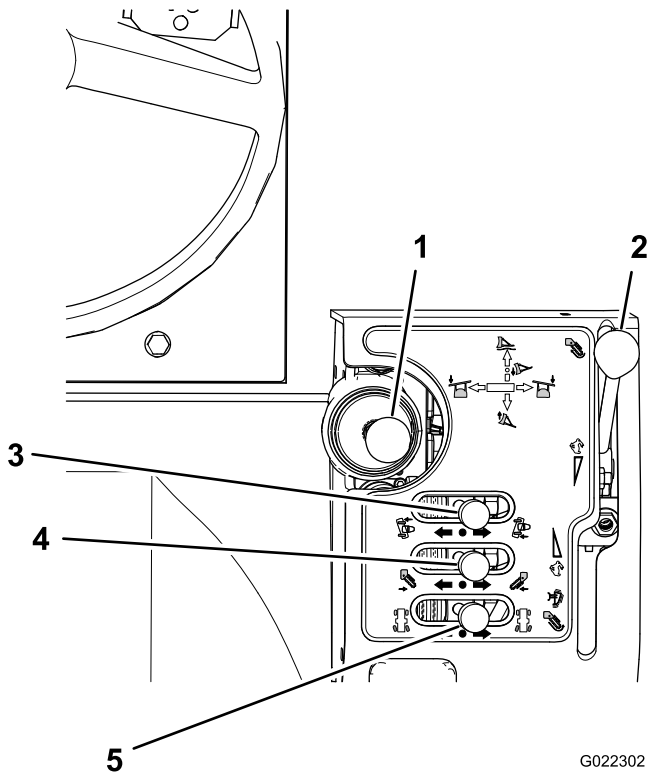

Figure 14

- | | |
|--|--------------------------------|
| 1. Backfill-blade joystick | 4. Attachment control |
| 2. Trencher chain direction/cable plow speed control | 5. Rear-wheel steering control |
| 3. Backfill tilt control | |

Backfill Blade Joystick

Use the backfill blade joystick (Figure 14) to float, raise, lower, and angle the backfill blade. Operate the joystick as follows:

- Push the joystick partially forward to lower the blade.
- Push the joystick all the way forward to float the blade.

- Pull the joystick back to raise the blade.
- Push the joystick to the right (away from you) to swing the blade to the right.
- Pull the joystick to the left (toward you) to swing the blade to the left.

Backfill Blade Tilt Lever

Use the backfill blade tilt lever (Figure 14) to tilt the blade. Operate the lever as follows:

- Push this lever to the right (away from you) to tilt the blade down on the right.
- Pull the control lever to the left (toward you) to tilt the blade down on the left.

Attachment Control Lever

Note: Use the attachment control lever (Figure 14) for the trencher.

Operate the control lever as follows:

- Push this lever to the right (away from you) to lower the attachment.
- Pull the lever to the left (toward you) to raise the attachment.

Note: When you release the lever, the machine maintains the attachment position.

Rear Wheel Steering Control Lever

Use the rear wheel steering control lever (Figure 14) to steer the rear wheels.

- Push the lever to the right (away from you) to turn the rear wheels to the right.
- Pull the lever to the left (toward you) to turn the rear wheels to the left.

Note: You can turn the front wheels by using the steering wheel only.

Rear Attachment Control Lever

The rear attachment control lever is located on the right side of the operator seat as shown in Figure 15.

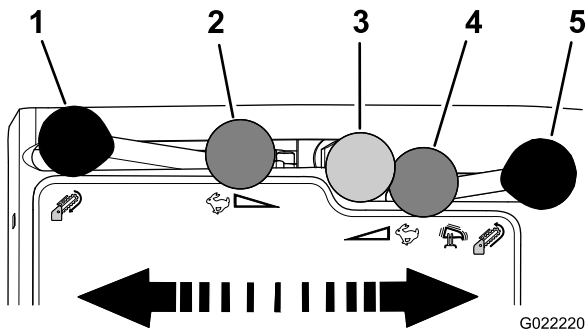

Figure 15

- | | |
|-----------------------------|--|
| 1. Fast forward chain speed | 4. Slow reverse chain speed or slow plow vibration |
| 2. Slow forward chain speed | 5. Fast reverse chain speed or fast plow vibration |
| 3. Neutral position | |

- **Cable plow operation (optional)**—move the control lever to control the cable plow as follows:
 - Move the control lever rearward to actuate the vibration of the blade; move the control lever fully rearward to increase the vibration.
 - Move the control lever to the Neutral position to decrease and stop the vibration.
- **Trencher operation**—move the control lever to control the trencher as follows:
 - Move the control lever forward to actuate the digging chain in the forward direction.
 - Move the control lever fully toward the front to increase the chain speed.
 - Move the control lever to the Neutral position to stop the chain.
 - Move the control lever rearward to reverse the digging chain direction.

Note: Moving the control lever forward beyond the Neutral position has no function.

Note: You must sit in the operator seat to move the attachment control lever from the Neutral position; otherwise, the engine will stop in 1 second.

Operator Seat and Seat Belt

Seat Interlock System

⚠ WARNING

The seat interlock system protects the operator from injury.

Do not disable the seat interlock system.

The seat interlock system requires the operator to sit in the operator seat while operating this machine.

Note: The neutral indicator light turns on when you turn the key switch to the On position and both the utility-traction control and attachment control levers are in the Neutral position.

Note: If the operator does not remain seated when the utility-traction lever is not in the Neutral position, the engine will stop in 1 second. **Do not** lay a heavy object on the seat or tamper with the seat interlock system in any way.

Forward and Rearward Seat Control

To move the operator seat (Figure 16) forward or rearward, pull the control bar to the left to adjust the seat forward or rearward.

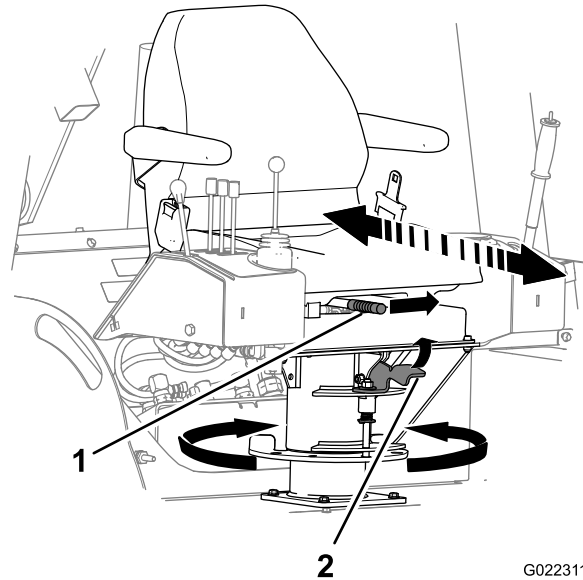

Figure 16

- | | |
|----------------|---------------|
| 1. Control bar | 2. Seat lever |
|----------------|---------------|

Seat Pivot Control

To rotate the seat, pull the seat lever up and rotate the seat to the desired position.

Seat Belt

▲ WARNING

Operating the machine without the rollover protection system (ROPS) securely in place can result in serious injury or death if the machine rolls over.

- Ensure that the roll bar is securely in place.
- Always wear a seat belt with the ROPS in place.
- Ensure that the operator seat is properly secured to the machine.

Note: Regulations in some localities require that seat belts on construction machines be 76 mm (3 inch) wide. Check with local authorities regarding the requirements for seat belts.

- To fasten the seat belt, insert the tab end into the left buckle.

Note: Ensure that the tab end and the buckle are securely fastened.

- To release the seat belt, push the button on the buckle.

Battery-disconnect Switch

The battery-disconnect switch is located behind the right engine cowl (Figure 17); use it to electrically disconnect the battery from the machine.

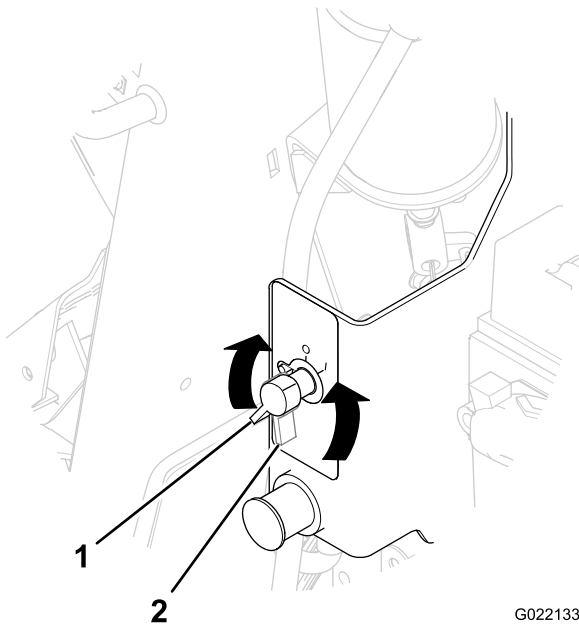

Figure 17

G022133

1. Battery On position
2. Battery Off position

- Rotate the battery disconnect clockwise to the On position.
- Rotate the battery disconnect counterclockwise to the Off position.

Specifications

Note: Specifications and design are subject to change without notice.

Basic Machine Dimensions and Weight Data

Wheel base	149.8 cm (59.0 in)
Overall height (to the top of the ROPS)	243.8 cm (96.0 in)
Overall width (at the tires)	170.2 cm (67.0 in)
Minimum ground clearance	30.5 cm (12.0 in)
Turning radius (2-wheel steering)	464.8 cm (183 in)
Turning radius (4-wheel steering)	294.6 cm (116 in)
Weight (without attachments)	2,494 kg (5,500 lb)

Attachments/Accessories

A selection of Toro approved attachments and accessories is available for use with the machine to enhance and expand its capabilities. Contact your Authorized Service Dealer or Distributor or go to www.Toro.com for a list of all approved attachments and accessories.

Operation

Note: Determine the left and right sides of the machine from the normal operating position.

Preparing for Work

Before operating the machine on the job site, review the following items:

- Gather all relevant information available about the job site before you begin working.
- Review all blueprints and other plans, and identify all existing or proposed structures, characteristics of the landscape, and other proposed jobs in the area scheduled at the same time as your job.

Note the following items at the job site:

- Changes in elevation in the proposed work area
- The condition and type of soil in the proposed work area
- Locations of structures, water, railroad tracks, and other obstructions that you will need to work near or around
- Utility markers, meters, and poles
- If the work site is near or on a roadway with traffic, call the local authorities regarding proper safety procedures and regulations.
- Access to the site
- Call your local One-Call service (811 in the US) or the One-Call referral number (888-258-0808 in the US and Canada) and ask the participating utility companies to locate and mark their underground utility lines. Also call utility providers that are not part of the One-Call system.

Adding Fuel to the Engine

Use ultra-low sulfur diesel (ULSD) fuel in the engine. Using other fuels can cause a loss of engine power and high fuel consumption.

Important: Do not use kerosene or gasoline instead of diesel fuel; otherwise, you will damage the engine.

Use only diesel fuel for the machine that meets Specification D975 of the American Society for Testing and Materials International. See your diesel fuel distributor.

Use only clean, fresh diesel fuel or biodiesel fuels with low (<500 ppm) or ultra low (<15 ppm) sulfur content. The minimum cetane rating should be 40. Purchase only enough fuel that you expect to use within 30 days to ensure that it stays fresh.

Fuel tank capacity: 75.7 L (20 US gal)

Use summer-grade diesel fuel (No. 2-D) at temperatures above 20°F (-7°C) and winter-grade diesel fuel (No. 1-D or No. 1-D/2-D blend) below 20°F (-7°C). Using winter-grade fuel at lower temperatures provides a lower flash point and

cold flow characteristics, which aid in starting the engine and help prevent clogging the fuel filter.

Using summer-grade fuel above 20° F (-7°C) contributes toward a longer fuel pump life and increased power compared to using winter-grade fuel.

⚠ WARNING

Fuel is harmful or fatal if swallowed. Long-term exposure to fuel vapors can cause serious injury and illness.

- **Avoid prolonged breathing of vapors.**
- **Keep your face away from nozzle and fuel tank or conditioner opening.**
- **Keep fuel away from your eyes and skin.**

⚠ DANGER

In certain conditions, fuel is extremely flammable and highly explosive. A fire or explosion from fuel can burn you and others and can damage property.

- **Fill the fuel tank outdoors in an open area when the engine is cold. Wipe up any fuel that spills.**
- **Never fill the fuel tank inside an enclosed trailer.**
- **Never smoke when handling fuel, and stay away from an open flame or where fuel fumes may be ignited by a spark.**
- **Store fuel in an approved container, and keep it out of the reach of children. Never buy more than a 30-day supply of fuel.**
- **Do not operate without entire exhaust system in place and in proper working condition.**

In certain conditions, fueling can release static electricity and cause a spark, which can ignite the fuel vapors. A fire or explosion from fuel can burn you and others and can damage property.

- Always place fuel containers on the ground, away from your vehicle before filling.
- Do not fill fuel containers inside a vehicle or on a truck or trailer bed, because interior carpets or plastic truck bed liners may insulate the container and slow the loss of any static charge.
- When practical, remove the equipment from the truck or trailer, and refuel the equipment with its wheels on the ground.
- If refuelling the equipment with its wheels on the ground is not possible, then refuel such equipment on a truck or trailer from a portable container rather than from a fuel dispenser nozzle.
- If you must use a fuel dispenser nozzle, keep the nozzle in contact with the rim of the fuel tank or container opening at all times until fueling is complete.

Using Biodiesel Fuel

This machine can also use a biodiesel blended fuel of up to B20 (20% biodiesel, 80% petrodiesel). The petrodiesel portion should be low or ultra-low sulfur. Observe the following precautions:

- The biodiesel portion of the fuel must meet specification ASTM D6751 or EN14214.
- The blended fuel composition should meet ASTM D975 or EN590.
- Biodiesel blends may be damage painted surfaces.
- Use B5 with a biodiesel content of 5% or less in cold weather.
- Check seals, hoses, gaskets that come in contact with the fuel, as they may degrade over time.
- The fuel filter may become plugged for a time after converting to a biodiesel fuel blend.
- Contact your distributor for more information about biodiesel fuel.

Storing Fuel

If you store fuel in a storage tank, it can accumulate foreign material or water. Keep the fuel storage tank outside, and keep the fuel as cool as possible. Remove water from the fuel in the storage container at regular intervals.

Filling the Fuel Tank

Note: Fill the fuel tank of the machine at the end of each day to prevent condensation in the fuel tank.

1. Clean around the fuel-tank cap (Figure 18), and remove the cap from the tank.

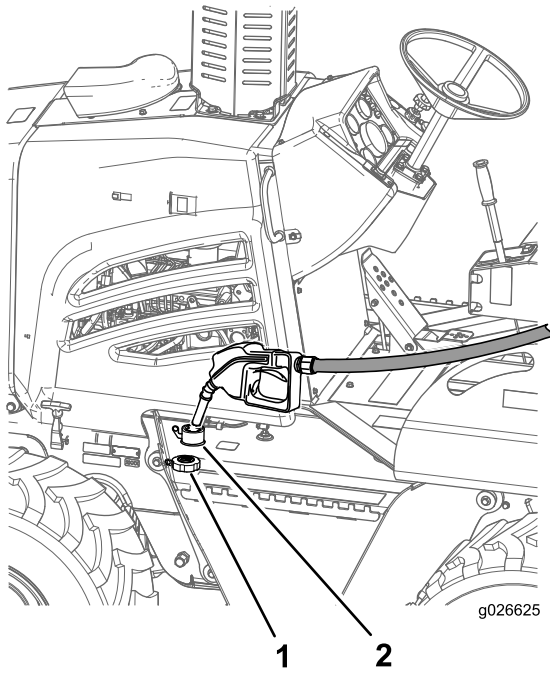

Figure 18

1. Fuel cap

2. Filler neck

Note: Remove the cap slowly to reduce the air pressure buildup.

2. Fill the fuel tank to the bottom of the neck to allow the fuel room to expand.

Note: The fuel tank capacity is 75.7 L (20 US gal).

3. Install the fuel tank cap and tighten it securely by hand.

Checking the Engine Oil Level

Service Interval: Before each use or daily

The engine is shipped with oil in the crankcase; however, check the oil level before and after you first start the engine.

Use only high-quality SAE 15W-40 heavy-duty engine oil with an API classification of CH-4 or higher.

While SAE 15W-40 oil with an API classification of CH-4 or higher is recommended for most climates, refer to Figure 19 for oil viscosity recommendations for extreme climates.

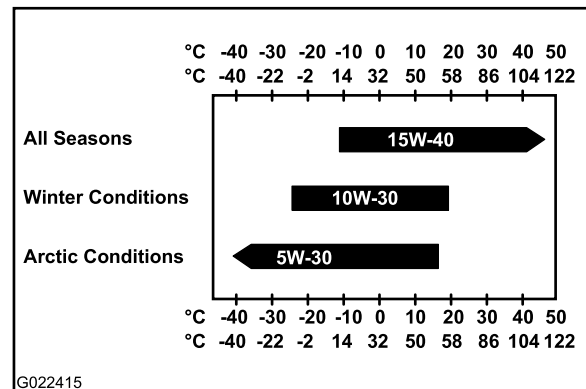

Figure 19

Note: Limited use of low-viscosity oils such as SAE 10W-30 with an API classification of CH-4 or higher can be used for easier starting and providing sufficient oil flow at ambient temperatures below -5°C (23°F). However, continuous use of low viscosity oil can decrease engine life because of wear.

Toro Premium Engine Oil is available from an Authorized Toro Service Dealer in either 15W-40 or 10W-30 viscosity with API classification CH-4 or higher. See the *Parts Catalog* for part numbers. Also, refer to the *Engine Operator's Manual*, included with the machine, for further recommendations.

Important: If the oil level in the crankcase is too low or too high and you run the engine, you may damage the engine.

1. Remove the right-side panel; refer to Removing the Side Panels (page 35).
2. Remove the dipstick (Figure 20) and wipe it clean with a clean cloth (Figure 20).

4. If the hydraulic fluid level is below the Add mark, remove the fill cap (Figure 21), add the specified hydraulic fluid to raise the fluid level up to the Full mark, and install the fill cap.

Inspecting the Machine Daily

Inspect the following items on the machine each day before you start the engine:

- Check for leaks under the machine, and repair all leaks.
- Check the tires for wear, damage, and low pressure.
- Check the machine for debris, especially around the engine.
Note: Ensure that the area near the engine is clean so that the engine cools properly.
- Clean or replace any safety or instructional decal that cannot be read.
- Clean machine components that you, the operator, use.
- Remove any loose items from the machine.
- Check the machine for broken, damaged, loose, or missing parts. Replace, tighten, or adjust these parts before you operate the machine.
- Repair or replace all damaged ROPS and seat belt parts.

Starting the Engine

⚠ WARNING

Before starting the engine, sit in the operator seat, fasten the seat belt, apply the parking brake, and ensure that the transmission direction control and digging control levers are in the Neutral position. Warn all persons around you that you are starting the engine.

Note: The seat interlock system prevents you from starting and operating the machine unless you are sitting in the operator seat. If you do not remain seated and the control levers are not in the Neutral position, the system will stop both the ground drive and the attachment drive in 1 second. Do not set a weighted object on the seat, bypass the seat interlock system, or tamper with the system.

1. Check the oil level; refer to Checking the Engine Oil Level (page 23).
2. Ensure that the battery-disconnect switch is in the On position.
3. Adjust the seat position and fasten the seat belt.
Note: Ensure that the seat is facing forward.
4. Set the parking brake switch to the On position.
5. Ensure that all control levers are in the Neutral or the Stop position and that the hand throttle is in the Idle position.

Note: The controls-in-neutral light will illuminate.

Note: If the machine is equipped with a backhoe, ensure that the engine shutoff control is pulled up.

6. Pull the throttle lever out to the 1/2 Throttle position.

Note: In extreme hot or cold weather, take the necessary precautions; refer to Operating the Machine in Extreme Conditions (page 26).

7. Turn the key switch to the On position, and check that the controls-in-neutral, the parking-brake warning, and the oil-pressure warning lights illuminate.

Note: The engine comes with an glow plug air system that sense the inlet air temperature. If the air temperature is cold, the wait-to-start warning light alerts the operator to wait for the intake air to warm up before starting. When the intake air is at the proper temperature for starting the engine, the warning light turns off.

8. Turn the key switch halfway between the On and Start positions, and check that the warning lights on the instrument cluster are working properly; refer to Instrument Cluster (page 15).

9. Turn the key switch to the Start position.

Note: If the engine starts and then stops, **do not** turn the key switch to the Start position again until the starter motor has stopped turning.

Important: *Do not operate the starter motor until it stops turning. Do not operate the starter motor for more than 30 seconds at one time. Allow the starter motor to cool for 30 seconds before you operate it again. When you engage the starter motor, you should see white or black smoke coming from the exhaust pipe; if you do not, check the fuel supply.*

10. When the engine starts, check the instruments to ensure that the gauge readings are correct. If any of the warning lights turn on, stop the engine and check the problem.
11. Run at the engine at 1000 rpm until the coolant is warm.
12. Cycle all the machine components before operating the machine, and check all the controls and components to ensure that they are working properly.

Note: If the engine is new or newly rebuilt, refer to Breaking in a New or Rebuilt Engine (page 26).

Setting the Engine Speed

Note: **Do not** run the engine at a low idle speed for long periods of time, because it causes a low operating temperature that can allow acids and deposits to form in the engine oil.

Note: For maximum life and machine performance, operate the engine at full throttle whenever the conditions allow you to safely do so.

- To **increase** the engine speed, push the throttle center button while **pulling out** the throttle (Figure 22).

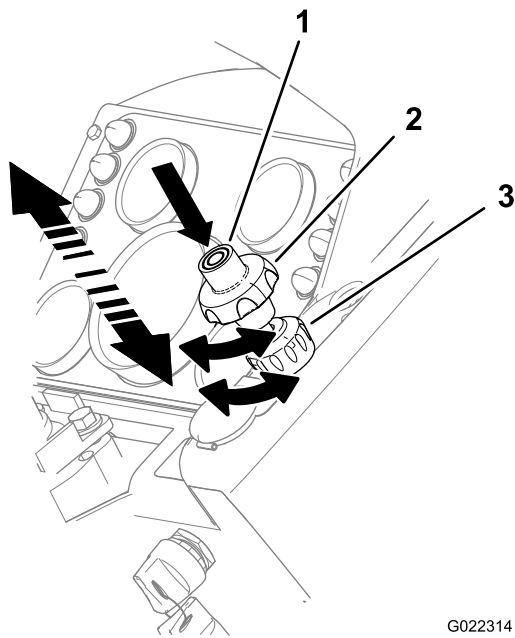

Figure 22

G022314

- | | |
|--------------------|------------------|
| 1. Throttle button | 3. Throttle lock |
| 2. Throttle knob | |

- To **decrease** the engine speed, push the throttle center button while **pushing in** the throttle.
- To **finely increase** the engine speed, rotate the throttle knob **counterclockwise**.
- To **finely decrease** the engine speed, rotate the throttle knob **clockwise**.

Stopping the Engine

- Park the machine on level ground, if possible.

Important: If you must temporarily park the machine on a slope or an incline, position the machine at a right angle to the slope, with the front of the machine toward the bottom of the hill. Ensure that the machine is behind an object that will not move.
- Support or lower all attachments to the ground.
- Set the parking brake.
- If the machine has been operating under a heavy load, decrease the engine speed to 1/4 throttle for 2 minutes to evenly cool the engine.
- Push the throttle lever to the Slow position, and turn the key switch to the Off position.
- If you leave the machine unattended, remove the key from the ignition switch.

Breaking in a New or Rebuilt Engine

During the first 20 hours of operation of a new or rebuilt engine, do the following:

- Keep the engine at a normal operating temperature.
- Do not run the engine at low idle speeds for long periods of time.
- Operate the machine with normal loads for the first 8 hours.
- Do not use special “break-in” lubricating oil. Use the specified oil; refer to Checking the Engine Oil Level (page 23) and Changing the Engine Oil Filter (page 39).

Operating the Machine in Extreme Conditions

Both hot and cold weather place unusual demands upon the machine and the attachments. You can minimize temperature-related problems on the machine by performing the following steps:

Hot Weather

- Clean all dirt and debris from the radiator, hydraulic oil cooler, and engine area to ensure that there is proper air flow to cool the engine.
- Wipe any debris from the air inlets in the hood side panels.
- Use lubricants that have the correct viscosity.
- Check the air cleaner dust valve more frequently in extremely dusty conditions.
- Check the condition of the fan drive belt. Replace it if it is cracked or worn.
- Operate the machine at an appropriate engine speed and transmission range for the operating conditions; do not overload the engine.
- Test the radiator cap before the hot weather begins; replace the cap if it is damaged.
- Maintain the correct coolant level in the reservoir and in the radiator, and ensure that there is a mixture of 50% ethylene glycol and 50% water in the cooling system.

Cold Weather

Operating your machine in cold weather requires special attention to prevent serious damage to the machine. Performing the following procedures will extend the service life of your machine:

- Clean the battery and ensure that it is fully charged.

Note: A fully charged battery at -17°C (0°F) has only 40% of the normal starting power. When the temperature decreases to -29°C (-20°F), the battery has only 18% of the normal power remaining.

- The machine comes with a maintenance-free battery. If you use a different battery and add water to it when the temperature is below 0°C (32°F), ensure that you charge the battery or run the engine for about 2 hours to prevent the battery from freezing.
- Inspect the battery cables and terminals. Clean the terminals, and apply a coat of grease on each terminal to prevent corrosion.
- Ensure that the fuel system is clean and free of water. Use the proper fuel for cold weather.

Note: Prevent wax and condensation from building up in the fuel tank by filling up the fuel tank at the end of each day.

- Check the coolant mixture before you operate the machine in cold weather. Use only a 50% ethylene glycol and 50% water mixture in the cooling system year round.
- Before operating the machine, move it at low speed and actuate each hydraulic control several times to warm the oil.

Important: The engine and the hydraulic system must be at operating temperature before you perform any work with it.

Note: Keep the digging chain free of mud and snow to prevent it from freezing after operation.

Operating the Parking Brake

- Push the parking brake switch (Figure 23) up to apply the parking brake.

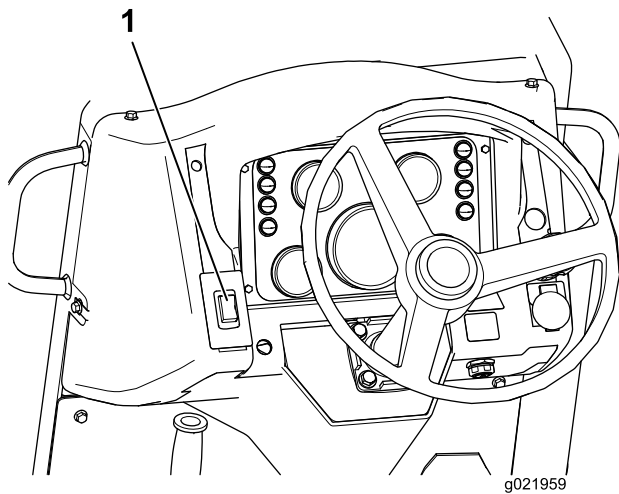

Figure 23

- Parking brake

- Push the parking switch down to release the parking brake.

Note: The parking brake automatically engages when you stop the engine.

Driving and Stopping the Machine

Using the Traction Control Pedal

The traction control pedal controls the direction of travel and the speed of the machine.

- To move the machine **forward**, push down on the **toe pedal**.
- To move the machine in **reverse**, push down on the **heel pedal**.

Note: To increase the speed, push down farther on the pedal; to decrease the speed, allow the pedal to move up toward the Neutral position.

Using the Utility-traction Lever

This control lever allows you to finely adjust the direction of travel and the speed of the machine during trenching, plowing, or boring.

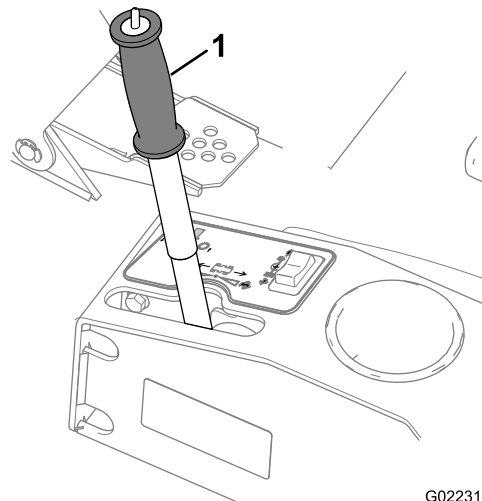

Figure 24

- Utility-traction lever

⚠ WARNING

To avoid injury, remain in the operator seat to operate the machine.

Note: If you do not remain in the operator seat, the engine will stop in 1 second.

- Release the parking brake.
- Move the lever out of the Neutral detent position and to one of the positions as follows:
 - Move the lever forward (toward the front of the machine) to move the machine forward.
 - Move the lever rearward (toward the rear of the machine) to move the machine in reverse.

Note: Move the lever completely forward or rearward for the maximum speed.

3. Release the lever.

Note: The lever is held in place front-to-rear by friction in order to maintain a constant speed.

4. Return the lever to the Neutral position to stop the machine.

Note: The ground drive foot control overrides the traction adjustment control lever. If you use the foot pedal, you must move the traction adjustment control lever to the Neutral position to release the override and return the lever to normal operation.

Stopping the Machine

▲ WARNING

Jumping on or off the machine can cause an injury.

When you get on or off the machine, always face the machine, use the hand rails and steps, move slowly.

This machine has hydrostatic braking. When you remove your foot from the ground drive foot pedal or move the utility-traction control back to Neutral, the machine stops. Always apply the parking brake after you stop the machine and before you stop the engine.

1. Move to level ground, if possible.

Important: If you must temporarily park the machine on a slope or an incline, position the machine at a right angle to the slope, with the front of the machine toward the bottom of the hill. Ensure that the machine is behind an object that will not move.

2. Support or lower all attachments to the ground.
3. Set the parking brake.
4. To stop the engine, refer to Stopping the Engine (page 26).
5. At the end of the workday, fill the fuel tank at the end of each work day to prevent condensation and moisture in the tank.

Operating the Transmission

Operating the Drive Mode Switch

This toggle switch (Figure 25) controls the mode for the hydraulic motor and has 2 positions: Transport and Work. Select the desired operating position. Push the switch to the rear (toward you) to set to Work speed (W), or push the switch forward (away from you) to set to Transport speed (T).

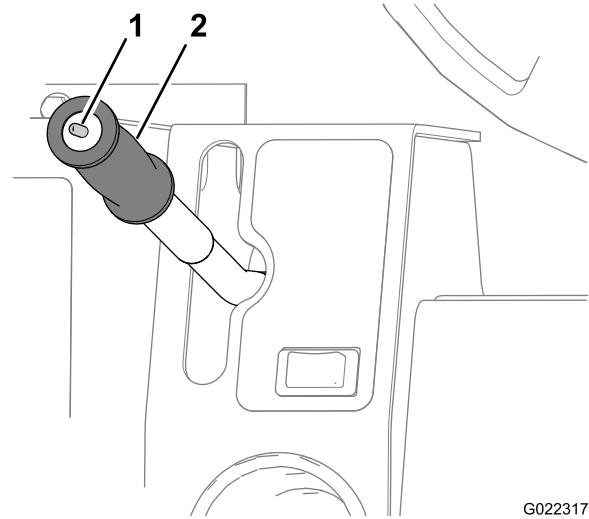

Figure 25

G022317

1. Drive mode switch
2. Utility-traction lever handle

Operating the Transmission Range Switch

This rocker switch (Figure 26) also has 2 positions: High and Low speed ranges. These ranges are used in conjunction with the ground speed control.

Press the switch to the right (toward you) for low range, or press the switch to the left (away from you) for high range. To shift the transmission, stop the machine (the traction control pedals and utility-control lever in the Neutral position) with the controls-in-neutral light illuminated.

Important: The transmission will not shift between ranges unless the machine has stopped moving.

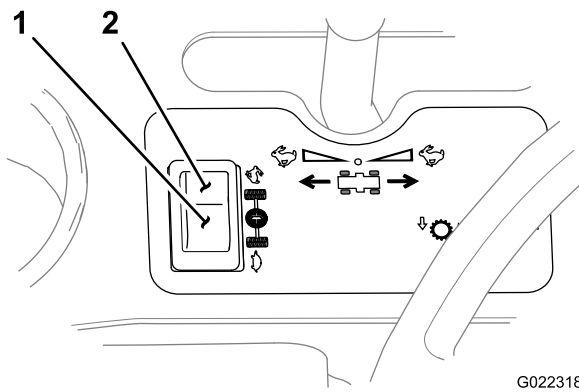

Figure 26

G022318

1. Low range
2. High range

The machine has a 2-mode hydrostatic drive with a 2-range transmission to provide 4 forward and reverse speeds. Select the gear combination most appropriate for the operation that you will perform.

⚠ WARNING

The machine can roll uncontrolled if the traction controls are in the Neutral position.

Stop the machine and set the parking brake before shifting the transmission control.

- **First gear:** With the drive mode switch in the Work position, press the transmission range switch to the right (near you) to select the transmission into Low range.
- **Second gear:** With the drive mode switch in the Work position, press the transmission range switch to the left (away from you) to select the transmission into High range.
- **Third gear:** With the drive mode switch in the Transport position, press the transmission range switch to the right (near you) to select the transmission into Low range.
- **Fourth gear:** With the drive mode switch in the Transport position, press the transmission range switch to the left (away from you) to select the transmission into High range.

Gear	Drive Mode	Transmission Range
1st	Work	Low
2nd	Work	High
3rd	Transport	Low
4th	Transport	High

Preparing to Operate the Machine

After starting the engine but before operating the machine at the work site, do the following:

- Ensure that the ROPS and the seat belt are properly installed and in good working order.
- Ensure that all instruments, the controls-in-neutral light, and the all warning lights are working properly.
- Ensure that all controls are working properly in a clear, open area.

Note: The controls-in-neutral light will turn on when the key switch is in the On position and the utility-traction lever is in the Neutral position.

1. Warm up the engine.
2. Pull the throttle out to the Full position.
3. Raise the equipment and any attachments (trencher, plow, etc.).
4. Release the parking brake.

Note: You must remain seated in the operator seat before you move the engine; otherwise, the engine will stop in 1 second.

Note: The utility-traction lever controls the speed of the machine. The farther that you move the lever from the Neutral position, the faster the machine moves.

Important: Control the speed of the machine travel with the utility-traction lever, not the throttle.

5. Check the indicator lights frequently.

Using the Backfill Blade

Important: Operate the controls only while sitting in the operator seat.

Use the backfill blade to return the spoils into the trench. You control the backfill blade with joystick and the backfill blade lever control as shown in Figure 27.

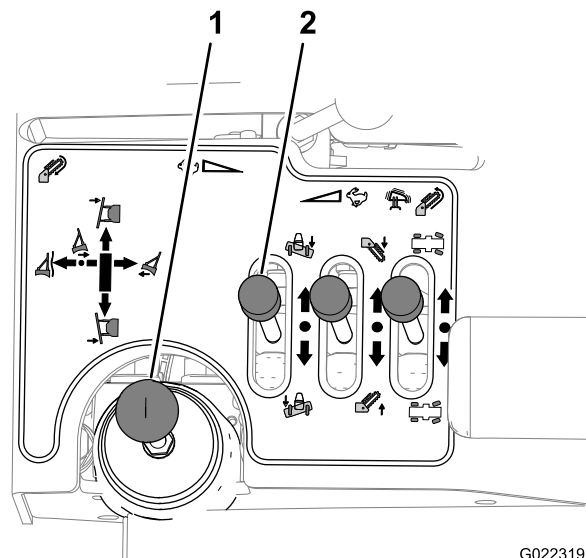

Figure 27

G022319

1. Joystick
2. Tilt lever

To operate the backfill blade, do the following:

- To raise the backfill blade: Move the joystick rearward.
- To lower the backfill blade: Move the joystick partially forward.
- To angle the backfill blade to the right: Move the joystick to the right.
- To angle the backfill blade to the left: Move the joystick to the left.
- To hold the backfill blade: Keep the joystick in the Hold (neutral) position.
- To float the backfill blade: Move the joystick fully forward.
- To tilt the backfill blade down on the right: Move the tilt lever right (away from you).
- To tilt the backfill blade down on the left: Move the tilt lever left (toward you).

Note: For best results when backfilling the spoils while parallel to the trench, make 2 or 3 passes over the spoil pile with the blade.

Note: If the spoil pile is large, operate the machine at a right angle to the trench.

Transporting the Machine

Be sure that you understand the safety rules and laws for the area in which you are using the machine. Ensure that both the truck and the machine are equipped with the proper safety equipment.

Loading the Machine onto a Trailer

1. Ensure that the trailer and the ramp can support both your weight and the weight of the machine.
2. Always have the attachments ready to transport when you are loading or unloading the machine.
3. Block the front and rear wheels of the trailer.
4. Slowly and carefully move the machine onto the trailer.
5. Lower the attachments to the trailer.
6. Engage the parking brake.
7. Stop the engine and remove the key.
8. Block the front and rear wheels of the machine.
9. Fasten the front of the machine to the trailer using straps and a binder (Figure 28).

Note: Use the front axle to secure the machine.

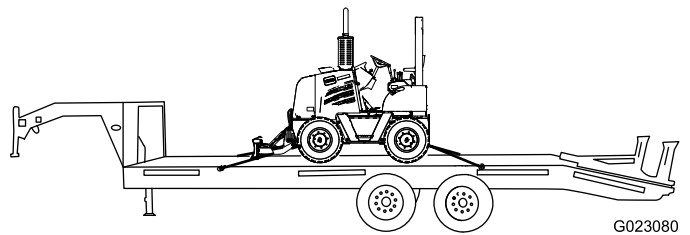

Figure 28

10. Fasten the rear of the machine to the trailer using chains and a binder (Figure 28).
Note: Use the rear axle to secure the rear of the machine.
11. Measure the distance from the ground to the highest point of the machine.
Note: You must know the clearance height of the machine.
12. Remove the blocks from the front and rear trailer wheels.
13. After you have driven a few miles, stop the truck and check your load.
Note: Ensure that the chains are still tight and that the machine has not moved on the trailer.

Unloading the Machine from a Trailer

1. Block the front and rear trailer wheels.
2. Remove the blocks from the front and rear wheels of the machine.
3. Remove the straps from the machine.
4. Start the engine.
5. Ensure that the attachments are in the Transport position.
6. Slowly move the machine off the trailer.

Lifting the Machine with a Spreader Bar

1. Attach a crane lift cable to the single-lift point of a spreader bar.
2. Attach 2 of the lift cables on one end of the spreader bar to a lifting bar placed under the rear of the machine frame.
3. Attach the remaining 2 spreader bar lift cables to a lifting bar placed under the front of the machine frame.
4. **Carefully** and **slowly** lift the machine, and lower it to the desired location.

Moving a Non-functioning Machine

Repair a non-functioning machine on the job site, if possible. Otherwise, you must determine whether you can move the machine without further damaging it.

If you must tow the machine, perform the following steps using caution:

Note: If you do not have a rigid drawbar, use 2 towing machines. Attach a tow chain each to the front and rear towing machines. Use the front towing machine to move the non-functioning machine and the rear towing machine to stop the non-functioning machine.

Note: This machine has hydrostatic braking. When you stop the engine, the brakes automatically engage.

1. Disconnect the hydraulic hose from the parking brake cylinder as shown in Figure 29.

Note: Plug the open end of the hose to prevent the hydraulic fluid from leaking out.

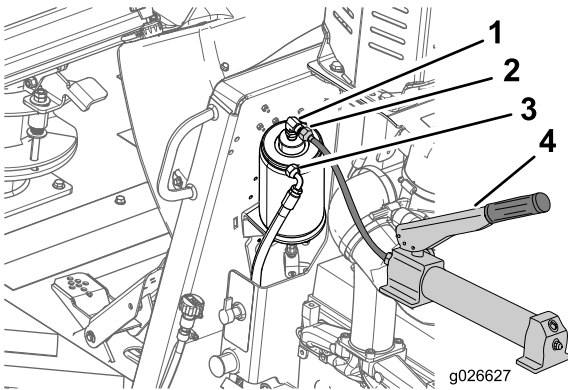

Figure 29

- | | |
|---|--|
| 1. Parking brake cylinder hydraulic fitting | 3. Hand pump fitting connected to the cylinder fitting |
| 2. Hydraulic brake hose | 4. Hand pump |

2. Connect a hydraulic-hand pump capable of producing 350 psi to the brake cylinder (Figure 29).
3. Operate the hand pump until the brakes are released.
4. Move the utility-traction lever to the Neutral position.

Note: You can move the machine up to 8 km/h (5 mph) and a distance up to 1.6 km (1 mile) away. To transport a disabled machine more than 1.6 km (1 mile), you must use a suitable trailer; refer to Transporting the Machine (page 30).

5. Tow the machine to the transport vehicle or to a site where you can repair the machine.
6. Disconnect the hand pump and connect the hose to the parking brake cylinder before transporting or making any repairs.

Completing the Work for the Day

When you complete your work for the day, do the following:

1. Backfill the spoils in the part(s) of the trench in which you are finished working.
2. Move the machine to a safe and stable location.
3. Move all levers to the Neutral position.
4. Engage the parking brake.
5. Lower all attachments to the ground.
6. Let the machine idle for a few moments to cool it down.
7. Shut off the engine, wait for all moving part to stop, and remove the ignition key.
8. Turn the battery disconnect switch to the Disconnect position.

Completing the Project

1. After you complete the project, return the spoils back into the trench with the backfill blade; refer to Using the Backfill Blade (page 29).
2. Return the spoils into the trench.
 - A. Move the machine to the end of the trench, a few feet (meters) away from the spoil pile.
 - B. Aim the machine at the outer edge of the pile.
 - C. Adjust the backfill blade to fit the slope of the ground.
 - D. Move the outer edge of the spoil pile toward the trench.
3. Spray the dirt and mud off the machine with water.

Note: Make at least 2 passes at the pile to move it.

- E. Repeat the steps above for the spoil pile on the other side of the trench.
 - F. Float the backfill blade over the length of the trench.
4. Transport the machine from the completed work site; refer to Transporting the Machine (page 30).

Maintenance

Recommended Maintenance Schedule(s)

Maintenance Service Interval	Maintenance Procedure
After the first 100 hours	<ul style="list-style-type: none"> • Check the oil level in the wheel hubs. • Check the oil level in the front and rear axles. • Check the oil level in the transmission.
After the first 200 hours	<ul style="list-style-type: none"> • Change the wheel hub oil. • Change the oil in the axles. • Change the oil in the transmission and rear axle.
Before each use or daily	<ul style="list-style-type: none"> • Check the engine oil level. • Check the hydraulic fluid level in the reservoir. • Grease the machine. • Check the engine oil level. • Check the restricted air-cleaner light for a restricted air cleaner. • Check the tires and wheels for damage. • Check the coolant level in the reservoir.
Every 50 hours	<ul style="list-style-type: none"> • Check and clean the dust valve. • Check the fuel-water separator for water and sediment. • Maintain the proper air pressure in the tires. • Check the coolant level in the radiator.
Every 200 hours	<ul style="list-style-type: none"> • Grease the front and rear axles.
Every 250 hours	<ul style="list-style-type: none"> • Change the engine oil. • Change the engine oil filter. • Check the oil level in the wheel hubs. • Check the oil level in the front and rear axles. • Check the oil level in the transmission. • Check the condition of the engine drive belt.
Every 300 hours	<ul style="list-style-type: none"> • Clean the axle breather for each axle. • Check the condition of the coolant system components. Clean dirt and debris from them and repair or replace the components as necessary.
Every 500 hours	<ul style="list-style-type: none"> • Grease the drive shaft. • Replace the secondary fuel filter. • Replace the primary fuel filter. • Change the hydraulic-pressure filter. • Change the hydraulic-return filter. • Check and maintain the ROPS; check it after an accident.
Every 1,000 hours	<ul style="list-style-type: none"> • Change the wheel hub oil. • Change the oil in the axles. • Change the oil in the transmission and rear axle. • Check the concentration of the coolant. • Check the tension on the engine drive belt. • Change the hydraulic fluid and clean the breather.
Every 2,000 hours	<ul style="list-style-type: none"> • Clean the cooling system.

Premaintenance Procedures

General Safety

⚠ WARNING

Improperly servicing or repairing the machine can cause injury or death.

If you do not understand the service procedures for this machine, contact an Authorized Toro Service Dealer or the service manual for this machine.

⚠ WARNING

Raised equipment on the machine without an operator can cause injury or death.

Before you leave the operating area, always support or lower the equipment to the ground and stop the engine.

⚠ WARNING

Replace all covers and guards after you service or clean the machine. Never operate the machine without the covers or guards in place.

1. Park the machine on a level surface.
2. Lower all attachments and stop the engine, and remove the key.
3. Allow the engine to cool 2 or 3 minutes.
4. Remove the right-side panel; refer to Removing the Side Panels (page 35).
5. Rotate the battery-disconnect switch to the Off position.

Lubrication

Greasing the Machine

Grease Type: Lithium-based grease.

Greasing the Front and Rear Axles

Service Interval: Every 200 hours

1. Clean the grease fittings with a rag.
2. Connect the grease gun to the grease fittings for the upper and lower pivots; apply 2 or 3 pumps of grease to each fitting (Figure 30 and Figure 31).

Note: There are 2 grease fittings at the axle pivot for each tire.

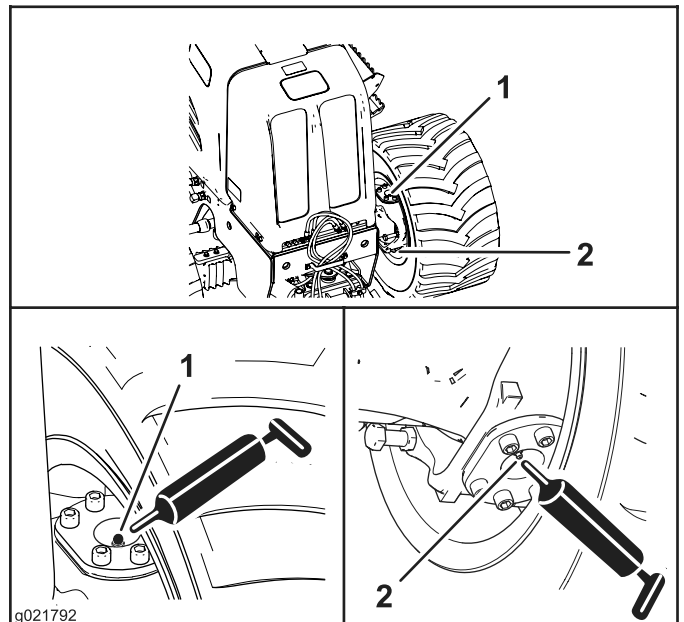

Figure 30
Front axle

1. Grease fitting (upper pivot)
2. Grease fitting (lower pivot)

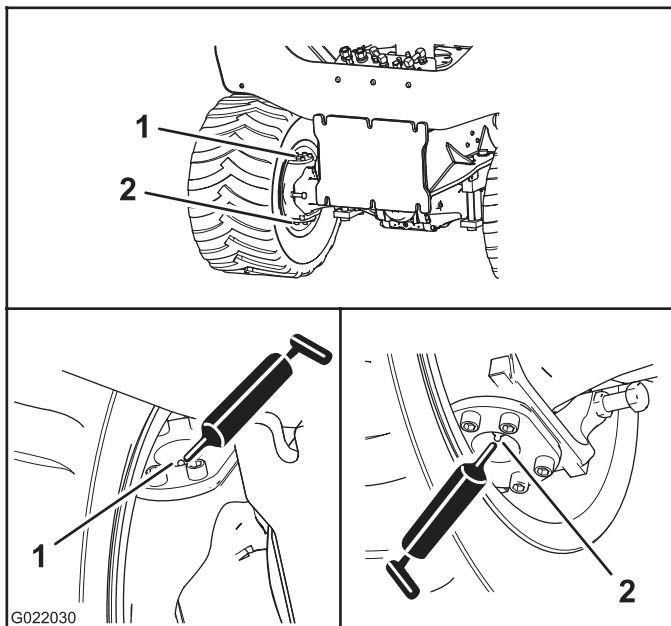

Figure 31
Rear axle

1. Grease fitting (upper pivot) 2. Grease fitting (lower pivot)
3. Wipe up any excess grease.

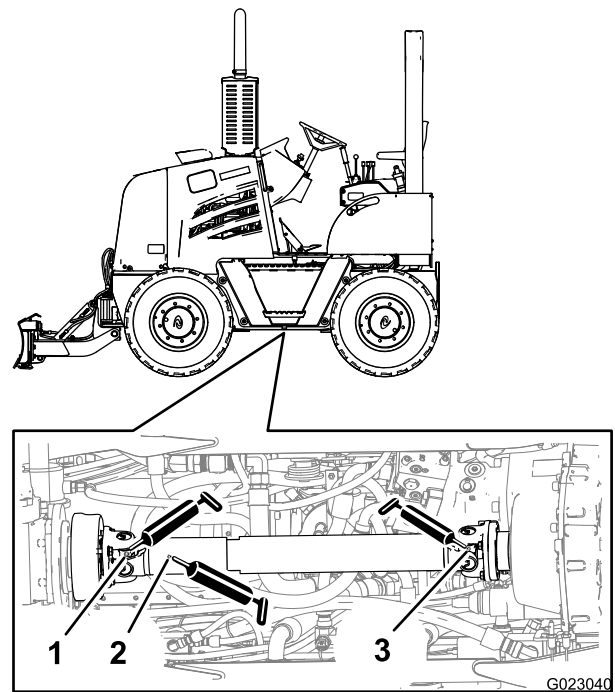

Figure 32

1. Grease fitting (forward universal joint) 3. Grease fitting (back universal joint)
2. Grease fitting (sliding joint)
3. Connect the grease gun to the grease fitting for the universal joint at the forward end of the drive shaft, and apply 2 or 3 pumps of grease to the fitting.
4. Connect the grease gun to the grease fitting for the universal joint at the back end of the drive shaft, and apply 2 or 3 pumps of grease to the fitting.
5. Wipe up any excess grease.

Greasing the Driveshaft

Service Interval: Every 500 hours

1. Clean the grease fittings with a rag.
2. Connect the grease gun to the grease fitting for the slide coupling at the at the forward end of the drive shaft, and apply 2 or 3 pumps of grease to the fitting (Figure 32).

Greasing the Backfill Blade

Service Interval: Before each use or daily

1. Clean the grease fittings with a rag.
2. Connect the grease gun to the upper and lower grease fittings for the lift cylinder, and apply 3 pumps of grease to each fitting (Figure 33).

Engine Maintenance

Before maintaining the engine, perform the following steps:

1. Park the machine on level ground, lower all attachments, and stop the engine.
2. Remove the ignition key and allow the engine to cool for 2 or 3 minutes.

Accessing the Engine

Removing the Side Panels

1. If the optional backhoe is installed, perform the following substeps to remove the left side panel; otherwise, skip to step 2:
 - A. At the left side of the machine, remove the retaining pin from the front end of the walkway (Figure 34).

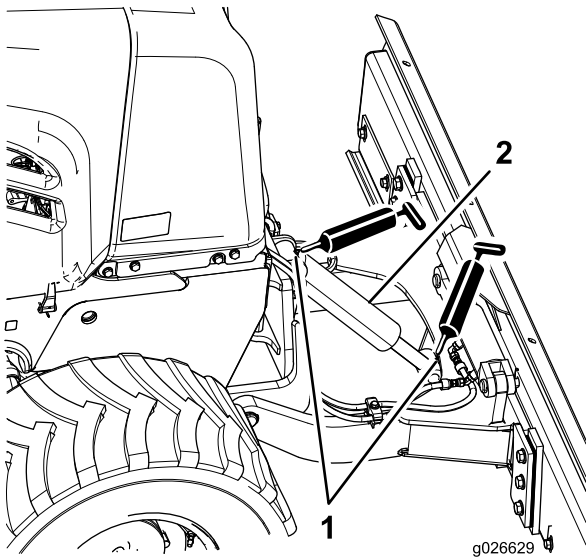

Figure 33

1. Grease fittings
 2. Lift cylinder
-
3. Wipe up any excess grease.

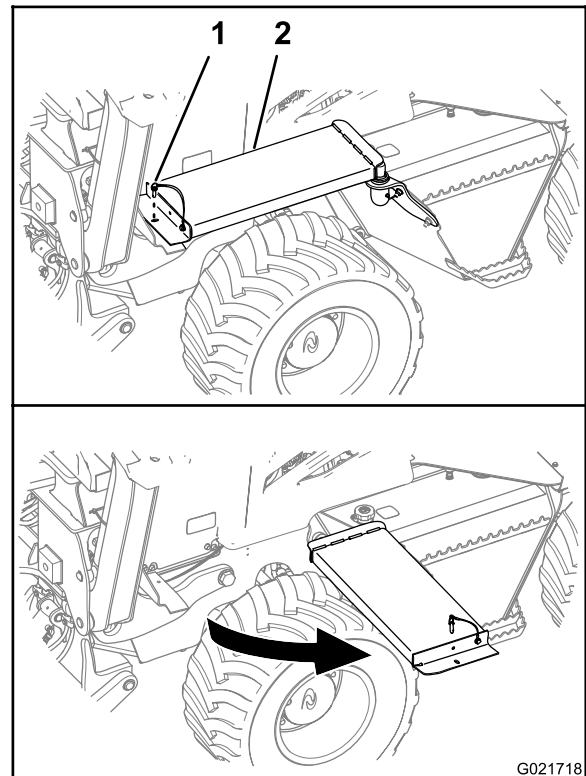

Figure 34

1. Retaining pin
2. Walkway

- B. Pivot the walkway away from the machine as shown in Figure 34.
2. Pull up on the hand grip of the panel latch, and swing the latch free from the anchor bracket (Figure 35).

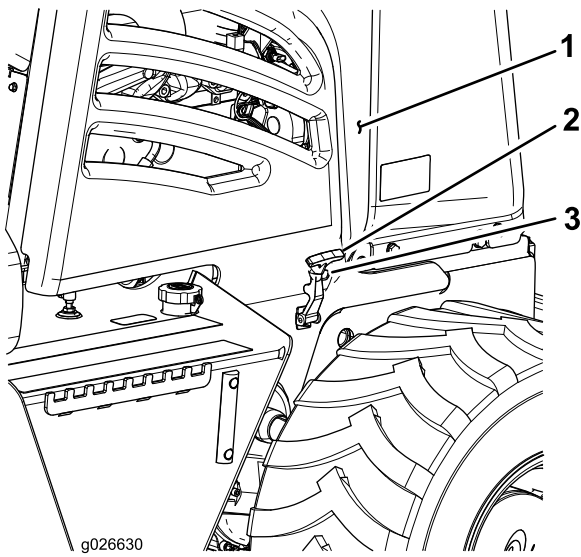

Figure 35

- 1. Side panel
- 2. Panel latch
- 3. Anchor bracket

3. Lift the side panel straight up and remove it from the machine (Figure 35).

Installing the Side Panels

1. Align the left side panel with the left side of the machine and the right side panel with the right side of the machine.
2. Align the tabs at the top of the side panel with the receiver brackets on the machine (Figure 36).

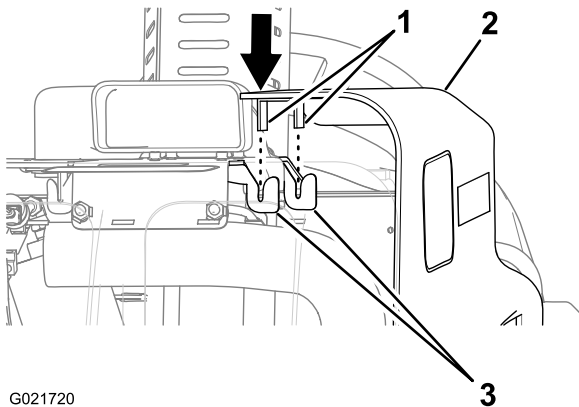

Figure 36

- 1. Tab
- 2. Side panel
- 3. Receiver brackets

3. Lower the side panel straight down.

Note: Ensure that the tabs of the side panel align into the receiver brackets on the machine.

4. Pull the hand grip of the panel latch outward, then pivot it up until it aligns in the anchor bracket (Figure 35).
5. Release the latch handle.

6. If the backhoe is installed on the machine, do the following substeps:
 - A. Rotate the front end of the walkway to its original position (Figure 34).
 - B. Align the hole in the walkway with the hole in the walkway support bracket (Figure 34).
 - C. Install the retaining pin through the holes.

Removing the Nose Panel

1. Remove both the left side panel and the right side panel from the machine; refer to Removing the Side Panels (page 35).
2. If the backhoe is installed on the machine, do the following substeps; otherwise, skip to step 3.
 - A. Remove the hairpin from the seat lock pin (Figure 37).

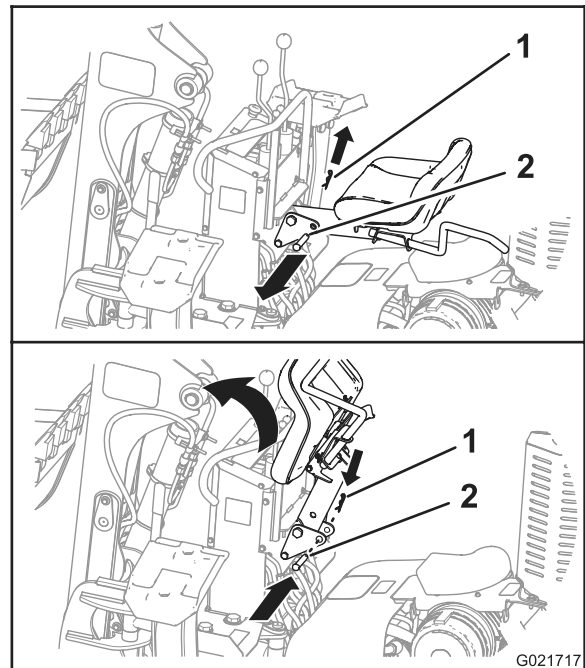

Figure 37

- 1. Hairpin
- 2. Seat lock pin

- B. Remove the seat lock pin from the frame of the backhoe and the seat post (Figure 37).
- C. Pivot the seat post upward, and insert the seat-lock pin through the holes in the frame of the backhoe to hold the seat up to make room for removing the nose panel (Figure 37).

Note: Install the seat lock pin and hairpin in the backhoe frame to hold the seat up position.

3. Remove the 4 bolts at the bottom of the left and right sides of the nose panel (Figure 38).

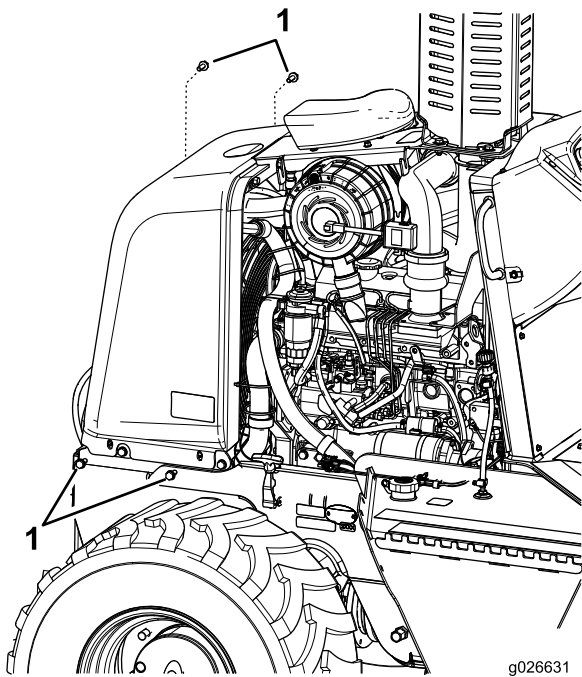

Figure 38

1. Bolts

4. Lift the nose panel up and off the machine (Figure 39).

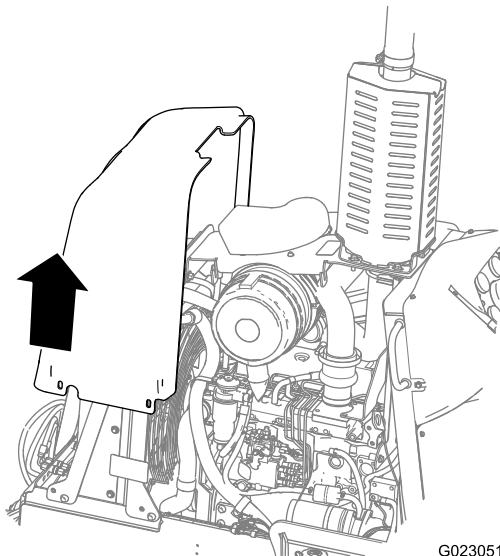

Figure 39

Note: When you remove the nose panel from the machine when the optional backhoe is attached, gently push the hoses in the front of the nose panel forward while lifting the nose panel upward.

Installing the Nose Panel

1. Align the nose panel over the radiator of the machine.
2. Lower the nose panel down and onto the machine (Figure 39).

Note: When you install the nose panel from the machine when the optional backhoe is attached, gently push the hoses in the front of the nose panel forward while lowering the panel into place.

3. Secure the nose panel to the machine with the 4 bolts that you removed during step 3 of Installing the Nose Panel (page 37).
4. If the backhoe is installed on the machine, do the following substeps:
 - A. Remove the seat lock pin and lower the seat post to the operating position (Figure 37).
 - B. Install the seat lock pin through the holes in the frame of the backhoe and the seat post (Figure 37).
 - C. Install the hairpin into the hole in the seat lock pin (Figure 37).
5. Install the left and right side panels on the machine; refer to Installing the Side Panels (page 36).

Servicing the Engine Oil and Filter

The engine is shipped with oil in the crankcase; however, check the oil level before and after you first start the engine.

The crankcase capacity is 11.0 L (11.6 US qt) with the filter.

Use only high-quality SAE 15W-40 heavy-duty engine oil with an API classification of CH-4 or higher.

While SAE 15W-40 oil with an API classification of CH-4 or higher is recommended for most climates, refer to Figure 40 for oil viscosity recommendations for extreme climates.

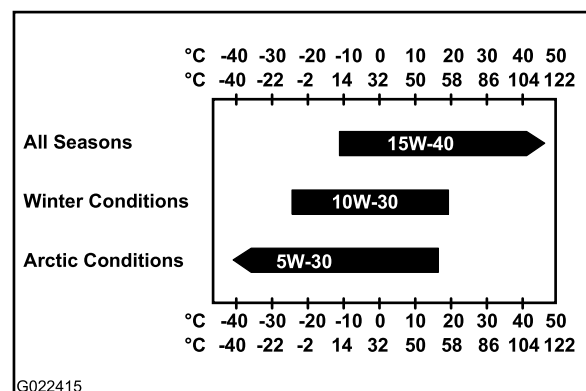

Figure 40

Note: Limited use of low-viscosity oils such as SAE 10W-30 with an API classification of CH-4 or higher can be used for easier starting and providing sufficient oil flow at ambient temperatures below -5°C (23°F). However, continuous use of low viscosity oil can decrease engine life because of wear.

Toro Premium Engine Oil is available from an Authorized Toro Service Dealer in either 15W-40 or 10W-30 viscosity with API classification CH-4 or higher. See the *Parts Catalog*

for part numbers. Also, refer to the *Engine Operator's Manual*, included with the machine, for further recommendations.

Checking the Engine Oil Level

Service Interval: Before each use or daily

Note: The best time to check the engine oil is when the engine is cool before it has been started for the day, if possible. If the oil level is at or below the Add mark on the dipstick, add oil to the engine to bring the oil level up to the Full mark. **Do not overfill.** If the oil level is between the Full and Add marks on the dipstick, you do not need to add oil.

1. Ensure that the machine is on a level surface.
2. Lower all attachments, set the parking brake, stop the engine, and remove the key.

Note: If you have run the engine, allow at least 10 minutes for the engine oil to settle in the crankcase.

3. Remove the right side panel; refer to Removing the Side Panels (page 35).
4. Remove the dipstick and wipe clean it with a clean cloth (Figure 41).

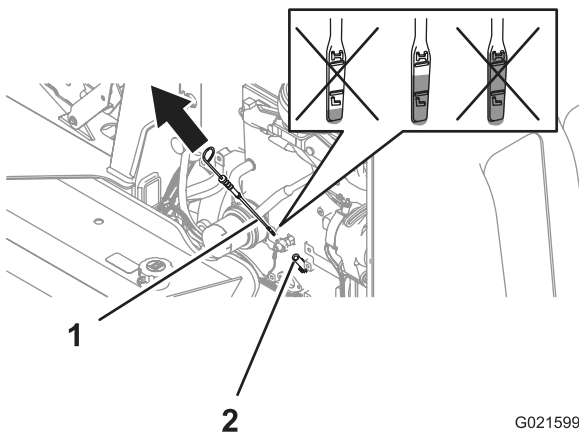

Figure 41

G021599

1. Dipstick
2. Dipstick tube

5. Insert the dipstick into the dipstick tube, pull the dipstick out again, and read the oil level on the dipstick (Figure 41).

Note: The oil level on the dipstick should be between the H (high) mark and L (low) mark.

6. If the oil level is below the L (low) mark, remove the fill cap and add oil until the level reaches the H (high) mark.

Important: Do not overfill the engine with oil.

7. Install the dipstick.
8. Install the right side panel; refer to Installing the Side Panels (page 36).

Changing the Engine Oil

Service Interval: Every 250 hours

Draining the Engine Oil

1. Run the engine a few minutes before changing the oil to warm it.

Note: Warm oil flows better and carries more contaminants.

2. Remove the right side panel; refer to Removing the Side Panels (page 35).
3. Place a drain pan that has a minimum capacity of 8.4 L (8.9 US qt) under the engine-oil drain fitting (Figure 42).

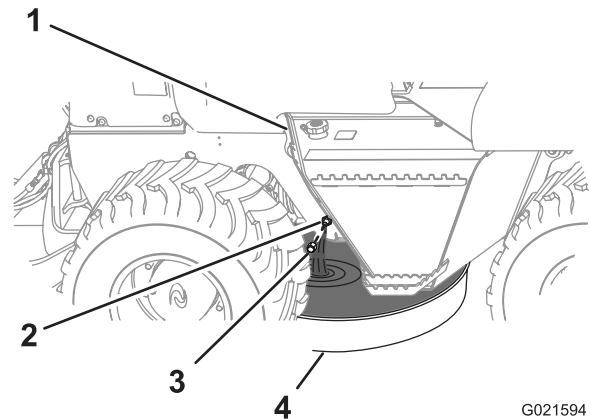

Figure 42

G021594

1. Engine-oil tank
2. Drain fitting
3. Cap
4. Drain pan

4. Remove the cap from the drain fitting and allow the engine oil to drain completely (Figure 42).

Note: Removing the oil-fill cap from the filler neck helps to drain the engine oil (Figure 43).

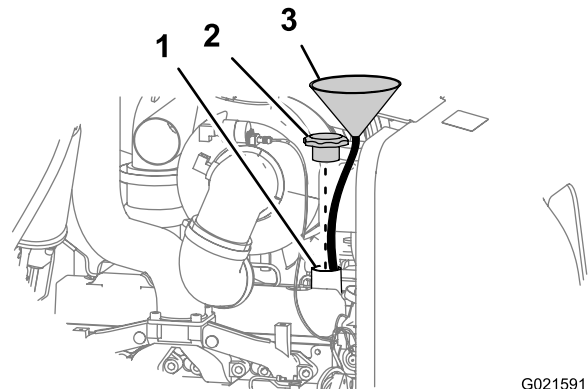

Figure 43

G021591

1. Filler neck
2. Oil-fill cap
3. Funnel

5. Clean the mating surfaces of the cap and the drain fitting.

6. Install the cap onto the drain fitting (Figure 42).

Filling the Engine with Oil

1. Remove the oil-fill cap from the filler neck by pulling the cap upward (Figure 42).

Note: Use a funnel with a flexible hose to direct the engine oil into the engine.
2. Fill the crankcase with approximately 7.0 L (7.4 US qt) of the specified engine oil; refer to Servicing the Engine Oil and Filter (page 37).
3. Install the oil-fill cap.
4. Start the engine, run it at idle for about 2 minutes, and check for oil leaks.
5. Stop the engine and remove the key.
6. Wait for 2 or 3 minutes and check the oil level; refer to steps 2 through 6 in Checking the Engine Oil Level (page 23).
7. Install the side panel; refer to Installing the Side Panels (page 36).

Changing the Engine Oil Filter

Service Interval: Every 250 hours

1. Remove the right side panel; refer to Removing the Side Panels (page 35).
2. Place a small drain pan under the oil filter and the oil-filter adapter (Figure 44).

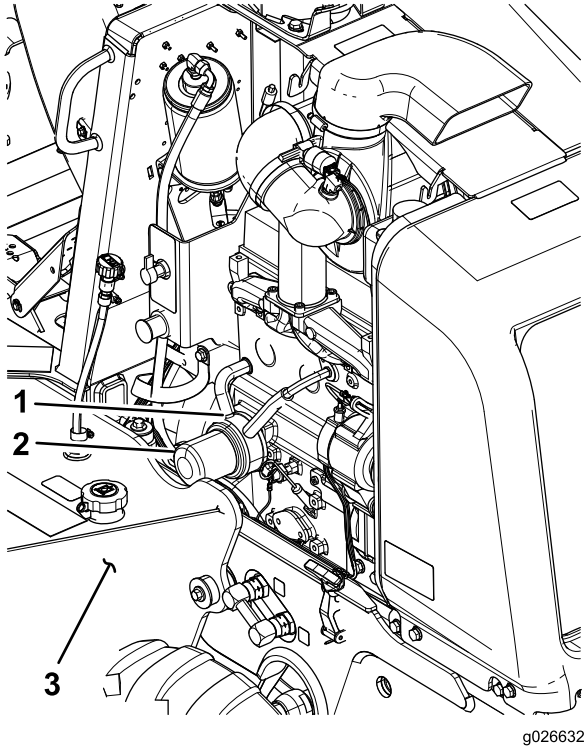

Figure 44

- | | |
|---------------|-------------------------|
| 1. Oil cooler | 3. Hydraulic-fluid tank |
| 2. Oil filter | |

3. Rotate the oil filter counterclockwise and remove the oil filter (Figure 44).

Note: Recycle the used oil filter according to local codes.

4. Use a clean rag to wipe clean the surface of the oil cooler, where the oil filter seats.
5. Fill the new oil filter with the specified engine oil, allow the filter element to saturate with the oil, and then pour out the excess oil.
6. Apply a thin layer of the engine oil to the seal of the new oil filter.
7. Align the new oil filter to the oil-filter adapter and rotate the filter clockwise until the seal of the oil filter contacts the oil cooler (Figure 44).

Note: Do not use an oil filter wrench to install the new oil filter. The wrench can dent an oil filter, causing a leak.

8. Hand tighten the oil filter an additional 1/2 turn (Figure 44).
9. Remove the small oil pan from under the oil filter.
10. Check the engine oil level; refer to Checking the Engine Oil Level (page 38).
11. Install the side panel; refer to Installing the Side Panels (page 36).

Servicing the Air-cleaner System

Important: Do not remove the elements from the machine to check for a restriction; always follow the instructions in the following procedures.

Note: Do not replace an old air cleaner element with an element that is more than 5 years old; check the date of manufacture on the end cap of the element.

Note: Every time you service the air cleaner system, ensure that all hose connections and flanges are air tight. Replace all damaged parts.

Servicing the Dust Valve

Service Interval: Every 50 hours

Squeeze the sides of the dust valve to release any collected water, dust, or dirt from the valve (Figure 45).

Note: Ensure that there are no obstructions inside the dust valve.

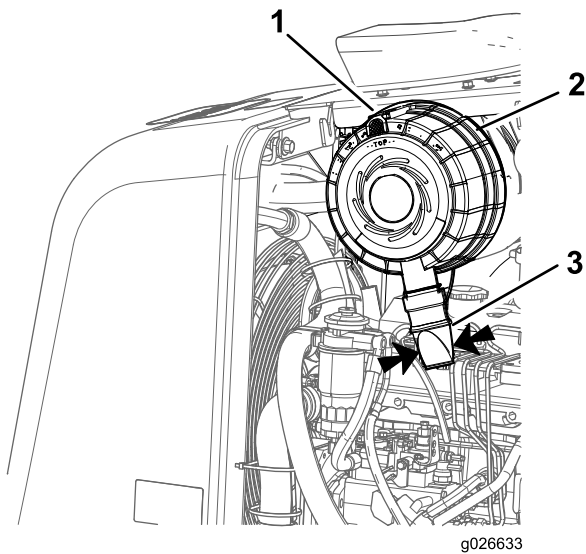

Figure 45

- 1. Latch
- 2. Air-cleaner cover
- 3. Dust valve

Removing the Air-cleaner Cover

1. Remove the left side panel; refer to Removing the Side Panels (page 35).
2. Pull the latch for the air-cleaner cover outward (Figure 45).
3. Rotate the cleaner cover counterclockwise so that the dust cap is at the 7 o'clock position (Figure 47).

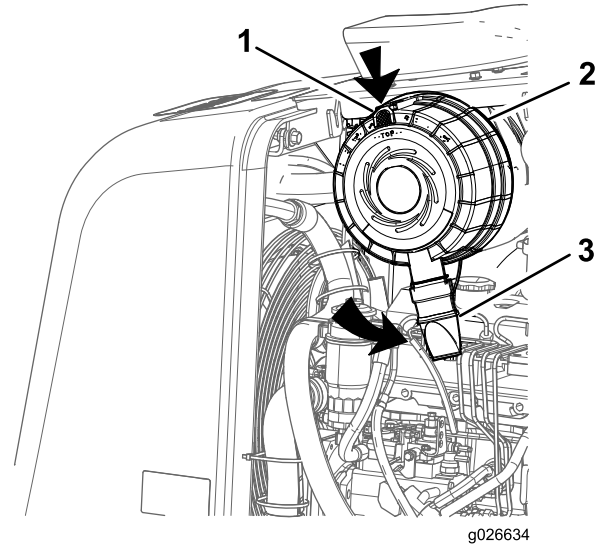

Figure 47

- 1. Latch
- 2. Air-cleaner cover
- 3. Dust cap

Checking the Restricted Air-cleaner Light

Service Interval: Before each use or daily

1. Start the engine; refer to Starting the Engine (page 25).
2. Check the restricted air-cleaner light on the instrument cluster (Figure 46).

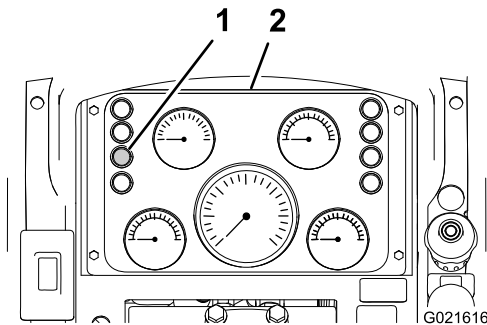

Figure 46

- 1. Restricted air-cleaner light
- 2. Instrument cluster

3. Replace the air-cleaner element(s) as follows:
 - A. Replace the primary air-cleaner element; refer to Replacing the Primary Element (page 41).
 - B. Repeat steps 1 and 2.
 - C. If the restricted air-cleaner light still comes on, replace the secondary air-cleaner element; refer to Replacing the Secondary Element (page 41).

4. Pull the air-cleaner cover away from the cleaner housing to remove the cover.
5. Clean the inside of the cover with a clean damp cloth.

Installing the Air-cleaner Cover

1. Align the dust cap on the air-cleaner cover to the 7 o'clock position.
2. Align the air-cleaner cover onto the cleaner housing.
3. Rotate the air-cleaner cover clockwise so that the dust cap is at the 8 o'clock position (Figure 45).
4. Push the latch for the air-cleaner cover inward until the cover is fully seated (Figure 45).
5. Install the left side panel; refer to Installing the Side Panels (page 36).

Replacing the Primary Element

Important: Replace the primary air-cleaner element when the restricted air-cleaner light comes on.

1. Remove the air-cleaner cover; refer to Removing the Air-cleaner Cover (page 40).
2. Pull the primary air-cleaner element outward and remove it from the air-cleaner housing (Figure 48).

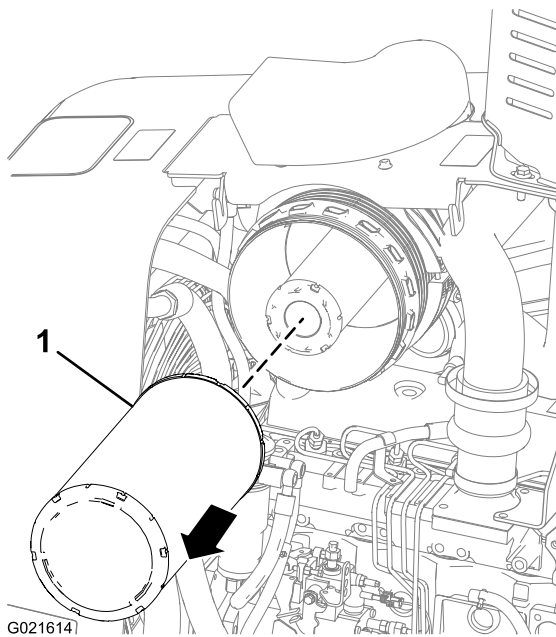

Figure 48

1. Primary air-cleaner element

Note: Discard the old air-cleaner element.

3. Use a clean damp cloth to clean the inside of the cleaner housing.
4. Use a light to inspect the new element for damage; if the element is damaged, replace it.

Note: Check the date of manufacture on the end of the new air-cleaner element. Do not install an element that is more than 5 years old.

5. Write the current date and the engine hours on the end of the element with a permanent marking pen.

6. Insert the new primary air-cleaner element into the air-cleaner housing (Figure 48).

Note: Ensure that the air-cleaner element is fully seated in the housing.

7. Install the air-cleaner cover; refer to Installing the Air-cleaner Cover (page 41).
8. Check the restricted air-cleaner light; refer to Checking the Restricted Air-cleaner Light (page 40).

Replacing the Secondary Element

Note: Replace the secondary air-cleaner element after you have replaced the primary air-cleaner element 3 times or if the air-cleaner restriction light comes on while the engine is running and you have already replaced primary air-cleaner element.

Important: Do not clean either the primary element or the secondary element.

1. Remove the air-cleaner cover; refer to Removing the Air-cleaner Cover (page 40).
2. Pull the primary air-cleaner element outward and remove it from the air-cleaner housing; refer to Replacing the Primary Element (page 41).

Pull the secondary air-cleaner element outward and remove it from the air-cleaner housing. (Figure 49).

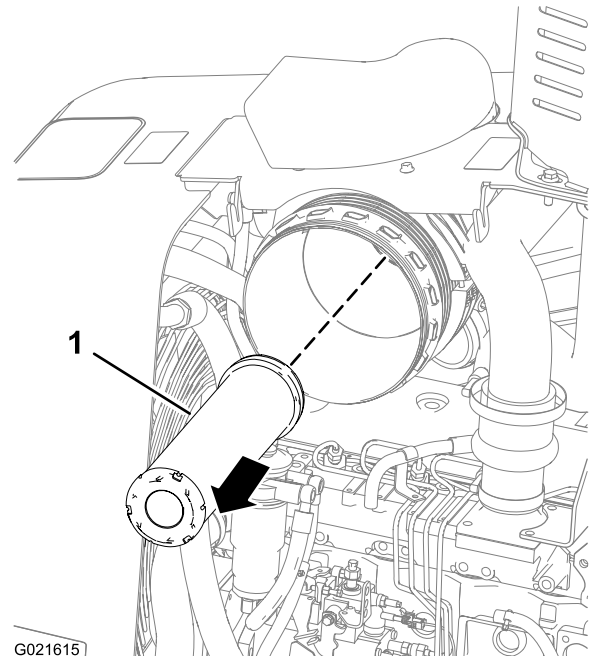

Figure 49

1. Secondary air-cleaner element

Note: Discard the old air-cleaner element.

3. Clean the inside of the cleaner housing with a clean, damp cloth.
4. Insert the new secondary air-cleaner element into the air-cleaner housing (Figure 49).

Note: Ensure that the secondary element is fully seated in the housing.

5. Insert the primary air-cleaner element into the air-filter housing; refer to Replacing the Primary Element (page 41).

Note: Ensure that the primary element is fully seated in the housing.

6. Install the air-cleaner cover; refer to Installing the Air-cleaner Cover (page 41).
7. Check the restricted air-cleaner light; refer to Checking the Restricted Air-cleaner Light (page 40).

Fuel System Maintenance

Servicing the Fuel System

Draining the Fuel-water Separator

Service Interval: Every 50 hours

1. Remove the left side panel; refer to Removing the Side Panels (page 35).
2. Place a small drain pan under the secondary fuel filter (Figure 50).

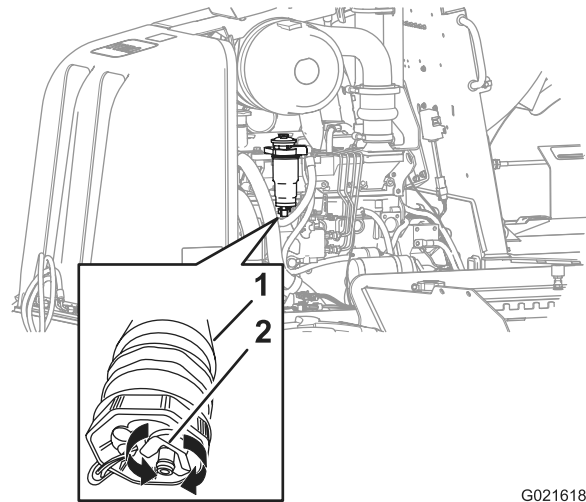

G021618

Figure 50

1. Secondary-fuel filter
2. Drain valve

3. Rotate the drain valve at the bottom of the secondary fuel filter 2 or 3 turns counterclockwise, and drain any water and sediment from the fuel-water separator of the fuel filter (Figure 50).

Note: If the fuel-water separator has any water or sediment, drain the water and sediment from the fuel tank; go to step 2.

4. When clean fuel appears, rotate the drain valve clockwise until it is closed (Figure 50).

Note: Do not overtighten the drain valve.

5. Bleed the fuel system; refer to Bleeding the Fuel System (page 44).
6. Install the left side panel; refer to Installing the Side Panels (page 36).

Draining Water from the Fuel Tank

1. Place a drain pan under the drain plug in the fuel tank.
2. Unscrew the drain plug from the fuel tank and drain the water (Figure 51).

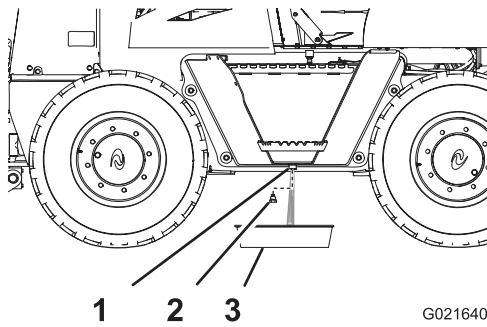

Figure 51

G021640

1. Fuel tank
2. Drain plug
3. Drain pan

3. When clean fuel appears, install the drain plug and tighten it securely (Figure 51).
4. Check the fuel tank drain plug for leaks.

Siphoning Water from the Fuel Tank

Note: Siphoning water from the fuel tank is an alternative to draining water from the fuel tank; refer to Draining Water from the Fuel Tank (page 42).

1. Remove the fuel cap from the fuel tank (Figure 52).

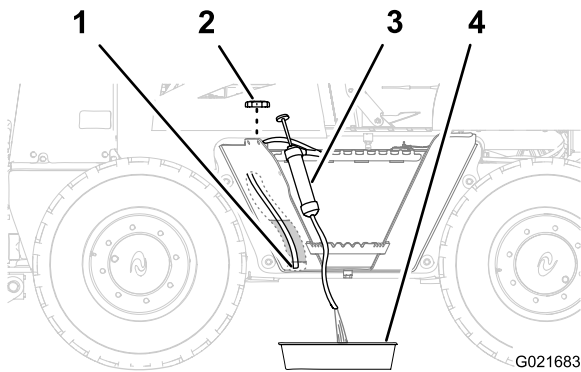

Figure 52

G021683

1. Intake hose (bottom of the tank)
 2. Fuel cap
 3. Siphoning equipment
 4. Drain pan
2. Route the intake hose of the siphoning equipment through the filler neck of the fuel tank and to the bottom of the tank (Figure 52).
 3. Direct the discharge hose of the siphoning equipment into a drain pan (Figure 52).
 4. Siphon the tank until clean fuel appears.
 5. Remove the siphoning equipment from the tank.
 6. Install the fuel cap onto the filler neck of the fuel tank (Figure 52).

Replacing the Fuel Filters

Replacing the Secondary Fuel Filter

Service Interval: Every 500 hours

1. Remove the left side panel; refer to Removing the Side Panels (page 35).
2. Remove the secondary fuel filter and fuel-water separator as follows:
 - A. Clean the secondary fuel filter and the surrounding area.
 - B. Completely drain the fuel-water separator; refer to Draining the Fuel-water Separator (page 42).
 - C. Firmly grasp the secondary fuel-filter element, rotate the water sensor counterclockwise, and remove the water sensor (Figure 53).

Note: Retain the water sensor, but discard the O-ring.

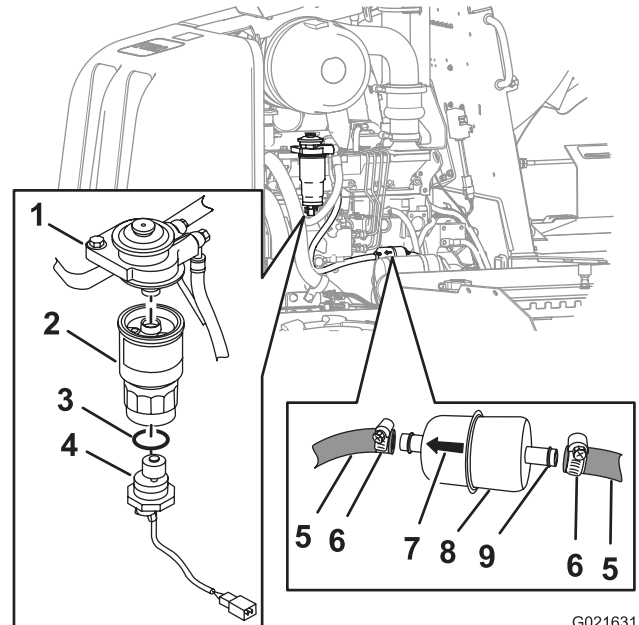

Figure 53

G021631

1. Filter adapter
2. Secondary filter element
3. O-ring
4. Water sensor
5. Fuel hose
6. Hose clamp
7. Arrow
8. Primary fuel filter
9. Fitting

- D. Firmly grasp the secondary fuel-filter element, rotate it counterclockwise, and remove it from the filter adapter (Figure 53).

Note: Discard the filter element.

- E. Clean the filter adapter with a clean rag.

Important: Do not use a filter wrench to tighten the filter. You could damage the filter and cause a leak.

3. Install the secondary fuel filter and fuel-water separator as follows:
 - A. Apply a thin film of clean fuel to the seal on the fuel-filter element.
 - B. Align the new secondary filter element to the filter adapter (Figure 53).
 - C. Rotate the secondary filter element until the seal contacts the filter adapter, then rotate the filter element an additional 3/4 turn.
 - D. Slip the new O-ring over the water sensor (Figure 53).
 - E. Align the water sensor to the bottom of the secondary fuel filter (Figure 53).
 - F. Firmly grasp the secondary filter element, and rotate the water sensor clockwise until it is hand tight (Figure 53).
4. Bleed the fuel system; refer to Bleeding the Fuel System (page 44).
5. Start the engine and check for leaks at the fuel filter.
6. Install the left side panel; refer to Installing the Side Panels (page 36).

Replacing the Primary Fuel Filter

Service Interval: Every 500 hours

1. Remove the left side panel; refer to Removing the Side Panels (page 35).
2. Place clean rags under the primary fuel filter.
3. Loosen the hose clamps and separate the primary fuel filter from the fuel hoses (Figure 53).

Note: Do not remove the hose clamps from the hoses.

Note: Discard the fuel filter.

4. Align the new primary fuel filter to the hoses with the arrow printed on the filter pointing forward (Figure 53).
5. Slip the hoses over the hose fitting of the primary fuel filter, and tighten the hose clamps (Figure 53).
6. Bleed the fuel system; refer to Bleeding the Fuel System (page 44).
7. Start the engine and check for leaks at the fuel filter.
8. Install the left side panel; refer to Installing the Side Panels (page 36).

Bleeding the Fuel System

⚠ WARNING

The fuel system is under high pressure. Bleeding the system without proper precautions and training could result in injury to you from injected fluid or fire or explosion.

Read the Engine Owner's Manual for the proper bleeding procedure or contact your Authorized Toro Service Dealer.

Note: Remove air from the fuel system whenever you do any of the following:

- Drain the fuel-water separator
- Replace the fuel filter
- Run the engine until the fuel tank is empty
 1. Ensure that both the engine and the exhaust system are cool.
 2. Ensure that the fuel tank is 1/4 full.
 3. Rotate the battery-disconnect switch clockwise to the On position.
 4. Locate the priming button on the top of the filter adapter for the secondary fuel filter (Figure 54).

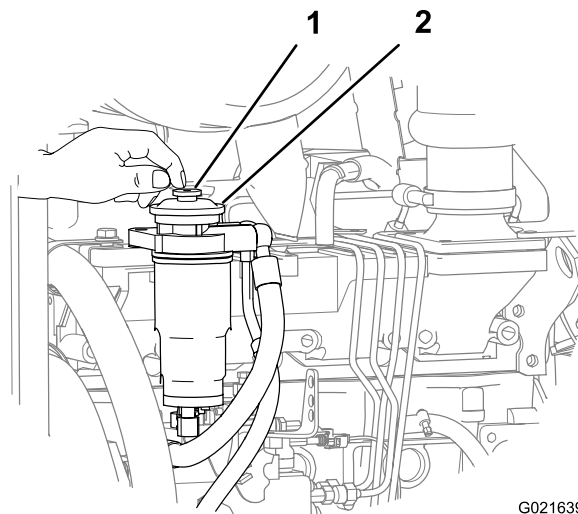

Figure 54

1. Priming button
2. Filter adapter

5. Press down and release the priming button repeatedly until you feel resistance (Figure 54).
6. Start the engine; refer to Starting the Engine (page 25).

Note: If the engine does not start after priming the fuel system and making several attempts to start the engine, bleed the high-pressure fuel lines; refer to your engine owner's manual or contact your Authorized Toro Service Dealer for assistance.

Electrical System Maintenance

Maintaining the Battery

Accessing the Battery

Remove the battery cover as follows:

1. Ensure that the battery-disconnect switch is in the Off position; refer to Battery-disconnect Switch (page 21).
2. Remove the bolt that secures the battery cover to the ROPS plate (Figure 55).

Note: The battery cover is located between the utility-traction control and the left fender.

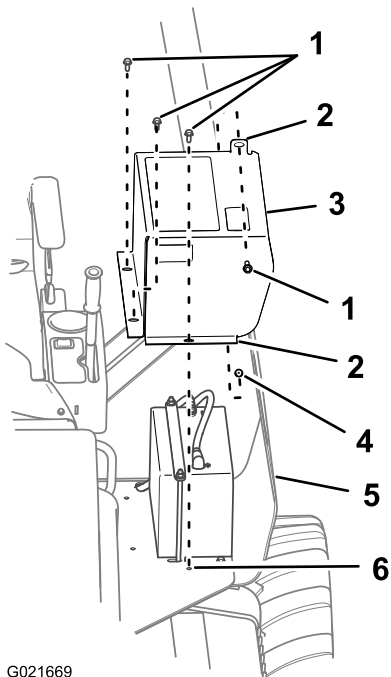

Figure 55

- | | |
|------------------|----------------------|
| 1. Bolts | 4. ROPS plate |
| 2. Flange | 5. Fender |
| 3. Battery cover | 6. Operator platform |

3. Remove the 3 bolts that secure the battery cover to the operator platform, and remove the battery cover (Figure 55).

Install the battery cover as follows:

1. Align the holes in the mounting flanges for the battery cover with the holes in the operator platform around the battery (Figure 55).
2. Secure the battery cover to the ROPS plate with a bolt (Figure 55).
3. Secure the battery cover to the operator platform with the 3 bolts that you previously removed (Figure 55).

Servicing the Battery

⚠ WARNING

Exposure to battery acid or a battery explosion can cause serious personal injury.

Before you service a battery, always wear face protection, protective gloves, and protective clothing.

⚠ WARNING

A battery contains sulfuric acid, which can cause serious burns; and they can produce explosive gases.

- Avoid contact with skin, eyes, or clothing; flush affected areas with water.
- If taken internally, drink large quantities of water or milk. *Do not* induce vomiting. Seek medical attention immediately.
- Keep sparks, flames, and lit cigarettes and cigars away from the battery.
- Ventilate the battery when you are charging it or using it in an enclosed area.
- Wear eye protection when working near a battery.
- Wash your hands after handling a battery.
- Keep the battery out of the reach of children.

⚠ WARNING

A frozen battery can be explosive, causing personal injury to you or others in the area, if you try to charge the battery or try to jump start the battery and run the engine.

To prevent the battery electrolyte from freezing, keep the battery fully charged.

⚠ WARNING

Sparks or a flame can cause hydrogen gas in a battery to explode.

When you disconnect the battery cables, always disconnect the negative (-) cable first.

When you connect the battery cables, always connect the negative (-) cable last.

Do not short-circuit the battery posts with a metal object.

Do not weld, grind, or smoke near a battery.

Note: The electrical system in this machine is 12 volts.

Connecting a Booster Battery

⚠ WARNING

Charging the battery produces gasses that can explode.

Never smoke near the battery and keep sparks and flames away from battery.

Note: This procedure requires 2 people to perform. Ensure that the person making the connections wears the proper face protection and protective gloves and clothing.

1. Ensure that all controls are in the Neutral position and that the parking brake is in the On position.
2. Sit in the operator seat and have the other person make the connections.

Note: Ensure that the jumper battery is a 12-volt battery.

Important: If you are using another machine for power, ensure that the 2 machines are not touching each other.

3. Prepare to start the engine; refer to steps 1 through 6 of Starting the Engine (page 25).
4. Remove the cover from the jump post (Figure 56).

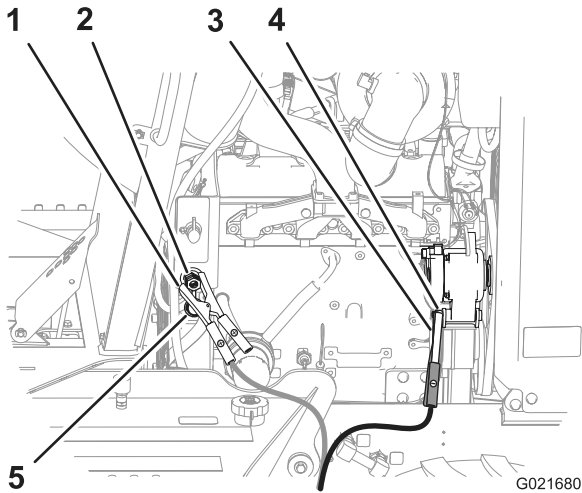

Figure 56

- | | |
|----------------------------------|----------------------------------|
| 1. Jumper-cable clamp (positive) | 4. Jumper-cable clamp (negative) |
| 2. Jump post | 5. Cover |
| 3. Ground point (alternator nut) | |

5. Connect the positive (+) jumper cable to the jump post (Figure 56).
6. Connect the negative (-) jumper cable to a ground point, such as the nut at the pivot point for the alternator (Figure 56).
7. Start the engine; refer to steps 7 through 10 in Starting the Engine (page 25).

Note: If the engine starts and then stops, **do not** operate the starter motor until the starter motor stops turning. **Do not** operate the starter motor for more than 30 seconds at one time. Wait 30 seconds before operating the starter motor to cool the motor and to build up the charge in the battery.

8. When the engine starts, have the other person disconnect the negative (-) jumper cable from the frame and then disconnect the positive (+) jumper cable.

Charging the Battery

⚠ WARNING

Charging the battery produces gasses that can explode.

Never smoke near the battery, and keep sparks and flames away from the battery.

Important: Always keep the battery fully charged. This is especially important to prevent battery damage when the temperature is below 32°F (0°C).

1. Clean the exterior of the battery case and the battery posts.

Note: Connect the leads of the battery charger to battery posts before connecting the charger to the electrical source.

2. Connect the positive lead of the battery charger to the positive-battery post (Figure 57).

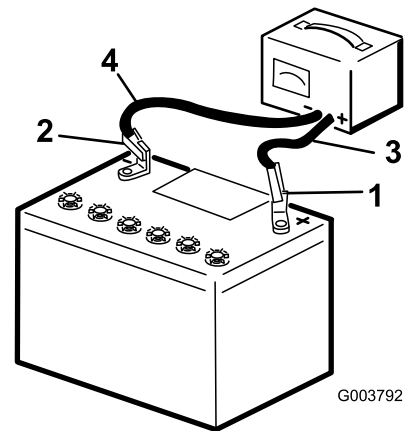

Figure 57

- | | |
|--------------------------|---------------------------|
| 1. Positive-battery post | 3. Red (+) charger lead |
| 2. Negative-battery post | 4. Black (-) charger lead |

3. Connect the negative lead of the battery charger to the negative-battery post (Figure 57).
4. Connect the battery charger to the electrical source.

Important: Do not overcharge the battery.

Note: Charge the battery as shown in the following table:

Battery Charging Table

Charger Setting	Charging Time
4 to 6 amperes	30 minutes
25 to 30 amperes	10 to 15 minutes

5. When the battery is fully charged, unplug the charger from the electrical source, then disconnect the charger leads from the battery posts (Figure 57).

Replacing a Fuse

1. Remove the right side panel; refer to Removing the Side Panels (page 35).
2. Rotate the battery-disconnect switch counterclockwise to the Off position (Figure 58).

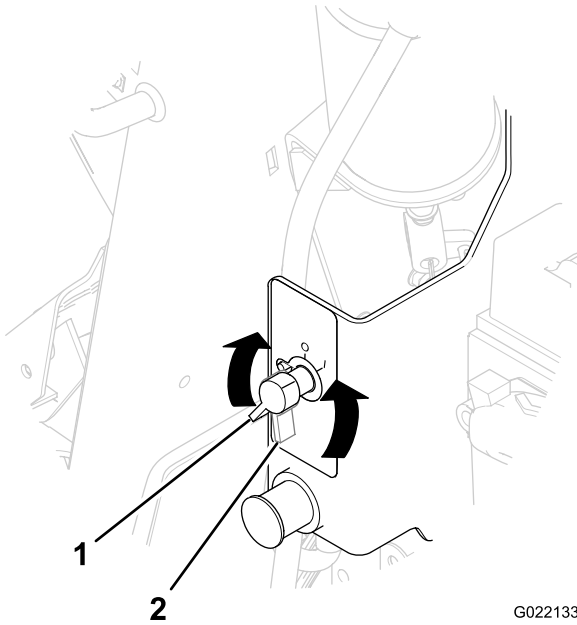

Figure 58

G022133

1. Battery-disconnect switch in the On position
2. Battery-disconnect switch in the Off position

3. Replace the open (blown) fuse in the fuse block with a new fuse that has an equivalent amperage value (Figure 59).

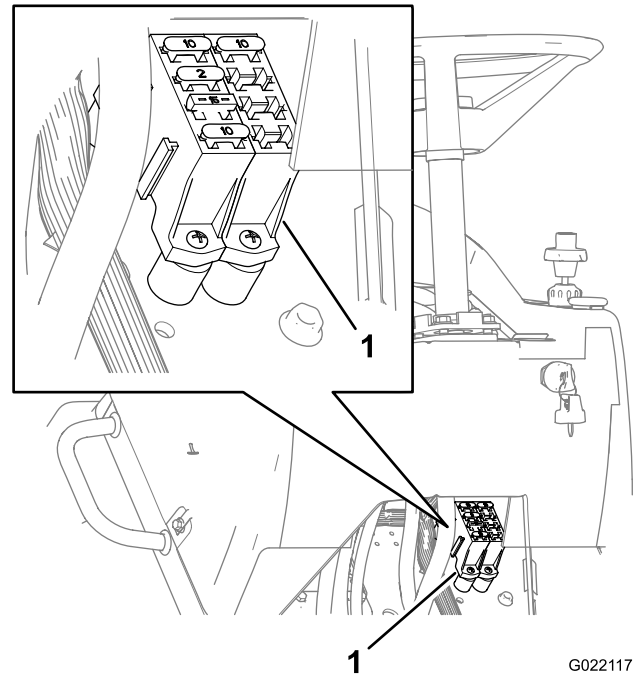

Figure 59

G022117

1. Fuse block

4. Rotate the battery-disconnect switch clockwise to the On position (Figure 17).
5. Install the right side panel; refer to Installing the Side Panels (page 36).

Drive System Maintenance

Servicing the Tires

⚠ WARNING

Exploding tires and/or rim parts can cause injury or death.

Keep yourself and others out of the area of danger. Stand on the tread side of the tire. Always fill the tires to the correct air pressure, and follow the instructions in this manual for adding air or servicing the tires.

⚠ WARNING

Do not weld the wheel or rim with the tire installed. Welding with an explosive air/gas mixture can ignite, causing serious injury or death, regardless of whether the tire is inflated or deflated.

Removing the air or breaking the bead is not adequate; you must completely remove the tire from the rim before welding.

⚠ WARNING

An explosive separation of the tire and/or rim parts can cause injury or death.

Have a qualified tire mechanic service the tire.

Checking the Tires and Wheels

Service Interval: Before each use or daily

1. Check each tire for embedded objects, separated plies, missing tread, bulges, or a damaged bead, and replace it, if necessary.
2. Check each wheel for signs of unusual bending or damage, and replace it, if necessary.

Maintaining the Air Pressure in the Tires

Service Interval: Every 50 hours

Important: Maintain the air pressure in the tires at 310 kPa (45 psi).

1. Measure the air pressure in the tires; if the tire pressure is not at the recommended pressure, complete the rest of this procedure.

Important: Use an air hose with a remote shutoff valve and a self-locking chuck.

Note: Before you add air, ensure that the tire is properly installed on the machine, or put the wheel in a restraining device, such as a tire inflation cage.

2. Remove the cap from the valve stem.
3. Attach the self-locking chuck of the air hose to the valve stem.
4. When inflating the tire while it is mounted to the machine, stand behind the tread of the tire.

Note: Ensure that all persons are away from the side of the tire before you start to add air.

5. Open the remote shutoff valve to inflate the tire to the specified pressure, then close the valve.

Important: Do not inflate the tire more than the recommended pressure.

6. Remove the air chuck from the valve stem.
7. Install the cap on the valve stem.

Maintaining the Tires and Wheels

Always have a qualified tire technician service the tires and wheels of this machine. To prevent accidents, use a restraining device (such as a tire inflation cage), the correct equipment, and the correct procedure.

Important: There are 2 different tire-tread pattern and wheel combinations; the left-side tires and the right-side tires are different. Ensure that the tread direction of the tire and the valve stem in the wheel are correctly aligned before installing the tire to the rim.

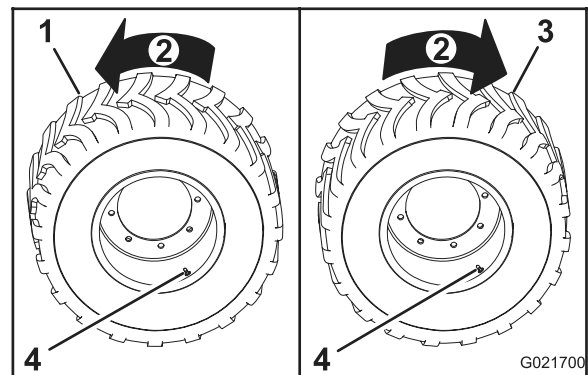

Figure 60

- | | |
|-------------------|--------------------|
| 1. Left-side tire | 3. Right-side tire |
| 2. Forward | 4. Valve stem |

Torquing the Wheel Nuts

1. Ensure that the mounting flange of the wheel is flush against the mounting flange of the axle.
2. Incrementally torque the wheel nuts for each wheel as follows:
 - A. Torque the all wheel nuts to 100 N-m (75 ft-lb) in the sequence shown in Figure 61.

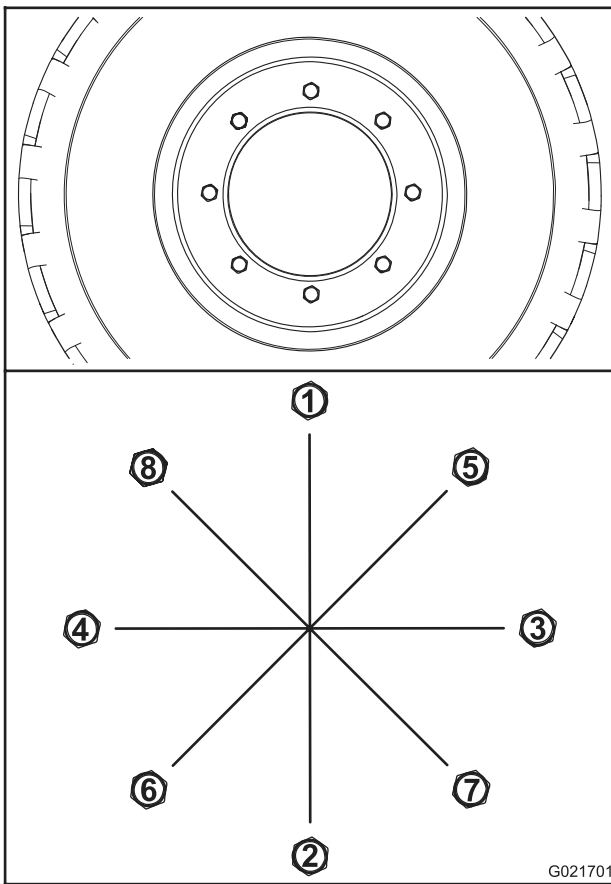

Figure 61

- B. Torque all the nuts to 200 N-m (150 ft-lb) in the sequence shown in Figure 61.
- C. Torque all the nuts to 300 N-m (225 ft-lb) in the sequence shown in Figure 61.

Servicing the Axles and the Transmission

Checking the Oil Level in the Wheel Hubs

Service Interval: After the first 100 hours
Every 250 hours

Note: Have another person help you align the oil plugs in the axles when you service the axle oil.

1. Ensure that the machine is on a level surface and that all the attachments are in the transport position.
2. Move the machine forward or backward until the plug for the wheel hub is at either the 3 o'clock or 9 o'clock position (Figure 62).

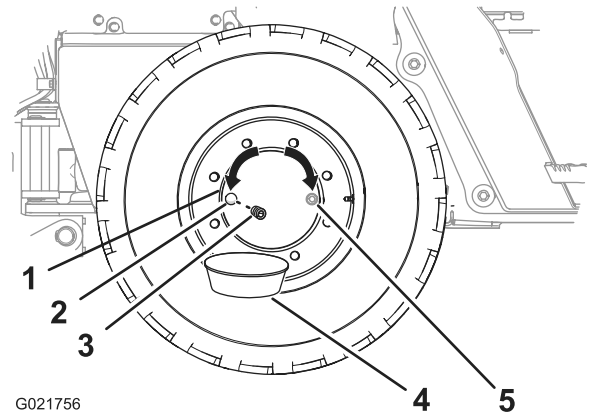

Figure 62

1. Wheel hub
2. Oil port at the 9 o'clock position
3. Plug
4. Drain pan
5. Oil port at the 3 o'clock position (alternative)

3. Stop the engine, set the parking brake, and remove the ignition key.
4. Place a drain pan under the drain port in the wheel hub (Figure 62).
5. Remove the plug from the wheel hub (Figure 62).
6. Check that the oil level is at the bottom of the threads of the oil port (Figure 62).
 - If the oil level is too high, allow the oil to drain from the oil port.
 - If the oil level is too low, add oil to the wheel hub through the oil port; refer to step 6 in Changing the Wheel Hub Oil (page 49).
7. Check the condition of the O-ring on the plug.

Note: Replace the O-ring if it is worn or damaged.
8. Install the plug in the oil port of the wheel hub (Figure 62).
9. Repeat steps 2 through 8 for the other wheel hubs.

Changing the Wheel Hub Oil

Service Interval: After the first 200 hours
Every 1,000 hours

Oil specification: SAE 80W140 API classification level GL4

Wheel hub oil capacity: approximately 0.62 L (0.65 US qt)

Toro Premium Gear Oil is available from an Authorized Toro Service Dealer. See the parts catalog for part numbers.

Note: If possible, change the oil when it is warm.

1. Move the machine forward or backward until the oil plug for the wheel hub is at the 6 o'clock position (Figure 63).

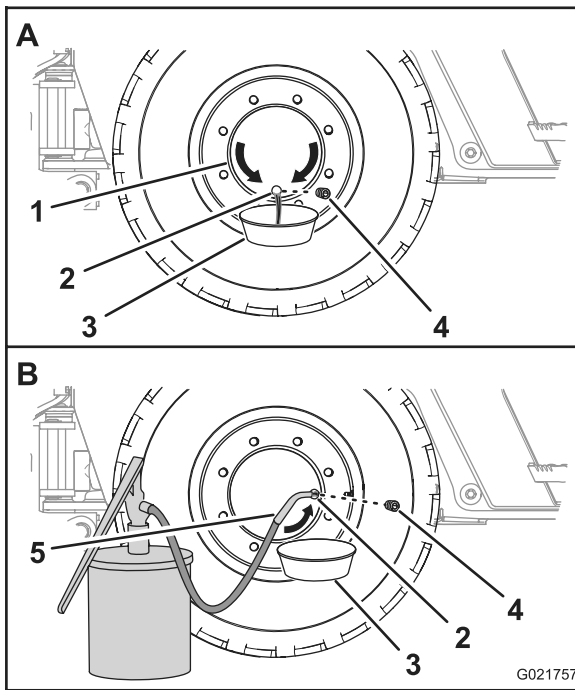

Figure 63

- | | |
|---------------------------------------|---------------------------------------|
| 1. Wheel hub | 4. Oil port at the 3 o'clock position |
| 2. Oil port at the 6 o'clock position | 5. Plug |
| 3. Drain pan | 6. Oil servicing equipment |

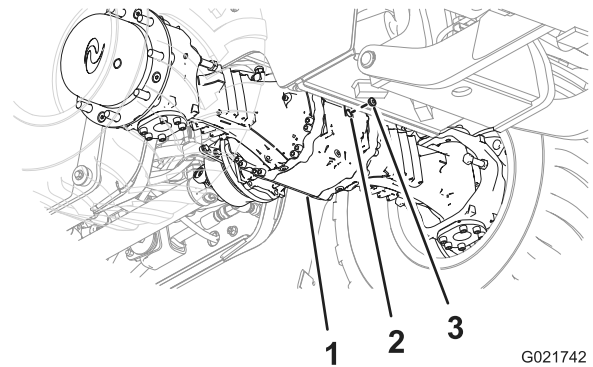

Figure 64
Front Axle

- | | |
|--------------------------------|---------|
| 1. Pinion housing (front axle) | 3. Plug |
| 2. Sight port | |

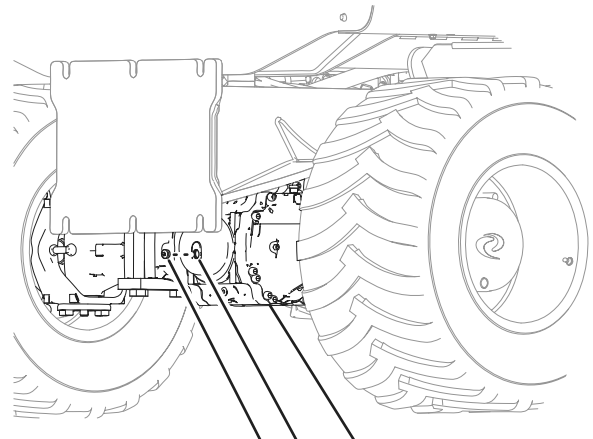

Figure 65
Rear Axle

- | | |
|--------------|-------------------------------|
| 1. Plug | 3. Pinion housing (rear axle) |
| 2. Site port | |

- Look through the sight port and check that the oil level in the axle is level with the bottom of the threads of the port (Figure 64 and Figure 65).

Note: Use a flashlight and a mirror to help you see the oil level.

- If the oil level is too high, allow the oil to drain from the sight port.
- If the oil level is too low, add oil to the pinion housing and axle through the sight port; refer to steps 6 and 7 in Changing the Oil in the Axles (page 51).

- Clean the threads of the sight plug.
- Apply PTFE thread sealing tape to the threads of the plug.
- Install the sight plug into the sight port in the pinion housing of the axle (Figure 64 and Figure 65).

Checking the Oil Level in the Axles

Service Interval: After the first 100 hours

Every 250 hours

- Place a drain pan under the pinion housing of the axle.
- Remove the plug from the sight port in the pinion housing of the axle.

Changing the Oil in the Axles

Service Interval: After the first 200 hours

Every 1,000 hours

Oil specification: SAE 80W140 API classification level GL4

Front axle oil capacity: approximately 3.8 L (4.0 US qt)

Rear axle oil capacity: approximately 3.8 L (4.0 US qt)

Toro Premium Gear Oil is available from an Authorized Toro Service Dealer. See the parts catalog for part numbers.

1. Place a drain pan under the pinion housing of the axle (Figure 66 and Figure 67).

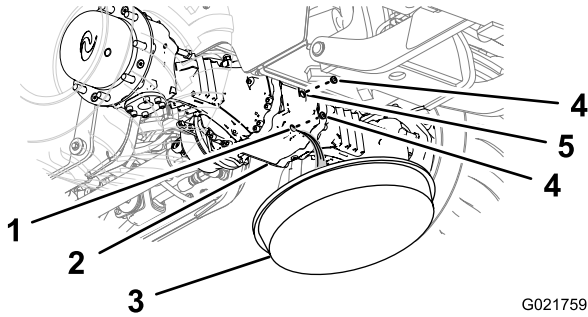

Figure 66
Front Axle

G021759

- | | |
|-------------------|---------------|
| 1. Drain port | 4. Plug |
| 2. Pinion housing | 5. Sight port |
| 3. Drain pan | |

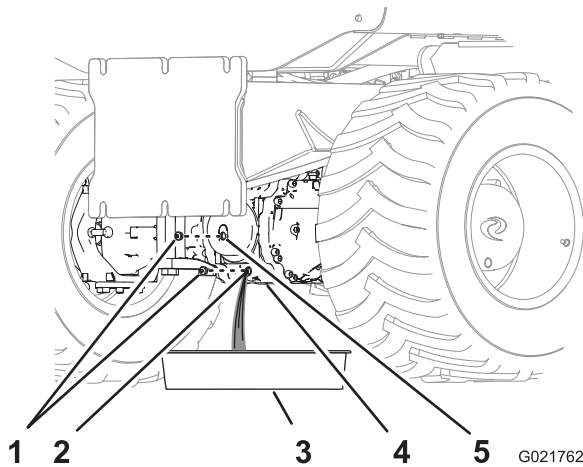

Figure 67
Rear Axle

G021762

- | | |
|---------------|-------------------|
| 1. Plug | 4. Pinion housing |
| 2. Drain port | 5. Sight port |
| 3. Drain pan | |

2. Remove the plugs from the sight port and the drain port of the pinion housing (Figure 66 and Figure 67).

Note: Allow the oil to drain completely from the pinion housing and axle.

3. Clean the threads of the plugs.
4. Apply PTFE thread sealing tape to the threads of the plugs.
5. Install one of the plugs into the drain port (Figure 68 and Figure 69).

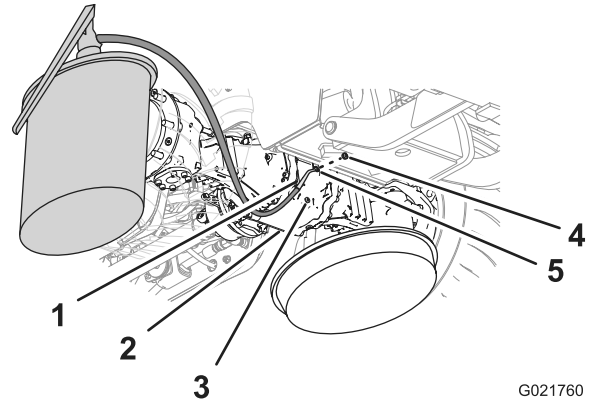

Figure 68
Front Axle

G021760

- | | |
|----------------------------|----------------------|
| 1. Oil servicing equipment | 4. Plug (sight port) |
| 2. Pinion housing | 5. Sight port |
| 3. Plug (drain port) | |

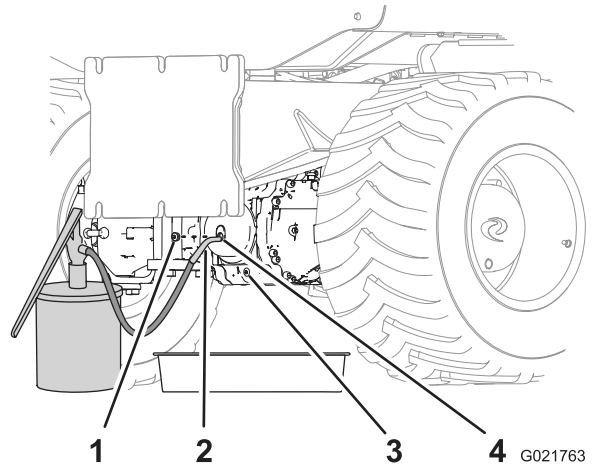

Figure 69
Rear Axle

G021763

- | | |
|----------------------------|----------------------|
| 1. Plug | 3. Plug (drain port) |
| 2. Oil servicing equipment | 4. Sight port |

6. Fill the pinion housing and axle with the specified oil through the sight port until the oil is level with the threads at the bottom of the port (Figure 68 and Figure 69).
7. Wait a few minutes for the oil to settle, then add more oil as necessary.

Note: Continue to add oil until the oil level stabilizes and is at the bottom of the threads of the sight port.

8. Install the remaining plug into the sight port of the pinion housing (Figure 68 and Figure 69).

Checking the Oil Level in the Transmission

Service Interval: After the first 100 hours

Every 250 hours

1. Place a drain pan under the back side of the transmission housing (Figure 70).

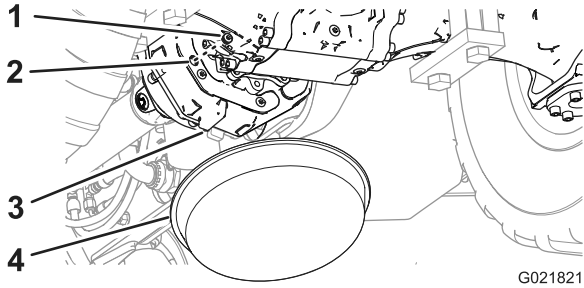

Figure 70

- | | |
|---------------|-------------------------|
| 1. Plug | 3. Transmission housing |
| 2. Sight port | 4. Drain pan |

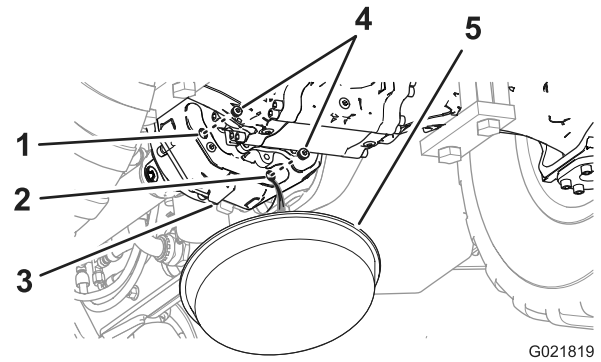

Figure 71

- | | |
|-------------------------|--------------|
| 1. Sight port | 4. Plug |
| 2. Drain port | 5. Drain pan |
| 3. Transmission housing | |

2. Remove the plugs from the drain port and the sight port in the transmission housing (Figure 71).

Note: Allow the oil to drain completely from the pinion housing and axle.

3. Clean the threads of the plugs.
4. Apply PTFE thread-sealing tape to the threads of the plugs.
5. Install one of the plugs into the drain port of the transmission (Figure 72).

Note: Use a flashlight and a mirror to help you see the oil level.

- If the oil level is too high, allow the oil to drain from the sight port.
- If the oil level is too low, add oil to the transmission through the sight port; refer to steps 6 and 8 in Changing the Oil in the Transmission (page 52).

4. Clean the threads of the sight plug.
5. Apply PTFE thread sealing tape to the threads of the plug.
6. Install the sight plug into the sight port of the transmission housing (Figure 70).

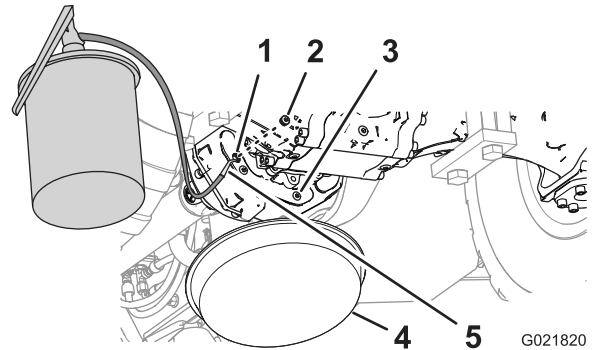

Figure 72

- | | |
|-------------------------|----------------------------|
| 1. Sight port | 4. Drain pan |
| 2. Plug | 5. Oil servicing equipment |
| 3. Transmission housing | |

6. Fill the transmission with the specified oil through the sight port until the oil is level with the threads at the bottom of the port (Figure 72).
7. Wait a few minutes for the oil to settle, then add more oil as necessary.

Note: Continue to add oil until the oil level is stabilizes and at the bottom of the threads of the sight port.

8. Install the remaining plug in the sight port of the transmission (Figure 72).

Changing the Oil in the Transmission

Service Interval: After the first 200 hours

Every 1,000 hours

Oil specification: SAE 80W140 API classification level GL4

Transmission oil capacity: approximately 1.7 L (1.8 US qt)

Toro Premium Gear Oil is available from an Authorized Toro Service Dealer. See the parts catalog for part numbers.

Note: If possible, change the oil when it is warm.

1. Place a drain pan under the back side of the transmission housing (Figure 71).

Cleaning the Axle Breathers

Service Interval: Every 300 hours

1. Clean the area around the breathers with a cleaning solvent (Figure 73 and Figure 74).

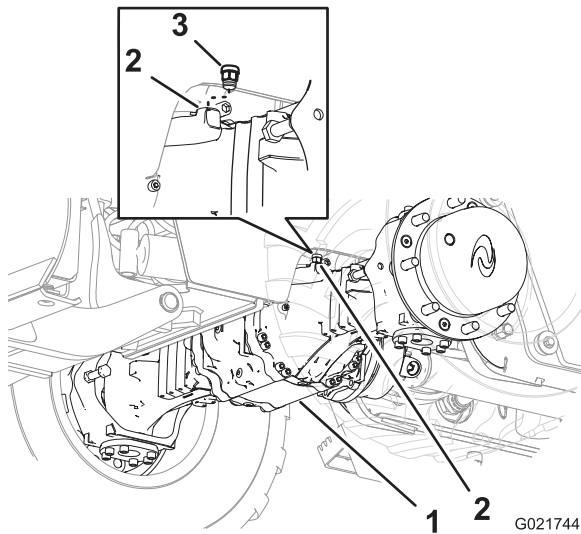

Figure 73

1. Front axle
2. Breather port
3. Breather fitting

Important: Wear face protection when using compressed air.

6. Install the breather in the front axle (Figure 73).
7. Install the breather in the rear axle (Figure 74).

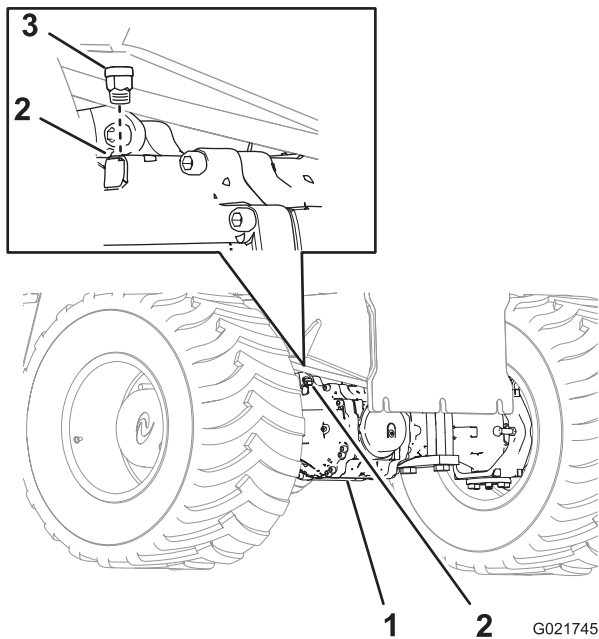

Figure 74

1. Rear axle
2. Breather port
3. Breather fitting

2. Remove the breather from the front axle (Figure 73).
3. Remove the breather from the rear axle (Figure 74).
4. Clean the breathers with a cleaning solvent.
5. Use compressed air to dry the breathers.

Cooling System Maintenance

Servicing the Cooling System

Coolant specification: a mixture of 50% ethylene glycol and 50% water

Engine and Radiator coolant capacity: 17.2 L (18.2 US qt)

⚠ WARNING

If you remove the radiator cap from a hot engine, hot coolant could spray, causing scalding.

- Wear face protection when opening the radiator cap.
- Allow the cooling system to cool down to below 50°C (120°F) before removing the radiator cap.
- Follow the instructions for checking and maintaining the engine cooling system.

⚠ WARNING

Coolant is toxic.

- Keep coolant away from children and pets.
- If you are not re-using the coolant, dispose of it according to local environmental regulations.

Checking the Coolant Level in the Reservoir

Service Interval: Before each use or daily

Note: Do not remove the radiator filler cap during this procedure.

1. Park the machine on a level surface, stop the engine, and remove the ignition key.
2. Allow the engine to cool.
3. Remove the right side panel; refer to Removing the Side Panels (page 35).
4. Check the coolant level in the reservoir (Figure 75).

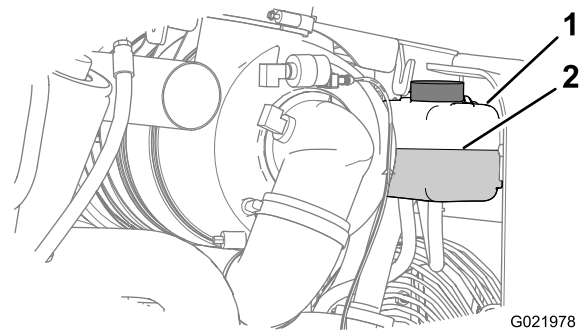

Figure 75

1. Reservoir
2. Coolant level (halfway between the Add and Full marks)

Note: Ensure that the coolant level is between the Add mark and the Full mark on the reservoir (Figure 75).

5. Add the specified coolant until the coolant level is halfway between the Add mark and the Full mark on the reservoir.

Note: Ensure that the coolant solution is thoroughly mixed before filling the reservoir.

6. Install the right side panel; refer to Installing the Side Panels (page 36).

Checking the Coolant Level in the Radiator

Service Interval: Every 50 hours

⚠ WARNING

If the engine has been running, the radiator will pressurized and the coolant inside will be hot. If you remove the cap, coolant may spray out, causing severe burns.

- Do not remove the radiator cap to check coolant levels.
- Do not remove the radiator cap when the engine is hot. Allow the engine to cool for at least 15 minutes or until the radiator cap is cool enough to touch without burning your hand.

Note: The cooling system is filled with antifreeze having a mixture of 50% ethylene glycol and 50% water.

1. Park the machine on a level surface, stop the engine, and remove the ignition key.
2. Allow the engine to cool.
3. Remove the nose panel; refer to Removing the Nose Panel (page 36).
4. Open the vent valve for the engine (Figure 76).

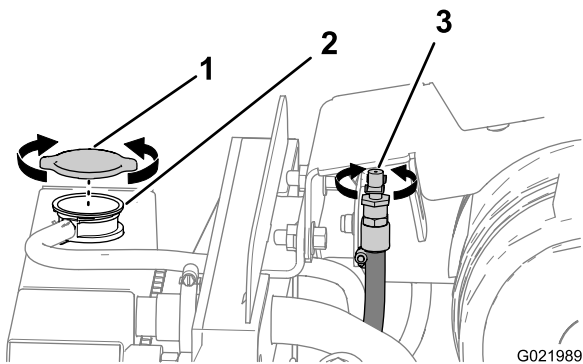

Figure 76

- | | |
|-----------------|---------------|
| 1. Radiator cap | 3. Vent valve |
| 2. Filler neck | |

- Remove the radiator cap from the filler neck of the radiator and check the coolant level (Figure 76 and Figure 77),

Note: The coolant should be up to the filler neck.

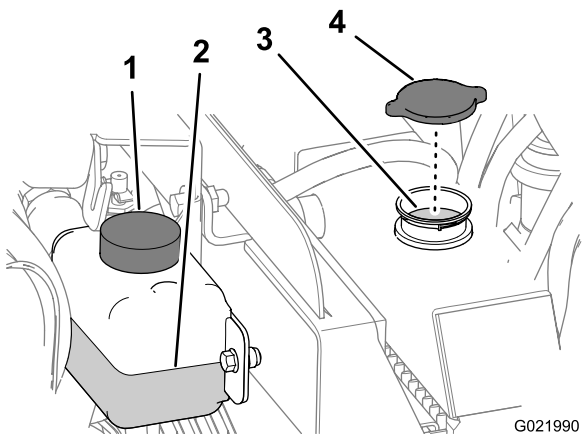

Figure 77

- | | |
|---|--|
| 1. Reservoir | 3. Coolant level (bottom of radiator neck) |
| 2. Coolant level (halfway between the Add and Full marks) | 4. Radiator cap |

- If the coolant level is low, add coolant until the level is up to the bottom of the filler neck (Figure 77).

Important: Do not overfill the radiator.

Note: If the radiator coolant level is low and the coolant reservoir level is at the Full mark, check for air leaks in the hose between the radiator and the coolant reservoir.

- Close the vent valve.
- Install the radiator filler cap, ensuring that it is tightly sealed.
- If the air temperature is below 0°C (32°F), mix the ethylene glycol and water completely by running the engine at operating temperature for 5 minutes.

Checking the Condition of Cooling System Components

Service Interval: Every 300 hours

Check the condition of the cooling system for leaks, damage, dirt, and loose hoses, and clamps. Clean, repair, tighten, and replace the components as necessary.

Checking the Concentration of the Coolant

Service Interval: Every 1,000 hours

Test the concentration of ethylene glycol based antifreeze in the coolant. Ensure that the coolant is a mixture of 50% ethylene glycol and 50% water.

Note: An antifreeze having a mixture of 50% ethylene glycol and 50% water will protect the engine to -37°C (-34°F) throughout the year.

Check the concentration of the coolant mixture to ensure that it is a mixture of 50% ethylene glycol and 50% water.

Cleaning the Cooling System

Service Interval: Every 2,000 hours/Every 2 years (whichever comes first)

Draining the Coolant from the System

Important: Do not pour coolant onto the ground or into an unapproved container that can leak.

- Remove the left and right side panels and the nose panel; refer to Removing the Side Panels (page 35) and Removing the Nose Panel (page 36).
- Remove the radiator cap (Figure 76 and Figure 77).
- Place a drain pan with a minimum capacity of 20 L (5.3 gallons) under the open end of the drain hose (Figure 78).

Note: The coolant capacity of both the engine and the radiator is 17.2 L (18.2 US qt).

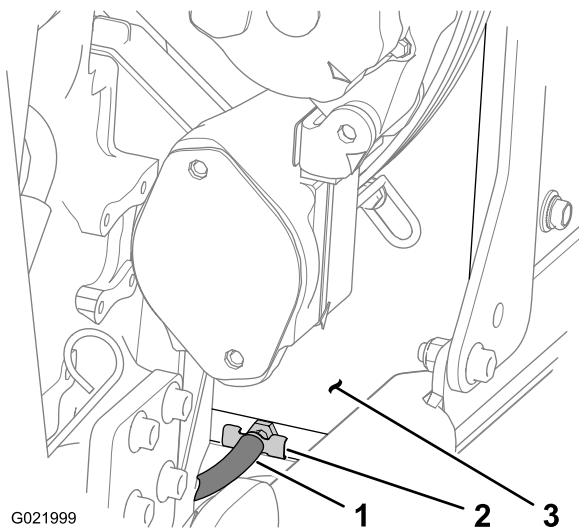

Figure 78

1. Drain hose
2. Drain valve
3. Radiator shroud (lower-left area)

4. Open the drain valve on the radiator, and allow the coolant to drain completely.

Note: Dispose of the used coolant properly according to local codes.

5. Close the drain valve (Figure 78).

Flushing the Cooling System

Engine and radiator coolant capacity: 17.2 liter (18.2 US qt)

1. Condition the cooling system as follows:
 - A. Ensure that the coolant is drained from the radiator and that the drain valve is closed.
 - B. Open the vent valve (Figure 76).
 - C. Add a cooling system cleaning solution to the to the radiator through the filler neck (Figure 79).

Note: Use cleaning solution of sodium carbonate and water (or a commercially available equivalent). Follow the directions that come with the cleaning solution.

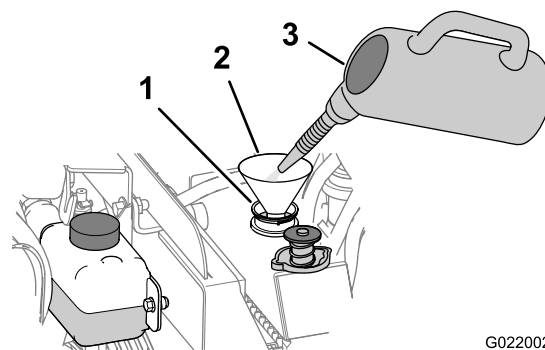

Figure 79

1. Coolant system cleaning solution
2. Funnel
3. Filler neck (radiator)

- D. Close the vent valve.

Important: Do not install the radiator cap.

- E. Operate the engine for 5 minutes or until the coolant temperature gauge in the instrument cluster indicates 82°C (180°F), then stop the engine (Figure 80).

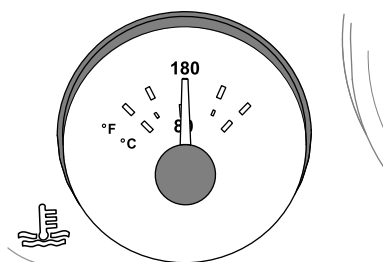

Figure 80

CAUTION

The cleaning solution is hot and can cause burns.

Stay away from the discharge end of the coolant drain hose.

- F. Open the drain valve and drain the cleaning solution into a drain pan (Figure 78).
- G. Close the drain valve.
2. Flush the cooling system as follows:
 - A. Open the vent valve (Figure 76).
 - B. Fill the radiator with clean water (Figure 81).

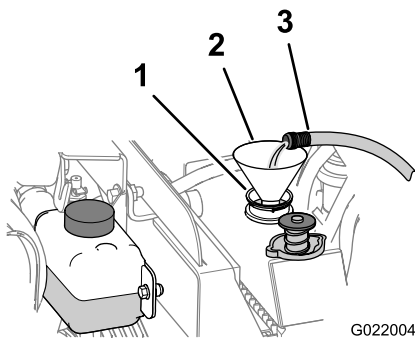

Figure 81

1. Filler neck
2. Funnel
3. Clean water

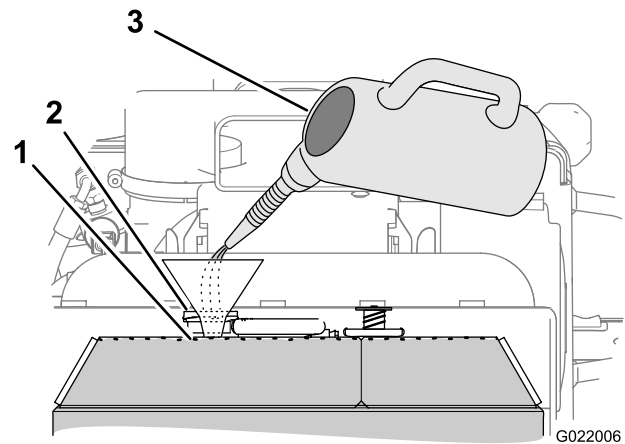

Figure 82

1. Coolant level (at the bottom of the filler neck)
2. Filler neck
3. Coolant (a mixture of 50% ethylene glycol and 50% water)

- C. Close the vent valve.
- D. Operate the engine for 5 minutes or until the coolant temperature gauge in the instrument cluster indicates 82°C (180°F), then stop the engine.

⚠ CAUTION

The water is hot and can cause burns.

Stay away from the discharge end of the coolant drain hose.

- E. Open the drain valve (Figure 78) and drain the water into a drain pan.
- F. If the water drained from the radiator is dirty, perform steps 2-A through 2-E until the water drained from the radiator is clean.
- G. Close the drain valve.

Filling the System with Coolant

Important: Fill the cooling system properly to prevent air locks in the cooling passages. Failing to vent the cooling system properly can damage it.

Note: Use a mixture of 50% ethylene glycol and 50% water in the machine. The lowest ambient operating temperature for this mixture is above -37°C (-34° F). If the ambient temperature is lower, adjust the mixture. Use a mixture of ethylene glycol and water in the machine all year.

1. Remove the radiator cap (Figure 76 and Figure 77).
2. Open the vent valve (Figure 76).
3. Fill the cooling radiator with the specified coolant mixture until the fluid level is up to the top of the filler neck (Figure 82).

Note: The coolant capacity of both the engine and the radiator is 17.2 L (18.2 US qt).

4. Close the vent valve.
5. Install the radiator cap.
6. Install the nose panel; refer to Installing the Nose Panel (page 37).
7. Fill the coolant reservoir with coolant up to the Full mark.
8. Install the coolant reservoir cap.
9. Start the engine and run it at half throttle for 5 minutes.
10. Stop the engine and remove the key.
11. Wait 30 minutes, then check the fluid level in the coolant reservoir. If it is low, add coolant.
12. Install the side panels; refer to Installing the Side Panels (page 36).

Belt Maintenance

Servicing the Engine Drive Belt

⚠ WARNING

Stop the engine and remove the ignition key before you begin to perform any maintenance or repair work.

⚠ WARNING

Contacting a rotating belt can cause serious injury or death.

Always stop the engine and remove the ignition key before working near belts.

Checking the Condition of the Belt

Service Interval: Every 250 hours

1. Remove the right-side panel; refer to Removing the Side Panels (page 35).
2. Inspect the belt for cuts, cracks, loose cords, grease, oil, twisting, or signs of abnormal wear.

Note: Replace the belt if it is excessively worn or damaged; refer to Installing the Belt (page 60).

3. Install the right-side panel; refer to Installing the Side Panels (page 36).

Checking the Tension of the Belt

Service Interval: Every 1,000 hours

1. Remove the right side panel; refer to Removing the Side Panels (page 35).
2. Place a straight edge over the drive belt and across the pulleys (Figure 83).

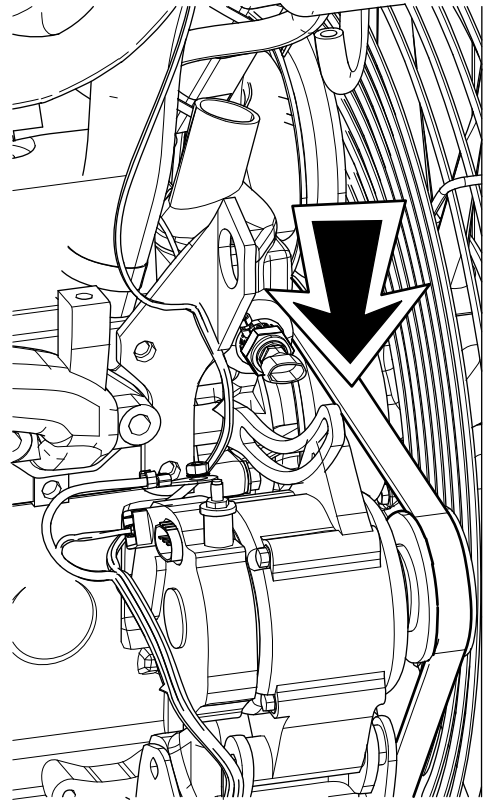

g026636

Figure 83

3. Press the belt down at the midway point between the fan pulley and the alternator pulley as shown in Figure 83.

Note: The range of belt deflection between the straight edge and the belt should be 7 to 9 mm (0.28 to 0.35 inches) under a load of 10 kg (22 lb).

4. If the tension of the belt is above or below the specified range, adjust the drive belt tension; refer to Adjusting the Tension of the Belt (page 58).
5. Install the right side panel; refer to Installing the Side Panels (page 36).

Adjusting the Tension of the Belt

1. Loosen the nut and bolt at the pivot point for the alternator (Figure 84).

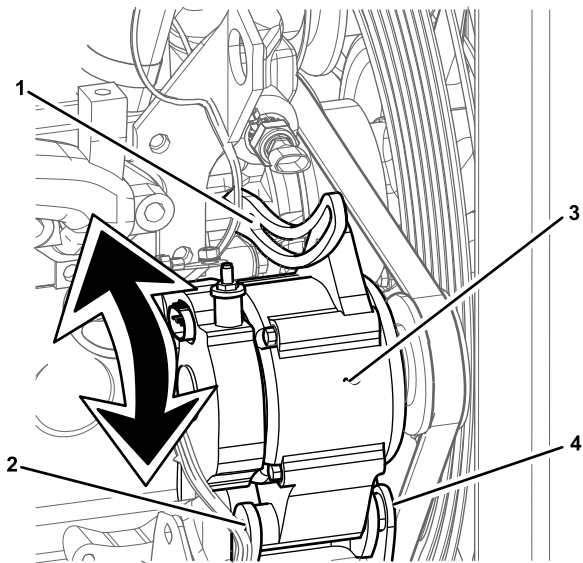

g026637

Figure 84

- | | |
|---------------------------------|----------------------------------|
| 1. Adjustment bolt | 3. Alternator |
| 2. Nut (alternator pivot point) | 4. Bolt (alternator pivot point) |

2. Loosen the adjustment bolt on the alternator (Figure 84).
3. Loosen the bolt on the mounting bracket on the engine (if necessary).
4. Move the alternator away from the engine to increase the belt tension; move the alternator toward the engine to decrease the belt tension (Figure 84).
5. Tighten the alternator adjustment bolt (Figure 84).
6. Check the tension of the belt; refer to Checking the Tension of the Belt (page 58).
7. If the belt tension is correct, tighten the nut and bolt at the pivot point for the alternator (Figure 84); otherwise repeat steps 2 through 6.
8. Switch the battery disconnect switch to the On position; refer to Battery-disconnect Switch (page 21).
9. Install the right side panel; refer to Installing the Side Panels (page 36).

Replacing the Engine Drive Belt

Removing the Belt

1. Remove the left and right side panels; refer to Removing the Side Panels (page 35).
2. Loosen the nut and bolt at the pivot point for the alternator (Figure 84).
3. Loosen the adjustment bolt on the alternator (Figure 84).

4. Loosen the engine bolt and the alternator mounting bracket.
5. Move the alternator toward the engine to loosen the belt enough so that you can remove it from the alternator pulley (Figure 84).
6. Remove the belt from the grooves of the alternator, the fan, and the crankshaft pulleys.
7. Remove the 4 bolts that secure the fan guard to the fan shroud (Figure 85).

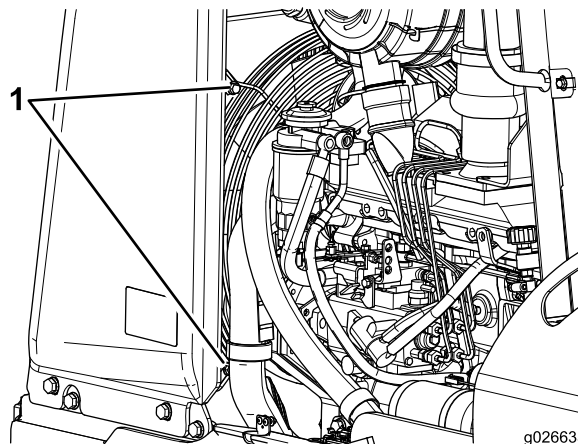

g026635

Figure 85

Left side of the machine

1. Bolts

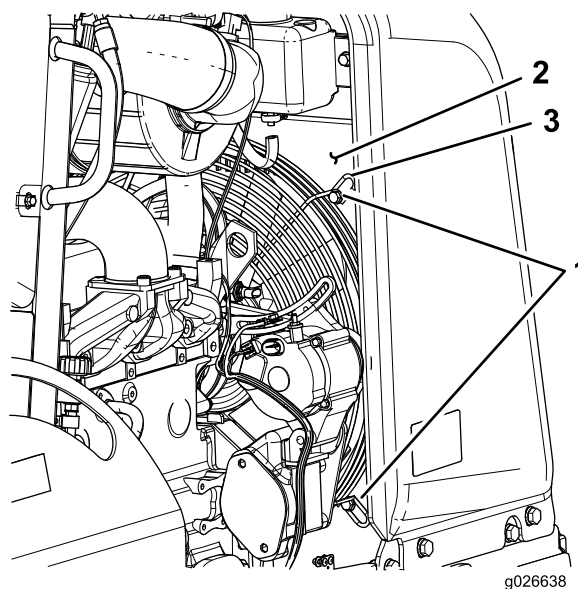

g026638

Figure 86

Right side of the machine

- | | |
|---------------|-------------------------------|
| 1. Bolts | 3. Fan guard mounting tab (4) |
| 2. Fan shroud | |

8. Rotate the fan guard counterclockwise around the drive shaft of the fan until the opening in the guard is at the 4 o'clock position.

- At the 4 o'clock position of the fan shroud, align the belt between the tip of the fan blade and the opening in the shroud (Figure 87).

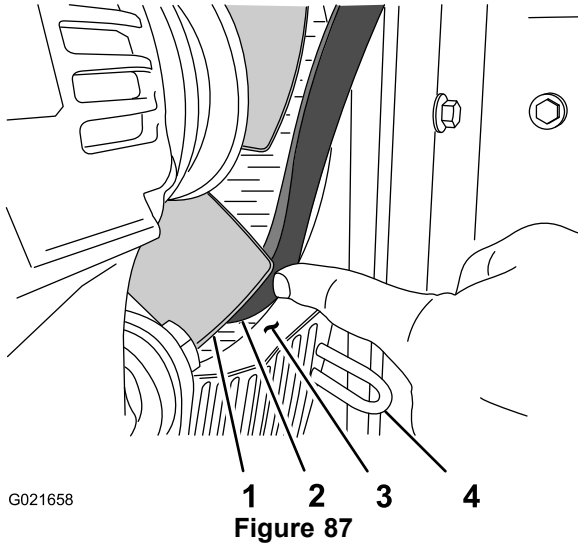

- | | |
|--------------|---------------|
| 1. Fan blade | 3. Fan shroud |
| 2. Belt | 4. Fan guard |

- Move the belt to the forward side of the fan blade.
- Rotate the fan counterclockwise and repeat steps 9 and 10 for the remaining fan blades.
- Align the belt between 2 of the fan blades, then carefully pull the belt rearward and up until you can remove it from the machine (Figure 88).

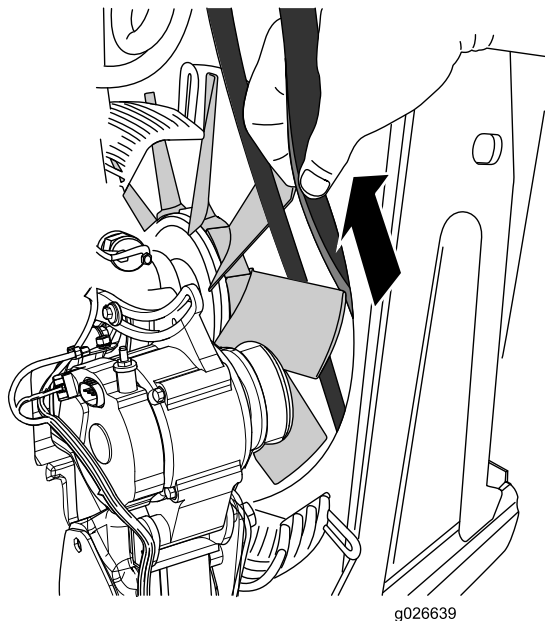

Figure 88

Installing the Belt

- Align the belt between 2 of the fan blades, and carefully push the belt forward and down until it is in front of the fan (Figure 88).
- Move a fan blade to the 4 o'clock position.
- Align the belt between the tip of the fan blade and the opening in the shroud (Figure 87).
- Move the belt rearward and past the tip of the fan blade.
- Repeat steps 2 through 4 for the remaining fan blades.
- Align the belt in the grooves of the alternator, the fan, and the crankshaft pulleys.
- Rotate the fan guard clockwise around the drive shaft of the fan until the opening in the guard is at the 6 o'clock position (Figure 85).
- Secure the fan guard to the fan shroud (Figure 85).
- Adjust the tension of the belt; refer to Adjusting the Tension of the Belt (page 58).

Note: Ensure that the belt is aligned in the grooves of the pulleys.

- Remove the drain plug from the hydraulic reservoir (located underneath the reservoir), and drain the reservoir (Figure 90).
- Note:** The capacity of the reservoir is approximately 75.7 L (20.0 US gal); the capacity of the complete system is approximately 98.4 L (26.0 US gal).
- Examine the condition of the O-ring on the drain plug.
- Note:** Replace the O-ring if it is worn or damaged.
- Install the drain plug (Figure 90).

Important: Change the hydraulic-pressure and hydraulic-return filters when you change the hydraulic fluid; refer to Changing the Hydraulic-pressure Filter (page 62) and Changing the Hydraulic-return Filter (page 63).

Filling the Hydraulic-fluid Reservoir

- Fill the hydraulic-fluid reservoir with the specified hydraulic fluid until the fluid level is at the midpoint of the sight gauge (Figure 91).

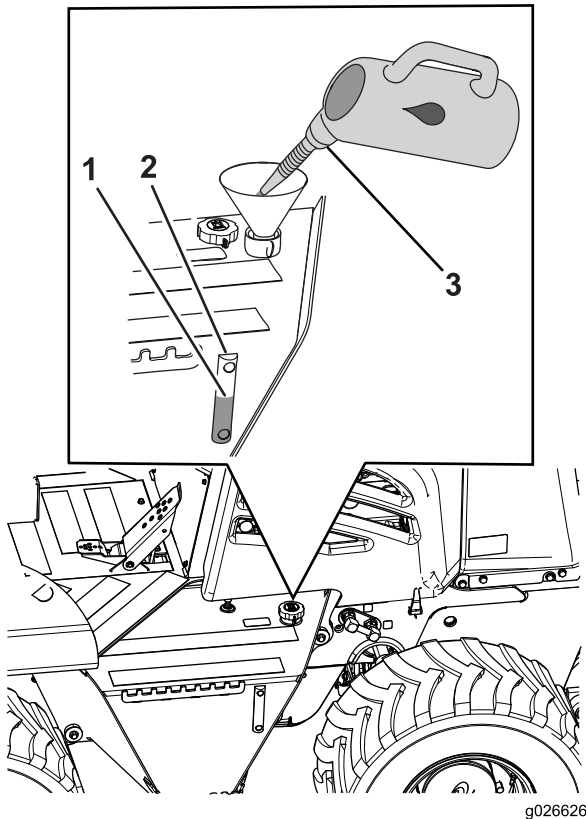

Figure 91

- Fill level (midpoint)
- Sight gauge
- Hydraulic fluid

- Remove the right-side panel; refer to Removing the Side Panels (page 35).
- Remove the breather hose, clean and inspect it, then install the hose.

- Install the right-side panel; refer to Installing the Side Panels (page 36).
- Clean the fill cap/breather with solvent.
- Install the fill cap/breather (Figure 91).
- Start the engine and let it idle for approximately 2 minutes.
- Stop the engine and remove the ignition key.
- Check around the pressure and return filters for leaks.
- Check the drain plug for leaks.
- Check the level of the hydraulic fluid and fill the reservoir to the middle of the sight glass as needed.

Changing the Hydraulic-pressure Filter

Service Interval: Every 500 hours

Note: You can access the hydraulic-pressure filter from under the right side of the machine, behind the hydraulic reservoir (Figure 92).

- Place a container under the hydraulic-pressure filter (Figure 92).

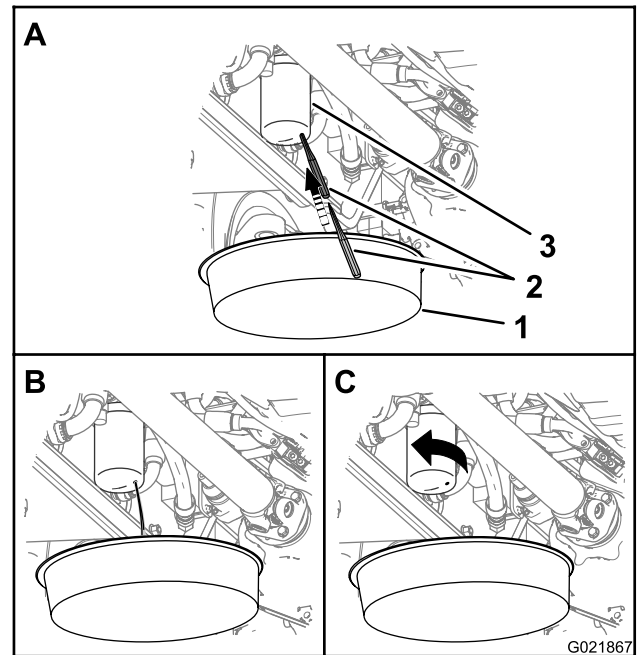

Figure 92

- Container suitable for hydraulic fluid
- Sharp object
- Hydraulic-pressure filter

- Puncture the bottom of the hydraulic-pressure filter, and allow the residual hydraulic fluid to drain into the container (Figure 92).

Note: Use a tapered-center punch or awl to puncture the filter case.

3. Rotate the hydraulic-pressure filter counterclockwise and remove the filter (Figure 92).

Note: Discard the filter.

4. Apply a thin layer of the specified hydraulic fluid to the O-ring of the new filter.

Important: Do not use a filter strap wrench to tighten the filter. A strap wrench can dent the filter, causing it to leak.

5. Install the new filter.

Note: Use your hands to tighten the filter an additional half turn after the filter makes contact with the filter head.

6. Check the level of the hydraulic fluid in the hydraulic reservoir; refer to Checking the Hydraulic Fluid Level (page 24).
7. Start the engine and let it idle for 1 or 2 minutes.
8. Stop the engine.
9. Check for leaks around the filter area.
10. Check the level of the hydraulic fluid in the hydraulic reservoir, and add fluid, if necessary.

2. Puncture the bottom of the hydraulic-pressure filter and allow the residual hydraulic fluid to drain in the container (Figure 93).

Note: Use a tapered-center punch or awl to puncture the filter case.

3. Rotate the hydraulic-return filter counterclockwise and remove the filter (Figure 93).

Note: Discard the filter properly.

4. Apply a thin layer of the specified hydraulic fluid to the O-ring of the new filter.

Important: Do not use a filter strap wrench to tighten the filter. A strap wrench can dent the filter, causing it to leak.

5. Install the new filter.

Note: Use your hands to tighten the filter an additional half turn after the filter makes contact with the filter head.

6. Check the level of the hydraulic fluid in the hydraulic reservoir; refer to Checking the Hydraulic Fluid Level (page 24).
7. Start the engine and run it at idle for 1 or 2 minutes.
8. Stop the engine and remove the key.
9. Check around the filter for leaks.
10. Check the fluid level of the hydraulic reservoir, and add fluid, if necessary.

Changing the Hydraulic-return Filter

Service Interval: Every 500 hours

Note: You can access the hydraulic-return filter from underneath the rear of the machine (Figure 93).

1. Place a container under the hydraulic-pressure filter (Figure 93).

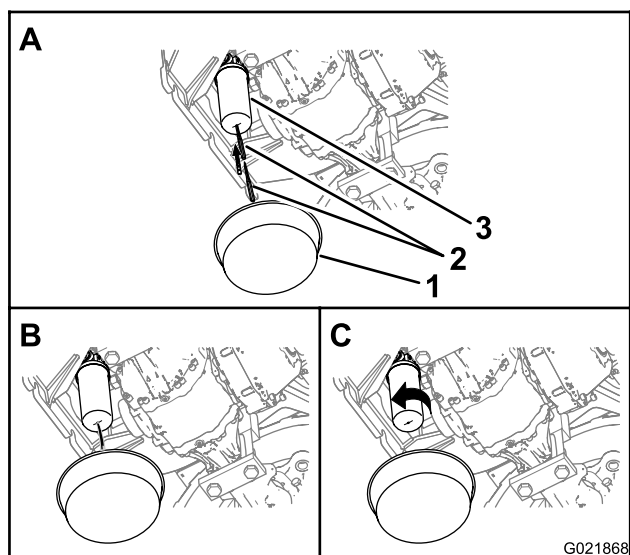

Figure 93

1. Container suitable for hydraulic fluid
2. Sharp object
3. Hydraulic return filter

ROPS Maintenance

Checking and Servicing the ROPS

Checking and Caring for the Seat Belt

Before you operate the machine, always ensure that the ROPS and the seat belt are properly installed and in good working order.

1. Check the seat belt for damage, and replace all parts that are damaged.
2. Ensure that the mounting bolts for the seat belts are tight.
3. Keep the seat belts clean using only soap and water.

Note: Do not immerse the seat belts in bleach or dye, because this weakens the belt material.

Checking and Maintaining the ROPS

Service Interval: Every 500 hours

Important: If any part of the ROPS system is damaged, replace it before you operate the machine.

1. Check that the 8 bolts that secure the ROPS bar to the chassis of the machine are torqued to 24.4 to 26.1 N-m (216 to 231 in-lb); refer to Figure 94.

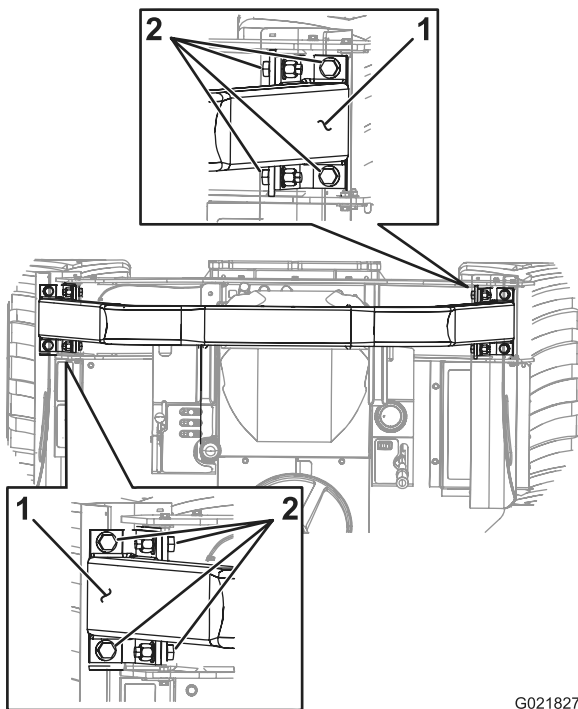

Figure 94

1. ROPS bar
2. Bolt

2. Check that the 4 bolts that secure the seat to the chassis of the machine are torqued to 5.4 to 6.8 N-m (48 to 60 in-lb); refer to Figure 95.

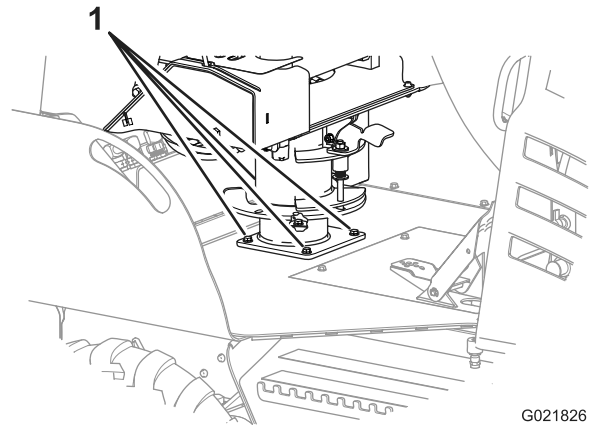

Figure 95

1. Bolt

3. Check that the bolts and nuts that attach the seat-belt retractor and buckle to the seat are torqued to 7.8 to 9.6 N-m (69 to 85 in-lb); refer to Figure 96.

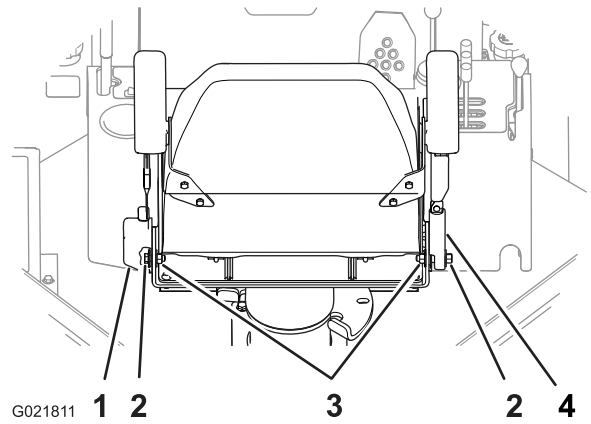

Figure 96

1. Seat-belt retractor
2. Bolt
3. Nut
4. Buckle

Note: Replace any parts that are worn or damaged.

4. Inspect the ROPS for cracks, rust, or holes in the ROPS and component parts.

Note: Age, weather, and accidents cause damage to the ROPS and ROPS parts. If you have any doubts about the ROPS system, contact an Authorized Toro Service Dealer.

Replacing a Damaged ROPS System

If the ROPS system has been damaged in an accident, such as a rollover or hitting an overhead object during transport, replace any damaged ROPS components to restore the ROPS system to its original level of protection.

After an accident, check the following items for damage:

- The ROPS bar
- Operator seat
- Seat belt mounting
- Seat belt

Before you operate the machine, replace all damaged ROPS components; contact an Authorized Toro Service Dealer.

Important: Do not try to weld or straighten a damaged ROPS bar.

Cleaning

Removing Dirt and Debris from the Machine

Important: Operating the engine with blocked screens, dirty or plugged cooling fins, and/or cooling shrouds removed, will result in engine damage from overheating.

1. Lower all attachments and set the parking brake.
2. Stop the engine, remove the key, and wait for all moving parts to stop before leaving the operating position.
3. Wipe away dirt and debris from the air cleaner.
4. Clean any dirt and debris buildup on the engine with a brush or blower.

Important: It is preferable to blow dirt out, rather than washing it out. If water is used, keep it away from electrical items and hydraulic valves. Do not use a high-pressure washer. High-pressure washing can damage the electrical system and hydraulic valves or deplete grease.

Storage

Preparing for Seasonal Storage

For storage over 30 days, prepare the machine, the attachments, and the engine as follows:

Preparing the Machine and Attachments

1. Thoroughly clean the machine and all the attachments; refer to Removing Dirt and Debris from the Machine (page 65).
2. Lower all the attachments and set the parking brake.
3. Stop the engine, remove the key, and wait for all moving parts to stop before leaving the operating position.
4. Check the tire pressure and adjust it, if necessary; refer to Maintaining the Air Pressure in the Tires (page 48).
5. Check all fasteners and tighten them as necessary.
6. Grease all fittings and pivot points and wipe up any excess grease; refer to Greasing the Machine (page 33).
7. Repair any dents in the machine or the attachments, and lightly sand and paint areas that are bare, scratched, chipped, or rusted. Paint is available from an Authorized Toro Service Dealer.
8. Service the battery and the cables as follows:
 - A. Remove the battery terminals from the battery posts.
 - B. Clean the battery, terminals, and posts with a wire brush and baking soda solution.
 - C. Coat the cable terminals and battery posts with Grafo 112X skin-over grease (Toro Part No. 505-47) or equivalent grease.
 - D. Slowly recharge the battery every 60 days for 24 hours to prevent lead sulfation of the battery.
9. Check and tighten all bolts, nuts, and screws. Repair or replace any part that is damaged.
10. Store the machine in a clean, dry garage or storage area. Remove the key from the ignition switch and keep it in a memorable place.
11. Cover the machine to protect it and keep it clean.

Preparing the Engine

1. Remove dirt and grime from the external parts of the engine. Clean dirt and chaff from the outside of the engine cylinder-head fins and blower housing.
2. Change the engine oil and the oil filter; refer to Changing the Engine Oil (page 38).

3. Start the engine and run it at idle speed for approximately 2 minutes.
4. Stop the engine.
5. Flush the fuel tank with fresh, clean diesel fuel.
6. Secure all the fuel system fittings.
7. Service the air cleaner; refer to Servicing the Air-cleaner System (page 39).
8. Seal the air cleaner inlet and the exhaust outlet with plastic and weatherproof tape.
9. Check the anti freeze protection and add a 50% ethylene glycol and 50% water solution of anti-freeze as needed for the expected minimum temperature in your area.

Troubleshooting

Problem	Possible Cause	Corrective Action
The starter does not crank.	<ol style="list-style-type: none"> 1. The electrical connections are corroded or loose. 2. A fuse is blown. 3. A fuse is loose. 4. The battery is discharged. 5. The relay or switch is damaged. 6. The starter or starter solenoid is damaged. 7. Internal engine components have seized up. 	<ol style="list-style-type: none"> 1. Check the electrical connections for good contact. 2. Replace the fuse. 3. Install the fuse. 4. Charge the battery or replace it. 5. Contact your Authorized Service Dealer. 6. Contact your Authorized Service Dealer. 7. Contact your Authorized Service Dealer.
1. The engine cranks but will not start.	<ol style="list-style-type: none"> 1. The starting procedure is incorrect. 2. The fuel tank is empty. 3. The fuel shutoff valve is closed. 4. There is dirt, water, stale fuel, or incorrect fuel in the fuel system. 5. The fuel line is clogged. 6. There is air in the fuel. 7. The glow plugs do not operate. 8. The cranking speed is slow. 9. The air cleaning system elements are dirty. 10. The fuel filter is clogged. 11. The fuel is not the proper grade for cold-weather use. 12. The engine has low compression. 13. The injection nozzles or pump are malfunctioning. 	<ol style="list-style-type: none"> 1. Refer to Starting the Engine in Operation. 2. Fill the fuel tank with fresh fuel. 3. Open the fuel shutoff valve. 4. Drain and flush the fuel system; add fresh fuel. 5. Clean or replace the fuel line. 6. Bleed the nozzles and check for air leaks at the fuel hose connections and fittings between the fuel tank and engine. 7. Check the fuse, glow plugs, and wiring. 8. Check the battery, oil viscosity, and starting motor (contact your Authorized Service Dealer). 9. Service the air cleaning system elements. 10. Replace the fuel filter. 11. Drain the fuel system, replace the fuel filter, and add fresh fuel having the proper grade for ambient temperature conditions. You may need to warm up the entire machine. 12. Contact your Authorized Service Dealer. 13. Contact your Authorized Service Dealer.
The engine starts but does not keep running.	<ol style="list-style-type: none"> 1. The fuel tank vent is restricted. 2. There is dirt or water in the fuel system. 3. The fuel filter is clogged. 4. There is air in the fuel. 5. The fuel is not the proper grade for cold-weather use. 6. The fuel pump is damaged. 	<ol style="list-style-type: none"> 1. Loosen the cap. If the engine runs with the cap loosened, replace the cap. 2. Drain and flush the fuel system; add fresh fuel. 3. Replace the fuel filter. 4. Bleed the nozzles and check for air leaks at fuel hose connections and fittings between the fuel tank and the engine. 5. Drain the fuel system, replace the fuel filter, and add fresh fuel having the proper grade for ambient temperature conditions. You may need to warm up the entire machine. 6. Contact your Authorized Service Dealer.

Problem	Possible Cause	Corrective Action
The engine runs but knocks or misses.	<ol style="list-style-type: none"> 1. There is dirt or water in the fuel system. 2. The engine overheats. 3. There is air in the fuel. 4. The injection nozzles are damaged. 5. The engine has low compression. 6. The injection pump timing is incorrect. 7. There is excessive carbon buildup. 8. The engine has internal wear or damage. 	<ol style="list-style-type: none"> 1. Drain and flush the fuel system; add fresh fuel. 2. Check the engine oil level and add oil as needed; also check and service the coolant system, if necessary. 3. Bleed the nozzle and check for air leaks at the fuel hose connections and the fittings between the fuel tank and the engine. 4. Contact your Authorized Service Dealer. 5. Contact your Authorized Service Dealer. 6. Contact your Authorized Service Dealer. 7. Contact your Authorized Service Dealer. 8. Contact your Authorized Service Dealer.
The engine is overheated.	<ol style="list-style-type: none"> 1. The coolant level is too low. 2. The air flow to the radiator is restricted. 3. The engine oil level is either too low or too high. 4. The machine is under an excessive load. 5. There is improper fuel in the fuel system. 6. The thermostat is damaged. 7. The fan belt is loose or broken. 8. The injection timing is incorrect. 9. The coolant pump is damaged. 	<ol style="list-style-type: none"> 1. Check the coolant level and add coolant to the system. 2. Inspect and clean the radiator screen. 3. Either add or drain the engine oil until the oil level is at the Full mark. 4. Reduce the load on the machine; operate the machine at a slower ground speed. 5. Drain and flush the fuel system, then add fresh fuel. 6. Contact your Authorized Service Dealer. 7. Contact your Authorized Service Dealer. 8. Contact your Authorized Service Dealer. 9. Contact your Authorized Service Dealer.
There is excessive black smoke in the exhaust.	<ol style="list-style-type: none"> 1. The engine is under an excessive load. 2. The air cleaning system elements are dirty. 3. There is improper fuel in the fuel system. 4. The injection pump timing is incorrect. 5. The injection pump is damaged. 6. The injection nozzles are damaged. 	<ol style="list-style-type: none"> 1. Reduce the ground speed of the machine. 2. Service the air cleaning system elements. 3. Drain and flush the fuel system, then add fresh fuel. 4. Contact your Authorized Service Dealer. 5. Contact your Authorized Service Dealer. 6. Contact your Authorized Service Dealer.

Problem	Possible Cause	Corrective Action
There is excessive white smoke in the exhaust.	<ol style="list-style-type: none"> 1. The key was turned to the Start position before the glow plug light turned off. 2. The engine temperature is low. 3. The glow plugs are not operating. 4. The injection pump timing is incorrect. 5. The injection nozzles are damaged. 6. The engine has low compression. 	<ol style="list-style-type: none"> 1. Turn the key to the Run position and allow the glow plug light to turn off before starting the engine. 2. Check the thermostat and replace it if necessary. 3. Check the fuse, glow plugs, and wiring. 4. Contact your Authorized Service Dealer. 5. Contact your Authorized Service Dealer. 6. Contact your Authorized Service Dealer.
The engine loses power.	<ol style="list-style-type: none"> 1. The engine is under an excessive load. 2. The engine oil level is either too low or too high. 3. The air cleaning system elements are dirty. 4. There is dirt or water in the fuel system. 5. The engine overheats. 6. There is air in the fuel. 7. The engine has low compression. 8. The fuel tank vent is restricted. 9. The injection pump timing is incorrect. 10. The injection pump is damaged. 	<ol style="list-style-type: none"> 1. Reduce the ground speed of the machine. 2. Either add or drain the engine oil until the oil level is at the Full mark. 3. Service the air cleaning system elements. 4. Drain and flush the fuel system; add fresh fuel. 5. Check the engine oil level and add oil as needed; also check and service the coolant system, if necessary. 6. Bleed the nozzle and check for air leaks at the fuel hose connections and the fittings between the fuel tank and the engine. 7. Contact your Authorized Service Dealer. 8. Loosen the cap. If the engine runs with the cap loosened, replace the cap. 9. Contact your Authorized Service Dealer. 10. Contact your Authorized Service Dealer.
The machine does not drive.	<ol style="list-style-type: none"> 1. The parking brake is engaged. 2. The hydraulic fluid level is low. 3. The tow valves are open. 4. The pump and/or motor is damaged. 5. The relief valve is damaged. 	<ol style="list-style-type: none"> 1. Release the parking brake. 2. Add hydraulic fluid to the reservoir. 3. Close the tow valves. 4. Contact your Authorized Service Dealer. 5. Contact your Authorized Service Dealer.

Notes:

Notes:



The Toro Underground Warranty

Underground
Equipment

A Limited Warranty

Conditions and Products Covered

The Toro Company and its affiliate, Toro Warranty Company, pursuant to an agreement between them, jointly warrant your Toro Underground Equipment ("Product") to be free from defects in materials or workmanship. Where a warrantable condition exists, we will repair the Product at no cost to you including diagnostics, labor, and parts. The following warranty applies from the date the Product is delivered to the original retail purchaser or rental owner.

Products	Warranty Period
RT600, RT1200, DD2024, and DD4045	2 years or 1500 operating hours, whichever occurs first
All Other Engine Powered Base Units and Fluid Mixers	1 year or 1000 operating hours, whichever occurs first
All Serialized Attachments	1 year
Rock Hammer	6 months
Engines	Through engine manufacturers: 2 years or 2000 operating hours, whichever occurs first

Instructions for Obtaining Warranty Service

You are responsible for notifying the Underground Dealer from whom you purchased the Product as soon as you believe a warrantable condition exists. If you need help locating a Underground Dealer, or if you have questions regarding your warranty rights or responsibilities, you may contact us at:

Toro Customer Care
Toro Warranty Company
8111 Lyndale Avenue South
Bloomington, MN 55420-1196
Toll Free at 855-493-0088 (U.S. Customers)
1-952-948-4318 (International Customers)

Owner Responsibilities

As the Product owner, you are responsible for required maintenance and adjustments stated in your *Operator's Manual*. Failure to perform required maintenance and adjustments can be grounds for disallowing a warranty claim.

Items and Conditions Not Covered

Not all product failures or malfunctions that occur during the warranty period are defects in materials or workmanship. This warranty does not cover the following:

- Product failures which result from the use of non-Toro replacement parts, or from installation and use of add-on, or modified non-Toro branded accessories and products. A separate warranty may be provided by the manufacturer of these items.
- Product failures which result from failure to perform recommended maintenance and/or adjustments. Failure to properly maintain your Toro product per the Recommended Maintenance listed in the *Operator's Manual* can result in claims for warranty being denied.
- Product failures which result from operating the Product in an abusive, negligent, or reckless manner.
- Parts subject to consumption through use unless found to be defective. Examples of parts which are consumed, or used up, during normal Product operation include, but are not limited to: brakes, filters, lights,

bulbs, belts, tracks or tires, digging teeth, digging booms, digging, drive, or track chains, track pads, drive sprockets, idlers, rollers, blades, cutting edges, or other ground engaging components.

- Failures caused by outside influence. Conditions considered to be outside influence include, but are not limited to, weather, storage practices, contamination, use of unapproved fuels, coolants, lubricants, additives, water, or chemicals, etc.
- Failure or performance issues due to the use of fuels (e.g. gasoline, diesel, or biodiesel) that do not conform to their respective industry standards.
- Normal noise, vibration, wear and tear, and deterioration.
- Normal "wear and tear" includes, but is not limited to, damage to seats due to wear or abrasion, worn painted surfaces, scratched decals, etc.
- Hauling expenses, travel time, mileage, or overtime associated with transporting product to the authorized Toro dealer.

Parts

Parts scheduled for replacement as required maintenance in the *Operator's Manual*, are warranted for the period of time up to the scheduled replacement time for that part. Parts replaced under this warranty are covered for the duration of the original product warranty and become the property of Toro. Toro will make the final decision whether to repair any existing part or assembly or replace it. Toro may use remanufactured parts for warranty repairs.

Maintenance is at Owner's Expense

Engine tune-up, lubrication, cleaning and polishing, replacement of filters, coolant, and completing recommended maintenance are some of the normal services Toro products require that are at the owner's expense.

General Conditions

Repair by an Authorized Toro Underground Dealer is your sole remedy under this warranty.

Neither The Toro Company nor Toro Warranty Company is liable for indirect, incidental or consequential damages in connection with the use of the Toro Products covered by this warranty, including any cost or expense of providing substitute equipment or service during reasonable periods of malfunction or non-use pending completion of repairs under this warranty. Except for the Emissions warranty referenced below, if applicable, there is no other express warranty. All implied warranties of merchantability and fitness for use are limited to the duration of this express warranty.

Some states do not allow exclusions of incidental or consequential damages, or limitations on how long an implied warranty lasts, so the above exclusions and limitations may not apply to you. This warranty gives you specific legal rights, and you may also have other rights which vary from state to state.

Note regarding engine warranty:

The Emissions Control System on your Product may be covered by a separate warranty meeting requirements established by the U.S. Environmental Protection Agency (EPA) and/or the California Air Resources Board (CARB). The hour limitations set forth above do not apply to the Emissions Control System Warranty. Refer to the Engine Emission Control Warranty Statement supplied with your product or contained in the engine manufacturer's documentation for details.

Countries Other than the United States or Canada

Customers who have purchased Toro products exported from the United States or Canada should contact their Toro Distributor (Dealer) to obtain guarantee policies for your country, province, or state. If for any reason you are dissatisfied with your Underground Dealer's service or have difficulty obtaining guarantee information, contact the Toro importer.

Australian Consumer Law: Australian customers will find details relating to the Australian Consumer Law either inside the box or at your local Toro Dealer.