



Count on it.

Parts Catalog

**TITAN® MX5400 Zero-Turn-Radius
Riding Mower**

Model No. 74882—Serial No. 314000001 and Up



Ordering Replacement Parts

To order replacement parts, please supply the part number, the quantity, and the description of each part desired.

Understanding Reference Numbers

Each identified part in an illustration has a reference number. The reference number for a part also appears in the parts list, along with other information about the part.

This catalog uses two special reference number formats, one to indicate parts in a service assembly and another to indicate the quantity of a given part in an illustration.

Service Assembly Reference Numbers

Parts in service assemblies have reference numbers in the form a:b. The a represents the reference number of the entire service assembly and the b represents a sequential number unique to each part within the service assembly.

For example, a wheel assembly might be identified by reference number 6, the tire by 6:1, the valve by 6:2, and the wheel by 6:3. When you order the assembly identified by reference number 6, you receive all parts identified by reference numbers 6:1, 6:2, and 6:3. However, you may also order any part individually. Reference numbers of this type appear in illustration and in parts lists.

Reference Numbers Indicating Quantity

In an illustration, if a reference number indicates more than one part, the reference number has the form nX y. The n represents the quantity of the part, the X is the multiplication symbol, and the y represents the reference number.

For example, in an illustration, the reference number 2X 37 means that two of the parts identified by reference number 37 are indicated.

List of Abbreviations

AR: as required

ASM: assembly

BBC: blade brake control

BHTF: button head thread forming

CARR: carriage

CCW: counter clockwise

CW: clockwise

DEG: degrees

DPA: Dual Point Adjustment

ECM: electronic control module

EXT: external

FH: flat head

GA: gauge

HD: heavy-duty

HF: hex flange

HH: hex head

HHF: hex head flange

HHFTF: hex head flange thread forming

HJ: hex jam

HLH: hex lag head

HOC: height-of-cut

HP: high pressure

HSBH: hex socket button head

HSFH: hex socket flat head

HSH: hex socket head

HWH: hex washer head

HWHTF: hex washer head thread forming

HYD: hydraulic

LH: left hand

LP: low pressure

LPG: Liquefied Petroleum Gas

NI: nylon insert

NPTF: national pipe thread fine

PFH: phillips flat head

PPH: phillips pan head

PPHTF: phillips pan head thread forming

PRH: phillips round head

PTH: phillips truss head

PTO: power-take-off

RH: right hand

ROPS: roll-over protection system

RRB: rear roller brush

SFH: slotted fillister head

SHH: slotted hex head

SHWH: slotted hex washer head

SPH: slotted pan head

SQH: square head

SRH: slotted round head

STD: standard

TAP: self tapping

TTH: torx truss head

Contents

Frame, Front Axle and Caster Wheel Assembly	4
Wheel and Tire Assembly No. 125-5580	6
Control Panel and Body Styling Pod Assembly	8
Deck Lift Assembly	10
Traction Drive Assembly	12
LH Hydro Transmission Assembly No. 127-3381	14
RH Hydro Transmission Assembly No. 127-3382	16
Motion Control Assembly	18
Brake Link Assembly	20
Engine, Muffler and Clutch Assembly	22
Fuel Delivery Assembly	24
Multi Layer Fuel Tank Assembly No. 117-7352	26
Roll-Over Protection System Assembly	28
Electrical Assembly	30
Seat Assembly	32
Seat Assembly No. 130-0801	34
54 Inch Deck Assembly	36
54 Inch Deck, Belt and Mulch Blade Assembly	38
54 Inch Deck and Decal Assembly	40
Attachments and Accessories	42

Frame, Front Axle and Caster Wheel Assembly

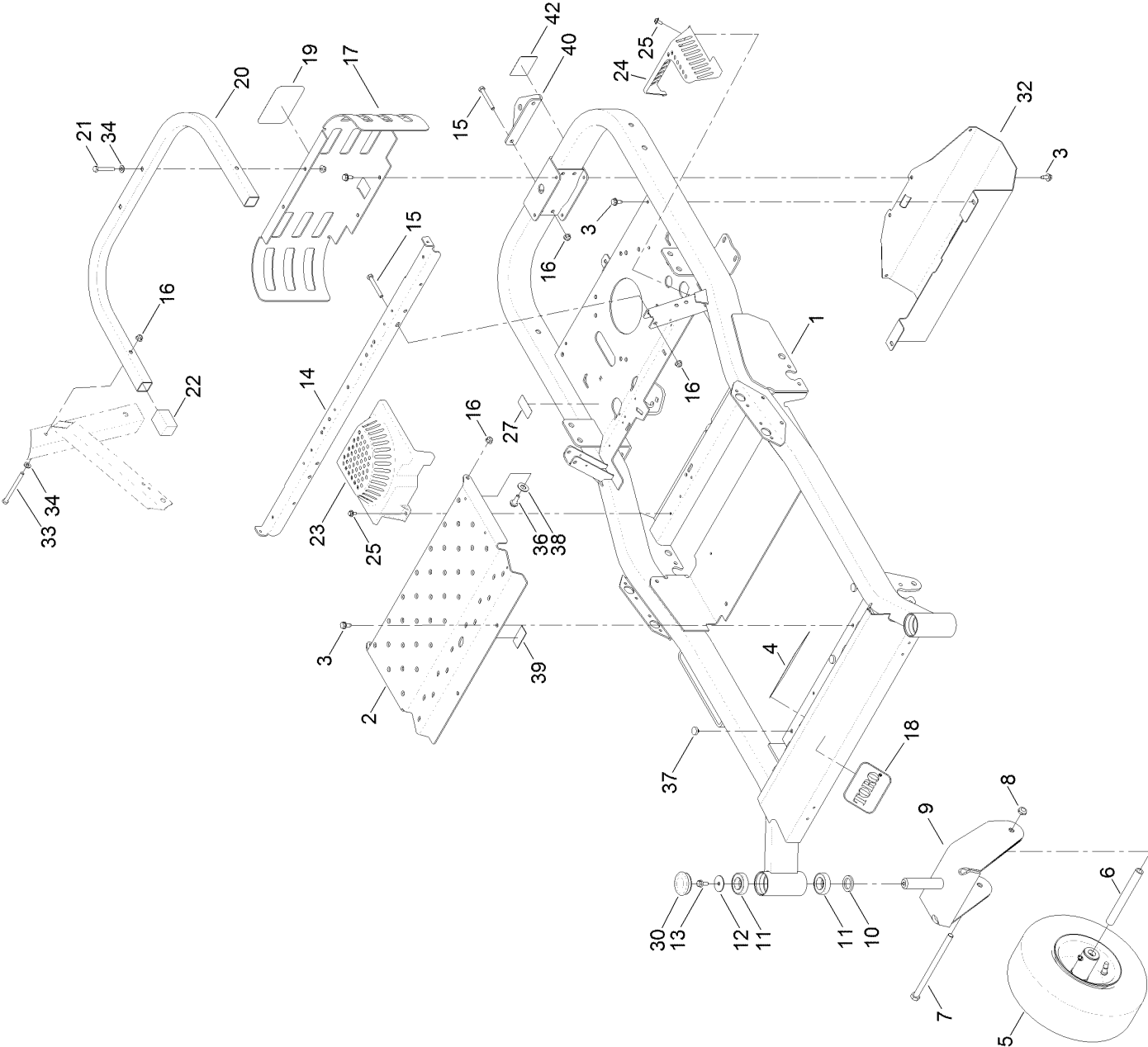

Frame, Front Axle and Caster Wheel Assembly (continued)

<i>Ref.</i>	<i>Part Number</i>	<i>Qty.</i>	<i>Description</i>	<i>Ref.</i>	<i>Part Number</i>	<i>Qty.</i>	<i>Description</i>
1	127-0067-01	1	Frame	19	105-8278	1	Decal
2	127-3423-01	1	Pan-Floor	20	121-0704-01	1	Tube-Guard
3	32144-70	6	Screw-HWHTF	21	322-10	2	Screw-HH
4	130-6921	1	Decal-Danger	22	121-2980	2	Cap
5	125-5580	2	Tire And Wheel ASM	23	117-1241	1	Cover-Fan, RH
6	127-0068	2	Spanner - Wheel, Caster	24	117-1242	1	Cover-Fan, LH
7	325-42	2	Screw-HH	25	46-8560	2	Screw-HHFTF
8	3296-45	2	Nut-Lock, NI	27	127-6033	1	Decal-Emissions
9	127-0058-01	2	Caster Fork ASM	30	116-4348	2	Cap-Grease
10	117-7394	2	Washer-Thrust	32	120-2247-03	1	Guard-Muffler
11	109-3678	4	Bearing-Ball	33	322-23	2	Screw-HH
12	3256-68	2	Washer-Flat	34	3256-23	4	Washer-Flat
13	3234-47	2	Screw-HHF	36	116-1297	2	Screw-Shoulder
14	121-2953-03	1	Support-Seat	37	1-513658	3	Bumper
15	322-12	4	Screw-HH	38	112-9771	1	Washer-Teflon
16	104-8300	10	Nut-Flange, NI	39	130-0733	3	Pad-Rubber
17	120-2248-03	1	Guard-Rear	40	117-1232-03	1	Bracket-Hitch
18	67-1300	1	Decal	42	109-7076	1	Decal

Wheel and Tire Assembly No. 125-5580

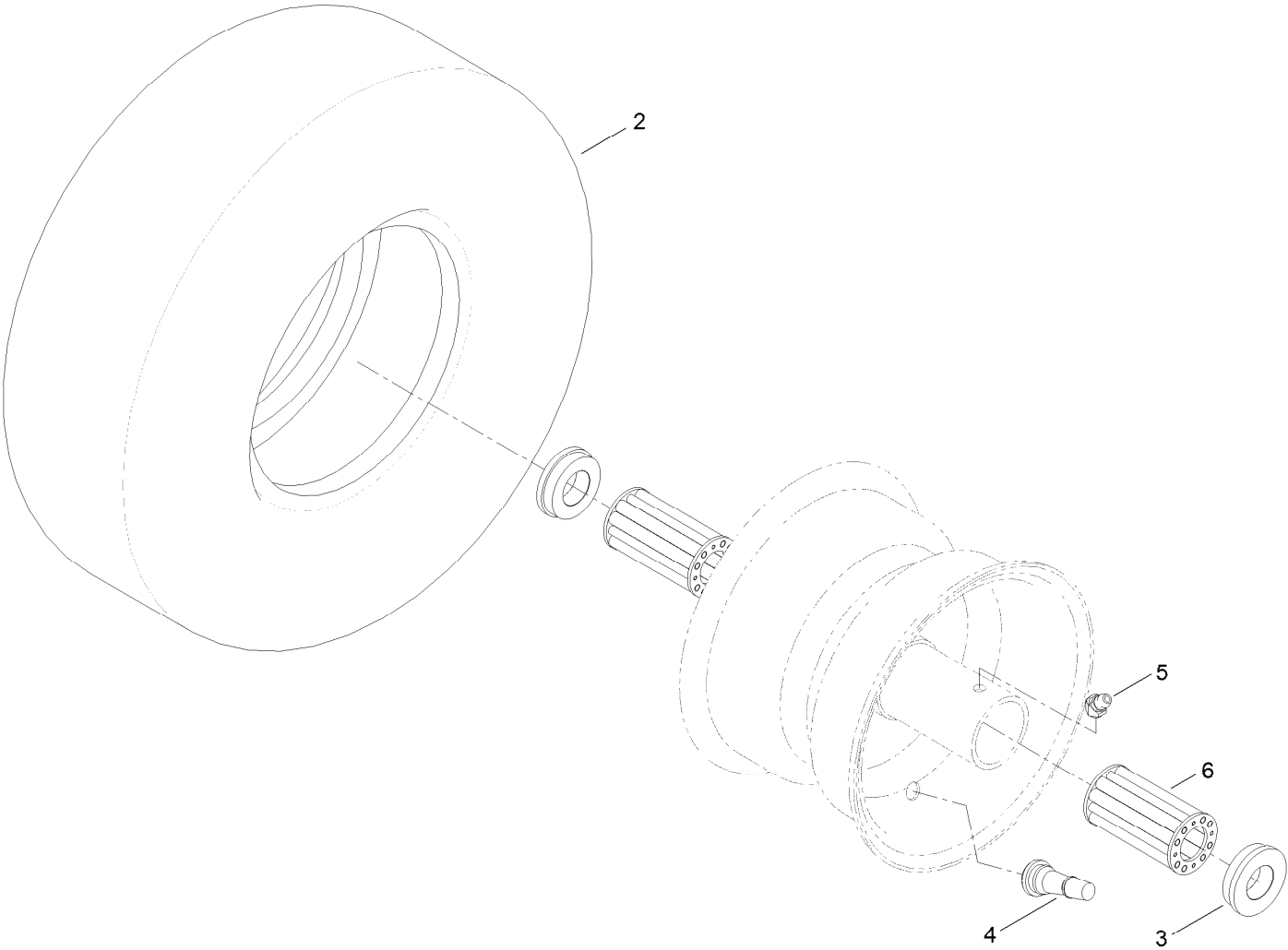

Wheel and Tire Assembly No. 125-5580 (continued)

<i>Ref.</i>	<i>Part Number</i>	<i>Qty.</i>	<i>Description</i>	<i>Ref.</i>	<i>Part Number</i>	<i>Qty.</i>	<i>Description</i>
2	125-5581	1	Tire	5	120-7125	1	Fitting-Zerk
3	130-0705	2	Bushing-Flange	6	83-4740	2	Bearing
4	5108	1	Valve	99	232-46	1	Tube ●

● Not illustrated

Control Panel and Body Styling Pod Assembly

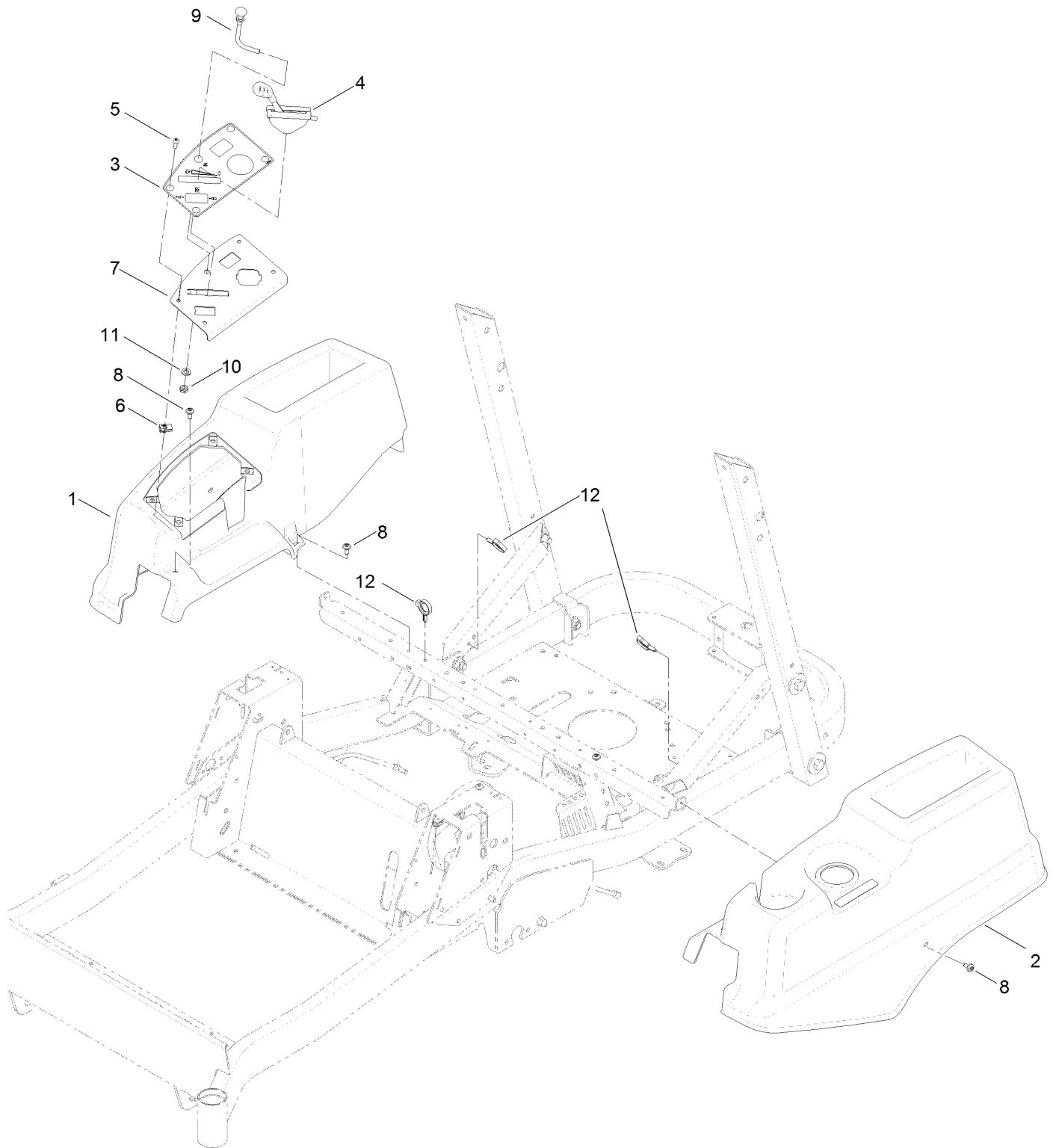

Control Panel and Body Styling Pod Assembly (continued)

<i>Ref.</i>	<i>Part Number</i>	<i>Qty.</i>	<i>Description</i>	<i>Ref.</i>	<i>Part Number</i>	<i>Qty.</i>	<i>Description</i>
1	120-5488	1	Pod-RH	7	115-2591-03	1	Panel-Control
2	120-5489	1	Pod-LH	8	120-7950	6	Screw-Shoulder
3	115-9632	1	Decal-Panel, Control	9	120-2291	1	Cable-Choke
4	121-0770	1	Cable-Throttle	10	3253-21	1	Washer-Lock
5	3258-166	4	Screw-PRH	11	3220-3	1	Nut-HJ
6	107069	4	Clip	12	105-1853	2	Clamp-Hose

Deck Lift Assembly

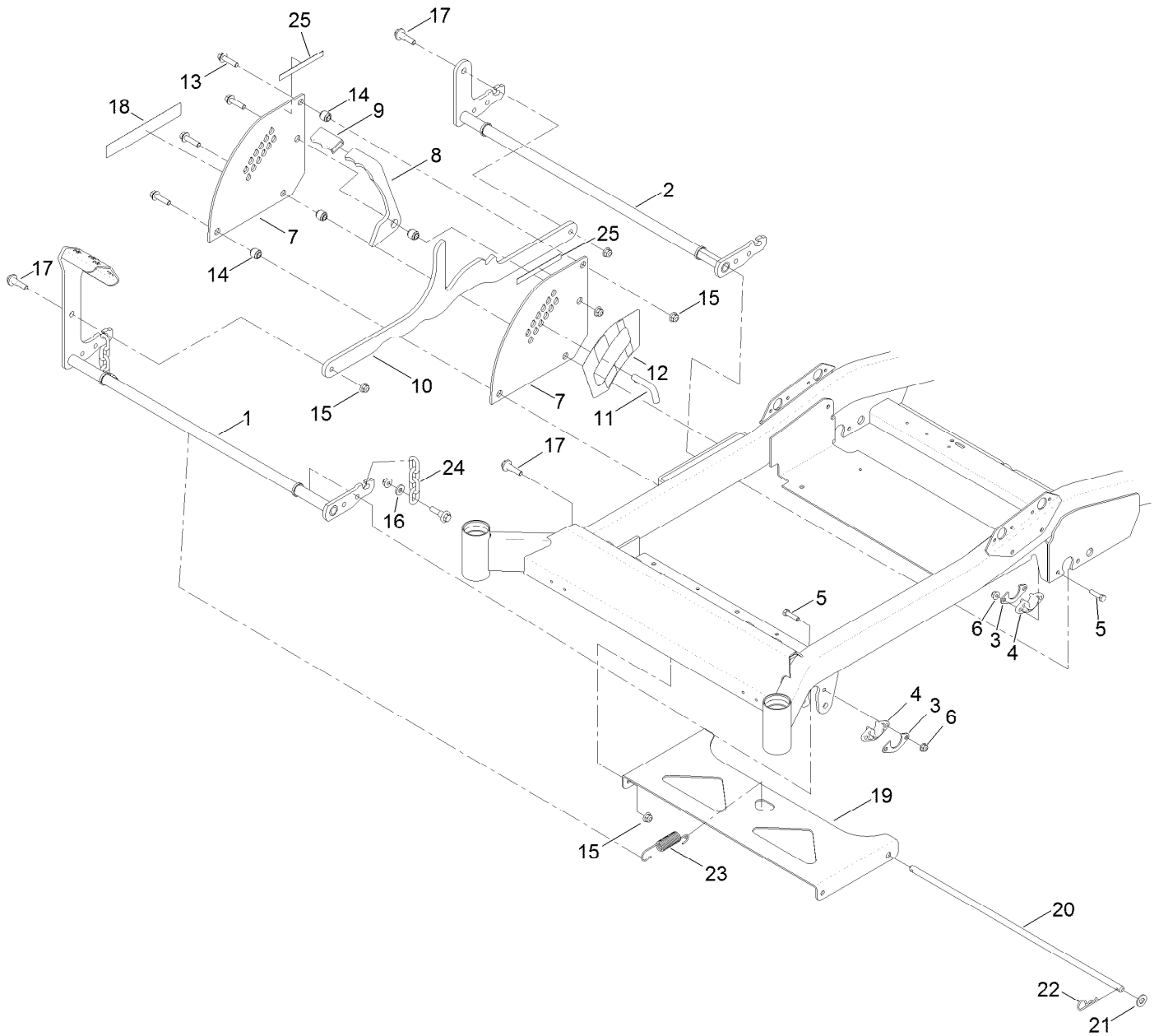

Deck Lift Assembly (continued)

<i>Ref.</i>	<i>Part Number</i>	<i>Qty.</i>	<i>Description</i>	<i>Ref.</i>	<i>Part Number</i>	<i>Qty.</i>	<i>Description</i>
1	130-0657-03	1	Pivot-Front	14	116-4313	4	Spacer-Step, Double
2	130-0658-03	1	Pivot-Rear	15	104-8301	10	Nut-Flange, NI
3	116-2887	4	Gusset-Lift, Deck	16	43-0940	4	Spacer
4	115-5065	4	Bushing-Flange	17	130-0742	8	Bolt-Shoulder
5	322-6	8	Screw-HH	18	130-0786	1	Decal-Mx Series
6	104-8300	8	Nut-Flange, NI	19	127-3329-01	1	Pan-Deck, Pivot
7	127-3389-03	2	Plate-Deck, Lift	20	127-3399	1	Rod-Deck, Pivot
8	127-3391	1	Lock-Transport, HOC	21	3256-26	2	Washer-Flat
9	116-4312	1	Grip-Bar, Flat	22	1-806005	2	Pin-Hair
10	127-3390-03	1	Link-HOC	23	115-9652	1	Spring-Extension
11	116-5584	1	Pin-HOC	24	130-0668	4	Chain-Decklift
12	130-0654	1	Decal-HOC	25	130-0734	2	Pad-Rubber
13	114-4681	4	Screw-HHF				

Traction Drive Assembly

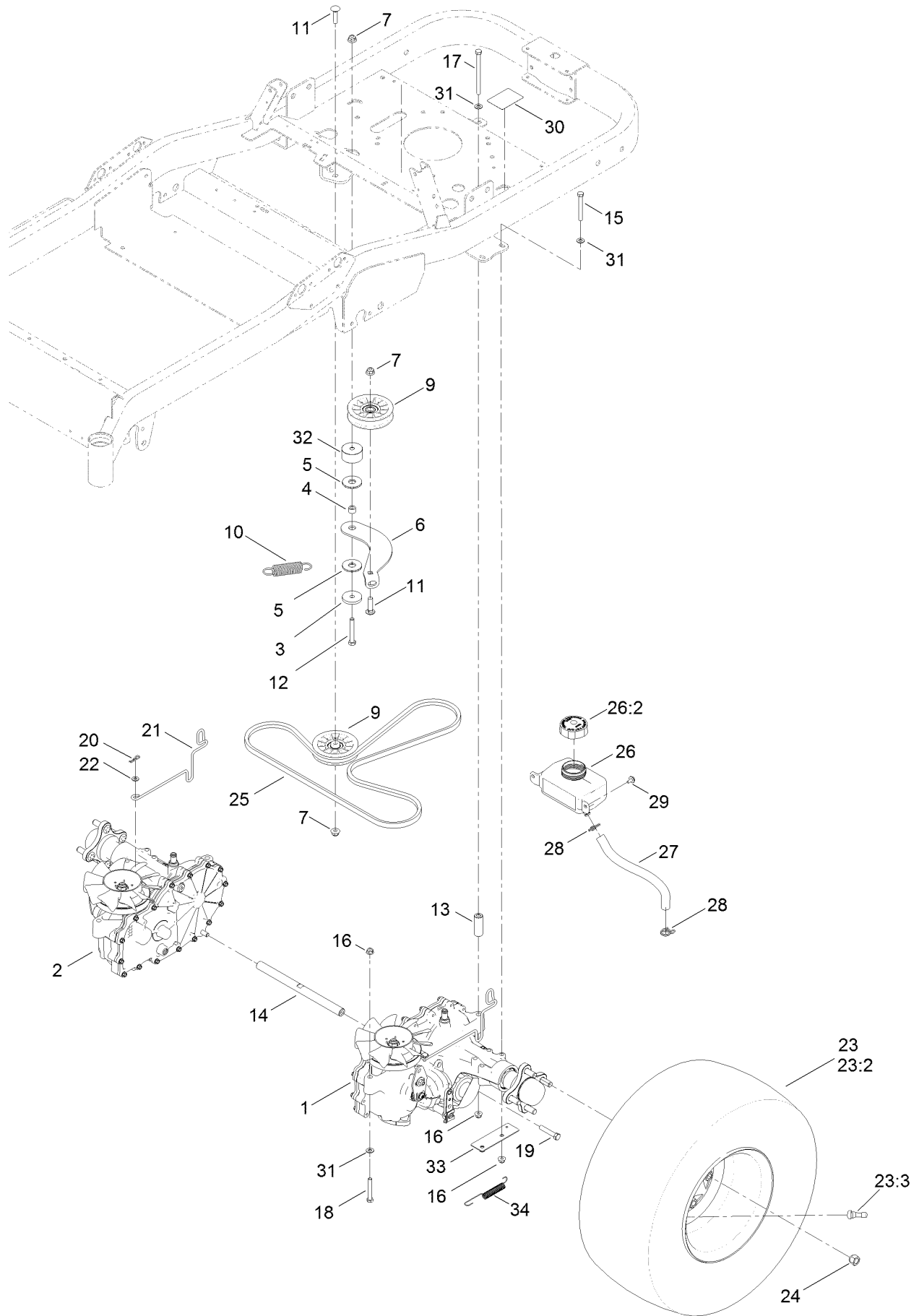

Traction Drive Assembly (continued)

<i>Ref.</i>	<i>Part Number</i>	<i>Qty.</i>	<i>Description</i>	<i>Ref.</i>	<i>Part Number</i>	<i>Qty.</i>	<i>Description</i>
1	127-3381	1	LH Hydro Transmission ASM	20	1-806003	2	Pin-Cotter, Hair
2	127-3382	1	RH Hydro Transmission ASM	21	125-8950	2	Rod-Bypass
3	110-9981	1	Washer-Plain	22	3256-22	2	Washer-Flat
4	115-4986	1	Spacer	23	130-0791	2	Tire And Wheel ASM
5	114-0463	2	Washer-Friction, Composite	23:2	130-0792	1	Tire
6	117-5350	1	Arm-Idler	23:3	232-27	1	Stem-Valve
7	104-8301	3	Nut-Flange, NI	23:99	131-0933	1	Tube-Inner ●
9	109-3397	2	Pulley-Idler, Flat	24	242-50	8	Nut-Lug
10	1-603402	1	Spring-Extension	25	115-9613	1	V-Belt
11	3231-26	2	Screw-CARR	26	115-9618	1	HYD Reservoir ASM
12	323-12	1	Screw-HH	26:2	109-3320	1	Cap-Reservoir, HYD
13	109-3652	2	Spacer-Hydro	27	115-4969	2	Hose-Overflow
14	115-2559	1	Shaft-Cross, Hydro	28	117-1193	4	Clamp-Hose
15	322-13	4	Screw-HH	29	46-8560	2	Screw-HHFTF
16	104-8300	8	Nut-Flange, NI	30	130-6922	2	Decal-Bypass
17	322-38	2	Screw-HH	31	3256-23	8	Washer-Flat
18	322-11	2	Screw-HH	32	117-5351	1	Spacer
19	323-10	2	Screw-HH	33	117-7248-03	2	Plate-Spring
				34	110769	2	Spring-Extension

● Not illustrated

LH Hydro Transmission Assembly No. 127-3381

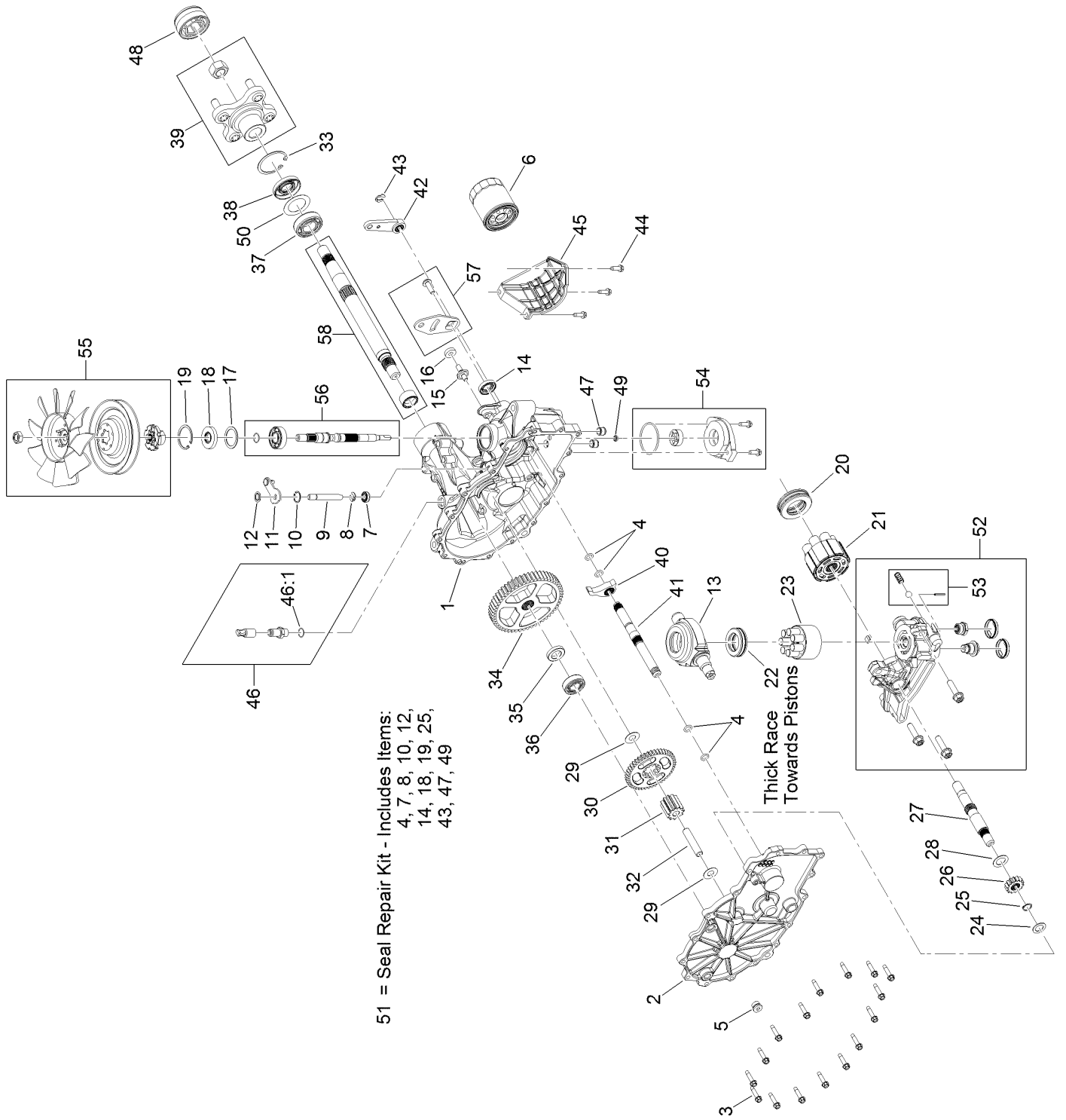

LH Hydro Transmission Assembly No. 127-3381 (continued)

<i>Ref.</i>	<i>Part Number</i>	<i>Qty.</i>	<i>Description</i>	<i>Ref.</i>	<i>Part Number</i>	<i>Qty.</i>	<i>Description</i>
1	114-8471	1	Main Housing Kit	31	120-7974	1	Gear-11T
2	114-8472	1	Side Cover Kit	32	104-5329	1	Pin-Jackshaft
3	117-5359	16	Screw-HHF	33	104-2169	1	Ring-Retaining
4	114-1678	4	O-Ring	34	114-1694	1	Gear-54T
5	104-2189	1	Plug-Thread, Straight	35	120-7975	1	Spacer
6	109-3321	1	Element-Oil Filter, HYD	36	126-1929	1	Bearing-Ball
7	106-8676	1	Seal-Lip	37	120-7976	1	Bearing-Ball
8	106-8677	1	Ring-Retaining, EXT	38	104-2144	1	Seal
9	114-1685	1	Rod-Bypass	39	109-5939	1	Hub Kit
10	106-8679	1	Ring-Retaining, Int	40	114-1697	1	Pawl-Brake
11	107-2490	1	Arm-Bypass	41	131-0907	1	Shaft-Brake
12	106-8681	1	Ring-Retaining, EXT	42	125-0021	1	Handle-Brake
13	104-5304	1	Swashplate-Trunnion	43	131-0906	1	Ring-Retaining, EXT
14	104-5313	1	Seal-Lip	44	104-2120	3	Screw
15	104-2116	1	Stud	45	120-7979	1	Guard-Filter, LH
16	112-9853	1	Puck-Friction	46	109-3278	1	Adapter-Straight
17	104-5308	1	Spacer	46:1	237-42	1	O-Ring
18	104-5310	1	Seal-Lip	47	114-8455	2	Tube-Connecting
19	104-5309	1	Ring-Retaining	48	115-5057	1	Cover-Nut, Axle
20	112-4154	1	Bearing-Thrust	49	131-0908	1	Seal-Gerotor
21	114-1689	1	Motor Cylinder Block Kit	50	121-5745	1	Spacer
22	94-6922	1	Bearing-Thrust	51	109-3537	1	Seal Kit
23	110-8561	1	Pump Block ASM	52	131-0909	1	LH Center Section Charge Kit
24	104-5339	1	Washer-Flat	53	114-8464	1	Charge Relief Kit
25	104-5340	1	Ring-Retaining	54	114-8465	1	Charge Kit
26	131-0905	1	Gear-14T	55	125-0059	1	Fan And Pulley Kit
27	114-1691	1	Shaft-Motor	56	117-5361	1	Input Shaft Kit
28	104-5360	1	Washer	57	117-5362	1	Arm Control Kit
29	94-1933	2	Washer	58	114-8470	1	Axle Shaft Kit
30	114-1692	1	Gear-45T				

RH Hydro Transmission Assembly No. 127-3382

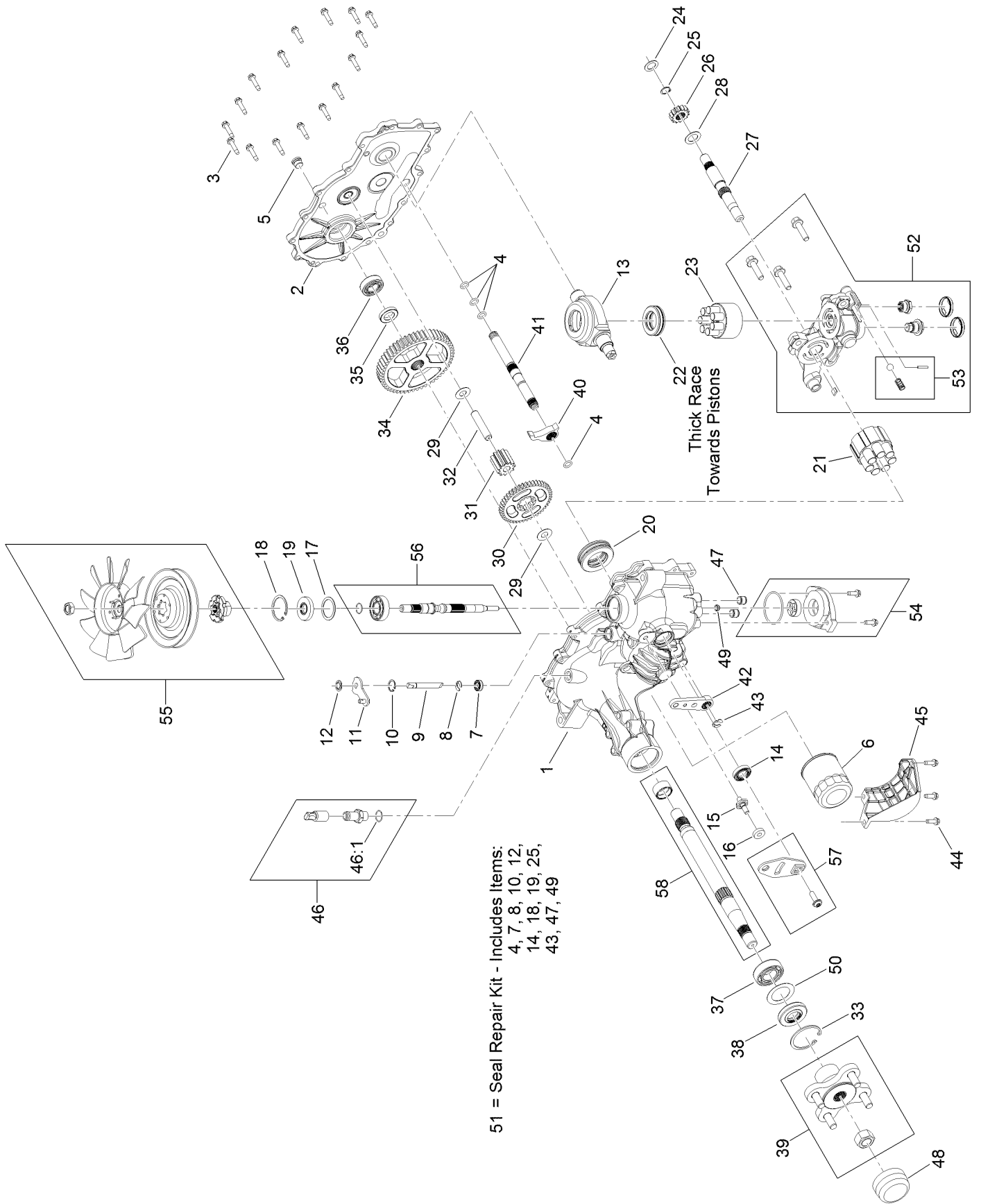

RH Hydro Transmission Assembly No. 127-3382 (continued)

<i>Ref.</i>	<i>Part Number</i>	<i>Qty.</i>	<i>Description</i>	<i>Ref.</i>	<i>Part Number</i>	<i>Qty.</i>	<i>Description</i>
1	114-1676	1	Main Housing Kit	31	120-7974	1	Gear-11T
2	117-5358	1	Housing Side Kit	32	104-5329	1	Pin-Jackshaft
3	117-5359	16	Screw-HHF	33	104-2169	1	Ring-Retaining
4	114-1678	4	O-Ring	34	114-1694	1	Gear-54T
5	104-2189	1	Plug-Thread, Straight	35	120-7975	1	Spacer
6	109-3321	1	Element-Oil Filter, HYD	36	126-1929	1	Bearing-Ball
7	106-8676	1	Seal-Lip	37	120-7976	1	Bearing-Ball
8	106-8677	1	Ring-Retaining, EXT	38	104-2144	1	Seal
9	114-1685	1	Rod-Bypass	39	109-5939	1	Hub Kit
10	106-8679	1	Ring-Retaining, Int	40	114-1697	1	Pawl-Brake
11	107-2490	1	Arm-Bypass	41	131-0907	1	Shaft-Brake
12	106-8681	1	Ring-Retaining, EXT	42	125-0021	1	Handle-Brake
13	104-5304	1	Swashplate-Trunnion	43	131-0906	1	Ring-Retaining, EXT
14	104-5313	1	Seal-Lip	44	104-2120	3	Screw
15	104-2116	1	Stud	45	120-7981	1	Guard-Filter, RH
16	112-9853	1	Puck-Friction	46	109-3278	1	Adapter-Straight
17	104-5308	1	Spacer	46:1	237-42	1	O-Ring
18	104-5310	1	Seal-Lip	47	114-8455	2	Tube-Connecting
19	104-5309	1	Ring-Retaining	48	115-5057	1	Cover-Nut, Axle
20	112-4154	1	Bearing-Thrust	49	131-0908	1	Seal-Gerotor
21	114-1689	1	Motor Cylinder Block Kit	50	121-5745	1	Spacer
22	94-6922	1	Bearing-Thrust	51	109-3537	1	Seal Kit
23	110-8561	1	Pump Block ASM	52	131-0910	1	RH Center Section Charge Kit
24	104-5339	1	Washer-Flat	53	114-8464	1	Charge Relief Kit
25	104-5340	1	Ring-Retaining	54	114-8465	1	Charge Kit
26	131-0905	1	Gear-14T	55	125-0059	1	Fan And Pulley Kit
27	114-1691	1	Shaft-Motor	56	117-5361	1	Input Shaft Kit
28	104-5360	1	Washer	57	117-5362	1	Arm Control Kit
29	94-1933	2	Washer	58	114-8470	1	Axle Shaft Kit
30	114-1692	1	Gear-45T				

Motion Control Assembly

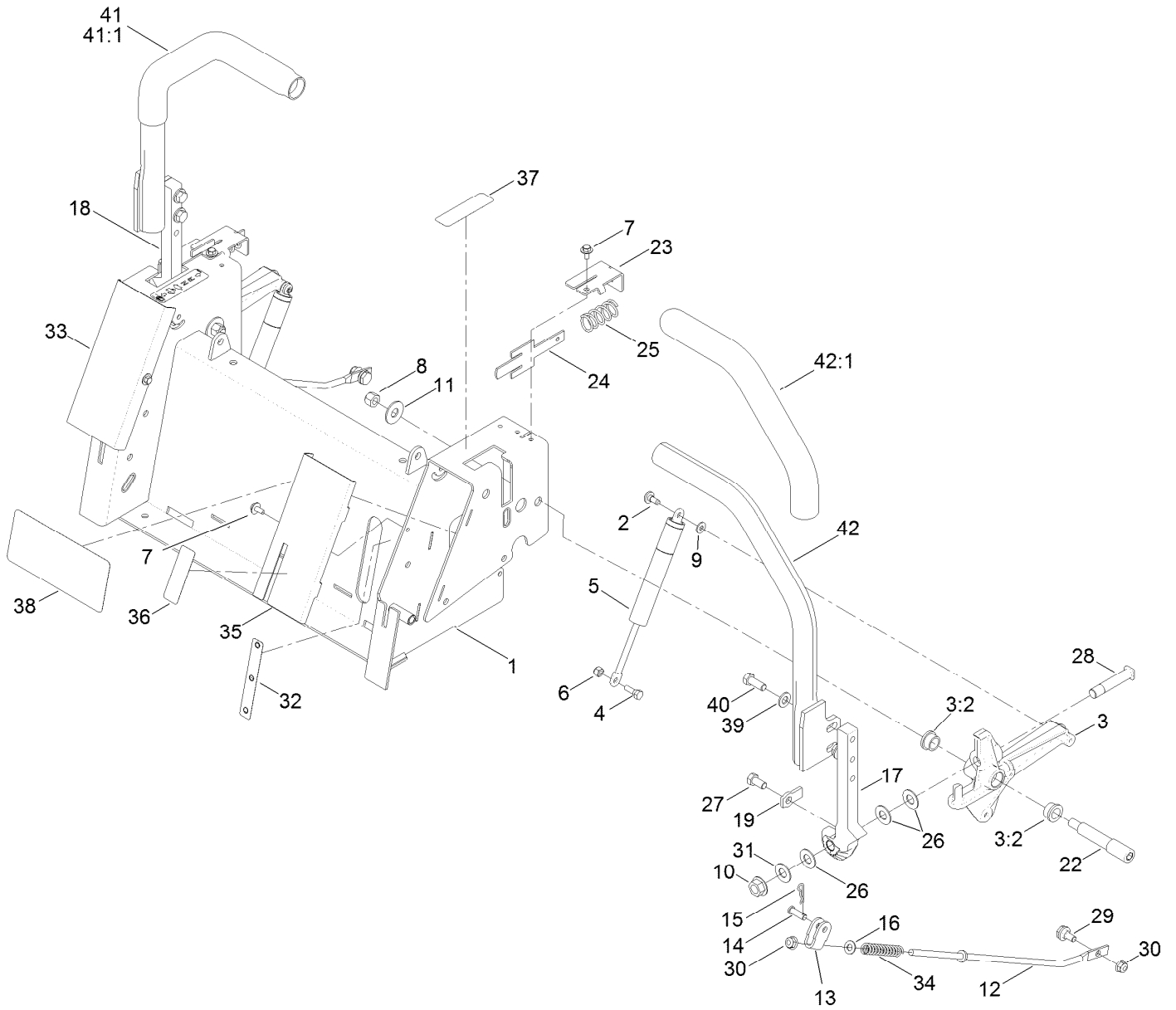

Motion Control Assembly (continued)

<i>Ref.</i>	<i>Part Number</i>	<i>Qty.</i>	<i>Description</i>	<i>Ref.</i>	<i>Part Number</i>	<i>Qty.</i>	<i>Description</i>
1	127-3282-03	1	Box-Control	24	110-6750	2	Plate-Return
2	120-7950	2	Screw-Shoulder	25	110-6752	2	Spring-Compression
3	110-6828	2	Activator Arm ASM	26	110-6894	6	Washer-Pivot
3:2	105-3455	2	Bushing	27	323-4	2	Screw-HH
4	106-2214	2	Bolt-Shoulder	28	110-6784	2	Bolt-Shoulder
5	109-2339	2	Damper-Control, Motion	29	37-8771	2	Bolt-Shoulder
6	3296-42	2	Nut-Lock, NI	30	104-8300	4	Nut-Flange, NI
7	46-8560	4	Screw-HHFTF	31	112-9771	2	Washer-Teflon
8	3296-48	2	Nut-Lock, NI	32	130-0655	1	Decal-Fill, Fuel
9	119-8952	2	Washer	33	117-1255-03	1	Cover-Control, RH
10	32128-23	2	Nut-HF	34	1-603807	2	Spring-Return, Neutral
11	3256-5	2	Washer-Flat	35	115-2561-03	1	Cover-Control, LH
12	117-7422	2	Rod-Control	36	115-9625	1	Decal
13	117-7423	2	Bracket-Control	37	99-8936	2	Decal-Control, Motion
14	1-808280	2	Pin-Clevis	38	127-3387	1	Decal
15	1-806003	2	Pin-Cotter, Hair	39	3256-24	4	Washer-Flat
16	3256-23	2	Washer-Flat	40	323-6	4	Screw-HH
17	110-6783-05	1	Arm-Actuator, LH	41	127-3441	1	RH Lever/Grip ASM
18	110-6782-05	1	Arm-Actuator, RH	41:1	106-9987	1	Grip-Control, Motion
19	115-5023	2	Tab-Stop	42	127-3442	1	LH Lever/Grip ASM
22	110-6875	2	Bolt-Shoulder	42:1	106-9987	1	Grip-Control, Motion
23	110-6751	2	Bracket-Return				

Brake Link Assembly

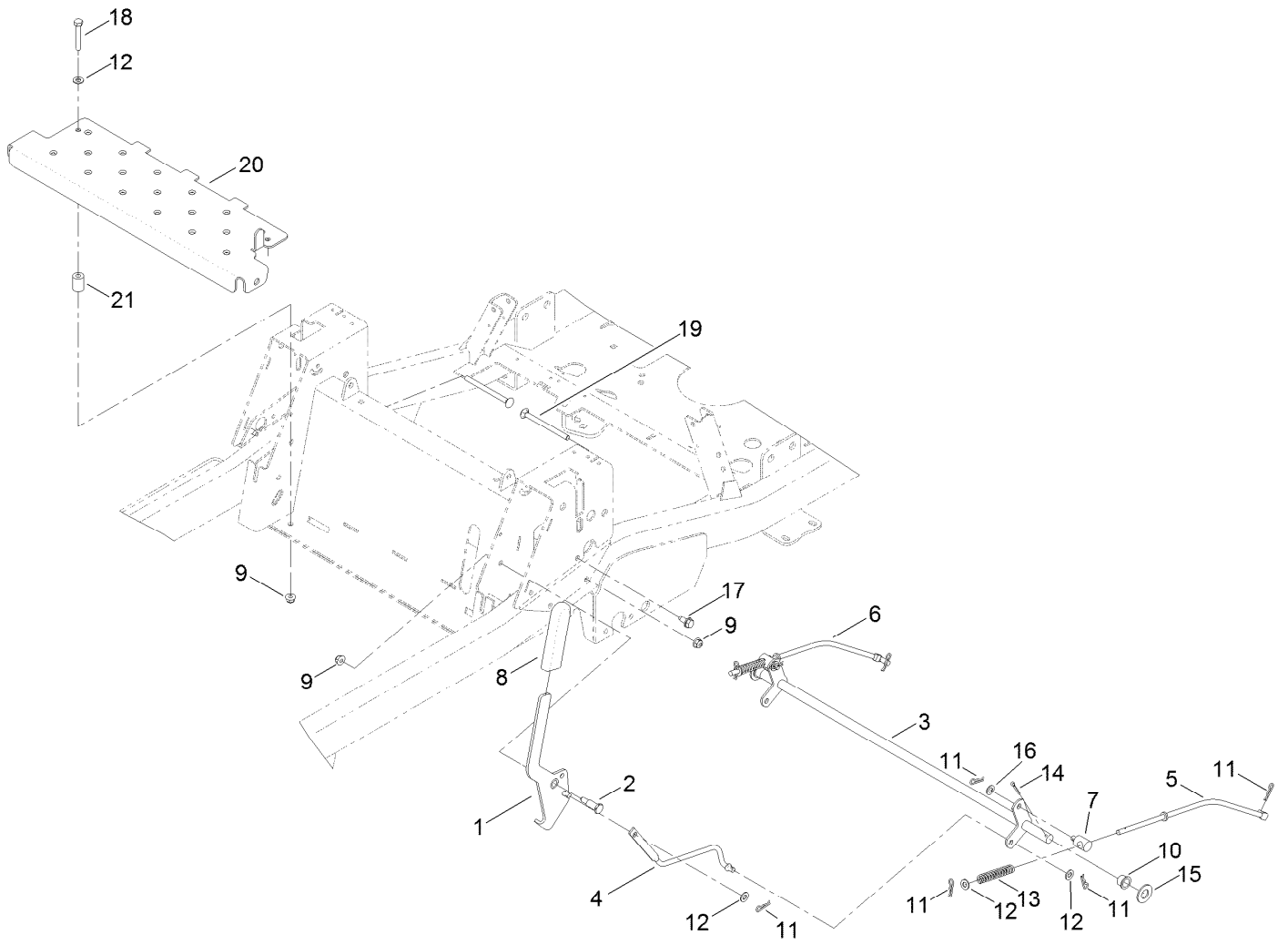

Brake Link Assembly (continued)

<i>Ref.</i>	<i>Part Number</i>	<i>Qty.</i>	<i>Description</i>	<i>Ref.</i>	<i>Part Number</i>	<i>Qty.</i>	<i>Description</i>
1	119-3460	1	Handle-Brake	12	3256-23	6	Washer-Flat
2	63-2650	1	Screw-Shoulder	13	1-603807	2	Spring-Return, Neutral
3	115-5071-03	1	Brake-Bellcrank	14	3272-11	2	Pin-Cotter
4	115-5074	1	Link-Brake	15	3256-27	2	Washer-Flat
5	117-7322	1	Rod-Brake, LH	16	40-1940	2	Washer
6	117-7323	1	Rod-Brake, RH	17	32144-70	4	Screw-HWHTF
7	115-9681	2	Fitting-Rod	18	322-10	2	Screw-HH
8	1-633268	1	Grip-Lever	19	106-9758	2	Screw-CARR
9	104-8300	5	Nut-Flange, NI	20	127-3435-01	1	Plate-Support, Floor Pan
10	256-292	2	Bushing-Flange, NI	21	119-0718	2	Spacer
11	1-806003	8	Pin-Cotter, Hair				

Engine, Muffler and Clutch Assembly

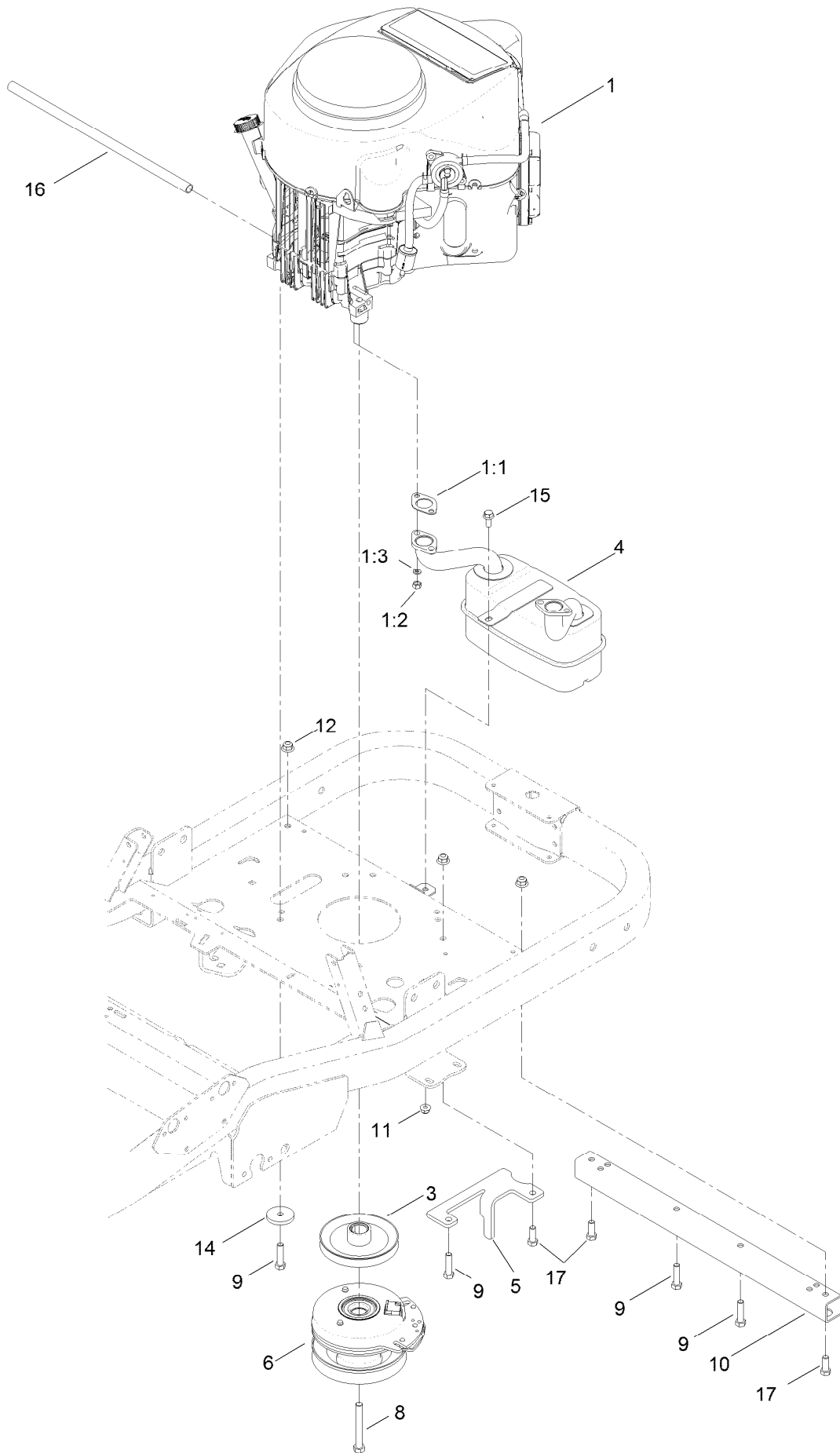

Engine, Muffler and Clutch Assembly (continued)

<i>Ref.</i>	<i>Part Number</i>	<i>Qty.</i>	<i>Description</i>	<i>Ref.</i>	<i>Part Number</i>	<i>Qty.</i>	<i>Description</i>
1		1	Engine-Kawasaki, Fr691V-S12-R ●■	8	3212-13	1	Screw-HH
				9	323-50	4	Bolt-HH
1:1	1-653313	2	Gasket-Exhaust	10	117-7335-03	1	Tube-Stiffener
1:2	114-3549	4	Nut	11	104-8300	1	Nut-Flange, NI
1:3	114-3550	4	Washer-Lock, Spring	12	104-8301	3	Nut-Flange, NI
3	125-5576	1	Pulley-Engine	14	110-9981	1	Washer-Plain
4	125-1760	1	Muffler	15	3234-47	1	Screw-HHF
5	117-7344-03	1	Bracket-Stop, PTO	16	106-7022	1	Tube-Drain, Oil
6	127-3410	1	Clutch-PTO	17	323-6	3	Screw-HH

● Not serviced separately

■ Obtain parts from www.kawpowerepc.com

Fuel Delivery Assembly

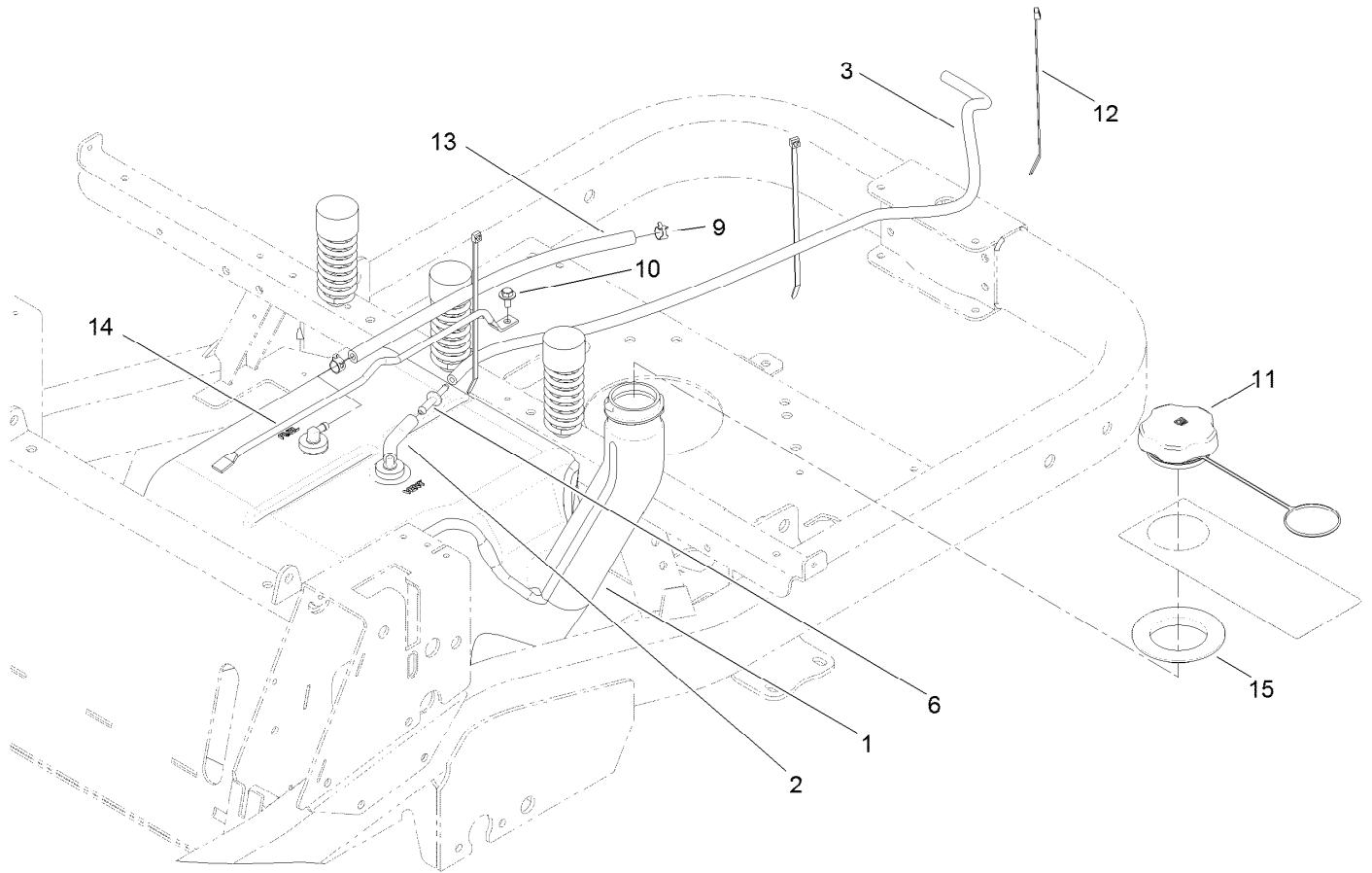

Fuel Delivery Assembly (continued)

<i>Ref.</i>	<i>Part Number</i>	<i>Qty.</i>	<i>Description</i>	<i>Ref.</i>	<i>Part Number</i>	<i>Qty.</i>	<i>Description</i>
1	117-7352	1	Multi Layer Fuel Tank ASM	11	125-1847	1	Cap-Fuel
2	114-3765	1	Hose-Fuel	12	614249	3	Tie-Cable
3	51-3212	1	Hose-Fuel	13	107-0589	1	Hose-Fuel
6	121-0743	1	Adapter-Orifice	14	115-2620	1	Rod-Tank, Gas
9	2412-98	2	Clamp-Hose	15	117-1298	1	Seal-Tank
10	46-8560	1	Screw-HHFTF				

Multi Layer Fuel Tank Assembly No. 117-7352

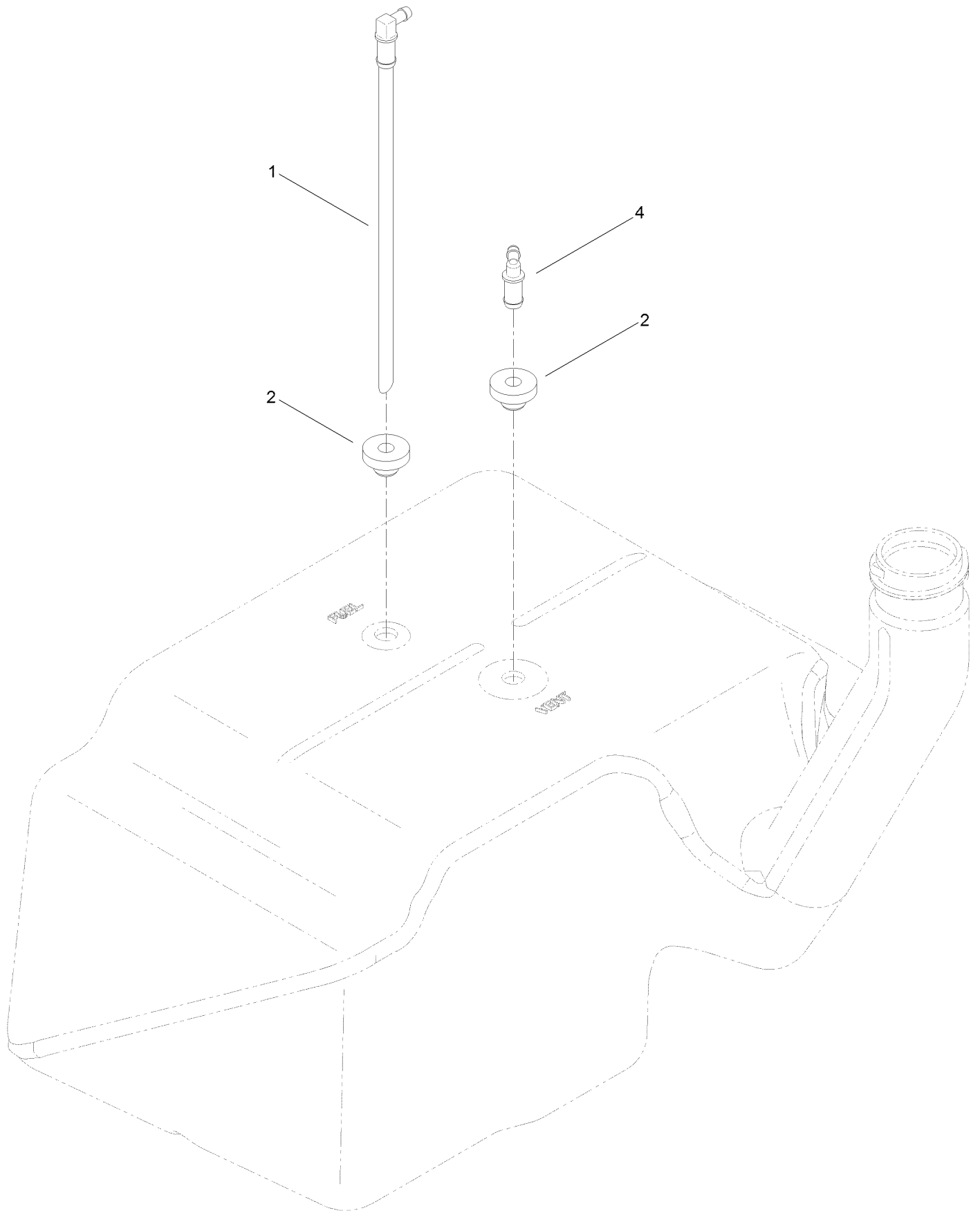

Multi Layer Fuel Tank Assembly No. 117-7352 (continued)

<i>Ref.</i>	<i>Part Number</i>	<i>Qty.</i>	<i>Description</i>
1	121-0793	1	Connector-Elbow, 90 DEG
2	46-6560	2	Bushing
4	117-7400	1	Fitting-Plastic

Roll-Over Protection System Assembly

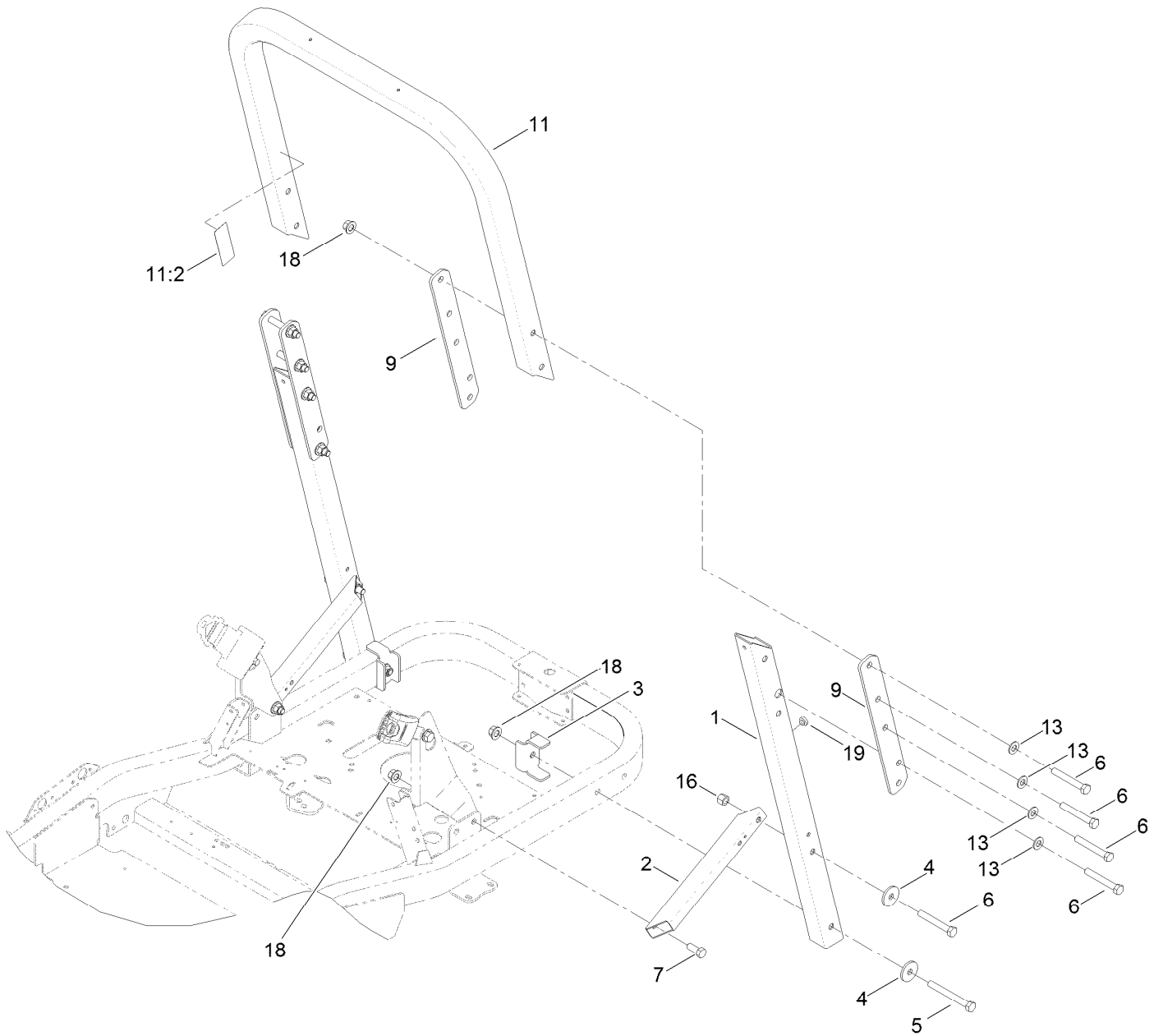

Roll-Over Protection System Assembly (continued)

<i>Ref.</i>	<i>Part Number</i>	<i>Qty.</i>	<i>Description</i>	<i>Ref.</i>	<i>Part Number</i>	<i>Qty.</i>	<i>Description</i>
1	121-2986-03	2	Tube-ROPS, Lower	9	127-3326-03	4	Plate-ROPS
2	115-4962-03	2	Tube-Support, ROPS	11	130-6929	1	Upper ROPS ASM
3	115-4963-03	2	Bracket-Reinforcing	11:2	130-6927	1	Decal-ROPS, Warning
4	84-1560	4	Washer-Thrust	13	3256-26	8	Washer-Flat
5	325-18	2	Screw-HH	16	119-8969	2	Nut-Hex
6	325-14	10	Screw-HH	18	99-5107	12	Nut-Lock
7	325-5	2	Screw-HH	19	1-513658	2	Bumper

Electrical Assembly

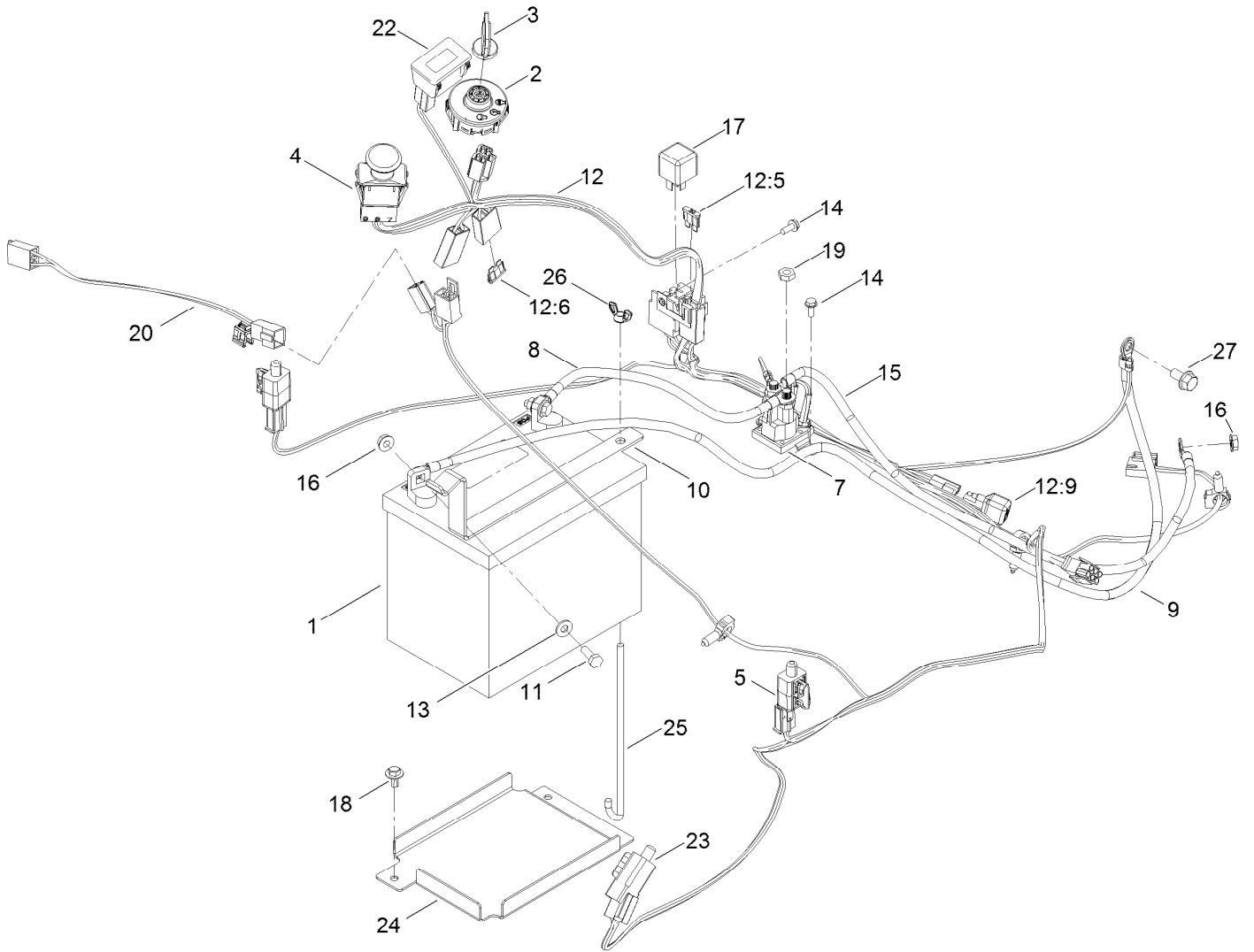

Electrical Assembly (continued)

<i>Ref.</i>	<i>Part Number</i>	<i>Qty.</i>	<i>Description</i>	<i>Ref.</i>	<i>Part Number</i>	<i>Qty.</i>	<i>Description</i>
1	105-1692	1	Battery	13	3256-22	2	Washer-Flat
2	117-2221	1	Switch-Ignition	14	32144-1	3	Screw-Taptite
3	63-8360	1	Key-Ignition	15	92-6989	1	Wire-21 Inch
4	103-5221	1	Switch-PTO	16	32128-33	3	Nut-HF
5	110-6765	2	Switch	17	98-7249	1	Relay
7	117-1197	1	Solenoid	18	46-8560	2	Screw-HHFTF
8	117-5342	1	Cable-Battery, Positive	19	3220-2	2	Nut-Jam
9	117-7240	1	Cable-Battery, Negative	20	130-0652	1	Harness-Wire
10	117-7313-01	1	Strap-Battery	22	120-2244	1	Hourmeter
11	321-4	2	Screw-HH	23	99-7408	1	Switch-Reverse
12	130-0651	1	Harness-Wire	24	117-1283-03	1	Tray-Battery
12:5	109103	1	Fuse-Blade, 30 Amp	25	1-633651	1	Bolt-Holddown
12:6	109102	1	Fuse-Blade, 25 Amp	26	1-543792	1	Wingnut
12:9	100-4918	1	Diode-Over Molded	27	33104-016	1	Screw-HHF

Seat Assembly

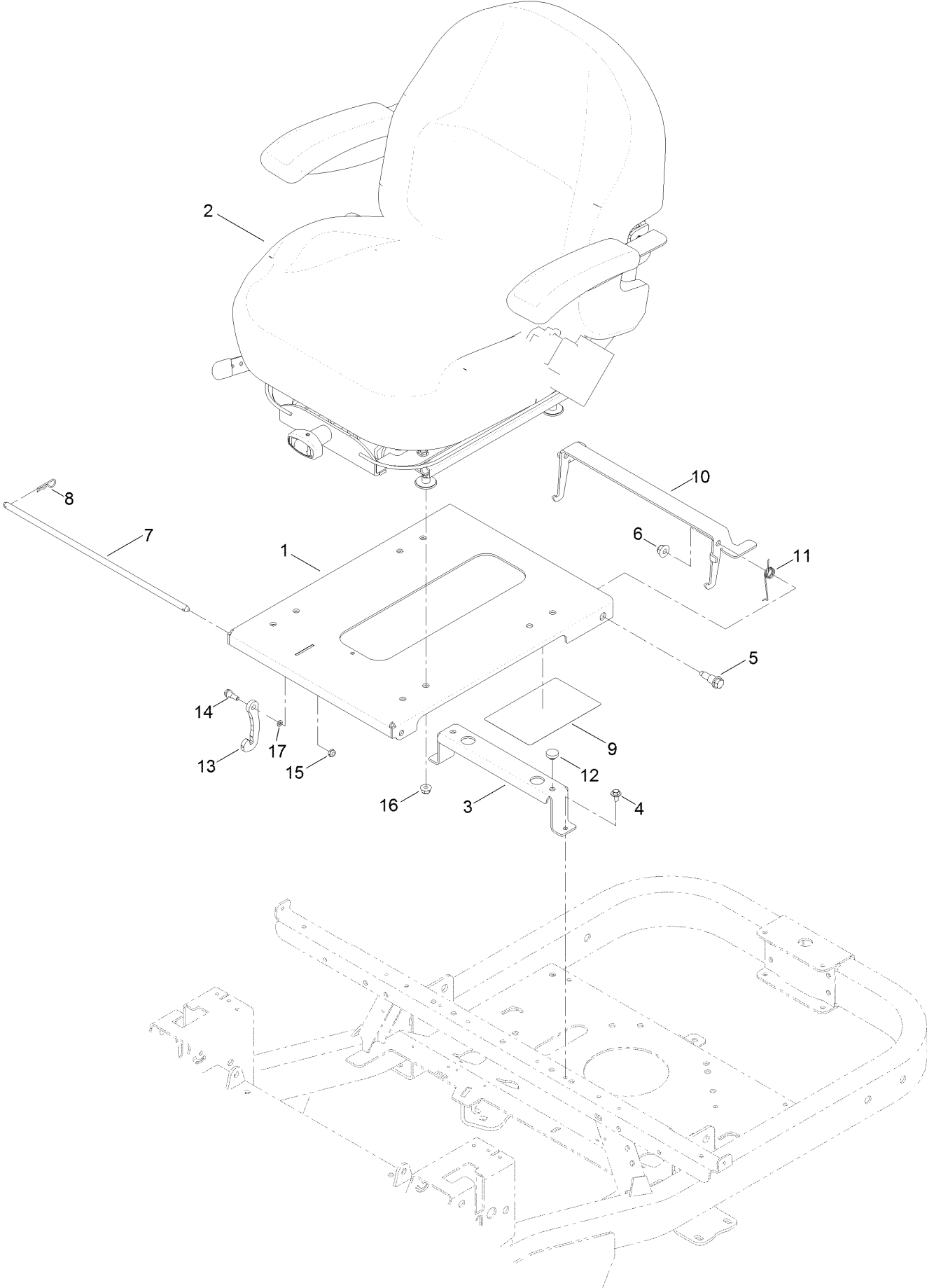

Seat Assembly (continued)

<i>Ref.</i>	<i>Part Number</i>	<i>Qty.</i>	<i>Description</i>	<i>Ref.</i>	<i>Part Number</i>	<i>Qty.</i>	<i>Description</i>
1	130-0677-03	1	Seat Pan ASM	10	127-3341	1	Latch-Seat
2	130-0801	1	Seat ASM	11	127-3365	1	Torsion-Spring
3	127-3370-03	1	Seat-Support, Rear	12	1-513658	2	Bumper
4	46-8560	2	Screw-HHFTF	13	130-0669	1	Stop-Seat
5	107-2979	2	Bolt-Shoulder	14	42-3560	1	Bolt-Shoulder
6	104-8301	2	Nut-Flange, NI	15	3296-56	1	Nut-Lock, NI
7	115-4966	1	Rod-Stop	16	104-8300	4	Nut-Flange, NI
8	3290-250	2	Pin-Hair	17	119-8952	1	Washer
9	115-9630	1	Decal-Maintenance				

Seat Assembly No. 130-0801

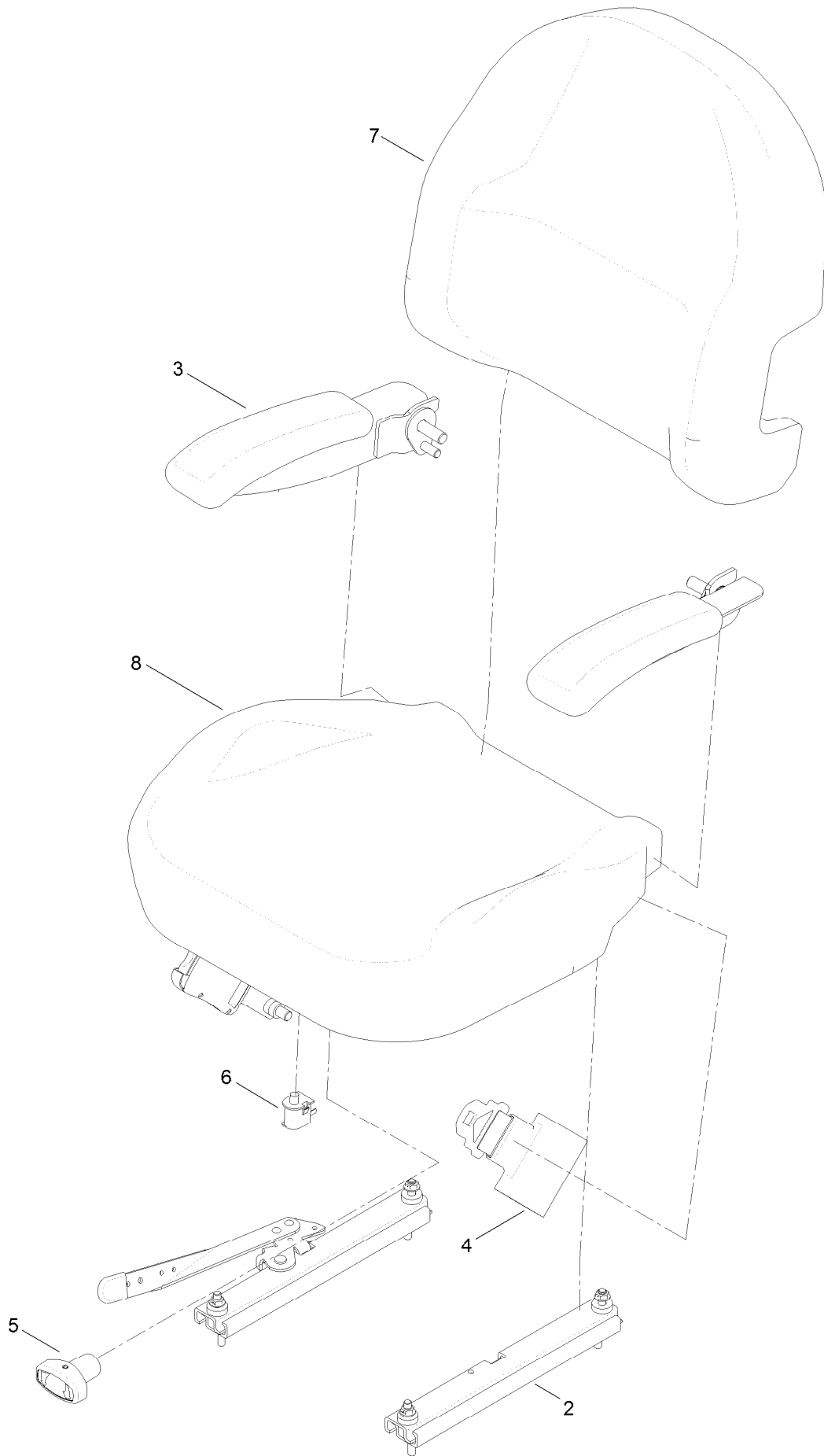

Seat Assembly No. 130-0801 (continued)

<i>Ref.</i>	<i>Part Number</i>	<i>Qty.</i>	<i>Description</i>
2	130-0844	1	Track ASM
3	126-2058	1	Armrest Kit
4	130-0845	1	Seat Belt Kit
5	130-0846	1	Knob-Adjuster

<i>Ref.</i>	<i>Part Number</i>	<i>Qty.</i>	<i>Description</i>
6	82-2190	1	Switch-Bail
7	130-0847	1	Cover-Back
8	130-0848	1	Cover-Cushion

54 Inch Deck Assembly

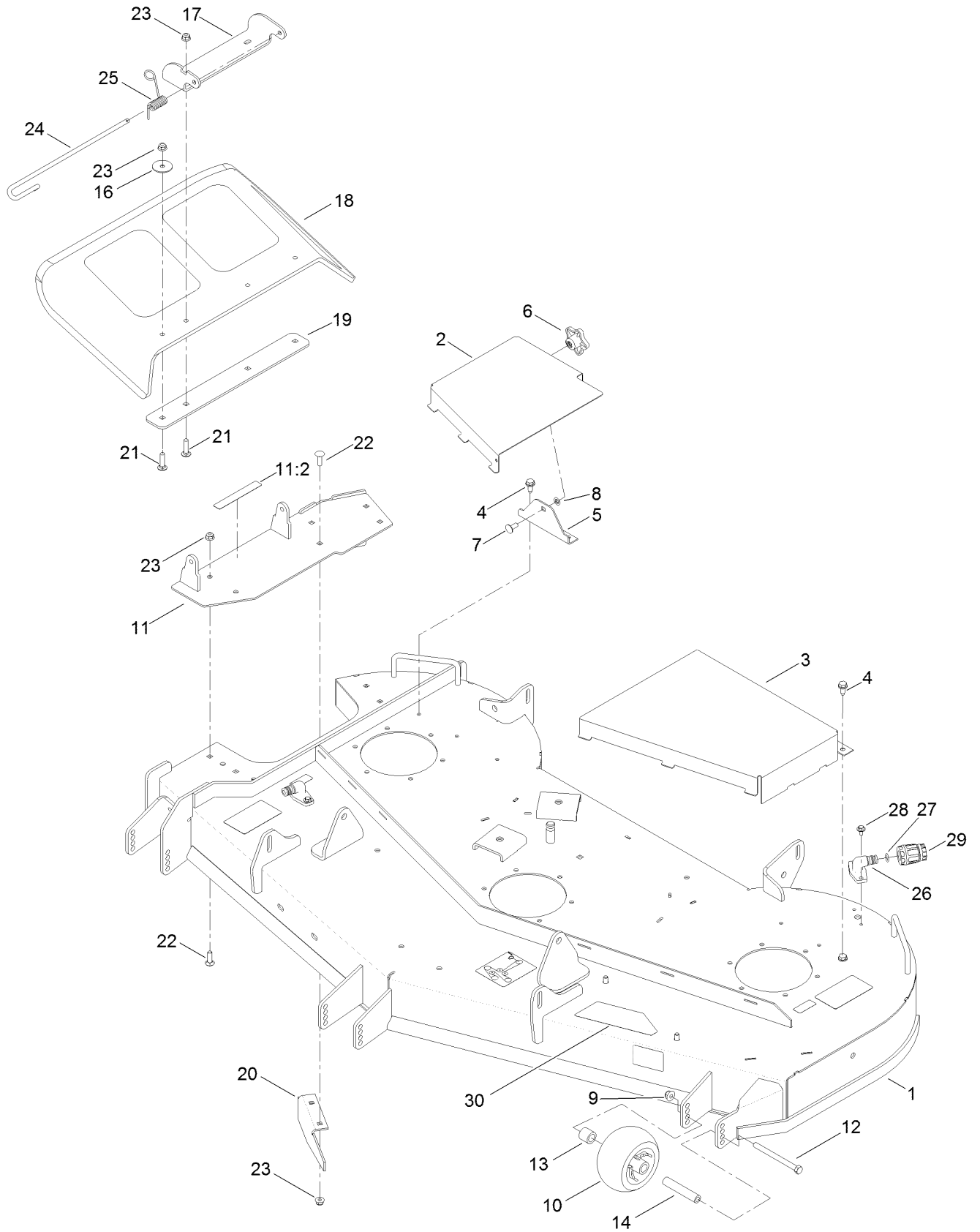

54 Inch Deck Assembly (continued)

<i>Ref.</i>	<i>Part Number</i>	<i>Qty.</i>	<i>Description</i>	<i>Ref.</i>	<i>Part Number</i>	<i>Qty.</i>	<i>Description</i>
1	127-3280	1	54 Inch Deck ASM	16	3256-68	2	Washer-Flat
2	127-3297-05	1	Cover-Belt, RH	17	114-1648-05	1	Bracket-Deflector, Upper
3	127-3298-05	1	Cover-Belt, LH	18	117-1270	1	Deflector-Molded
4	32144-70	4	Screw-HWHTF	19	115-5048-03	1	Plate-Deflector
5	127-3290-03	2	Bracket-Support	20	115-9653-03	1	Baffle-Cutoff
6	117-5976	2	Knob-Handle	21	3230-3	4	Screw-CARR
7	3230-23	2	Screw-CARR	22	3230-22	4	Screw-CARR
8	109-5667	2	Ring-Retaining, Bolt	23	104-8300	8	Nut-Flange, NI
9	104-8301	3	Nut-Flange, NI	24	109-8854	1	Pin-Chute
10	1-603299	3	Roller-Scalp, Anti	25	121-2983	1	Spring-Torsion
11	130-0763	1	Pivot-Deflector	26	95-2747	2	Fitting-Washout
11:2	130-0731	1	Decal-Deflector, Danger	27	46-6290	2	O-Ring
12	323-23	3	Screw-HH	28	46-8560	4	Screw-HHFTF
13	104-0892	3	Spacer-Axle, Rear	29	95-3270	1	Connector-Hose
14	98-7912	3	Tube-Spanner	30	117-5302	1	Decal

54 Inch Deck, Belt and Mulch Blade Asseembly (continued)

<i>Ref.</i>	<i>Part Number</i>	<i>Qty.</i>	<i>Description</i>	<i>Ref.</i>	<i>Part Number</i>	<i>Qty.</i>	<i>Description</i>
1	7-4150	3	Washer	12	110-9981	3	Washer-Plain
2	120-5477	3	Spindle ASM	13	114-0463	2	Washer-Friction, Composite
2:2	116-0720	2	Bearing-Ball	14	1-413088	1	Bushing-Lever, Lift
2:3	115-2641	1	Spacer-Bearing	15	115-5054	1	Arm-Idler
3	32144-41	18	Screw-Taptite	16	323-10	1	Screw-HH
4	117-7210	3	Shield-Bearing	17	104-8301	3	Nut-Flange, NI
5	115-2642	3	Shaft-Spindle	18	115-2577	3	Bushing-Idler
6	115-5018	3	Pulley	19	116-3626	3	Pulley-Idler
7	1-603401	1	Spacer-Fender	20	3231-31	1	Screw-CARR
8	115-9650-03	3	Blade-Hi Flo	21	80-6990	3	Washer-Hardened
9	125-1736	3	Washer-Belleville	22	323-9	3	Screw-HH
10	51-4060	3	Screw-Blade	23	108-4056	1	Spring-Extension
11	3219-7	3	Nut-Hex	24	115-4971	1	V-Belt

54 Inch Deck and Decal Assembly

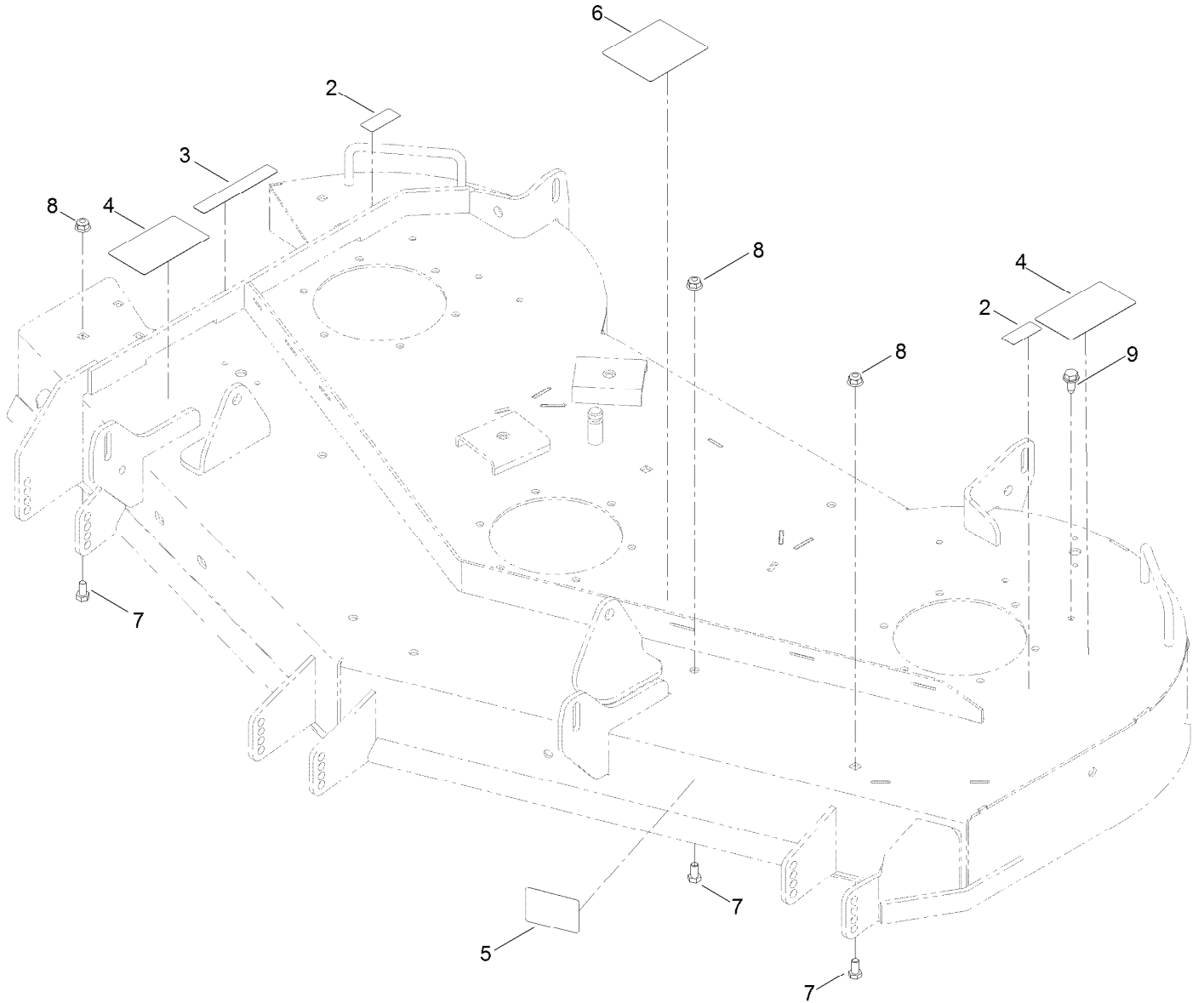

54 Inch Deck and Decal Assembly (continued)

<i>Ref.</i>	<i>Part Number</i>	<i>Qty.</i>	<i>Description</i>	<i>Ref.</i>	<i>Part Number</i>	<i>Qty.</i>	<i>Description</i>
2	114-1606	2	Decal-Danger	6	117-1194	1	Decal-Routing, Belt
3	130-0731	1	Decal-Deflector, Danger	7	322-2	3	Screw-HH
4	130-6928	2	Decal-Danger	8	104-8300	3	Nut-Flange, NI
5	130-0765	1	Decal-Scalp, Anti	9	32144-70	1	Screw-HWHTF

Attachments and Accessories

For 74882 TITAN MX5400 Zero-Turn-Radius Riding Mower

Product Name	Model/Part
54in Recycler Kit.....	117-5313
Light Kit.....	117-5317
54in/60in Striping Kit.....	117-5319
Leaf Bagging Enhancement Kit	117-7202
54in Bagger Finishing Kit (Used with 79328 Bagger)	121-5663
MVP Filter, Belt and Blade Kit	127-1629
ROPS Conversion Kit	130-6850
Cargo Carrier	79032
Front Weight Kit.....	79033
Bagger Kit.....	79328
E-Z Vac Twin Bagger	79330
54in Blower and Drive Kit.....	79341

Notes:



Count on it.