



Count on it.

Parts Catalog

Finishing Kit

**DPA Cutting Unit with 5in Reel Reelmaster®
5010-H Series Traction Unit**

Model No. 03628



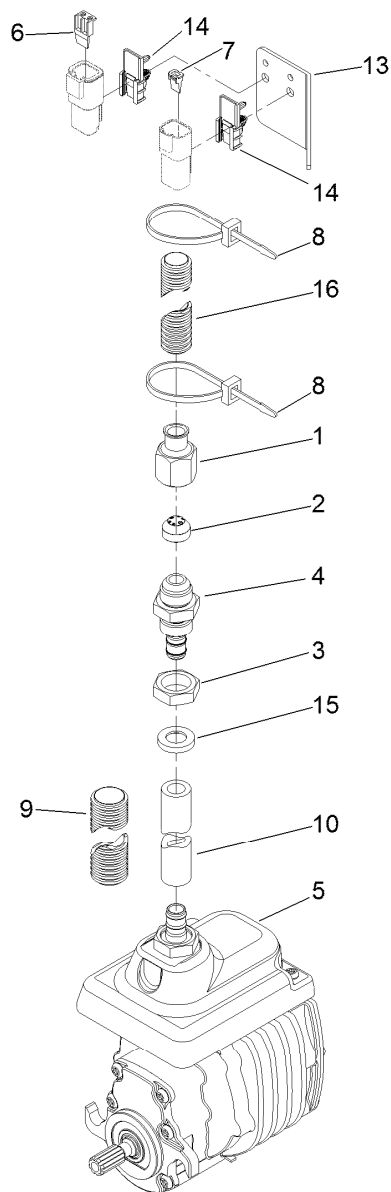

5 Inch Electric Motor Assembly No. 125-1450

<i>Ref.</i>	<i>Part Number</i>	<i>Qty.</i>	<i>Description</i>
1	119-7481	1	Nut-Ferrule
2	119-7480	1	Ferrule
3	119-7457	1	Nut
4	119-7545	1	Fitting-Bulkhead
5		1	Electric Motor ●
6	32180-083	1	Wedge
7	32180-084	1	Wedge
8	3290-378	4	Tie-Cable
9	127-2452	1	Tubing-Convoluted, Slit
10	127-2328	1	Hose
13	127-2451	1	Plate-Connector
14	32180-103	2	Clip-Connector, Deutsch
15	127-2360	1	Caplug
16	127-2527	1	Tubing-Convoluted, Slit

● Not serviced separately

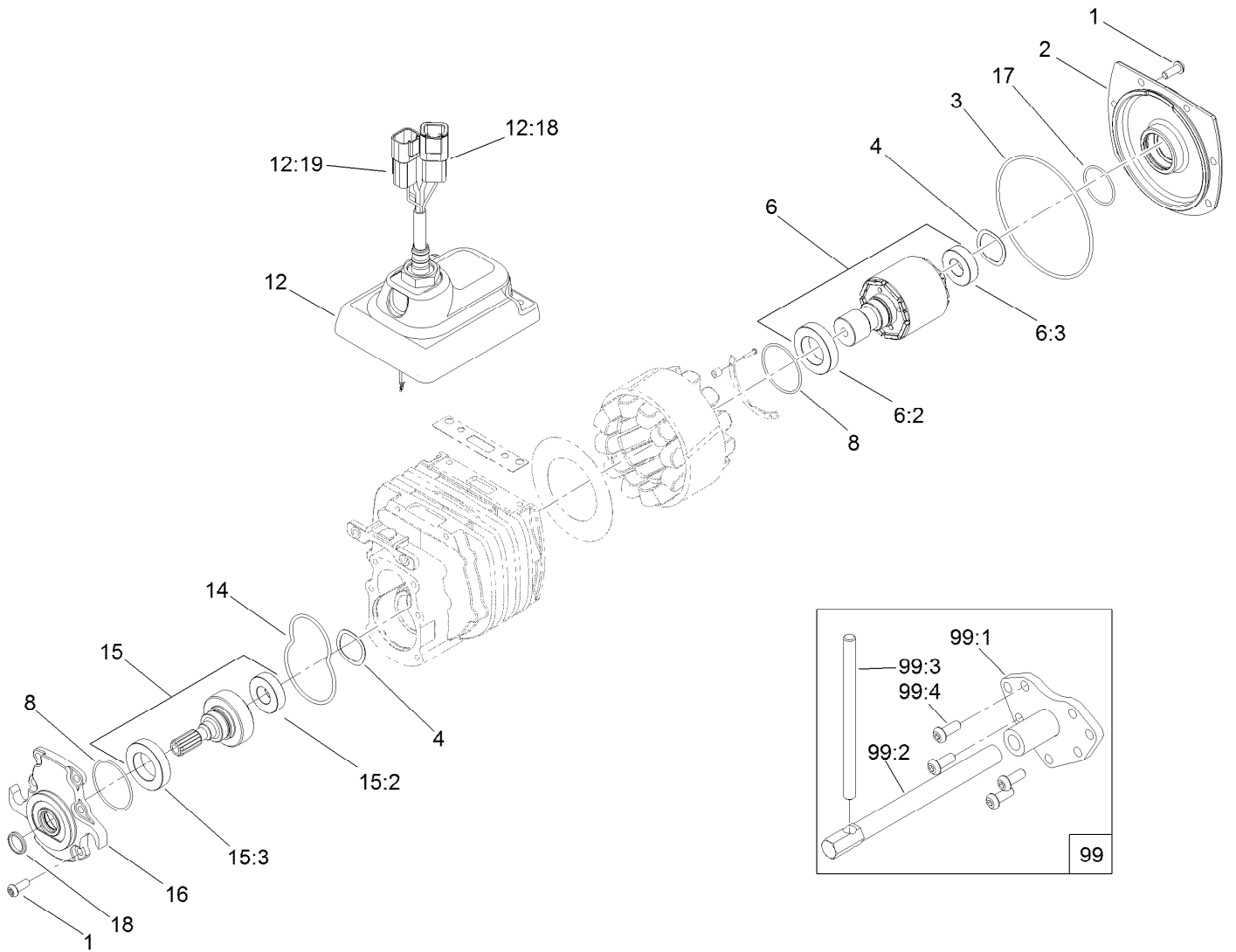

5 Inch Motor Assembly

Ref.	Part Number	Qty.	Description	Ref.	Part Number	Qty.	Description
1	120-4559	12	Screw-Bhcs	15	115-4782	1	Output Gear ASM
2	115-4779	1	Cover-Motor	15:2	120-4557	1	Bearing
3	112-9609	1	O-Ring	15:3	112-5158	1	Bearing-Ball
4	112-5163	2	Washer-Wave	16	125-1477	1	Cover-Gearbox
6	119-7450	1	Rotor ASM	17	119-1156	1	O-Ring
6:2	112-5158	1	Bearing-Ball	18	119-7451	1	Seal-Oil
6:3	120-4557	1	Bearing	99	127-2574	1	Rotor Puller ASM
8	112-9616	2	O-Ring	99:1	127-2573	1	Puller Hub ASM
12		1	Inverter/Controller ASM ●	99:2	119-1194	1	Rod-Threaded
12:18	32160-245	1	Connector	99:3	119-1184	1	Handle-Puller
12:19	32160-315	1	Connector	99:4	112-5150	4	Screw-Bhcs
14	112-9611	1	O-Ring				

● Not serviced separately



Count on it.