



Count on it.

Parts Catalog

55cm Recycler[®] Lawn Mower

Model No. 20958—Serial No. 315000001 and Up



Ordering Replacement Parts

To order replacement parts, please supply the part number, the quantity, and the description of each part desired.

Understanding Reference Numbers

Each identified part in an illustration has a reference number. The reference number for a part also appears in the parts list, along with other information about the part.

This catalog uses two special reference number formats, one to indicate parts in a service assembly and another to indicate the quantity of a given part in an illustration.

Service Assembly Reference Numbers

Parts in service assemblies have reference numbers in the form a:b. The a represents the reference number of the entire service assembly and the b represents a sequential number unique to each part within the service assembly.

For example, a wheel assembly might be identified by reference number 6, the tire by 6:1, the valve by 6:2, and the wheel by 6:3. When you order the assembly identified by reference number 6, you receive all parts identified by reference numbers 6:1, 6:2, and 6:3. However, you may also order any part individually. Reference numbers of this type appear in illustration and in parts lists.

Reference Numbers Indicating Quantity

In an illustration, if a reference number indicates more than one part, the reference number has the form nX y. The n represents the quantity of the part, the X is the multiplication symbol, and the y represents the reference number.

For example, in an illustration, the reference number 2X 37 means that two of the parts identified by reference number 37 are indicated.

List of Abbreviations

AR: as required

ASM: assembly

BBC: blade brake control

BHTF: button head thread forming

CARR: carriage

CCW: counter clockwise

CW: clockwise

DEG: degrees

DPA: Dual Point Adjustment

ECM: electronic control module

EXT: external

FH: flat head

GA: gauge

HD: heavy-duty

HF: hex flange

HH: hex head

HHF: hex head flange

HHFTF: hex head flange thread forming

HJ: hex jam

HLH: hex lag head

HOC: height-of-cut

HP: high pressure

HSBH: hex socket button head

HSFH: hex socket flat head

HSH: hex socket head

HWH: hex washer head

HWHTF: hex washer head thread forming

HYD: hydraulic

LH: left hand

LP: low pressure

LPG: Liquefied Petroleum Gas

NI: nylon insert

NPTF: national pipe thread fine

PFH: phillips flat head

PPH: phillips pan head

PPHTF: phillips pan head thread forming

PRH: phillips round head

PTH: phillips truss head

PTO: power-take-off

RH: right hand

ROPS: roll-over protection system

RRB: rear roller brush

SFH: slotted fillister head

SHH: slotted hex head

SHWH: slotted hex washer head

SPH: slotted pan head

SQH: square head

SRH: slotted round head

STD: standard

TAP: self tapping

TTH: torx truss head

Contents

Deck, Side Chute and Rear Door Assembly	4
Rear Bag Assembly	6
Engine and Blade Assembly	8
Front Wheel and Height-of-Cut Assembly	10
Transmission and Rear Wheel Drive Assembly	12
Upper Handle Assembly	14
Upper Handle Component Assembly	16
Attachments and Accessories	18

Deck, Side Chute and Rear Door Assembly

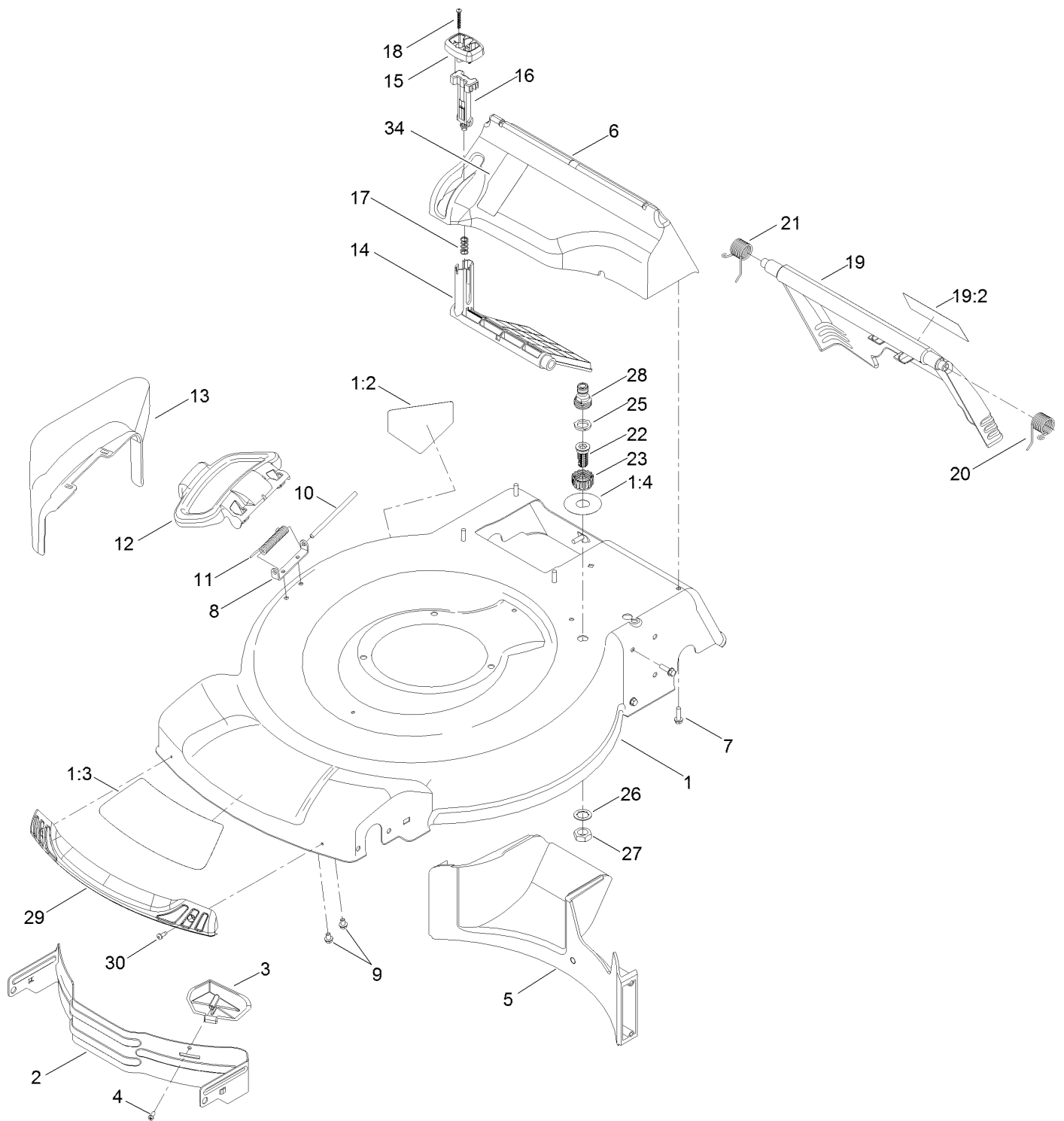

Deck, Side Chute and Rear Door Assembly (continued)

<i>Ref.</i>	<i>Part Number</i>	<i>Qty.</i>	<i>Description</i>	<i>Ref.</i>	<i>Part Number</i>	<i>Qty.</i>	<i>Description</i>
1	130-2390	1	Housing ASM	16	114-7959	1	Latch-Recycle
1:2	112-8760	1	Decal-Danger	17	117-1031	1	Spring-Compression
1:3	119-0283	1	Decal-Recycler	18	32104-120	2	Screw-PPH
1:4	112-8867	1	Decal-Washout Port	19	121-5776	1	Rear Door ASM
2	115-4667-01	1	Baffle-Front	19:2	131-4514	1	Decal-Warning
3	115-4672	1	Kicker-Front	20	115-2859	1	Spring-Torsion
4	32144-111	1	Screw-PPH	21	114-7924	1	Spring-Torsion
5	114-7961	1	Baffle-Rear	22	112-6400	1	Port-Washout
6	115-4677	1	Chute-Recycle	23	112-6401	1	Coupling-Hose, Washout Port
7	46-8091	9	Screw-HWH	25	112-6438	1	Washer-Seal, Washout Port
8	112-6416	1	Bracket-Cover	26	3254-5	1	Washer-Tooth, Internal
9	99-8445	2	Screw-HWH	27	3218-6	1	Nut-Jam
10	99-5291	1	Rod-Cover	28	112-6437	1	Adapter-Connect, Quick
11	99-5293	1	Spring-Torsion	29	114-7987	1	Bumper
12	115-8449	1	Deflector-Side	30	105-6849	2	Screw-Thread Forming
13	115-8447	1	Chute-Discharge, Side	34	125-5026	1	Decal-Bag On Demand
14	114-7960	1	Deflector-Recycle				
15	114-7958	1	Knob-Recycle				

Rear Bag Assembly

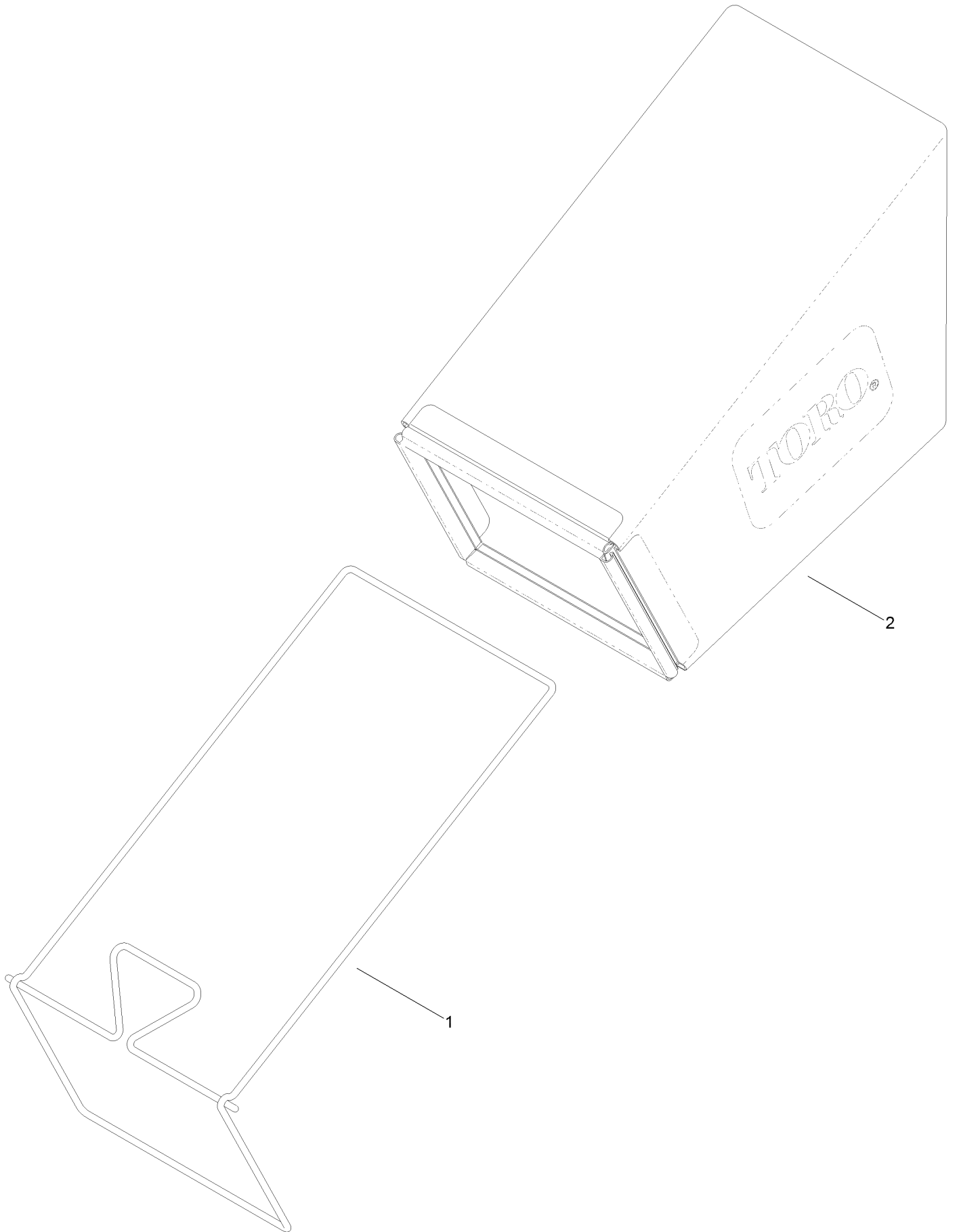

Rear Bag Assembly (continued)

<i>Ref.</i>	<i>Part Number</i>	<i>Qty.</i>	<i>Description</i>
1	114-2679-03	1	Frame-Bag
2	115-4673	1	Grass Bag ASM

Engine and Blade Assembly

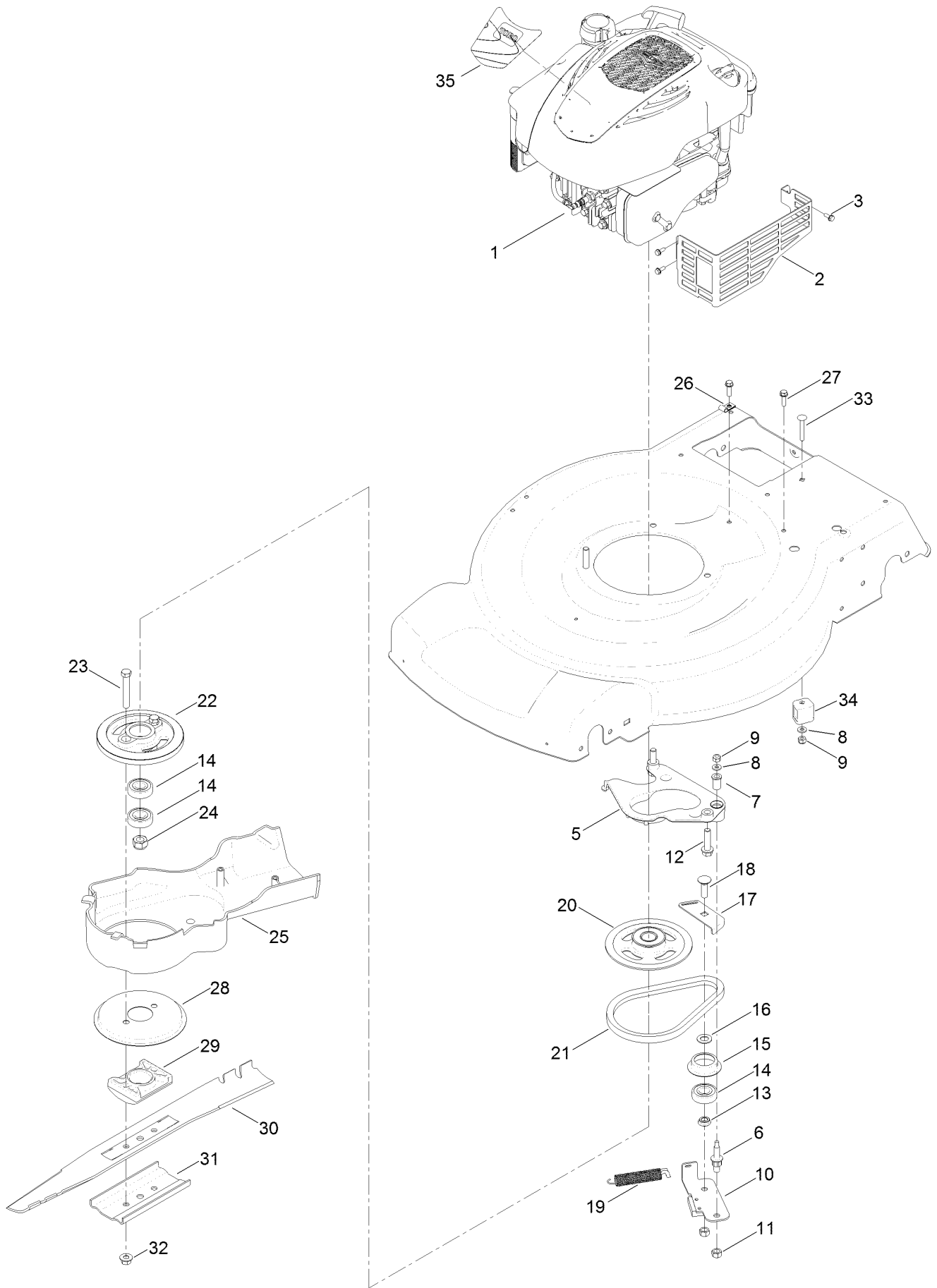

Engine and Blade Assembly (continued)

<i>Ref.</i>	<i>Part Number</i>	<i>Qty.</i>	<i>Description</i>	<i>Ref.</i>	<i>Part Number</i>	<i>Qty.</i>	<i>Description</i>
1		1	Engine-Briggs, 126M020120F1 ●■	19	108-3792	1	Spring-Tension, Brake
2	104-7577-03	1	Shield-Muffler	20	117-5970	1	Pulley-BBC
3	32144-1	3	Screw-Taptite	21	110-1790	1	Belt-BBC
5	108-9341	1	Plate-Anchor	22	107-0754	1	Drum
6	107-0759	1	Bolt-Shoulder	23	3211-42	2	Screw-HH
7	107-0797	1	Bushing	24	108-9342	1	Nut-Hex
8	3256-16	2	Washer-Flat	25	115-2892	1	Cover-BBC
9	3296-73	2	Nut-Lock, NI	26	2412-72	1	Clip-Closed, Insulated
10	125-1063	1	Plate-Brake	27	46-8091	2	Screw-HWH
11	125-5069	2	Nut-Hex	28	108-3787	1	Disc
12	32144-102	3	Screw-HWH	29	107-7487	1	Support-Blade
13	107-0758	1	Spacer-Bearing	30	108-9783-03	1	Blade
14	100-1048	3	Bearing-Ball	31	108-3766-03	1	Support-Blade
15	108-3790	1	Retainer-Belt	32	127-6852	2	Nut-Flange, Lock
16	605256	1	Washer-Plain	33	3229-5	1	Screw-CARR
17	107-7471	1	Plate-Guide	34	106-6801	1	Anchor-Cable, BBC
18	3231-25	1	Bolt-CARR	35	120-1935	1	Decal-Shroud

● Not serviced separately

■ Obtain parts from www.briggsandstratton.com

Front Wheel and Height-of-Cut Assembly

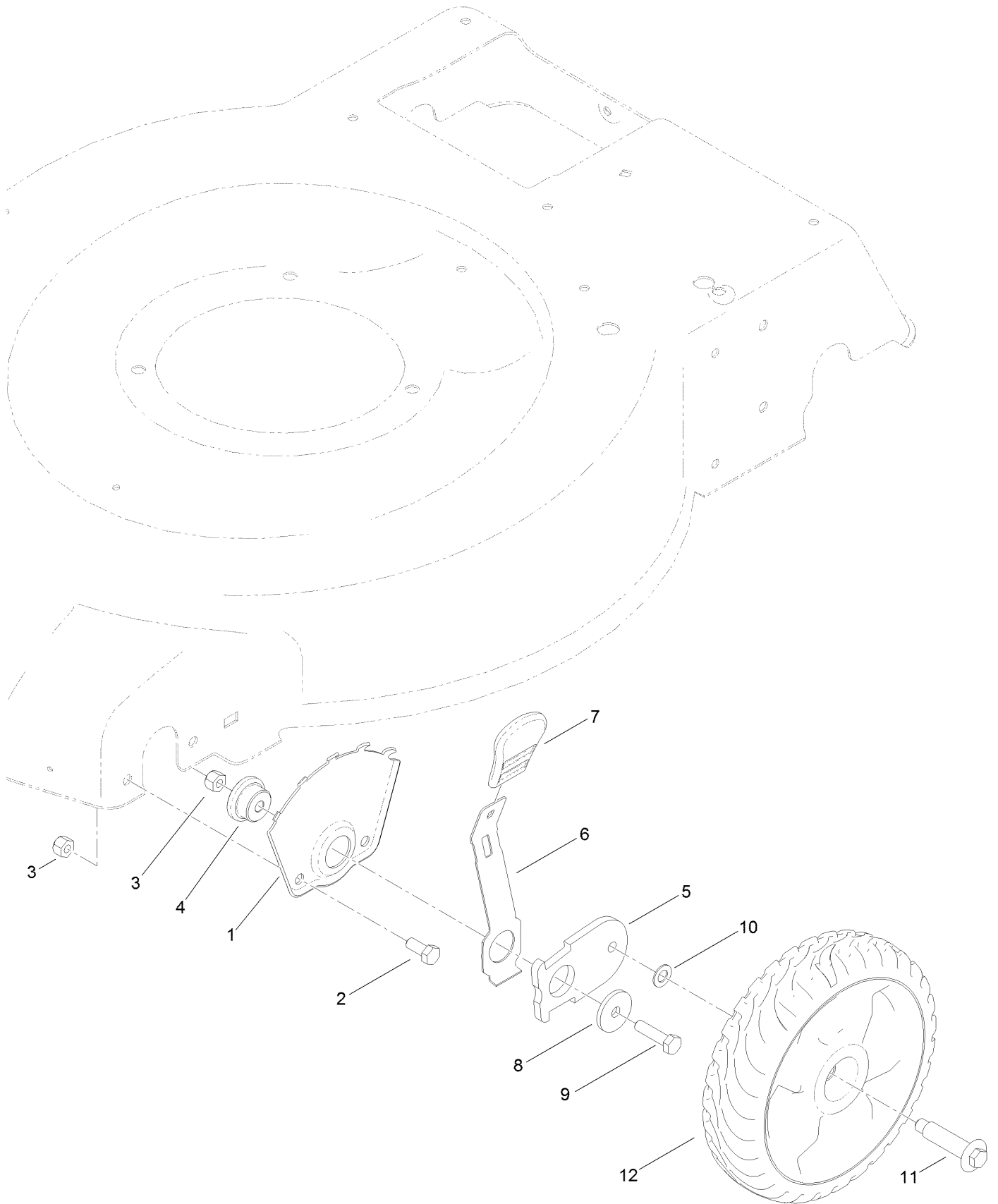

Front Wheel and Height-of-Cut Assembly (continued)

<i>Ref.</i>	<i>Part Number</i>	<i>Qty.</i>	<i>Description</i>	<i>Ref.</i>	<i>Part Number</i>	<i>Qty.</i>	<i>Description</i>
1	115-1956-03	2	Plate-HOC, Front	7	110-0549	2	Knob-HOC
2	322-3	4	Screw-HH	8	105-3048	2	Washer-Flat
3	3296-29	6	Nut-Lock, NI	9	322-6	2	Screw-HH
4	105-1818	2	Bushing-Mount, HOC	10	40-1940	2	Washer
5	105-1807	2	Arm-Pivot, Front	11	614650	2	Bolt-Shoulder
6	105-1809	2	Arm-Spring	12	115-2894	2	8 Inch Wheel ASM

Transmission and Rear Wheel Drive Assembly

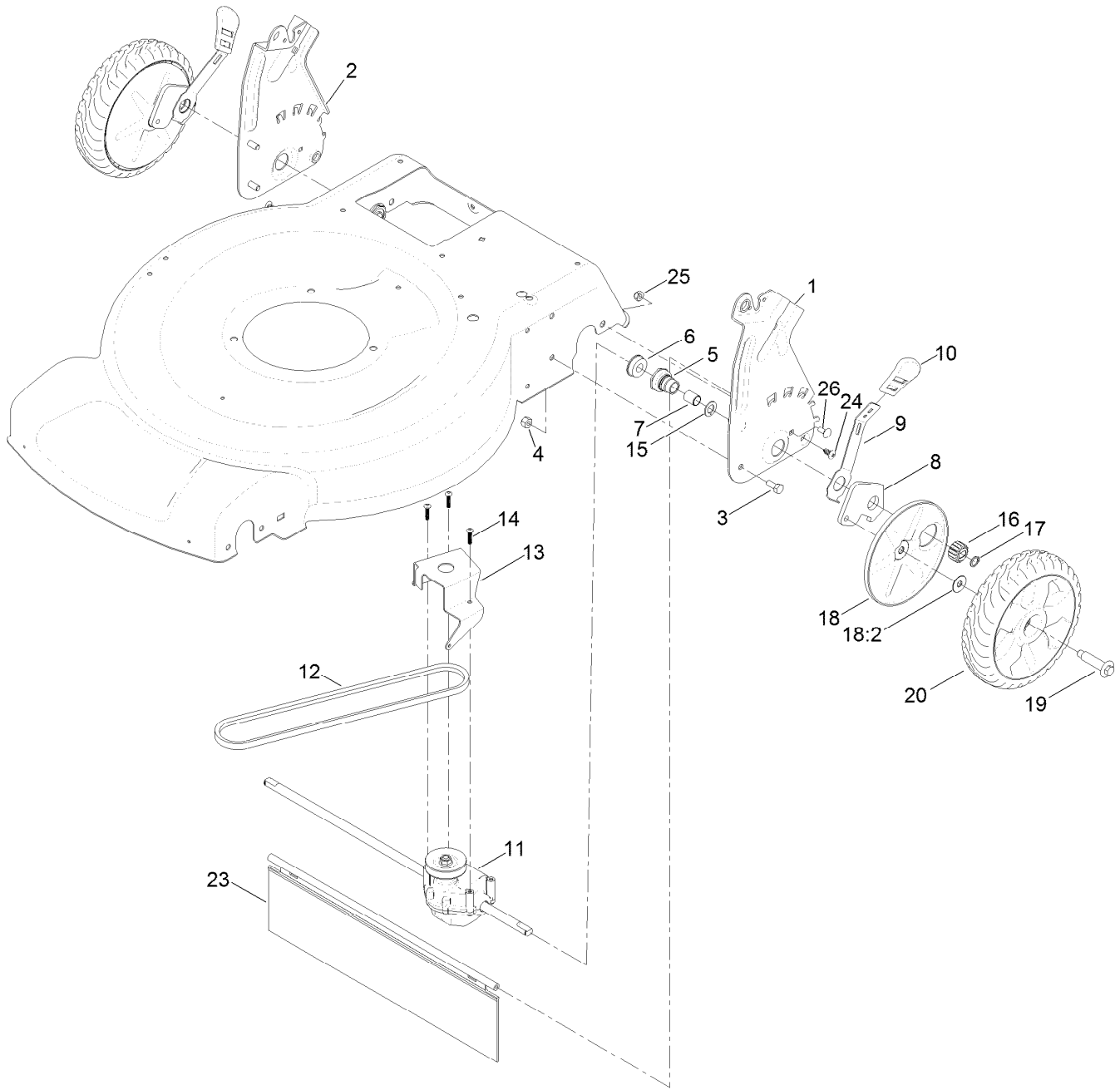

Transmission and Rear Wheel Drive Assembly (continued)

<i>Ref.</i>	<i>Part Number</i>	<i>Qty.</i>	<i>Description</i>	<i>Ref.</i>	<i>Part Number</i>	<i>Qty.</i>	<i>Description</i>
1	127-6877-03	1	Plate-Rear, LH (HOC)	14	108-7476	3	Screw-Plastite
2	127-6878-03	1	Plate-Rear, RH (HOC)	15	110-7191	2	Washer-Thrust
3	322-3	4	Screw-HH	16	110-9417	2	Gear-Pinion, 15T
4	3296-29	4	Nut-Lock, NI	17	32151-61	2	Ring-Retaining
5	108-9779	2	Retainer-Bushing, HOC	18	110-1792	2	Wheel Cover ASM
6	104-8699	2	Bearing-Ball	18:2	614426	1	Washer-Stepped
7	108-9782	2	Bushing-Sleeve	19	614650	2	Bolt-Shoulder
8	108-9781	2	Arm-Pivot, Rear	20	119-3822	2	8 Inch Wheel Gear ASM
9	108-9780	2	Arm-Spring	23	120-7012	1	Shield-Trailing
10	110-0549	2	Knob-HOC	24	117-1092	2	Screw-PTH
11	121-9178	1	Transmission	25	3229-11	2	Screw-CARR
12	115-4669	1	Belt-V	26	3296-16	2	Nut-Lock, NI
13	114-7977-03	1	Bracket-Transmission				

Upper Handle Assembly

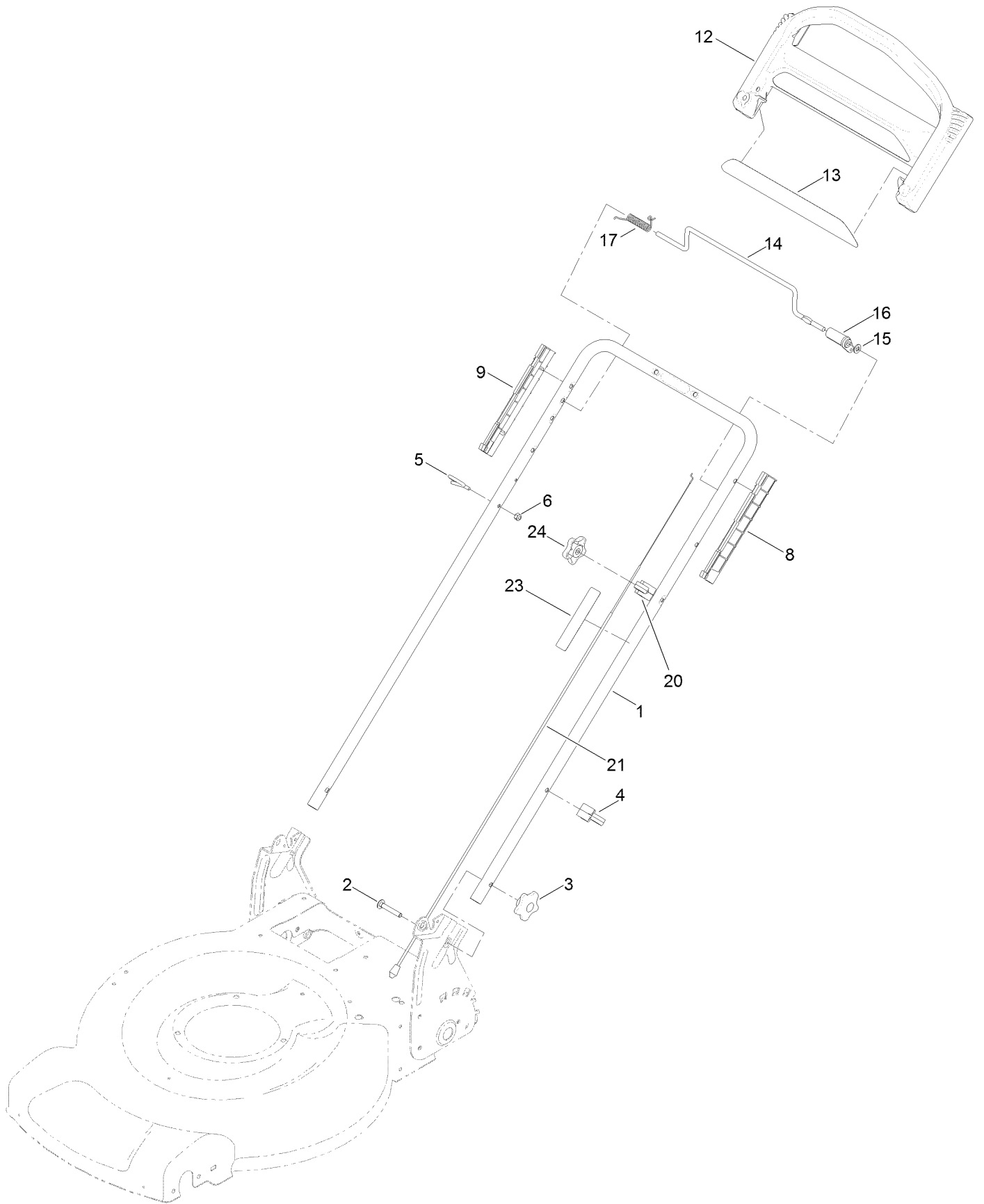

Upper Handle Assembly (continued)

<i>Ref.</i>	<i>Part Number</i>	<i>Qty.</i>	<i>Description</i>	<i>Ref.</i>	<i>Part Number</i>	<i>Qty.</i>	<i>Description</i>
1	119-3810-05	1	Handle	13	120-3911	1	Decal-Handle
2	3230-6	2	Screw-CARR	14	99-1588	1	Bar-Control, Traction
3	117-5976	2	Knob-Handle	15	3256-23	1	Washer-Flat
4	114-7988	1	Guide-Cable	16	99-1589	1	Lever-Traction
5	86-9671	1	Guide-Rope	17	121-9118	1	Spring-Torsion
6	3296-73	1	Nut-Lock, NI	20	99-5239	1	Anchor-Cable
8	105-6842	1	Guide-LH	21	115-8435	1	Cable-Traction
9	105-6841	1	Guide-RH	23	131-0894	1	Decal-Traction, Adjust
12	104-8678	1	Handle-Control	24	131-0897	1	Knob-Handle, Locking

Upper Handle Component Assembly

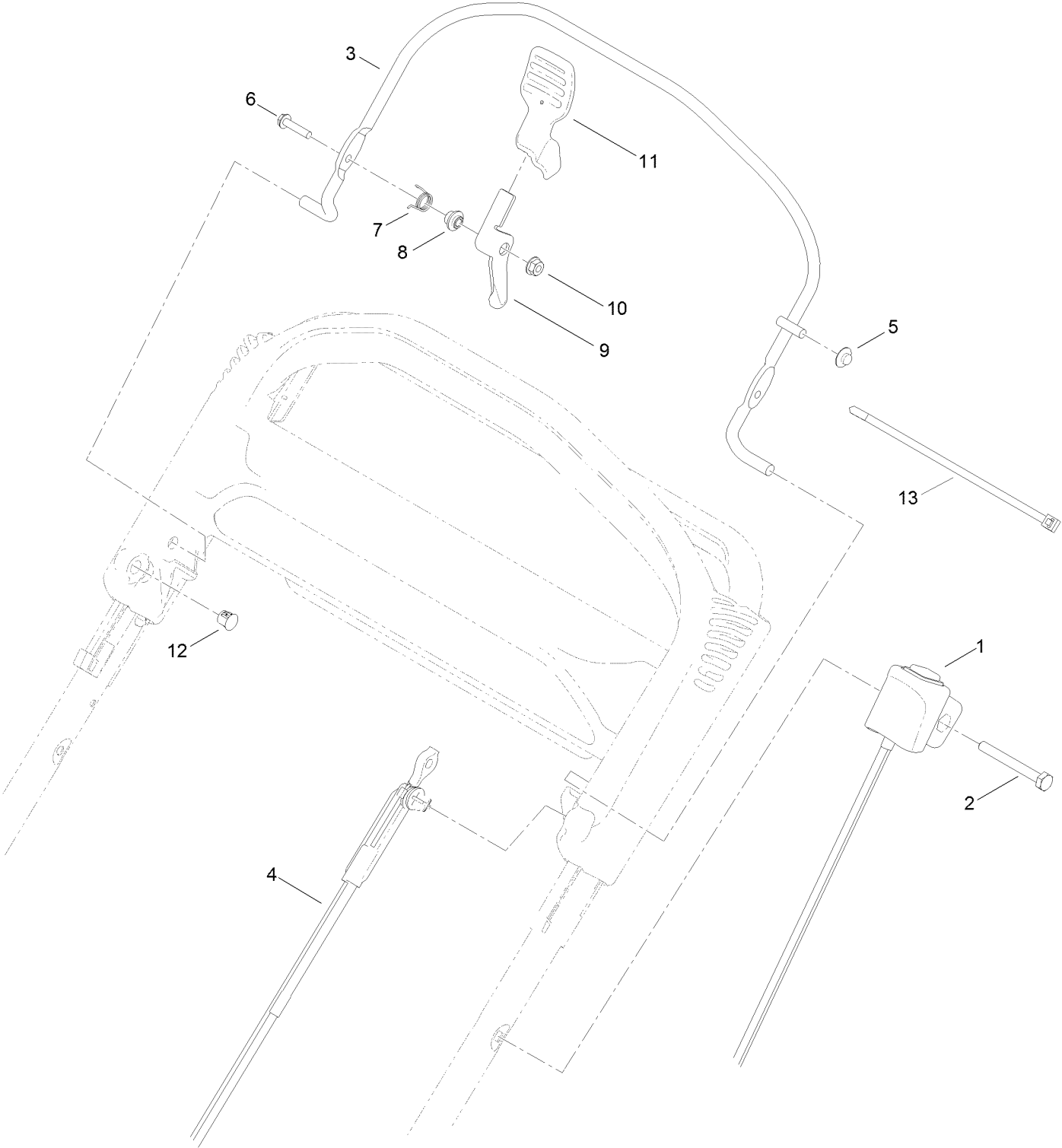

Upper Handle Component Assembly (continued)

<i>Ref.</i>	<i>Part Number</i>	<i>Qty.</i>	<i>Description</i>	<i>Ref.</i>	<i>Part Number</i>	<i>Qty.</i>	<i>Description</i>
1	117-5975	1	Switch Housing ASM	8	107-7463	1	Spacer
2	321-50	1	Screw-HH	9	106-6802	1	Lever
3	108-3788-03	1	Bail-Brake	10	32128-17	1	Nut-Lock, Flange
4	115-8439	1	Cable-Brake, BBC	11	112-8884	1	Knob-BBC
5	3290-337	1	Nut-Speed	12	104-9368	1	Plug-Dome
6	106-9169	1	Screw-HWH	13	614249	2	Tie-Cable
7	107-7462	1	Spring-Torsion				

Attachments and Accessories

For 20958 55cm Recycler Lawn Mower

Product Name	Model/Part
Traction Assist Handle Kit.....	108-8120
Lawn Striping Kit with 22in Roller, Walk-Behind Lawn Mowers	20601
Replacement Bag	59310
Replacement Frame and Bag Kit.....	59312
22in Atomic Blade.....	59534P

Notes:



Count on it.