

**TORO**<sup>®</sup>

MODEL NO. 20705-9000001 THRU 1000001 & UP

**OPERATOR'S  
MANUAL**

**21 (0.533 m) REAR BAGGER**

FINGERTIP START, SELF-PROPELLED



# FOREWORD

The Rear Bagger, a most innovative walk power mower, provides a new degree of mowing efficiency and convenience. If the mower is set up, operated and maintained properly, it will give long, dependable service.

To familiarize yourself with safety, set-up, operating and maintenance instructions, read this manual thoroughly. The major sections of this manual are:

- |                        |                           |                     |
|------------------------|---------------------------|---------------------|
| 1. Set-up Instructions | 3. Controls               | 5. Maintenance      |
| 2. Before Operating    | 4. Operating Instructions | 6. Trouble Shooting |

Safety, mechanical, and some general information in this manual is emphasized. DANGER, WARNING, and CAUTION identify the safety messages. Whenever the safety symbol appears, it is followed by a safety message; therefore, refer to the safety instructions attached to your mower for complete details. IMPORTANT identifies special mechanical information and NOTE identifies general information worthy of special attention.

## TABLE OF CONTENTS

Identification and Ordering . . . . .	2	Maintenance . . . . .	9
Loose Parts . . . . .	2	Lubricating Wheel Bearings . . . . .	9
Set-Up Instructions . . . . .	3	Lubricating Axle Pivots . . . . .	9
Install Handle . . . . .	3	Servicing Air Cleaner . . . . .	9
Before Operating . . . . .	3-4	Replacing Spark Plug . . . . .	10
Fill Crankcase With Oil . . . . .	3	Draining Petrol . . . . .	10
Fill Fuel Tank With Petrol . . . . .	3-4	Changing Crankcase Oil . . . . .	11
Controls . . . . .	4	Inspecting Cutter Blade For Damage:	
Operating Instructions . . . . .	5-8	Sharpening or Replacing . . . . .	11
Adjust Height-of-Cut . . . . .	5	Cleaning Mower Housing . . . . .	12
Starting and Stopping the Engine . . . . .	5	Adjusting Throttle Control . . . . .	12
Traction System Operation . . . . .	6	Adjusting Ground Speed Control . . . . .	1
Operating Characteristics and Tips . . . . .	6	Preparing Mower For Storage . . . . .	13
Bagging . . . . .	7	Trouble Shooting . . . . .	14-15
Mowing Without the Bag . . . . .	8		
Using Wash-Out Port . . . . .	8		

## IDENTIFICATION AND ORDERING

### MODEL AND SERIAL NUMBERS

The Rear Bagger has two identification numbers: a model number and a serial number. The two numbers are stamped into a decal located at rear of the mower housing, near the discharge door. In any correspondence concerning the mower, supply model and serial numbers to assure correct information and replacement parts are obtained.

To order replacement parts from an Authorized TORO Service Dealer, supply the following information:

1. Model and serial number of the mower.

**Note:** Do not order by reference number if a parts catalog is being used; use the PART NUMBER.

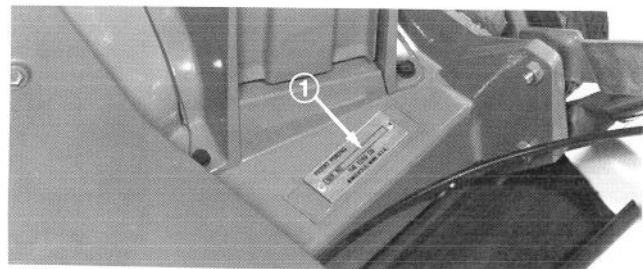

1. Model and serial number decal

## LOOSE PARTS

PART	QTY	WHERE USED
Bag	1	Assemble to mower.
Operator's Manual	1	Read manual before operating mower.

# SET-UP INSTRUCTIONS

## INSTALL HANDLE

1. Lift upper handle and align with lower handle (Fig. 1). Do not damage control cables.



Figure 1

- |                 |                 |
|-----------------|-----------------|
| 1. Upper handle | 3. Knob         |
| 2. Bag assembly | 4. Lower handle |

2. Loosen and remove each knob and curved head handle bolt, one side at a time. Be sure control cables are to rear and inside of handles (Fig. 2).

Align handle latch hole with holes in upper and lower handle and install handle bolt and knob with knobs on the outside of handle (Fig. 2).

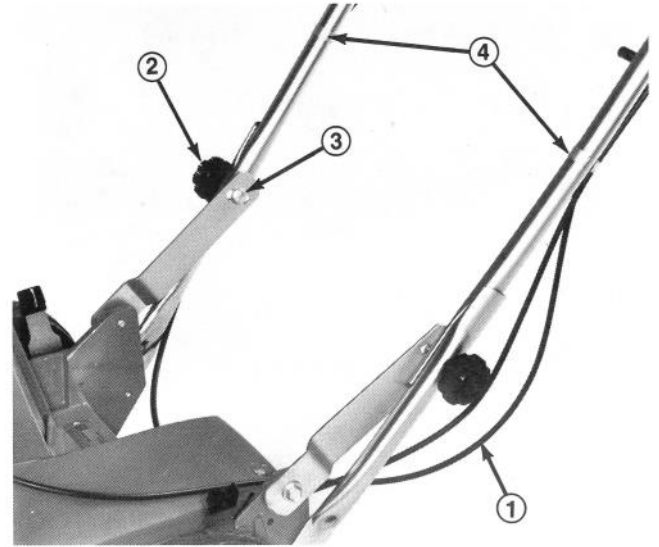

Figure 2

- |                   |                            |
|-------------------|----------------------------|
| 1. Control cables | 3. Curved head handle bolt |
| 2. Knob           | 4. Cable clips             |

3. Adjust handle height if desired.

## BEFORE OPERATING

### FILL CRANKCASE WITH OIL

Before engine is started for the first time:

1. Position mower on level surface.
2. Remove the dipstick (Fig. 3).

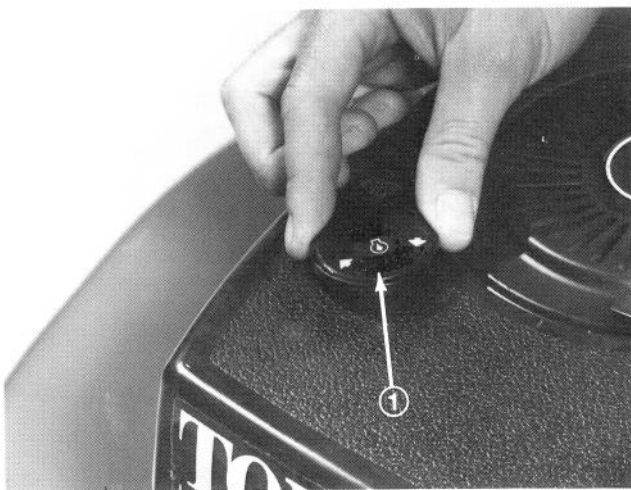

Figure 3

1. Dipstick

3. Fill with approximately 0.621 l of oil.

**Note:** Use SAE 10W-30 or 10W-40.

4. Check oil level and replace dipstick.

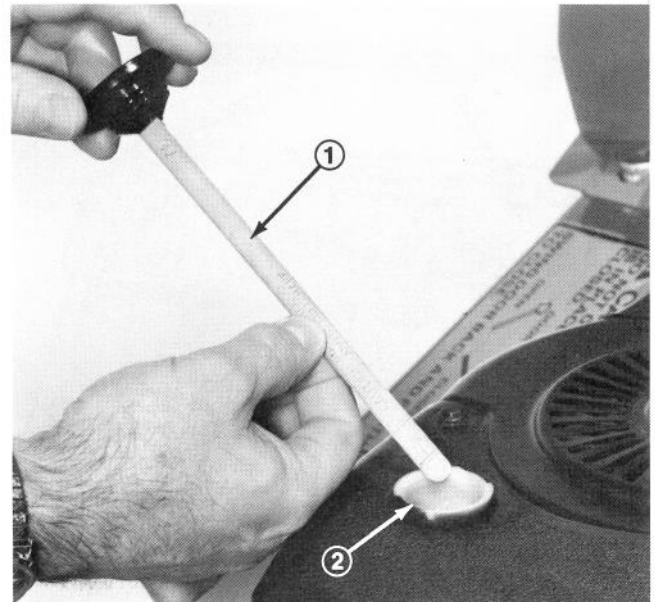

Figure 4

- |                |
|----------------|
| 1. Dipstick    |
| 2. Filler hole |

### FILL FUEL TANK WITH PETROL

1. Remove cap from fuel tank (Fig. 5).

# BEFORE OPERATING



Figure 5

1. Fuel tank cap
2. Fuel tank

2. Fill fuel tank with regular petrol. Replace fuel tank cap.
3. Wipe up spilled petrol.

# CONTROLS

**Throttle Control** (Fig. 6) – The throttle control is used to stop the engine and control blade speed. Moving the throttle forward increases engine speed and moving it backward decreases engine speed.

**Ground Speed Control** (Fig. 6) – The ground speed control has four positions: NEUTRAL (N), LOW (1), MEDIUM (2) and HIGH (3). Positioning lever in different gear settings changes ground speeds of mower.



Figure 6

1. Throttle control
2. Ground speed control
3. Traction control handle

**Traction Control Handle** – The traction control handle engages and disengages the ground speed

control unit. With engine running and ground speed control in gear, traction is accomplished by moving the handle forward. Variable speeds are available depending on gear selection and position of the traction control handle.

**Recoil Starter** (Fig. 7) – Pull fingertip starter to start the engine.



Figure 7

1. Recoil starter

**Height-of-Cut Adjusters** (Fig. 8) – The height-of-cut adjuster controls the height of the mower for cutting.

# OPERATING INSTRUCTIONS

## ADJUST HEIGHT-OF-CUT

The height-of-cut is adjustable from approximately 25 mm to 76 mm, in 13 mm increments, and letters cast into the housing represent each graduated increment (Fig. 8).

- A = 25 mm
- B = 38 mm
- C = 51 mm
- D = 64 mm
- E = 76 mm

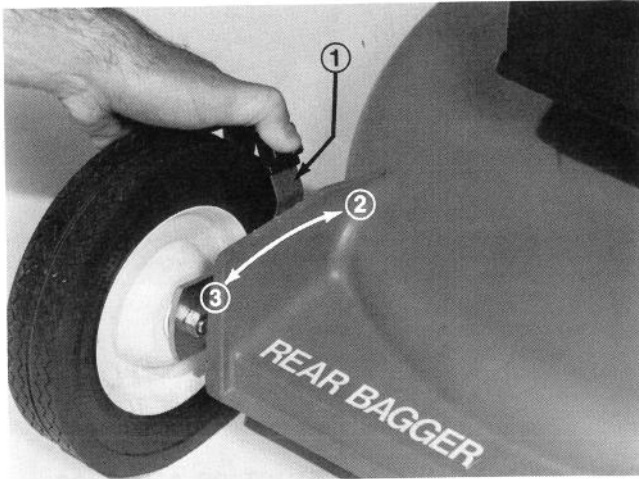

Figure 8

1. Height-of-cut adjuster
2. Low
3. High

1. **⚠** Be sure engine is not running.
2. Place thumb against height-of-cut adjuster and fingers on outside of wheel (Fig. 8).
3. Raise mower housing until wheel is off the ground. Squeeze height-of-cut adjuster toward wheel so its locating pin disengages notch in mower housing. Then pivot the wheel and adjuster to the desired height-of-cut and release adjuster so locating pin engages notch in housing.
4. To adjust to 12.7 mm setting on front wheels, rotate height-of-cut adjuster rearward past "A" until pin engages hole in housing.

## STARTING/STOPPING THE ENGINE

1. Move throttle control forward to FAST position (Fig. 9) and the ground speed control to the N (NEUTRAL) position.

Place foot on step at left side of mower housing (Fig. 10). Pull fingertip starter handle up until positive engagement results; then pull vigorously to start the engine.

3. After engine starts, move throttle control to the desired speed.

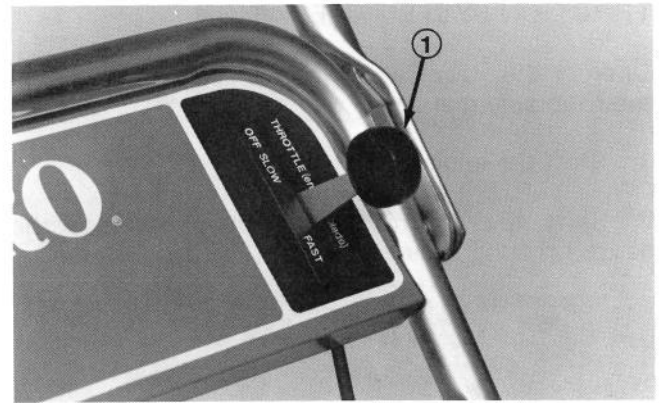

Figure 9

1. Position throttle control



Figure 10

1. Recoil starter

4. To stop engine, move throttle control to OFF position (Fig. 11).



Figure 11

1. Throttle control

# OPERATING INSTRUCTIONS

## TRACTION SYSTEM OPERATION

Operate the Rear Bagger traction control system in the following manner:

1. Start the engine.
2. Shift the ground speed control lever to the desired ground speed selection (Fig. 12).



Figure 12

1. Ground speed control

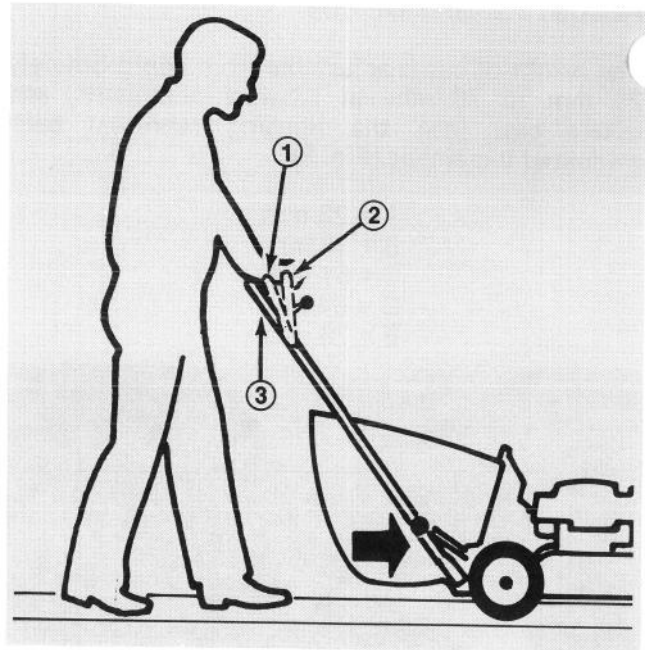

Figure 14

1. Variable ground speeds
2. Full ground speed
3. Disengage

3. Move the traction control handle forward to achieve traction operation (Fig. 13). Mower ground speed, dependent upon speed allowed by gear selection, will increase as traction handle is pushed further forward. To stop traction operation, move the traction control handle rearward to the DIS-ENGAGE position. To move mower in reverse direction, pull back on the traction control handle.



Figure 13

1. Traction control

## OPERATING CHARACTERISTICS AND TIPS

The Rear Bagger has a 164 cc engine that delivers the blade turning force necessary to produce a good quality of cut.

The mower can be used with or without the grass bag: refer to Bagging, page 7 and Mowing Without the Bag, page 8. Bagging can be accomplished by opening the chute door in the mower housing when bag is installed. Mulching is done by mowing with the chute door closed, with or without the bag installed.

To use the mower for bagging grass, install the bag, open the chute door in mower housing and start the engine. Notice that the grass bag expands at the sides and top. This expansion by the bag is caused by the air currents, generated by the blade, flowing through the bag. As grass is cut and discharged into the 0.088 m<sup>3</sup> bag, the air currents through the bag decrease gradually as it is being filled. While the bag is expanded, grass can be cut. Stop the engine and empty the bag when expansion of the bag has discontinued.

The mower is equipped with a rear shield (Fig. 15), which helps protect from objects that might be thrown rearward and from possible contact with the blade. Because of its flexible design, maneuverability of the mower is unaffected. Never remove the rear shield because it is a safety device, designed for your protection. If the shield is ever damaged, replace it before operating the mower.

After the mower is used, it must be cleaned and maintained so it is ready for the next cutting. Use

# OPERATING INSTRUCTIONS

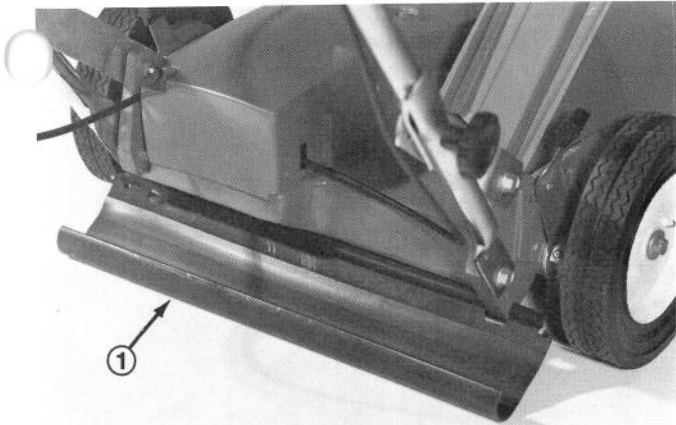

Figure 15  
1. Rear shield

the wash-out port to clean the underside of the mower housing. However, avoid getting water directly onto the engine or electrical connections because damage could result. Frequently check the air cleaner and blade, and be sure the blade bolt is tightened to 68 N·m. The oil in the crankcase must be changed after the first 2 hours of operation and after every 25 hours thereafter. Be sure level of oil is always in the SAFE range, as shown on the dipstick; however, never fill oil over the FULL mark because engine damage could result.

Whenever the mower is being operated, adjusted or maintained, the safety instructions attached to your mower must be kept in mind. Safe operation is your responsibility.

## BAGGING

The Rear Bagger discharges grass clippings into a large 0.088 m<sup>3</sup> bag, and because of the rear bagging feature, both sides of the mower can be used for trimming. Bagging is most effective when engine is running at maximum speed and only about 1/3 of grass blade is being cut. If an excessive amount of grass is being cut off, the mower can plug and cause the engine to stall. If long grass must be cut, adjust mower to the highest height-of-cut; then cut the grass. Follow this by lowering the height-of-cut and cutting the grass again.

To bag the grass with the mower:

1.  Be sure engine is not running.
2. Be sure chute door handle is fully forward and lockout lever is released into catch (Fig. 16). The chute door is now closed.
3. Slide guide hole in bag door onto locating stud on mower housing (Fig. 17); then rest rear of bag frame onto handle pins.

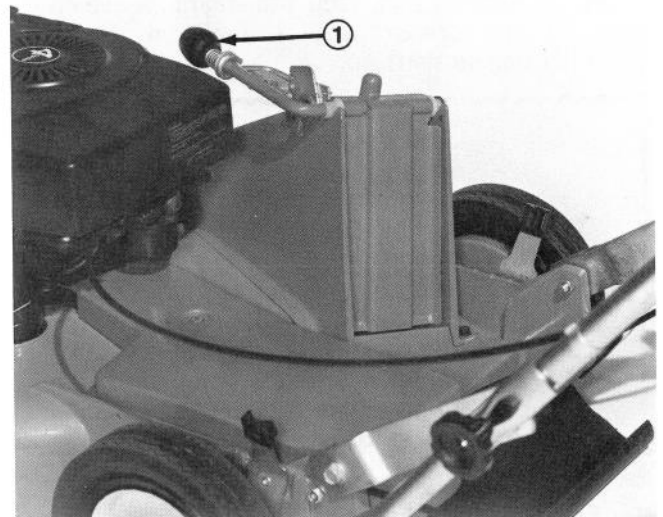

Figure 16  
1. Chute door handle

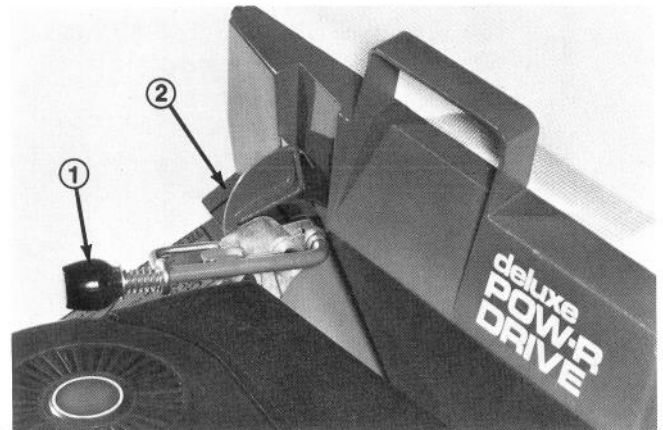

Figure 17  
1. Chute door handle  
2. Locating stud

4. Squeeze lockout lever until it clears the housing latch. Then move handle rearward until it locks in notch at rear of bag latch (Fig. 18). The chute door in mower housing is now open, and mower is ready to bag grass.

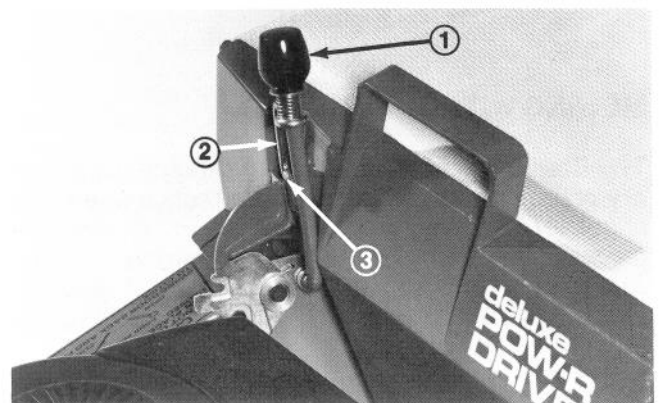

Figure 18  
1. Chute door handle  
2. Lockout lever  
3. Notch

# OPERATING INSTRUCTIONS

5. ⚠ To remove bag, stop the engine. Move chute door handle forward until it locks in the latch. Then lift bag straight up.



## CAUTION

Never open the chute door when grass bag is removed from the mower when engine is running. Grass clippings and other debris will be discharged with enough force to cause personal injury. Do not operate mower unless complete bag assembly is attached and properly positioned or rear door is completely closed.

6. To dump grass, open door at front of bag and gradually tip forward (Fig. 19).

7. Replace bag.



Figure 19

## MOWING WITHOUT THE BAG

The Rear Bagger can be used for shredding leaves or dry grass. However, this is most effective when only about 1/4 of the grass blade is cut. During this process, the blade slices the cut pieces of grass again and again, so very fine particles of grass are deposited on the lawn. These fine grass clippings eventually decompose.

To mow without the bag:

1. Squeeze lockout lever, move chute door handle

fully forward, and release lever into housing latch (Fig. 20). The chute door in mower housing is now closed, and mower is ready for mowing operation.

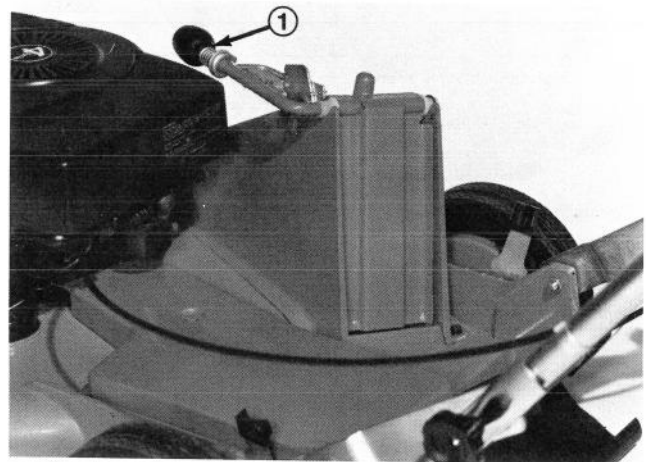

Figure 20

1. Handle forward and door closed

**Note:** If desired, the grass bag may remain on the mower.

## USING WASH-OUT PORT

After mower is used, the underside of mower housing must be cleaned.

1. ⚠ Close chute door to prevent discharge of water when wash-out port is used.
2. Set height-of-cut in the lowest position and open the wash-out port.
3. Start the engine. Insert end of hose, without nozzle, into wash-out port opening (Fig. 21). Using moderate water pressure, allow water and engine to run for approximately two minutes.

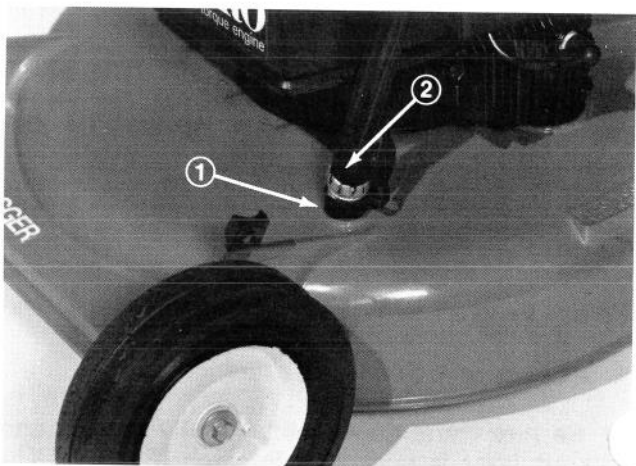

Figure 21

1. Wash-out port  
2. Hose without nozzle

# MAINTENANCE



## CAUTION

Never perform an adjustment or maintenance procedure while the engine is running. Pull high tension wire (Fig. 22) off spark plug.

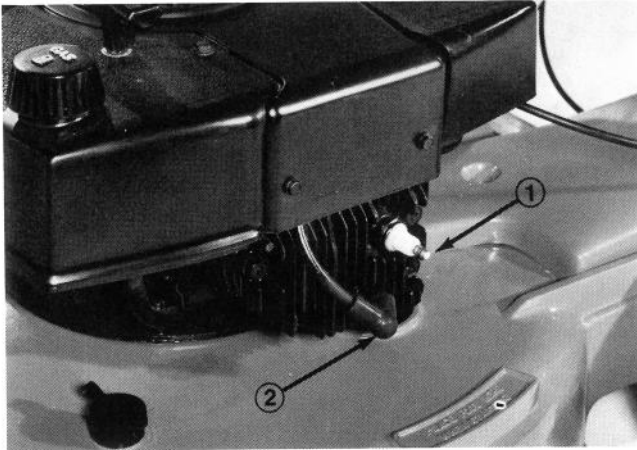

Figure 22

1. Spark plug
2. High tension wire

## LUBRICATING WHEEL BEARINGS

The front and rear wheel bearings must be greased after every 25 hours of operation, more frequently when conditions are extremely dusty or sandy.

1. Lubricate wheel bearings with No. 2 general purpose grease (Fig. 23).

**Note:** Rear wheels will spin easily in one direction only.

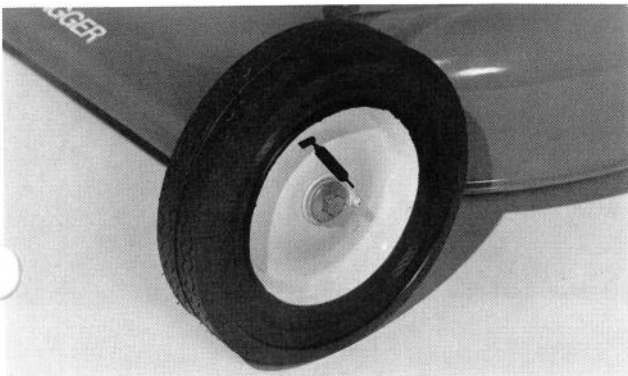

Figure 23

## LUBRICATING AXLE PIVOTS

After every 25 operating hours, to prevent premature bearing failure, grease the rear axle pivots with No. 2 Multi-Purpose Lithium Base Grease.

1. Set height-of-cut to center height-setting (C).
2. Install grease gun onto fitting and apply grease (Fig. 24). (Approximately 2-3 pumps.)
3. Wipe excess grease away and reset height-of-cut to normal setting.
4. Repeat steps 1-3 on rear pivot on opposite side.

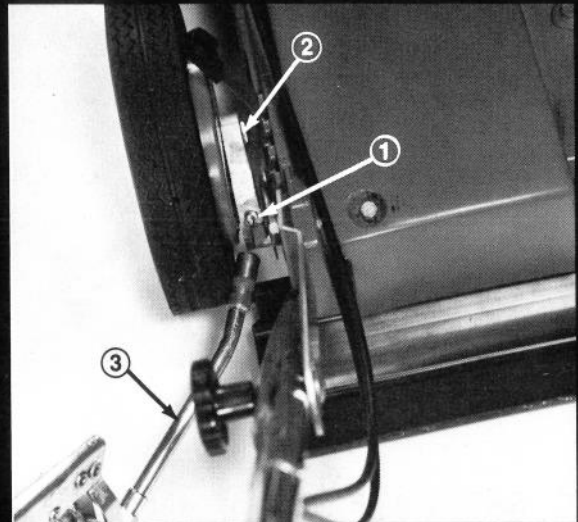

Figure 24

1. Grease fitting
2. Axle pivot
3. Grease gun

## SERVICING AIR CLEANER

The air cleaner element must be cleaned after every 25 hours of engine operation, more frequently when mower is operated in dusty or dirty conditions.

1. Remove cover and clean (Fig. 25).
2. Inspect air cleaner element (Fig. 26). If necessary remove and clean.
  - A. WASH element in a solution of liquid soap and warm water. Squeeze the element to remove dirt. Do not twist element because it may tear.
  - B. DRY the element by wrapping it in a clean rag. Squeeze the rag and element until element is dry.

# MAINTENANCE

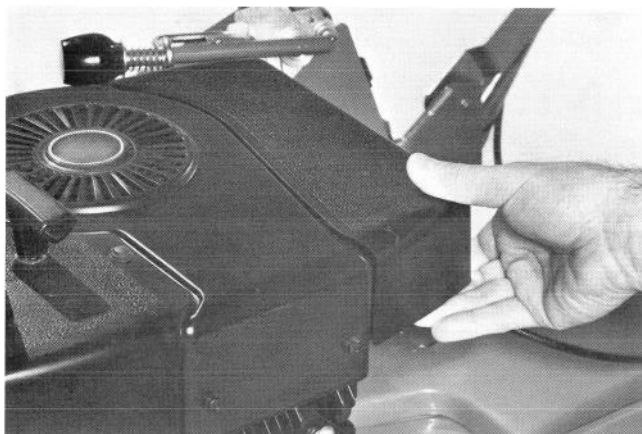

Figure 25

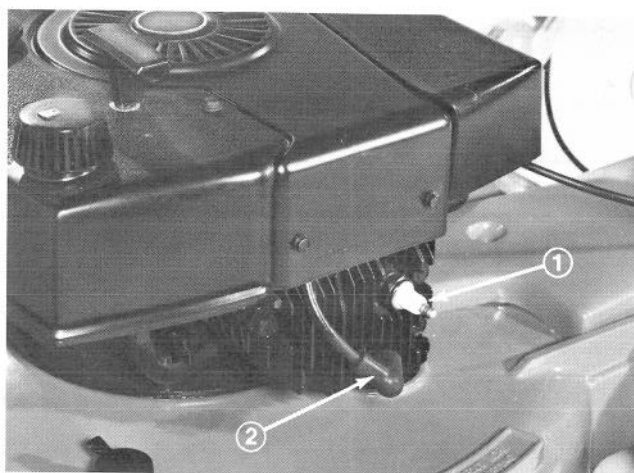

Figure 27

1. Spark plug
2. High tension wire

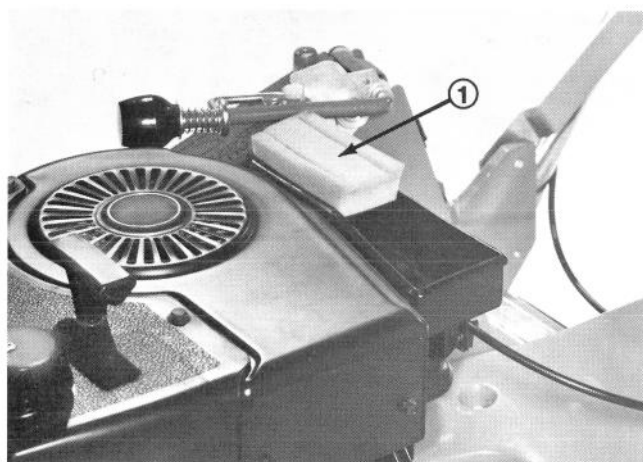

Figure 26

1. Element

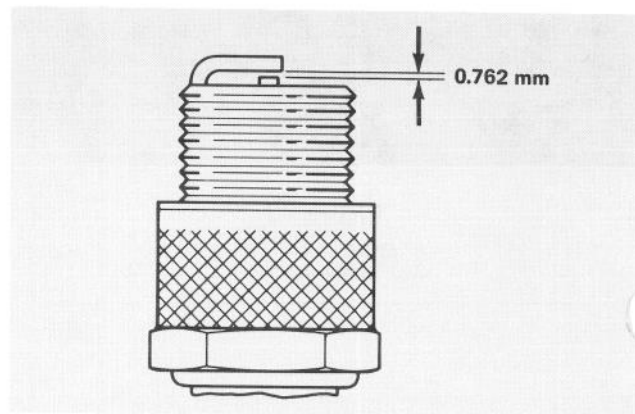

Figure 28

C. SATURATE element with engine oil. Squeeze element to remove excess oil and to distribute the oil thoroughly. A damp element is desirable.

D. Place element into the air cleaner body (Fig. 26).

3. Replace cover.

**IMPORTANT:** Do not operate engine without air cleaner element because extreme engine wear and damage will likely result.

## REPLACING SPARK PLUG

1. Remove spark plug (Fig. 27).

**IMPORTANT:** A cracked, fouled or dirty spark plug must be replaced. Recommended spark plug to use is a Champion RJ-17LM or equivalent.

2. Set air gap between electrodes at 0.762 mm (Fig. 28). Install the correctly gapped spark plug with gasket seal and tighten plug to 20.4 N·m. If torque wrench is not used, tighten plug firmly.

## DRAINING PETROL

1. Compress clip holding fuel line on fuel tank fitting (Fig. 29). Slide clip down fuel line.

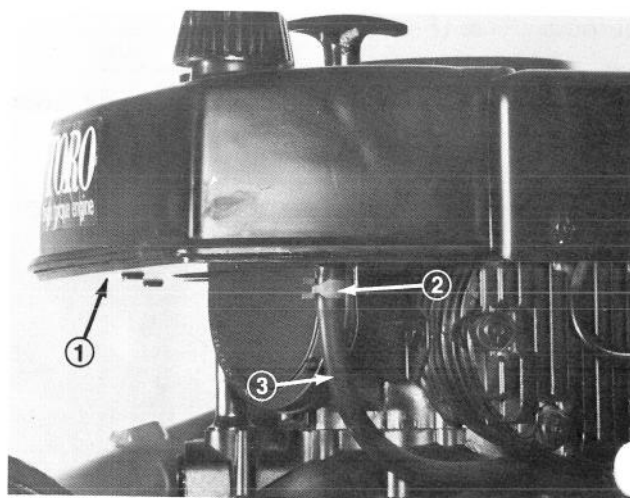

Figure 29

1. Fuel tank
2. Clip
3. Fuel line

# MAINTENANCE

2. Carefully pull fuel line off fitting to allow petrol to flow into drain pan.
3. Reinstall fuel line and clip.

## CHANGING CRANKCASE OIL

Change oil after the first 2 hours of engine operation and after every 25 hours thereafter. Since warm oil drains better and carries more contaminants than cold oil, run the engine for a minute or so before changing oil.

1. ⚠ Drain petrol from fuel tank.
2. Tip mower on its left side.
3. Remove drain plug (Fig. 30) and tip mower back to normal position to drain oil.

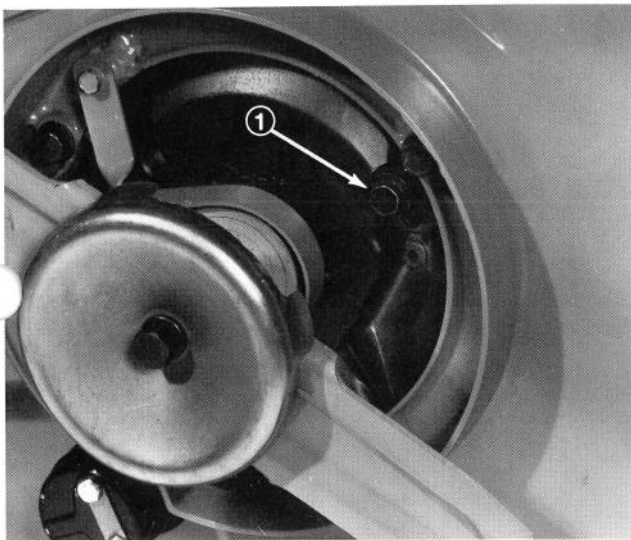

Figure 30  
1. Oil drain plug

4. After oil is drained replace oil drain plug.
5. Fill crankcase with oil.

## INSPECTING CUTTER BLADE FOR DAMAGE: SHARPENING OR REPLACING

1. ⚠ Drain gasoline from fuel tank.
2. Tip mower on its left side (Fig. 31).
3. Examine cutting ends of the blade carefully to determine whether it needs to be sharpened or replaced (Fig. 32).

To remove blade, grasp end of blade using a rag or thickly padded glove. Remove capscrew, lockwasher, scalp cup and blade (Fig. 33).

**Note:** To assure optimum cutting performance, install a new blade at the start of the cutting

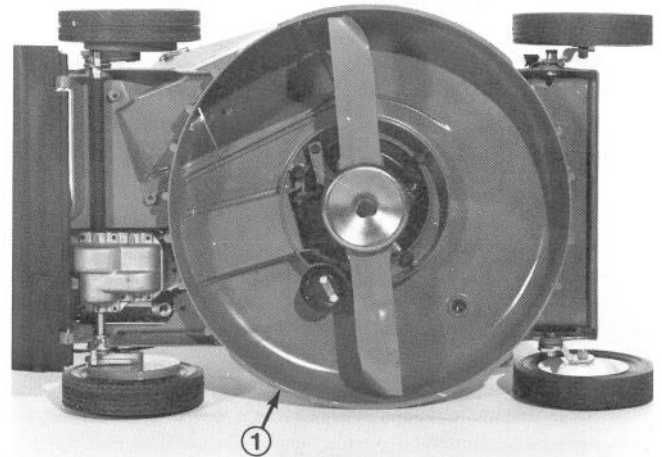

Figure 31  
1. Mower tipped on left side

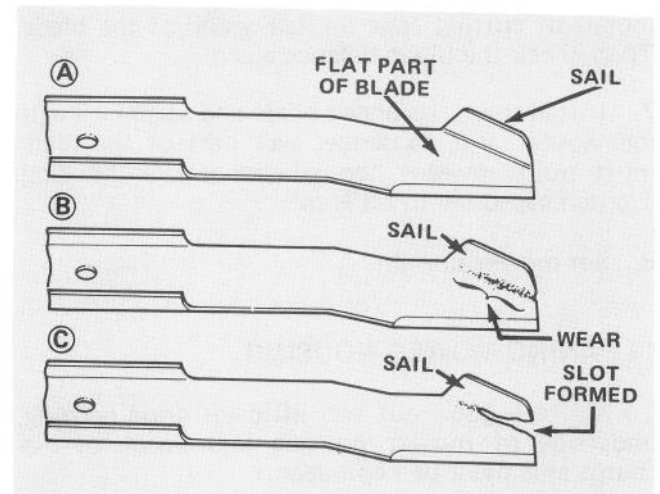

Figure 32

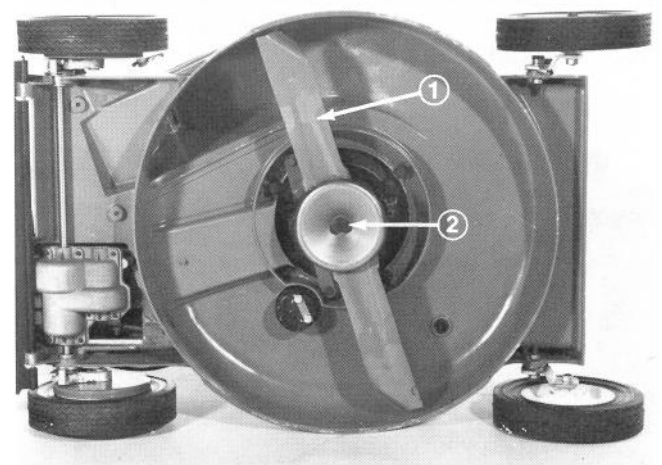

Figure 33  
1. Blade  
2. Capscrew, lockwasher and anti-scalp cup

season. During the year, file down small nicks to maintain a fine cutting edge.

# MAINTENANCE

5. Using a file, sharpen cutting edge at both ends of the blade (Fig. 34).

**IMPORTANT:** Sharpen top side of blade and maintain original cutting angle (Fig. 34).

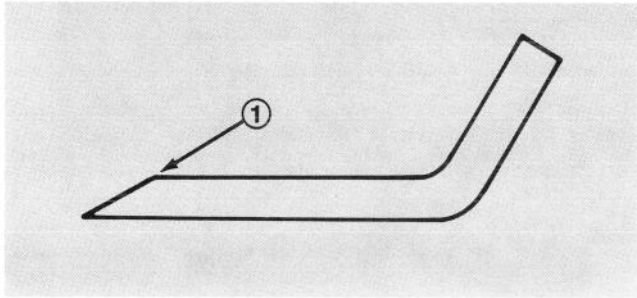

Figure 34

1. Sharpen at this angle only

6. Check balance of blade by putting it on a blade balancer. If blade is not balanced, file more metal off cutting edge on heavy end of the blade. Then check the blade balance again.

7. Install sharp, balanced blade and scalp cup with lockwasher and capscrew. Sail part of the blade must point toward top of the mower housing. Tighten capscrew to 68 N·m.

8. Set mower upright.

## CLEANING MOWER HOUSING

To assure a good cut and efficient grass bagging, underside of mower housing and inside of discharge area must be kept clean.

1. ⚠ Drain petrol from fuel tank.
2. Tip mower on its left side (Fig. 35). Remove grass clippings and dirt with a garden hose or wooden scraper.

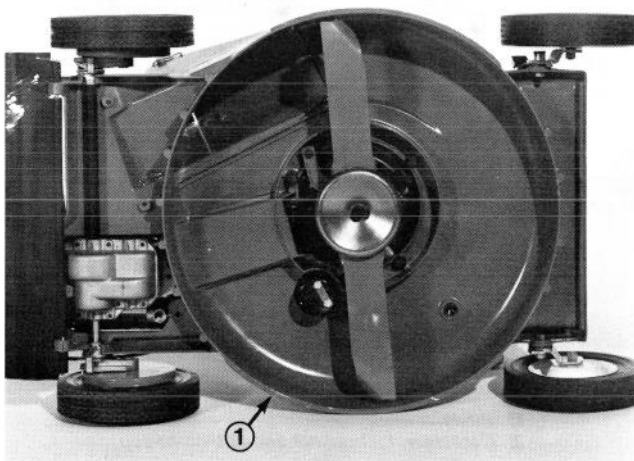

Figure 35

1. Mower tipped on left side

3. Set mower upright.

## ADJUSTING THROTTLE CONTROL

An adjustment of the throttle control may be required if the engine does not start or stop and whenever a new throttle control cable assembly is installed.

1. Move the throttle control lever to the OFF position.
2. Loosen cable clamp screw until throttle cable is free to slide (Fig. 36).

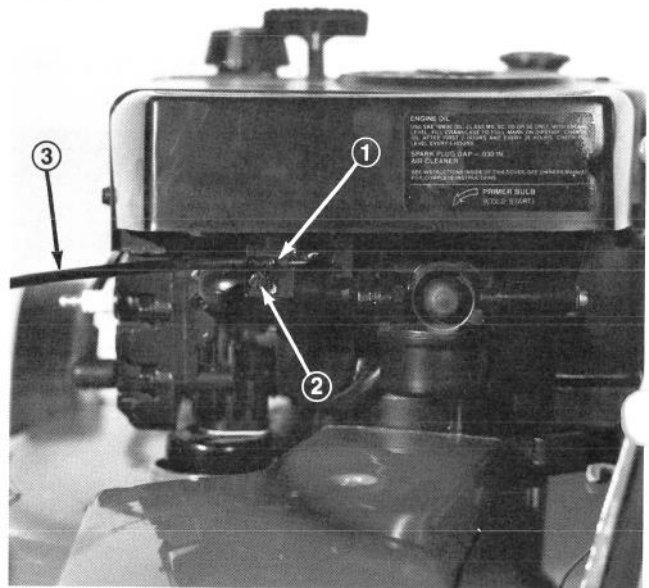

Figure 36

1. Control arm
2. Clamp screw
3. Throttle cable

3. Move carburetor control arm to the left until it contacts grounding bracket (Fig. 36). Pull throttle cable slightly to remove any slack and tighten the cable clamp screw to lock the adjustment in place.

## ADJUSTING GROUND SPEED CONTROL

1. Be sure engine is not running.
2. Close door in mower housing and remove bag.
3. Remove two capscrews securing transmission cover and remove cover (Fig. 37).
4. Loosen the capscrew securing the ground speed control cable (Fig. 38, item 1).
5. Move the ground speed control lever to N (NEUTRAL).
6. Push transmission control lever to right in direc-

# MAINTENANCE

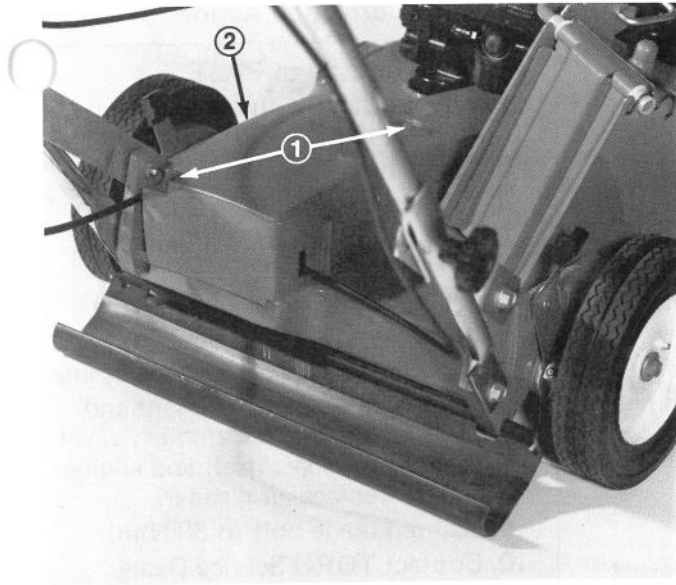

Figure 37

1. Transmission cover mounting cap screws
2. Transmission cover

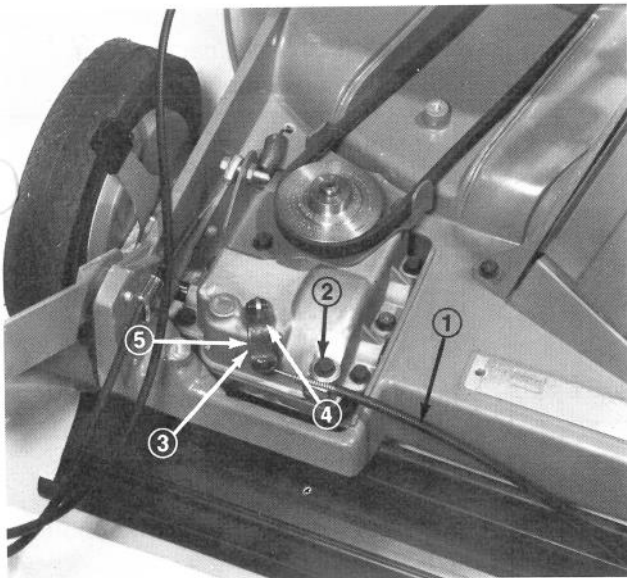

Figure 38

1. Ground speed control cable
2. Cap screw
3. Transmission control lever
4. Roll pin
5. Push towards cap screw

tion of cable clamping cap screw as far as possible, hold in position and tighten cap screw (Fig. 38).

7. Pull mower rearward with ground speed con-

trol in NEUTRAL. Mower should pull back freely without any rotation of pulley on top of gear case. If rotation of pulley occurs, adjustment for NEUTRAL is incorrect.

8. Install transmission cover.

## PREPARING MOWER FOR STORAGE

1. Drain petrol from fuel tank. Start the engine and let it run until all petrol is used.

2. Pull high tension wire off spark plug and remove plug from cylinder head. Pour 30 ml of 10W-40 oil into spark plug hole. Pull recoil starter handle slowly to distribute oil on inside of cylinder. Then install spark plug and tighten it to 20.4 N·m. If torque wrench is not used, tighten plug firmly. **DO NOT INSTALL HIGH TENSION WIRE ON SPARK PLUG.**

3. Drain oil from crankcase: do not fill crankcase with oil at this time.

4. Clean dirt and chaff from outside of cylinder, cylinder head fins, blower housing, external parts of engine, shrouding and top of mower housing.

5. Clean underside of mower housing.

6. Check condition of blade and blade cap screw; repair or replace if necessary.

7. Check and tighten all cap screws, bolts, screws, nuts and mating parts. Repair or replace if necessary.

8. Lubricate wheel bearings and rear pivot assemblies.

9. Wash the air cleaner element.

10. Fill crankcase with oil.

11. "Touch up" all chipped paint surfaces. Make sure to sand affected area before painting.

12. Store the mower in a clean, dry place. For convenience, upper handle can be folded for more compact storage. Cover the mower to protect it and keep it clean.

## TROUBLE SHOOTING

Problem	Possible Causes	Correction Action
Engine does not start.	<ol style="list-style-type: none"> <li>1. Throttle not in FAST position.</li> <li>2. Fuel tank is empty.</li> <li>3. Air cleaner element is dirty.</li> <li>4. Spark plug loose.</li> <li>5. High tension wire loose or disconnected from spark plug.</li> <li>6. Spark plug gap is incorrect.</li> <li>7. Spark plug is defective.</li> <li>8. Carburetor is flooded with petrol.</li> <li>9. Blade bolt is loose.</li> <li>10. Faulty points or condenser.</li> </ol>	<ol style="list-style-type: none"> <li>1. Move throttle to FAST.</li> <li>2. Fill fuel tank with petrol: refer to Fill Fuel Tank With Petrol.</li> <li>3. Clean air cleaner element.</li> <li>4. Tighten spark plug to 20.4 N·m.</li> <li>5. Install high tension wire on plug.</li> <li>6. Set gap between electrodes at 0.762 mm.</li> <li>7. Install new, correctly gapped plug.</li> <li>8. Remove air cleaner element and pull starter rope continuously until carburetor clears itself and engine starts. Replace air cleaner.</li> <li>9. Tighten blade bolt to 68 N·m.</li> <li>10. Contact TORO Service Dealer.</li> </ol>
Engine starts hard or loses power.	<ol style="list-style-type: none"> <li>1. Dirt or water in gas tank.</li> <li>2. Vent hole in fuel tank cap is plugged.</li> <li>3. Air cleaner is dirty.</li> <li>4. Blade bolt is loose.</li> </ol>	<ol style="list-style-type: none"> <li>1. Drain petrol and clean fuel tank. Fill tank with clean, fresh petrol.</li> <li>2. Clean or replace fuel tank cap.</li> <li>3. Clean the air cleaner element.</li> <li>4. Tighten blade bolt to 68 N·m.</li> </ol>
Engine operates erratically or idles poorly.	<ol style="list-style-type: none"> <li>1. Spark plug is defective.</li> <li>2. Spark plug gapped incorrectly.</li> <li>3. Air cleaner is dirty.</li> <li>4. Oil level in crankcase is low.</li> <li>5. Air slots in engine shroud are plugged.</li> <li>6. Cooling fins and air passages under engine blower housing are plugged.</li> </ol>	<ol style="list-style-type: none"> <li>1. Install new, correctly gapped plug: refer to Replacing Spark Plug, page 10.</li> <li>2. Set gap between electrodes at 0.762 mm.</li> <li>3. Clean the air cleaner element: refer to Servicing Air Cleaner, page 9.</li> <li>4. Add oil to crankcase: refer to Fill Crankcase With Oil, page 3.</li> <li>5. Remove obstruction from slots.</li> <li>6. Remove obstruction from cooling fins and air passages.</li> </ol>
Engine skips at high speed.	<ol style="list-style-type: none"> <li>1. Air gap between electrodes of spark plug is too close.</li> </ol>	<ol style="list-style-type: none"> <li>1. Set air gap at 0.762 mm.</li> </ol>
Engine overheats.	<ol style="list-style-type: none"> <li>1. Cooling air flow is restricted.</li> <li>2. Oil level in crankcase is low.</li> <li>3. Incorrect spark plug.</li> </ol>	<ol style="list-style-type: none"> <li>1. Remove any obstruction from slots in shroud, blower housing, air passages, and cooling fins on engine.</li> <li>2. Add oil to crankcase: refer to Fill Crankcase With Oil, page 3.</li> <li>3. Install Champion RJ-17LM spark plug that is gapped at 0.762 mm.</li> </ol>
Mower vibrates abnormally.	<ol style="list-style-type: none"> <li>1. Blade bolt is loose.</li> <li>2. Cutter blade is unbalanced.</li> </ol>	<ol style="list-style-type: none"> <li>1. Tighten blade bolt to 68 N·m.</li> <li>2. Sharpen cutter blade and check the balance: refer to Sharpening or Replacing Cutter Blade, page 11. Replace the blade if it cannot be balanced.</li> </ol>

## TROUBLE SHOOTING

Problem	Possible Causes	Corrective Action
No traction drive.	<ol style="list-style-type: none"> <li>1. Ground speed control mal-adjusted or broken.</li> <li>2. Transmission drive belt loose or broken.</li> <li>3. Traction control handle cable maladjusted or broken.</li> <li>4. Damaged wheel and pinion gear assembly.</li> <li>5. Malfunction in transmission assembly.</li> </ol>	<ol style="list-style-type: none"> <li>1. Adjust ground speed control: refer to Adjusting Ground Speed Control, page 12, or Installing Ground Speed Control, page 12.</li> <li>2. Adjust belt tension or replace belt.</li> <li>3. Adjust or replace cable.</li> <li>4. Repair as necessary.</li> <li>5. Repair as necessary.</li> </ol>
Mower creeps forward – traction control handle disengaged.	<ol style="list-style-type: none"> <li>1. Debris caught between mower housing and transmission. (Belt under tension).</li> <li>2. Traction belt over-tensioned, i.e., belt not loose enough when disengaged.</li> </ol>	<ol style="list-style-type: none"> <li>1. Remove transmission cover and clear debris away: refer to Figure 37, page 13.</li> <li>2. Relieve belt tension. Contact an Authorized Toro Service Dealer for assistance.</li> </ol>

