



Count on it.

Parts Catalog

**Z Master® Commercial 2000
Series Riding Mower**

**with 60in TURBO FORCE® Side Discharge
Mower**

Model No. 74145—Serial No. 315000001 and Up



Ordering Replacement Parts

To order replacement parts, please supply the part number, the quantity, and the description of each part desired.

Understanding Reference Numbers

Each identified part in an illustration has a reference number. The reference number for a part also appears in the parts list, along with other information about the part.

This catalog uses two special reference number formats, one to indicate parts in a service assembly and another to indicate the quantity of a given part in an illustration.

Service Assembly Reference Numbers

Parts in service assemblies have reference numbers in the form a:b. The a represents the reference number of the entire service assembly and the b represents a sequential number unique to each part within the service assembly.

For example, a wheel assembly might be identified by reference number 6, the tire by 6:1, the valve by 6:2, and the wheel by 6:3. When you order the assembly identified by reference number 6, you receive all parts identified by reference numbers 6:1, 6:2, and 6:3. However, you may also order any part individually. Reference numbers of this type appear in illustration and in parts lists.

Reference Numbers Indicating Quantity

In an illustration, if a reference number indicates more than one part, the reference number has the form nX y. The n represents the quantity of the part, the X is the multiplication symbol, and the y represents the reference number.

For example, in an illustration, the reference number 2X 37 means that two of the parts identified by reference number 37 are indicated.

List of Abbreviations

AR: as required

ASM: assembly

BBC: blade brake control

BHTF: button head thread forming

CARR: carriage

CCW: counter clockwise

CW: clockwise

DEG: degrees

DPA: Dual Point Adjustment

ECM: electronic control module

EXT: external

FH: flat head

GA: gauge

HD: heavy-duty

HF: hex flange

HH: hex head

HHF: hex head flange

HHFTF: hex head flange thread forming

HJ: hex jam

HLH: hex lag head

HOC: height-of-cut

HP: high pressure

HSBH: hex socket button head

HSFH: hex socket flat head

HSH: hex socket head

HWH: hex washer head

HWHTF: hex washer head thread forming

HYD: hydraulic

LH: left hand

LP: low pressure

LPG: Liquefied Petroleum Gas

NI: nylon insert

NPTF: national pipe thread fine

PFH: phillips flat head

PPH: phillips pan head

PPHTF: phillips pan head thread forming

PRH: phillips round head

PTH: phillips truss head

PTO: power-take-off

RH: right hand

ROPS: roll-over protection system

RRB: rear roller brush

SFH: slotted fillister head

SHH: slotted hex head

SHWH: slotted hex washer head

SPH: slotted pan head

SQH: square head

SRH: slotted round head

STD: standard

TAP: self tapping

TTH: torx truss head

Contents

Frame and Caster Wheel Assembly	4
Roll-Over Protection System Assembly No. 116-0231	6
Caster Wheel and Fork Assembly	8
Hydro Drive System Assembly	10
Hydro Idler Arm Assembly	12
RH Transaxle Assembly No. 130-2850	14
LH Transaxle Assembly No. 130-2851	16
Fuel Tank and Hose Assembly	18
Seat Mounting Assembly	20
Seat Assembly No. 127-9538	22
Motion Control Assembly	24
Parking Brake Assembly	26
Engine, Muffler and Control Panel Assembly	28
Deck Lift Assembly	30
Height-of-Cut Assembly No. 120-2530	32
Deck Assembly	34
Deck Decal Assembly No. 120-2461	36
Deflector Assembly No. 120-2451	38
Idler Assembly	40
Electrical Assembly	42
Attachments and Accessories	44

Frame and Caster Wheel Assembly

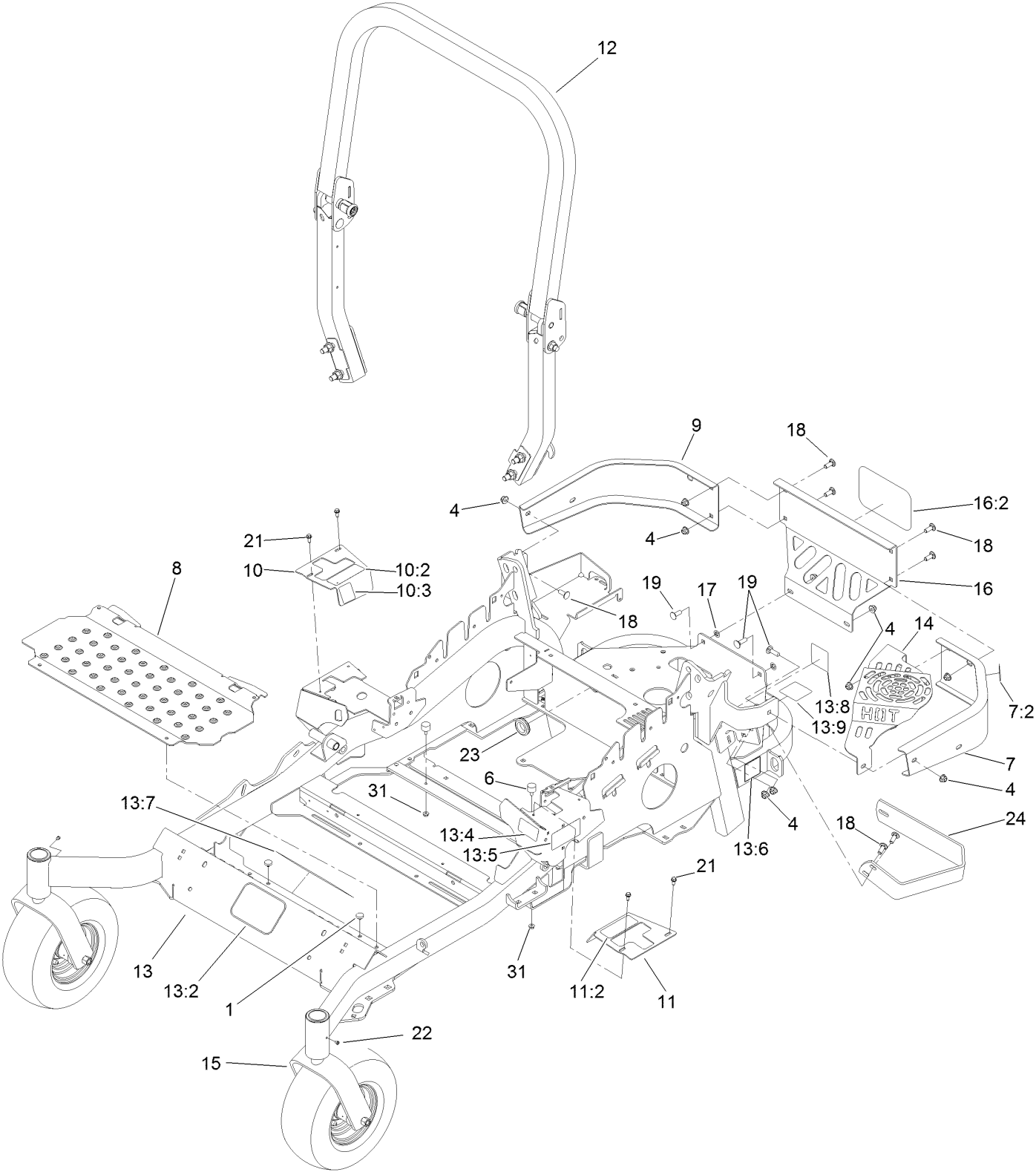

Frame and Caster Wheel Assembly (continued)

<i>Ref.</i>	<i>Part Number</i>	<i>Qty.</i>	<i>Description</i>	<i>Ref.</i>	<i>Part Number</i>	<i>Qty.</i>	<i>Description</i>
1	1-513658	2	Bumper	13:6	106-2655	2	Decal-Hazard, Pinched Finger
4	104-8301	10	Nut-Flange, NI	13:7	127-0335	1	Decal-Warning, Slope
6	116-6380	2	Bumper-Rubber (W/ Stud)	13:8	116-4858	1	Decal-Spark Arrester
7	109-9869	1	Bumper-Rear, LH	13:9	117-1158	2	Decal-Bypass
7:2	106-5517	1	Decal-Warning, Hot Surface	14	120-7896-03	1	Guard-Muffler
8	116-8898-01	1	Floorpan	15		2	Caster Wheel ASM ●
9	116-0508-03	1	Bumper-Rear, RH	16	119-2691	1	Rear Guard ASM
10	121-4780	1	RH Motion Control Cover ASM	16:2	67-7320	1	Decal
10:2	99-8936	1	Decal-Control, Motion	17	107-3154	2	Nut-Push
10:3	116-5988	1	Decal-Park Brake, Ce	18	3231-22	7	Screw-CARR
11	121-4789	1	Motion Control Cover ASM	19	3231-25	3	Bolt-CARR
11:2	99-8936	1	Decal-Control, Motion	21	32144-10	4	Screw-HWH
12	116-0231	1	ROPS ASM	22	1-811010	2	Plug
13	117-8591	1	Frame ASM	23	120-3265	1	Grommet
13:2	68-3640	1	Decal	24	119-2607-03	1	Guard-Muffler, Side
13:4	117-3864	1	Decal-Fuel Fill, Ce	31	104-7201	2	Nut-HF
13:5	120-5891	2	Decal				

● Not serviced separately

Roll-Over Protection System Assembly No. 116-0231

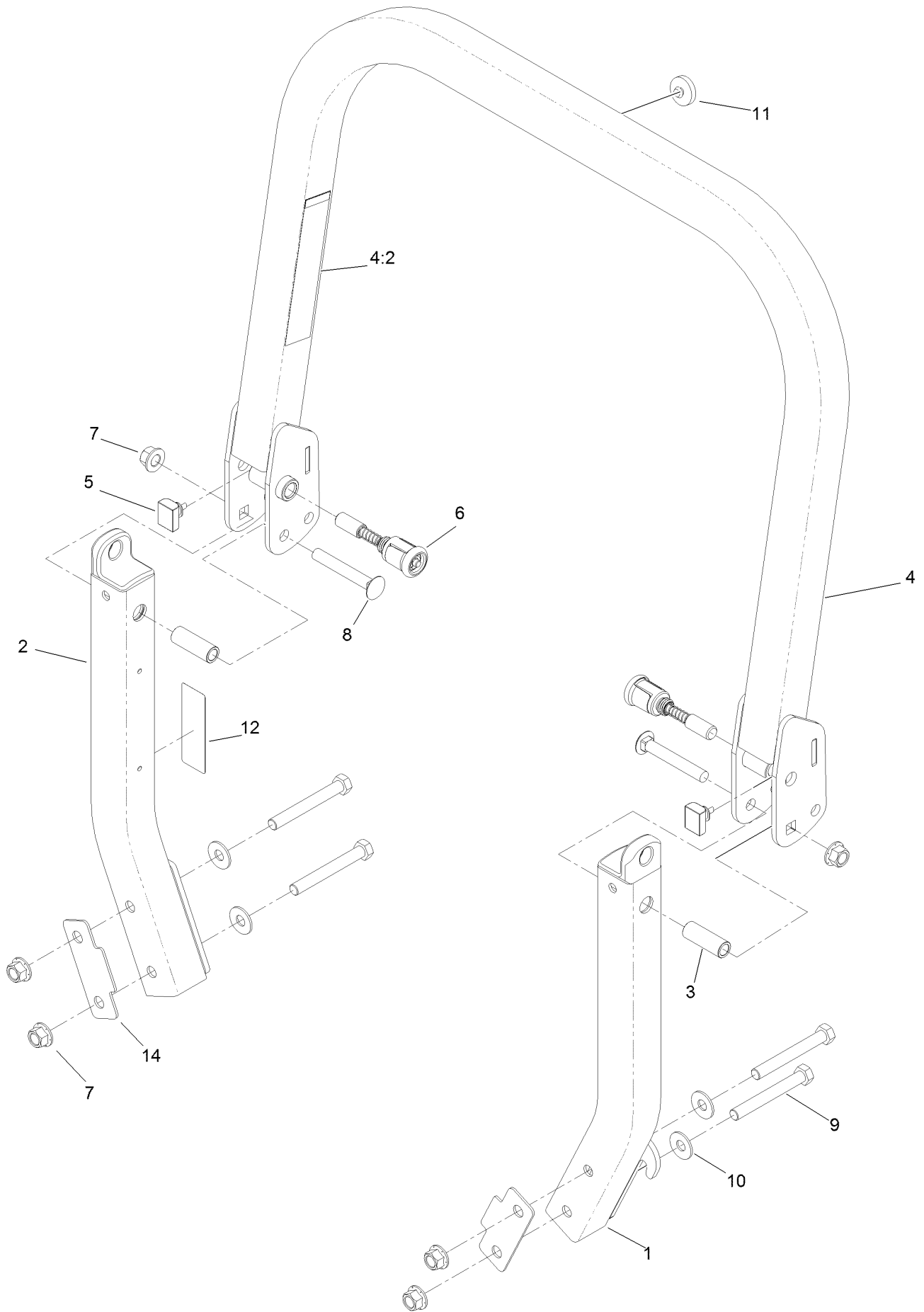

Roll-Over Protection System Assembly No. 116-0231 (continued)

<i>Ref.</i>	<i>Part Number</i>	<i>Qty.</i>	<i>Description</i>	<i>Ref.</i>	<i>Part Number</i>	<i>Qty.</i>	<i>Description</i>
1		1	Leg-ROPS, LH ●	7	99-5107	6	Nut-Lock
2		1	Leg-ROPS, RH ●	8	3233-10	2	Screw-CARR
3	109-6653	2	Spacer	9	325-35	4	Screw-HH
4		1	Upper ROPS ASM ●	10	109-9505	4	Washer-Spring
4:2	107-3069	1	Decal-Warning, Folding ROPS	11	109-9233	1	Bumper-Push-In, Rubber
5	109-5337	2	Bumper-ROPS	12	117-0346	1	Decal-Caution, Fuel Vent
6	116-0104	2	Pin-Spring	14	116-0960	2	Spacer

● Not serviced separately

Caster Wheel and Fork Assembly

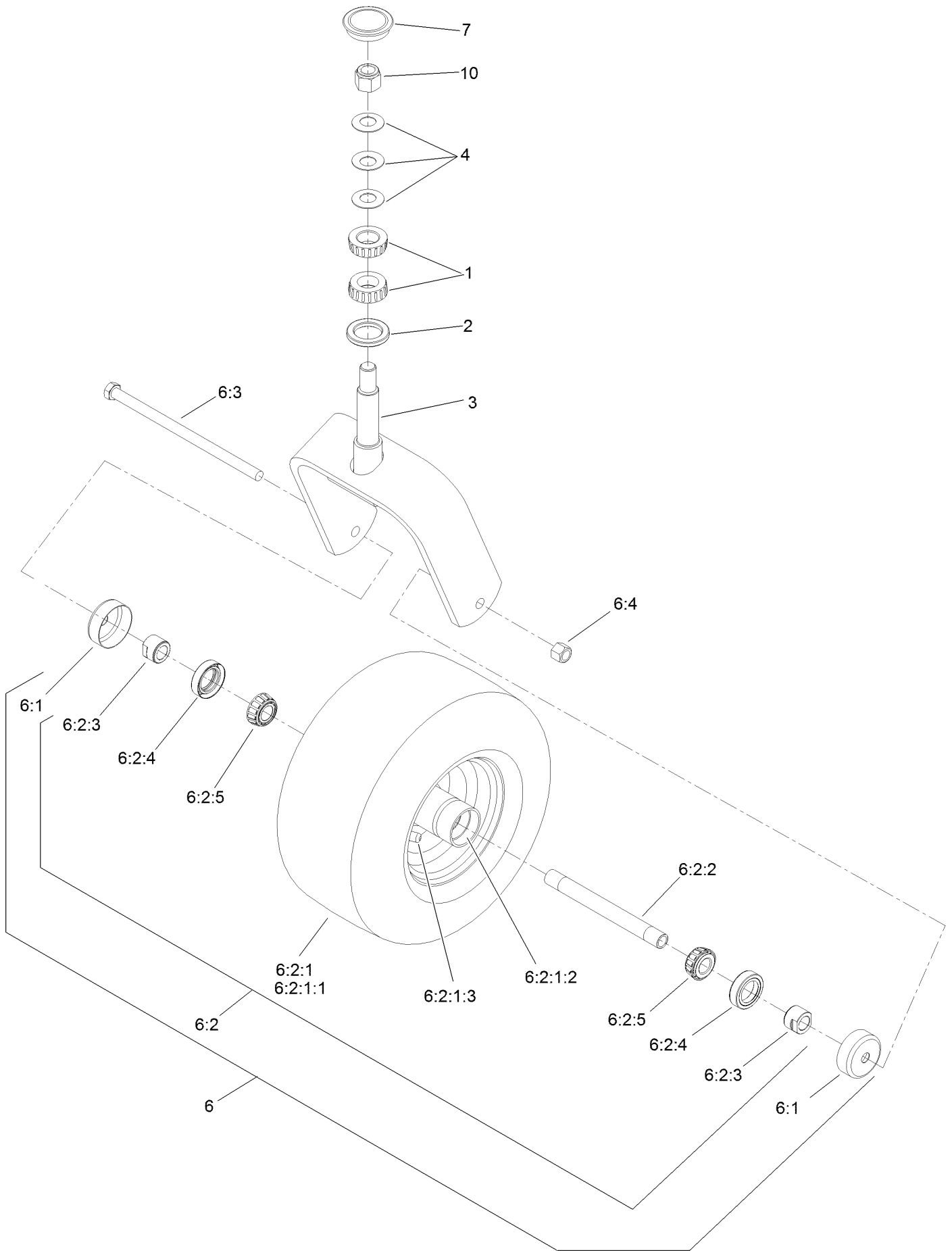

Caster Wheel and Fork Assembly (continued)

<i>Ref.</i>	<i>Part Number</i>	<i>Qty.</i>	<i>Description</i>	<i>Ref.</i>	<i>Part Number</i>	<i>Qty.</i>	<i>Description</i>
1	1-543509	2	Bearing-Roller, Tapered	6:2:1:3	5108	1	Valve
2	116-5647	1	Seal-Grease	6:2:2	103-5156	1	Axle-Caster
3	116-6707-01	1	Caster	6:2:3	103-3051	2	Spacer-Nut
4	1-633508	3	Washer-Bellville	6:2:4	103-0063	2	Seal-Caster
6	127-9540	1	Wheel And Axle ASM	6:2:5	1-633585	2	Bearing-Cone, Taper
6:1	103-2768	2	Guard-Seal	6:3	325-39	1	Screw-HH
6:2		1	Wheel And Bearing ASM ●	6:4	3296-23	1	Nut-Lock, NI
6:2:1		1	Wheel And Tire ASM ●	7	103-4882	1	Cap-Grease
6:2:1:1	1-523009	1	Tire	10	3296-51	1	Nut-Lock, NI
6:2:1:2	1-633584	2	Bearing-Cup				

● Not serviced separately

Hydro Drive System Assembly

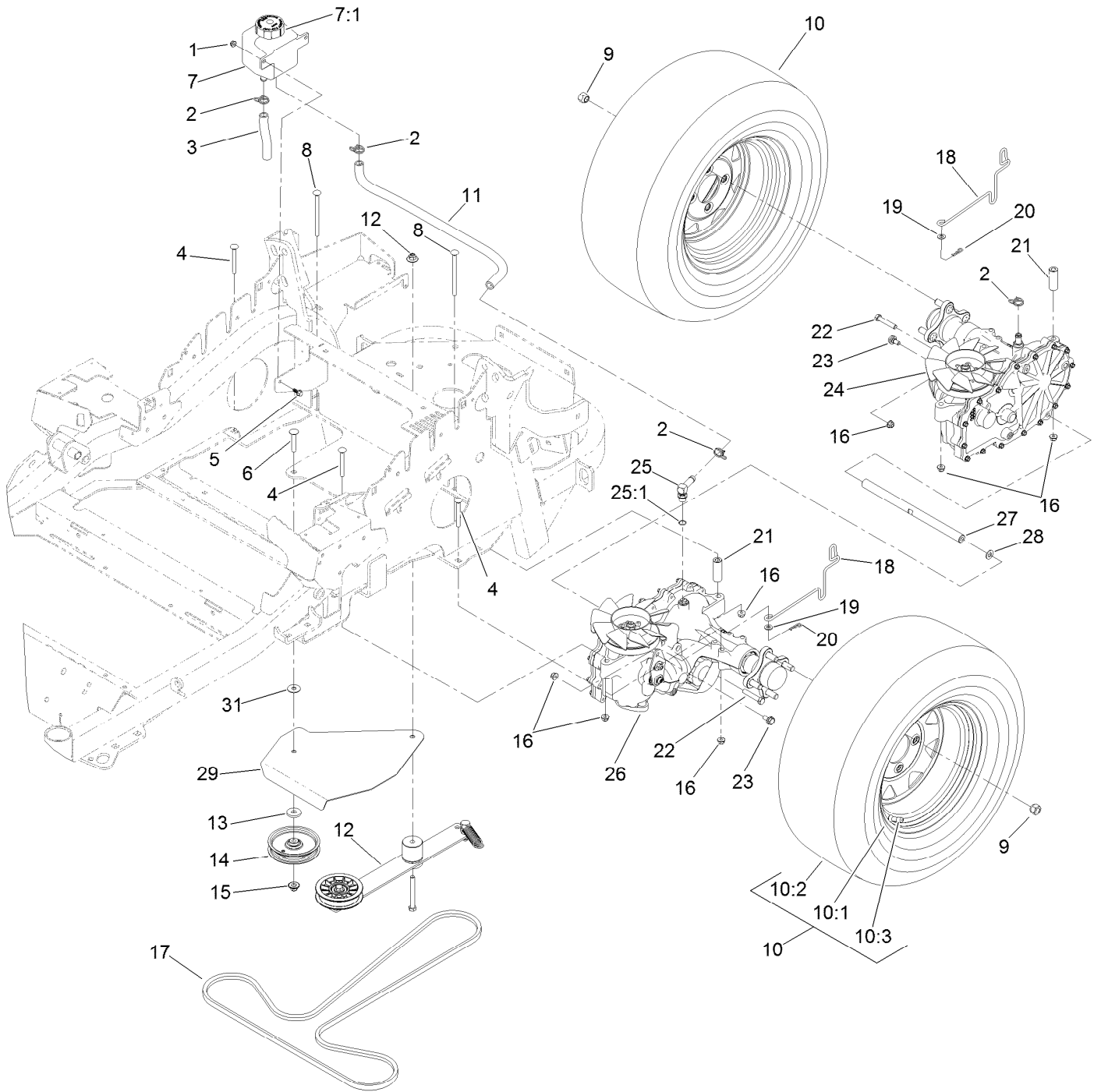

Hydro Drive System Assembly (continued)

<i>Ref.</i>	<i>Part Number</i>	<i>Qty.</i>	<i>Description</i>	<i>Ref.</i>	<i>Part Number</i>	<i>Qty.</i>	<i>Description</i>
1	104-7201	2	Nut-HF	15	109-6658	1	Nut-Flange, NI
2	117-1193	4	Clamp-Hose	16	104-8300	10	Nut-Flange, NI
3	119-2642	1	Hose-HYD	17	114860	1	Belt-V
4	3230-9	6	Screw-CARR	18	125-8950	2	Rod-Bypass
5	99-6810	2	Screw-HHF	19	3256-23	2	Washer-Flat
6	117-9971	1	Bolt-Carriage	20	1-806003	2	Pin-Cotter
7	109-2250	1	Vent-Tank, Hydro	21	109-3652	2	Spacer-Hydro
7:1	109-3320	1	Cap-Reservoir, HYD	22	94-7972	2	Screw-HH W/Loctite
8	3230-30	2	Screw-CARR	23	37-8771	2	Bolt-Shoulder
9	242-50	8	Nut-Lug	24	130-2850	1	RH Transaxle ASM
10	127-9508	2	Wheel And Tire ASM	25	109-6449	1	Fitting-Elbow, 90
10:1	127-9509	1	Wheel	25:1	237-42	1	O-Ring
10:2	120-3269	1	Tire	26	130-2851	1	LH Transaxle ASM
10:3	232-27	1	Stem-Valve	27	117-8585	1	Shaft-Cross, Hydro
11	119-2689	1	Hose-HYD	28	3256-24	1	Washer-Flat
12		1	Hydro Idler Arm ASM ●	29	125-4777-01	1	Plate-Guard
13	1-373034	1	Washer	31	52-2860	1	Washer
14	93-1622	1	Pulley-Idler				

● Not serviced separately

Hydro Idler Arm Assembly

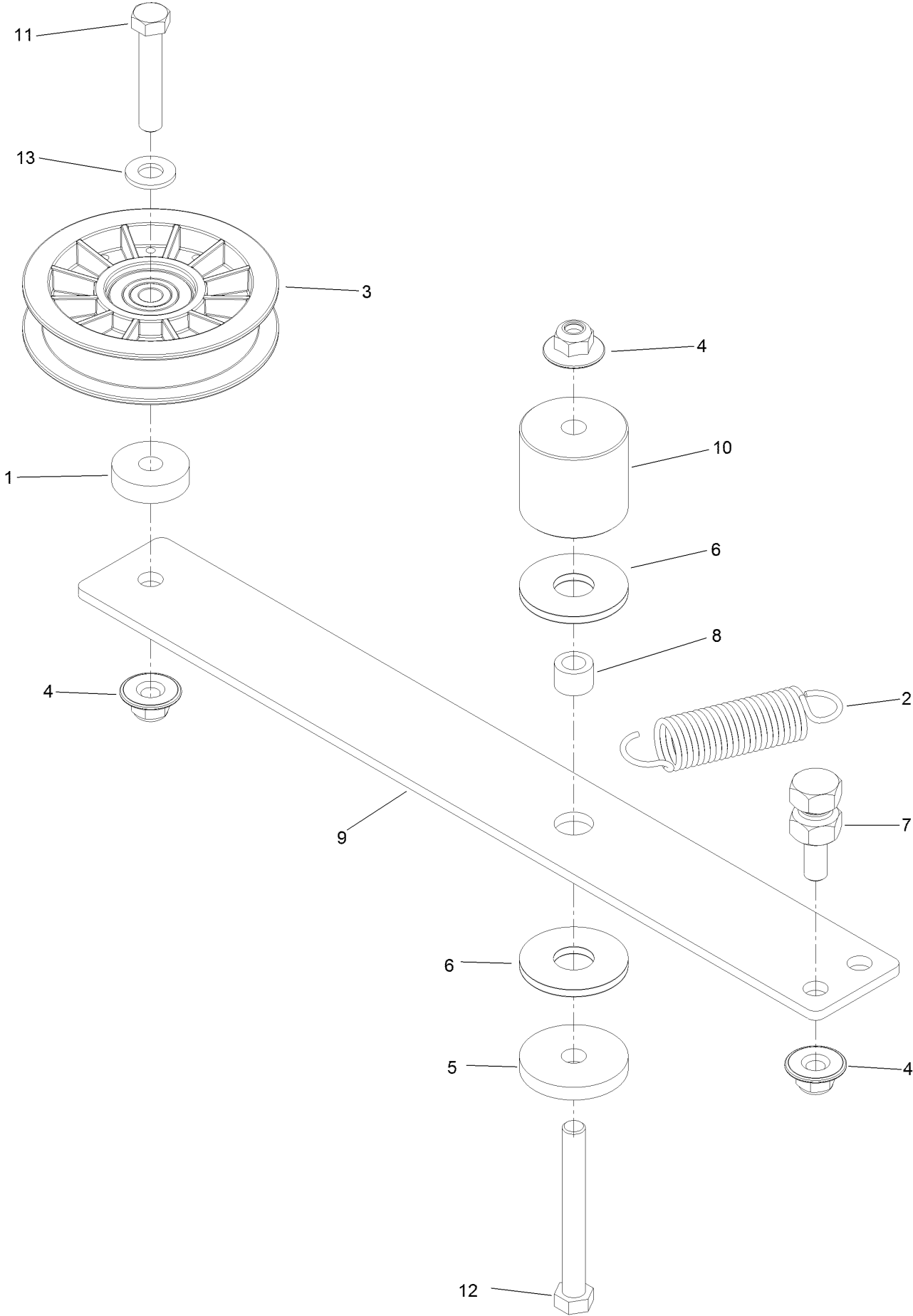

Hydro Idler Arm Assembly (continued)

<i>Ref.</i>	<i>Part Number</i>	<i>Qty.</i>	<i>Description</i>	<i>Ref.</i>	<i>Part Number</i>	<i>Qty.</i>	<i>Description</i>
1	105-7788	1	Spacer	8	115-4986	1	Spacer
2	108-4056	1	Spring-Extension	9	119-9914	1	Arm-Idler, Hydro
3	109-3397	1	Pulley-Idler, Flat	10	119-2657	1	Spacer-Plain
4	109-6658	3	Nut-Flange, NI	11	323-10	1	Screw-HH
5	110-9981	1	Washer-Plain	12	323-20	1	Screw-HH
6	114-0463	2	Washer-Friction, Composite	13	3256-24	1	Washer-Flat
7	114-5866	1	Anchor-Spring, Short				

RH Transaxle Assembly No. 130-2850 (continued)

<i>Ref.</i>	<i>Part Number</i>	<i>Qty.</i>	<i>Description</i>	<i>Ref.</i>	<i>Part Number</i>	<i>Qty.</i>	<i>Description</i>
1	121-3231	1	RH Main Housing Kit	80	94-1933	2	Washer
2	121-3232	1	RH Side Cover Kit	81	120-7973	1	Gear-46T
7	117-5359	16	Screw-HHF	82	120-7974	1	Gear-11T
10	130-8483	4	O-Ring	83	104-5329	1	Pin-Jackshaft
11	104-2189	1	Plug-Thread, Straight	90	104-2169	1	Ring-Retaining
13	104-2147	1	Sealant ●	91	121-3237	1	Gear-54T
23	109-3321	1	Element-Oil Filter, HYD	92	120-7975	1	Spacer
30	106-8676	1	Seal-Lip	93	130-8476	1	Bearing-Ball
31	106-8677	1	Ring-Retaining, EXT	94	121-3238	1	Shaft-Axle
32	114-1685	1	Rod-Bypass	95	130-8477	1	Bearing-Ball
33	106-8679	1	Ring-Retaining, Int	96	130-8478	1	Seal-Lip
34	107-2490	1	Arm-Bypass	97	109-5939	1	Hub Kit
35	106-8681	1	Ring-Retaining, EXT	100	114-1697	1	Pawl-Brake
40	104-5304	1	Swashplate-Trunnion	101	130-8479	1	Shaft-Brake
41	104-5313	1	Seal-Lip	102	125-0021	1	Handle-Brake
42	104-2116	1	Stud	103	130-8484	1	Ring-Retaining, EXT
43	112-9853	1	Puck-Friction	105	104-2120	3	Screw
50	120-5537	1	Spring-Compression	106	120-7981	1	Guard-Filter, RH
51	120-5538	1	Washer	111	109-3278	1	Adapter-Straight
55	104-5308	1	Spacer	130	130-8485	2	Tube-Push, O-Ring
56	104-5310	1	Seal-Lip	156	115-5057	1	Cover-Nut, Axle
57	104-5309	1	Ring-Retaining	157	130-8486	1	Seal-Gerotor
60	109-2865	1	Bearing-Thrust	158	104-5330	1	Magnet-Ring
64	114-1689	1	Motor Cylinder Block Kit	164	130-8480	1	Spacer
65	121-3235	1	Bearing-Thrust, Plastic Cage	200	121-3243	1	Seal Kit
69	121-3236	1	7 Piston Block ASM	201	130-8481	1	Center Section Kit
70	104-5339	1	Washer-Flat	202	114-8464	1	Charge Relief Kit
71	104-5340	1	Ring-Retaining	203	121-3246	1	Charge Pump Kit
72	120-7972	1	Gear-13T	207	121-3247	1	Fan And Pulley Kit
73	114-1691	1	Shaft-Motor	209	130-8482	1	Hub Puller Kit
74	104-5360	1	Washer	210	121-3248	1	Input Shaft Kit
				211	117-5362	1	Arm Control Kit

● Not illustrated

LH Transaxle Assembly No. 130-2851

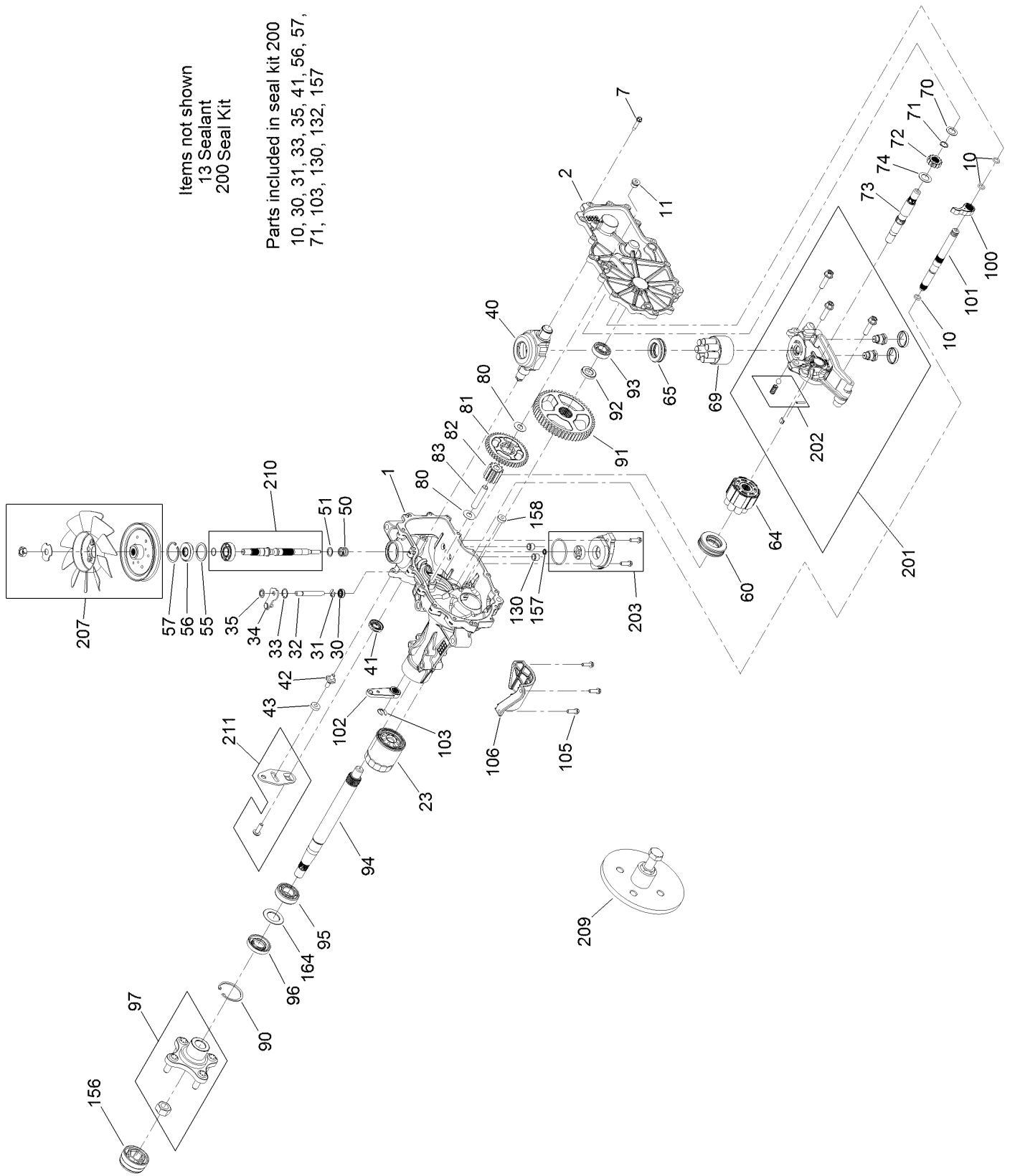

Items not shown
 13 Sealant
 200 Seal Kit

Parts included in seal kit 200
 10, 30, 31, 33, 35, 41, 56, 57,
 71, 103, 130, 132, 157

LH Transaxle Assembly No. 130-2851 (continued)

<i>Ref.</i>	<i>Part Number</i>	<i>Qty.</i>	<i>Description</i>	<i>Ref.</i>	<i>Part Number</i>	<i>Qty.</i>	<i>Description</i>
1	121-3233	1	LH Main Housing Kit	80	94-1933	2	Washer
2	121-3234	1	LH Side Cover Kit	81	120-7973	1	Gear-46T
7	117-5359	16	Screw-HHF	82	120-7974	1	Gear-11T
10	130-8483	4	O-Ring	83	104-5329	1	Pin-Jackshaft
11	104-2189	1	Plug-Thread, Straight	90	104-2169	1	Ring-Retaining
13	104-2147	1	Sealant ●	91	121-3237	1	Gear-54T
23	109-3321	1	Element-Oil Filter, HYD	92	120-7975	1	Spacer
30	106-8676	1	Seal-Lip	93	130-8476	1	Bearing-Ball
31	106-8677	1	Ring-Retaining, EXT	94	121-3238	1	Shaft-Axle
32	114-1685	1	Rod-Bypass	95	130-8477	1	Bearing-Ball
33	106-8679	1	Ring-Retaining, Int	96	130-8478	1	Seal-Lip
34	107-2490	1	Arm-Bypass	97	109-5939	1	Hub Kit
35	106-8681	1	Ring-Retaining, EXT	100	114-1697	1	Pawl-Brake
40	104-5304	1	Swashplate-Trunnion	101	114-1698	1	Shaft-Brake, Inboard
41	104-5313	1	Seal-Lip	102	125-0021	1	Handle-Brake
42	104-2116	1	Stud	103	130-8484	1	Ring-Retaining, EXT
43	112-9853	1	Stud-Friction	105	104-2120	3	Screw
50	120-5537	1	Spring-Compression	106	120-7979	1	Guard-Filter, LH
51	120-5538	1	Washer	130	130-8485	2	Tube-Push, O-Ring
55	104-5308	1	Spacer	156	115-5057	1	Cover-Nut, Axle
56	104-5310	1	Seal-Lip	157	130-8486	1	Seal-Gerotor
57	104-5309	1	Ring-Retaining	158	104-5330	1	Magnet-Ring
60	109-2865	1	Bearing-Thrust	164	130-8480	1	Spacer
64	114-1689	1	Motor Cylinder Block Kit	200	121-3243	1	Seal Kit
65	121-3235	1	Bearing-Thrust, Plastic Cage	201	130-8487	1	Kit-Center Section (LH Charge)
69	121-3236	1	7 Piston Block ASM	202	114-8464	1	Charge Relief Kit
70	104-5339	1	Washer-Flat	203	121-3246	1	Charge Pump Kit
71	104-5340	1	Ring-Retaining	207	121-3247	1	Fan And Pulley Kit
72	120-7972	1	Gear-13T	209	130-8482	1	Hub Puller Kit
73	114-1691	1	Shaft-Motor	210	121-3248	1	Input Shaft Kit
74	104-5360	1	Washer	211	117-5362	1	Arm Control Kit

● Not illustrated

Fuel Tank and Hose Assembly

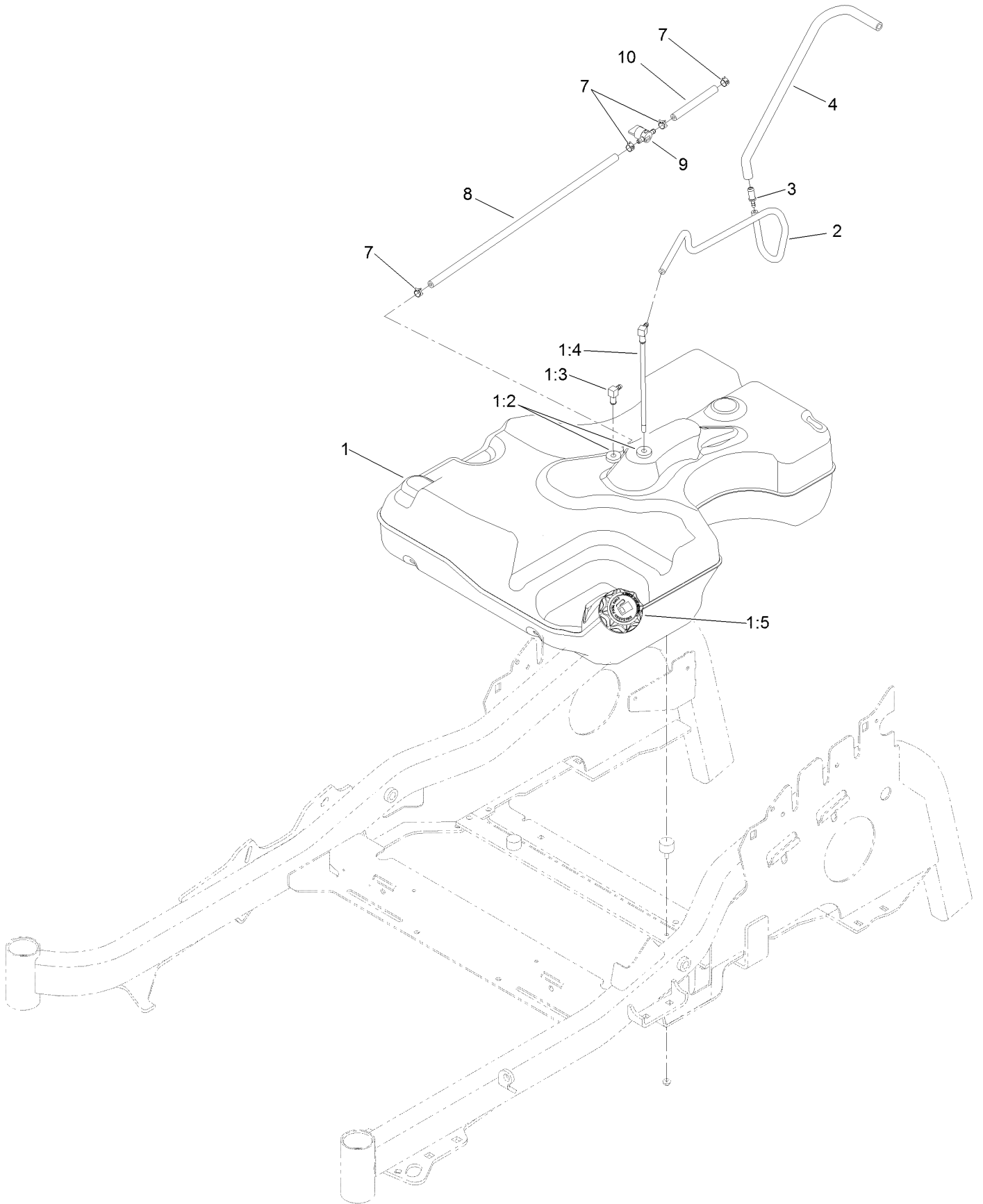

Fuel Tank and Hose Assembly (continued)

<i>Ref.</i>	<i>Part Number</i>	<i>Qty.</i>	<i>Description</i>	<i>Ref.</i>	<i>Part Number</i>	<i>Qty.</i>	<i>Description</i>
1	125-4765	1	Fuel Tank ASM	3	98-2952	1	Fitting-Straight
1:2	46-6560	2	Bushing	4	119-8562	1	Hose-Fuel
1:3	116-2288	1	Fitting-90 Elbow	7	2412-98	4	Clamp-Hose
1:4	125-4767	1	Fuel Line ASM	8	110-5701	1	Hose-Fuel
1:5	126-1789	1	Cap-Fuel, Ratcheting	9	1-603770	1	Valve-Fuel
2	119-6074	1	Hose-Fuel	10	109-0650	1	Hose-Fuel

Seat Mounting Assembly

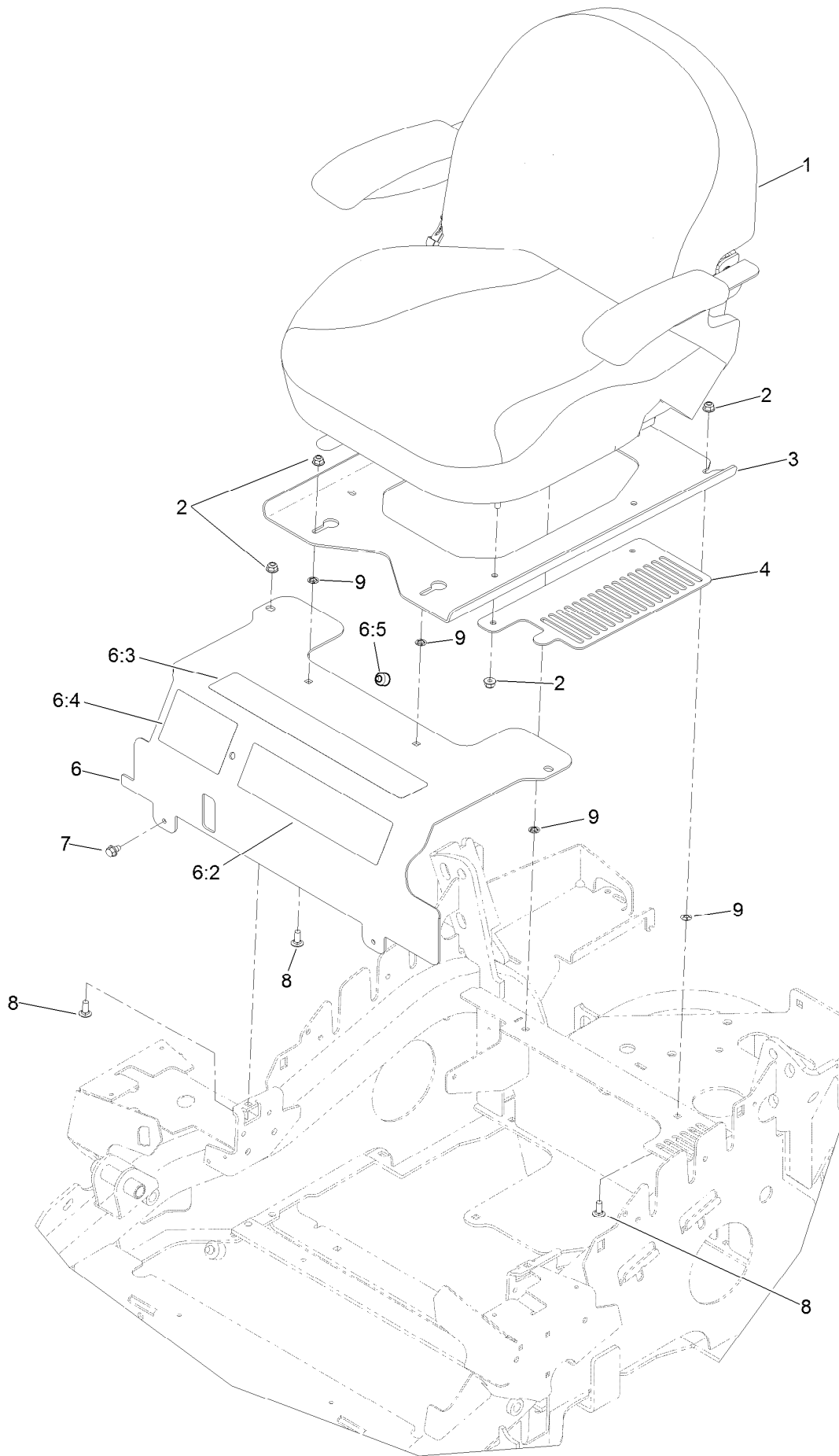

Seat Mounting Assembly (continued)

<i>Ref.</i>	<i>Part Number</i>	<i>Qty.</i>	<i>Description</i>	<i>Ref.</i>	<i>Part Number</i>	<i>Qty.</i>	<i>Description</i>
1	127-9538	1	Seat ASM	6:3	116-8722	1	Decal-Console
2	104-8300	10	Nut-Flange, NI	6:4	127-0325	1	Decal-Service Aid
3	117-8615-03	1	Plate-Mount, Seat	6:5	120-7893	1	Bumper-Grommet
4	117-8618-03	2	Plate-Cover, Fan	7	9266934	2	Screw
6	119-2597	1	Seat Mount Panel ASM	8	3230-23	6	Screw-CARR
6:2	114-5878	1	Decal	9	117-2749	4	Nut-Push

Seat Assembly No. 127-9538

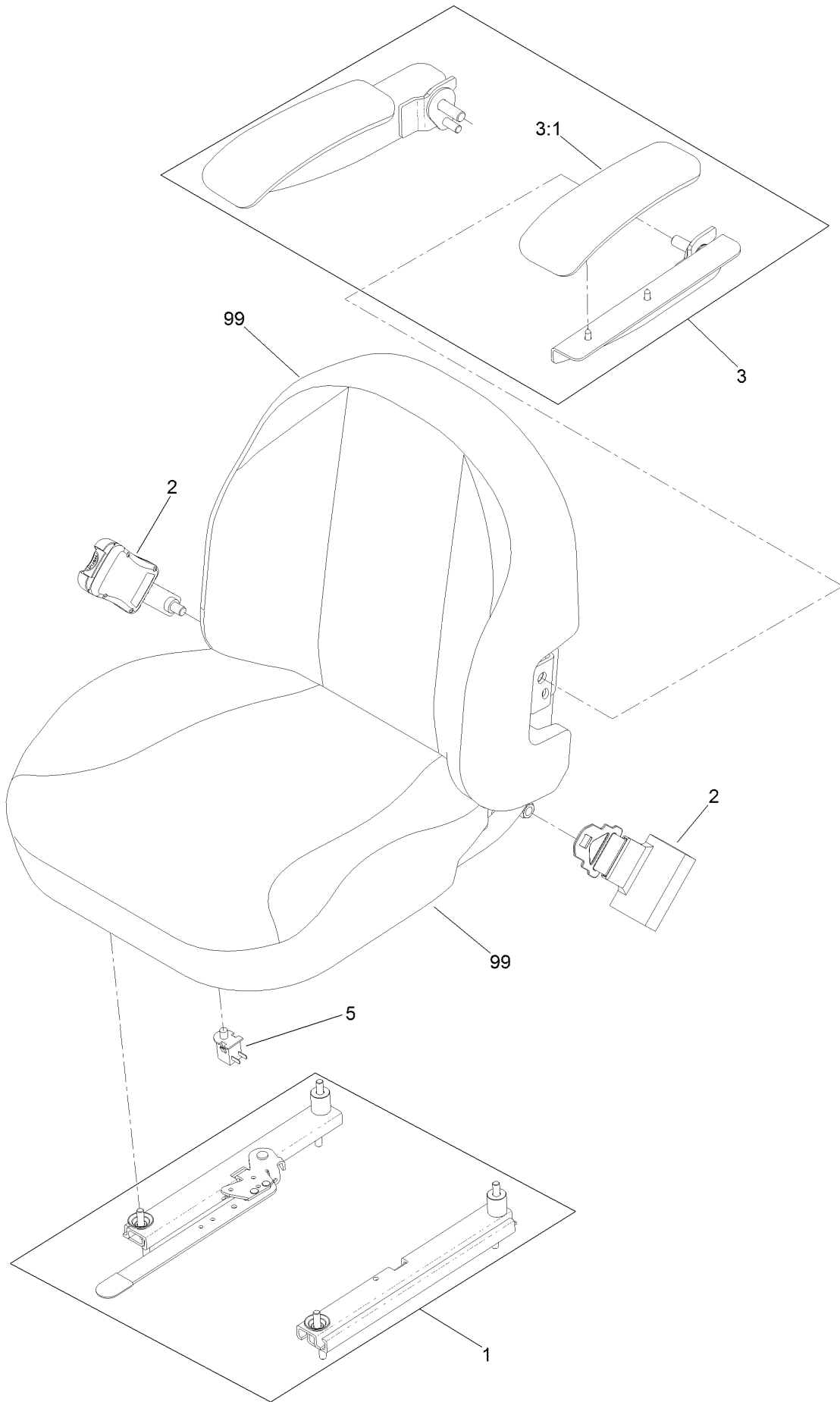

Seat Assembly No. 127-9538 (continued)

<i>Ref.</i>	<i>Part Number</i>	<i>Qty.</i>	<i>Description</i>	<i>Ref.</i>	<i>Part Number</i>	<i>Qty.</i>	<i>Description</i>
1	130-2853	1	Seat Track Kit	5	82-2190	1	Switch-Bail
2	130-2854	1	Seat Belt Kit	99	130-2856	1	Cover-Seat, Bottom
3	126-2058	1	Armrest Kit	99	130-2855	1	Cover-Seat, Back
3:1	110-4163	2	Cushion-Rest, Arm				

Motion Control Assembly

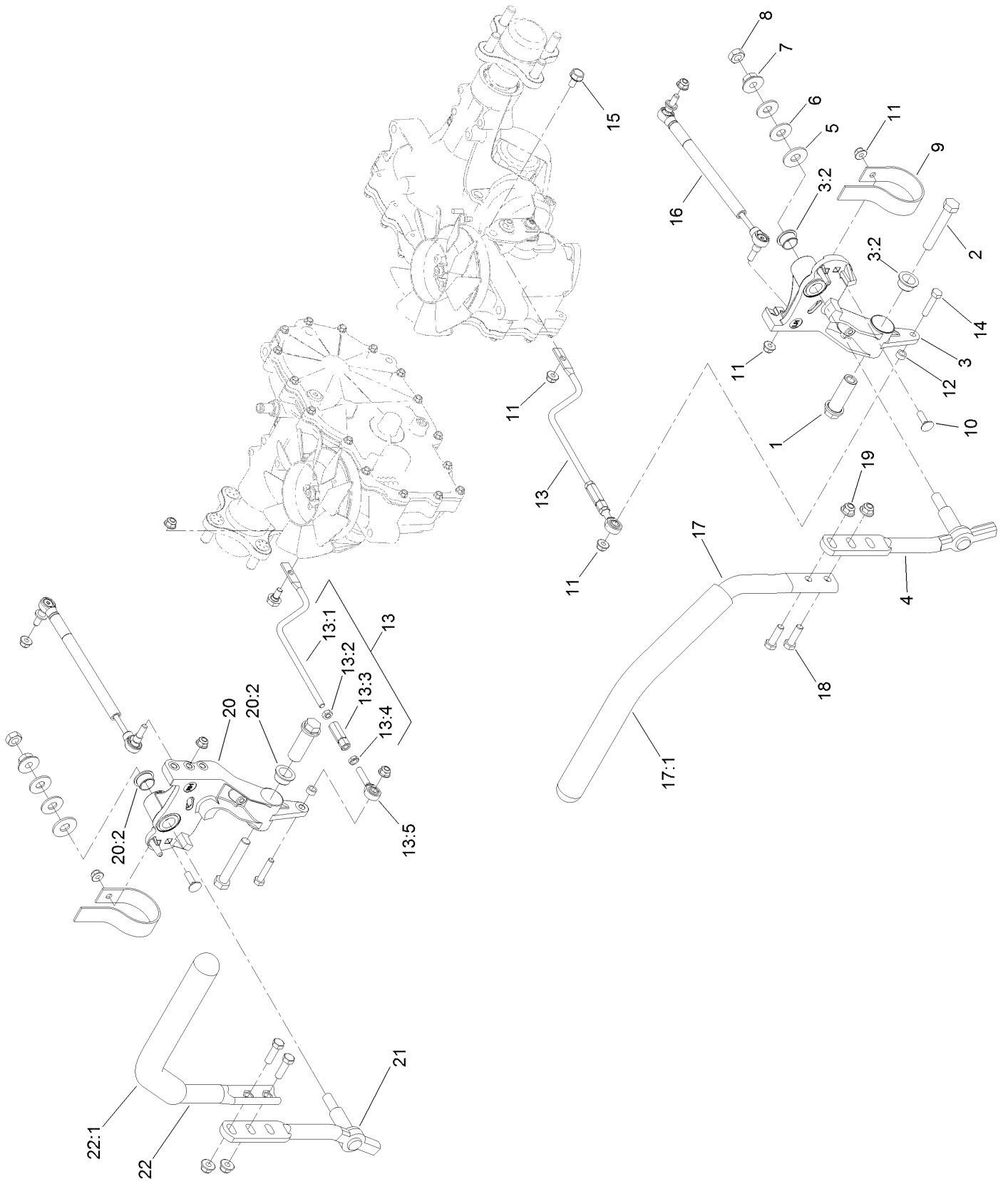

Motion Control Assembly (continued)

<i>Ref.</i>	<i>Part Number</i>	<i>Qty.</i>	<i>Description</i>	<i>Ref.</i>	<i>Part Number</i>	<i>Qty.</i>	<i>Description</i>
1	109-5891	2	Hub-Threaded	13:3	109-3728	1	Nut-Rod Adjustment
2	325-12	2	Screw-HH	13:4	3220-20	1	Nut-Jam
3	116-0881	1	LH Motion Control And Bushing ASM	13:5	2411-53	1	Bearing-Rod End, LH
3:2	109-8054	4	Bushing-Flange	14	322-7	2	Screw-HH
4	116-0040	1	Lever-Control Motion, LH	15	37-8771	2	Bolt-Shoulder
5	3256-6	2	Washer-Flat	16	116-0027	2	Damper-Control, Motion
6	109-9505	4	Washer-Spring	17	109-6590	1	LH Steering Handle ASM
7	32128-56	2	Nut-HF	17:1	109-5668	1	Grip-Control, Lever
8	3218-5	2	Nut-Jam	18	323-7	4	Screw-HH
9	109-5575	2	Spring-Leaf	19	104-8301	4	Nut-Flange, NI
10	3230-2	2	Bolt-CARR	20	116-0880	1	RH Motion Control And Bushing ASM
11	104-8300	10	Nut-Flange, NI	20:2	109-8054	4	Bushing-Flange
12	92-6998	2	Spacer-Yoke, Right	21	116-0039	1	Lever-Control Motion, RH
13	119-2605	2	Hydro Control Rod ASM	22	109-6589	1	RH Steering Handle ASM
13:1	119-2606	1	Rod-Control, Hydro	22:1	109-5668	1	Grip-Control, Lever
13:2	3220-2	1	Nut-Jam				

Parking Brake Assembly

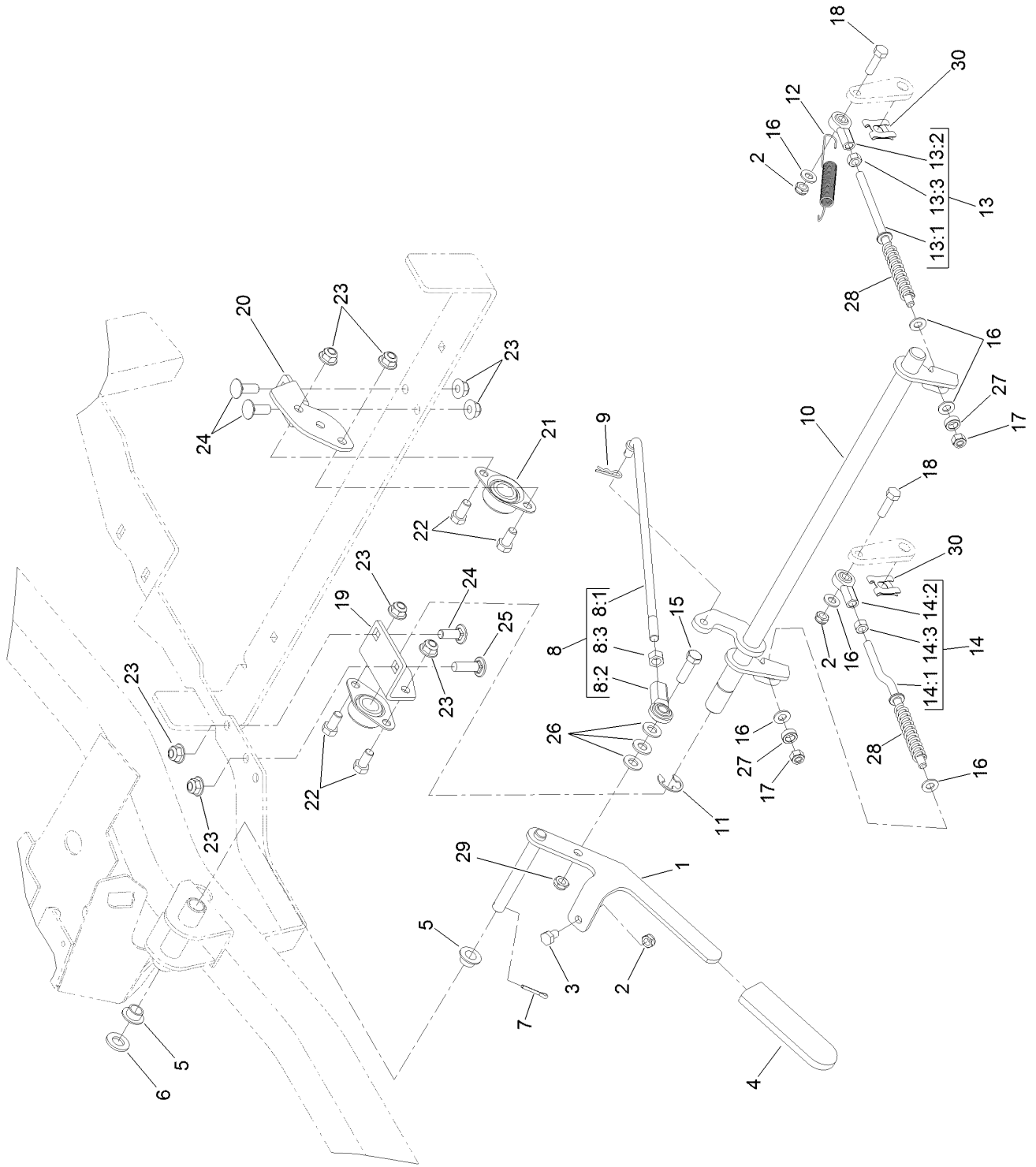

Parking Brake Assembly (continued)

<i>Ref.</i>	<i>Part Number</i>	<i>Qty.</i>	<i>Description</i>	<i>Ref.</i>	<i>Part Number</i>	<i>Qty.</i>	<i>Description</i>
1	121-4766-03	1	Handle-Brake	14:1	121-4770	1	Rod-Brake
2	3296-47	3	Nut-Lock, NI	14:2	1-543017	1	Balljoint-RH
3	322-1	1	Screw-HH	14:3	3219-2	1	Nut-Hex
4	1-633268	1	Grip-Lever	15	323-7	1	Screw-HH
5	1-513140	2	Bearing-Control	16	3256-23	6	Washer-Flat
6	106-9888	1	Washer-Flat	17	3296-4	2	Nut-Lock
7	3272-10	1	Pin-Cotter	18	322-16	2	Screw-HH
8	121-4807	1	Brake Link ASM	19	121-4761-01	1	Bracket-Shaft Mount, RH
8:1	121-4795	1	Rod-Link, Brake	20	121-4793-01	1	Bracket-Shaft Mount, LH
8:2	103-0608	1	Joint-Ball, End	21	1-633102	2	Bearing-Flange, Side
8:3	3219-3	1	Nut-Hex	22	323-4	4	Screw-HH
9	3290-307	1	Pin-Cotter	23	104-8301	8	Nut-Flange, NI
10	121-4804-03	1	Shaft-Brake	24	3231-22	3	Screw-CARR
11	32151-48	1	E-Ring	25	3231-28	1	Screw-CARR
12	110769	1	Spring-Extension	26	3256-24	3	Washer-Flat
13	121-4805	1	LH Brake Rod ASM	27	103-5677	2	Spacer
13:1	121-4755	1	Rod-Brake	28	1-603807	2	Spring-Return, Neutral
13:2	1-543017	1	Balljoint-RH	29	3296-59	1	Nut-Lock, NI
13:3	3219-2	1	Nut-Hex	30	114-8450	2	Clip-Retaining
14	121-4806	1	RH Brake Rod ASM				

Engine, Muffler and Control Panel Assembly

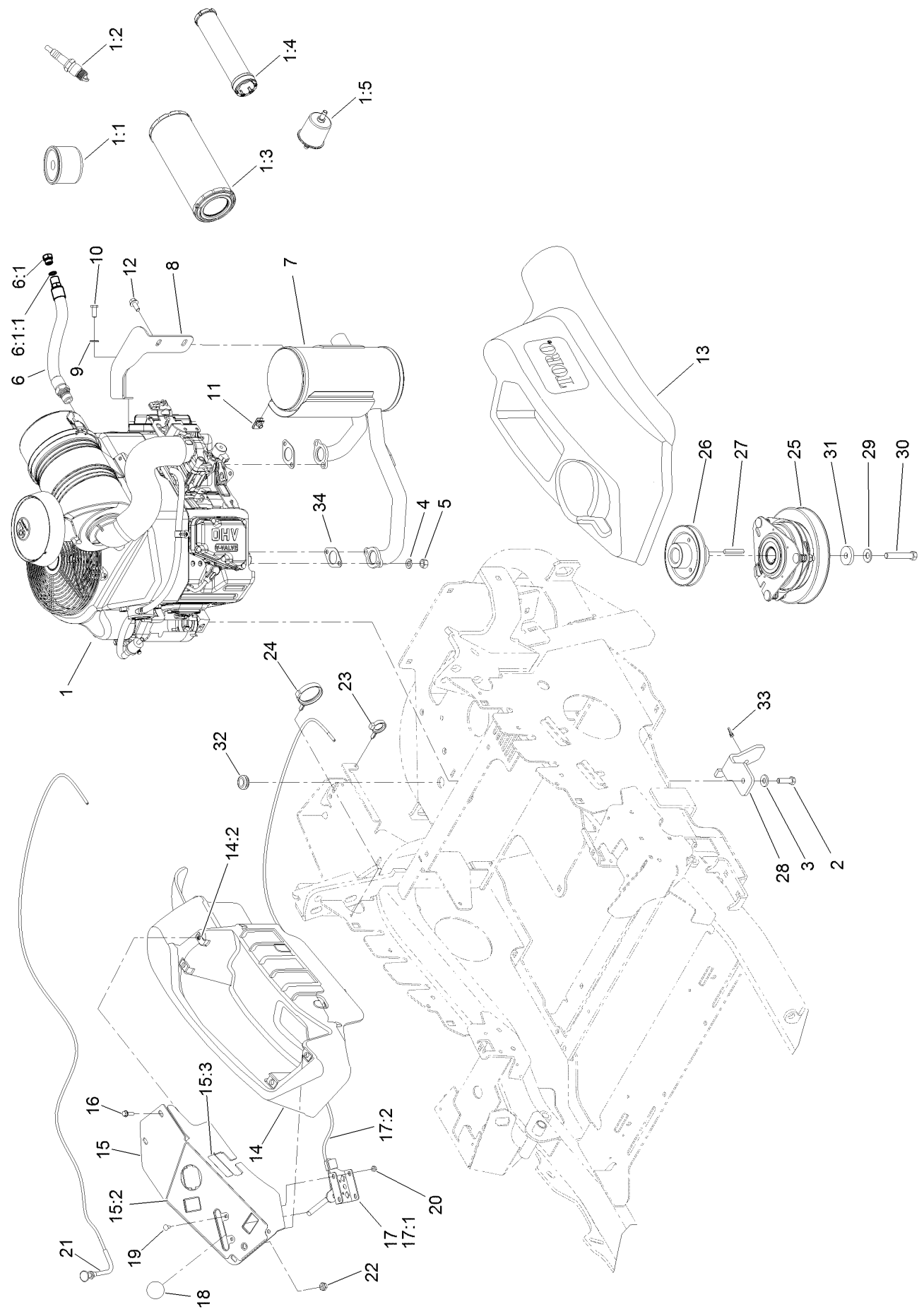

Engine, Muffler and Control Panel Assembly (continued)

<i>Ref.</i>	<i>Part Number</i>	<i>Qty.</i>	<i>Description</i>	<i>Ref.</i>	<i>Part Number</i>	<i>Qty.</i>	<i>Description</i>
1		1	Engine-Kawasaki, Fx730 ●■	15:2	119-2501	1	Decal-Panel, Control
1:1	119-5852	1	Filter-Oil	15:3	114-4466	1	Decal-Fuses
1:2	92-2153	1	Spark Plug	16	32105-15	4	Screw-HWH
1:3	119-5944	1	Element-Filter, Air (Outer)	17	110-5727	1	Throttle Control ASM
1:4	119-5945	1	Element-Filter, Air (Inner)	17:1	112-2334	1	Lever-Throttle
1:5	125-6445	1	Filter-Fuel	17:2	110-5728	1	Cable-Throttle
2	323-7	4	Screw-HH	18	1-603175	1	Knob-Ball
3	98-5975	4	Washer-Belleville	19	1-807513	2	Bolt-CARR
4	114-3550	4	Washer-Lock, Spring	20	3296-2	2	Nut-Lock, NI
5	114-3549	4	Nut	21	115-2753	1	Control-Choke
6	116-4924	1	Engine Oil Drain Hose ASM	22	3220-3	1	Nut-HJ
6:1	353-508	1	Plug-HH	23	105-1853	1	Clamp-Hose
6:1:1	237-42	1	O-Ring	24	117-7817	1	Clamp-Harness
7	119-2645	1	Muffler	25	119-2595	1	Clutch
8	119-2659	1	Bracket-Muffler	26	119-9915	1	Pulley-Engine
9	1-303334	1	Washer-Spring	27	608006	1	Key-Square
10	33114-020	1	Screw-HH	28	119-2658-01	1	Bracket-Stop, Clutch
11	94-2413	2	U-Nut	29	1-603610	1	Washer-Spring
12	3234-5	2	Screw-HHF	30	3212-10	1	Screw-HH
13	119-2602	1	LH Console ASM	31	107-4136	1	Washer
14	119-2603	1	RH Console ASM	32	112-7069	1	Grommet
14:2	107069	4	Clip	33	1-303287	1	Tie-Cable
15	119-2694	1	Control Panel ASM	34	1-653313	2	Gasket-Exhaust

● Not serviced separately

■ Obtain parts from www.kawpowerepc.com

Deck Lift Assembly

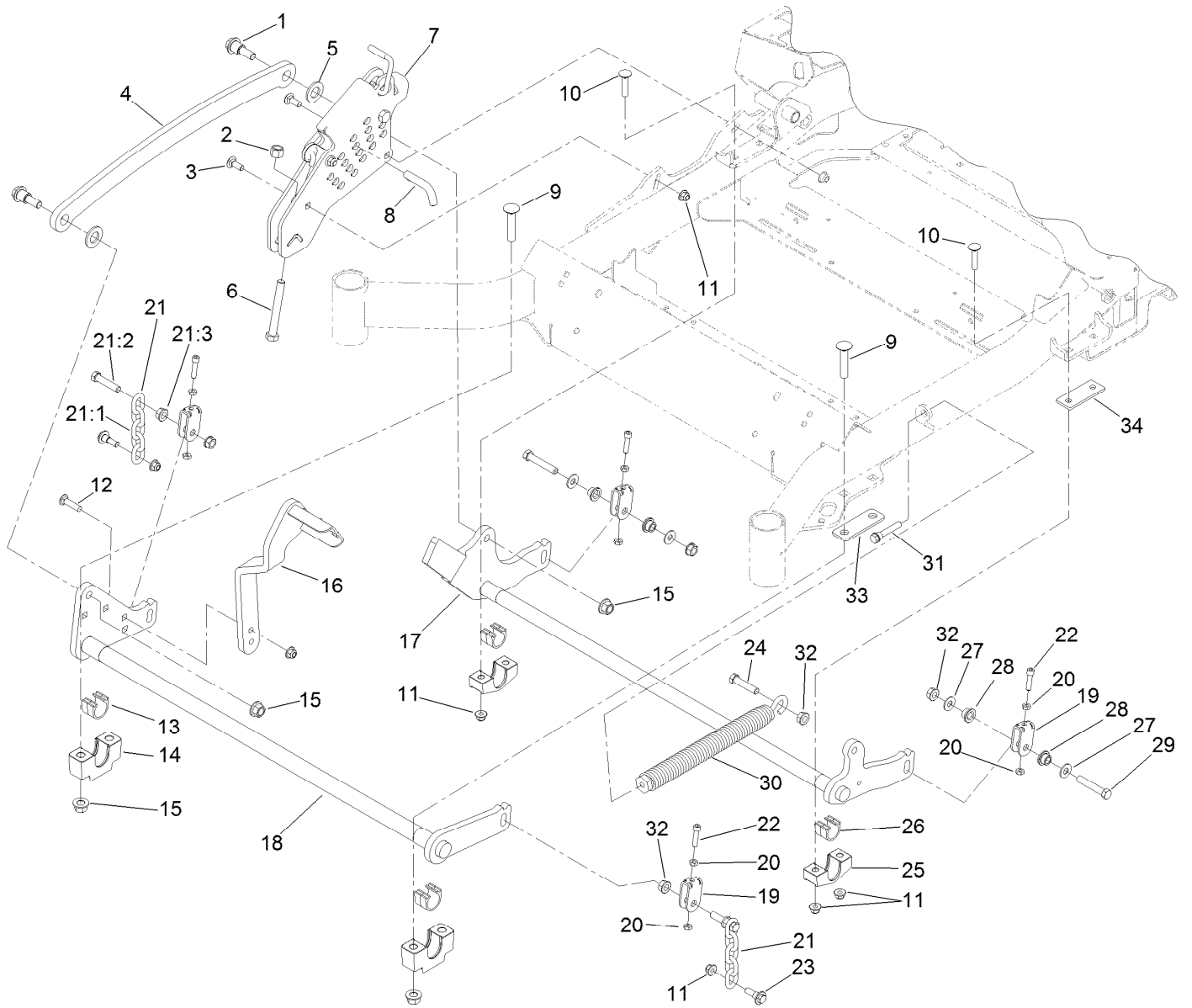

Deck Lift Assembly (continued)

<i>Ref.</i>	<i>Part Number</i>	<i>Qty.</i>	<i>Description</i>	<i>Ref.</i>	<i>Part Number</i>	<i>Qty.</i>	<i>Description</i>
1	116-0780	2	Screw-HHF, Shoulder	20	3218-2	8	Nut-Jam
2	3296-23	1	Nut-Lock, NI	21	116-0756	2	Deck Lift Chain ASM
3	3231-2	2	Bolt-CARR	21:1	1-633447	1	Chain-Lift, Deck
4	116-0797-03	1	Link-Lift, Deck	21:2	109-9065	1	Screw-HH
5	3256-28	2	Washer-Flat	21:3	32128-37	1	Nut-HF
6	116-0559	1	Bolt-TAP	22	322-47	4	Screw-HH
7	120-2530	1	HOC ASM	23	109-9840	2	Screw-Shoulder, HHF
8	116-5584	1	Pin-HOC	24	109-9065	1	Screw-HH
9	116-1700	4	Bolt-CARR	25	116-0818-03	2	Support-Cross Shaft, Rear Bearing
10	3231-5	4	Screw-CARR	26	109-7173	2	Bearing-Cross Shaft, Rear
11	104-8301	10	Nut-Flange, NI	27	3256-4	4	Washer-Flat
12	3231-4	2	Screw-CARR	28	116-2428	4	Bushing-Flanged
13	109-9410	2	Bearing-Cross Shaft, Front	29	324-10	2	Screw-HH
14	109-9409	2	Support-Cross Shaft, Front Bearing	30	116-0886	1	Extension Spring ASM
15	99-5107	6	Nut-Lock	31	92-7674	1	Bolt-Shoulder
16	116-1919-01	1	Lever-Foot	32	32128-37	6	Nut-HF
17	116-0459-03	1	Lift-Deck, Rear	33	121-7593-01	2	Spacer-Decklift, Front
18	126-2475-03	1	Decklift-Front	34	121-7594-01	2	Spacer-Decklift, Back
19	109-9066	4	Yoke-Adjust, Deck				

Height-of-Cut Assembly No. 120-2530

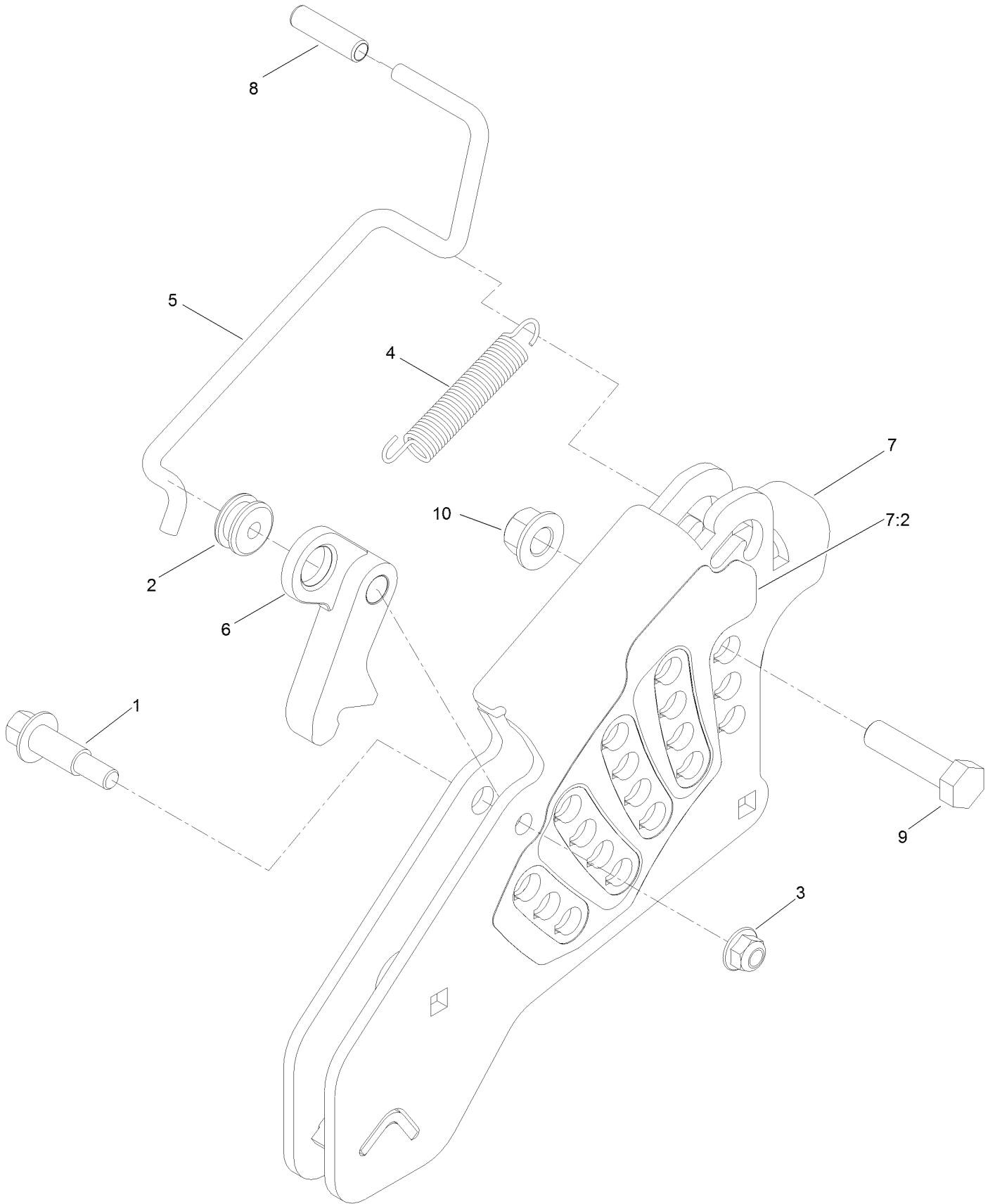

Height-of-Cut Assembly No. 120-2530 (continued)

<i>Ref.</i>	<i>Part Number</i>	<i>Qty.</i>	<i>Description</i>	<i>Ref.</i>	<i>Part Number</i>	<i>Qty.</i>	<i>Description</i>
1	62-1330	1	Bolt-Shoulder	7	120-2531	1	HOC Plate ASM
2	109-7130	1	Grommet	7:2	120-2532	1	Decal-HOC
3	104-8301	1	Nut-Flange, NI	8	109-8250	1	Grip-Lever
4	109-7124	1	Spring-Extension	9	325-8	1	Screw-HH
5	109-7128	1	Rod-Lock, Transport	10	99-5107	1	Nut-Lock
6	116-0118	1	Pawl-Transport, HOC				

Deck Assembly

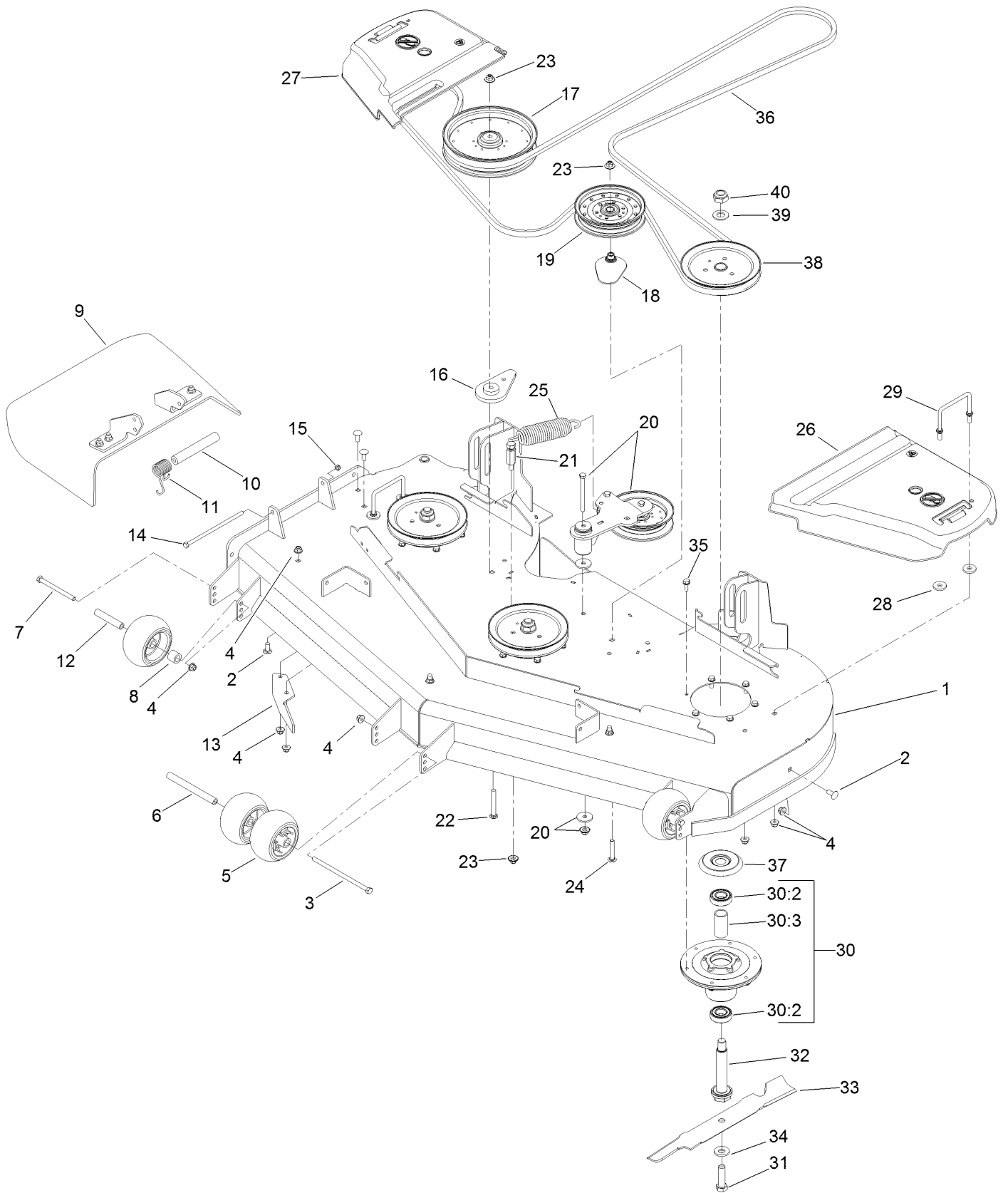

Deck Assembly (continued)

<i>Ref.</i>	<i>Part Number</i>	<i>Qty.</i>	<i>Description</i>	<i>Ref.</i>	<i>Part Number</i>	<i>Qty.</i>	<i>Description</i>
1	120-2461	1	Deck Decal ASM	22	3231-42	1	Screw-CARR
2	3231-27	6	Screw-CARR	23	109-6658	3	Nut-Flange, NI
3	108-5388	1	Screw-HH	24	3231-40	1	Bolt-CARR, Short Neck
4	104-8301	13	Nut-Flange, NI	25	116-6317	1	Spring-Extension
5	1-603299	4	Roller-Scalp, Anti	26	109-6938	1	Cover-Belt, LH
6	98-5967	1	Spacer-Wheel	27	116-0094	1	Cover-Belt, RH
7	323-23	2	Screw-HH	28	1-373034	4	Washer
8	98-7913	2	Tube-Spacer	29	109-6982	2	Wireform-Cover
9	120-2451	1	Deflector ASM	30	120-5477	3	Spindle ASM
10	105-4622	1	Spacer	30:2	116-0720	2	Bearing-Ball
11	108-4052	1	Spring-Torsion	30:3	115-2641	1	Spacer-Bearing
12	98-7912	2	Tube-Spanner	31	51-4060	3	Screw-Blade
13	106-3216-01	1	Baffle-Discharge	32	120-2505	3	Spindle-Shaft
14	322-50	1	Screw-HH	33	115-9649-03	3	Blade-Hi Flo, 20.5In
15	3296-47	1	Nut-Lock, NI	34	125-1736	3	Washer-Belleville
16	109-9416	1	Spacer-Idler	35	32144-41	18	Screw-Taptite
17	109-8590	1	Pulley-Idler	36	114-5858	1	Belt-V
18	109-2872	1	Spacer-Pulley	37	117-7210	3	Shield-Bearing
19	116-4670	1	Pulley-Idler, Flat	38	120-7856	3	Pulley B Section
20		1	Idler Arm ASM ●	39	92-5836	3	Washer
21	114-5867	1	Anchor-Spring, Tall	40	3296-67	3	Nut-Lock, NI

● Not serviced separately

Deck Decal Assembly No. 120-2461

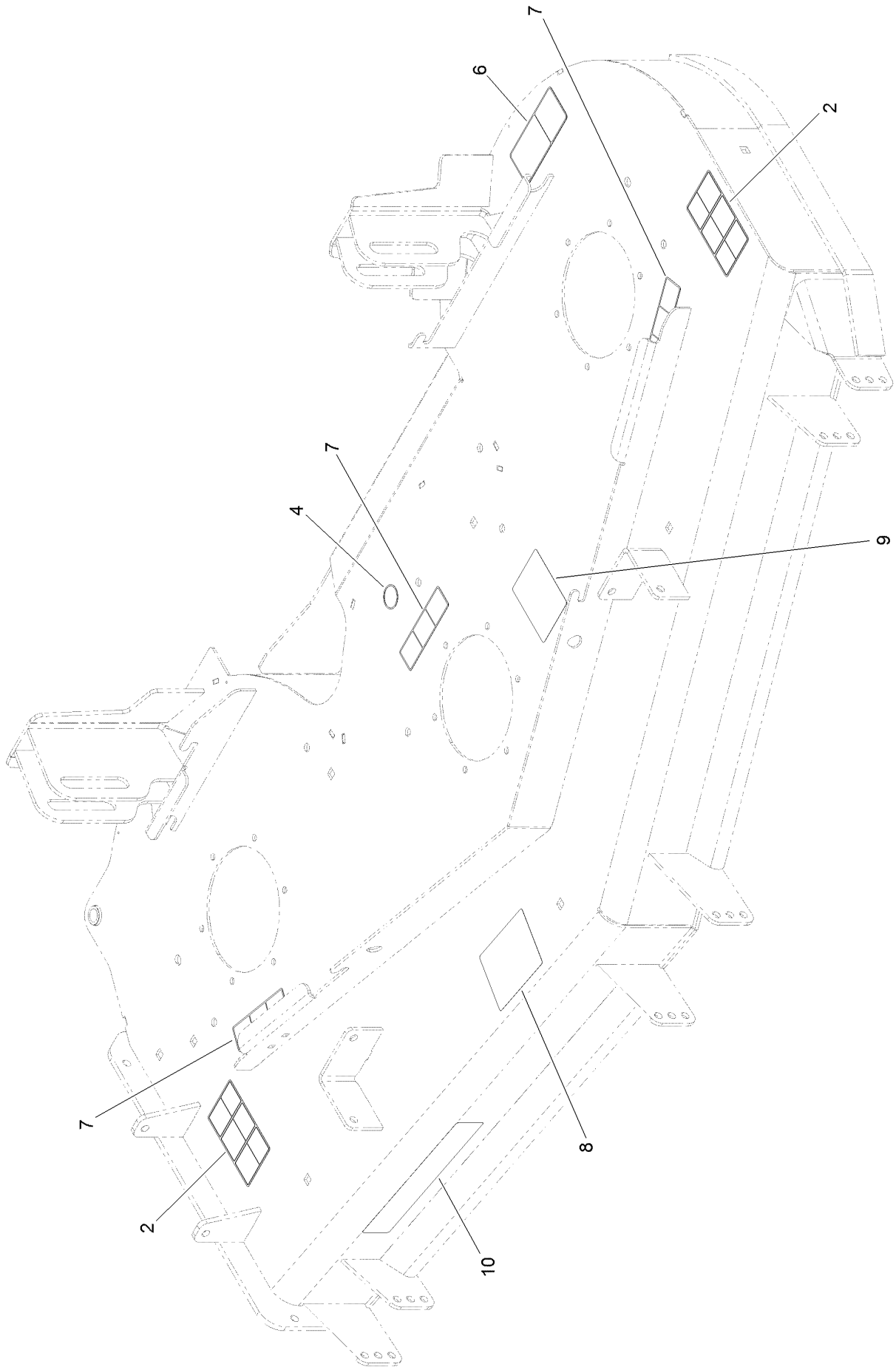

Deck Decal Assembly No. 120-2461 (continued)

<i>Ref.</i>	<i>Part Number</i>	<i>Qty.</i>	<i>Description</i>	<i>Ref.</i>	<i>Part Number</i>	<i>Qty.</i>	<i>Description</i>
2	117-3848	2	Decal-Danger	8	112-3858	1	Decal-Anti Scalp
4	58-6520	1	Decal-Grease	9	117-8639	1	Decal-Routing, Deck Belt
6	93-7818	1	Decal-Torque, Blade Bolt	10	121-3206	1	Decal
7	112-9028	3	Decal-Cover Missing				

Deflector Assembly No. 120-2451

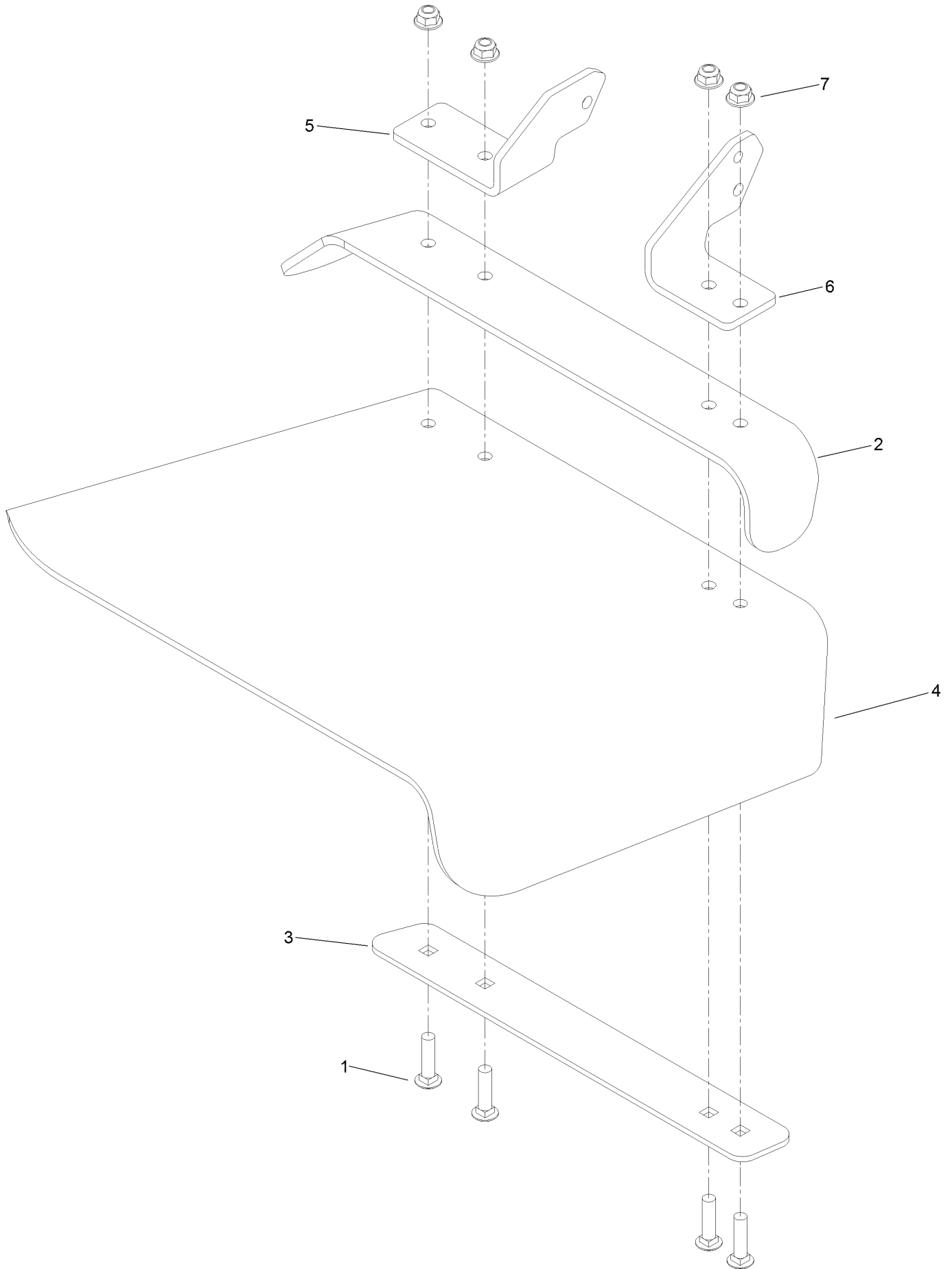

Deflector Assembly No. 120-2451 (continued)

<i>Ref.</i>	<i>Part Number</i>	<i>Qty.</i>	<i>Description</i>	<i>Ref.</i>	<i>Part Number</i>	<i>Qty.</i>	<i>Description</i>
1	3231-4	4	Screw-CARR	5	108-4059-01	1	Plate-Hinge, Rear
2	106-3246-01	1	Deflector	6	106-3253-01	1	Plate-Hinge, Front
3	106-3248-03	1	Strap-Discharge	7	104-8301	4	Nut-Flange, NI
4	110-0759	1	Deflector-Rubber				

Idler Assembly

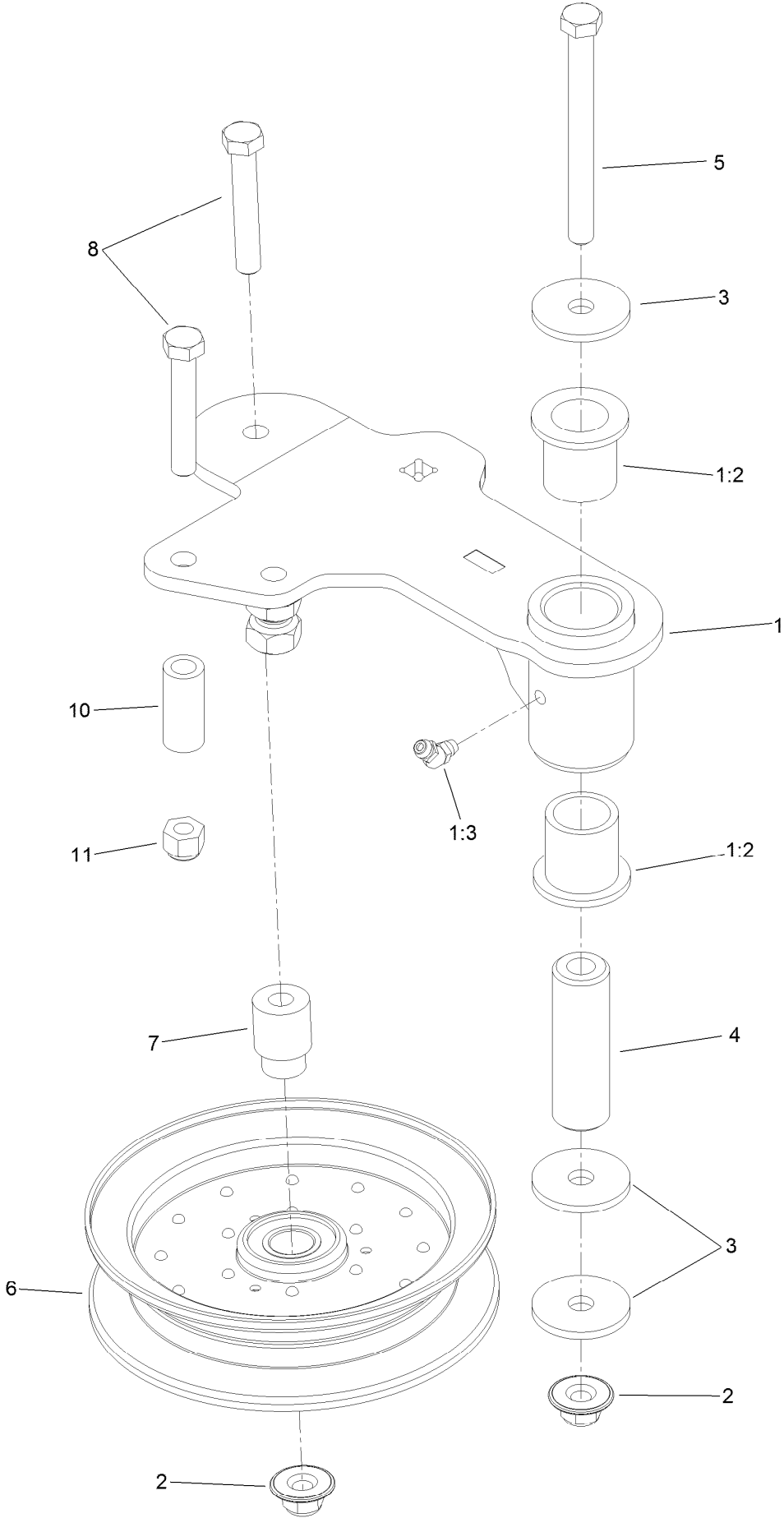

Idler Assembly (continued)

<i>Ref.</i>	<i>Part Number</i>	<i>Qty.</i>	<i>Description</i>	<i>Ref.</i>	<i>Part Number</i>	<i>Qty.</i>	<i>Description</i>
1	120-2501	1	Idler Arm ASM	5	98-5961	1	Screw-HH
1:2	1-303514	2	Bearing-Flanged	6	116-4668	1	Idler-Pulley, Flanged
1:3	1481	1	Fitting-Grease	7	112-4212	1	Mount-Pulley
2	109-6658	2	Nut-Flange, NI	8	323-11	2	Screw-HH
3	1-213069	3	Washer	10	104-0151	1	Spacer
4	114-5848	1	Spacer-Plain	11	3296-39	1	Nut-Lock, NI

Electrical Assembly

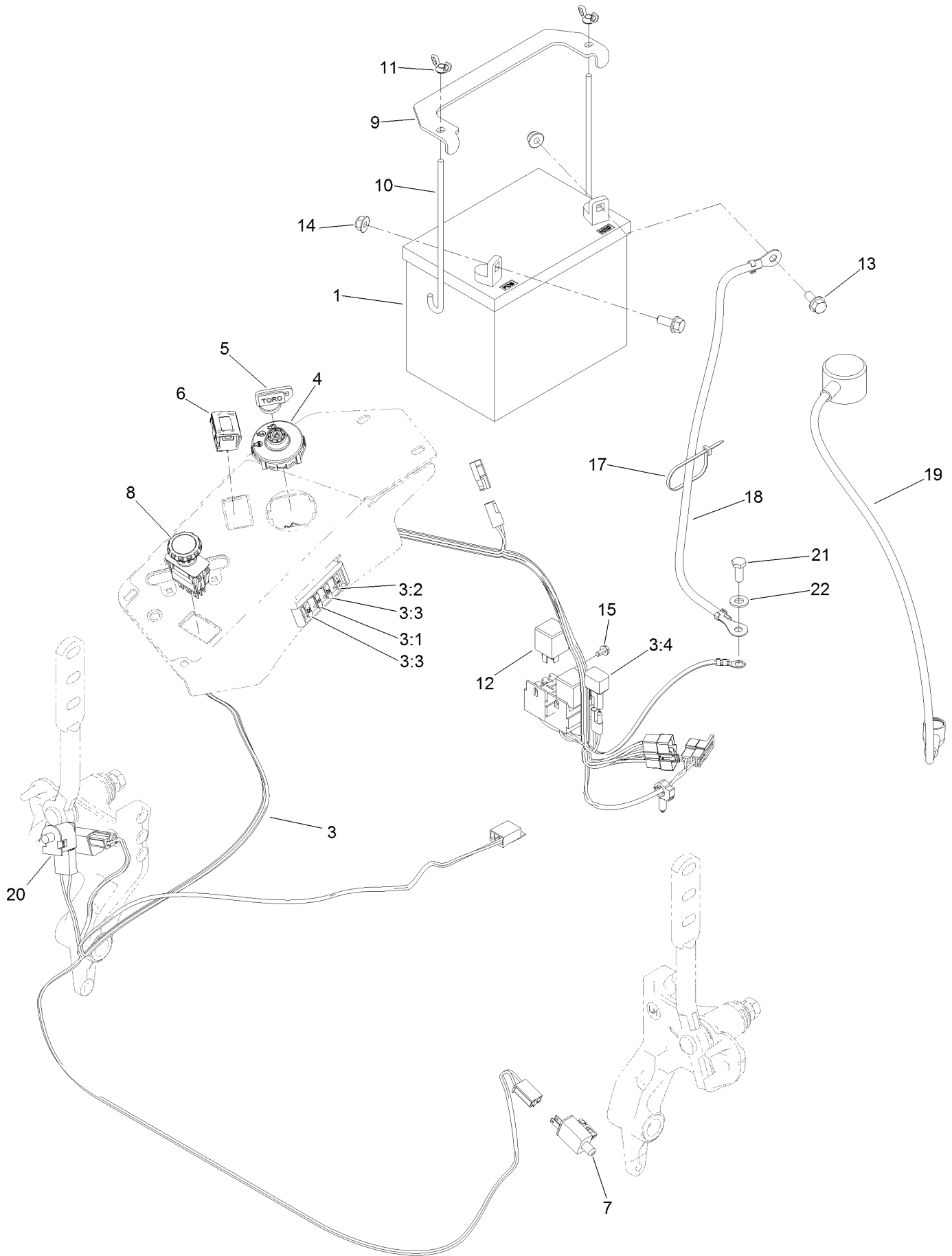

Electrical Assembly (continued)

<i>Ref.</i>	<i>Part Number</i>	<i>Qty.</i>	<i>Description</i>	<i>Ref.</i>	<i>Part Number</i>	<i>Qty.</i>	<i>Description</i>
1	104-8162	1	Battery-Dry	10	1-633651	2	Bolt-Holddown
3	117-2582	1	Harness-Wire	11	1-543792	2	Wingnut
3:1	218-578	1	Fuse-Blade, 10 Amp	12	1-643275	2	Relay
3:2	109355	1	Fuse-Blade, 15 Amp	13	3234-5	2	Screw-HHF
3:3	109102	2	Fuse-Blade, 25 Amp	14	104-8300	2	Nut-Flange, NI
3:4	116-0053	1	Cap-Plug	15	104-2065	1	Screw-HWH
4	117-2221	1	Switch-Ignition	17	1-303287	3	Tie-Cable
5	63-8360	1	Key-Ignition	18	114-1218	1	Cable-Battery, Negative
6	120-2244	1	Hourmeter	19	115-3864	1	Cable-Battery, Positive
7	110-6765	2	Switch	20	82-2190	1	Switch-Bail
8	116-0124	1	Switch-PTO, 10A	21	33114-020	1	Screw-HH
9	116-0042-03	1	Strap-Tie Down, Battery	22	33094-00	1	Washer-Plain

Attachments and Accessories

For 74145 Z Master Commercial 2000 Series Riding Mower with 60in TURBO FORCE Side Discharge Mower

Product Name	Model/Part
Turbo Baffle Kit	107-1634
Hypr-Oil 500 (quart)	114-4713
Hypr-Oil 500 (gallon).....	114-4714
Hypr-Oil 500-5 (5 gallon).....	114-4715
Bimini Folding Shade Assembly	115-4510
Blade-mulch, 20.50in	115-5002-03
Blade-hi Flo, 20.5in	115-9649-03
Light Kit.....	116-1154
Operator Controlled Discharge Chute Kit.....	117-3600
Recycler Kit	120-2403
Z Stand Kit.....	121-4811
Deluxe Seat Kit	121-7595
MVP Belt and Blade Kit.....	127-1633
Toro Deluxe Rider Cover.....	490-7319
Spark Arrestor Screen	75-6880
E-Z VAC Twin Soft Bagger.....	78569
Blower and Drive Kit	78573
Filter Minder Gauge	99-4664
Trash Holder Kit.....	TC26

Notes:

Notes:

Notes:



Count on it.