

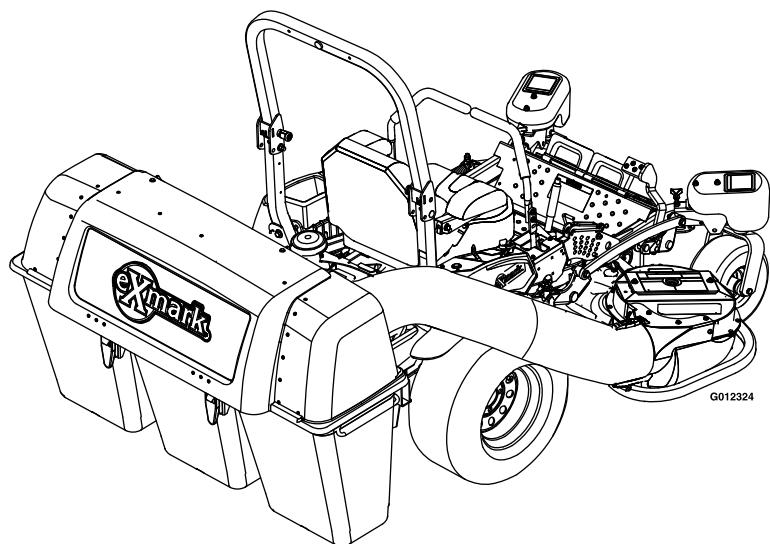

# ULTRA VAC®

Model No. LZUV2B—Serial No. 31500000 and Up

Picture below may not reflect actual product.



G012324

# Parts Manual

# Ordering Replacement Parts

To order replacement parts, please supply the part number, the quantity, and the description of each part desired.

## Understanding Reference Numbers

Each identified part in an illustration has a reference number. The reference number for a part also appears in the parts list, along with other information about the part.

This catalog uses two special reference number formats, one to indicate parts in a service assembly and another to indicate the quantity of a given part in an illustration.

## Service Assembly Reference Numbers

Parts in service assemblies have reference numbers in the form a:b. The a represents the reference number of the entire service assembly and the b represents a sequential number unique to each part within the service assembly.

For example, a wheel assembly might be identified by reference number 6, the tire by 6:1, the valve by 6:2, and the wheel by 6:3. When you order the assembly identified by reference number 6, you receive all parts identified by reference numbers 6:1, 6:2, and 6:3. However, you may also order any part individually. Reference numbers of this type appear in illustration and in parts lists.

## Reference Numbers Indicating Quantity

In an illustration, if a reference number indicates more than one part, the reference number has the form nX y. The n represents the quantity of the part, the X is the multiplication symbol, and the y represents the reference number.

For example, in an illustration, the reference number 2X 37 means that two of the parts identified by reference number 37 are indicated.

# List of Abbreviations

<b>AR:</b> as required	<b>HLH:</b> hex lag head	<b>PTH:</b> phillips truss head
<b>ASM:</b> assembly	<b>HOC:</b> height-of-cut	<b>PTO:</b> power-take-off
<b>BBC:</b> blade brake control	<b>HP:</b> high pressure	<b>RH:</b> right hand
<b>BHTF:</b> button head thread forming	<b>HSBH:</b> hex socket button head	<b>ROPS:</b> roll-over protection system
<b>CARR:</b> carriage	<b>HSFH:</b> hex socket flat head	<b>RRB:</b> rear roller brush
<b>CCW:</b> counter clockwise	<b>HSH:</b> hex socket head	<b>SFH:</b> slotted fillister head
<b>CW:</b> clockwise	<b>HWH:</b> hex washer head	<b>SHH:</b> slotted hex head
<b>DEG:</b> degrees	<b>HWHTF:</b> hex washer head thread forming	<b>SHWH:</b> slotted hex washer head
<b>DPA:</b> Dual Point Adjustment	<b>HYD:</b> hydraulic	<b>SPH:</b> slotted pan head
<b>ECM:</b> electronic control module	<b>LH:</b> left hand	<b>SQH:</b> square head
<b>EXT:</b> external	<b>LP:</b> low pressure	<b>SRH:</b> slotted round head
<b>FH:</b> flat head	<b>LPG:</b> Liquefied Petroleum Gas	<b>STD:</b> standard
<b>GA:</b> gauge	<b>NI:</b> nylon insert	<b>TAP:</b> self tapping
<b>HD:</b> heavy-duty	<b>NPTF:</b> national pipe thread fine	<b>TTH:</b> torx truss head
<b>HF:</b> hex flange	<b>PFH:</b> phillips flat head	
<b>HH:</b> hex head	<b>PPH:</b> phillips pan head	
<b>HHF:</b> hex head flange	<b>PPHTF:</b> phillips pan head thread forming	
<b>HHFTF:</b> hex head flange thread forming	<b>PRH:</b> phillips round head	
<b>HJ:</b> hex jam		

# Touch Up Paint

Exmark black touch up spray paint – gloss black.

Exmark red touch up paint (spray paint – P/N 1-850337 - .6 oz liquid bottle – P/N 103-9140).



If your Exmark dealer does not have the Exmark part in stock, Exmark will get the parts to the dealer the next business day or the part will be FREE Guaranteed!! (Some restrictions apply. See your participating Exmark Dealer for details.)

## Contents

LZUV2B Assembly .....	4
Hood and Frame Assembly No. 109-5941 .....	5
Hood Assembly No. 1-654597 .....	6
Idler Assembly .....	7
Lower Tube Assembly No. 109-2043 .....	8
Bag Support Frame Assembly No. 103-5166 .....	9
Bag Assembly No. 116-0754 .....	10
Blower Assembly No. 109-9832 .....	11
Completing Kit No. 109-9622 .....	13
Completing Kit No. 109-9623 .....	14
Completing Kit No. 109-9624 .....	15
Completing Kit No. 109-9625 .....	16
Completing Kit No. 116-2084 .....	17
Completing Kit No. 116-2085 .....	18

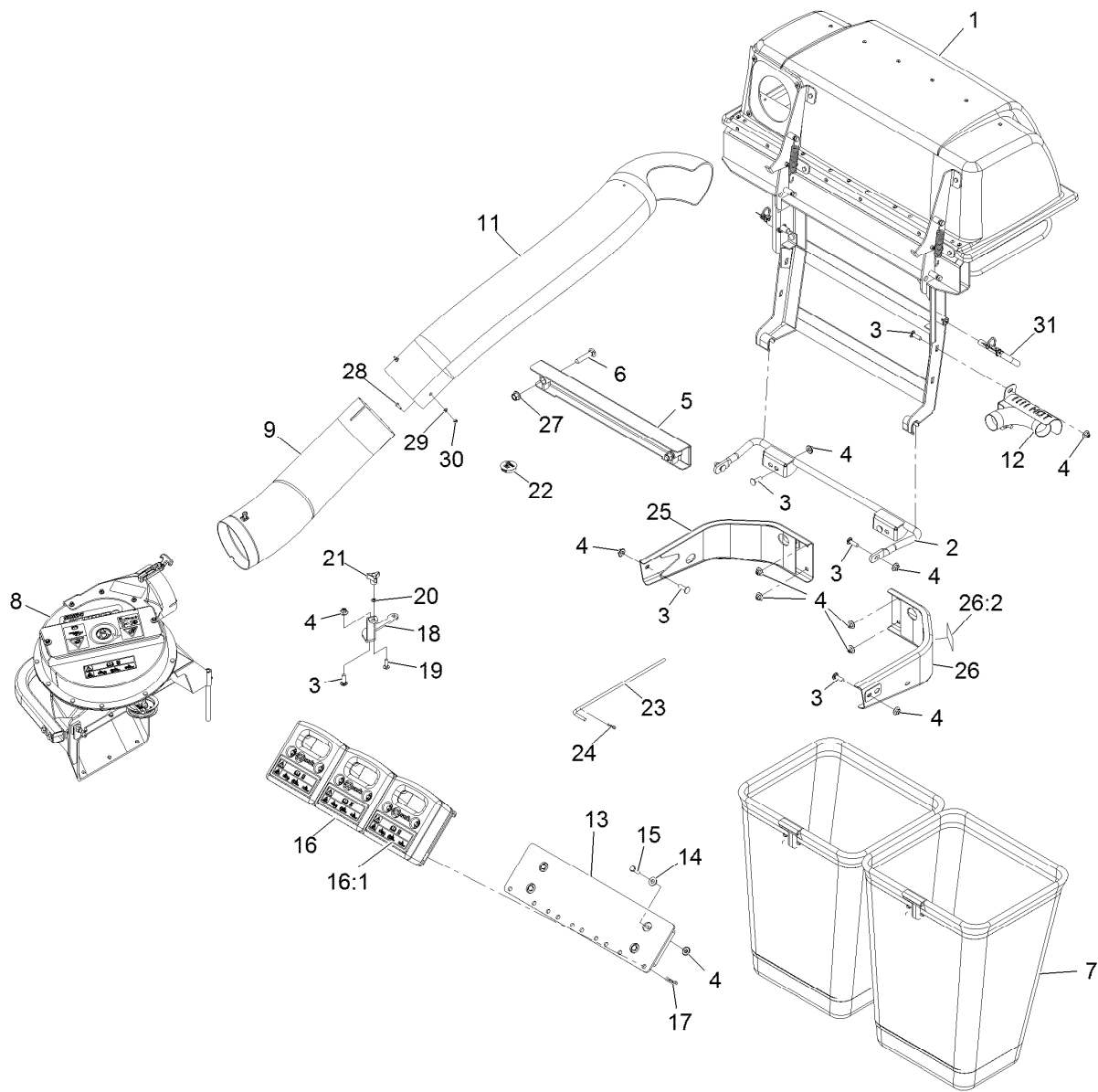

## LZUV2B Assembly

Ref.	Part Number	Qty.	Description	Ref.	Part Number	Qty.	Description
1		1	ASM,Hood Uv 2-Bag ●	16:1	126-4661	1	Decal-Warning Weight
2	109-9248	1	Mount-Bagger, Lower	17	9335124	6	Hairpin-Cotter
3	3231-28	10	Bolt-Carriage 3/8-16 X 1 1/4	18	116-0161-01	1	Bracket, Small Uv Belt Cover
4	109-6658	18	Nut-Nyloc 3/8-16 Flg	19	3230-2	1	Bolt-Carriage 5/16-18 X 1
5	116-0473-03	1	Mount-Bagger, Upper	20	109-5667	1	Ring-Bolt Retaining
6	3233-34	2	Bolt-Carriage 1/2-13 X 2 1/2	21	1-323385	1	Knob-3 Prong
7	116-0754	2	Bag And Frame ASM	22	103-1279	1	Plug
8	109-9832	1	ASM, Blower Small - Svc Only	23	109-3458	1	Pin, Chute Pivot
9	109-2043	1	Lower Tube ASM	24	1-806003	1	Hairpin-Cotter
11	109-2036	1	Tube-Upper	25	116-0057-03	1	Bumper-RH
12	116-2804	1	Exhaust Diverter ASM	26	116-0180	1	LH Bumper ASM
13	116-1129-01	1	Wld, Mount Toeboard Weight	26:2	106-5517	1	Decal-Warning, Hot Surface
14	3256-4	4	Washer-3/8 Std	27	99-5107	2	Nut-Lock 1/2-13
15	323-7	4	Screw-HH 3/8-16 X 1 1/4	28	32105-13	3	Screw-HWH #10-24 X 3/4
16	103-6363	3	Asm, Weight (103-6364-01) W/Decals	29	3256-14	3	Washer-#10 Std
				30	3296-2	3	Nut-Nyloc #10-24
				31	116-0458	2	Bagger Mount Pin ASM

● Not serviced separately

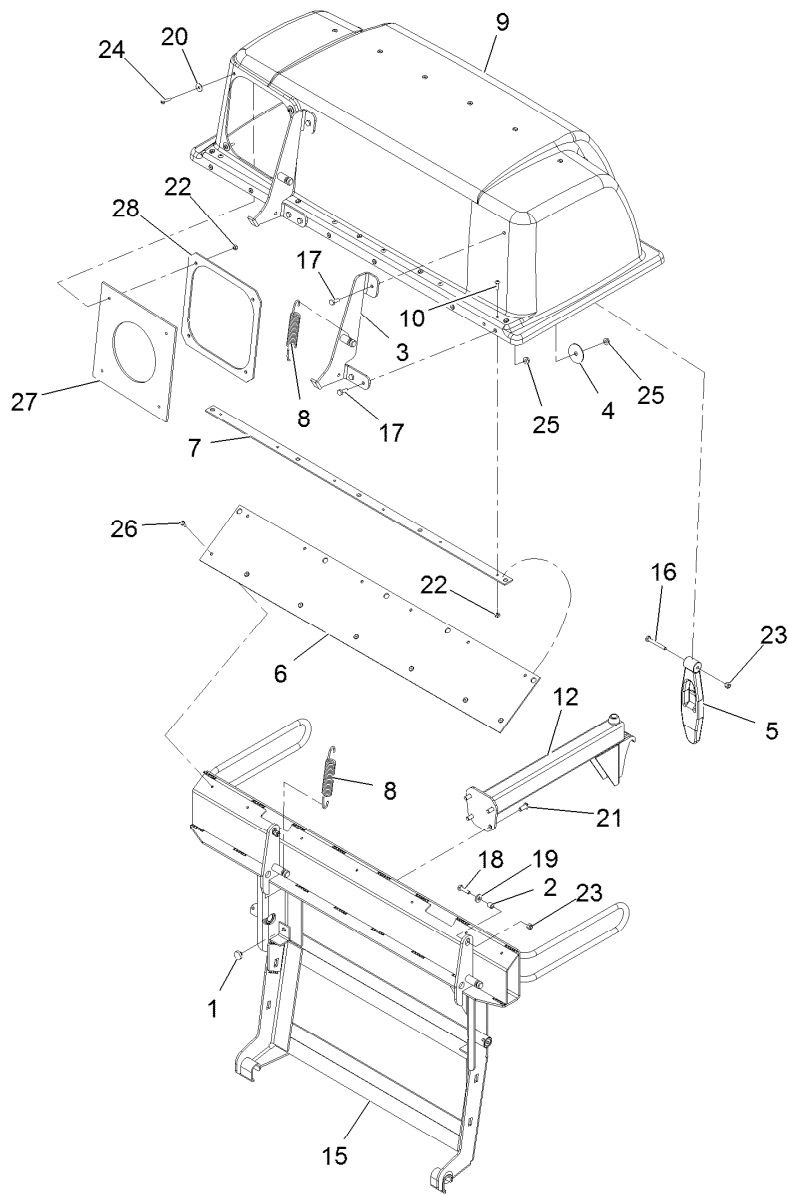

## Hood and Frame Assembly No. 109-5941

<i>Ref.</i>	<i>Part Number</i>	<i>Qty.</i>	<i>Description</i>	<i>Ref.</i>	<i>Part Number</i>	<i>Qty.</i>	<i>Description</i>
1	1-513658	2	Bumper	16	321-11	1	Screw-HH 1/4-20 X 2
2	1-633545	2	Spacer	17	321-4	6	Screw-HH 1/4-20 X 3/4
3	1-652395-03	2	Hinge ASM	18	321-6	2	Screw-HH 1/4-20 X 1
4	1-653036	2	Washer	19	3256-2	2	Washer-1/4 Std
5	1-653403	1	Latch	20	3256-61	4	Washer
6	1-653425	1	Seal	21	3274-55	4	Screw-Button Head 5/16-18 X 3/4
7	1-653528-03	1	Plate-Backing	22	3296-2	10	Nut-Nyloc #10-24
8	1-653544	2	Spring-Extension	23	3296-42	3	Nut-Nyloc 1/4-20
9	1-654597	1	Hood Assembly - Service Only	24	3250-27	4	Screw-PPH #10-24 X 7/8
10	1-803075	6	Screw-Truss Head #10-24 X 3/4	25	32128-33	6	Nut-Whizlock 1/4-20
12	103-5166	1	Bag Support ASM	26	114439	7	Rivet
15	109-8705-03	1	Frame-2-Bag, Uv	27	1-653561	1	Seal-Chute
				28	1-653598-03	1	Clamp-Seal

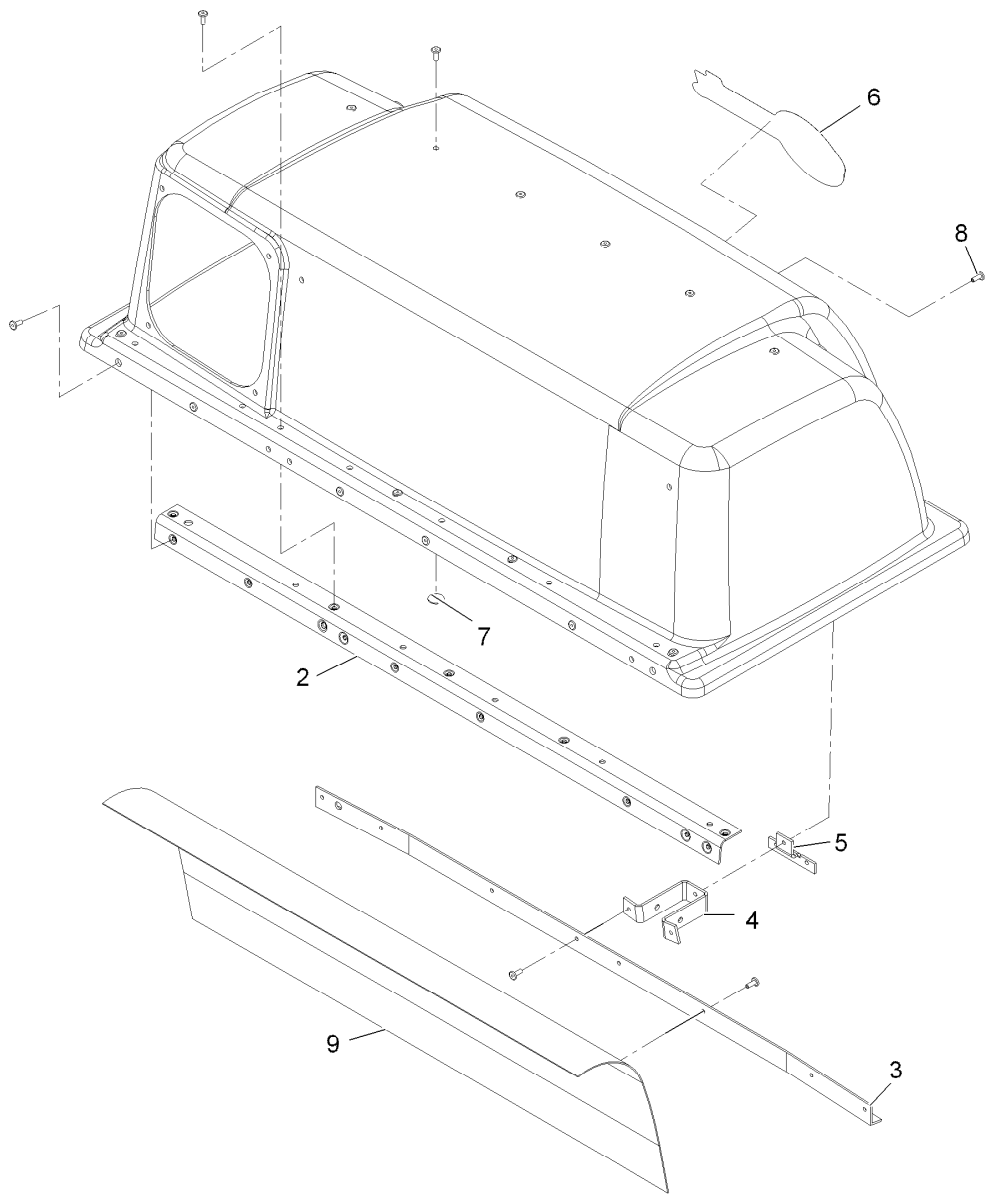

## Hood Assembly No. 1-654597

<i>Ref.</i>	<i>Part Number</i>	<i>Qty.</i>	<i>Description</i>
2	1-653397-03	1	Stiffener-Bagger, Top
3	1-653400-03	1	Support-Screen
4	1-653519	1	Anchor-Latch
5	1-653535	1	Reinforcement-Latch
6	1-653546	1	Decal, Exmark
7	3256-61	10	Washer
8	114439	31	Rivet
9	114967	1	Screen-Bagger

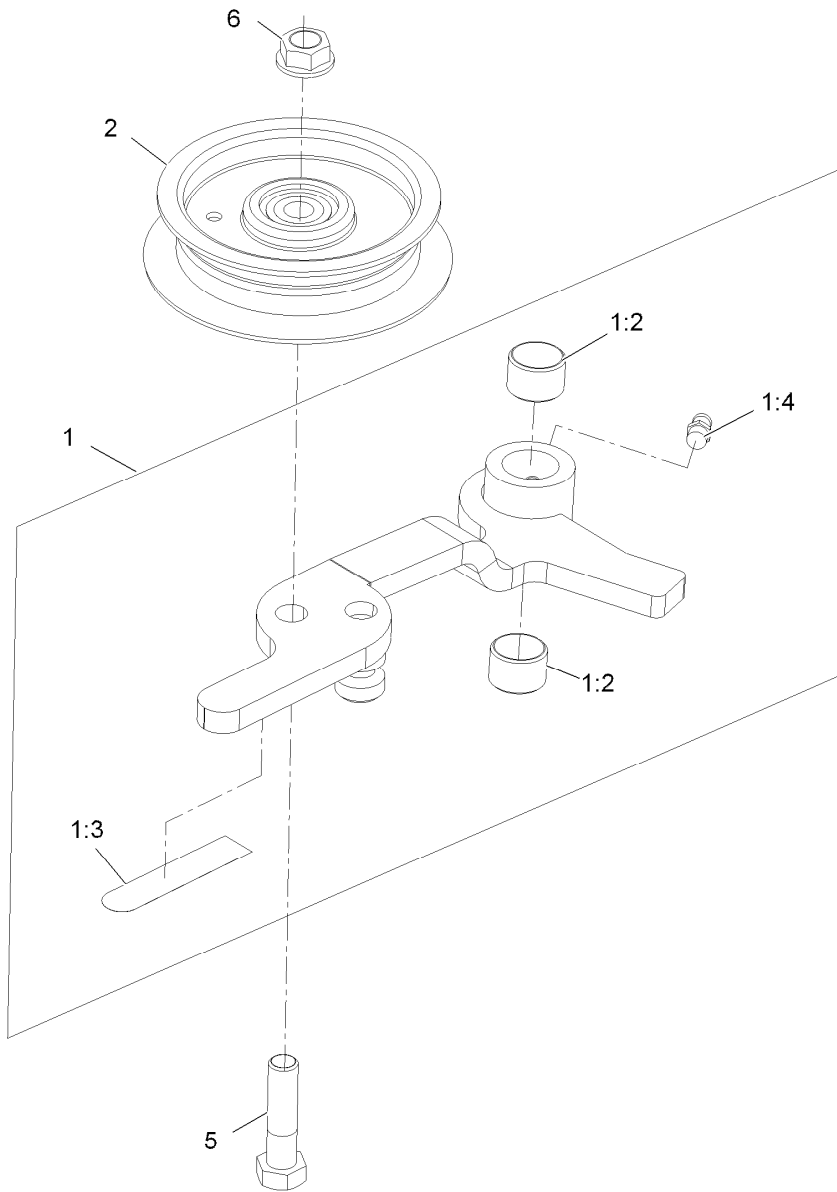

## Idler Assembly

<b>Ref.</b>	<b>Part Number</b>	<b>Qty.</b>	<b>Description</b>
1	103-2876	1	Idler Assy With Bushings, Zerk, And Decal
1:2	1-653600	2	Bearing
1:3	126-4659	1	Decal-Warning Hot Pulley
1:4	302-19	1	Zerk-1/4-28 Str
2	103-1103	1	Idler-Flat
5	323-8	1	Screw-HH 3/8-16 X 1 1/2
6	3290-357	1	Nut-Whizlock 3/8-16

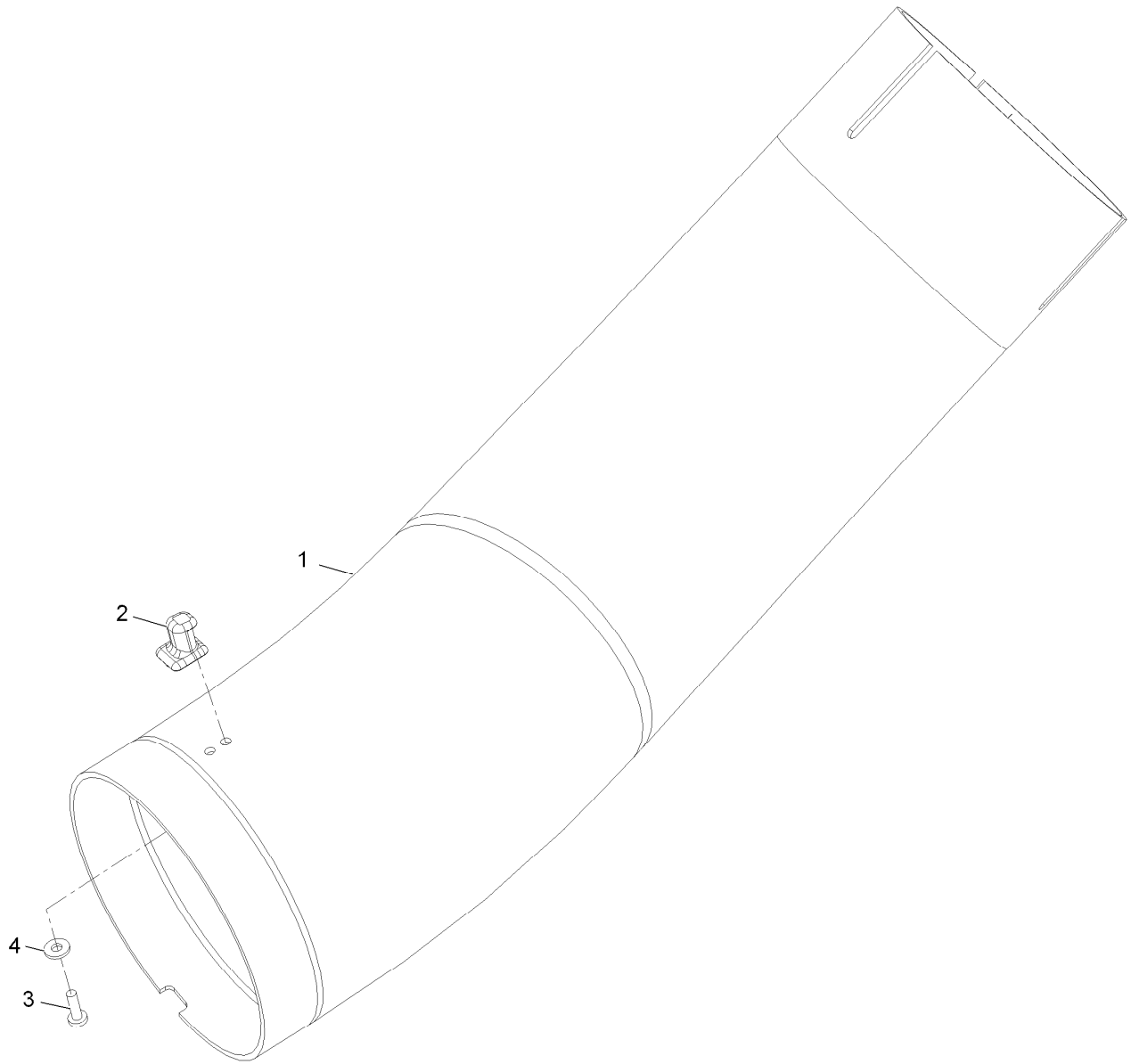

## Lower Tube Assembly No. 109-2043

<i>Ref.</i>	<i>Part Number</i>	<i>Qty.</i>	<i>Description</i>
1	109-2038	1	Tube, Lower Short
2	103-4081	2	Latch-Keeper ●
3	3290-500	2	Screw-PPH #10-24 X 5/8
4	3256-14	2	Washer-#10 Std

● Kit No. 103-4188 - Contains catch, rubber latch, and mounting hardware

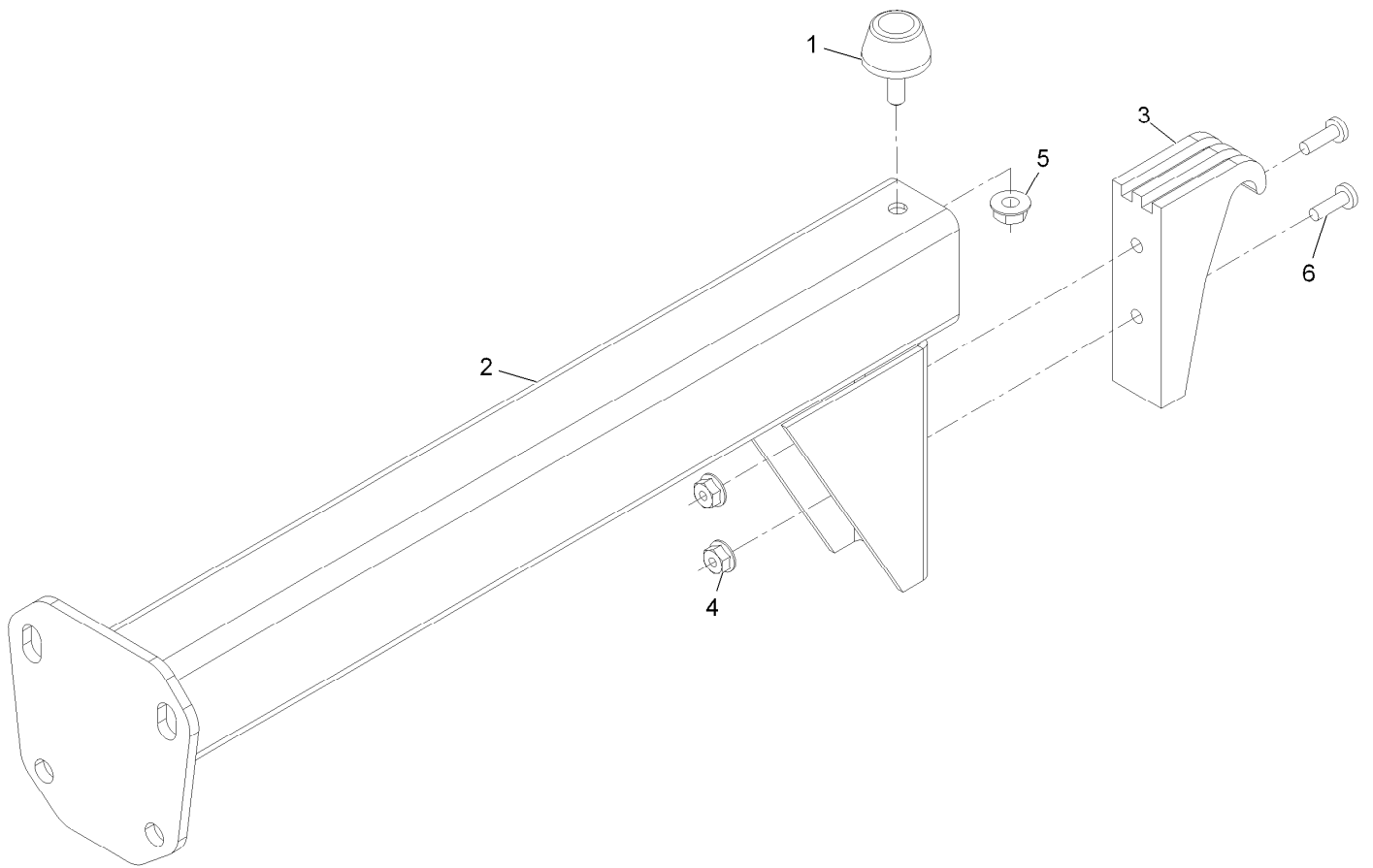

## Bag Support Frame Assembly No. 103-5166

<i>Ref.</i>	<i>Part Number</i>	<i>Qty.</i>	<i>Description</i>
1	1-523420	1	Bumper
2	103-5124-03	1	Support-Bag
3	1-653404	1	Catch
4	3290-148	2	Nut-Whizlock #10-24
5	32128-33	1	Nut-Whizlock 1/4-20
6	3290-500	2	Screw-PPH #10-24 X 5/8

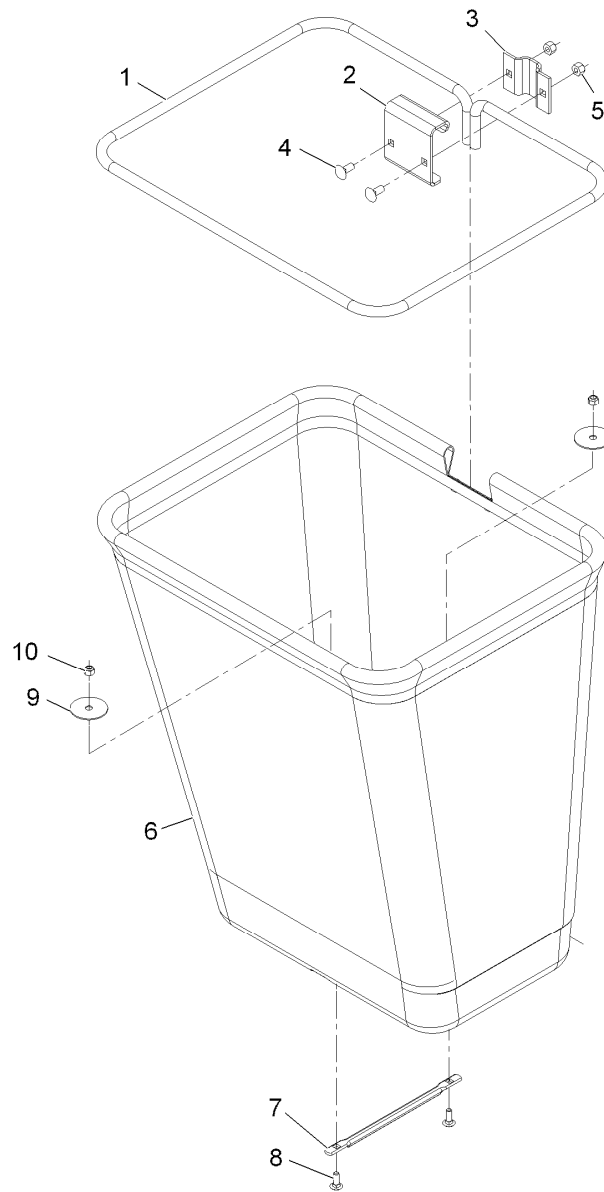

## Bag Assembly No. 116-0754

Ref.	Part Number	Qty.	Description
1	1-653529-03	1	Frame-Bag
2	114973-03	1	Hanger-Bag
3	114974-03	1	Clamp
4	3230-1	2	Bolt-Carriage 5/16-18 X 3/4
5	3296-29	2	Nut-Nyloc 5/16-18
6	116-0757	1	Bag ASM
7	1-653566	1	Handle-Bag
8	3229-1	2	Bolt-Carriage 1/4-20 X 3/4
9	1-653036	2	Washer
10	3296-42	2	Nut-Nyloc 1/4-20

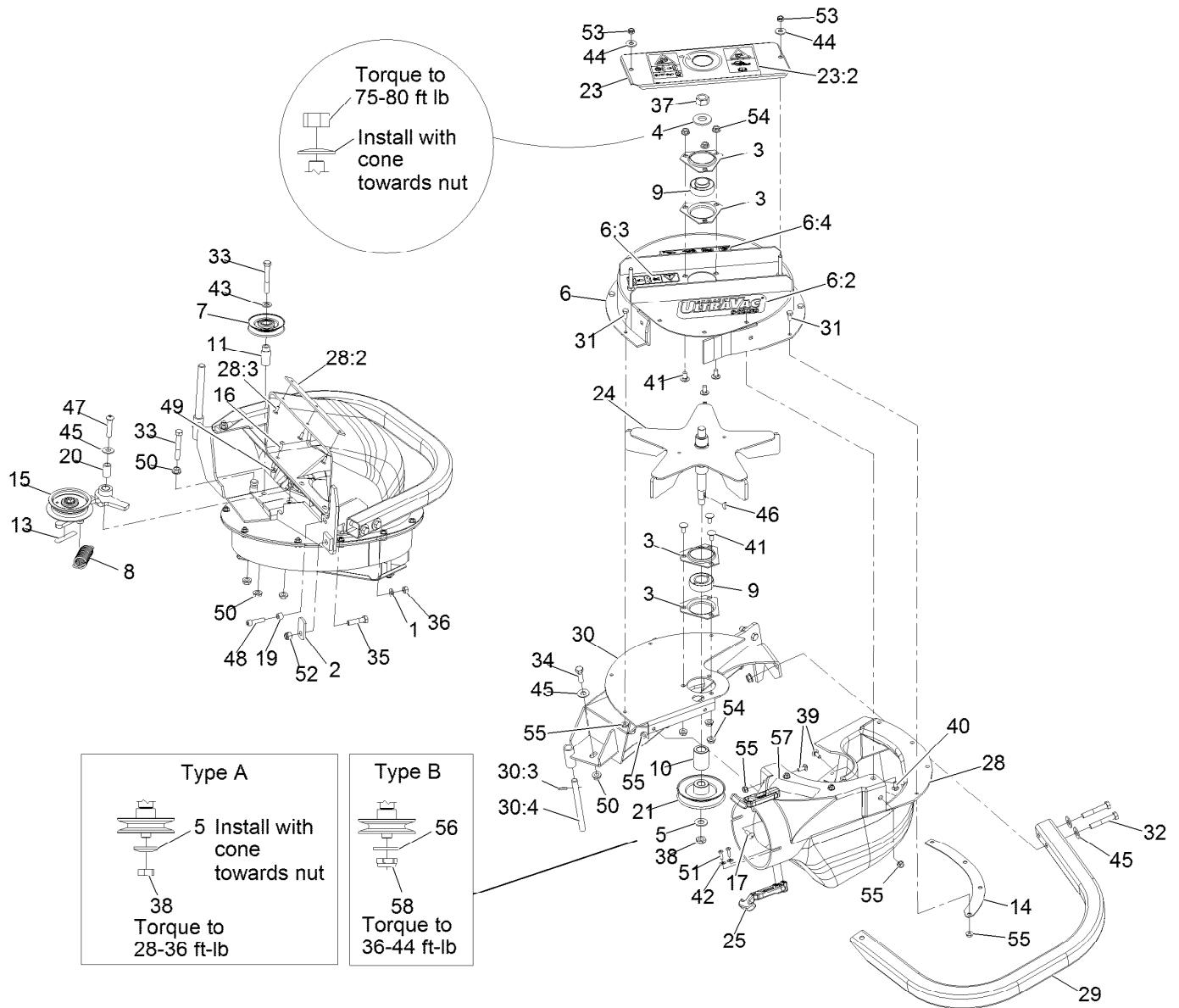

## Blower Assembly No. 109-9832

Ref.	Part Number	Qty.	Description	Ref.	Part Number	Qty.	Description
1	1-303334	1	Washer-Spring Disc 5/16	16	1-803075	3	Screw-Truss Head #10-24 X 3/4
2	1-353054	1	Latch-Catcher, Grass	17	1-803076	2	Screw-PPH 1/4-20 X 3/4
3	1-513013	4	Housing-Flange	19	103-0126	1	Bushing
4	1-513208	1	Washer-Spring Disc 5/8	20	103-0130	1	Bushing-Pivot, Idler
5	3256-26	1	Washer-1/2 Sae	21	103-1047	1	Sheave-Blower ▲
6	116-4817	1	ASM-Upper Housing Small	23	103-3585	1	Cover, Bearing
6:2	116-4789	1	Decal-Ultra Vac S-Series	23:2	126-4584	1	Decal-Warning
6:3	112-9028	1	Decal-Cover Missing	24	103-3815	1	Impeller
6:4	126-4661	1	Decal-Warning Weight	25	103-4080	2	Latch-Rubber ■
7	1-653322	1	Idler-Inside	28	109-1985	1	Chute, Blower (46, 50 And 56)
8	1-653331	1	Spring	28:2	103-4752-03	1	Plate, Reinforcing (Below S/N 260,000)
9	1-653346	2	Bearing ▲	28:3	114439	3	Rivet
10	1-653365	1	Spacer	29	109-1122-01	1	Bumper
11	1-653366	1	Spacer	30	109-9362-03	1	Weld, Frame Sm Blower
13	126-4659	1	Decal-Warning Hot Pulley				
14	1-653596-03	1	Plate-Backing, Blower				
15		1	ASM, Idler ●				

● Not serviced separately

■ Kit No. 103-4188 - Contains catch, rubber latch, and mounting hardware

▲ Apply Mobil HTS grease (P/N 103-5217 1.5 oz packet) (or a food-grade anti-seize). See operator s manual for locations.

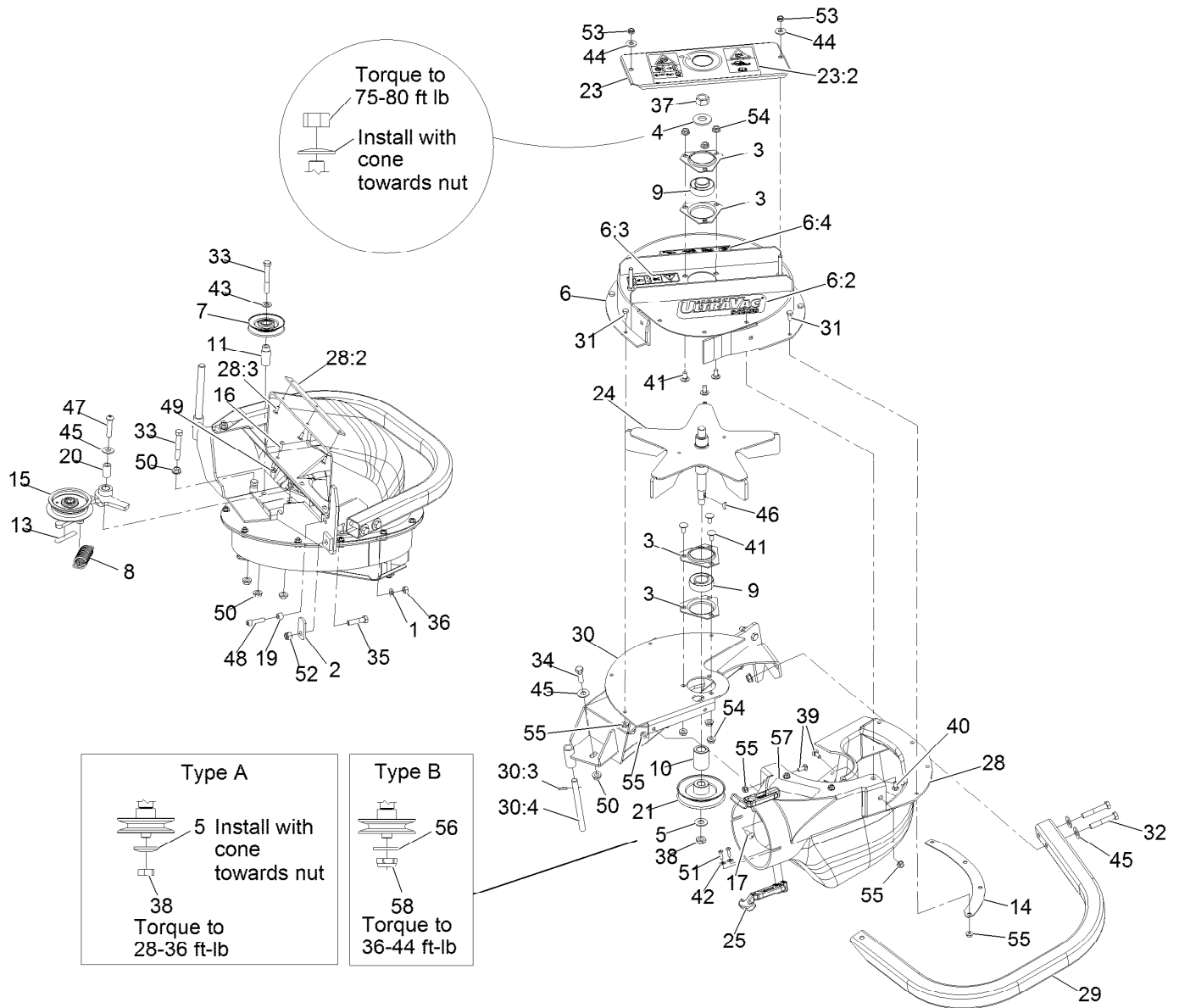

## Blower Assembly No. 109-9832 (continued)

Ref.	Part Number	Qty.	Description	Ref.	Part Number	Qty.	Description
30:3	1-806323	1	Rollpin 3/16 X 7/8	45	3256-4	4	Washer-3/8 Std
30:4	1-353050	1	Shaft-Catcher, Grass	46	3257-32	1	Key-Woodruff 3/16 X 5/8
31	321-3	8	Screw-HH 1/4-20 X 5/8	47	3274-107	1	Screw-Button Head 3/8-16 X 1 3/4
32	323-11	2	Screw-HH 3/8-16 X 2 1/4	48	3274-18	1	Screw-Sh 5/16-18 X 1 1/4
33	323-12	2	Screw-HH 3/8-16 X 2 1/2	49	3290-148	3	Nut-Whizlock #10-24
34	323-7	1	Screw-HH 3/8-16 X 1 1/4	50	3290-357	7	Nut-Whizlock 3/8-16
35	323-8	1	Screw-HH 3/8-16 X 1 1/2	51	3290-500	4	Screw-PPH #10-24 X 5/8
36	3217-6	1	Nut-Hex 5/16-18	52	3296-39	1	Nut-Nyloc 3/8-16
37	3219-6	1	Nut-Hex 5/8-18	53	3296-47	2	Nut-Nyloc 5/16-18 Thin
38	3296-28	1	Nut-Lock, NI	54	32128-20	6	Nut-Whizlock 5/16-18
39	3229-1	2	Bolt-Carriage 1/4-20 X 3/4	55	32128-33	15	Nut-Whizlock 1/4-20
40	3229-11	3	Bolt-Carriage 1/4-20 X 5/8	56	3256-26	1	Washer-Flat
41	3230-18	6	Bolt-Carriage 5/16-18 X 5/8	57	126-4853	1	Decal-Blower-Impeller Hazard
42	3256-14	4	Washer-#10 Std	58	3296-28	1	Nut-Lock, NI
43	3256-24	1	Washer-3/8 Sae				
44	3256-3	2	Washer-5/16 Std				

● Not serviced separately

■ Kit No. 103-4188 - Contains catch, rubber latch, and mounting hardware

▲ Apply Mobil HTS grease (P/N 103-5217 1.5 oz packet) (or a food-grade anti-seize). See operator s manual for locations.

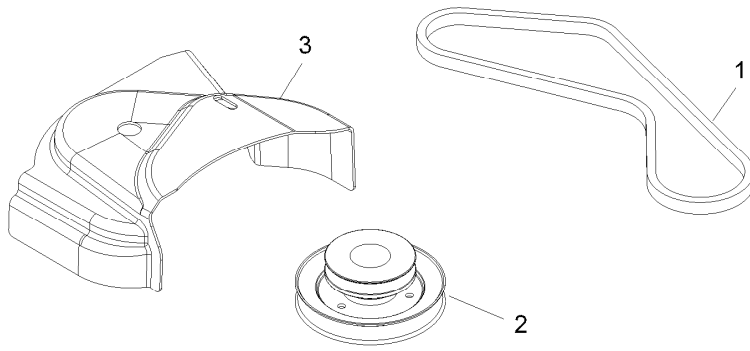

Completing kit fits all  
Lazer Z Advantage Series (LZAS)  
Serial Nos. 790,000-919,999  
with 48 inch decks

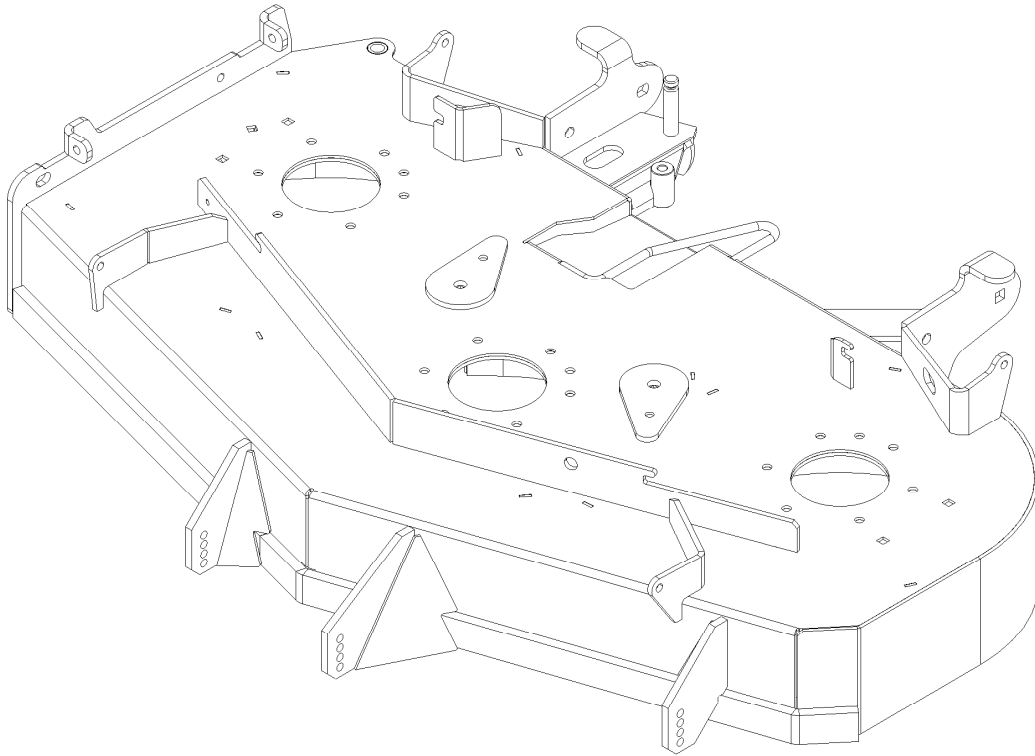

## Completing Kit No. 109-9622

<i>Ref.</i>	<i>Part Number</i>	<i>Qty.</i>	<i>Description</i>
1	1-653333	1	Belt, Blower (48")
2	116-1649	1	Jackshaft,Uv Drive 484
3	109-9382	1	Cover,Belt Uv 48

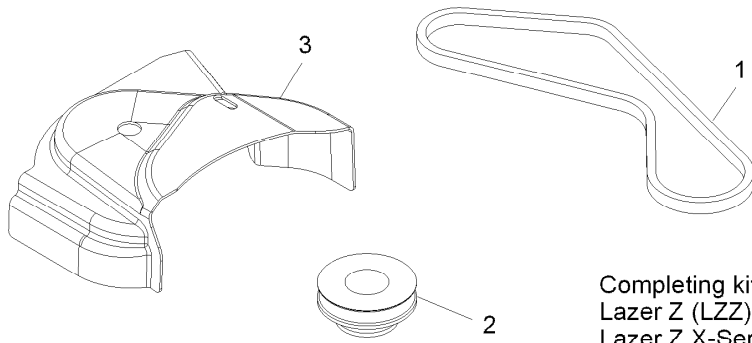

Completing kit fits all  
 Lazer Z (LZZ) Serial Nos. 790,000-919,999 and  
 Lazer Z X-Series (LZX) Serial Nos. 920,000 and Higher  
 with 48 inch decks

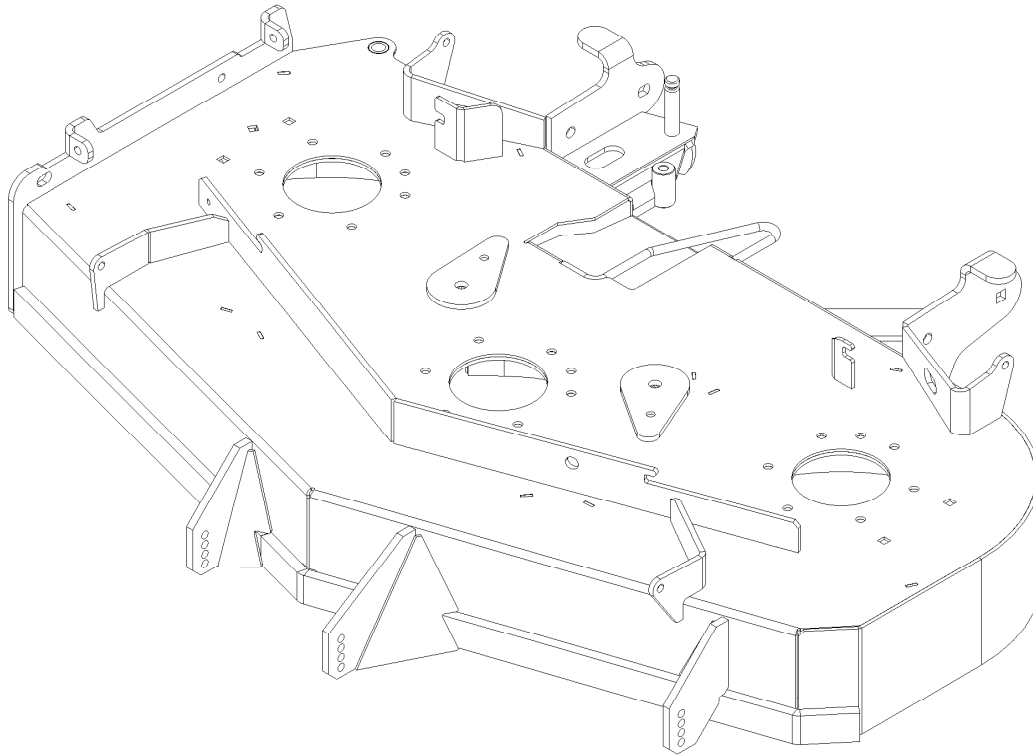

## Completing Kit No. 109-9623

<i>Ref.</i>	<i>Part Number</i>	<i>Qty.</i>	<i>Description</i>
1	1-653333	1	Belt, Blower (48")
2	109-9631	1	Blade, Extreme 72
3	109-9382	1	Cover,Belt Uv 48

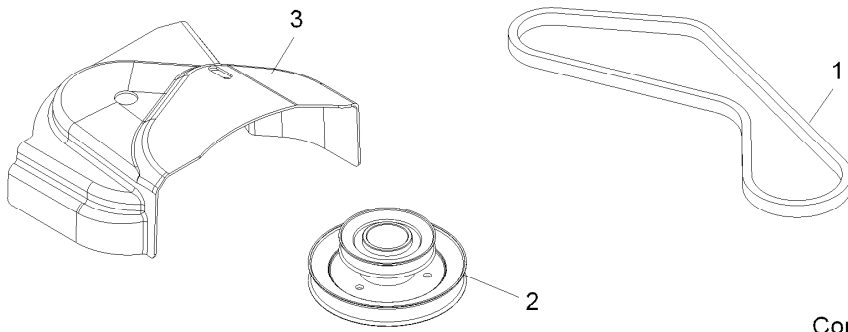

Completing kit fits all  
 Lazer Z Advantage Series (LZAS)  
 Serial Nos. 790,000-919,999  
 with 52 inch decks

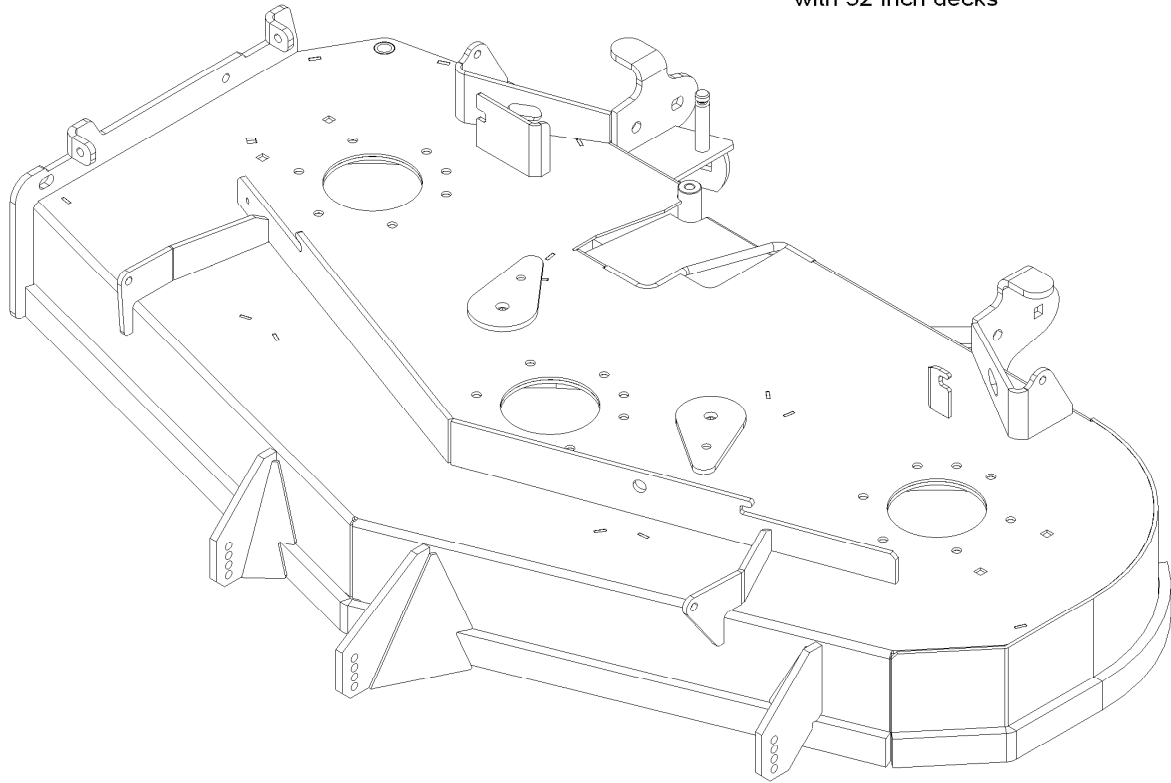

## Completing Kit No. 109-9624

<i>Ref.</i>	<i>Part Number</i>	<i>Qty.</i>	<i>Description</i>
1	1-653438	1	Belt, Blower Drive 52
2	109-9632	1	Sheave
3	109-8487	1	Cover,Belt Uv 52

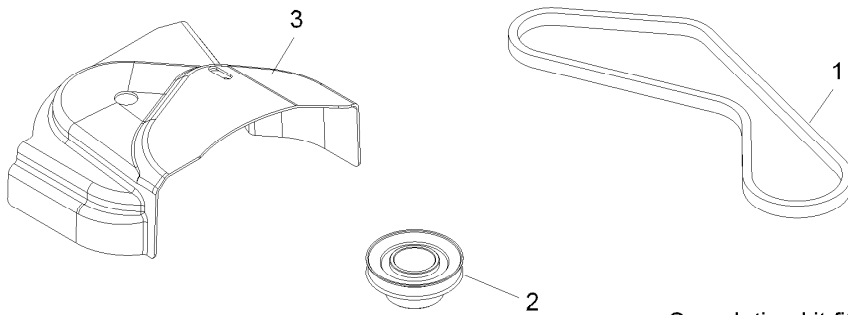

Completing kit fits all  
 Lazer Z (LZZ) Serial Nos. 790,000-919,999 and  
 Lazer Z X-Series (LZX) Serial Nos. 920,000  
 and Higher with 52 inch decks

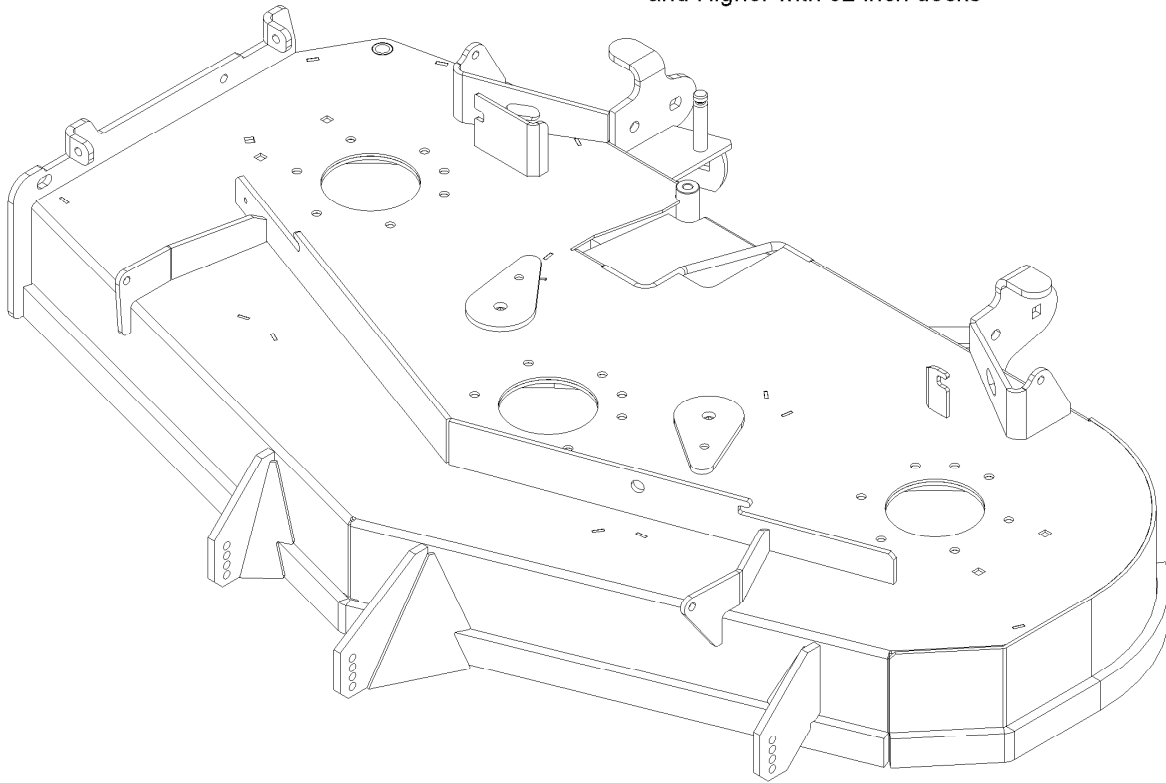

## Completing Kit No. 109-9625

<i>Ref.</i>	<i>Part Number</i>	<i>Qty.</i>	<i>Description</i>
1	1-653438	1	Belt, Blower Drive 52
2	109-9633	1	Sheave, Drive Lzuv 526
3	109-8487	1	Cover, Belt Uv 52

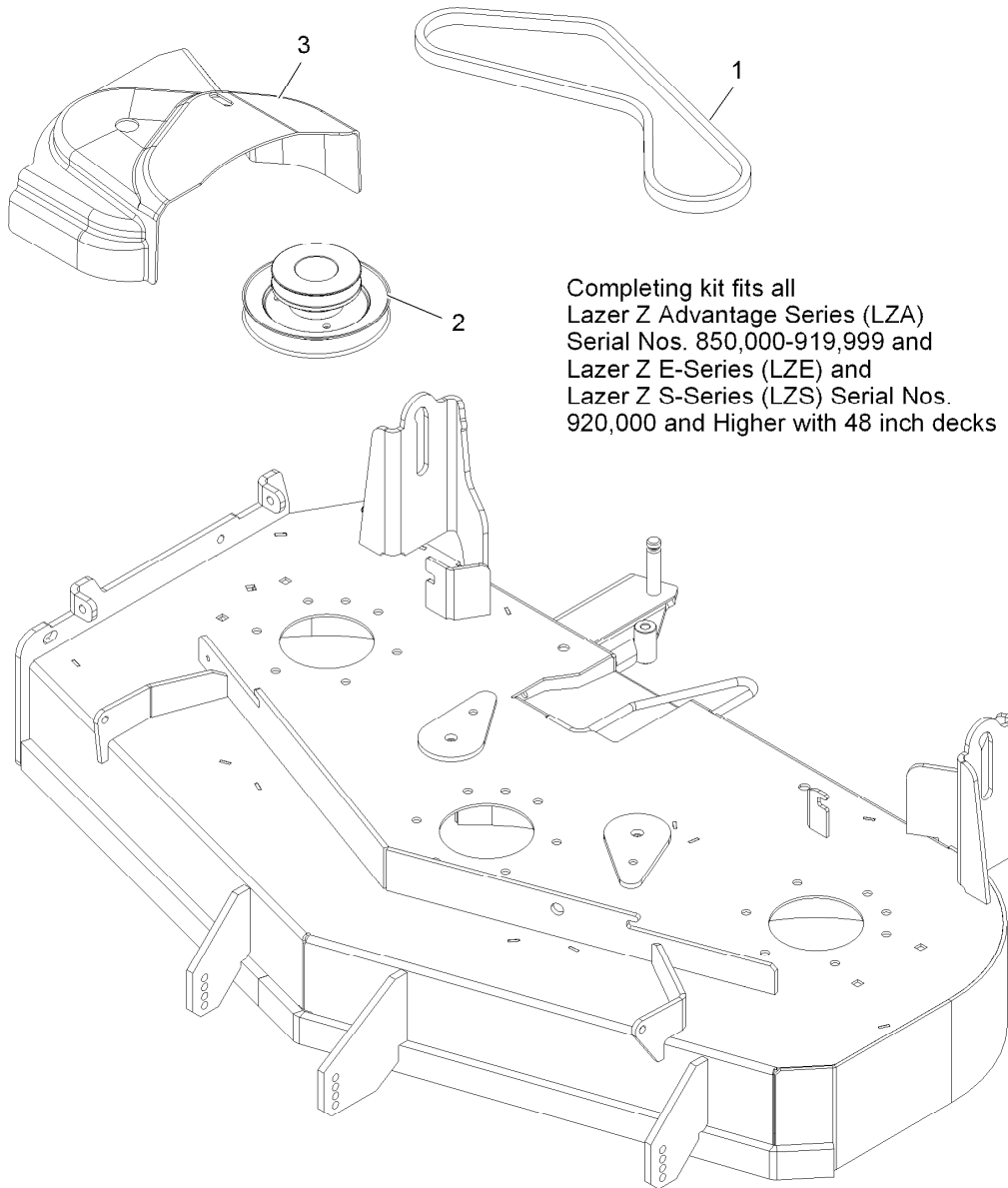

Completing kit fits all  
 Lazer Z Advantage Series (LZA)  
 Serial Nos. 850,000-919,999 and  
 Lazer Z E-Series (LZE) and  
 Lazer Z S-Series (LZS) Serial Nos.  
 920,000 and Higher with 48 inch decks

## Completing Kit No. 116-2084

<i>Ref.</i>	<i>Part Number</i>	<i>Qty.</i>	<i>Description</i>
1	1-653333	1	Belt, Blower (48")
2	116-2088	1	Jackshaft-Uv Drive, 484 Splined
3	109-9382	1	Cover,Belt Uv 48

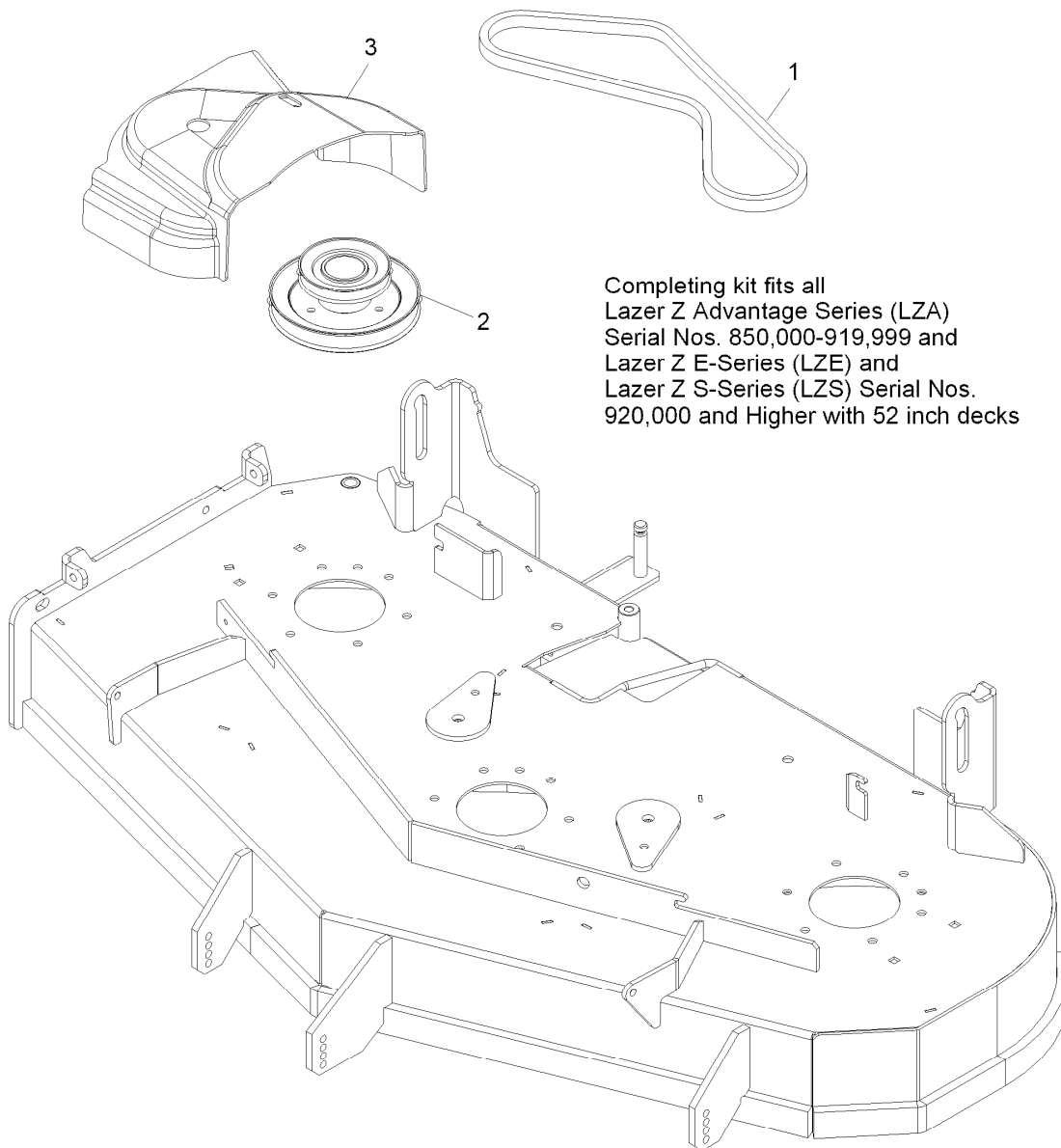

Completing kit fits all  
 Lazer Z Advantage Series (LZA)  
 Serial Nos. 850,000-919,999 and  
 Lazer Z E-Series (LZE) and  
 Lazer Z S-Series (LZS) Serial Nos.  
 920,000 and Higher with 52 inch decks

## Completing Kit No. 116-2085

<i>Ref.</i>	<i>Part Number</i>	<i>Qty.</i>	<i>Description</i>
1	1-653438	1	Belt, Blower Drive 52
2	116-2089	1	Jackshaft,Uv Drive 524 Splined
3	109-8487	1	Cover,Belt Uv 52

**Notes:**

## EXMARK ACCESSORIES AND OPTIONS\*

### MID-MOUNT RIDING ACCESSORIES AND OPTIONS

CUSTOM RIDE SEAT SUSPENSION SYSTEM	OPERATOR CONTROLLED DISCHARGE
FULL SUSPENSION SEAT	SUN SHADE
DECK LIFT ASSIST KIT	TRASH CONTAINER
HITCH KIT	TURF STRIPER
LIGHT KIT	ULTRA VAC COLLECTION SYSTEM
12V POWER PORT	ULTRA VAC QUICK DISPOSAL SYSTEM
MICRO-MULCH SYSTEM	

### OUT-FRONT RIDING ACCESSORIES AND OPTIONS

CUSTOM RIDE SEAT SUSPENSION SYSTEM	SNOW BLADE
DUAL-TAIL WHEEL	SNOWBLOWER
FLOOR PAN EXTENDER	SUN SHADE
HITCH KIT	TRASH CONTAINER
LIGHT KIT	ULTRA VAC COLLECTION SYSTEM
MICRO-MULCH SYSTEM	ULTRA VAC QUICK DISPOSAL SYSTEM
ROLL OVER PROTECTION SYSTEM (ROPS)	WEATHER CAB

### WALK-BEHIND ACCESSORIES AND OPTIONS

GRASS CATCHER	TURF STRIPER
MICRO-MULCH SYSTEM	STANDON

\*Some accessories and options not available for some models.

Place Model No. and Serial No.  
Label Here (Included in the Literature  
Pack) or Fill in Below

Model No. \_\_\_\_\_

Serial No. \_\_\_\_\_

Date Purchased \_\_\_\_\_

Engine Model No. and Spec. No. \_\_\_\_\_

Engine Serial No. (E/No) \_\_\_\_\_

© 2015 Exmark Mfg. Co., Inc.  
Industrial Park Box 808  
Beatrice, NE 68310  
All Rights Reserved

Part No. 4502-204 Rev. A  
(402) 223-6300  
Fax (402) 223-5489  
Printed in the USA.

