



MODEL NO. 30137 - 390001 &amp; UP

OPERATOR'S  
MANUAL

## 37" RECYCLER® CUTTING DECK

Proline Mid Size Mowers



To assure maximum safety, optimum performance, and to gain knowledge of the product, it is essential that you or any other operator of the machine read and understand the contents of this manual before the engine is ever started. Pay particular attention to the SAFETY INSTRUCTIONS highlighted by this symbol —



The safety alert symbol means CAUTION, WARNING or DANGER — personal safety instruction. Failure to comply with the instruction may result in personal injury.



# FOREWORD

The 37" Recycler® Cutting Deck has advanced concepts in engineering, design and safety; and if maintained properly, will give excellent service.

Since this is a high-quality product, Toro is concerned about the future use of the machine and safety of the user. Therefore, read this manual to familiarize yourself with proper set-up, operation and maintenance instructions. The major sections of the manual are:

1. Safety Instructions
2. Set-up Instructions
3. Before Operating
4. Operation
5. Maintenance

Certain information in this manual is emphasized. DANGER, WARNING and CAUTION identify personal safety related information. IMPORTANT identifies mechanical information demanding special attention. Be sure to read this directive because it deals with the possibility of damaging a part or parts of the machine. NOTE identifies general information worthy of special attention.

## TABLE OF CONTENTS

|   | Page |  | Page       |
|---|------|--|------------|
| SAFETY INSTRUCTIONS .....                   | 2-3  | Grease Bearings and Bushings .....               | 9          |
| SAFETY AND INSTRUCTION DECALS .....         | 4    | MAINTENANCE .....                                | 9-13       |
| SPECIFICATIONS .....                        | 4    | Trouble Shooting .....                           | 9          |
| LOOSE PARTS .....                           | 5    | Servicing Bushings in Castor Arms .....          | 10         |
| SET-UP INSTRUCTIONS .....                   | 5-7  | Servicing Castor Wheel and Bearings .....        | 10         |
| Install Castor Wheels .....                 | 5    | Checking for Bent Blade .....                    | 11         |
| Mount Carrier Frame to Traction Frame ..... | 5    | Removing Cutter Blades .....                     | 11         |
| Install Drive Belt .....                    | 6    | Checking Sail and Sharpening Cutter Blades ..... | 11         |
| BEFORE OPERATING .....                      | 7    | Correcting Cutting Unit Mismatch .....           | 12         |
| Adjusting Height-of-Cut .....               | 7    | Replacing Drive Belt .....                       | 13         |
| OPERATING INSTRUCTIONS .....                | 7-8  | Replacing Spindle Pulley .....                   | 13         |
| Operating Tips .....                        | 7    | IDENTIFICATION AND ORDERING .....                | 13         |
| To Side Discharge .....                     | 8    | MAINTENANCE CHART .....                          | 14-15      |
| LUBRICATION MAINTENANCE .....               | 9    | THE TORO PROMISE .....                           | Back Cover |

## SAFETY INSTRUCTIONS

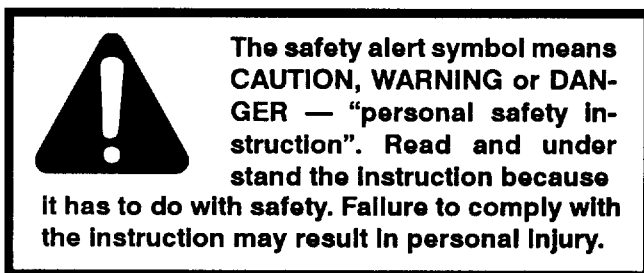

Hazard control and accident prevention are dependent upon the awareness, concern, and proper training of the personnel involved in the operation, transport, maintenance, and storage of the machine. Improper use or maintenance of the machine can result in injury or death. To reduce the potential for injury or death, comply with the following safety instructions.

**WARNING:** Engine exhaust contains carbon monoxide which is an odorless, deadly poison. Carbon monoxide is also known to the State of California to cause birth defects. Do not run engine indoors or in an enclosed area.

### BEFORE OPERATING

1. Read and understand the contents of this Operator's Manual before operating the machine. Become familiar with all controls and know how to stop quickly. A free replacement manual is available by sending complete Model and Serial Number to:

The Toro Company  
8111 Lyndale Avenue South  
Bloomington, Minnesota 55420-1196

2. Never allow children to operate the machine. Do not allow adults to operate machine without proper instruction. Only trained operators who have read this manual should operate this machine.

3. Never operate the machine when under the influence of drugs or alcohol.

4. Before attempting to start engine, shift into neutral and lock parking brake.

5. Remove all debris or other objects that might be picked up and thrown by the cutter blades. Keep all bystanders away from the mowing area.

# SAFETY INSTRUCTIONS

6. Do not operate unless all shields and safety devices are in place. If a shield, safety device or decal is illegible or damaged, repair or replace it before operation is commenced. Also tighten any loose nuts, bolts and screws to assure machine is in safe operating condition.

7. Do not operate machine while wearing sandals, tennis shoes, sneakers or shorts. Also, do not wear loose fitting clothing which could get caught in moving parts. Always wear long pants and substantial shoes. Wearing safety glasses, safety shoes and a helmet is advisable and required by some local ordinances and insurance regulations.

8. Fill fuel tank with gasoline before starting the engine. Avoid spilling gasoline. Since gasoline is flammable, handle it carefully.

- A. Use an approved gasoline container.
- B. Do not fill tank while engine is hot or running.
- C. Do not smoke while handling gasoline.
- D. Fill fuel tank outdoors and up to about one inch (25 mm) from top of the tank, not the filler neck.
- E. Wipe up any spilled gasoline.

## WHILE OPERATING

9. Start engine when parking brake is set (if equipped with brake), blade is disengaged, and transmission is in neutral.

10. Do not run the engine in a confined area without adequate ventilation. Exhaust fumes are hazardous and could possibly be deadly.

11. Using the machine demands attention, and to prevent loss of control:

- A. Mow only in daylight or when there is good artificial light.
- B. Watch for holes or other hidden hazards.
- C. Do not drive close to a sand trap, ditch, creek or other hazard.
- D. Reduce speed when making sharp turns and when turning on hillsides.

12. Do not operate machine unless discharge chute cover, grass deflector or the entire grass catcher is installed. This product is designed to drive objects into the ground where they lose energy quickly in grassy areas. However, don't take an injury risk!! When a person or pet appears unexpectedly in or near the mowing area, STOP MOWING. Careless operation, combined with terrain angles, ricochets, or improperly positioned guards, can lead to thrown object injuries. Do not resume mowing until area is cleared. If the cutting unit discharge area ever plugs, shut engine off and wait for all parts to stop moving before removing the obstruction.

13. Never raise the cutting unit while the blades are rotating.

14. If the cutting blades strike a solid object or the machine vibrates abnormally, shut the engine off. Remove spark plug wire from spark plug to prevent possibility of accidental starting. Check cutting unit and traction unit for damage and malfunctioning parts. Repair any damage before restarting the engine and operating the cutting unit. Be sure blades are in good condition and blade bolts are tight.

15. Cut grass slopes carefully. Do not start, stop, or turn suddenly.

16. Do not touch engine or muffler while engine is running or soon after it is stopped. These areas could be hot enough to cause a burn.

7. To stop engine, shift to Neutral, move throttle to SLOW and turn ignition key to OFF. Wait for all parts to stop moving before leaving the operating position behind handle.

17. Before leaving the operator's position — behind handle or leaving mower unattended, shift transmission into NEUTRAL, apply parking brake (if so equipped), move deck engagement switch to OFF or release control bail and shut OFF engine.

## MAINTENANCE

18. Disconnect spark plug wire from spark plug and close fuel shut off valve to prevent accidental starting of the engine when servicing, adjusting or storing the machine.

19. If traction unit and mower must be tipped to perform maintenance or an adjustment, drain gasoline from fuel tank and oil from crankcase.

20. When driving unit forward, always use upper "Forward" traction drive handle. When backing up, always use lower "Reverse" traction drive handle. (If equipped with upper and lower traction drive handles).

21. To reduce potential fire hazard, keep the engine free of excessive grease, grass, leaves and accumulations of dirt.

22. Be sure machine is in safe operating condition by keeping nuts, bolts and screws tight. Check the blade mounting bolts and nuts frequently to be sure they are tightened to specification.

23. If the engine must be running to perform a maintenance adjustment, keep hands, feet, clothing and other parts of the body away from the cutting unit blades and other moving parts.

24. Do not overspeed the engine by changing governor settings. To be sure of safety and accuracy, have an Authorized TORO Proline Service Dealer check maximum engine speed with a tachometer.

25. Engine must be shut off before checking oil or adding oil to the crankcase.

# SAFETY INSTRUCTIONS

26. Allow engine to cool before storing mower in any enclosure such as a garage or storage shed. Make sure the mower fuel tank is empty if machine is to be stored in excess of 30 days. Do not store mower near any open flame or where gasoline fumes may be ignited by a spark. Always store gasoline in a safety-approved, red metal container.

27. Perform only those maintenance instructions described in this manual. If major repairs are ever needed

or assistance is desired, contact an Authorized Toro Proline Service Dealer. To ensure optimum performance and safety, always purchase genuine TORO replacement parts and accessories to keep the Toro all TORO. NEVER USE "WILL-FIT" REPLACEMENT PARTS AND ACCESSORIES MADE BY OTHER MANUFACTURERS. Look for the TORO logo to assure genuineness. Using unapproved replacement parts and accessories could void the warranty of The Toro Company.

## SAFETY AND INSTRUCTION DECALS

The following decals are installed on the machine. If any become damaged or illegible, replace it. The decal part number is listed below and in your parts catalog. Replacements can be ordered from your Authorized Toro Distributor.



ON L.H. DECK SUPPORT  
(Part No. 43-8480)



ON DISCHARGE COVER  
(Part No. 82-7490)



ON LEFT SIDE OF CUTTING DECK  
(Part No. 54-9220)



ON TOP OF CUTTING DECK  
(Part No. 66-1340)

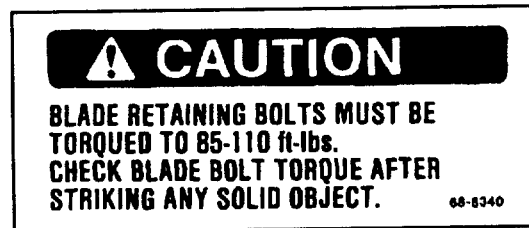

ON TOP OF CUTTING DECK  
(Part No. 68-8340)

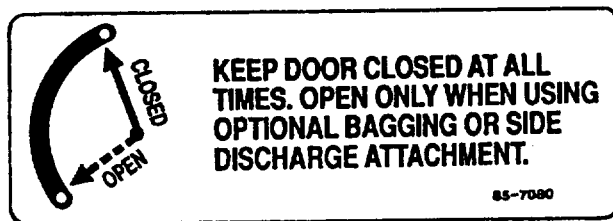

ON TOP OF CUTTING DECK  
(Part No. 85-7080)

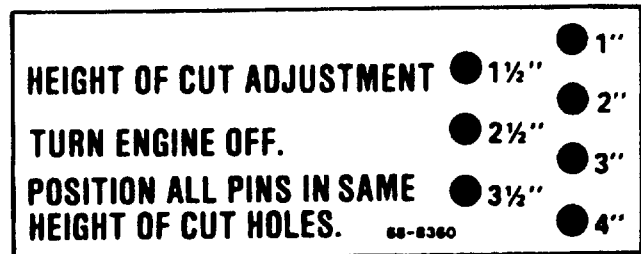

ON BOTH SIDES OF  
CARRIER FRAME  
(Part No. 68-8360, Left Side)  
(Part No. 74-0940, Right Side)



ABOVE DISCHARGE OPENING  
(Part No. 68-3650)



UNDER BELT COVER  
(Part No. 67-5360)

# SPECIFICATIONS

## CUTTING UNIT

Width of Cut: 37 in.

Height-of-Cut: Adjustable from 1" to 4" in 1/2" increments.

**Cutter Blades:** Two heat treated, stamped steel blades each .1345" (10 gage) thick. 17" and 21" long.

**Pneumatic Wheels:** 8 in. dia. with greaseable roller bearings. Inflation 15-35 P.S.I..

Specifications and design subject to change without notice.

## LOOSE PARTS

**NOTE:** Use this chart as a checklist to assure all parts have been received. Without these parts, total set-up cannot be completed.

| Description  | Qty.                       | Use  |
|--|----------------------------|--|
| Angle Bracket - Right<br>Angle Bracket - Left<br>Flange Screws 1/2 - 13 x 1" lg.<br>Flange Locknuts 1/2 - 13               | 1<br>1<br>6<br>6           | Mount Angle Brackets to Traction Frame.                      |
| Carrier Frame<br>Capscrews 3/8 16 x 1-3/4" lg.<br>Locknuts 3/8 - 16<br>Capscrews 3/8 16 x 7/8" lg.<br>Lockwashers<br>Shims | 1<br>4<br>4<br>4<br>4<br>2 | Mount Carrier Frame to Angle Brackets.                       |
| Castor Wheel Assembly<br>Thrust Washer<br>Klip Ring  | 2<br>8<br>2                | Mount Castor Wheels to Carrier Frame.                        |
| Adjusting Shaft<br>Jam Nuts<br>Washer<br>Spring<br>Bushing   | 2<br>4<br>2<br>2<br>2      | Mount Adjusting Shafts.                                      |
| Discharge Chute Assembly   | 1                          | Use to Side Discharge.                                       |
| Operator's Manual<br>Parts Catalog<br>Registration Card  | 1<br>1<br>1                | Read Before Operating Machine<br>Fill Out And Return To Toro |

## SET-UP INSTRUCTIONS

### INSTALL CASTOR WHEELS

1. Place two thrust washers on each castor wheel shaft (Fig. 1).

2. Insert shafts into carrier frame. Install two more thrust washers and secure with Klip rings (Fig. 1).

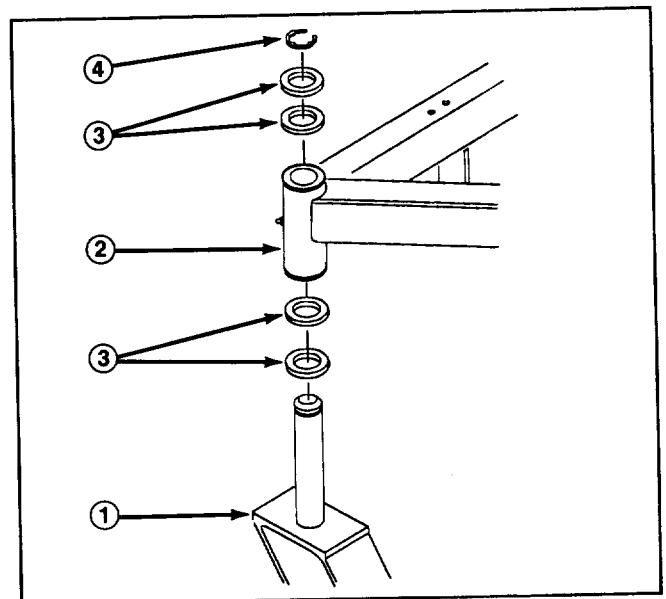

Figure 1

- |                          |                   |
|--------------------------|-------------------|
| 1. Castor wheel assembly | 3. Thrust washers |
| 2. Frame                 | 4. Klip ring      |

# SET-UP INSTRUCTIONS

## MOUNT CARRIER FRAME TO TRACTION FRAME

1. Align left and right angle bracket mounting holes with appropriate mounting holes in traction frame. Secure each bracket to frame with (3) 1/2 - 13 x 1" lg. flange screws and 1/2 - 13 flange locknuts (Fig. 2). Mount bottom flange screws with locknuts to the outside. Torque fasteners to 60-80 ft.-lb.

**IMPORTANT:** When mounting angle brackets to traction frame on Hydraulic driven traction units, use 1/2 - 13 x 1-1/4" lg. flange screws supplied with traction units.

2. Align carrier frame mounting holes with mounting holes in angle brackets, while positioning shim between top of angle bracket and carrier frame, and aligning mounting holes (Fig.2).

3. Secure each side with (2) 3/8 - 16 x 1-3/4" lg. capscrews and 3/8 - 16 locknuts. Locknuts must be positioned outside carrier frame.

4. Secure top of each carrier frame and shim to angle brackets with (2) 3/8 - 16 x 7/8" lg. capscrews and lockwashers. Torque fasteners to 240-320 in.-lb.

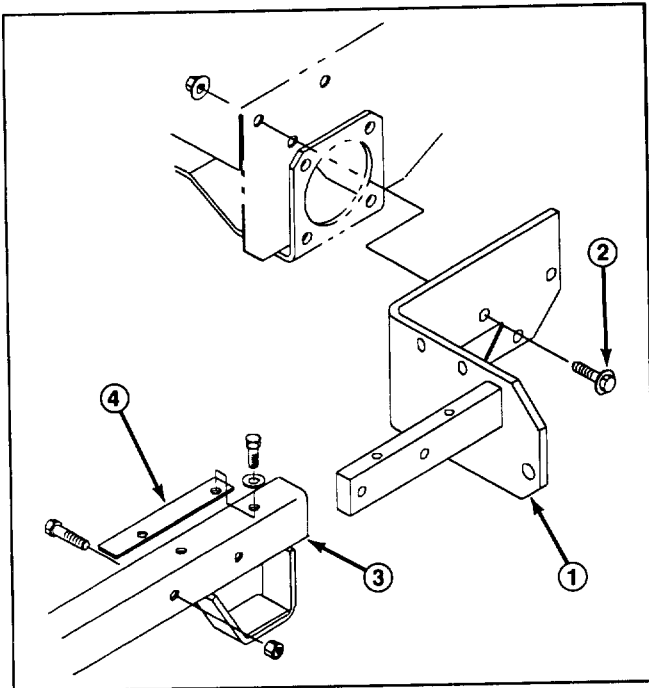

Figure 2

- 1. Angle bracket
- 2. Flange screws and locknuts
- 3. Carrier frame
- 4. Shim

## INSTALL DRIVE BELT

**Note:** To ease the installation of drive belt, belt cover may be removed.

1. Route belt around deck drive pulley and engine clutch pulley (Fig. 3)

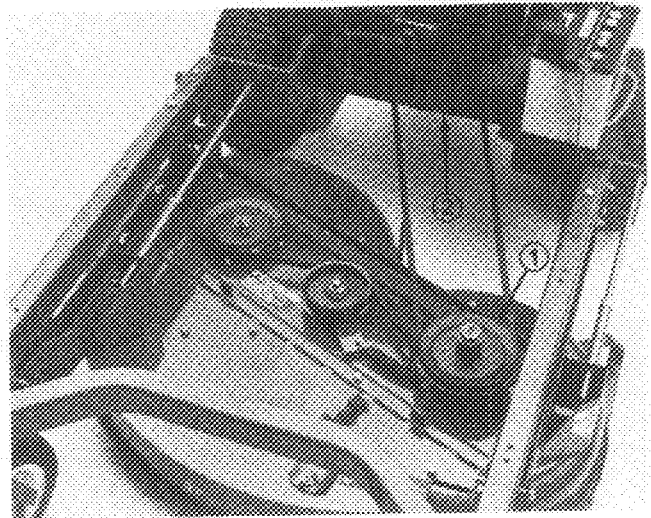

Figure 3

- 1. Drive pulley
- 2. Clutch pulley

2. Thread (2) jam nuts onto each adjusting shaft (approximately 7 inches) (Fig. 4).

3. Slide a washer, spring and bushing onto each adjusting shaft. Bushing to be positioned so flange end is against spring (Fig. 4).

4. Insert spring end of each adjusting shaft into hole in deck mounting bracket and other end of shaft into hole in carrier frame mounting tab. Small end of bushing to fit into hole in deck bracket (Fig. 4).

5. To tension belt, tighten front jam nut on each adjusting shaft until springs are compressed to a length of 5", measured between washer and bushing (Fig. 4). Secure rear jam nuts. Back side of belt to be toward belt guide.

6. Reinstall cover if previously removed.

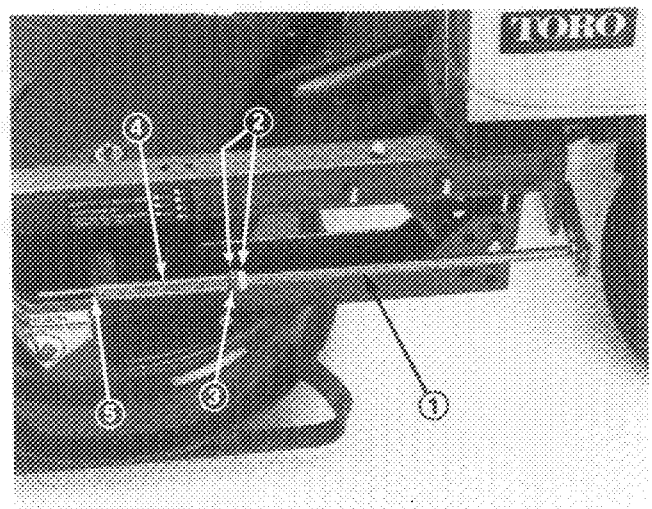

Figure 4

- 1. Adjusting shaft
- 2. Jam nuts
- 3. Washer
- 4. Spring
- 5. Bushing

# BEFORE OPERATING

## ADJUSTING HEIGHT-OF-CUT

The height-of-cut is adjustable from 1 to 4 inches in 1/2 inch increments by relocating four clevis pins in different hole locations in brackets at each corner of cutting unit.

**Note:** All four pins should be in identical hole locations to prevent any operating and cutting difficulties.

**Note:** If cutting unit is to be used in the 1 in. or 1-1/2 in. height-of-cut setting, front rollers must be repositioned in the top bracket holes.

1. Remove cotter pin from roller shaft.
2. Slide shaft out of lower bracket holes, align rollers with top holes and reinstall shaft.

**Note:** Make sure L-shaped pin is inserted into roller shaft and hole in roller bracket.

3. Install cotter pin to secure assembly.

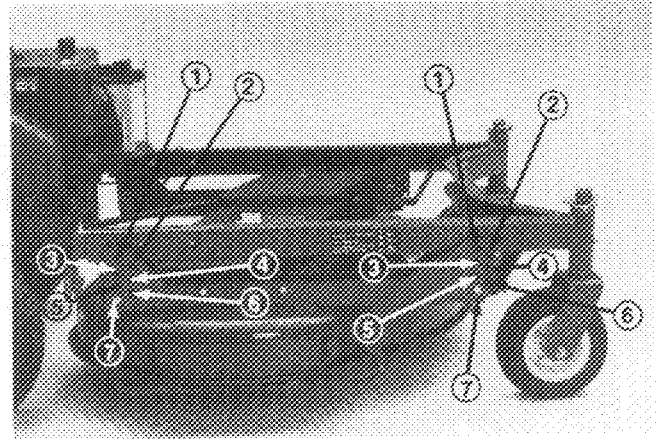

**Figure 5**

1. 1 in.
2. 1-1/2 in.
3. 2 in.

4. 2-1/2 in.
5. 3 in.

6. 3-1/2 in.
7. 4 in.

# OPERATING INSTRUCTIONS

## OPERATING TIPS

1. **MOW WHEN GRASS IS DRY**—Mow either in the late morning to avoid the dew, which causes grass clumping or in late afternoon to avoid the damage that can be caused by direct sunlight on the sensitive, freshly mowed grass.
2. **SELECT THE PROPER HEIGHT-OF-CUT SETTING TO SUIT CONDITIONS**— Remove approximately one inch or no more than 1/3 of the grass blade when cutting. In exceptionally lush and dense grass you may have to raise your height-of-cut setting another notch or convert to side discharge or bagging options.
3. **MOWING IN EXTREME CONDITIONS**—Air is required to cut and recut grass clippings in mower housing, so do not set height-of-cut too low or totally surround housing by uncut grass. Always try to have one side of the mower housing free from uncut grass, allowing air to be drawn into housing. When making an initial cut thru center of uncut area, operate machine slower and back up if mower starts to clog.
4. **MOW AT PROPER INTERVALS**—Under most normal conditions you'll need to mow approximately every 4-5 days. But remember, grass grows at different rates at different times. This means that in order to maintain the same height-of-cut, which is a good practice, you'll need to cut more frequently in early

spring; as the grass growth rate slows in mid summer, cut only every 8-10 days. If you are unable to mow for an extended period due to weather conditions or other reasons, convert to side discharge or bagging options. or mow first with the height-of-cut at a high level; then mow again 2-3 days later with a lower height setting.

5. **ALWAYS MOW WITH SHARP BLADES** — A sharp blade cuts cleanly and without tearing or shredding the grass blades like a dull blade. Tearing and shredding causes the grass to turn brown at the edges which impairs growth and increases susceptibility to diseases.
6. **STOPPING** —If forward motion has to be stopped while cutting, a clump of grass clippings may be deposited on lawn. Follow this procedure for stopping while cutting:
  - A. With deck engaged, move onto a previously cut area.
  - B. Raise deck slightly, while driving forward.
  - C. Shift to neutral, move throttle control lever to SLOW position, move deck engagement switch to OFF or release control bail and rotate ignition key to OFF.
7. **AFTER OPERATING** — To assure optimum performance, clean underside of mower housing, especially around inserts (kickers) after each use. If residue is allowed to build up in mower housing and on inserts, cutting performance will decrease.

# OPERATING INSTRUCTIONS

## TO SIDE DISCHARGE

1. Remove (2) capscrews, lockwashers and wing nuts securing discharge cover to deck channel. Remove cover (Fig. 6).

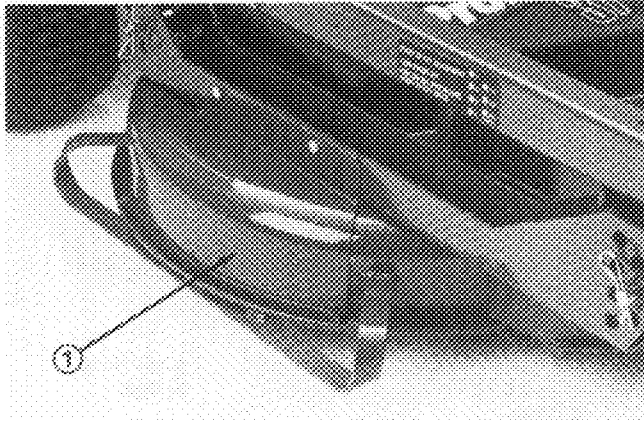

**Figure 6**  
1. Discharge Cover

3. Secure discharge chute (Fig. 7) to deck channel with (2) capscrews, lockwashers and wing nuts previously securing discharge cover to deck channel.



**Figure 7**  
1. Discharge chute

4. Loosen wing nut securing slot cover to top of deck (Fig. 8). Lift cover bump out of slot, rotate cover 180°, pull cover outward to move deck door into the discharge position. Insert cover tung into slot and tighten wing nut.

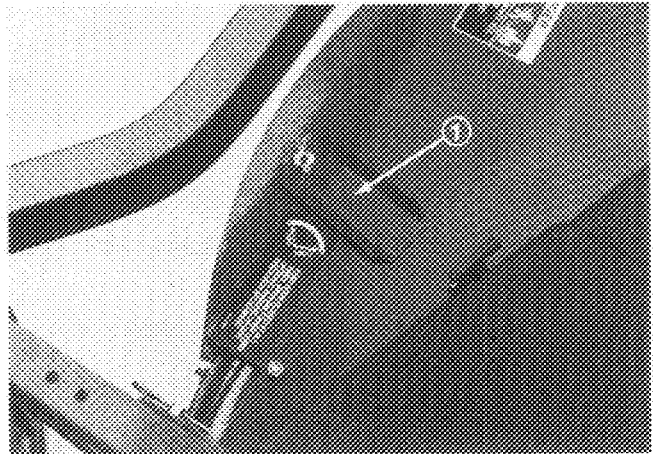

**Figure 8**  
1. Slot cover



### CAUTION

Keep door closed at all times. Open only when using bagging or side discharge attachment.



### DANGER

Do not operate mower without the grass deflector, discharge chute cover or entire grass catcher in place. Make sure deflector is in the lowest possible position.

# LUBRICATION MAINTENANCE

## GREASE BEARINGS AND BUSHINGS

The cutting unit must be lubricated regularly. If machine is operated under normal conditions, lubricate castor bearings and bushings with No. 2 general purpose lithium base grease or molybdenum base grease, after every 8 hours of operation or daily, whichever comes first. All other bearings and bushings must be lubricated after every 50 hours of operation.

1. The cutting unit has bearings and bushings that must be lubricated, and these lubrication points are: castor spindle bushings, castor wheel bearings, idler pivot and blade spindle bearings (Fig. 9)

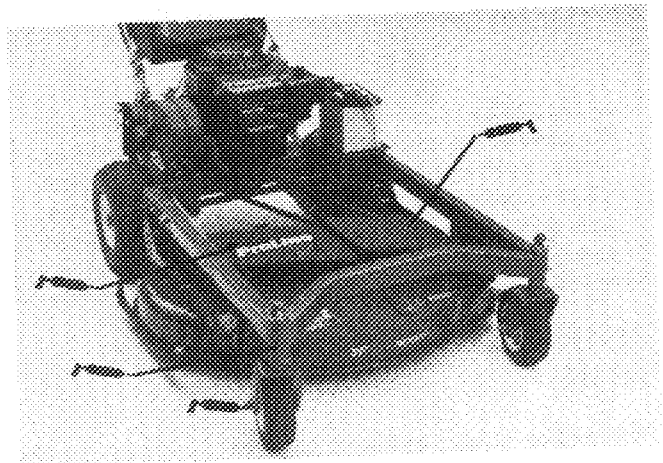
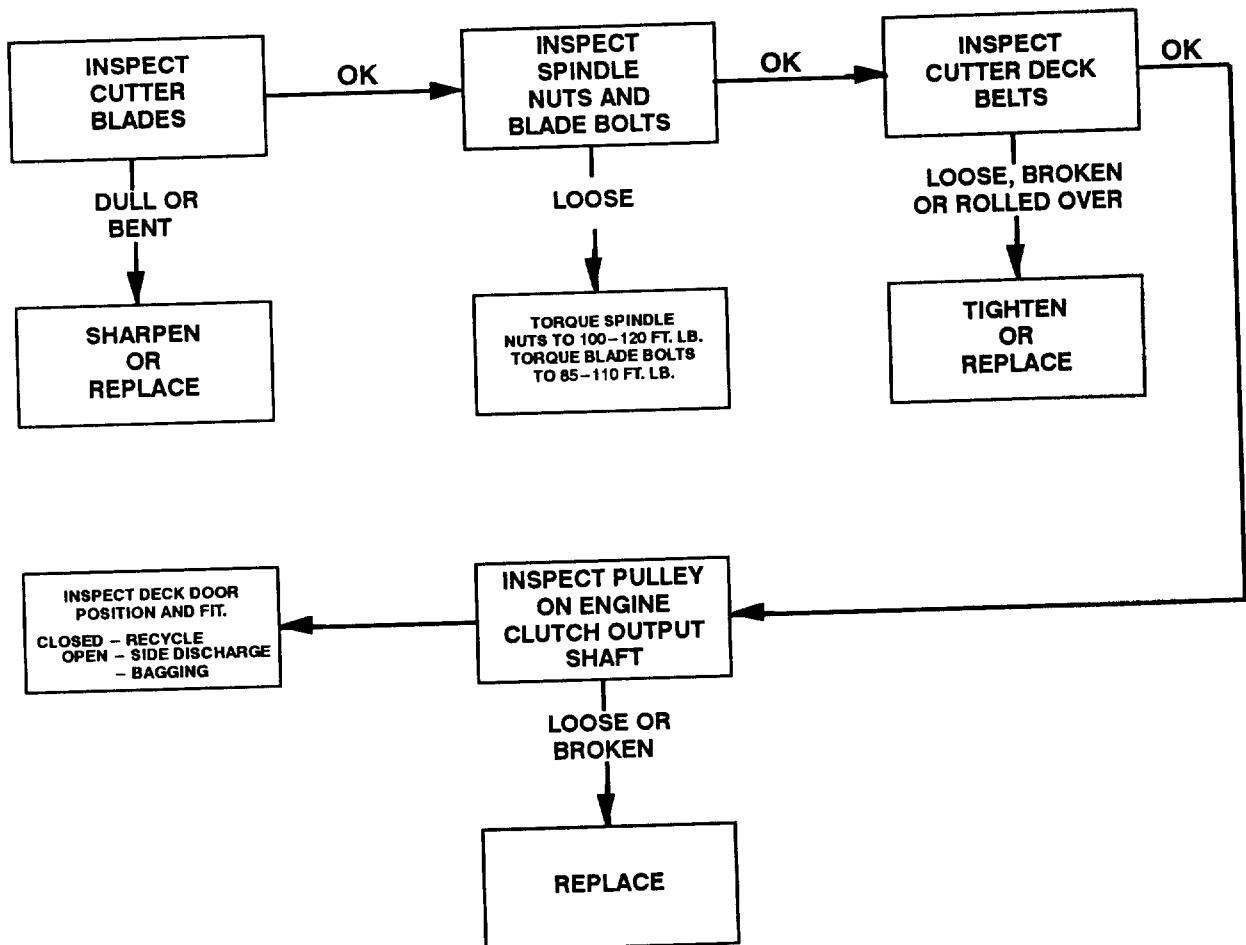

Figure 9

## CUTTING UNIT MAINTENANCE TROUBLESHOOTING

### UNIT WILL NOT CUT OR CUTS POORLY



# CUTTING UNIT MAINTENANCE



## CAUTION

To prevent accidental starting of the engine, while performing maintenance, shut engine off and remove key from ignition switch. Also, pull wire off spark plug. Make sure wire does not contact plug accidentally.

## SERVICING BUSHINGS IN CASTOR ARMS

The castor arms have bushings pressed into the top and bottom of the tube and after many hours of operation, the bushings will wear. To check the bushings, move castor fork back and forth and from side to side. If castor spindle is loose inside the bushings, bushings are worn and must be replaced.

1. Raise cutting unit so wheels are off floor and block it so it cannot fall accidentally.
2. Remove Klip ring and thrust washers from top of castor spindle.
3. Pull castor spindle out of mounting tube. Allow thrust washers to remain on bottom of spindle.
4. Insert pin punch into top or bottom of mounting tube and drive bushing out of tube (Fig. 10). Also drive other bushing out of tube. Clean inside of tubes to remove dirt.

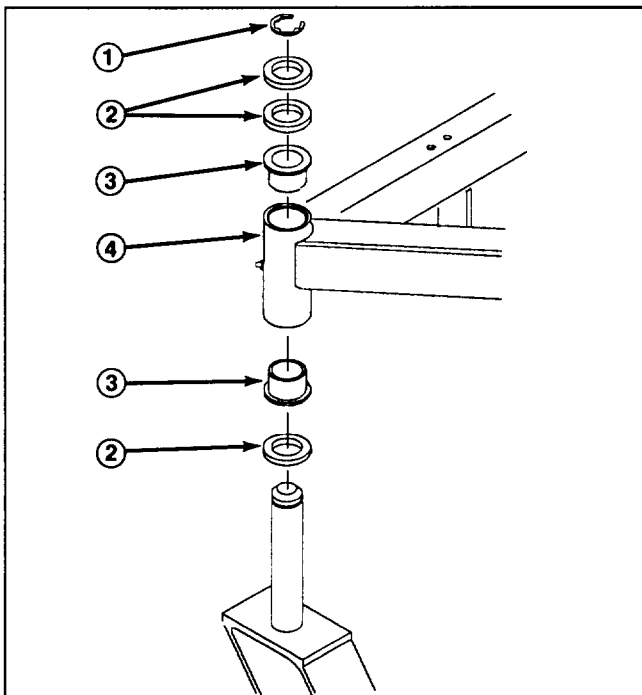

Figure 10

- |                   |                  |
|-------------------|------------------|
| 1. Klip ring      | 3. Bushings      |
| 2. Thrust washers | 4. Mounting tube |

5. Apply grease to inside and outside of new bushings. Using a hammer and flat plate, drive bushings into mounting tube.

6. Inspect castor spindle for wear and replace it if damaged.

7. Push castor spindle through bushings and mounting tube. Slide thrust washers onto spindle. Install klip ring on castor spindle to retain all parts in place.

**IMPORTANT:** When bushings are installed, the inside diameter may collapse slightly, and this may not allow castor spindle to be installed. If castor spindle does not slide through new bushings and mounting tube, ream both bushings to inside diameter of 1.126 inches.

## SERVICING CASTOR WHEEL AND BEARING

The castor wheel rotates on a high-quality roller bearing and is supported by a spanner bushing. Even after many hours of use, provided that the bearing was kept well-lubricated, bearing wear will be minimal. However, failure to keep bearing lubricated will cause rapid wear. A wobbly castor wheel usually indicates a worn bearing.

1. Remove locknut from capscrew holding castor wheel assembly between castor fork (Fig. 11). Grasp castor wheel and slide capscrew out of fork.

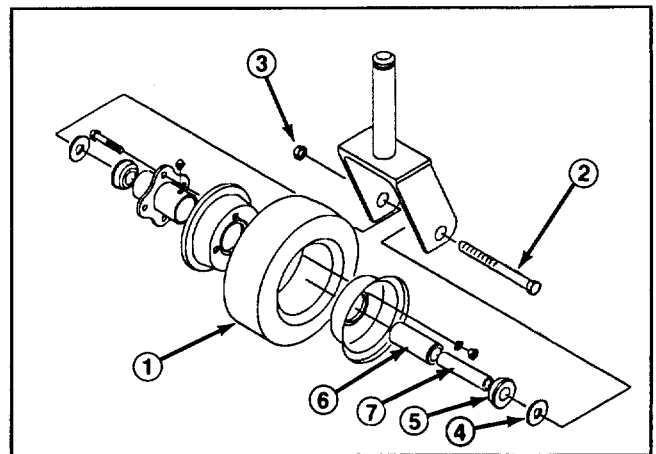

Figure 11

- |                  |                     |
|------------------|---------------------|
| 1. Castor wheel  | 5. Bearing retainer |
| 2. Capscrew      | 6. Roller bearing   |
| 3. Locknut       | 7. Spanner bushing  |
| 4. Thrust washer |                     |

**Note:** Account for the two flat washers (Fig. 11).

2. Tip wheel to the side and allow roller bearing and spanner bushing to fall out (Fig. 11).

3. Inspect bearing, spanner bushing and inside diameter of wheel for wear. Replace defective parts.

4. To reassemble parts, slide spanner bushing through roller bearing. Pack bearing with no. 2 grease; then insert bearing w/spanner bushing into wheel.

# CUTTING UNIT MAINTENANCE

5. Slide bearing retainer onto spanner bushing and mount castor wheel assembly between the fork with the capscrew and locknut. Tighten capscrew and locknut until spanner bushing bottoms against inside of castor fork.

6. Pump more grease through grease fitting on wheel (Fig. 11) until bearing is greased thoroughly.

## CHECKING FOR BENT BLADE

1. Rotate blade until the ends face forward and backward (Fig. 12). Measure from inside of cutting unit to cutting edge at front of blade (Fig. 12), and remember this dimension.

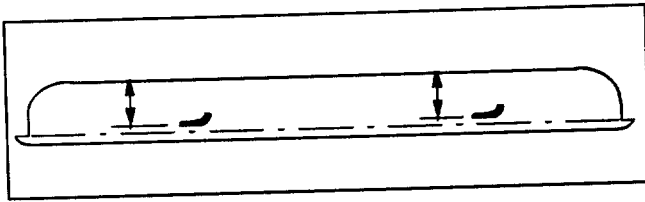

Figure 12

2. Rotate opposite end of blade forward. Measure between the cutting unit and cutting edge of blade at the same position as in step 2. The difference between dimensions obtained in steps 1 and 2 must not exceed 1/8 of an inch. If dimension exceeds 1/8 of an inch, replace the blade because it is bent: refer to Removing Cutter Blades, page 11.

## REMOVING CUTTER BLADES

The blade must be replaced if a solid object is hit, the blade is out-of-balance or if the blade is bent. Always use genuine TORO replacement blades to be sure of safety and optimum performance. Never use replacement blades made by other manufacturers because they could be dangerous.

1. Grasp end of blade using a rag or thickly padded glove. Remove blade bolt, lockwasher and blade from spindle shaft.

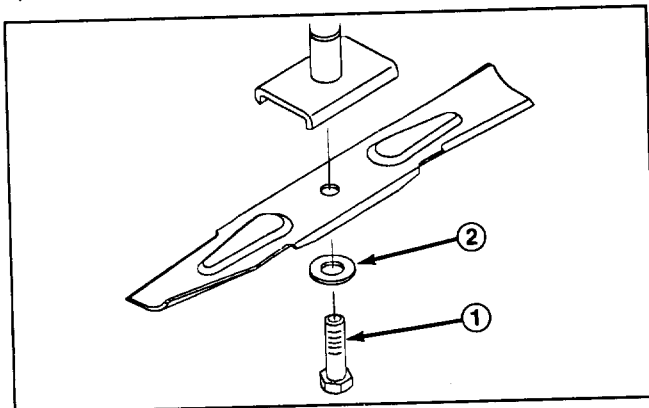

Figure 13

1. Blade bolt 2. Lockwasher

2. Install blade—sail facing toward cutting unit with blade bolt and lock washer. Tighten to 85–110 ft–lb.



## WARNING

Do not try to straighten a blade that is bent, and never weld a broken or cracked blade. Always use a new blade to assure safety.

## CHECKING SAIL AND SHARPENING CUTTER BLADE

Two areas must be considered when checking and servicing the cutter blade: one area is the sail, the other is the cutting edge. Both cutting edges and the sail, which is the turned up metal opposite the cutting edge, contribute to a good quality-of-cut. The sail is important because it pulls grass up straight, thereby producing an even cut. However, the sail will gradually wear down during operation, and this condition is normal. As the sail wears down, the quality-of-cut will degrade somewhat, although the cutting edges are sharp. The cutting edge of the blade must be sharp so the grass is cut rather than torn. A dull cutting edge is evident when tips of the grass appear brown and shredded. Sharpen the cutting edges to correct this condition.

1. Examine cutting ends of the blade carefully, especially where the flat and curved parts of the blade meet (Fig. 14–A). Since sand and abrasive material can wear away the metal that connects the flat and curved parts of the blade, check the blade before using the mower. If wear is noticed (Fig. 14–B), replace the blade.

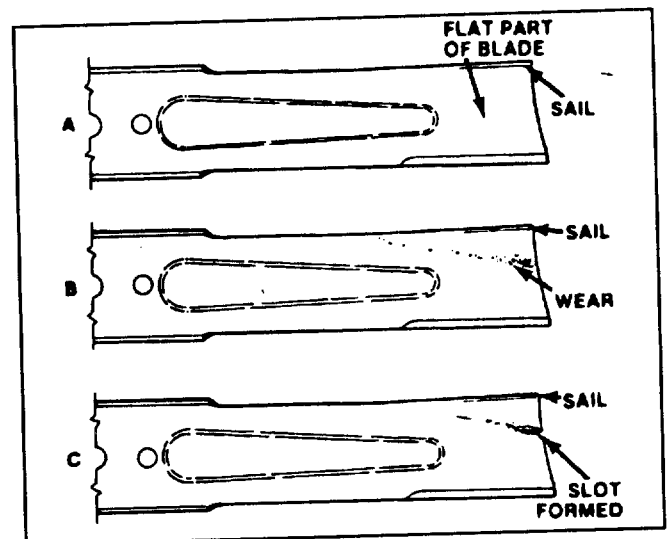



Figure 14

2. Inspect cutting edges of all blades. Sharpen the cutting edges if they are dull or nicked. Sharpen only the top of the cutting edge and maintain the original cutting angle to make sure of sharpness (Fig. 15). The blade will remain balanced if same amount of metal is removed from both cutting edges.

# CUTTING UNIT MAINTENANCE

 **DANGER**

If blade is allowed to wear, a slot will form between the sail and flat part of the blade (Fig. 14-C). Eventually a piece of the blade may break off and be thrown from under the housing, possibly resulting in serious injury to yourself or bystander.

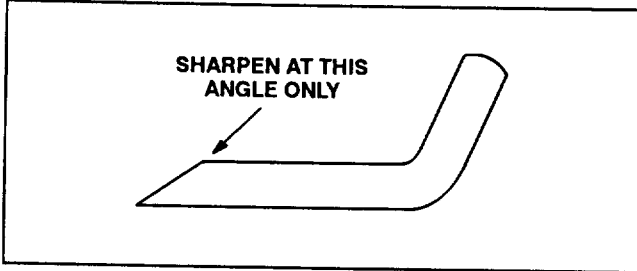

Figure 15

**Note:** Remove the blades and sharpen them on a grinder: refer to Removing Cutter Blades, steps 1 and 2, page 11. After sharpening the cutting edges, re-install blade with blade bolt and lockwasher. Blade sails must be on top of blade. Tighten blade bolt to 85–110 ft-lb.

## CORRECTING CUTTING UNIT MISMATCH

If one cutter blade cuts lower than the others, correct as follows:

1. Check to make sure all four height-of-cut pins are resting properly on frame cushions.
2. Raise height-of-cut to the 3-1/2" or 4 in. position: refer to Adjusting Height-Of-Cut, page 7.
3. Rotate blades so tips line up with one another. Tips of the adjacent blades must be within 1/8 in. of each other. If tips are not within 1/8 in. of each other, proceed to step 7 and add shims between spindle housing and bottom of cutting unit.
4. Position both blades in the "A" position (Fig. 16) and measure from level surface to the bottom of the tip end of each blade (Fig. 17).

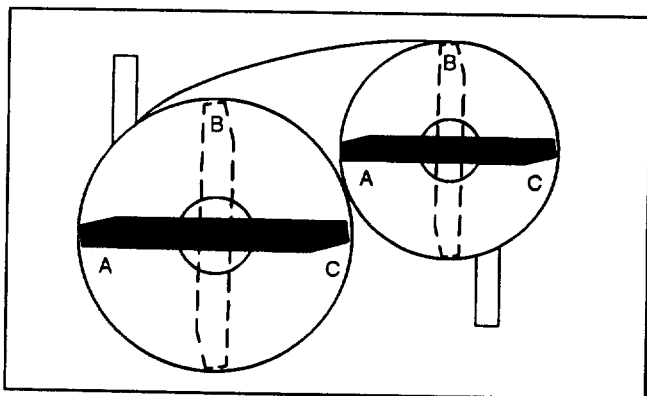

Figure 16

5. Note measurement attained at "A", rotate blades to "B" position (Fig. 16), measure distance of all blades to level surface and note dimensions (Fig. 17).

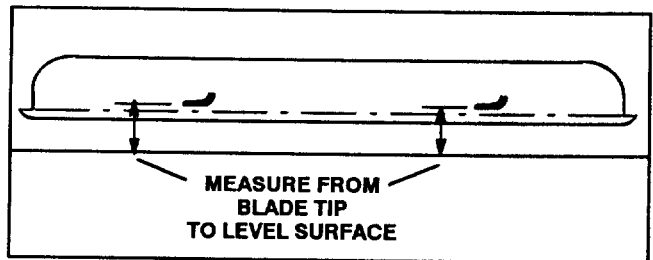

Figure 17

6. Rotate blades to "C" position, measure and note distance measured (Fig. 16).

7. Compare measurements at various positions. all dimensions must be equal within 1/4 in. from one another. The difference between dimensions must not exceed 1/4 in. . If difference exceeds 1/4 in., proceed to step 8 and 9 and add shims between spindle housing and bottom of cutting unit.

8. Remove capscrews, flatwashers, lockwashers and nuts from spindle in the area where shims must be added. To raise or lower the blade, add a shim, Part No. 3256-24, between spindle housing and bottom of cutting unit. Continue checking alignment of blades and adding shims until tips of blades are within the required dimension.

9. Equalize side-to-side measurements as follows:

**A.** Cutting units usually operated at 1 to 2 in. height-of-cut should have the low side of the cutting unit raised. Remove the Klip ring securing castor wheel on low end and remove castor assembly.

**B.** Transfer one thrust washer from top side of castor shaft to lower side, install castor assembly and compare blade height of all blades; refer to items 3 through 7. Continue adding thrust washers if height still does not meet requirements.

**C.** If cutting unit is operated at 2 to 4 in. height-of-cut, lower the high side of cutting unit. Remove Klip ring of castor at high end of unit and remove castor assembly.

**D.** Transfer one thrust washer from lower side of castor shaft to top side, install assembly and compare blade height of all blades; refer to items 3 through 7. Repeat procedure if height still does not meet requirements.

**E.** If height is within specified dimension, install Klip ring, set height-of-cut to proper height and resume operation.

# CUTTING UNIT MAINTENANCE

## REPLACING DRIVE BELT

The blade drive belt, tensioned by the spring loaded idler, is very durable. However, after many hours of use, the belt will show signs of wear. Signs of a worn belt are: squealing when belt is rotating, blades slipping when cutting grass, frayed edges, burn marks and cracks. Replace the belt if any of these conditions are evident.

1. Unhook latches and remove belt cover from top of cutting unit.
2. Loosen jam nuts on each adjusting shaft and remove engine to deck drive belt (Fig. 18).

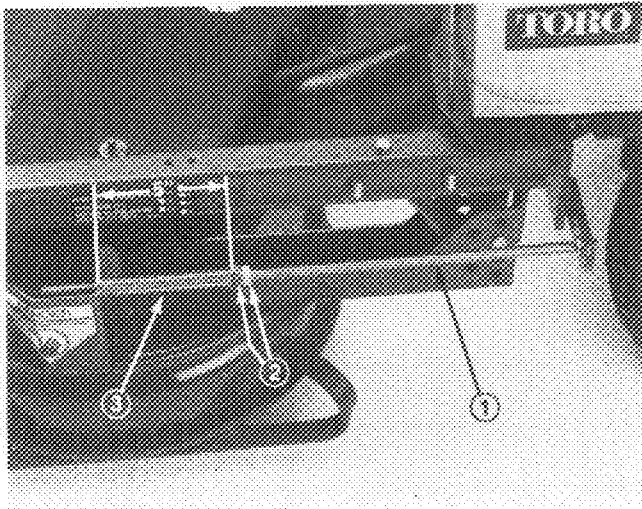

**Figure 18**

1. Adjusting shaft
2. Jam nuts
3. Spring

3. Move idler pulley away from belt, removing belt tension and allowing belt to be removed from pulleys.
4. Install new belt around spindle pulleys and idler pulley (Fig.19).

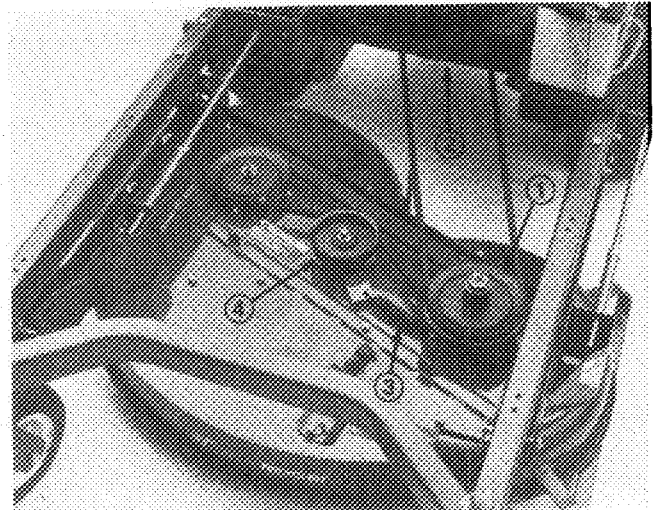

**Figure 19**

1. Drive pulley
2. Clutch pulley
3. Idler spring
4. Idler pulley

5. Install belt to drive and clutch pulley (Fig. 19).
6. Reinstall belt cover.
7. Tighten jam nuts on adjusting shafts until springs are compressed to a length of 5", measured between washer and bushing.

## REPLACING SPINDLE PULLEY

1. Remove cover from cutting unit.
  2. Remove drive belt; refer to Replacing Drive Belt, page 12.
- Note:** Hold spindle assembly together or block it up from the bottom of cutting unit when removing nut from pulley, as spindle shaft may slide thru spindle housing.
3. Remove nut retaining pulley on spindle shaft. Pull pulley off shaft.
  4. Install new pulley on spindle shaft with locknut. Tighten nut to 100–120 ft–lb.
  5. Reinstall belts and cover.

# IDENTIFICATION AND ORDERING

## MODEL AND SERIAL NUMBERS

The cutting deck has two identification numbers: a model number and a serial number. The two numbers are stamped into a plate that is riveted to right side of carrier frame. In any correspondence concerning the mower, supply the model and serial numbers to assure that correct information and replacement parts are obtained.

To order replacement parts from an authorized TORO Distributor, supply the following information:

1. Model and serial numbers of the machine.
2. Part number, description and quantity of parts desired.

**Note:** Do not order by reference number if a parts catalog is being used; use the part number.







ProLine  
Products

## THE TORO TOTAL COVERAGE GUARANTEE

A One Year Limited Warranty  
(A Full Two-Year Warranty for Residential Use)

### What Is Covered By This Express Warranty?

The Toro Company promises to repair any TORO ProLine product used for commercial, institutional, or rental purposes if defective in materials or workmanship for a period of one year from the date of purchase. The cost of parts and labor are included as well as transportation within a 15 mile radius of a TORO ProLine Service Dealer.

### What Products Are Covered By This Warranty?

ProLine products covered by this warranty include the ProLine 118 and wide area walk behind mowers and their cutting decks and accessories.

### How About Residential Use?

TORO ProLine products used for residential use are covered by a full two-year warranty.

### How Do You Get Warranty Service?

Should you feel your TORO ProLine product contains a defect in materials or workmanship, contact the dealer who sold you the product or any TORO ProLine Service Dealer. The Yellow Pages of your telephone directory is a good reference source; look under TORO Commercial Service Dealers. The Service Dealer will either arrange service at his/her dealership or recommend another authorized Service Dealer who may be more convenient. You may need proof of purchase (copy of registration card, sales receipt, etc.) for warranty validation.

If for any reason you are dissatisfied with a Service Dealer's analysis of the defect in materials or workmanship or if you need a referral to a TORO ProLine Service Dealer, please feel free to contact us at the following address:

Toro Customer Service Department  
8111 Lyndale Avenue South  
Minneapolis, MN 55420  
612-888-8801

### What Must You Do To Keep The Warranty In Effect?

You must maintain your TORO Product by following the maintenance procedures described in the operator's manual. Such routine maintenance, whether performed by a dealer or by you, is at your expense.

### What Does This Warranty Not Cover? and

### How Does Your State Law Relate To This Warranty?

There is no other express warranty except as described above. This express warranty does not cover:

- Cost of regular maintenance service or parts, such as filters, fuel, lubricants, tune-up parts, blade sharpening, brake and clutch adjustments.
- Any product or part which has been altered or misused or required replacement or repair due to normal wear, accidents, or lack of proper maintenance.
- Repairs necessary due to improper fuel, contaminants in the fuel system, or failure to properly prepare the fuel system prior to any period of non-use over three months.
- Pickup and delivery charges for distances beyond a 15 mile radius from a TORO ProLine Service Dealer.

All repairs covered by this warranty must be performed by a TORO Service Dealer using Toro approved replacement parts.

Repair by a TORO Service Dealer is your sole remedy under this warranty.

**The Toro Company is not liable for indirect, incidental or consequential damages in connection with the use of the TORO Products covered by this warranty, including any cost or expense of providing substitute equipment or service during reasonable periods of malfunction or non-use pending completion of repairs under this warranty. Some states do not allow exclusions of incidental or consequential damages, so the above exclusion may not apply to you.**

**This warranty gives you specific legal rights, and you may also have other rights which vary from state to state.**

### COUNTRIES OTHER THAN THE UNITED STATES OR CANADA

Customers who have purchased TORO products exported from the United States or Canada should contact their TORO Distributor (Dealer) to obtain guarantee policies for your country, province, or state. If for any reason you are dissatisfied with your Distributor's service or have difficulty obtaining guarantee information, contact the TORO importer. If all other remedies fail, you may contact us at The Toro Company.